

# EA-PS 800 19" 80 W - 240 W



## 19" 盒式直流电源

19" plug-in DC power supplies as Euro cassette



EA-PS 800-19"

F

U

OTP

- 宽范围输入电压90...264 V，带主动式PFC
- 效率：高达 92%
- 输出功率：58 W 至240 W
- 输出电压：3.3 V 至 24 V
- 输出电流：2.5 A 至 30 A
- 单路，双路和三路输出
- 功率受限，所有输出端可输出全功率
- 所有输出端可分开调节和调整
- 有过温保护 (OT)
- 远程开/关，电源断电提示信号
- 远程感测功能
- 可选项
  - 电源输出端之间功率共享\*
  - 无前面板

### 概要

EA-PS 800 19"系列有单组、两组和三组输出的不同类型产品。结合同步整流二极管和半谐振变换器，使其效率高达92%，是极其高效且稳定可靠的产品。

### 直流输出

本系列有不同型号，可选择3.3 V, 5 V, 12-15 V和24 V输出电压，80 W, 150 W和240 W输出功率的类型。所有输出端，不管是主输出还是辅助输出，都有静态限流和限功率电路，并能单独稳定，实现真正零负载兼容，具有完全的短路保护和超载保护。通过前板可调电位器可在特定范围内调节所有输出电压，以适应敏感性负载，并经LED灯指示出来。内置OVP保护电流可保护连接负载不因直流过压而受损。

- Wide input voltage range 90...264 V with active PFC
- High efficiency up to 92%
- Output power ratings: 58 W up to 240 W
- Output voltages: 3.3 V up to 24 V
- Output currents: 2.5 A up to 30 A
- Single, double or triple output
- Power limited, all outputs for full power
- All outputs separately adjustable and regulated
- Overtemperature protection (OT)
- Remote on/off and power fail signal
- Remote sensing
- Options
  - Power sharing\* between mains outputs
  - Without front plate

### General

The models of series EA-PS 800 19" are available as single, dual or triple output power supplies. By combining the synchronised rectifier and semi-resonant converter principle, an efficiency of up to 92% is achieved, making them highly efficient and extremely reliable.

### DC output

A selection of output voltages between 3.3 V, 5 V, 12-15 V and 24 V at power levels of 80 W, 150 W and 240 W are available. All outputs, main and auxiliary, are provided with a static current limit and a power limit circuit and are stabilised independently, making them truly zero-load compatible, fully short-circuit- and overload-proof. All output voltages can be trimmed within a specific range by potentiometers located in the front panel to accommodate sensitive loads, and are visualised via LEDs. The integrated OVP protects the equipment connected from DC overvoltage damage.

## EA-PS 800 19" 80 W - 240 W

## 输入

主动式功率因数校正与宽范围的输入电压90 V...264 V AC (120...360 V DC)，使本系列在全球范围内都适用，它还可当隔离DC/DC转换器用。

## 远程感测

远程感测输入电路为一H15端子，可直接连到负载的输入端，以补偿市电输出线上的压降，确保给敏感性设备供应稳定又精确的电压。

## 稳定后的直流输出

图1: PS805-150 19"从2.5 A到18 A的负载阶跃图

图2: 主输出的负载阶跃表现出了它能单独稳定，且不影响辅助输出。



图 1 / Figure 1

## Input

A wide input range of 90 V...264 V AC (120 V...360 V DC) with active PFC (power factor correction) makes them suitable for a worldwide usage or as isolated DC/DC converters as well.

## Remote sensing

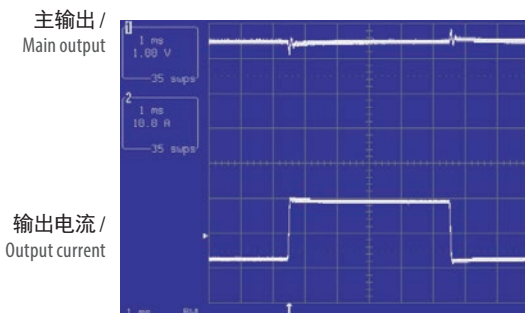
The remote sensing circuit located at the H15 connector can be connected to the input terminals of the load in order to compensate the voltage loss across the main output wires, ensuring a stable and precise voltage to sensitive equipment.

## Stabilised DC output

Figure 1: Load step from 2.5 A to 18 A at PS805-150 19"

Figure 2: The load step on the main output illustrates the separated stabilisation for the main output which does not affect the auxiliary output.



图 2 / Figure 2

## 选项

- ASF: 额外功率共享引脚，仅针对单路输出产品。利用它可以建立冗余电源系统。
- 按照客户需求，可将多个模块并联组合成一整套19"机架式系统，还能组成客户指定的输出版本。

## Options

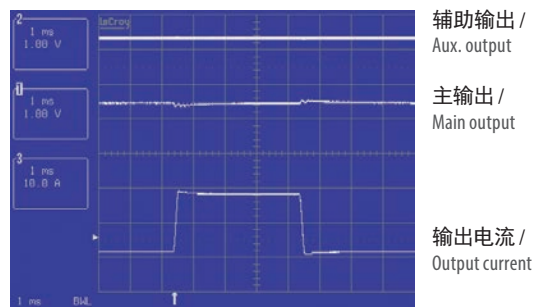
- ASF: additional power sharing pin, only for single output models. It provides the possibility to build up a redundant power system.
- Complete 19" rack systems with parallel redundant modules and custom specific output versions are available upon request.

技术参数	Technical Data	EA-PS 800 19" 80 W	EA-PS 800 19" 150 W	EA-PS 800 19" 240 W
交流输入电压	Input voltage AC	90...264 V, 1ph+N, 45...65 Hz, PF = >0.99		
直流输入电压	Input voltage DC	90...360 V		
效率	Efficiency	高达 / up to 89%	高达 / up to 91%	高达 / up to 92%
输入浪涌电流限制	Input surge current limitation	<23 A by NTC / 通过NTC		
输入尖峰电压抑制	Input voltage spike suppression	通过 / by VDR		
保持时间	Hold-up time	>20 ms		
输出功率	Output power	58 W ... 96 W	87 ... 150 W	108 ... 240 W
感测调整的电压	Voltage regulation with sensing	0.5 V max.		
电源断电信号	Power fail signal	after >5 ms / 5 ms后		
控制输入	Control input	外部开-关 / external on-off		
ASF信号的功率共享	Power share with ASF signal	可选 / optional		
工作温度	Operation temperature	0...70 °C	0...70 °C	0...70 °C
温度 / 功率降额	Temperature / Derating			
- 自然对流式	- with natural convection	>45 °C 2.1 W/°C	>45 °C 4 W/°C	>45 °C 6.4 W/°C
- 强制风冷式 1 m/s	- with forced cooling 1 m/s	>60 °C 4 W/°C	>60 °C 7.5 W/°C	>60 °C 12 W/°C
储存温度	Storage temperature	-40 °C ... +85 °C		
相对湿度	Relative humidity	<90%, n-c.		
安规标准	Safety	EN 60950, IEC 950	EN 60950, IEC 950	EN 60950, IEC 950
EMI辐射	EMI emission	EN 61000-6-3	EN 61000-6-3	EN 61000-6-3
EMI抗干扰度	EMI noise immunity	EN 61000-6-2	EN 61000-6-2	EN 61000-6-2
尺寸 (宽x高x深)	Dimensions (WxHxD)	8TE/HP x 3HE/U x 162 mm	10TE/HP x 3HE/U x 162 mm	12TE/HP x 3HE/U x 162 mm
重量	Weight	640g	780g	930g



## EA-PS 800 19" 80 W - 240 W

## 80 W



技术参数	Technical Data	PS 803-80 Single	PS 805-80 Single	PS 812-80 Single	PS 824-80 Single
直流输出电压	Output voltage DC	3.3 V (3.0...3.6 V)	5 V (4.8...5.5 V)	12 V (11.8...15.2 V)	24 V (23.5...28.5 V)
0...100% I <sub>out</sub> 的负载调整率	Load regulation 0...100% I <sub>out</sub>	<0.05%	<0.05%	<0.05%	<0.05%
100% I <sub>out</sub> 的线性调整率	Line regulation 100% I <sub>out</sub>	<0.05%	<0.05%	<0.05%	<0.05%
LF纹波	Ripple LF	<40 mV <sub>pp</sub>	<40 mV <sub>pp</sub>	<40 mV <sub>pp</sub>	<40 mV <sub>pp</sub>
10-100% 负载调整需时	Regulation time 10-100% load	<0.5 ms	<0.5 ms	<0.5 ms	<0.5 ms
OVP调节范围	OVP adjustment	3.8...4.5 V	6.0...6.7 V	16.5...18.0 V	29.0...33.0 V
输出电流 / 功率	Output current / power	16 A / 58 W	16 A / 80 W	7.5 A / 90 W	4 A / 96 W
输出电流限制	Output current limit	<19 A	<19 A	<8.5 A	<4.8 A
订购编号	Ordering number	08130300	08130301	08130302	08130303

技术参数	Technical Data	PS 805-12-80 Double	PS 805-24-80 Double
直流输出电压	Output voltage DC	5 V (4.8...5.5 V)	12 V (11.8...15.2 V)
0...100% I <sub>out</sub> 的负载调整率	Load regulation 0...100% I <sub>out</sub>	<0.05%	<0.2%
100% I <sub>out</sub> 的线性调整率	Line regulation 100% I <sub>out</sub>	<0.05%	<0.2%
LF纹波	Ripple LF	<40 mV <sub>pp</sub>	<40 mV <sub>pp</sub>
10-100% 负载调整需时	Regulation time 10-100% load	<0.5 ms	<0.5 ms
OVP调节范围	OVP adjustment	6.0...6.7 V	16.5...18.0 V
输出电流 / 功率	Output current / power	16 A / 80 W	2.5 A
输出电流限制	Output current limit	<19 A	<3.0 A
订购编号	Ordering number	08130304	08130305

技术参数	Technical Data	PS 812-12-80 Double	PS 812-24-80 Double
直流输出电压	Output voltage DC	12 V (11.8...15.2 V)	12 V (11.8...15.2 V)
0...100% I <sub>out</sub> 的负载调整率	Load regulation 0...100% I <sub>out</sub>	<0.05%	<0.2%
100% I <sub>out</sub> 的线性调整率	Line regulation 100% I <sub>out</sub>	<0.05%	<0.2%
LF纹波	Ripple LF	<40 mV <sub>pp</sub>	<40 mV <sub>pp</sub>
10-100% 负载调整需时	Regulation time 10-100% load	<0.5 ms	<0.5 ms
OVP调节范围	OVP adjustment	16.5...18.0 V	16.5...18.0 V
输出电流 / 功率	Output current / power	7.5 A / 90 W	2.5 A
输出电流限制	Output current limit	<8.5 A	<3.0 A
订购编号	Ordering number	08130306	08130307

技术参数	Technical Data	PS 805-12-12-80 Triple		
直流输出电压	Output voltage DC	5 V (4.8...5.5 V)	+12 V (11.8...15.2 V)	-12 V (11.8...15.2 V)
0...100% I <sub>out</sub> 的负载调整率	Load regulation 0...100% I <sub>out</sub>	<0.05%	<0.2%	<0.2%
100% I <sub>out</sub> 的线性调整率	Line regulation 100% I <sub>out</sub>	<0.05%	<0.2%	<0.2%
LF纹波	Ripple LF	<40 mV <sub>pp</sub>	<40 mV <sub>pp</sub>	<40 mV <sub>pp</sub>
10-100% 负载调整需时	Regulation time 10-100% load	<0.5 ms	<0.5 ms	<0.5 ms
OVP调节范围	OVP adjustment	6.0...6.7 V	16.5...18.0 V	16.5...18.0 V
输出电流 / 功率	Output current / power	16 A / 80 W	2.5 A	2.5 A
输出电流限制	Output current limit	<19 A	<3.0 A	<3.0 A
订购编号	Ordering number	08130308		

**EA-PS 800 19" 80 W - 240 W****150 W**

技术参数	Technical Data	PS 803-150 Single	PS 805-150 Single	PS 812-150 Single	PS 824-150 Single
直流输出电压	Output voltage DC	3.3 V (3.0...3.6 V)	5 V (4.8...5.5 V)	12 V (11.8...15.2 V)	24 V (23.5...28.5 V)
0...100% I <sub>out</sub> 的负载调整率	Load regulation 0...100% I <sub>out</sub>	<0.05%	<0.05%	<0.05%	<0.05%
100% I <sub>out</sub> 的线性调整率	Line regulation 100% I <sub>out</sub>	<0.05%	<0.05%	<0.05%	<0.05%
LF纹波	Ripple LF	<40 mV <sub>pp</sub>	<40 mV <sub>pp</sub>	<40 mV <sub>pp</sub>	<40 mV <sub>pp</sub>
10-100% 负载调整需时	Regulation time 10-100% load	<0.5 ms	<0.5 ms	<0.5 ms	<0.5 ms
OVP调节范围	OVP adjustment	3.8...4.5 V	6.0...6.7 V	16.5...18.0 V	29.0...33.0 V
输出电流 / 功率	Output current / power	24 A / 87 W	24 A / 132 W	10.7 A / 150 W	6.3 A / 150 W
输出电流限制	Output current limit	<28 A	<28 A	<12.8 A	<7.5 A
订购编号	Ordering number	08130309	08130310	08130311	08130312

技术参数	Technical Data	PS 805-12-150 Double		PS 805-24-150 Double	
直流输出电压	Output voltage DC	5 V (4.8...5.5 V)	12 V (11.8...15.2 V)	5 V (4.8...5.5 V)	24 V (23.8...27.2 V)
0...100% I <sub>out</sub> 的负载调整率	Load regulation 0...100% I <sub>out</sub>	<0.05%	<0.2%	<0.05%	<0.2%
100% I <sub>out</sub> 的线性调整率	Line regulation 100% I <sub>out</sub>	<0.05%	<0.2%	<0.05%	<0.2%
LF纹波	Ripple LF	<40 mV <sub>pp</sub>	<40 mV <sub>pp</sub>	<40 mV <sub>pp</sub>	<40 mV <sub>pp</sub>
10-100% 负载调整需时	Regulation time 10-100% load	<0.5 ms	<0.5 ms	<0.5 ms	<0.5 ms
OVP调节范围	OVP adjustment	6.0...6.7 V	16.5...18.0 V	6.0...6.7 V	33.0...36.0 V
输出电流 / 功率	Output current / power	24 A / 150 W	2.5 A	24 A / 150 W	2.5 A
输出电流限制	Output current limit	<28 A	<3.0 A	<28 A	<3.0 A
订购编号	Ordering number	08130313		08130314	

技术参数	Technical Data	PS 812-12-150 Double		PS 812-24-150 Double	
直流输出电压	Output voltage DC	12 V (11.8...15.2 V)	12 V (11.8...15.2 V)	12 V (11.8...15.2 V)	24 V (23.8...27.2 V)
0...100% I <sub>out</sub> 的负载调整率	Load regulation 0...100% I <sub>out</sub>	<0.05%	<0.2%	<0.05%	<0.2%
100% I <sub>out</sub> 的线性调整率	Line regulation 100% I <sub>out</sub>	<0.05%	<0.2%	<0.05%	<0.2%
LF纹波	Ripple LF	<40 mV <sub>pp</sub>	<40 mV <sub>pp</sub>	<40 mV <sub>pp</sub>	<40 mV <sub>pp</sub>
10-100% 负载调整需时	Regulation time 10-100% load	<0.5 ms	<0.5 ms	<0.5 ms	<0.5 ms
OVP调节范围	OVP adjustment	16.5...18.0 V	16.5...18.0 V	16.5...18.0 V	33.0...36.0 V
输出电流 / 功率	Output current / power	10.7 A / 150 W	2.5 A	10.7 A / 150 W	2.5 A
输出电流限制	Output current limit	<12.8 A	<3.0 A	<12.8 A	<3.0 A
订购编号	Ordering number	08130315		08130316	

技术参数	Technical Data	PS 805-12-12-150 Triple		
直流输出电压	Output voltage DC	5 V (4.8...5.5 V)	+12 V (11.8...15.2 V)	-12 V (11.8...15.2 V)
0...100% I <sub>out</sub> 的负载调整率	Load regulation 0...100% I <sub>out</sub>	<0.05%	<0.2%	<0.2%
100% I <sub>out</sub> 的线性调整率	Line regulation 100% I <sub>out</sub>	<0.05%	<0.2%	<0.2%
LF纹波	Ripple LF	<40 mV <sub>pp</sub>	<40 mV <sub>pp</sub>	<40 mV <sub>pp</sub>
10-100% 负载调整需时	Regulation time 10-100% load	<0.5 ms	<0.5 ms	<0.5 ms
OVP调节范围	OVP adjustment	6.0...6.7 V	16.5...18.0 V	16.5...18.0 V
输出电流 / 功率	Output current / power	24 A / 150 W	2.5 A	2.5 A
输出电流限制	Output current limit	<28 A	<3.0 A	<3.0 A
订购编号	Ordering number	08130317		



**EA-PS 800 19" 80 W - 240 W****240 W**

技术参数	Technical Data	PS 803-240 Single	PS 805-240 Single	PS 812-240 Single	PS 824-240 Single
直流输出电压	Output voltage DC	3.3 V (3.0...3.6 V)	5 V (4.8...5.5 V)	12 V (11.8...15.2 V)	24 V (23.5...28.5 V)
0...100% I <sub>out</sub> 的负载调整率	Load regulation 0...100% I <sub>out</sub>	<0.05%	<0.05%	<0.05%	<0.05%
100% I <sub>out</sub> 的线性调整率	Line regulation 100% I <sub>out</sub>	<0.05%	<0.05%	<0.05%	<0.05%
LF纹波	Ripple LF	<40 mV <sub>pp</sub>	<40 mV <sub>pp</sub>	<40 mV <sub>pp</sub>	<40 mV <sub>pp</sub>
10-100% 负载调整需时	Regulation time 10-100% load	<0.5 ms	<0.5 ms	<0.5 ms	<0.5 ms
OVP调节范围	OVP adjustment	3.8...4.5 V	6.0...6.7 V	16.5...18.0 V	29.0...33.0 V
输出电流 / 功率	Output current / power	30 A / 108 W	30 A / 165 W	16 A / 240 W	10 A / 240 W
输出电流限制	Output current limit	<36 A	<36 A	<19.2 A	<19.2 A
订购编号	Ordering number	08130318	08130319	08130320	08130321

技术参数	Technical Data	PS 805-12-240 Double	PS 805-24-240 Double
直流输出电压	Output voltage DC	5 V (4.8...5.5 V)	12 V (11.8...15.2 V)
0...100% I <sub>out</sub> 的负载调整率	Load regulation 0...100% I <sub>out</sub>	<0.05%	<0.2%
100% I <sub>out</sub> 的线性调整率	Line regulation 100% I <sub>out</sub>	<0.05%	<0.2%
LF纹波	Ripple LF	<40 mV <sub>pp</sub>	<40 mV <sub>pp</sub>
10-100% 负载调整需时	Regulation time 10-100% load	<0.5 ms	<0.5 ms
OVP调节范围	OVP adjustment	6.0...6.7 V	16.5...18.0 V
输出电流 / 功率	Output current / power	30 A / 195 W	2.5 A / 34 A / 225 W
输出电流限制	Output current limit	<36 A	<3.0 A
订购编号	Ordering number	08130322	08130323

技术参数	Technical Data	PS 812-12-240 Double	PS 812-24-240 Double
直流输出电压	Output voltage DC	12 V (11.8...15.2 V)	12 V (11.8...15.2 V)
0...100% I <sub>out</sub> 的负载调整率	Load regulation 0...100% I <sub>out</sub>	<0.05%	<0.2%
100% I <sub>out</sub> 的线性调整率	Line regulation 100% I <sub>out</sub>	<0.05%	<0.2%
LF纹波	Ripple LF	<40 mV <sub>pp</sub>	<40 mV <sub>pp</sub>
10-100% 负载调整需时	Regulation time 10-100% load	<0.5 ms	<0.5 ms
OVP调节范围	OVP adjustment	16.5...18.0 V	16.5...18.0 V
输出电流 / 功率	Output current / power	16 A / 240 W	2.5 A / 16 A / 240 W
输出电流限制	Output current limit	<19.2 A	<3.0 A
订购编号	Ordering number	08130324	08130325

技术参数	Technical Data	PS 805-12-12-240 Triple
直流输出电压	Output voltage DC	5 V (4.8...5.5 V)    +12 V (11.8...15.2 V)    -12 V (11.8...15.2 V)
0...100% I <sub>out</sub> 的负载调整率	Load regulation 0...100% I <sub>out</sub>	<0.05%
100% I <sub>out</sub> 的线性调整率	Line regulation 100% I <sub>out</sub>	<0.05%
LF纹波	Ripple LF	<40 mV <sub>pp</sub>
10-100% 负载调整需时	Regulation time 10-100% load	<0.5 ms
OVP调节范围	OVP adjustment	6.0...6.7 V    16.5...18.0 V    16.5...18.0 V
输出电流 / 功率	Output current / power	30 A / 225 W    2.5 A    2.5 A
输出电流限制	Output current limit	<36 A    <3.0 A    <3.0 A
订购编号	Ordering number	08130326



# EA-PS 800 19" 80 W - 240 W

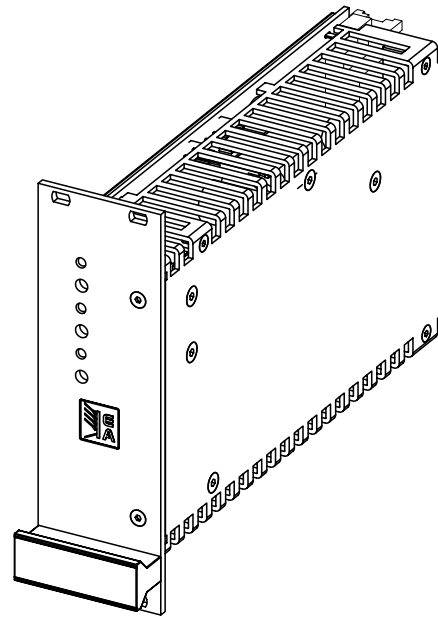
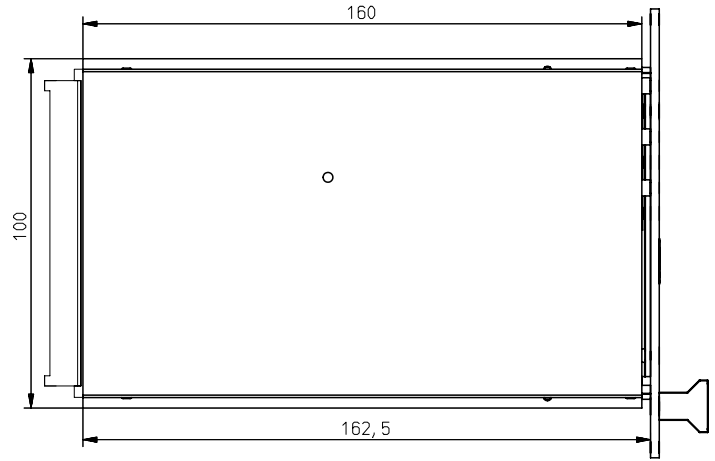
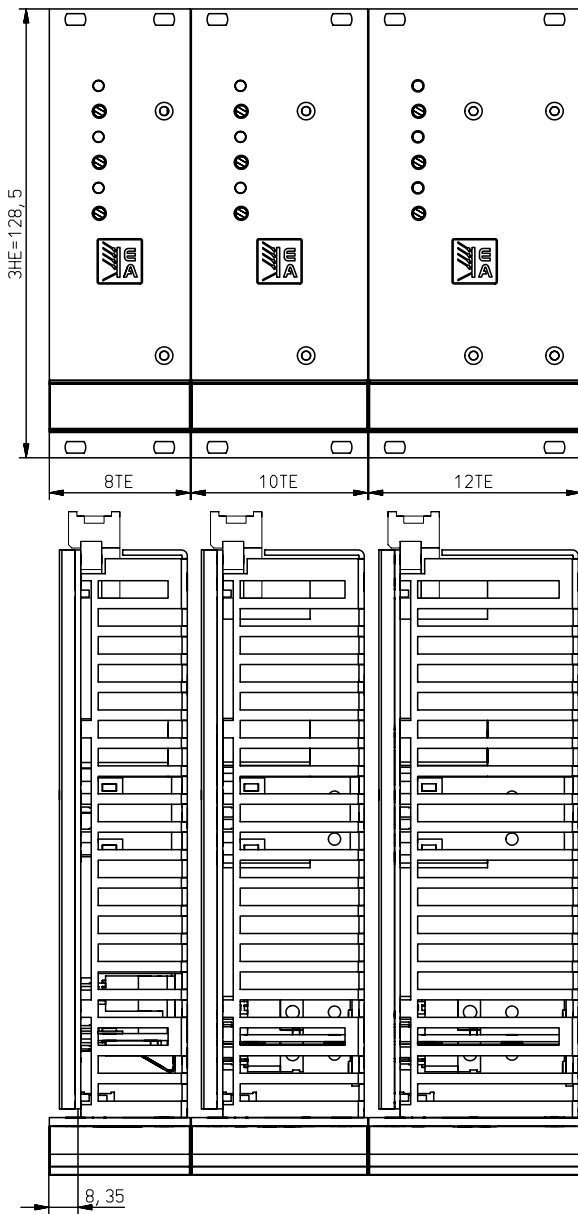

H15连接器	引脚	H15连接器引脚分布图 / Connector H15 pin layout		
Connector H15	Pin	PS 800 19" Single	PS 800 19" Double	PS 800 19" Triple
	4	+V1	+V1	+V1
	6	+V1	+V1	+V1
	8	GND V1	GND V1	GND V1
	10	GND V1	GND V1	GND V1
	12	+Sense	+Sense	+Sense
	14	-Sense	-Sense	-Sense
	16	Power fail / 电源故障	Power fail / 电源故障	Power fail / 电源故障
	18	---	+V2	+V2
	20	--- (optional ASF*)	GND V2	GND V2 / V3
	22	---	---	-V3
	24	Extern On/Off 外部开/关	Extern On/Off / ASF* 外部开/关 / ASF*	Extern On/Off / ASF* 外部开/关 / ASF*
	26	---	---	---
	28	N	N	N
	30	L	L	L
32	PE	PE	PE	

\*ASF = 可选功率共享特性 / optional power sharing feature