

# R&S® ZVAX-TRM

## Extension Unit

### User Manual



1325.1268.02 – 04

This manual describes the following four extension unit models and their options:

- R&S®ZVAX-TRM24, order no. 1322.6500.24
- R&S®ZVAX-TRM40, order no. 1322.6500.40
- R&S®ZVAX-TRM50, order no. 1322.6500.50
- R&S®ZVAX-TRM67, order no. 1322.6500.67

Available options include pulse modulators, output amplifiers, and combiners.

The full set of options is listed in [Chapter 4.2, "Options"](#), on page 27.

© 2015 Rohde & Schwarz GmbH & Co. KG

Mühlhofstr. 15, 81671 München, Germany

Phone: +49 89 41 29 - 0

Fax: +49 89 41 29 12 164

Email: [info@rohde-schwarz.com](mailto:info@rohde-schwarz.com)

Internet: [www.rohde-schwarz.com](http://www.rohde-schwarz.com)

Subject to change – Data without tolerance limits is not binding.

R&S® is a registered trademark of Rohde & Schwarz GmbH & Co. KG.

Trade names are trademarks of the owners.

Throughout this manual R&S® is abbreviated as R&S.

# Basic Safety Instructions

## Always read through and comply with the following safety instructions!

All plants and locations of the Rohde & Schwarz group of companies make every effort to keep the safety standards of our products up to date and to offer our customers the highest possible degree of safety. Our products and the auxiliary equipment they require are designed, built and tested in accordance with the safety standards that apply in each case. Compliance with these standards is continuously monitored by our quality assurance system. The product described here has been designed, built and tested in accordance with the EC Certificate of Conformity and has left the manufacturer's plant in a condition fully complying with safety standards. To maintain this condition and to ensure safe operation, you must observe all instructions and warnings provided in this manual. If you have any questions regarding these safety instructions, the Rohde & Schwarz group of companies will be happy to answer them.

Furthermore, it is your responsibility to use the product in an appropriate manner. This product is designed for use solely in industrial and laboratory environments or, if expressly permitted, also in the field and must not be used in any way that may cause personal injury or property damage. You are responsible if the product is used for any purpose other than its designated purpose or in disregard of the manufacturer's instructions. The manufacturer shall assume no responsibility for such use of the product.

The product is used for its designated purpose if it is used in accordance with its product documentation and within its performance limits (see data sheet, documentation, the following safety instructions). Using the product requires technical skills and, in some cases, a basic knowledge of English. It is therefore essential that only skilled and specialized staff or thoroughly trained personnel with the required skills be allowed to use the product. If personal safety gear is required for using Rohde & Schwarz products, this will be indicated at the appropriate place in the product documentation. Keep the basic safety instructions and the product documentation in a safe place and pass them on to the subsequent users.

Observing the safety instructions will help prevent personal injury or damage of any kind caused by dangerous situations. Therefore, carefully read through and adhere to the following safety instructions before and when using the product. It is also absolutely essential to observe the additional safety instructions on personal safety, for example, that appear in relevant parts of the product documentation. In these safety instructions, the word "product" refers to all merchandise sold and distributed by the Rohde & Schwarz group of companies, including instruments, systems and all accessories. For product-specific information, see the data sheet and the product documentation.

## Safety labels on products

The following safety labels are used on products to warn against risks and dangers.

Symbol	Meaning	Symbol	Meaning
	Notice, general danger location Observe product documentation		ON/OFF Power
	Caution when handling heavy equipment		Standby indication
	Danger of electric shock		Direct current (DC)

## Basic Safety Instructions

Symbol	Meaning	Symbol	Meaning
	Caution ! Hot surface		Alternating current (AC)
	Protective conductor terminal To identify any terminal which is intended for connection to an external conductor for protection against electric shock in case of a fault, or the terminal of a protective earth		Direct/alternating current (DC/AC)
	Earth (Ground)		Class II Equipment to identify equipment meeting the safety requirements specified for Class II equipment (device protected by double or reinforced insulation)
	Frame or chassis Ground terminal		EU labeling for batteries and accumulators For additional information, see section "Waste disposal/Environmental protection", item 1.
	Be careful when handling electrostatic sensitive devices		EU labeling for separate collection of electrical and electronic devices For additional information, see section "Waste disposal/Environmental protection", item 2.
	Warning! Laser radiation For additional information, see section "Operation", item 7.		

### Signal words and their meaning

The following signal words are used in the product documentation in order to warn the reader about risks and dangers.



Indicates a hazardous situation which, if not avoided, will result in death or serious injury.



Indicates a hazardous situation which, if not avoided, could result in death or serious injury.



Indicates a hazardous situation which, if not avoided, could result in minor or moderate injury.



Indicates information considered important, but not hazard-related, e.g. messages relating to property damage.

In the product documentation, the word ATTENTION is used synonymously.

These signal words are in accordance with the standard definition for civil applications in the European Economic Area. Definitions that deviate from the standard definition may also exist in other economic areas or military applications. It is therefore essential to make sure that the signal words described here are always used only in connection with the related product documentation and the related product. The use of signal words in connection with unrelated products or documentation can result in misinterpretation and in personal injury or material damage.

## Basic Safety Instructions

### Operating states and operating positions

*The product may be operated only under the operating conditions and in the positions specified by the manufacturer, without the product's ventilation being obstructed. If the manufacturer's specifications are not observed, this can result in electric shock, fire and/or serious personal injury or death. Applicable local or national safety regulations and rules for the prevention of accidents must be observed in all work performed.*

1. Unless otherwise specified, the following requirements apply to Rohde & Schwarz products: predefined operating position is always with the housing floor facing down, IP protection 2X, use only indoors, max. operating altitude 2000 m above sea level, max. transport altitude 4500 m above sea level. A tolerance of  $\pm 10\%$  shall apply to the nominal voltage and  $\pm 5\%$  to the nominal frequency, overvoltage category 2, pollution degree 2.
2. Do not place the product on surfaces, vehicles, cabinets or tables that for reasons of weight or stability are unsuitable for this purpose. Always follow the manufacturer's installation instructions when installing the product and fastening it to objects or structures (e.g. walls and shelves). An installation that is not carried out as described in the product documentation could result in personal injury or even death.
3. Do not place the product on heat-generating devices such as radiators or fan heaters. The ambient temperature must not exceed the maximum temperature specified in the product documentation or in the data sheet. Product overheating can cause electric shock, fire and/or serious personal injury or even death.

### Electrical safety

*If the information on electrical safety is not observed either at all or to the extent necessary, electric shock, fire and/or serious personal injury or death may occur.*

1. Prior to switching on the product, always ensure that the nominal voltage setting on the product matches the nominal voltage of the mains-supply network. If a different voltage is to be set, the power fuse of the product may have to be changed accordingly.
2. In the case of products of safety class I with movable power cord and connector, operation is permitted only on sockets with a protective conductor contact and protective conductor.
3. Intentionally breaking the protective conductor either in the feed line or in the product itself is not permitted. Doing so can result in the danger of an electric shock from the product. If extension cords or connector strips are implemented, they must be checked on a regular basis to ensure that they are safe to use.
4. If there is no power switch for disconnecting the product from the mains, or if the power switch is not suitable for this purpose, use the plug of the connecting cable to disconnect the product from the mains. In such cases, always ensure that the power plug is easily reachable and accessible at all times. For example, if the power plug is the disconnecting device, the length of the connecting cable must not exceed 3 m. Functional or electronic switches are not suitable for providing disconnection from the AC supply network. If products without power switches are integrated into racks or systems, the disconnecting device must be provided at the system level.
5. Never use the product if the power cable is damaged. Check the power cables on a regular basis to ensure that they are in proper operating condition. By taking appropriate safety measures and carefully laying the power cable, ensure that the cable cannot be damaged and that no one can be hurt by, for example, tripping over the cable or suffering an electric shock.

## Basic Safety Instructions

6. The product may be operated only from TN/TT supply networks fuse-protected with max. 16 A (higher fuse only after consulting with the Rohde & Schwarz group of companies).
7. Do not insert the plug into sockets that are dusty or dirty. Insert the plug firmly and all the way into the socket provided for this purpose. Otherwise, sparks that result in fire and/or injuries may occur.
8. Do not overload any sockets, extension cords or connector strips; doing so can cause fire or electric shocks.
9. For measurements in circuits with voltages  $V_{rms} > 30$  V, suitable measures (e.g. appropriate measuring equipment, fuse protection, current limiting, electrical separation, insulation) should be taken to avoid any hazards.
10. Ensure that the connections with information technology equipment, e.g. PCs or other industrial computers, comply with the IEC 60950-1 / EN 60950-1 or IEC 61010-1 / EN 61010-1 standards that apply in each case.
11. Unless expressly permitted, never remove the cover or any part of the housing while the product is in operation. Doing so will expose circuits and components and can lead to injuries, fire or damage to the product.
12. If a product is to be permanently installed, the connection between the protective conductor terminal on site and the product's protective conductor must be made first before any other connection is made. The product may be installed and connected only by a licensed electrician.
13. For permanently installed equipment without built-in fuses, circuit breakers or similar protective devices, the supply circuit must be fuse-protected in such a way that anyone who has access to the product, as well as the product itself, is adequately protected from injury or damage.
14. Use suitable overvoltage protection to ensure that no overvoltage (such as that caused by a bolt of lightning) can reach the product. Otherwise, the person operating the product will be exposed to the danger of an electric shock.
15. Any object that is not designed to be placed in the openings of the housing must not be used for this purpose. Doing so can cause short circuits inside the product and/or electric shocks, fire or injuries.
16. Unless specified otherwise, products are not liquid-proof (see also section "Operating states and operating positions", item 1). Therefore, the equipment must be protected against penetration by liquids. If the necessary precautions are not taken, the user may suffer electric shock or the product itself may be damaged, which can also lead to personal injury.
17. Never use the product under conditions in which condensation has formed or can form in or on the product, e.g. if the product has been moved from a cold to a warm environment. Penetration by water increases the risk of electric shock.
18. Prior to cleaning the product, disconnect it completely from the power supply (e.g. AC supply network or battery). Use a soft, non-linting cloth to clean the product. Never use chemical cleaning agents such as alcohol, acetone or diluents for cellulose lacquers.

## Operation

1. Operating the products requires special training and intense concentration. Make sure that persons who use the products are physically, mentally and emotionally fit enough to do so; otherwise, injuries or material damage may occur. It is the responsibility of the employer/operator to select suitable personnel for operating the products.

## Basic Safety Instructions

2. Before you move or transport the product, read and observe the section titled "Transport".
3. As with all industrially manufactured goods, the use of substances that induce an allergic reaction (allergens) such as nickel cannot be generally excluded. If you develop an allergic reaction (such as a skin rash, frequent sneezing, red eyes or respiratory difficulties) when using a Rohde & Schwarz product, consult a physician immediately to determine the cause and to prevent health problems or stress.
4. Before you start processing the product mechanically and/or thermally, or before you take it apart, be sure to read and pay special attention to the section titled "Waste disposal/Environmental protection", item 1.
5. Depending on the function, certain products such as RF radio equipment can produce an elevated level of electromagnetic radiation. Considering that unborn babies require increased protection, pregnant women must be protected by appropriate measures. Persons with pacemakers may also be exposed to risks from electromagnetic radiation. The employer/operator must evaluate workplaces where there is a special risk of exposure to radiation and, if necessary, take measures to avert the potential danger.
6. Should a fire occur, the product may release hazardous substances (gases, fluids, etc.) that can cause health problems. Therefore, suitable measures must be taken, e.g. protective masks and protective clothing must be worn.
7. Laser products are given warning labels that are standardized according to their laser class. Lasers can cause biological harm due to the properties of their radiation and due to their extremely concentrated electromagnetic power. If a laser product (e.g. a CD/DVD drive) is integrated into a Rohde & Schwarz product, absolutely no other settings or functions may be used as described in the product documentation. The objective is to prevent personal injury (e.g. due to laser beams).
8. EMC classes (in line with EN 55011/CISPR 11, and analogously with EN 55022/CISPR 22, EN 55032/CISPR 32)
  - Class A equipment:  
Equipment suitable for use in all environments except residential environments and environments that are directly connected to a low-voltage supply network that supplies residential buildings  
Note: Class A equipment is intended for use in an industrial environment. This equipment may cause radio disturbances in residential environments, due to possible conducted as well as radiated disturbances. In this case, the operator may be required to take appropriate measures to eliminate these disturbances.
  - Class B equipment:  
Equipment suitable for use in residential environments and environments that are directly connected to a low-voltage supply network that supplies residential buildings

### Repair and service

1. The product may be opened only by authorized, specially trained personnel. Before any work is performed on the product or before the product is opened, it must be disconnected from the AC supply network. Otherwise, personnel will be exposed to the risk of an electric shock.

## Basic Safety Instructions

- Adjustments, replacement of parts, maintenance and repair may be performed only by electrical experts authorized by Rohde & Schwarz. Only original parts may be used for replacing parts relevant to safety (e.g. power switches, power transformers, fuses). A safety test must always be performed after parts relevant to safety have been replaced (visual inspection, protective conductor test, insulation resistance measurement, leakage current measurement, functional test). This helps ensure the continued safety of the product.

### Batteries and rechargeable batteries/cells

*If the information regarding batteries and rechargeable batteries/cells is not observed either at all or to the extent necessary, product users may be exposed to the risk of explosions, fire and/or serious personal injury, and, in some cases, death. Batteries and rechargeable batteries with alkaline electrolytes (e.g. lithium cells) must be handled in accordance with the EN 62133 standard.*

- Cells must not be taken apart or crushed.
- Cells or batteries must not be exposed to heat or fire. Storage in direct sunlight must be avoided. Keep cells and batteries clean and dry. Clean soiled connectors using a dry, clean cloth.
- Cells or batteries must not be short-circuited. Cells or batteries must not be stored in a box or in a drawer where they can short-circuit each other, or where they can be short-circuited by other conductive materials. Cells and batteries must not be removed from their original packaging until they are ready to be used.
- Cells and batteries must not be exposed to any mechanical shocks that are stronger than permitted.
- If a cell develops a leak, the fluid must not be allowed to come into contact with the skin or eyes. If contact occurs, wash the affected area with plenty of water and seek medical aid.
- Improperly replacing or charging cells or batteries that contain alkaline electrolytes (e.g. lithium cells) can cause explosions. Replace cells or batteries only with the matching Rohde & Schwarz type (see parts list) in order to ensure the safety of the product.
- Cells and batteries must be recycled and kept separate from residual waste. Rechargeable batteries and normal batteries that contain lead, mercury or cadmium are hazardous waste. Observe the national regulations regarding waste disposal and recycling.

### Transport

- The product may be very heavy. Therefore, the product must be handled with care. In some cases, the user may require a suitable means of lifting or moving the product (e.g. with a lift-truck) to avoid back or other physical injuries.
- Handles on the products are designed exclusively to enable personnel to transport the product. It is therefore not permissible to use handles to fasten the product to or on transport equipment such as cranes, fork lifts, wagons, etc. The user is responsible for securely fastening the products to or on the means of transport or lifting. Observe the safety regulations of the manufacturer of the means of transport or lifting. Noncompliance can result in personal injury or material damage.
- If you use the product in a vehicle, it is the sole responsibility of the driver to drive the vehicle safely and properly. The manufacturer assumes no responsibility for accidents or collisions. Never use the product in a moving vehicle if doing so could distract the driver of the vehicle. Adequately secure the product in the vehicle to prevent injuries or other damage in the event of an accident.



## Instrucciones de seguridad elementales

### Waste disposal/Environmental protection

1. Specially marked equipment has a battery or accumulator that must not be disposed of with unsorted municipal waste, but must be collected separately. It may only be disposed of at a suitable collection point or via a Rohde & Schwarz customer service center.
2. Waste electrical and electronic equipment must not be disposed of with unsorted municipal waste, but must be collected separately.  
Rohde & Schwarz GmbH & Co. KG has developed a disposal concept and takes full responsibility for take-back obligations and disposal obligations for manufacturers within the EU. Contact your Rohde & Schwarz customer service center for environmentally responsible disposal of the product.
3. If products or their components are mechanically and/or thermally processed in a manner that goes beyond their intended use, hazardous substances (heavy-metal dust such as lead, beryllium, nickel) may be released. For this reason, the product may only be disassembled by specially trained personnel. Improper disassembly may be hazardous to your health. National waste disposal regulations must be observed.
4. If handling the product releases hazardous substances or fuels that must be disposed of in a special way, e.g. coolants or engine oils that must be replenished regularly, the safety instructions of the manufacturer of the hazardous substances or fuels and the applicable regional waste disposal regulations must be observed. Also observe the relevant safety instructions in the product documentation. The improper disposal of hazardous substances or fuels can cause health problems and lead to environmental damage.

For additional information about environmental protection, visit the Rohde & Schwarz website.

## Instrucciones de seguridad elementales

### ¡Es imprescindible leer y cumplir las siguientes instrucciones e informaciones de seguridad!

El principio del grupo de empresas Rohde & Schwarz consiste en tener nuestros productos siempre al día con los estándares de seguridad y de ofrecer a nuestros clientes el máximo grado de seguridad. Nuestros productos y todos los equipos adicionales son siempre fabricados y examinados según las normas de seguridad vigentes. Nuestro sistema de garantía de calidad controla constantemente que sean cumplidas estas normas. El presente producto ha sido fabricado y examinado según el certificado de conformidad de la UE y ha salido de nuestra planta en estado impecable según los estándares técnicos de seguridad. Para poder preservar este estado y garantizar un funcionamiento libre de peligros, el usuario deberá atenerse a todas las indicaciones, informaciones de seguridad y notas de alerta. El grupo de empresas Rohde & Schwarz está siempre a su disposición en caso de que tengan preguntas referentes a estas informaciones de seguridad.

Además queda en la responsabilidad del usuario utilizar el producto en la forma debida. Este producto está destinado exclusivamente al uso en la industria y el laboratorio o, si ha sido expresamente autorizado, para aplicaciones de campo y de ninguna manera deberá ser utilizado de modo que alguna persona/cosa pueda sufrir daño. El uso del producto fuera de sus fines definidos o sin tener en cuenta las instrucciones del fabricante queda en la responsabilidad del usuario. El fabricante no se hace en ninguna forma responsable de consecuencias a causa del mal uso del producto.















## Instrucciones de seguridad elementales

Se parte del uso correcto del producto para los fines definidos si el producto es utilizado conforme a las indicaciones de la correspondiente documentación del producto y dentro del margen de rendimiento definido (ver hoja de datos, documentación, informaciones de seguridad que siguen). El uso del producto hace necesarios conocimientos técnicos y ciertos conocimientos del idioma inglés. Por eso se debe tener en cuenta que el producto solo pueda ser operado por personal especializado o personas instruidas en profundidad con las capacidades correspondientes. Si fuera necesaria indumentaria de seguridad para el uso de productos de Rohde & Schwarz, encontraría la información debida en la documentación del producto en el capítulo correspondiente. Guarde bien las informaciones de seguridad elementales, así como la documentación del producto, y entréguelas a usuarios posteriores.

Tener en cuenta las informaciones de seguridad sirve para evitar en lo posible lesiones o daños por peligros de toda clase. Por eso es imprescindible leer detalladamente y comprender por completo las siguientes informaciones de seguridad antes de usar el producto, y respetarlas durante el uso del producto. Deberán tenerse en cuenta todas las demás informaciones de seguridad, como p. ej. las referentes a la protección de personas, que encontrarán en el capítulo correspondiente de la documentación del producto y que también son de obligado cumplimiento. En las presentes informaciones de seguridad se recogen todos los objetos que distribuye el grupo de empresas Rohde & Schwarz bajo la denominación de "producto", entre ellos también aparatos, instalaciones así como toda clase de accesorios. Los datos específicos del producto figuran en la hoja de datos y en la documentación del producto.

### Señalización de seguridad de los productos

Las siguientes señales de seguridad se utilizan en los productos para advertir sobre riesgos y peligros.

Símbolo	Significado	Símbolo	Significado
	Aviso: punto de peligro general Observar la documentación del producto		Tensión de alimentación de PUESTA EN MARCHA / PARADA
	Atención en el manejo de dispositivos de peso elevado		Indicación de estado de espera (standby)
	Peligro de choque eléctrico		Corriente continua (DC)
	Advertencia: superficie caliente		Corriente alterna (AC)
	Conexión a conductor de protección		Corriente continua / Corriente alterna (DC/AC)
	Conexión a tierra		El aparato está protegido en su totalidad por un aislamiento doble (reforzado)
	Conexión a masa		Distintivo de la UE para baterías y acumuladores Más información en la sección "Eliminación/protección del medio ambiente", punto 1.

## Instrucciones de seguridad elementales

Símbolo	Significado	Símbolo	Significado
	Aviso: Cuidado en el manejo de dispositivos sensibles a la electrostática (ESD)		Distintivo de la UE para la eliminación por separado de dispositivos eléctricos y electrónicos  Más información en la sección "Eliminación/protección del medio ambiente", punto 2.
	Advertencia: rayo láser  Más información en la sección "Funcionamiento", punto 7.		

### Palabras de señal y su significado

En la documentación del producto se utilizan las siguientes palabras de señal con el fin de advertir contra riesgos y peligros.



Indica una situación de peligro que, si no se evita, causa lesiones graves o incluso la muerte.



Indica una situación de peligro que, si no se evita, puede causar lesiones graves o incluso la muerte.



Indica una situación de peligro que, si no se evita, puede causar lesiones leves o moderadas.



Indica información que se considera importante, pero no en relación con situaciones de peligro; p. ej., avisos sobre posibles daños materiales.

En la documentación del producto se emplea de forma sinónima el término CUIDADO.

Las palabras de señal corresponden a la definición habitual para aplicaciones civiles en el área económica europea. Pueden existir definiciones diferentes a esta definición en otras áreas económicas o en aplicaciones militares. Por eso se deberá tener en cuenta que las palabras de señal aquí descritas sean utilizadas siempre solamente en combinación con la correspondiente documentación del producto y solamente en combinación con el producto correspondiente. La utilización de las palabras de señal en combinación con productos o documentaciones que no les correspondan puede llevar a interpretaciones equivocadas y tener por consecuencia daños en personas u objetos.

### Estados operativos y posiciones de funcionamiento

*El producto solamente debe ser utilizado según lo indicado por el fabricante respecto a los estados operativos y posiciones de funcionamiento sin que se obstruya la ventilación. Si no se siguen las indicaciones del fabricante, pueden producirse choques eléctricos, incendios y/o lesiones graves con posible consecuencia de muerte. En todos los trabajos deberán ser tenidas en cuenta las normas nacionales y locales de seguridad del trabajo y de prevención de accidentes.*

## Instrucciones de seguridad elementales

1. Si no se convino de otra manera, es para los productos Rohde & Schwarz válido lo que sigue: como posición de funcionamiento se define por principio la posición con el suelo de la caja para abajo, modo de protección IP 2X, uso solamente en estancias interiores, utilización hasta 2000 m sobre el nivel del mar, transporte hasta 4500 m sobre el nivel del mar. Se aplicará una tolerancia de  $\pm 10\%$  sobre el voltaje nominal y de  $\pm 5\%$  sobre la frecuencia nominal. Categoría de sobrecarga eléctrica 2, índice de suciedad 2.
2. No sitúe el producto encima de superficies, vehículos, estantes o mesas, que por sus características de peso o de estabilidad no sean aptos para él. Siga siempre las instrucciones de instalación del fabricante cuando instale y asegure el producto en objetos o estructuras (p. ej. paredes y estantes). Si se realiza la instalación de modo distinto al indicado en la documentación del producto, se pueden causar lesiones o, en determinadas circunstancias, incluso la muerte.
3. No ponga el producto sobre aparatos que generen calor (p. ej. radiadores o calefactores). La temperatura ambiente no debe superar la temperatura máxima especificada en la documentación del producto o en la hoja de datos. En caso de sobrecalentamiento del producto, pueden producirse choques eléctricos, incendios y/o lesiones graves con posible consecuencia de muerte.

### Seguridad eléctrica

*Si no se siguen (o se siguen de modo insuficiente) las indicaciones del fabricante en cuanto a seguridad eléctrica, pueden producirse choques eléctricos, incendios y/o lesiones graves con posible consecuencia de muerte.*

1. Antes de la puesta en marcha del producto se deberá comprobar siempre que la tensión preseleccionada en el producto coincida con la de la red de alimentación eléctrica. Si es necesario modificar el ajuste de tensión, también se deberán cambiar en caso dado los fusibles correspondientes del producto.
2. Los productos de la clase de protección I con alimentación móvil y enchufe individual solamente podrán enchufarse a tomas de corriente con contacto de seguridad y con conductor de protección conectado.
3. Queda prohibida la interrupción intencionada del conductor de protección, tanto en la toma de corriente como en el mismo producto. La interrupción puede tener como consecuencia el riesgo de que el producto sea fuente de choques eléctricos. Si se utilizan cables alargadores o regletas de enchufe, deberá garantizarse la realización de un examen regular de los mismos en cuanto a su estado técnico de seguridad.
4. Si el producto no está equipado con un interruptor para desconectarlo de la red, o bien si el interruptor existente no resulta apropiado para la desconexión de la red, el enchufe del cable de conexión se deberá considerar como un dispositivo de desconexión. El dispositivo de desconexión se debe poder alcanzar fácilmente y debe estar siempre bien accesible. Si, p. ej., el enchufe de conexión a la red es el dispositivo de desconexión, la longitud del cable de conexión no debe superar 3 m). Los interruptores selectores o electrónicos no son aptos para el corte de la red eléctrica. Si se integran productos sin interruptor en bastidores o instalaciones, se deberá colocar el interruptor en el nivel de la instalación.
5. No utilice nunca el producto si está dañado el cable de conexión a red. Compruebe regularmente el correcto estado de los cables de conexión a red. Asegúrese, mediante las medidas de protección y de instalación adecuadas, de que el cable de conexión a red no pueda ser dañado o de que nadie pueda ser dañado por él, p. ej. al tropezar o por un choque eléctrico.

## Instrucciones de seguridad elementales

6. Solamente está permitido el funcionamiento en redes de alimentación TN/TT aseguradas con fusibles de 16 A como máximo (utilización de fusibles de mayor amperaje solo previa consulta con el grupo de empresas Rohde & Schwarz).
7. Nunca conecte el enchufe en tomas de corriente sucias o llenas de polvo. Introduzca el enchufe por completo y fuertemente en la toma de corriente. La no observación de estas medidas puede provocar chispas, fuego y/o lesiones.
8. No sobrecargue las tomas de corriente, los cables alargadores o las regletas de enchufe ya que esto podría causar fuego o choques eléctricos.
9. En las mediciones en circuitos de corriente con una tensión  $U_{\text{eff}} > 30 \text{ V}$  se deberán tomar las medidas apropiadas para impedir cualquier peligro (p. ej. medios de medición adecuados, seguros, limitación de tensión, corte protector, aislamiento etc.).
10. Para la conexión con dispositivos informáticos como un PC o un ordenador industrial, debe comprobarse que éstos cumplan los estándares IEC60950-1/EN60950-1 o IEC61010-1/EN 61010-1 válidos en cada caso.
11. A menos que esté permitido expresamente, no retire nunca la tapa ni componentes de la carcasa mientras el producto esté en servicio. Esto pone a descubierto los cables y componentes eléctricos y puede causar lesiones, fuego o daños en el producto.
12. Si un producto se instala en un lugar fijo, se deberá primero conectar el conductor de protección fijo con el conductor de protección del producto antes de hacer cualquier otra conexión. La instalación y la conexión deberán ser efectuadas por un electricista especializado.
13. En el caso de dispositivos fijos que no estén provistos de fusibles, interruptor automático ni otros mecanismos de seguridad similares, el circuito de alimentación debe estar protegido de modo que todas las personas que puedan acceder al producto, así como el producto mismo, estén a salvo de posibles daños.
14. Todo producto debe estar protegido contra sobretensión (debida p. ej. a una caída del rayo) mediante los correspondientes sistemas de protección. Si no, el personal que lo utilice quedará expuesto al peligro de choque eléctrico.
15. No debe introducirse en los orificios de la caja del aparato ningún objeto que no esté destinado a ello. Esto puede producir cortocircuitos en el producto y/o puede causar choques eléctricos, fuego o lesiones.
16. Salvo indicación contraria, los productos no están impermeabilizados (ver también el capítulo "Estados operativos y posiciones de funcionamiento", punto 1). Por eso es necesario tomar las medidas necesarias para evitar la entrada de líquidos. En caso contrario, existe peligro de choque eléctrico para el usuario o de daños en el producto, que también pueden redundar en peligro para las personas.
17. No utilice el producto en condiciones en las que pueda producirse o ya se hayan producido condensaciones sobre el producto o en el interior de éste, como p. ej. al desplazarlo de un lugar frío a otro caliente. La entrada de agua aumenta el riesgo de choque eléctrico.
18. Antes de la limpieza, desconecte por completo el producto de la alimentación de tensión (p. ej. red de alimentación o batería). Realice la limpieza de los aparatos con un paño suave, que no se deshilache. No utilice bajo ningún concepto productos de limpieza químicos como alcohol, acetona o diluyentes para lacas nitrocelulósicas.

## Instrucciones de seguridad elementales

### Funcionamiento

1. El uso del producto requiere instrucciones especiales y una alta concentración durante el manejo. Debe asegurarse que las personas que manejen el producto estén a la altura de los requerimientos necesarios en cuanto a aptitudes físicas, psíquicas y emocionales, ya que de otra manera no se pueden excluir lesiones o daños de objetos. El empresario u operador es responsable de seleccionar el personal usuario apto para el manejo del producto.
2. Antes de desplazar o transportar el producto, lea y tenga en cuenta el capítulo "Transporte".
3. Como con todo producto de fabricación industrial no puede quedar excluida en general la posibilidad de que se produzcan alergias provocadas por algunos materiales empleados —los llamados alérgenos (p. ej. el níquel)—. Si durante el manejo de productos Rohde & Schwarz se producen reacciones alérgicas, como p. ej. irritaciones cutáneas, estornudos continuos, enrojecimiento de la conjuntiva o dificultades respiratorias, debe avisarse inmediatamente a un médico para investigar las causas y evitar cualquier molestia o daño a la salud.
4. Antes de la manipulación mecánica y/o térmica o el desmontaje del producto, debe tenerse en cuenta imprescindiblemente el capítulo "Eliminación/protección del medio ambiente", punto 1.
5. Ciertos productos, como p. ej. las instalaciones de radiocomunicación RF, pueden a causa de su función natural, emitir una radiación electromagnética aumentada. Deben tomarse todas las medidas necesarias para la protección de las mujeres embarazadas. También las personas con marcapasos pueden correr peligro a causa de la radiación electromagnética. El empresario/operador tiene la obligación de evaluar y señalar las áreas de trabajo en las que exista un riesgo elevado de exposición a radiaciones.
6. Tenga en cuenta que en caso de incendio pueden desprenderse del producto sustancias tóxicas (gases, líquidos etc.) que pueden generar daños a la salud. Por eso, en caso de incendio deben usarse medidas adecuadas, como p. ej. máscaras antigás e indumentaria de protección.
7. Los productos con láser están provistos de indicaciones de advertencia normalizadas en función de la clase de láser del que se trate. Los rayos láser pueden provocar daños de tipo biológico a causa de las propiedades de su radiación y debido a su concentración extrema de potencia electromagnética. En caso de que un producto Rohde & Schwarz contenga un producto láser (p. ej. un lector de CD/DVD), no debe usarse ninguna otra configuración o función aparte de las descritas en la documentación del producto, a fin de evitar lesiones (p. ej. debidas a irradiación láser).
8. Clases de compatibilidad electromagnética (conforme a EN 55011 / CISPR 11; y en analogía con EN 55022 / CISPR 22, EN 55032 / CISPR 32)
  - Aparato de clase A:  
Aparato adecuado para su uso en todos los entornos excepto en los residenciales y en aquellos conectados directamente a una red de distribución de baja tensión que suministra corriente a edificios residenciales.  
Nota: Los aparatos de clase A están destinados al uso en entornos industriales. Estos aparatos pueden causar perturbaciones radioeléctricas en entornos residenciales debido a posibles perturbaciones guiadas o radiadas. En este caso, se le podrá solicitar al operador que tome las medidas adecuadas para eliminar estas perturbaciones.
  - Aparato de clase B:  
Aparato adecuado para su uso en entornos residenciales, así como en aquellos conectados directamente a una red de distribución de baja tensión que suministra corriente a edificios residenciales.

## Instrucciones de seguridad elementales

### Reparación y mantenimiento

1. El producto solamente debe ser abierto por personal especializado con autorización para ello. Antes de manipular el producto o abrirlo, es obligatorio desconectarlo de la tensión de alimentación, para evitar toda posibilidad de choque eléctrico.
2. El ajuste, el cambio de partes, el mantenimiento y la reparación deberán ser efectuadas solamente por electricistas autorizados por Rohde & Schwarz. Si se reponen partes con importancia para los aspectos de seguridad (p. ej. el enchufe, los transformadores o los fusibles), solamente podrán ser sustituidos por partes originales. Después de cada cambio de partes relevantes para la seguridad deberá realizarse un control de seguridad (control a primera vista, control del conductor de protección, medición de resistencia de aislamiento, medición de la corriente de fuga, control de funcionamiento). Con esto queda garantizada la seguridad del producto.

### Baterías y acumuladores o celdas

*Si no se siguen (o se siguen de modo insuficiente) las indicaciones en cuanto a las baterías y acumuladores o celdas, pueden producirse explosiones, incendios y/o lesiones graves con posible consecuencia de muerte. El manejo de baterías y acumuladores con electrolitos alcalinos (p. ej. celdas de litio) debe seguir el estándar EN 62133.*

1. No deben desmontarse, abrirse ni triturarse las celdas.
2. Las celdas o baterías no deben someterse a calor ni fuego. Debe evitarse el almacenamiento a la luz directa del sol. Las celdas y baterías deben mantenerse limpias y secas. Limpiar las conexiones sucias con un paño seco y limpio.
3. Las celdas o baterías no deben cortocircuitarse. Es peligroso almacenar las celdas o baterías en estuches o cajones en cuyo interior puedan cortocircuitarse por contacto recíproco o por contacto con otros materiales conductores. No deben extraerse las celdas o baterías de sus embalajes originales hasta el momento en que vayan a utilizarse.
4. Las celdas o baterías no deben someterse a impactos mecánicos fuertes indebidos.
5. En caso de falta de estanqueidad de una celda, el líquido vertido no debe entrar en contacto con la piel ni los ojos. Si se produce contacto, lavar con agua abundante la zona afectada y avisar a un médico.
6. En caso de cambio o recarga inadecuados, las celdas o baterías que contienen electrolitos alcalinos (p. ej. las celdas de litio) pueden explotar. Para garantizar la seguridad del producto, las celdas o baterías solo deben ser sustituidas por el tipo Rohde & Schwarz correspondiente (ver lista de recambios).
7. Las baterías y celdas deben reciclarse y no deben tirarse a la basura doméstica. Las baterías o acumuladores que contienen plomo, mercurio o cadmio deben tratarse como residuos especiales. Respete en esta relación las normas nacionales de eliminación y reciclaje.

### Transporte

1. El producto puede tener un peso elevado. Por eso es necesario desplazarlo o transportarlo con precaución y, si es necesario, usando un sistema de elevación adecuado (p. ej. una carretilla elevadora), a fin de evitar lesiones en la espalda u otros daños personales.

## Instrucciones de seguridad elementales

2. Las asas instaladas en los productos sirven solamente de ayuda para el transporte del producto por personas. Por eso no está permitido utilizar las asas para la sujeción en o sobre medios de transporte como p. ej. grúas, carretillas elevadoras de horquilla, carros etc. Es responsabilidad suya fijar los productos de manera segura a los medios de transporte o elevación. Para evitar daños personales o daños en el producto, siga las instrucciones de seguridad del fabricante del medio de transporte o elevación utilizado.
3. Si se utiliza el producto dentro de un vehículo, recae de manera exclusiva en el conductor la responsabilidad de conducir el vehículo de manera segura y adecuada. El fabricante no asumirá ninguna responsabilidad por accidentes o colisiones. No utilice nunca el producto dentro de un vehículo en movimiento si esto pudiera distraer al conductor. Asegure el producto dentro del vehículo debidamente para evitar, en caso de un accidente, lesiones u otra clase de daños.

### Eliminación/protección del medio ambiente

1. Los dispositivos marcados contienen una batería o un acumulador que no se debe desechar con los residuos domésticos sin clasificar, sino que debe ser recogido por separado. La eliminación se debe efectuar exclusivamente a través de un punto de recogida apropiado o del servicio de atención al cliente de Rohde & Schwarz.
2. Los dispositivos eléctricos usados no se deben desechar con los residuos domésticos sin clasificar, sino que deben ser recogidos por separado.  
Rohde & Schwarz GmbH & Co.KG ha elaborado un concepto de eliminación de residuos y asume plenamente los deberes de recogida y eliminación para los fabricantes dentro de la UE. Para desechar el producto de manera respetuosa con el medio ambiente, dirijase a su servicio de atención al cliente de Rohde & Schwarz.
3. Si se trabaja de manera mecánica y/o térmica cualquier producto o componente más allá del funcionamiento previsto, pueden liberarse sustancias peligrosas (povos con contenido de metales pesados como p. ej. plomo, berilio o níquel). Por eso el producto solo debe ser desmontado por personal especializado con formación adecuada. Un desmontaje inadecuado puede ocasionar daños para la salud. Se deben tener en cuenta las directivas nacionales referentes a la eliminación de residuos.
4. En caso de que durante el trato del producto se formen sustancias peligrosas o combustibles que deban tratarse como residuos especiales (p. ej. refrigerantes o aceites de motor con intervalos de cambio definidos), deben tenerse en cuenta las indicaciones de seguridad del fabricante de dichas sustancias y las normas regionales de eliminación de residuos. Tenga en cuenta también en caso necesario las indicaciones de seguridad especiales contenidas en la documentación del producto. La eliminación incorrecta de sustancias peligrosas o combustibles puede causar daños a la salud o daños al medio ambiente.

Se puede encontrar más información sobre la protección del medio ambiente en la página web de Rohde & Schwarz.



# Quality management and environmental management

Certified Quality System  
**ISO 9001**

Certified Environmental System  
**ISO 14001**

## Sehr geehrter Kunde,

Sie haben sich für den Kauf eines Rohde&Schwarz Produktes entschieden. Sie erhalten damit ein nach modernsten Fertigungsmethoden hergestelltes Produkt. Es wurde nach den Regeln unserer Qualitäts- und Umweltmanagementsysteme entwickelt, gefertigt und geprüft. Rohde&Schwarz ist unter anderem nach den Managementsystemen ISO9001 und ISO 14001 zertifiziert.

## Der Umwelt verpflichtet

- Energie-effiziente, RoHS-konforme Produkte
- Kontinuierliche Weiterentwicklung nachhaltiger Umweltkonzepte
- ISO 14001-zertifiziertes Umweltmanagementsystem

## Dear customer,

You have decided to buy a Rohde&Schwarz product. This product has been manufactured using the most advanced methods. It was developed, manufactured and tested in compliance with our quality management and environmental management systems. Rohde&Schwarz has been certified, for example, according to the ISO9001 and ISO 14001 management systems.

## Environmental commitment

- Energy-efficient products
- Continuous improvement in environmental sustainability
- ISO 14001-certified environmental management system

## Cher client,

Vous avez choisi d'acheter un produit Rohde&Schwarz. Vous disposez donc d'un produit fabriqué d'après les méthodes les plus avancées. Le développement, la fabrication et les tests de ce produit ont été effectués selon nos systèmes de management de qualité et de management environnemental. La société Rohde&Schwarz a été homologuée, entre autres, conformément aux systèmes de management ISO 9001 et ISO 14001.

## Engagement écologique

- Produits à efficience énergétique
- Amélioration continue de la durabilité environnementale
- Système de management environnemental certifié selon ISO 14001



# Customer Support

## Technical support – where and when you need it

For quick, expert help with any Rohde & Schwarz equipment, contact one of our Customer Support Centers. A team of highly qualified engineers provides telephone support and will work with you to find a solution to your query on any aspect of the operation, programming or applications of Rohde & Schwarz equipment.

## Up-to-date information and upgrades

To keep your instrument up-to-date and to be informed about new application notes related to your instrument, please send an e-mail to the Customer Support Center stating your instrument and your wish. We will take care that you will get the right information.

### Europe, Africa, Middle East

Phone +49 89 4129 12345  
[customersupport@rohde-schwarz.com](mailto:customersupport@rohde-schwarz.com)

### North America

Phone 1-888-TEST-RSA (1-888-837-8772)  
[customer.support@rsa.rohde-schwarz.com](mailto:customer.support@rsa.rohde-schwarz.com)

### Latin America

Phone +1-410-910-7988  
[customersupport.la@rohde-schwarz.com](mailto:customersupport.la@rohde-schwarz.com)

### Asia/Pacific

Phone +65 65 13 04 88  
[customersupport.asia@rohde-schwarz.com](mailto:customersupport.asia@rohde-schwarz.com)

### China

Phone +86-800-810-8228 /  
+86-400-650-5896  
[customersupport.china@rohde-schwarz.com](mailto:customersupport.china@rohde-schwarz.com)



# Contents

<b>1</b>	<b>About the Extension Unit.....</b>	<b>5</b>
1.1	Features.....	5
1.2	Documentation Overview.....	7
<b>2</b>	<b>Building Blocks and RF Signal Flow.....</b>	<b>9</b>
2.1	Pulse modulators.....	10
2.2	Output Amplifiers.....	10
2.3	Broadband Combiners.....	10
2.4	Direct Generator/Receiver Access.....	11
2.5	RF Signal Flow (w/o combiners).....	11
<b>3</b>	<b>Preparing the Extension Unit for Use.....</b>	<b>13</b>
3.1	Safety Instructions.....	13
3.2	Front Panel Tour.....	14
3.2.1	Standby Key.....	14
3.2.2	USB Connectors.....	15
3.2.3	RF Connectors.....	15
3.2.4	Front Panel Indicator LEDs.....	16
3.3	Rear Panel Tour.....	16
3.3.1	Mains Connector and Switch.....	16
3.3.2	USB FROM NWA.....	16
3.3.3	USB.....	17
3.3.4	CASCADE IN.....	17
3.3.5	EXT PULSE GENERATOR IN / OUT.....	17
3.4	Putting the Extension Unit into Operation.....	18
3.4.1	Unpacking and Checking the Extension Unit.....	18
3.4.2	Instrument Setup.....	19
3.4.3	Bench Top Operation.....	19
3.4.4	Mounting the extension unit in a 19" Rack.....	21
3.4.5	Connecting the extension unit to the R&S ZVA/ZVT.....	22
3.4.6	EMI Protective Measures.....	23
3.4.7	Connecting the Extension Unit to the AC Supply.....	23
3.4.8	Power on and off.....	23

3.4.9	Standby and Ready State.....	24
<b>3.5</b>	<b>Maintenance.....</b>	<b>24</b>
<b>3.6</b>	<b>Storing and Packing.....</b>	<b>25</b>
<b>4</b>	<b>Models and Options.....</b>	<b>27</b>
<b>4.1</b>	<b>Models.....</b>	<b>27</b>
<b>4.2</b>	<b>Options.....</b>	<b>27</b>
4.2.1	Overview.....	28
4.2.2	Pulse Modulators.....	29
4.2.3	Output Amplifiers.....	29
4.2.4	Broadband Combiners.....	29
4.2.5	Low-noise Preamplifiers.....	30
	<b>Index.....</b>	<b>31</b>

# 1 About the Extension Unit

## 1.1 Features

The R&S ZVAX-TRM is a configurable extension unit for the R&S ZVA and R&S ZVT families of vector network analyzers, enabling enhanced measurements with high signal power, pulsed stimuli, two-tone stimuli or a combination thereof. The focus is on performing measurements on active devices such as T/R modules, receivers or power amplifiers without the need to reconnect the DUT ("single connection measurement").

Once the RF connections between network analyzer and extension unit are established, the R&S ZVAX-TRM allows to condition the RF signals generated by the analyzer by looping internal pulse modulators, amplifiers and combiners into the related source paths. Ports 1 and 2 on the extension unit replace the respective ports on the network analyzer. They provide direct access to the source and measurement paths, which can be used to loop user-specific external components (filters, attenuators, isolators, amplifiers etc.) into the related paths. To optimize the measurement performance, the a-wave (reference signal) can be monitored at different points on the source path.

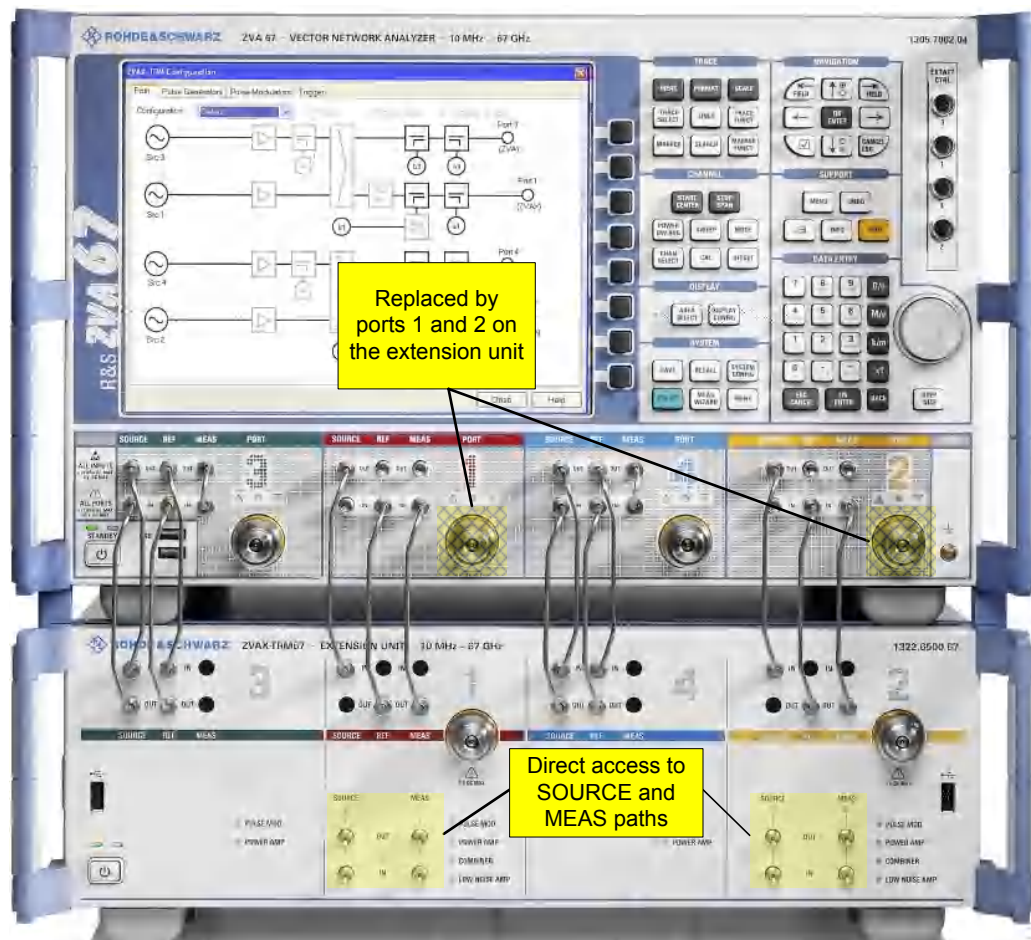

Figure 1-1: 4-port R&S ZVA with extension unit R&S ZVAX-TRM

The extension unit is fully controlled by the analyzer firmware (V3.30 or higher); the management connection is established via USB. Internal components and external user paths of the R&S ZVAX-TRM can be selectively enabled/disabled from the firmware on a per-channel basis. Also, the adequate a-wave access can be selected per channel and port.

The R&S ZVAX-TRM base unit offers two test ports equipped with high-power directional couplers (up to +43 dBm) and supports user-defined source and measurement path extensions via front access connectors. It is available in four variants:

- R&S ZVAX-TRM24: frequency range 10 MHz to 24 GHz (3.5 mm connectors)
- R&S ZVAX-TRM40: frequency range 10 MHz to 40 GHz (2.92 mm connectors)
- R&S ZVAX-TRM50: frequency range 10 MHz to 50 GHz (2.4 mm connectors)
- R&S ZVAX-TRM67: frequency range 10 MHz to 67 GHz (1.85 mm connectors)

Internal signal conditioning modules (pulse modulators, output amplifiers, combiners, low noise preamplifiers) are available as options; see [Chapter 4, "Models and Options"](#), on page 27.

## 1.2 Documentation Overview

The functionality of the R&S ZVAX-TRM extension unit is explained in [Chapter 2, "Building Blocks and RF Signal Flow"](#), on page 9.

For an overview of the front and rear panel controls and connectors of the extension unit see sections [Chapter 3.2, "Front Panel Tour"](#), on page 14, and [Chapter 3.3, "Rear Panel Tour"](#), on page 16.

All information that is necessary to put the unit into operation and to connect it to the network analyzer is given in [Chapter 3.4, "Putting the Extension Unit into Operation"](#), on page 18.

The final chapter describes the available options (see [Chapter 4, "Models and Options"](#), on page 27). These hardware options should be installed in the original unit at time of purchase; later upgrades can only be performed in the Rohde & Schwarz facilities.

For further information, including operation and remote control of the extension unit, refer to the online help system of the R&S ZVA/ZVT network analyzer or its pdf version, both available at the [Rohde&Schwarz Internet site](#).





## 2 Building Blocks and RF Signal Flow

The block diagram below shows a R&S ZVAX-TRM equipped with all available options (see [Chapter 4.2, "Options"](#), on page 27); unavailable modules would be replaced by direct lines.

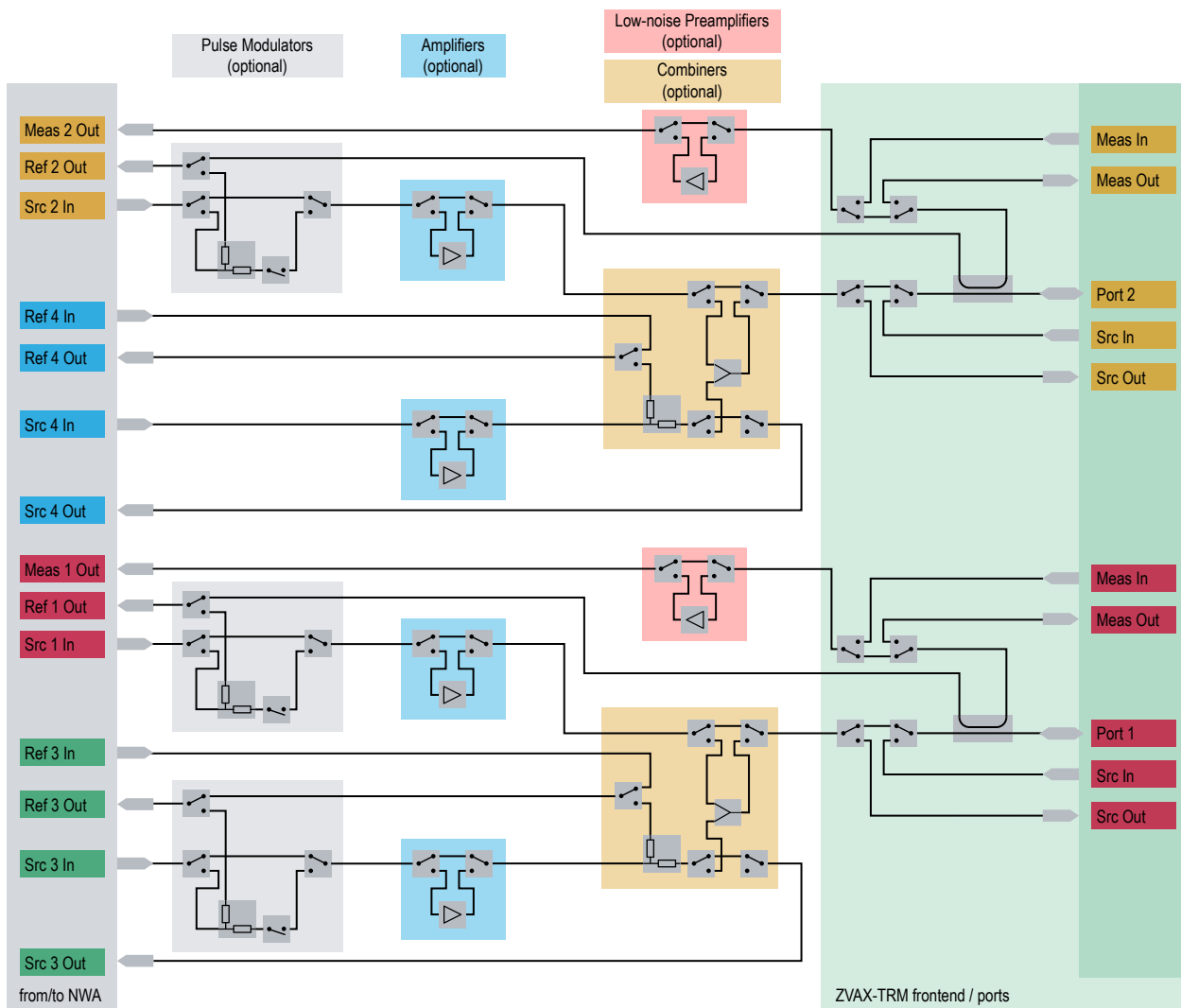

**Figure 2-1: R&S ZVAX-TRM Block Diagram (all options installed)**

Each of the modules can either be looped into the SOURCE or MEAS path or simply bypassed: the transfer switches which are part of each building block, are controlled by the analyzer firmware.



For the 67 GHz model R&S ZVAX-TRM67 we have the following limitations:

- The pulse modulators operate with reduced performance above  $f \approx 60$  GHz.
- The operation range of the low-noise preamplifiers is limited to 50 GHz.

### Reference Signal Access

The block diagram also shows the access points for the reference signal:

- at the pulse modulator (only if the modulator is looped into the source path)
- at the combiner (for paths 3 and 4)
- at the front-end's high-power couplers (for paths 1 and 2)

For paths 3 and 4 the reference signal can also be accessed at the NWA's coupler (see [Chapter 2.5, "RF Signal Flow \(w/o combiners\)"](#), on page 11).



The analyzer firmware ensures that only one of these access points is active at a time.

## 2.1 Pulse modulators

Pulse modulators can be looped into source paths 1, 2 and 3, enabling bidirectional pulsed measurements even on a two-port R&S ZVA. In combination with a R&S ZVA/ZVT with two or more internal generators, IMD measurements with pulsed sources can be performed.

Pulsed measurements are configured in the R&S ZVA/ZVT Firmware (pulse profile measurement requires software option R&S ZVA-K7 at the R&S ZVA/ZVT). To control the pulse modulators of the R&S ZVAX-TRM the analyzer can provide pulse generator signals via the CASCADE interface (see [Chapter 3.3.4, "CASCADE IN"](#), on page 17; requires software option R&S ZVA-K27 at the R&S ZVA/ZVT). If a pulse modulator is looped into the signal path, its input signal can be used as reference signal, which enables ALC even in pulsed measurements (depending on the pulse length).

For the related options, see [Chapter 4.2.2, "Pulse Modulators"](#), on page 29.

## 2.2 Output Amplifiers

Each of the source paths can be equipped with an additional amplifier, intended to compensate for the losses due to other modules and switches on the respective path.

If the amplifier is looped into the source path, output levels similar to those of a stand-alone R&S ZVA/ZVT can be achieved.

For the related options, see [Chapter 4.2.3, "Output Amplifiers"](#), on page 29.

## 2.3 Broadband Combiners

Source paths 1 and 3 (source paths 2 and 4) can be combined and output to port 1 (port 2) on the R&S ZVAX-TRM. With CW source signals the resulting two-tone output signal is suitable for intermodulation measurements. If both combiners are equipped, a

R&S ZVA/ZVT with two internal sources can perform bidirectional intermodulation measurements without having to alter the RF connections.

The built-in monitor switch allows to use the combiner input from path 3 (path 4) as reference signal for port 3 (port 4), even if the combiner is looped into source paths 1 and 3 (source paths 2 and 4).

For the related options, see [Chapter 4.2.4, "Broadband Combiners"](#), on page 29.

## 2.4 Direct Generator/Receiver Access

In order to enable application-specific extensions, the R&S ZVAX-TRM frontend provides access to the source and measurement paths of ports 1 and 2, similar to the "Direct Access" connectors at the R&S ZVA/ZVT. This allows to loop external components (filters, attenuators, isolators, amplifiers etc.) into the related source and/or measurement paths or to connect additional measurement instruments.

Direct generator/receiver access is already part of the base models (see [Chapter 4.1, "Models"](#), on page 27) and doesn't require any additional option.



The external RF path extensions can be bypassed using electronic transfer switches; there is no need to jumper the respective IN/OUT connectors.

---

## 2.5 RF Signal Flow (w/o combiners)

If no combiner is switched into the signal path, ports 1 and 2 are physically provided by the extension unit (ports 1 and 2 of the analyzer are not used):

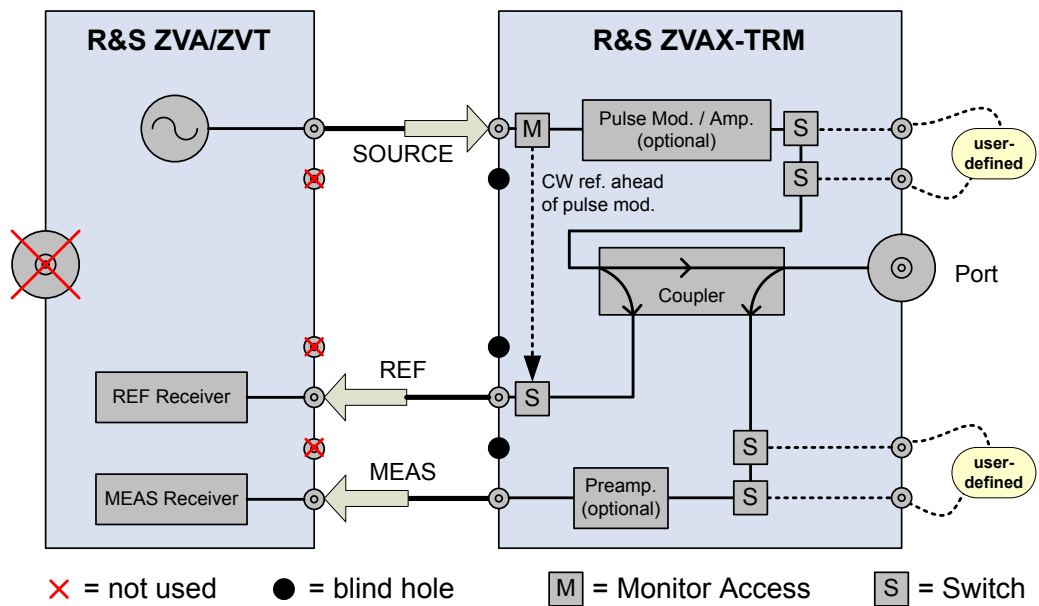

Figure 2-2: RF signal flow for ports 1 and 2 (w/o combiners)

In contrast, ports 3 and 4 are physically provided by the analyzer:

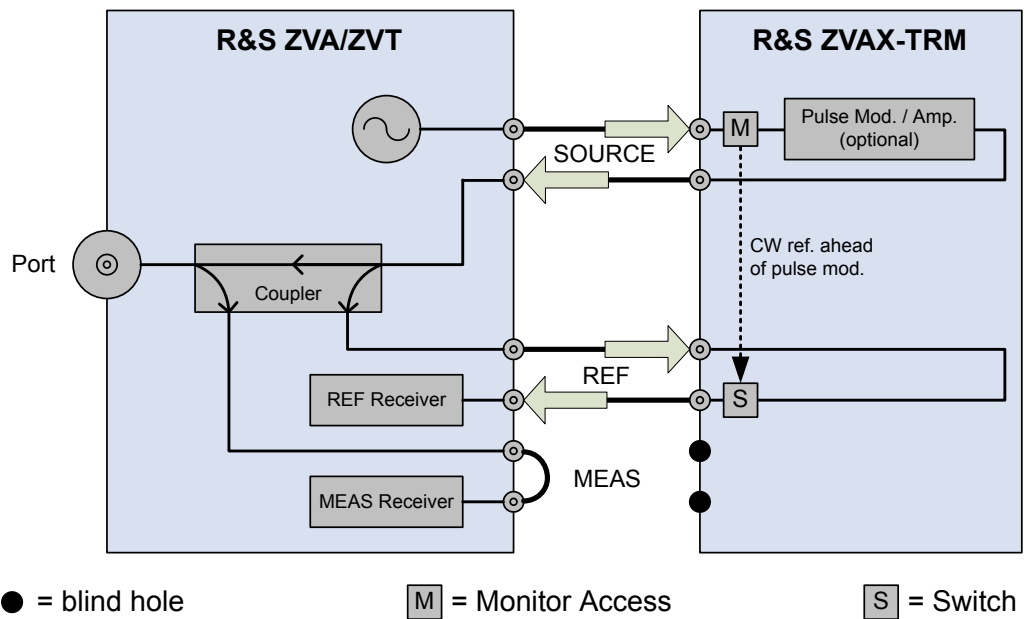

Figure 2-3: RF signal flow for ports 3 and 4 (w/o combiners)

In any case the measurement and reference signals are routed to the MEAS and REF receiver of the analyzer.

## 3 Preparing the Extension Unit for Use

This chapter covers the following topics:

- [Safety Instructions](#)..... 13
- [Front Panel Tour](#)..... 14
- [Rear Panel Tour](#)..... 16
- [Putting the Extension Unit into Operation](#)..... 18
- [Maintenance](#)..... 24
- [Storing and Packing](#)..... 25

### 3.1 Safety Instructions

The extension unit R&S ZVAX-TRM has been designed and tested in accordance with the EC Certificate of Conformity and has left the manufacturer's plant in a condition fully complying with safety standards.

#### CAUTION

##### General safety instructions

To maintain this condition and to ensure safe operation, you must observe all instructions and warnings given in this manual.

##### Maximum Power Levels

The extension unit is intended to be operated with an R&S ZVA or R&S ZVT vector network analyzer (NWA). With regard to the RF power ranges of the extension unit and the network analyzer, there is no risk of damage as long as there are **no external amplifiers or other active devices** looped into the RF paths.

External amplifiers or other active devices may be used to increase the RF power level, as long as the maximum RF powers of the extension unit and the NWA – as quoted in the data sheets – are not exceeded. However, be aware that the power handling capability quoted in the data sheets refers to the couplers only. In order to prevent damage to other components of the extension unit and/or the NWA, the use of external attenuators and/or isolators may be required.

Moreover, observe that the RF signal fed into the extension unit or the NWA must not contain a DC offset, as this may impair the measurements and even cause damage to the extension unit or the NWA.

##### RF Connection

Always connect the extension unit as described in [Chapter 3.4.5, "Connecting the extension unit to the R&S ZVA/ZVT"](#), on page 22. The analyzer firmware expects a 1:1 connection between the ports of the NWA and the ports/paths of the extension unit (1↔1, 2↔2, ...).

### ESD Protective Measures

To protect the extension unit against damage due to Electrostatic Discharge (ESD) use the wrist strap and grounding cord supplied with the network analyzer and connect yourself to the GND connector at the front panel of the R&S ZVA or R&S ZVT. For details refer to the Quick Start Guide of your analyzer.

### USB Connection to the Analyzer

- The extension unit is intended for direct connection to R&S ZVA or R&S ZVT network analyzers according to the instructions in [Chapter 3.4.5, "Connecting the extension unit to the R&S ZVA/ZVT"](#), on page 22 and in the analyzer's help system. Do not connect the unit to other USB hosts, e.g. a PC, and do not insert any USB hubs between the analyzer and the unit, as this may cause damage to the unit or the host.
- It is safe to connect or disconnect the extension unit while the network analyzer is operating. Never connect the unit during a firmware update.

## 3.2 Front Panel Tour

The front panel of the extension unit provides the standby key, two USB connectors (type A), RF connectors for ports 1, 2, 3, and 4, as well as several indicator LEDs.

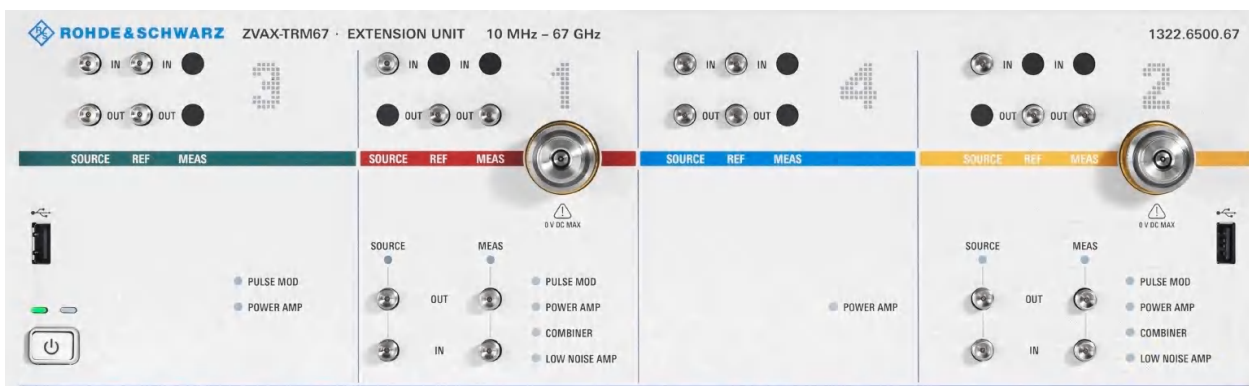

Figure 3-1: R&S ZVAX-TRM Front Panel

### 3.2.1 Standby Key



The standby key connects/disconnects all internal modules of the extension unit to/from the DC supply voltages generated by its internal power supply.

The two LEDs indicate whether the extension unit is ready to operate (green LED on) or in standby state (yellow LED on).



It is recommendable to switch the extension unit to standby state or switch it off by the rear panel AC power switch if it is not used for some time.

### 3.2.2 USB Connectors



The R&S ZVAX-TRM provides two USB type A connectors on the front panel and another one on the rear panel.

Once the extension unit is connected to the network analyzer via the type B USB connector on the rear panel of the extension unit (see [Chapter 3.3.2, "USB FROM NWA"](#), on page 16), the USB type A connectors are functionally equivalent to the USB type A connectors of the network analyzer (USB hub functionality). They can be used to connect supported USB devices (calibration units, power meters, keyboard, mouse, printer, USB stick, etc.) to the R&S ZVA/ZVT.

### 3.2.3 RF Connectors

As shown in [Figure 3-1](#), the R&S ZVAX-TRM provides four groups of RF connectors. The groups are labeled 1 to 4, indicating the related port on the R&S ZVA/ZVT.

The RF connectors in the upper part of the front panel are used to establish the required SOURCE, REF and MEAS paths between analyzer and extension unit (see [Chapter 3.4.5, "Connecting the extension unit to the R&S ZVA/ZVT"](#), on page 22).

Groups 1 and 2 each comprise a **test port connector**, located at the vertical center of the front panel. It is equipped with a high power directional coupler (up to +43 dBm) and replaces the corresponding test port connector on the NWA.

The RF connectors in the lower part of the front panel provide direct access to the SOURCE and MEAS path of ports 1 and 2. If not required, an extension path can be bypassed using electronic transfer switches (controlled by the NWA firmware); there is no need to jumper the IN and OUT connectors.

#### NOTICE

##### Maximum RF power and DC offset

Observe the maximum RF output power at the test ports on the extension unit and the maximum RF input power at the network analyzer ports (see data sheets). If the TX or RX power at the test port connector of the extension unit is high, external attenuators may be required to prevent excess input power at MEAS IN, SOURCE OUT, and REF IN (NWA). These external attenuators can be inserted at the respective port or via the external SRC/MEAS path access.

In addition, it is important that the signal fed in at the test port connector contains no DC offset, as this may impair the measurements and even cause damage to the extension unit.

### 3.2.4 Front Panel Indicator LEDs

As shown in [Figure 3-1](#), the lower part of each port group features several LEDs that indicate whether a particular signal conditioning is currently active for the respective port. For background information, see [Chapter 2, "Building Blocks and RF Signal Flow"](#), on page 9.



Low-noise preamplifiers are not available for the R&S ZVAX-TRM67

## 3.3 Rear Panel Tour

The rear panel contains the mains connector with the AC power switch and several connectors for control and pulse generator signals.



Figure 3-2: R&S ZVAX-TRM Rear Panel

### 3.3.1 Mains Connector and Switch



The mains connector is located in the lefthand part of the rear panel; see also [Chapter 3.4.8, "Power on and off"](#), on page 23.

### 3.3.2 USB FROM NWA



The type B USB connector (slave USB) is used to control the extension unit from an R&S ZVA network analyzer (NWA). Connect the USB FROM NWA connector to any of the type A USB connectors at the front or rear panel of the analyzer.



With an established connection to USB FROM NWA, the type A USB connectors of the extension unit are functionally equivalent to those of the NWA (USB hub functionality).

## NOTICE

### USB connection

The length of the connecting USB cable should not exceed 1 m. It is recommended to use the cable delivered with the extension unit.

### 3.3.3 USB



The USB type A connector on the rear panel is functionally equivalent to the USB type A connectors on the front panel (see [Chapter 3.2.2, "USB Connectors"](#), on page 15).

### 3.3.4 CASCADE IN



Input connector for pulse generator signals from the R&S ZVA/ZVT (via CASCADE OUT; requires option R&S ZVA-K27 on the R&S ZVA/ZVT). Refer to the detailed description of the pulse generator in the help system of your network analyzer.

See the following section for additional information.

### 3.3.5 EXT PULSE GENERATOR IN / OUT

IN/OUT connectors for external pulse generators.



The pulse modulators of the extension unit can be controlled either by the connected R&S ZVA/ZVT (via [CASCADE IN](#)) or by an external pulse generator (via EXT PULSE GENERATOR IN 1, 2).

The analyzer firmware allows to define

- which generator signals shall be used by modulator 1, 2 and 3
- which generator signals shall be fed to EXT PULSE GENERATOR OUT 1 and 2

The pulse PULSE GENERATOR OUT signals are compatible with external pulse generators with a 50 Ω load impedance.

## 3.4 Putting the Extension Unit into Operation

This section describes the basic steps to be taken when setting up the extension unit for the first time.

### **WARNING**

#### **Risk of injury and instrument damage**

The instrument must be used in an appropriate manner to prevent electric shock, fire, personal injury, or damage.

- Do not open the instrument casing.
- Read and observe the "Basic Safety Instructions" delivered as a printed brochure with the instrument.  
In addition, read and observe the safety instructions in the following sections.  
Notice that the data sheet may specify additional operating conditions.

### **NOTICE**

#### **Risk of instrument damage during operation**

An unsuitable operating site or test setup can cause damage to the instrument and to connected devices. Ensure the following operating conditions before you switch on the instrument:

- All fan openings are unobstructed and the airflow perforations are unimpeded. The minimum distance from the wall is 10 cm.
- The instrument is dry and shows no sign of condensation.
- The instrument is positioned as described in the following sections.
- The ambient temperature does not exceed the range specified in the data sheet.
- Signal levels at the input connectors are all within the specified ranges.
- Signal outputs are correctly connected and are not overloaded.

### 3.4.1 Unpacking and Checking the Extension Unit

The extension unit is shipped together with its mandatory accessories in a cardboard box.

In order to unpack its contents proceed as follows:

1. Remove the unit from its packaging and check the equipment for completeness using the delivery note and the accessory lists for the various items.
2. First, pull off the polyethylene protection pads from the unit's rear feet and then carefully remove the pads from the unit handles at the front.
3. Pull off the corrugated cardboard cover that protects the rear of the unit.

4. Carefully unthread the cardboard cover at the front that protects the unit handles and remove it.
5. Check the unit for damage. If you notice any damage, immediately contact the carrier who delivered the unit. In this case, make sure not to discard the box and packing material.

**Packing material**

Retain the original packing material. If the instrument needs to be transported or shipped at a later date, you can use the material to protect the control elements and connectors.

---

### 3.4.2 Instrument Setup

The extension unit is designed for use under laboratory conditions, either on a bench top or in a rack.

The general ambient conditions required at the operating site are as follows:

- The ambient temperature must be in the ranges specified for operation and for compliance with specifications (see data sheet).
- All fan openings including the rear panel perforations must be unobstructed. The distance to the wall should be at least 10 cm.

---

**NOTICE****Electrostatic discharge**

To avoid damage of electronic components of the DUT and the extension unit, the operating site must be protected against electrostatic discharge (ESD). ESD is most likely to occur when you connect or disconnect the extension unit's test ports.

To prevent ESD damage use the wrist strap and grounding cord supplied with the network analyzer and connect yourself to the GND connector at the analyzer's front panel. For additional information refer to the "Instructions for Electrostatic Discharge Protection" on the analyzer's documentation CD-ROM.

---

### 3.4.3 Bench Top Operation

If the extension unit is operated on a bench top, the surface should be flat.

**Stacked Mounting**

The R&S ZVAX-TRM is intended to be mounted underneath a R&S ZVA/ZVT. For this reason the extension unit is delivered with adapters for mechanical fixation, including longer screws (with washers). The adapters requires mounted front handles on both the R&S ZVA/ZVT and the R&S ZVAX-TRM.



*Figure 3-3: R&S ZVA67 stacked on top of R&S ZVAX-TRM, units not yet fixed by adapters and screws*

- 1 = front handles
- 2 = positions for fixing screws

The following steps must be performed in order to mount the stacked units:

1. Place the R&S ZVA/ZVT on top of the R&S ZVAX-TRM; roughly align the front handles.
2. Remove the original fixing screws at positions 2 in [Figure 3-3](#).
3. Position the device adapter to precisely overlap the screw holes.
4. Insert the longer screws with washers and tighten the screws.
5. Repeat the same procedure on the opposite side of the units.



Figure 3-4: Mounting the NWA on top of the extension unit with device adapters and screws

---

**⚠ WARNING**

**Moving stacked units**

The adapters ensure the exact and strainless fit of the semirigid RF cabling to/from R&S ZVA, delivered with the R&S ZVAX-TRM. However, they are not designed to form a single mechanical unit out of the two instruments.

- Use the front handles of the extension unit to position the connected units on the benchtop
- Connected units must be carried horizontally. Grab the extension unit to carry the connected units.

In any case, make sure not to put the connections under mechanical stress.

---

### 3.4.4 Mounting the extension unit in a 19" Rack

The extension unit can be mounted in a 19" rack using the adapter R&S ZZA-211 (order number 1096.3260.00). Mounting instructions are supplied with the rack adapter.

**RF cabling**

The semirigid RF cables delivered with the R&S ZVAX-TRM are tailored for stacked benchtop operation. For rack mounting, with the extension unit directly underneath the R&S ZVA, a different cable set is available and has to be ordered separately (options R&S ZZA-ZVAX).

**NOTICE****Risk of instrument damage in a rack**

An insufficient airflow can cause the instrument to overheat, which may disturb the operation and even cause damage.

Make sure that all fan openings are unobstructed, that the airflow perforations are unimpeded, and that the minimum distance from the wall is 10 cm.

**3.4.5 Connecting the extension unit to the R&S ZVA/ZVT**

After positioning (and mechanical fixation) of NWA and extension unit, the units have to be interconnected.

**1. USB Connection**

Use the "USB type A to USB type B" cable delivered with the R&S ZVAX-TRM to connect a USB type A port of the NWA to the **USB FROM NWA** port of the extension unit

**2. RF Connections**

Connect the SOURCE/REF/MEAS **OUT** connectors in the upper part of the front panel of the extension unit to the corresponding **IN** direct access connectors of the NWA, and vice versa (see [Figure 1-1](#)).

The available connectors depend on the port number and the equipped options.

**3. Pulse Modulator Control**

If the pulse generator of the R&S ZVA/ZVT (with option R&S ZVA-K27) shall be used, connect the CASCADE OUT connector of the NWA to the **CASCADE IN** connector of the extension unit; the required RJ45 cable is delivered with the extension unit.

If an external pulse generator shall be used, connect it to the EXT PULSE GENERATOR IN connectors of the extension unit.



The RF connections between analyzer and extension unit are established via the **Direct Access** connectors of the R&S ZVA/ZVT (equipped with **B16** option). A complete set of semirigid RF cables suitable for connecting a R&S ZVA to a fully equipped R&S ZVAX-TRM in stacked **Bench Top Operation** is provided with the R&S ZVAX-TRM; a cable set for operation in a 19" rack - where instrument feet are omitted and hence shorter cables are required - can be ordered separately (options R&S ZZA-ZVAX).

For the R&S ZVT equivalent cable sets are **not** available.

### 3.4.6 EMI Protective Measures

To avoid electromagnetic interference, the unit may only be operated when it is closed and with all shielding covers fitted. Use only appropriate shielded signal and control cables; see [Chapter 3.2.3, "RF Connectors"](#), on page 15. Observe the EMI classifications of both the R&S ZVAX-TRM and the R&S ZVA in their data sheets.

### 3.4.7 Connecting the Extension Unit to the AC Supply

The extension unit is automatically adapted to the AC supply voltage. The supply voltage must be in the range 100 V to 240 V; 50 Hz to 60 Hz and 400 Hz. The mains connector is located at the rear panel.

- ▶ Connect the extension unit to the AC power source using the AC power cable delivered with the unit.

The maximum and typical power consumption of the extension unit is listed in the data sheet.

### 3.4.8 Power on and off

The mains connector and switch is located at the rear panel.



To turn the power on or off, press the AC power switch to position I (On) or 0 (Off).

After power-on, the extension unit is in standby state.

### 3.4.9 Standby and Ready State

#### CAUTION

##### Shock hazard

The unit is still power-supplied while it is in standby mode.

The standby key connects/disconnects all internal modules of the extension unit to/from the DC supply voltage generated by its internal power supply.



- In standby state (yellow LED on) the power consumption of the unit is very small, however, the internal power supply is still connected to the AC mains power as long as the mains power switch at the rear panel is on.
- In ready state (green LED on) all modules are power-supplied and the unit can be used.

It is recommendable to switch the extension unit to standby state or switch it off by the rear panel AC power switch if it is not used for some time.



#### Switching on the instruments

Switching on the connected extension unit while the network analyzer is booting can cause problems. It is safe to switch on the R&S ZVAX-TRM while the R&S ZVA network analyzer is off or in standby mode, or after it has completed its startup procedure. You can also switch on both instruments before you connect the USB control cable.

## 3.5 Maintenance

The R&S ZVAX-TRM extension unit does not require any special maintenance. Make sure that the air vents are not obstructed. The outside of the unit is suitably cleaned using a soft, lint-free dust cloth.

#### NOTICE

##### Instrument damage caused by cleaning agents

Cleaning agents contain substances that may damage the instrument. For example, cleaning agents that contain a solvent may damage the front panel labeling, plastic parts, or the display.

Never use cleaning agents such as solvents (thinners, acetone, etc), acids, bases, or other substances.

The outside of the instrument can be cleaned sufficiently using a soft, lint-free dust cloth.



For our support center address and a list of useful R&S contact addresses refer to the pages at the beginning of this manual.

### 3.6 Storing and Packing

The extension unit can be stored at the temperature range quoted in the data sheet. When it is stored for a longer period of time the unit should be protected against dust.

The original packing should be used when the unit is to be transported or dispatched. If the original packing is no longer available, use a sturdy cardboard box of suitable size and carefully wrap the unit to protect it against mechanical damage.



## 4 Models and Options

### 4.1 Models

The following table lists the four R&S ZVAX-TRM models:

**Table 4-1: R&S ZVAX-TRM Models**

Model	Order number	Application
R&S ZVAX-TRM <b>24</b>	1322.6500. <b>24</b>	Unit for installation of R&S ZVAX24Bxxx options to extend the measurement capabilities of R&S ZVA and R&S ZVT with "Direct Generator/Receiver Access" 10 MHz to <b>24</b> GHz
R&S ZVAX-TRM <b>40</b>	1322.6500. <b>40</b>	Unit for installation of R&S ZVAX40Bxxx options to extend the measurement capabilities of R&S ZVA and R&S ZVT with "Direct Generator/Receiver Access" 10 MHz to <b>40</b> GHz
R&S ZVAX-TRM <b>50</b>	1322.6500. <b>50</b>	Unit for installation of R&S ZVAX50Bxxx options to extend the measurement capabilities of R&S ZVA and R&S ZVT with "Direct Generator/Receiver Access" 10 MHz to <b>50</b> GHz
R&S ZVAX-TRM <b>67</b>	1322.6500. <b>67</b>	Unit for installation of R&S ZVAX67Bxxx options to extend the measurement capabilities of R&S ZVA and R&S ZVT with "Direct Generator/Receiver Access" 10 MHz to <b>67</b> GHz

### 4.2 Options

The internal signal paths of the R&S ZVAX-TRM can optionally be equipped with pulse modulators, amplifiers and combiners. All available hardware options are specific to a particular extension unit model, i.e. to a certain maximum frequency. Within a particular extension unit model, the available options can be freely combined.

### 4.2.1 Overview

The following graphic and the table below it present the available options.

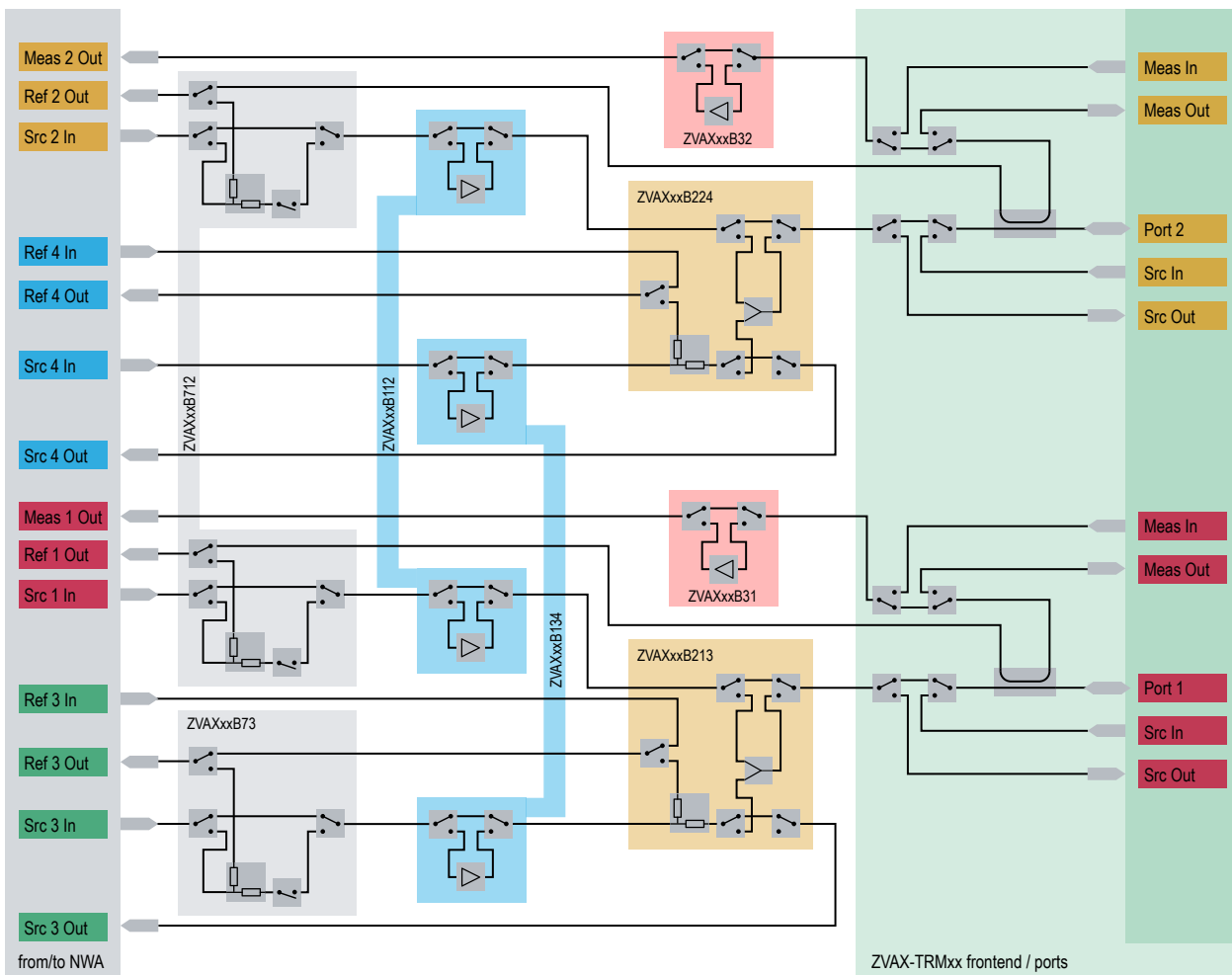

Table 4-2: Option Overview R&S ZVAX-TRMxx (xx = 24, 40, 50, 67)

	Pulse Modulator <sup>(1)</sup>	Src Amplifier	Combiner	Low-noise Receiver Amplifier <sup>(2)</sup>
Path 1	R&S ZVAXxxB712	R&S ZVAXxxB112	R&S ZVAXxxB213: P1 & P3 → P1	R&S ZVAXxxB31
Path 2			R&S ZVAXxxB224: P2 & P4 → P2	R&S ZVAXxxB32
Path 3	R&S ZVAXxxB73	R&S ZVAXxxB134	-	-
Path 4	-		-	-

(1) With reduced performance above  $f \approx 60$  GHz (for R&S ZVAX-TRM67)  
 (2) Operation range limited to 50 GHz (for R&S ZVAX-TRM67)

## 4.2.2 Pulse Modulators

Source paths 1,2 and 3 can be equipped with pulse modulators.

**Table 4-3: R&S ZVAX-TRMxx Pulse Modulator Options (xx = 24, 40, 50, 67)**

Order number	Name	Description
1322.6969.xx	R&S ZVAXxxB712	Pulse modulators for R&S ZVAX-TRMxx to generate pulsed signals at R&S ZVAX-TRMxx Port 1 and Port 2. 10 MHz to xx GHz
1322.6975.xx	R&S ZVAXxxB73	Pulse modulator for R&S ZVAX-TRMxx to generate pulsed signals at NWA Port 3 or R&S ZVAX-TRMxx Port 1 (with option R&S ZVAXxxB213). 10 MHz to xx GHz



For the R&S ZVAX-TRM67 the pulse modulators operate with reduced performance above  $f \approx 60$  GHz.

## 4.2.3 Output Amplifiers

Each source path can be equipped with an output amplifier, e.g. to compensate for losses on the internal source paths (transfer switches, combiners, etc.).

**Table 4-4: R&S ZVAX-TRMxx Output Amplifier Options (xx = 24, 40, 50, 67)**

Order number	Name	Description
1322.6981.xx	R&S ZVAXxxB112	Output amplifiers for R&S ZVAX-TRMxx for increased output power at R&S ZVAX-TRMxx Port 1 and Port 2. 10 MHz to xx GHz
1322.6998.xx	R&S ZVAXxxB134	Output amplifiers for R&S ZVAX-TRMxx for increased output power at NWA port 3 and port 4 or R&S ZVAX-TRMxx Port 1 and Port 2 (with options R&S ZVAXxxB213 and R&S ZVAXxxB224). 10 MHz to xx GHz

## 4.2.4 Broadband Combiners

The source signals of paths 1 and 3 (paths 2 and 4) can be combined to a dual-tone signal and output to port 1 (port 2).

**Table 4-5: R&S ZVAX-TRMxx Combiner Options (xx = 24, 40, 50, 67)**

Order number	Name	Description
1322.7007.xx	R&S ZVAXxxB213	Combiner for R&S ZVAX-TRMxx: Two-tone-signal at R&S ZVAX-TRMxx Port 1 (source 1+3)
1322.7013.xx	R&S ZVAXxxB224	Combiner for R&S ZVAX-TRMxx: Two-tone-signal at R&S ZVAX-TRMxx Port 2 (source 2+4)

## 4.2.5 Low-noise Preamplifiers

The receiver paths of ports 1 and 2 can be equipped with low-noise pre-amplifiers, mainly to support noise figure measurements on DUTs with lower gain.

**Table 4-6: R&S ZVAX-TRMxx LNA Options (xx = 24, 40, 50, 67)**

Order number	Name	Description
1322.7020.xx	R&S ZVAXxxB31	Low-noise preamplifier for R&S ZVAX-TRMxx (measurement path Port 1). 10 MHz to xx GHz
1322.7036.xx	R&S ZVAXxxB32	Low-noise preamplifier for R&S ZVAX-TRMxx (measurement path Port 2). 10 MHz to xx GHz



For the R&S ZVAX-TRM67 the operation range of the low-noise preamplifiers is limited to 50 GHz.

# Index

## Symbols

19" Rack	
mounting .....	21
RF cabling .....	22

## A

AC .....	23
Attenuators .....	11

## B

Bench top operation	
Adapters .....	19
Stacked mounting .....	19
Block Diagram .....	9
Broadband Combiner .....	10

## C

Cabling	
Pulse modulator control .....	22
RF (semi-rigid) .....	22
USB .....	22
CASCADE IN .....	17, 22
Combiners	
Option R&S ZVAXxxB213 .....	29
Option R&S ZVAXxxB224 .....	29
Overview .....	10
Connections	
AC .....	23
physical .....	22
Power supply .....	23
Pulse modulator control .....	22
RF (semi-rigid) .....	22
USB .....	22

## D

Direct generator/receiver access .....	5, 11
--	-------

## E

Electrostatic discharge .....	19
EMI protective measures .....	23
ESD .....	19
EXT PULSE GENERATOR IN .....	17, 22

## F

Filters .....	11
Front panel .....	14
Indicator LEDs .....	16
RF connectors .....	15

## I

Indicator LEDs .....	16
Isolators .....	11

## L

LEDs .....	16
------------	----

## Low noise preamplifiers

Option R&S ZVAXxxB31 .....	30
Option R&S ZVAXxxB32 .....	30

## M

Mains connector .....	16
Mains switch .....	16
Maintenance .....	24
Measurements	
High power .....	5
Pulsed .....	5, 10
Single connection .....	5
Two-tone .....	5
Models .....	27

## O

### Options

Combiners .....	29
Low noise preamplifiers .....	30
Output amplifiers .....	29
Overview .....	28
Pulse modulators .....	29
R&S ZVAXxxB31 .....	30
R&S ZVAXxxB32 .....	30
R&S ZVAXxxB73 .....	29
R&S ZVAXxxB112 .....	29
R&S ZVAXxxB134 .....	29
R&S ZVAXxxB213 .....	29
R&S ZVAXxxB224 .....	29
R&S ZVAXxxB712 .....	29

### Output amplifiers

Option R&S ZVAXxxB112 .....	29
Option R&S ZVAXxxB134 .....	29
Overview .....	10

## P

Packing .....	25
Power amplifiers .....	11
Power on/off .....	23
Power supply .....	23
Pulse generator	
External .....	17
R&S ZVA/ZVT .....	17
PULSE GENERATOR OUT .....	17
Pulse modulator .....	17
Pulse modulators	
control connection .....	17
Control connection .....	22
Option R&S ZVAXxxB73 .....	29
Option R&S ZVAXxxB712 .....	29
Overview .....	10

## R

Rear panel .....	16
CASCADE IN .....	17
EXT PULSE GENERATOR IN .....	17
Mains connector and switch .....	16
PULSE GENERATOR OUT .....	17
USB connector (Type A) .....	17

USB connector (Type B) .....	16
USB FROM NWA .....	16
Reference signal .....	10
RF connectors	
Cabling .....	22
DC offset .....	15
Front panel .....	15
Maximum RF power .....	15
RF signal flow	
ports 1 and 2 .....	11

## S

Safety instructions .....	13
ESD protective measures .....	14
General .....	13
Maximum power levels .....	13
RF connection .....	13
USB connection .....	14
Setup .....	19
Signal conditioning .....	5
Standby key .....	14
Standby vs. ready .....	24
Storing .....	25

## U

Unpacking the instrument .....	18
USB connectors	
Cabling .....	22
Type A .....	15, 17
Type B .....	16
USB FROM NWA .....	16, 22
User path .....	5, 11