

# R&S® ZNB VECTOR NETWORK ANALYZER



Leading in speed, dynamic range  
and ease of operation



Product Brochure  
Version 01.00

**ROHDE & SCHWARZ**  
Make ideas real



# AT A GLANCE

More than 60 years of experience in the field of vector network analysis pay off: Rohde & Schwarz sets new benchmarks with its R&S®ZNB family of vector network analyzers. These analyzers feature high measurement speed, outstanding precision and exceptional ease of operation.

With frequency ranges of 9 kHz to 4.5 GHz/8.5 GHz and 100 kHz to 20 GHz, the network analyzers are targeted at applications in the mobile radio, electronic goods and aerospace and defense sectors, plus they can be used in high speed printed board design. The R&S®ZNB is the right choice when it comes to developing, producing and servicing RF components such as amplifiers, mixers, filters, connectors and cables.

The R&S®ZNB vector network analyzers feature a wide dynamic range of up to 140 dB (at 10 Hz IF bandwidth), low trace noise of less than 0.004 dB RMS (at 10 kHz IF bandwidth) and high output power of up to +13 dBm, which can be adjusted electronically in a range of more than 98 dB.

The R&S®ZNB analyzers combine high measurement accuracy with exceptional speed – better than 5  $\mu$ s per point. They feature excellent temperature and long-term stability, which ensures reliable measurements over several days without having to recalibrate the units.

The short-depth, compact 2-port and 4-port analyzers leave plenty of space on the workbench for the measurement application. They feature low operating noise thanks to low power consumption and a sophisticated cooling concept. Low power consumption also reduces operating costs and protects the environment.

## KEY FACTS

- ▶ Frequency range from 9 kHz up to 20 GHz
- ▶ Wide dynamic range of up to 140 dB
- ▶ Short sweep times, e.g. 4 ms for 401 points
- ▶ High temperature stability of typ. 0.014 dB/K
- ▶ Wide power sweep range of 98 dB
- ▶ Wide range of IF bandwidths from 1 Hz to 10 MHz
- ▶ Manual and automatic calibration
- ▶ Large, high-resolution 12.1" screen
- ▶ Touchscreen user interface
- ▶ 2 or 4 ports
- ▶ 4-port model with two independent internal sources
- ▶ Expansion to up to 48 ports using switch matrices

## BENEFITS

- Designed to meet the highest standards
  - ▶ page 4
- Convenient characterization of active and passive RF components
  - ▶ page 6
- Simple calibration – manual or automatic
  - ▶ page 9
- Network analysis made easy
  - ▶ page 10
- High throughput in production
  - ▶ page 12
- Measurements on up to 48 ports
  - ▶ page 14
- A worthwhile investment
  - ▶ page 16

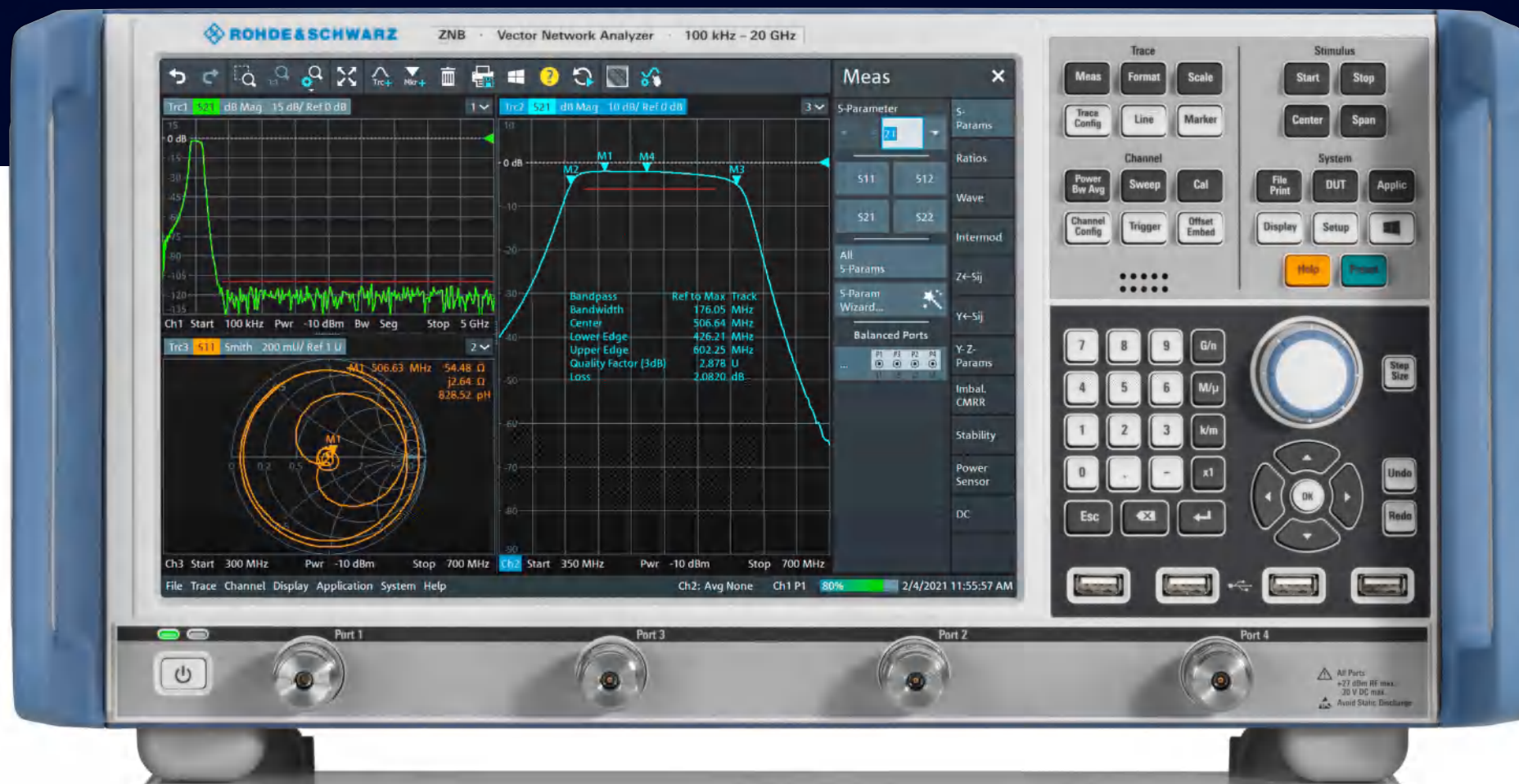

R&S®ZNB models

	9 kHz	100 kHz	4.5 GHz	8.5 GHz	20 GHz
R&S®ZNB20 vector network analyzer 2-port and 4-port, without bias tee					
R&S®ZNB8 vector network analyzer 2-port and 4-port, with bias tee					
R&S®ZNB8 vector network analyzer 2-port and 4-port, without bias tee					
R&S®ZNB4 vector network analyzer 2-port and 4-port, with bias tee					
R&S®ZNB4 vector network analyzer 2-port and 4-port, without bias tee					

# DESIGNED TO MEET THE HIGHEST STANDARDS

The analyzers of the R&S®ZNB family combine wide dynamic range, excellent raw data, high temperature stability and fast synthesizers to yield performance previously found only in high-end network analyzers. This makes the instruments ideally suited for applications in the development and large-scale production of sophisticated RF components.

## Wide dynamic range starting from 9 kHz for fast measurements on high-blocking DUTs

The R&S®ZNB receivers combine high power-handling capacity with high sensitivity and low trace noise. The R&S®ZNB base unit provides typically 140 dB dynamic range (at 10 Hz IF bandwidth), which is better than that of other, comparable products on the market.

The R&S®ZNB4-B52/-B54 and R&S®ZNB8-B52/-B54 options further extend the dynamic range, delivering a value as high as 150 dB for measurements between ports (real dynamic range, i.e. without receivers going into compression at low transmission coefficients). This mainly speeds up manual adjustments on high-blocking filters. Users will benefit from the wide dynamic range of the R&S®ZNB not only in the mobile radio frequency bands, but right from the 9 kHz start frequency.

## Excellent raw data for high basic accuracy

The R&S®ZNB offers directivity of more than 30 dB and uncorrected test port match (i.e. without calibration) of up to 30 dB. Long-term and temperature stability are improved, and accuracy after calibration is increased even further. Even with partial calibration, for example transmission normalization with a through standard, the R&S®ZNB provides accuracy previously achieved only with a relatively complex 2-port calibration – at a speed twice as high as with full 2-port calibration.

## High temperature stability for long calibration intervals

The test set and receivers of the R&S®ZNB feature excellent temperature and long-term stability. The analyzer measures S-parameters with very low magnitude and phase drift of typically less than 0.014 dB/K and 0.035°/GHz/K. A calibrated R&S®ZNB allows precise measurements over several days without recalibration.

## Fast synthesizers for high measurement speed

The R&S®ZNB has fast synthesizers with switching times of below 10 μs. This yields high sweep rates and allows the analyzer to perform measurements faster than competitor products.

R&S®ZNB dynamic range (at 10 Hz IF bandwidth).

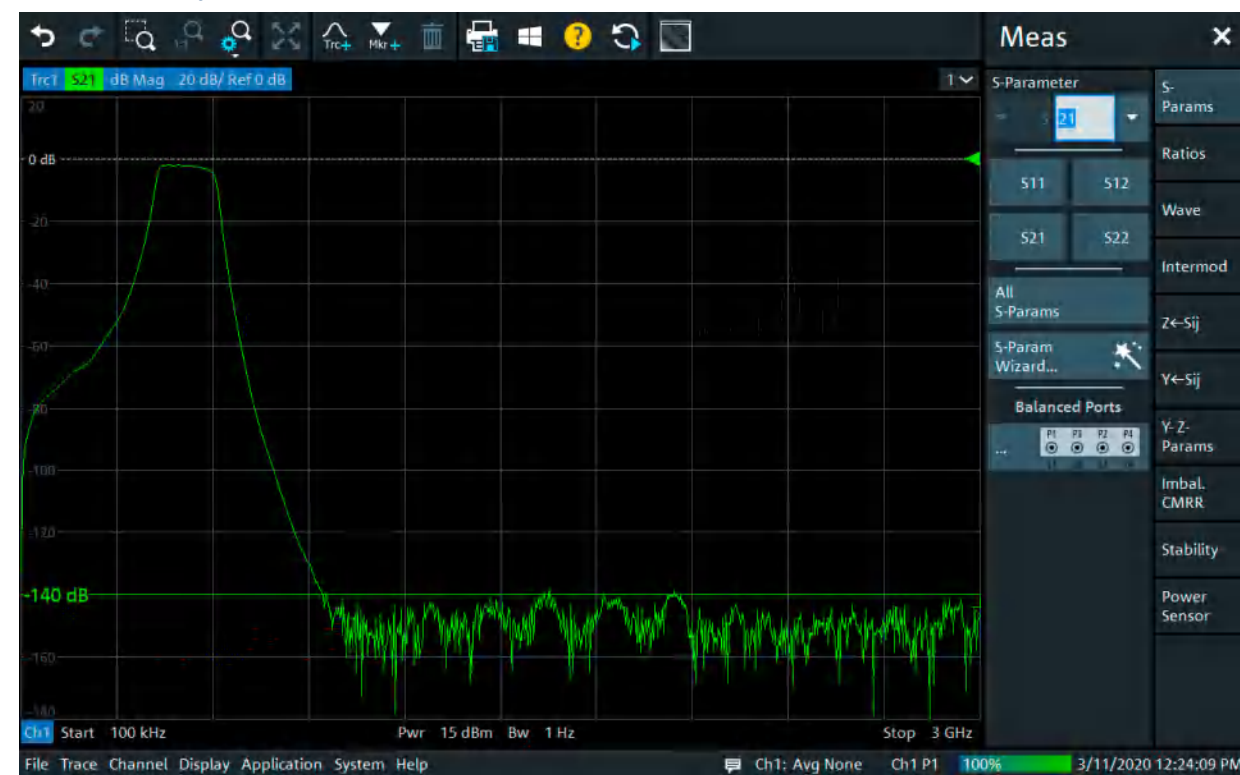

## Block diagram of an R&S®ZNB 4-port model with two internal sources

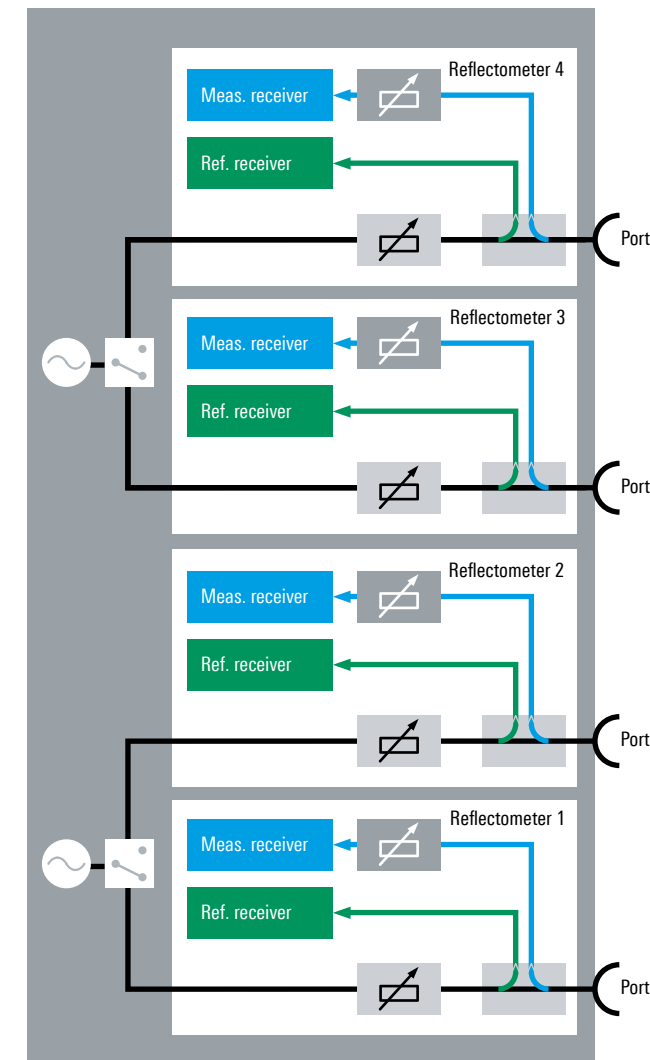

## Block diagram of an R&S®ZNB 2-port model

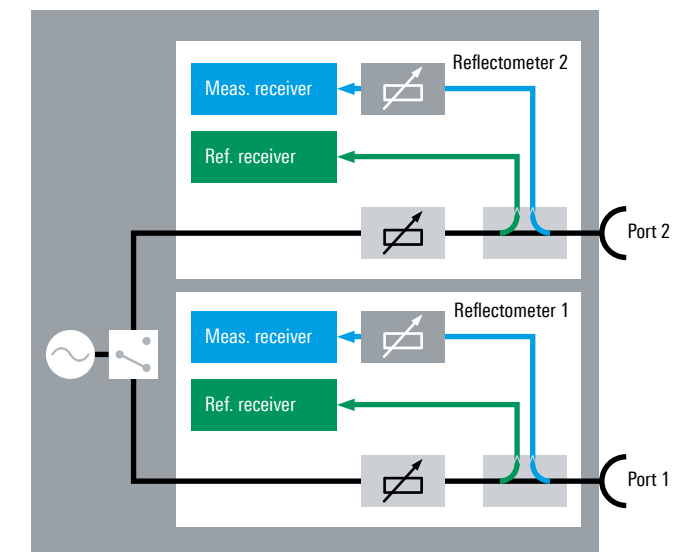



# CONVENIENT CHARACTERIZATION OF ACTIVE AND PASSIVE RF COMPONENTS

## Fast embedding/deembedding for impedance matching using virtual networks

Coaxial and balanced components, such as SAW filters used in mobile phone frontends, are specified together with the networks that match them to the impedance of the surrounding circuit. The R&S®ZNB can embed the DUT into virtual matching networks to provide realistic conditions by simulating the DUT installed in its operational environment. The R&S®ZNB offers a choice of predefined matching network topologies. If values of individual network elements are edited, the R&S®ZNB immediately recalculates the network and embeds the DUT in the new network in real time. In addition to predefined topologies, .s2p, .s4p, .s6p and .s8p files can be read into the R&S®ZNB and used for embedding/deembedding.

## Mixed-mode S-parameters for balanced DUT characterization

To characterize a DUT with two balanced ports, the R&S®ZNB treats the DUT like an unbalanced 4-port device. It calculates the 16 single-ended S-parameters and converts them to mixed-mode S-parameters. This additional computational effort does not compromise measurement speed. A wizard guides the user through the individual steps of the measurement – fast and straightforward.

## Redefined S-parameters for flexible test setup configuration

The R&S®ZNB can be flexibly configured to meet application-specific requirements. The analyzer firmware allows reconfiguring the physical ports by assigning them waves as required for a specific task. This feature can be used to integrate external components into the test set.

## Extensive analysis functions for efficient trace analysis

A wide variety of analysis functions help the user evaluate important parameters at a glance:

- ▶ Up to ten markers per trace
- ▶ Automatic bandwidth measurements
- ▶ Limit line and ripple check with pass/fail indication
- ▶ Statistical trace analysis including maximum, minimum, RMS and peak-to-peak detection as well as compression point measurement
- ▶ Equation editor for complex, real-time trace mathematics

## Redefined S-parameters

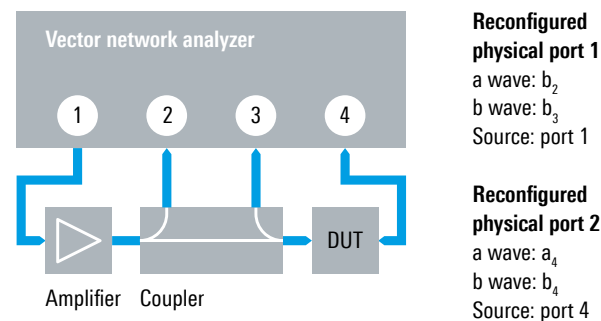
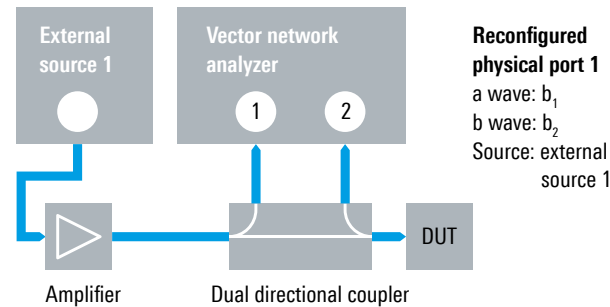

## Impedance matching using virtual networks

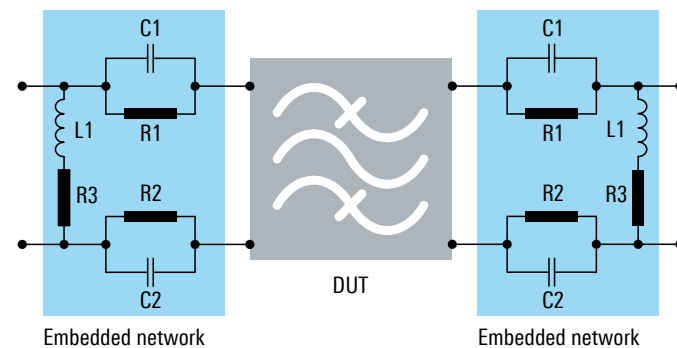

## Amplifier measurements with wide power sweep range and receiver step attenuators

The wide, electronically adjustable power sweep range of the R&S®ZNB from -85 dBm to +13 dBm enables fast analysis of the linear and nonlinear characteristics of small and large-signal amplifiers. Electronic step attenuators in the receive paths increase the 0.1 dB compression point to +27 dBm. The wear-free attenuators feature delay-free switching, which enhances measurement speed and extends the useful life of the R&S®ZNB in production.

Additional features:

- ▶ Four DC inputs for measuring amplifier DC power consumption and efficiency
- ▶ Measurement of stability factors of balanced and unbalanced amplifiers
- ▶ Support of R&S®NRP-Zxx power sensors, providing high-precision power versus power and power versus frequency measurements

## Time domain analysis for distance-to-fault (DTF) measurements and filter adjustment

The R&S®ZNB offers powerful time domain analysis to measure components such as filters or high-speed digital data cables in the frequency and time domain. The extended time domain analysis option makes it possible to display eye diagrams for different bit patterns simultaneously with measurements in the frequency and time domain.

With 100000 points per trace, the R&S®ZNB measures even electrically long DUTs such as long cables without any problems. The gating function of the R&S®ZNB makes it easy to locate cable faults and analyze them in detail.

Using prediction, the analyzer's frequency range can be virtually extended by a factor of up to 10. This yields resolution substantially higher than would be expected from the upper frequency limits of 4.5 GHz, 8.5 GHz and 20 GHz. For many applications, this eliminates the need for a higher-frequency – and more expensive – network analyzer.

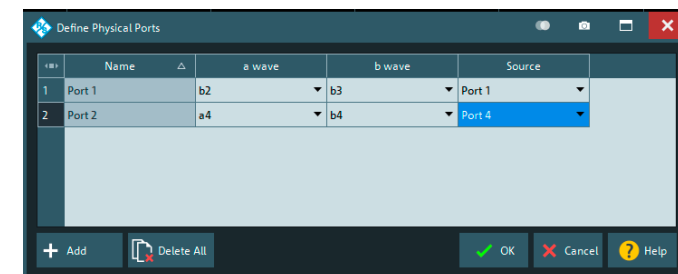

Menu for defining physical ports.

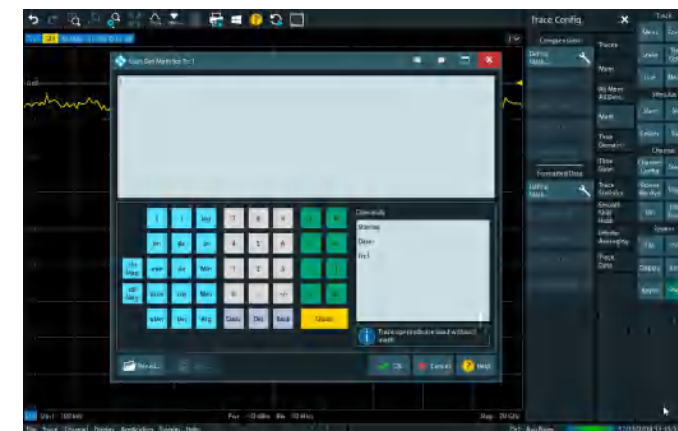

Equation editor for trace mathematics.

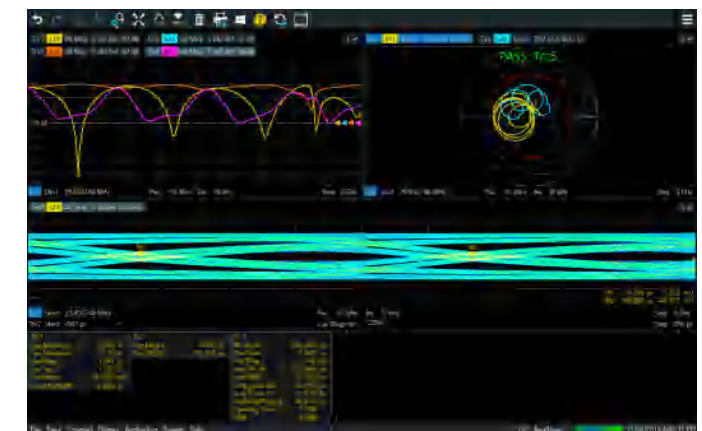

Simultaneous display of eye diagrams and measurements in the frequency and time domain.

**Frequency-converting measurements on mixers and amplifiers – fast and simple with two independent internal sources**

When equipped with the frequency conversion (R&S®ZNB-K4) and intermodulation measurements (R&S®ZNB-K14) options, the R&S®ZNB measures harmonics and intermodulation products on amplifiers as well as conversion loss, matching and isolation on mixers – both in the frequency and time domain. A special calibration technique – R&S®SMARTerCal – combines power calibration with system error correction to precisely determine the magnitude of the conversion loss of mixers. Wizards guide the user step by step to the desired setup and through calibration.

For complex measurements, such as on frontends with multiple mixer stages, the R&S®ZNB can control multiple external signal sources via LAN or IEC/IEEE bus.

The R&S®ZNB 4-port models can optionally be equipped with a second, independent internal source, which can be used, for example, as a local oscillator in mixer measurements or to deliver the second tone in intermodulation measurements. This feature boosts measurement speed by a factor of up to 10 compared with setups using an external, IEC/IEEE bus controlled source. Plus, it significantly simplifies the test setup.

**Typical test setup for a mixer measurement**

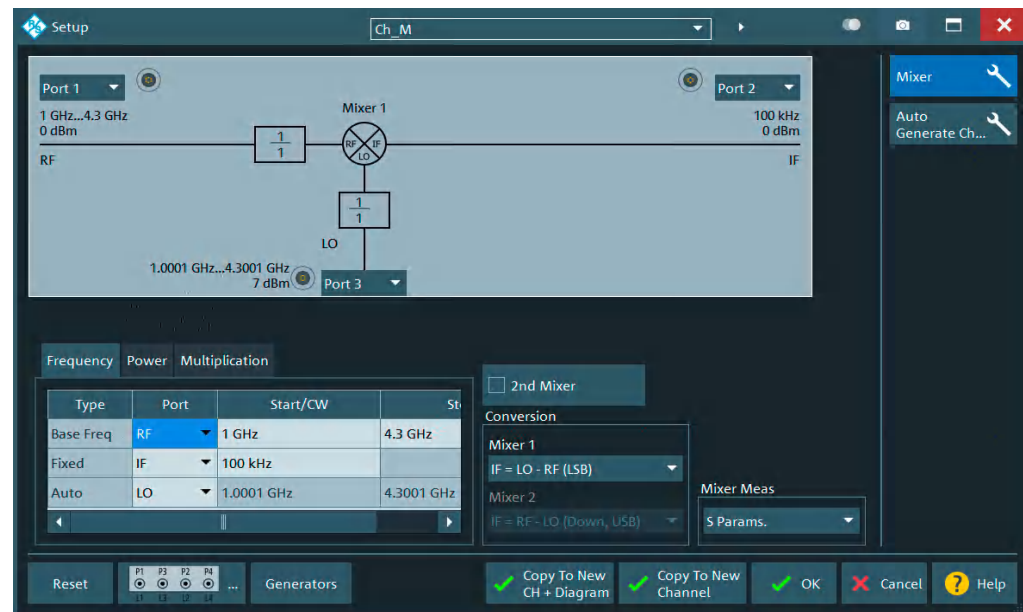
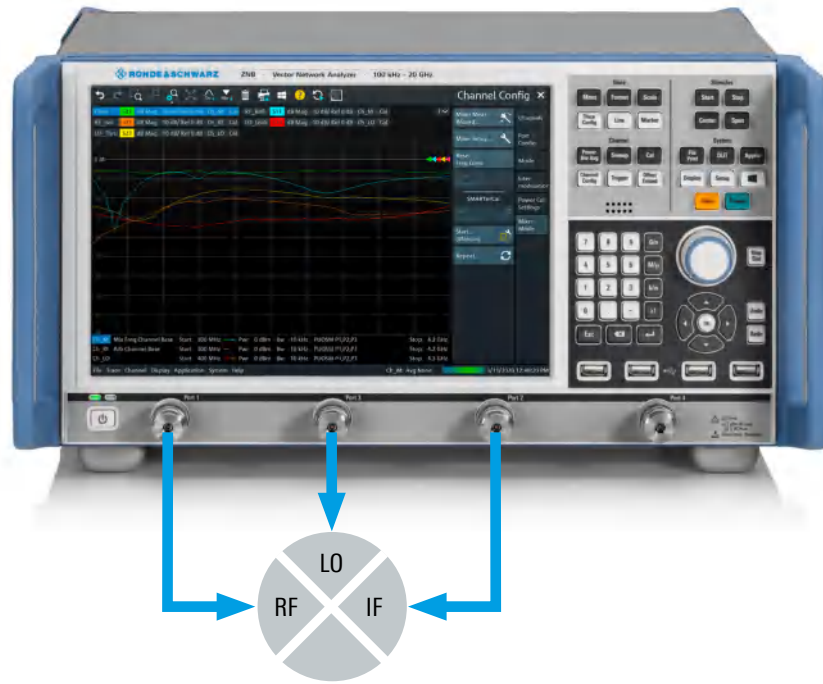

Wizard for configuring mixer measurements.

# SIMPLE CALIBRATION – MANUAL OR AUTOMATIC

**The right calibration for every test application**

The R&S®ZNB supports all common calibration methods for coaxial DUTs as well as calibration methods for measurements on DUTs in test fixtures and on printed boards. Graphical wizards guide the user step by step through the calibration.

- ▶ **TOSM** calibration (**T**hrough, **O**pen, **S**hort, **M**atch)
- ▶ **TRL/LRL** calibration (**T**hrough, **R**eflect, **L**ine/**L**ine, **R**eflect, **L**ine) for printed board based test structures and on-wafer applications
- ▶ **TRM** calibration (**T**hrough, **R**eflect, **M**atch) for applications using test fixtures
- ▶ **UOSM** calibration (**U**nknown **T**hrough, **O**pen, **S**hort, **M**atch) for DUTs equipped with different types of input and output connectors and for calibration with an unknown through standard. Compared with the conventional adapter removal calibration method, this method reduces the number of calibration steps from 14 to 7. This saves time and reduces the risk of calibration errors.

**Through, Short, Match (TSM) – full calibration in only five steps**

A network analyzer's accuracy after calibration essentially depends on the quality of the calibration standards used. The quality of the standards, in turn, depends mainly on how accurately the standards can be described by models. Describing the open standard using a model may be problematic. Rohde&Schwarz therefore created the TSM calibration method for the R&S®ZNB. This method requires only a through, a short and a match; an open standard is not needed. TSM provides accuracy equivalent to that of TOSM, and reduces the number of calibration steps from seven to five.

**Automatic calibration units with up to 24 ports**

Rohde&Schwarz offers automatic calibration units with up to 24 ports. The units are immediately ready for operation when connected to an R&S®ZNB. Users can connect adapters to their calibration units to match different connector types used on the DUT. They can recharacterize the calibration unit, together with the adapters, and store the resulting data to the unit's internal memory. The R&S®ZN-Z51 calibration unit is a special version that can be factory-configured with a mix of connectors.

**Typical effective system data (best value from each frequency range)**

	R&S®ZNB4/ R&S®ZNB8	R&S®ZNB20
Directivity	46 dB	46 dB
Source match	41 dB	43 dB
Load match	45 dB	45 dB
Reflection tracking	0.02 dB	0.05 dB
Transmission tracking	0.018 dB	0.03 dB



R&S®ZN-Z51 4-port calibration unit equipped with different types of connectors.



R&S®ZNB calibration wizard.



# NETWORK ANALYSIS MADE EASY

The R&S®ZNB vector network analyzers turn into reality what many users desire: configuration, measurement and analysis that are truly intuitive.

## Flat and clear menu structures for efficient operation

The R&S®ZNB groups together logically related analyzer control functions at a single operational level, doing away with submenus and multilevel, nested menu structures.

- ▶ The R&S®ZNB features a soft panel that immediately shows all control elements that may be needed for a measurement and effectively helps users perform measurement tasks

- ▶ Via the soft panel, users can access all instrument functions in a maximum of three operating steps
- ▶ Pop-up menus allow many test parameters to be defined right where they are displayed
- ▶ Wizards guide the user through the steps of an operating sequence, for example when calibrating the network analyzer, thereby reducing operator errors to a minimum

## Efficient operation with touch gestures

Whether zooming, moving traces or adding markers: touch gestures make the R&S®ZNB very efficient to operate.

## Optimal display configuration for each measurement task

The R&S®ZNB features a brilliant 12.1" WXGA color touchscreen. The user can set up the display as required by arranging diagrams, traces and channels in any desired combination. Traces can simply be dragged and dropped between diagrams, either with a finger or the mouse. The names of traces, channels and markers can be edited and replaced with user-specific names to make them easier to identify and to provide consistent result documentation.

With the R&S®ZNB, several instrument setups are available simultaneously. The user simply touches or clicks a tab to put the desired setup and diagrams in the foreground and start the associated measurements.

This convenient approach makes it possible to handle different measurement tasks simultaneously without overloading the display with diagrams that are not currently needed.

The user can add further measurements for a given component without modifying the original measurement. This function allows the user to very quickly switch between setups, an essential prerequisite for high throughput in production.

## Toolbar

Fast access to frequently used functions

## Preloaded setups

Switchover between instrument setups by touching or clicking a tab

## More than 100 channels and traces

Fast characterization of sophisticated components

## Pop-up menus

Fast access to desired function

## Widely spaced ports

Easy connection of DUT; plenty of space for connecting test cables

## Large color touchscreen (12.1")

Clearly arranged display of a large number of traces

## Soft panel

Optionally on the right or left, for direct instrument control without submenus



## Logically arranged hardkeys

Just a few keystrokes to desired configuration

## Online help

Context-sensitive, including remote control commands

## Undo/Redo

Cancels or restores the last one to six entries

## USB connectors for auxiliary equipment

Connection of power sensor, automatic calibration unit, mouse/keyboard, memory stick, etc.

## Transparent dialog windows

Traces remain visible

# HIGH THROUGHPUT IN PRODUCTION

## Short measurement times

The R&S®ZNB features short measurement times, a result of fast synthesizer settling times, short sampling times due to large IF bandwidths, high-speed data processing up to the display and fast LAN or IEC/IEEE data transfer to the controller.

The analyzer's large IF bandwidths enable fast sampling times of less than 1 µs per point. The large IF bandwidths, combined with the short synthesizer settling times, yield a total measurement time of no more than 4 ms for a frequency sweep covering 401 points.

## High measurement speed due to wide dynamic range and optimized IF bandwidths

Measurement speed for tests on high-blocking DUTs, such as on base station duplex filters, is determined by the required dynamic range and the corresponding IF bandwidth. The R&S®ZNB features a dynamic range more than 10 dB higher than that of comparable products on the market. This means that, at an IF bandwidth higher by a factor of 10, the R&S®ZNB measures ten times faster than comparable products at the same dynamic range. The R&S®ZNB offers IF bandwidths from 1 Hz to 10 MHz, settable in steps of 1, 1.5, 2, 3, 5, 7 and 10, for optimized speed and dynamic range.

The R&S®ZNB offers up to 140 dB dynamic range for a 10 Hz IF bandwidth. For a sweep with 110 dB dynamic range covering 201 points, the R&S®ZNB requires less than 30 ms, a value that is attractive for base station filter manufacturers.

## Segmented sweep tailored to device under test

When testing high-blocking DUTs such as repeater duplex filters, high IF bandwidths are required in the passband to provide short measurement times. In the stopband, on the other hand, such tests require high output powers and narrow IF bandwidths to provide the required dynamic range.

The segmented sweep function divides the frequency axis into segments. Sweep parameters such as output power, IF bandwidth and number of points can be defined separately for each segment to optimally adapt to the DUT characteristics. This increases measurement speed without any loss in accuracy.

Dialog for configuring a segmented sweep.

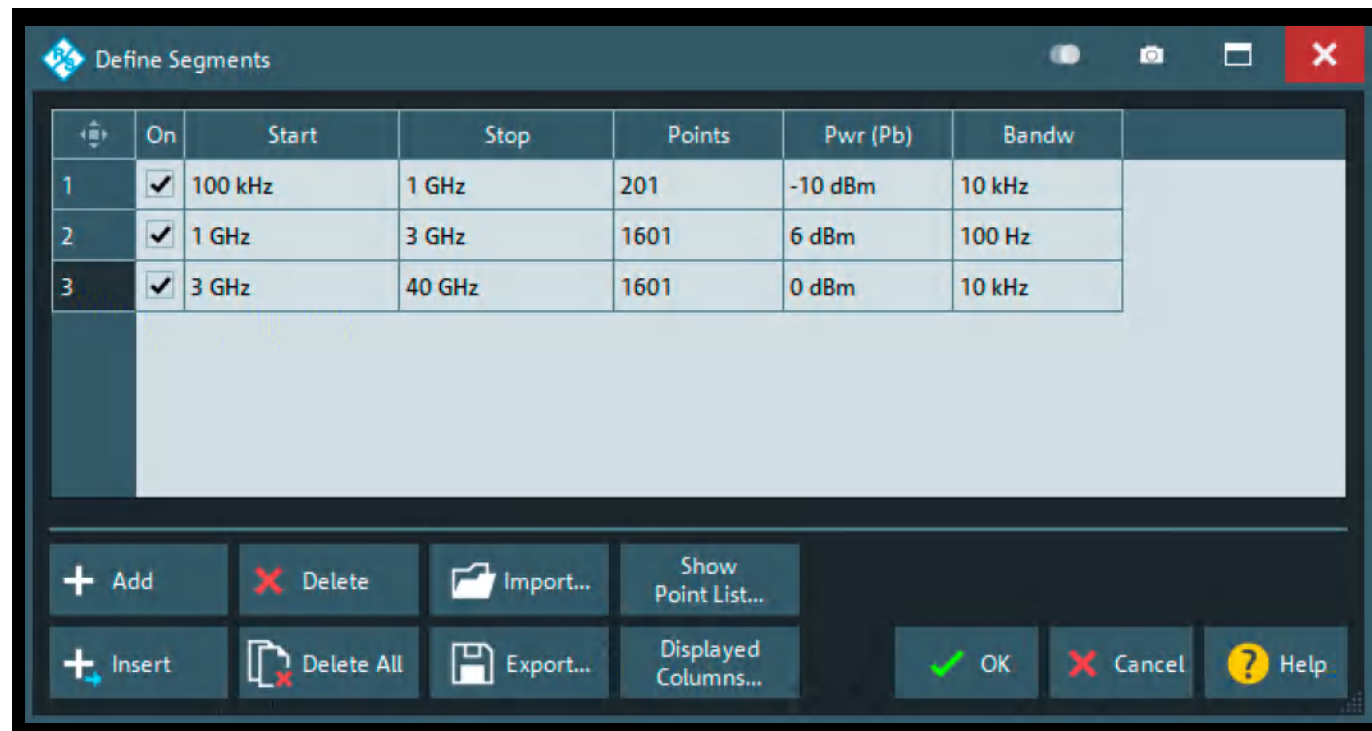

## Fast switching between instrument setups

To carry out complex measurements with different instrument setups, R&S®ZNB users do not need to load the setups from the hard disk each time. Once called, the setups for the required measurements, including calculated data such as calibration values, remain available in RAM. This reduces switching time, especially for measurements involving a large number of points. Switching between setups in remote operation is virtually instantaneous. With manual operation, all the user has to do is touch the screen to activate the setup needed for a desired DUT or measurement.

## Handler I/O interface for communication with external parts handlers

Via the optional handler I/O interface, the R&S®ZNB can communicate with an external parts handler. During a typical test cycle, a parts handler places the DUT into a holder and sends the start signal for the measurement. On completion of the measurement, the parts handler removes the DUT from the holder and sorts it according to predefined criteria. Then the handler places a new DUT in the holder, and the test cycle starts again. The R&S®ZNB can thus be used to deliver fast, reliable results in automated tests, which play a key role especially in production applications.

## GPIO interface with bidirectional data transfer saves time in production

The optional GPIO interface can be used to connect a controller for remote control of the R&S®ZNB. Data is transmitted bidirectionally on the 8-bit parallel bus. The data measured during a sweep is transferred to the controller while the next sweep is already in progress. Data transfer time on the R&S®ZNB is therefore virtually negligible.

## RFFE GPIO interface for direct control of frontend modules

A growing number of components such as filters, switches and amplifiers need to be integrated into the frontend modules of mobile devices such as smartphones and tablets and need to communicate with each other. Here, the RFFE bus defined by the MIPI® Alliance has established itself as the de facto standard. The optional RFFE GPIO interface (external box) allows RF frontend modules in mobile devices to be directly controlled by the R&S®ZNB to carry out measurements with the modules set to diverse operating modes.

Menu for configuring the RFFE GPIO interface.

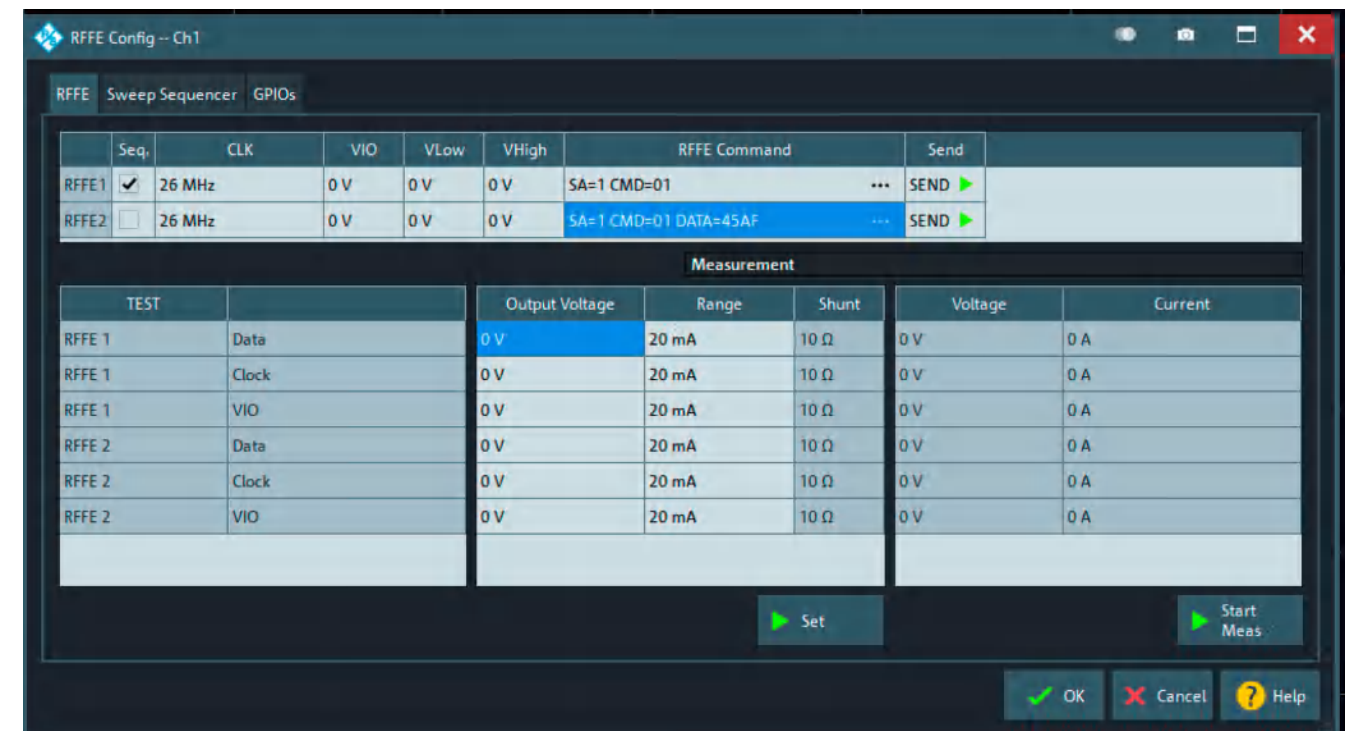



# MEASUREMENTS ON UP TO 48 PORTS

## Expanding the number of ports with switch matrices

Components used in modern communications equipment, e.g. frontend modules in smartphones and tablet PCs, support a growing number of frequency bands and additional functions such as WLAN, Bluetooth® and GPS. As a result, the number of RF ports on these modules is also growing, not least due to the use of differential components. The R&S®ZNB in combination with one or two

switch matrices provides a comprehensive solution for complex measurements on modules with up to 48 ports. The matrices from Rohde&Schwarz deliver full crossbar measurements, allowing all S-parameters of a multiport DUT to be determined.

## Easy configuration at the push of a button

The R&S®ZNB controls switch matrices via LAN, USB or a dedicated digital device control interface. With an R&S®ZNB 4-port model, for example, two switch matrices with two input ports and 24 output ports each can be combined to characterize DUTs with up to 48 ports. Once a matrix is connected, the R&S®ZNB automatically detects the matrix type and assigns the test ports so that users can immediately start measuring. S-parameters, waves and wave ratios are directly selected and displayed on the R&S®ZNB user interface, eliminating the need for additional software or macros to configure and control the setup or measurement.

Automatic assignment of test ports on the R&S®ZNB.

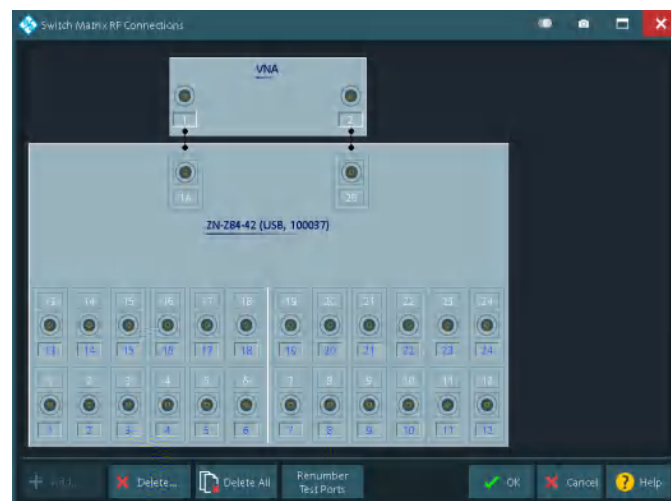

## Mixed configuration: analyzer and switch matrix plus high-performance VNA ports

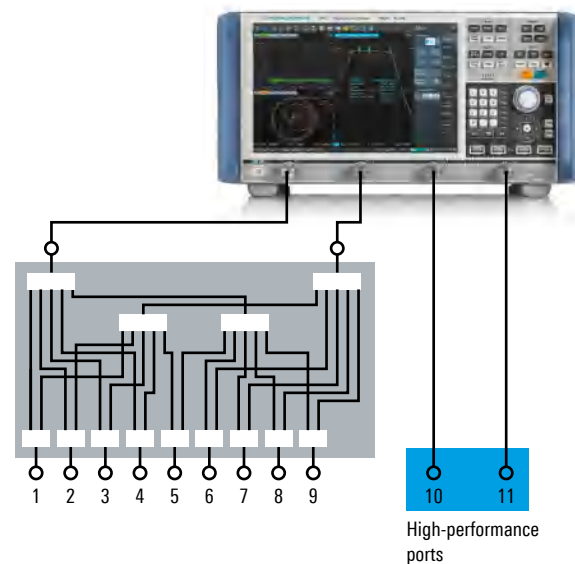

R&S®ZNB with two R&S®ZN-Z84 switch matrices.



## Fast measurements and excellent RF characteristics

The switch matrices from Rohde&Schwarz feature exceptionally short switching times. Via a dedicated device control interface, the R&S®ZNB controls the matrix switches directly and synchronously with its internal test sequences. This yields enhanced measurement speed especially for sweeps covering a small number of points.

Featuring compact design and state-of-the-art electronic switches, the R&S®ZN-Z84 and R&S®ZN-Z85 switch matrices exhibit low insertion loss. Other highlights include good test port match and a high compression point allowing measurements on active DUTs with output power levels up to +20 dBm.

Rohde&Schwarz offers calibration units with up to 24 ports. This enables fast, automated calibration of the R&S®ZNB together with the matrices connected to it.

## Matrix solutions for every application

Rohde&Schwarz offers switch matrices for a variety of applications. Matrix models with two or four inputs and up to 24 outputs are available. Users can select the optimum configuration for low insertion loss, maximum accuracy and a high number of ports. The base unit contains six outputs. The R&S®ZN-Z84 switch matrix can be enhanced to offer up to 24 outputs by adding further ports in groups of six. The R&S®ZN-Z84 covers the frequency range from 10 MHz to 8.5 GHz.

Multiport measurements up to 20 GHz can be performed using an R&S®ZN-Z85 switch matrix together with an R&S®ZNB20 analyzer. The R&S®ZN-Z85 is available with two inputs and six outputs or with four inputs and 12 outputs.

It is also possible to combine a 4-port R&S®ZNB with a matrix with two inputs (mixed configuration). The remaining 2 ports on the network analyzer can be used as regular VNA ports offering the superior performance the R&S®ZNB is known for.

## R&S®ZN-Z84 or R&S®ZN-Z85 switch matrix with 4-port R&S®ZNB, delivering 12 outputs

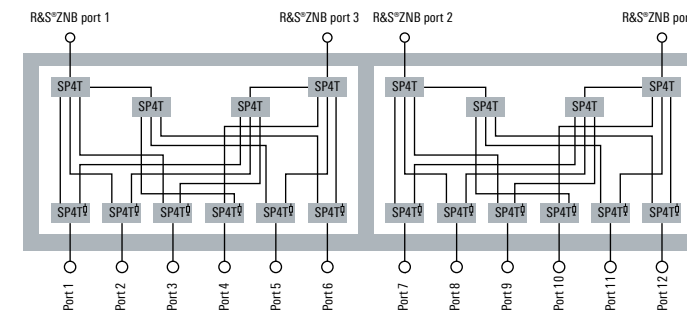

R&S®ZN-Z154 24-port calibration unit.



## R&S®ZN-Z84 switch matrix with 2-port R&S®ZNB, delivering 24 outputs

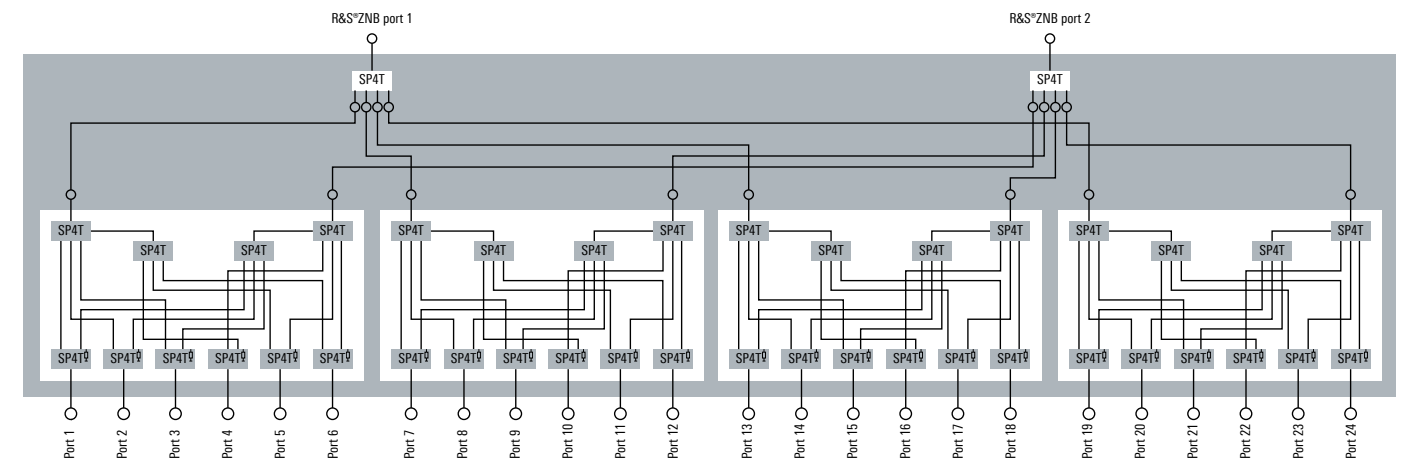



# A WORTHWHILE INVESTMENT

## Ready for the future

Industrial network analyzers have a useful life of ten years or more, depending on the application. Measurement tasks often change during this time.

The R&S®ZNB has a modular design, i.e. subassemblies such as DC inputs, GPIB interface, power supply, controller and hard disk are inserted into slots on the rear.

The R&S®ZNB can be quickly upgraded for new measurement tasks. Keeping the R&S®ZNB up to date, such as by installing a more powerful, next generation controller or adding new functionality, involves only minimum downtime and service cost.

## Upgrading test systems without rewriting system software

Network analyzers are the core of many test systems, for example in RF component production. Using latest generation Rohde&Schwarz network analyzers, system performance can be significantly enhanced.

The R&S®ZNB supports the remote control command sets of practically all other Rohde&Schwarz network analyzers as well as those of other manufacturers' instruments. Replacing an obsolete analyzer with an R&S®ZNB therefore poses no problems. In most cases it is sufficient to verify the response of the R&S®ZNB during a measurement sequence; there is no need for costly modifications in the system software.

## An analyzer that speaks the user's language

Many tasks are easiest solved in one's native language; the R&S®ZNB therefore comes with a multilingual user interface. Currently available languages include English, French, Spanish, Russian, Chinese and Japanese.

Soft panel menus for selecting language (left) and remote control command set (right).

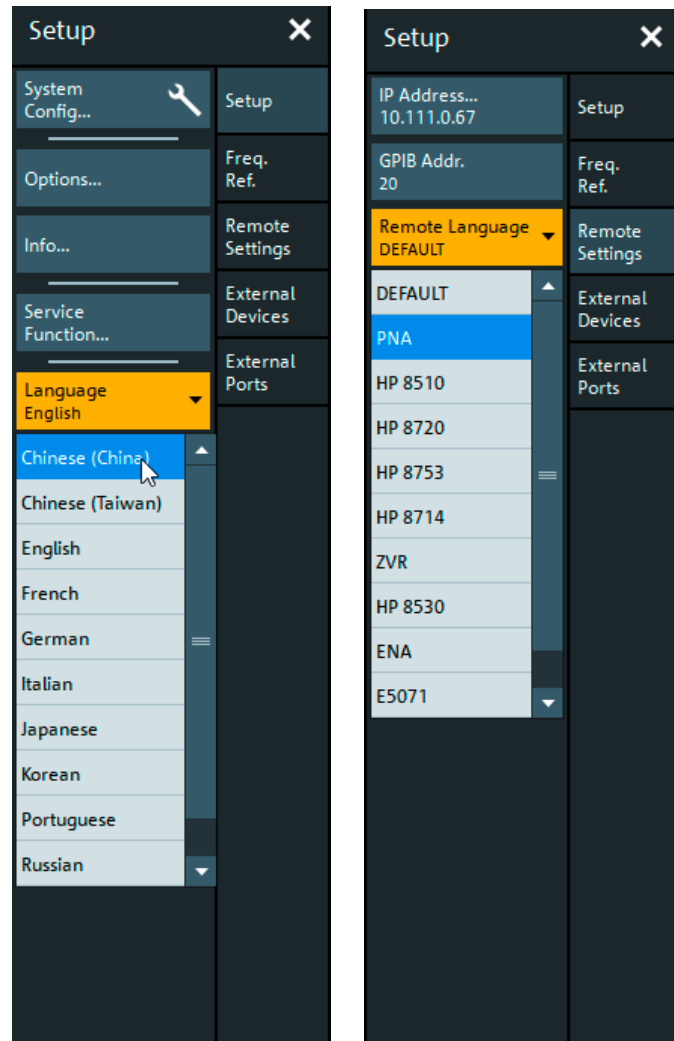

# ORDERING INFORMATION

Designation	Type	Frequency range	Order No.
<b>Base units</b>			
Vector network analyzer, 2 ports, 4.5 GHz, type N	R&S®ZNB4	9 kHz to 4.5 GHz	1334.3330.22
Vector network analyzer, 4 ports, 4.5 GHz, type N	R&S®ZNB4	9 kHz to 4.5 GHz	1334.3330.24
Vector network analyzer, 2 ports, 8.5 GHz, type N	R&S®ZNB8	9 kHz to 8.5 GHz	1334.3330.42
Vector network analyzer, 4 ports, 8.5 GHz, type N	R&S®ZNB8	9 kHz to 8.5 GHz	1334.3330.44
Vector network analyzer, 2 ports, 20 GHz, 3.5 mm	R&S®ZNB20	100 kHz to 20 GHz	1334.3330.62
Vector network analyzer, 4 ports, 20 GHz, 3.5 mm	R&S®ZNB20	100 kHz to 20 GHz	1334.3330.64
<b>Options</b>			
Bias tees for 2-port R&S®ZNB4/R&S®ZNB8	R&S®ZNB-B1	100 kHz to 4.5/8.5 GHz	1316.1700.02
Bias tees for 4-port R&S®ZNB4/R&S®ZNB8	R&S®ZNB-B1	100 kHz to 4.5/8.5 GHz	1316.1700.04
Receiver step attenuator, port 1, for R&S®ZNB4	R&S®ZNB4-B31	9 kHz to 4.5 GHz	1316.0185.02
Receiver step attenuator, port 2, for R&S®ZNB4	R&S®ZNB4-B32	9 kHz to 4.5 GHz	1316.0179.02
Receiver step attenuator, port 3, for R&S®ZNB4	R&S®ZNB4-B33	9 kHz to 4.5 GHz	1316.0262.02
Receiver step attenuator, port 4, for R&S®ZNB4	R&S®ZNB4-B34	9 kHz to 4.5 GHz	1316.0433.02
Extended power range for 2-port R&S®ZNB4	R&S®ZNB4-B22	9 kHz to 4.5 GHz	1316.0210.02
Extended power range for 4-port R&S®ZNB4	R&S®ZNB4-B24	9 kHz to 4.5 GHz	1316.0233.02
Extended dynamic range for 2-port R&S®ZNB4 <sup>1)</sup>	R&S®ZNB4-B52	9 kHz to 4.5 GHz	1319.4975.02
Extended dynamic range for 4-port R&S®ZNB4 <sup>1)</sup>	R&S®ZNB4-B54	9 kHz to 4.5 GHz	1319.4981.02
Receiver step attenuator, port 1, for R&S®ZNB8	R&S®ZNB8-B31	9 kHz to 8.5 GHz	1316.0191.02
Receiver step attenuator, port 2, for R&S®ZNB8	R&S®ZNB8-B32	9 kHz to 8.5 GHz	1316.0204.02
Receiver step attenuator, port 3, for R&S®ZNB8	R&S®ZNB8-B33	9 kHz to 8.5 GHz	1316.0162.02
Receiver step attenuator, port 4, for R&S®ZNB8	R&S®ZNB8-B34	9 kHz to 8.5 GHz	1316.0440.02
Extended power range for 2-port R&S®ZNB8	R&S®ZNB8-B22	9 kHz to 8.5 GHz	1316.0227.02
Extended power range for 4-port R&S®ZNB8	R&S®ZNB8-B24	9 kHz to 8.5 GHz	1316.0240.02
Extended dynamic range for 2-port R&S®ZNB8 <sup>1)</sup>	R&S®ZNB8-B52	9 kHz to 8.5 GHz	1319.4998.02
Extended dynamic range for 4-port R&S®ZNB8 <sup>1)</sup>	R&S®ZNB8-B54	9 kHz to 8.5 GHz	1319.5007.02
Extended power range for 2-port R&S®ZNB20	R&S®ZNB20-B22	100 kHz to 20 GHz	1317.8950.02
Extended power range for 4-port R&S®ZNB20	R&S®ZNB20-B24	100 kHz to 20 GHz	1317.8967.02
2nd internal source for R&S®ZNB4/R&S®ZNB8 <sup>2)</sup>	R&S®ZNB-B2	9 kHz to 8.5 GHz	1317.7954.02
2nd internal source for R&S®ZNB20 <sup>2)</sup>	R&S®ZNB20-B2	100 kHz to 20 GHz	1317.8980.02
Precision frequency reference	R&S®ZNB-B4		1316.1769.02
GPIB interface	R&S®ZNB-B10		1311.5995.04
Device control <sup>3)</sup>	R&S®ZNB-B12		1319.5088.02
Direct control cable <sup>3)</sup>	R&S®ZN-B121		1323.9290.00
Handler I/O (universal interface)	R&S®ZN-B14		1316.2459.05
External RFFE GPIO interface	R&S®ZN-Z15		1325.5905.02
External RFFE GPIO interface, including current and voltage measurements	R&S®ZN-Z15		1325.5905.03
DC inputs	R&S®ZNB-B81		1316.0004.02
Time domain analysis	R&S®ZNB-K2		1316.0156.02
Extended time domain analysis <sup>4)</sup>	R&S®ZNB-K20		1326.8072.02
Distance to fault	R&S®ZNB-K3		1350.5057.02
Frequency conversion <sup>5)</sup>	R&S®ZNB-K4		1316.2994.02
Intermodulation measurements <sup>6)</sup>	R&S®ZNB-K14		1317.8373.02
10 MHz receiver bandwidth	R&S®ZNB-K17		1316.1881.02
1 mHz frequency resolution	R&S®ZNB-K19		1317.8573.02

<sup>1)</sup> Cannot be combined with R&S®ZNB-B1 or R&S®ZNB4-B3x/R&S®ZNB8-B3x.

<sup>2)</sup> Requires R&S®ZNB 4-port model.

<sup>3)</sup> Required for direct control of R&S®ZN-Z84/R&S®ZN-Z85 switch matrix and R&S®ZN-Z15 external RFFE GPIO interface.

<sup>4)</sup> Requires R&S®ZNB-K2.

<sup>5)</sup> Requires R&S®ZVAB-B44 for control of external sources via the IEC/IEEE bus.

<sup>6)</sup> Requires R&S®ZNB-K4.

Designation	Type	Frequency range	Order No.
USB-to-IEC/IEEE adapter	R&S®ZVAB-B44		1302.5544.02
Real-time measurement uncertainty analysis	R&S®ZNB-K50		3644.5977.02
Real-time measurement uncertainty analysis, preinstalled	R&S®ZNB-K50P		1338.1810.02
Easy deembedding	R&S®ZNB-K210		1328.8592.02
In-situ deembedding	R&S®ZNB-K220		1328.8605.02
Smart fixture deembedding	R&S®ZNB-K230		1328.8611.02
Delta-L PCB characterization	R&S®ZNB-K231		1328.8628.02

#### Accessories

##### Calibration kits (manual calibration)

Calibration kit, N, 50 Ω	R&S®ZCAN	0 Hz to 3 GHz	0800.8515.52
Calibration kit, 3.5 mm (m)	R&S®ZN-Z135	0 Hz to 26.5 GHz	1328.8157.02
Calibration kit, 3.5 mm (f)	R&S®ZN-Z135	0 Hz to 26.5 GHz	1328.8157.03
Calibration kit, N (m)	R&S®ZN-Z170	0 Hz to 18 GHz	1328.8163.02
Calibration kit, N (f)	R&S®ZN-Z170	0 Hz to 18 GHz	1328.8163.03
Calibration kit, N, 50 Ω	R&S®ZV-Z270	0 Hz to 18 GHz	5011.6536.02
Calibration kit, 3.5 mm	R&S®ZN-Z235	0 Hz to 26.5 GHz	1336.8500.02

##### Calibration units (automatic calibration)

Calibration unit, 2 ports, SMA (f)	R&S®ZN-Z151	100 kHz to 8.5 GHz	1317.9134.32
Calibration unit, 2 ports, N (f)	R&S®ZN-Z151	100 kHz to 8.5 GHz	1317.9134.72
Calibration unit, 6 ports, SMA (f)	R&S®ZN-Z152	100 kHz to 8.5 GHz	1319.6003.36
Calibration unit, 4 ports, SMA (f)	R&S®ZN-Z153	100 kHz to 8.5 GHz	1319.6178.34
Calibration unit, 6 ports, SMA (f)	R&S®ZN-Z154	100 kHz to 8.5 GHz	1319.5120.02
Additional ports 7 to 12, SMA (f)	R&S®ZNZ154-B22	100 kHz to 8.5 GHz	1319.5136.22
Additional ports 13 to 18, SMA (f)	R&S®ZNZ154-B32	100 kHz to 8.5 GHz	1319.5136.32
Additional ports 19 to 24, SMA (f)	R&S®ZNZ154-B42	100 kHz to 8.5 GHz	1319.5136.42
Calibration unit, 2 ports, 3.5 mm (f)	R&S®ZN-Z50	9 kHz to 9 GHz	1335.6904.30
Calibration unit, 2 ports, 3.5 mm (f)	R&S®ZN-Z50	9 kHz to 26.5 GHz	1335.6904.32
Calibration unit, 2 ports, 3.5 mm (f)	R&S®ZN-Z51	100 kHz to 8.5 GHz	1319.5507.32
Calibration unit, 4 ports, 3.5 mm (f)	R&S®ZN-Z51	100 kHz to 8.5 GHz	1319.5507.34
Calibration unit, 2 ports, N (f) <sup>7)</sup>	R&S®ZN-Z51	100 kHz to 8.5 GHz	1319.5507.72
Calibration unit, 4 ports, N (f) <sup>7)</sup>	R&S®ZN-Z51	100 kHz to 8.5 GHz	1319.5507.74
Calibration unit, 4 ports, 3.5 mm (f)	R&S®ZN-Z52	100 kHz to 26.5 GHz	1335.6991.30
Calibration unit, 2 ports, 3.5 mm (f)	R&S®ZN-Z53	100 kHz to 26.5 GHz	1335.7046.32
Calibration unit, 2 ports, N (f)	R&S®ZN-Z53	100 kHz to 18 GHz	1335.7046.72
Calibration unit, 8 ports, N (f)	R&S®ZV-Z58	300 kHz to 8 GHz	1164.0638.78
Calibration unit, 6 ports, 3.5 mm (f)	R&S®ZV-Z59	10 MHz to 20 GHz	1164.0450.36

##### Switch matrices

Switch matrix, 8.5 GHz, 2 VNA ports to 6 test ports, base unit, SMA (f) <sup>9)</sup>	R&S®ZN-Z84	10 MHz to 8.5 GHz	1319.4500.02
Additional test ports 7 to 12, 4 VNA ports <sup>9)</sup>	R&S®ZN-Z84-B24	10 MHz to 8.5 GHz	1319.4969.24
Additional test ports 7 to 12, 2 VNA ports <sup>9)</sup>	R&S®ZN-Z84-B22	10 MHz to 8.5 GHz	1319.4969.22
Additional test ports 13 to 18, 4 VNA ports <sup>10)</sup>	R&S®ZN-Z84-B34	10 MHz to 8.5 GHz	1319.4969.34
Additional test ports 13 to 18, 2 VNA ports <sup>10)</sup>	R&S®ZN-Z84-B32	10 MHz to 8.5 GHz	1319.4969.32
Additional test ports 19 to 24, 4 VNA ports <sup>11)</sup>	R&S®ZN-Z84-B44	10 MHz to 8.5 GHz	1319.4969.44
Additional test ports 19 to 24, 2 VNA ports <sup>11)</sup>	R&S®ZN-Z84-B42	10 MHz to 8.5 GHz	1319.4969.42
Switch matrix, 20 GHz, 2 VNA ports to 6 test ports, base unit, SMA (f) <sup>12)</sup>	R&S®ZN-Z85	10 MHz to 20 GHz	1326.4777.03
Additional test ports 7 to 12, 4 VNA ports <sup>13)</sup>	R&S®ZN-Z85-B24	10 MHz to 20 GHz	1326.4831.26

Designation	Type	Frequency range	Order No.
<b>Test cables</b>			
N (m)/N (m), 50 Ω, length: 0.6 m/1 m	R&S®ZV-Z91	0 Hz to 18 GHz	1301.7572.25/.38
N (m)/N (m), 50 Ω, length: 0.6 m/0.9 m	R&S®ZV-Z191	0 Hz to 18 GHz	1306.4507.24/.36
N (m)/3.5 mm (m), 50 Ω, length: 0.6 m/1 m	R&S®ZV-Z92	0 Hz to 18 GHz	1301.7589.25/.38
N (m)/3.5 mm (m), 50 Ω, length: 0.6 m/0.9 m	R&S®ZV-Z192	0 Hz to 18 GHz	1306.4513.24/.36
3.5 mm (f)/3.5 mm (m), length: 0.6 m/1 m	R&S®ZV-Z93	0 Hz to 26.5 GHz	1301.7595.25/.38
3.5 mm (f)/3.5 mm (m), length: 0.6 m/0.9 m/1.5 m	R&S®ZV-Z193	0 Hz to 26.5 GHz	1306.4520.24/.36/.60

#### Hardware add-ons

19" rackmount kit, 2 RU (e.g. for R&S®ZN-Z84)	R&S®ZZA-KN2		1175.3010.00
19" rackmount kit, 5 RU (e.g. for R&S®ZNB)	R&S®ZZA-KN5		1175.3040.00
RF cable set, N (m)/3.5 mm (m), for connecting two 2 × n-port R&S®ZN-Z84 switch matrices to a 4-port R&S®ZNB4 or R&S®ZNB8	R&S®ZN-Z28	10 MHz to 8.5 GHz	1326.6605.02
Additional removable SSD, 512 Gbyte, Windows 10	R&S®ZNB-B19		1334.3860.03

#### VNA simulation

License dongle	R&S®ZNPC		1325.6601.02
Simulation of R&S®ZNB, R&S®ZNB4, R&S®ZNC, R&S®ZND <sup>14)</sup>	R&S®ZNXSIM-K1		1334.4066.02
TDR for VNA simulation <sup>15)</sup>	R&S®ZNXSIM-K22		1338.1632.02

<sup>7)</sup> Can be configured ex factory with N (m/f), 3.5 mm (m/f), 7/16 (m/f) (see R&S®ZN-Z51 data sheet, PD 3606.8995.22).

<sup>8)</sup> Includes cables for connecting an R&S®ZN-Z84 switch matrix to an R&S®ZNB4/R&S®ZNB8 analyzer.

<sup>9)</sup> Requires R&S®ZN-Z84.

<sup>10)</sup> Requires R&S®ZN-Z84-B2x.

<sup>11)</sup> Requires R&S®ZN-Z84-B3x.

<sup>12)</sup> Includes cables for connecting an R&S®ZN-Z85 switch matrix to an R&S®ZNB20 analyzer.

<sup>13)</sup> Requires R&S®ZN-Z85.

<sup>14)</sup> Requires R&S®ZNPC.

<sup>15)</sup> Requires R&S®ZNXSIM-K1.

#### Warranty

Base unit	3 years
All other items <sup>1)</sup>	1 year

#### Options

Extended warranty, one year	R&S®WE1	Please contact your local Rohde & Schwarz sales office.
Extended warranty, two years	R&S®WE2	
Extended warranty with calibration coverage, one year	R&S®CW1	
Extended warranty with calibration coverage, two years	R&S®CW2	
Extended warranty with accredited calibration coverage, one year	R&S®AW1	
Extended warranty with accredited calibration coverage, two years	R&S®AW2	

<sup>1)</sup> For options that are installed, the remaining base unit warranty applies if longer than 1 year. Exception: all batteries have a 1 year warranty.

For further information about the R&S®ZNB40, see product brochure (PD 5214.5384.12) and data sheet (PD 5214.5384.22).

Your local Rohde & Schwarz expert will help you determine the optimum solution for your requirements. To find your nearest Rohde & Schwarz representative, visit [www.sales.rohde-schwarz.com](http://www.sales.rohde-schwarz.com)



## Service that adds value

- ▶ Worldwide
- ▶ Local and personalized
- ▶ Customized and flexible
- ▶ Uncompromising quality
- ▶ Long-term dependability

## Rohde & Schwarz

The Rohde & Schwarz electronics group offers innovative solutions in the following business fields: test and measurement, broadcast and media, secure communications, cybersecurity, monitoring and network testing. Founded more than 80 years ago, the independent company which is headquartered in Munich, Germany, has an extensive sales and service network with locations in more than 70 countries.

[www.rohde-schwarz.com](http://www.rohde-schwarz.com)

## Sustainable product design

- ▶ Environmental compatibility and eco-footprint
- ▶ Energy efficiency and low emissions
- ▶ Longevity and optimized total cost of ownership

Certified Quality Management  
**ISO 9001**

Certified Environmental Management  
**ISO 14001**

## Rohde & Schwarz training

[www.training.rohde-schwarz.com](http://www.training.rohde-schwarz.com)

## Rohde & Schwarz customer support

[www.rohde-schwarz.com/support](http://www.rohde-schwarz.com/support)

