

R&S®ZND

Vector Network Analyzers User Manual

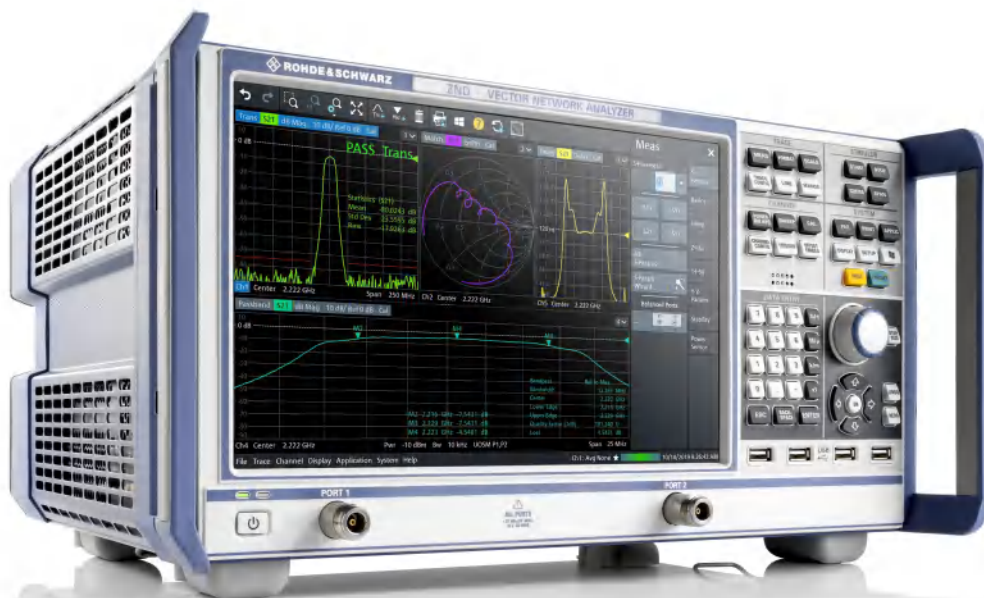

1173955702
Version 59

ROHDE & SCHWARZ
Make ideas real



This manual describes the R&S®ZND (2 ports, 9 kHz to 4.5 GHz, unidirectional, N connectors), order no. 1328.5170.92 and its options.

Hardware Options

- R&S®ZND-B7 "High Output Power", order no. 1338.1578.02
- R&S®ZND-B10 "GPIB Interface", order no. 1328.5358.02
- R&S®ZND-B14 "Handler I/O", order no. 1316.2459.05
- R&S®ZND-B19 "Additional Removable Harddisc", order no. 1326.7760.02
- R&S®ZND-B19 "Additional Removable SSD", order no. 1338.1703.02

Software Options

- R&S®ZND-K1 "Frequency range extension to 8.5 GHz for unidirectional instrument", order no. 1328.5306.02
(not compatible with R&S®ZND-K5 and R&S®ZND-K8)
- R&S®ZND-K2 "Time Domain (TDR)", order no. 1328.5393.02
- R&S®ZND-K3 "Distance to Fault (DTF)", order no. 1328.5393.02
- R&S®ZND-K5 "Bidirectional measurements 9 kHz to 4.5 GHz", order no. 1328.5312.02
(not compatible with R&S®ZND-K1 and R&S®ZND-K6)
- R&S®ZND-K6 "Bidirectional measurements 9 kHz to 8.5 GHz", order no. 1328.5329.02
(requires R&S®ZND-K1; not compatible with R&S®ZND-K5 and R&S®ZND-K8)
- R&S®ZND-K8 "Frequency range extension to 8.5 GHz for bidirectional instrument", order no. 1328.5412.02
(requires R&S®ZND-K5; not compatible with R&S®ZND-K1 and R&S®ZND-K6)
- R&S®ZND-K7 "Extended Power Range", order no. 1328.5335.02
- R&S®ZND-K19 "1 mHz Frequency Resolution", order no. 1326.8089.02
- R&S®ZND-K210 "EAZY De-embedding (EZD) based on IEEE 370", order no. 1328.8670.02
- R&S®ZND-K220 "In-Situ De-embedding (ISD) that covers IEEE 370", order no. 1328.8686.02
- R&S®ZND-K230 "Smart Fixture De-embedding (SFD)", order no. 1328.8692.02
- R&S®ZND-K231 "Delta-L 4.0 PCB characterization", order no. 1328.8705.02

© 2021 Rohde & Schwarz GmbH & Co. KG

Mühlhofstr. 15, 81671 München, Germany

Phone: +49 89 41 29 - 0

Email: info@rohde-schwarz.com

Internet: www.rohde-schwarz.com

Subject to change – data without tolerance limits is not binding.

R&S® is a registered trademark of Rohde & Schwarz GmbH & Co. KG.

Trade names are trademarks of the owners.

1173.9557.02 | Version 59 | R&S®ZND

Throughout this manual, R&S® is abbreviated as R&S.

Contents

1	Preface	13
1.1	Documentation Overview	13
1.1.1	Getting Started Manual.....	13
1.1.2	User Manual and Help.....	13
1.1.3	Service Manual.....	13
1.1.4	Instrument Security Procedures.....	14
1.1.5	Basic Safety Instructions.....	14
1.1.6	Data Sheets and Brochures.....	14
1.1.7	Release Notes and Open Source Acknowledgment (OSA).....	14
1.1.8	Application Notes, Application Cards, White Papers, etc.....	14
1.2	Conventions Used in the Documentation	15
1.2.1	Typographical Conventions.....	15
1.2.2	Conventions for Procedure Descriptions.....	15
1.2.3	Notes on Screenshots.....	15
2	Safety Information	16
3	What's New in Firmware V3.30	17
4	Getting Started	20
4.1	Putting the Analyzer into Operation	20
4.1.1	Unpacking and Checking the Instrument.....	20
4.1.2	Positioning the Instrument.....	21
4.1.3	Bench Top Operation.....	21
4.1.4	Operation in a 19" Rack.....	22
4.1.5	EMI Suppression.....	22
4.1.6	Connecting the Analyzer to the AC Supply.....	23
4.1.7	Starting the Analyzer and Shutting Down.....	23
4.1.8	Standby and Ready State.....	24
4.1.9	Connecting External Accessories.....	24
4.1.10	Minimizing the VNA Application.....	27
4.2	Instrument Tour	28
4.2.1	Front Panel.....	28

4.2.2	Rear Panel.....	34
4.3	Operating the Instrument.....	35
4.3.1	Manual Operation.....	36
4.3.2	Control Elements of the Application Window.....	40
4.3.3	Working with Dialogs.....	46
4.3.4	Handling Diagrams, Traces, and Markers.....	47
4.3.5	Entering Data.....	51
4.3.6	Scaling Diagrams.....	54
4.4	Performing Measurements.....	60
4.4.1	Transmission S-Parameter Measurement.....	60
4.4.2	Reflection S-Parameter Measurement.....	67
5	Concepts and Features.....	69
5.1	Basic Concepts.....	69
5.1.1	Global (Persistent) Settings.....	69
5.1.2	Recall Sets.....	70
5.1.3	Traces, Channels and Diagrams.....	70
5.1.4	Sweep Control.....	72
5.1.5	Data Flow.....	77
5.2	Screen Elements.....	81
5.2.1	Display Elements of a Diagram.....	81
5.2.2	Dialogs.....	92
5.2.3	Trace Formats.....	95
5.3	Measurement Results.....	103
5.3.1	S-Parameters.....	104
5.3.2	Reference Impedances.....	105
5.3.3	Impedance Parameters.....	107
5.3.4	Admittance Parameters.....	111
5.3.5	Wave Quantities and Ratios.....	112
5.3.6	Unbalance-Balance Conversion.....	115
5.3.7	Stability Factors.....	120
5.3.8	Delay, Aperture, Electrical Length.....	121
5.4	Operations on Traces.....	122
5.4.1	Limit Check.....	122

5.4.2	Trace Files.....	129
5.4.3	Memory-Mapped Trace Data Transfer.....	138
5.5	Calibration.....	140
5.5.1	Calibration Types.....	141
5.5.2	Calibration Standards and Calibration Kits.....	152
5.5.3	Calibration Pool.....	158
5.5.4	Calibration Labels.....	158
5.5.5	Automatic Calibration.....	159
5.5.6	Scalar Power Calibration.....	167
5.5.7	Parallel Calibration of Multiple Channels.....	172
5.6	Offset Parameters and De-/Embedding.....	173
5.6.1	Offset Parameters.....	173
5.6.2	Embedding and Deembedding.....	179
5.7	Optional Extensions and Accessories.....	191
5.7.1	Frequency Range Extension to 8.5 GHz for unidirectional R&S ZND.....	192
5.7.2	Bidirectional Measurements 100 kHz to 4.5 GHz for R&S ZND.....	192
5.7.3	Bidirectional Measurements 100 kHz to 8.5 GHz for R&S ZND.....	192
5.7.4	Frequency Range Extension to 8.5 GHz for bidirectional R&S ZND.....	192
5.7.5	Time Domain Analysis.....	193
5.7.6	Distance-to-Fault Measurements.....	200
5.7.7	Frequency Resolution 1 mHz.....	202
5.7.8	Eazy De-embedding Based on IEEE 370.....	202
5.7.9	In-situ De-Embedding.....	204
5.7.10	Smart Fixture De-Embedding.....	204
5.7.11	Delta-L 4.0 PCB Characterization.....	204
5.7.12	Health and Usage Monitoring Service (HUMS).....	205
5.7.13	High Output Power for R&S ZND.....	206
5.7.14	GPIB Interface.....	207
5.7.15	Handler I/O (Universal Interface).....	207
5.7.16	Additional Removable System Drive.....	207
5.7.17	Extended Power Range.....	207
5.7.18	USB-to-IEC/IEEE Adapter.....	208
5.7.19	External Power Meters.....	208

5.7.20	External Switch Matrices.....	210
5.7.21	External DLLs.....	216
6	GUI Reference.....	219
6.1	Function Keys and Softtools.....	219
6.2	Meas Softtool.....	221
6.2.1	S-Params Tab.....	222
6.2.2	Ratios Tab.....	231
6.2.3	Wave Tab.....	234
6.2.4	Z←Sij Tab.....	237
6.2.5	Y←Sij Tab.....	239
6.2.6	Y-Z-Params Tab.....	241
6.2.7	Imbal. CMRR Tab.....	243
6.2.8	Stability Tab.....	246
6.2.9	Power Sensor Tab.....	247
6.2.10	External DLL Tab.....	248
6.3	Format Softtool.....	252
6.4	Scale Softtool.....	259
6.4.1	Scale Values Tab.....	259
6.4.2	Scale Coupling Tab.....	262
6.4.3	Zoom Tab.....	262
6.5	Trace Config Softtool.....	264
6.5.1	Traces Tab.....	264
6.5.2	Mem.....	269
6.5.3	All Mem All Data Tab.....	272
6.5.4	Math Tab.....	273
6.5.5	Time Domain Tab.....	279
6.5.6	Time Gate Tab.....	284
6.5.7	Distance to Fault Tab.....	286
6.5.8	Trace Statistics Tab.....	286
6.5.9	Smooth Shift Hold Tab.....	292
6.5.10	Infinite Averaging Tab.....	295
6.5.11	Trace Data Tab.....	296
6.6	Lines Softtool.....	304

6.6.1	Limit Test Tab.....	304
6.6.2	Ripple Test Tab.....	313
6.6.3	Circle Test Tab.....	317
6.6.4	Display Circle Tab.....	321
6.6.5	Horiz. Line Tab.....	322
6.7	Marker Softtool.....	323
6.7.1	Markers Tab.....	323
6.7.2	Marker Props Tab.....	326
6.7.3	Marker Search Tab.....	328
6.7.4	Multiple Peak Tab.....	333
6.7.5	Target Search Tab.....	335
6.7.6	Bandfilter Tab.....	337
6.7.7	Set by Marker Tab.....	341
6.7.8	Info Field Tab.....	343
6.7.9	Marker Coupling Tab.....	343
6.8	Stimulus Softtool.....	345
6.8.1	Stimulus Tab.....	345
6.8.2	Power Tab.....	346
6.8.3	Time Domain X-Axis Tab.....	347
6.9	Power Bw Avg Softtool.....	349
6.9.1	Power Tab.....	349
6.9.2	Bandwidth Tab.....	349
6.9.3	Average Tab.....	350
6.10	Sweep Softtool.....	352
6.10.1	Sweep Params Tab.....	352
6.10.2	Sweep Type Tab.....	355
6.10.3	Trigger Tab.....	365
6.10.4	Sweep Control Tab.....	370
6.11	Cal Softtool.....	374
6.11.1	Start Cal Tab.....	374
6.11.2	Cal Devices Tab.....	400
6.11.3	Pwr Cal Settings Tab.....	414
6.11.4	Use Cal Tab.....	421

6.12 Channel Config Softtool.....	426
6.12.1 Channels Tab.....	426
6.12.2 Port Config Tab.....	430
6.12.3 Mode Tab.....	432
6.12.4 Pwr Cal Settings Tab.....	434
6.13 Offset Embed Softtool.....	434
6.13.1 Offset Embed Dock Widget.....	434
6.13.2 Offset Tab.....	443
6.13.3 One Way Loss Tab.....	449
6.13.4 Single Ended Tab.....	451
6.13.5 Fixture Modeling Dialog.....	454
6.13.6 Port Sets Tab.....	467
6.13.7 Balanced Tab.....	469
6.13.8 Ground Loop Tab.....	472
6.13.9 Differential Match Tab.....	474
6.13.10 Config Tab.....	476
6.13.11 Delta-L Tab.....	477
6.14 File Softtool.....	484
6.14.1 Recall Sets Tab.....	485
6.14.2 Favorites Tab.....	489
6.14.3 Print Tab.....	490
6.14.4 Printer Setup Dialog.....	491
6.14.5 Trace Data Tab.....	492
6.14.6 More Tab.....	493
6.15 Applic Softtool.....	493
6.15.1 External Tools Application.....	493
6.15.2 Distance to Fault Application.....	495
6.16 Display Softtool.....	503
6.16.1 Diagram Tab.....	503
6.16.2 Split Tab.....	506
6.16.3 Config Tab.....	509
6.16.4 View Bar Tab.....	516
6.16.5 Touchscreen Tab.....	517

6.17 Setup Softtool.....	517
6.17.1 Setup Tab.....	518
6.17.2 Freq. Ref. Tab.....	538
6.17.3 Remote Settings Tab.....	539
6.17.4 External Devices Tab.....	541
6.17.5 External Ports Tab.....	547
6.18 Help Softtool.....	556
6.19 Additional Function Keys.....	557
7 Remote Control.....	559
7.1 Introduction to Remote Control.....	559
7.1.1 Starting a Remote Control Session.....	560
7.1.2 GPIB Explorer.....	560
7.1.3 Switchover to Remote Control.....	562
7.1.4 Combining Manual and Remote Control.....	565
7.2 Messages.....	565
7.2.1 Device Messages (Commands and Device Responses).....	565
7.2.2 SCPI Command Structure and Syntax.....	566
7.2.3 SCPI Parameters.....	569
7.3 Basic Remote Control Concepts.....	572
7.3.1 Traces, Channels, and Diagram Areas.....	572
7.3.2 Active Traces in Remote Control.....	573
7.3.3 Initiating Measurements, Speed Considerations.....	574
7.3.4 Addressing Traces and Channels.....	575
7.4 Command Processing.....	576
7.4.1 Input Unit.....	576
7.4.2 Command Recognition.....	577
7.4.3 Data Base and Instrument Hardware.....	577
7.4.4 Status Reporting System.....	578
7.4.5 Output Unit.....	578
7.4.6 Command Sequence and Command Synchronization.....	578
7.5 Status Reporting System.....	580
7.5.1 Overview of Status Registers.....	581
7.5.2 Structure of a SCPI Status Register.....	581

7.5.3	Contents of the Status Registers.....	583
7.5.4	Application of the Status Reporting System.....	589
7.5.5	Reset Values of the Status Reporting System.....	592
8	Command Reference.....	594
8.1	Special Terms and Notation.....	594
8.1.1	Upper/Lower Case.....	595
8.1.2	Special Characters.....	595
8.1.3	Parameters.....	595
8.1.4	Numeric Suffixes.....	595
8.2	Common Commands.....	596
8.3	SCPI Command Reference.....	597
8.3.1	CALCulate Commands.....	598
8.3.2	CONFigure Commands.....	783
8.3.3	CONTrol Commands.....	791
8.3.4	DIAGnostic Commands.....	800
8.3.5	DISPlay Commands.....	802
8.3.6	FORMat Commands.....	828
8.3.7	HCOPy Commands.....	830
8.3.8	INITiate Commands.....	835
8.3.9	INSTrument Commands.....	838
8.3.10	MEMory.....	839
8.3.11	MMEMory Commands.....	841
8.3.12	OUTPut Commands.....	878
8.3.13	PROGram Commands.....	883
8.3.14	[SENSe:] Commands.....	886
8.3.15	SOURce Commands.....	989
8.3.16	STATus Commands.....	1015
8.3.17	SYSTem Commands.....	1018
8.3.18	TRACe Commands.....	1057
8.3.19	TRIGger Commands.....	1060
8.4	HUMS and Service Date Commands.....	1067
8.4.1	SNMP/REST commands.....	1068
8.4.2	System Information Commands.....	1071

8.4.3	Device tags commands.....	1081
8.4.4	Utilization commands.....	1082
8.4.5	Service date commands.....	1085
8.5	R&S ZVR/ZVABT Compatible Commands.....	1087
9	Programming Examples.....	1110
9.1	Basic Tasks.....	1110
9.1.1	Typical Stages of a Remote Control Program.....	1110
9.1.2	Channel, Trace and Diagram Handling.....	1113
9.2	Condensed Programming Examples.....	1119
9.2.1	Path Independent RC Programs.....	1120
9.2.2	Trace and Diagram Handling.....	1120
9.2.3	Using Markers.....	1129
9.2.4	Data Handling.....	1131
9.2.5	Calibration.....	1135
9.2.6	Fixture Modeling.....	1141
10	Error Messages and Troubleshooting.....	1143
10.1	Errors during Firmware Operation.....	1143
10.1.1	Asynchronous Errors.....	1144
10.1.2	Errors during Measurement.....	1144
10.2	Errors during Firmware Installation/Update.....	1145
10.3	Collecting Information for Technical Support.....	1146
10.4	Contacting Customer Support.....	1148
11	Annexes.....	1149
11.1	Administrative Tasks.....	1149
11.1.1	Windows Operating System.....	1149
11.1.2	Firmware Installation.....	1150
11.1.3	Remote Operation in a LAN.....	1150
11.2	System Recovery.....	1155
11.3	Interfaces and Connectors.....	1155
11.3.1	Rear Panel Connectors.....	1155
11.3.2	LAN Interface.....	1157
11.3.3	GPIB Interface.....	1158

11.3.4	Handler I/O (Universal Interface).....	1161
11.4	Maintenance.....	1169
11.4.1	Cleaning.....	1170
11.4.2	Storing and Packing the Instrument.....	1170
11.5	Showroom Mode.....	1171
11.6	ENA Emulation Commands.....	1171
	Glossary: Frequently Used Terms.....	1179
	List of commands.....	1185
	Index.....	1206

1 Preface

This chapter provides safety-related information, an overview of the user documentation and the conventions used in the documentation.

1.1 Documentation Overview

This section provides an overview of the R&S ZND user documentation. Unless specified otherwise, you find the documents on the R&S ZND product page at:

- <https://www.rohde-schwarz.com/manual/ZND>

1.1.1 Getting Started Manual

Introduces the R&S ZND and describes how to set up and start working with the product. Includes basic operations, typical measurement examples, and general information, e.g. safety instructions, etc.

A printed version is delivered with the instrument. A PDF version is available for download on the Internet.

1.1.2 User Manual and Help

The user manual contains the description of all instrument modes and functions. It also provides an introduction to remote control, a complete description of the remote control commands with programming examples, and information on maintenance, instrument interfaces and error messages. Includes the contents of the getting started manual.

The contents of the user manual are available as help in the R&S ZND. The help offers quick, context-sensitive access to the complete information for the instrument and its firmware.

The user manual is also available for download or for immediate display on the Internet.

1.1.3 Service Manual

Describes the performance test for checking the rated specifications, module replacement and repair, firmware update, troubleshooting and fault elimination, and contains mechanical drawings and spare part lists.

The service manual is available for registered users on the global Rohde & Schwarz information system (GLORIS):

- [R&S ZND Service Manual](#)

1.1.4 Instrument Security Procedures

Deals with security issues when working with the R&S ZND in secure areas. It is available for download on the Internet.

1.1.5 Basic Safety Instructions

Contains safety instructions, operating conditions and further important information. The printed document is delivered with the instrument.

1.1.6 Data Sheets and Brochures

The data sheet contains the technical specifications of the R&S ZND. It also lists the firmware applications and their order numbers, and optional accessories.

The brochure provides an overview of the instrument and deals with the specific characteristics.

See

- <https://www.rohde-schwarz.com/brochure-datasheet/ZND>

1.1.7 Release Notes and Open Source Acknowledgment (OSA)

The release notes list new features, improvements and known issues of the current firmware version, and describe the firmware installation.

The open-source acknowledgment document provides verbatim license texts of the used open source software.

See

- <https://www.rohde-schwarz.com/firmware/ZND>

1.1.8 Application Notes, Application Cards, White Papers, etc.

These documents deal with special applications or background information on particular topics.

See

- <https://www.rohde-schwarz.com/application/ZND>

1.2 Conventions Used in the Documentation

1.2.1 Typographical Conventions

The following text markers are used throughout this documentation:

Convention	Description
[Keys]	Key and knob names are enclosed by square brackets.
"Graphical user interface elements"	All names of graphical user interface elements on the screen, such as dialog boxes, menus, options, buttons, and softkeys are enclosed by quotation marks.
File names, commands, program code	File names, commands, coding samples and screen output are distinguished by their font.
<i>Input</i>	Input to be entered by the user is displayed in italics.
Links	Links that you can click are displayed in blue font.
"References"	References to other parts of the documentation are enclosed by quotation marks.

1.2.2 Conventions for Procedure Descriptions

When operating the instrument, several alternative methods may be available to perform the same task. In this case, the procedure using the touchscreen is described. Any elements that can be activated by touching can also be clicked using an additionally connected mouse. The alternative procedure using the keys on the instrument or the on-screen keyboard is only described if it deviates from the standard operating procedures.

The term "select" may refer to any of the described methods, i.e. using a finger on the touchscreen, a mouse pointer in the display, or a key on the instrument or on a keyboard.

1.2.3 Notes on Screenshots

When describing the functions of the product, we use sample screenshots. These screenshots are meant to illustrate as many as possible of the provided functions and possible interdependencies between parameters. The shown values may not represent realistic usage scenarios.

The screenshots usually show a fully equipped product, that is: with all options installed. Thus, some functions shown in the screenshots may not be available in your particular product configuration.

2 Safety Information

The product documentation helps you use the R&S ZND safely and efficiently. Follow the instructions provided here and in the printed "Basic Safety Instructions". Keep the product documentation nearby and offer it to other users.

Intended use

The R&S ZND is intended for the development, production and verification of electronic components and devices in industrial, administrative, and laboratory environments. Use the R&S ZND only for its designated purpose. Observe the operating conditions and performance limits stated in the data sheet.

Where do I find safety information?

Safety information is part of the product documentation. It warns you about the potential dangers and gives instructions how to prevent personal injuries or damage caused by dangerous situations. Safety information is provided as follows:

- The printed "Basic Safety Instructions" provide safety information in many languages and are delivered with the R&S ZND.
- Throughout the documentation, safety instructions are provided when you need to take care during setup or operation.

3 What's New in Firmware V3.30

Version 3.30 of the R&S ZND firmware provides the following changes:

New functionality

- Cal validation: use a cal unit to check the accuracy of the active channel calibration
See [Chapter 5.5.5.4, "Calibration Validation"](#), on page 163
- New software option R&S ZND-K980: R&S HUMS (health and utilization monitoring service)
 - Persistent collection of health and utilization data
 - Configurable access via REST and SNMP interfaces
 See [Chapter 5.7.12, "Health and Usage Monitoring Service \(HUMS\)"](#), on page 205
- Plugin interface and SDK for custom DLLs: extend the VNA firmware by custom SW components
See [Chapter 5.7.21, "External DLLs"](#), on page 216
- New "Block Alternated" driving mode
See ["Block Alternated driving mode"](#) on page 74
- Source flatness calibration can now use the configured offset de-/embedding
See ["Embedding"](#) on page 416
- "Web Control": browser-based access to the VNA GUI via the instrument's web interface
- Unidirectional R&S ZND now supports automatic calibration (OSM at port 1, Trans Norm and One Path Two Ports with source port 1)

Modified functionality

- "Auto Power Reduction for Cal Unit" global calibration setting renamed to "Auto Power Setting for Cal Unit"
See ["Auto Power Setting for Cal Unit"](#) on page 521
- Delta-L (R&S ZND-K231):
GUI
 - The "Measurements" setting in the "Delta-L Settings" dialog now restricts the Delta-L measurements to ports of the selected type (single-ended or balanced).
 - Its previous functionality (switch between single-ended and differential mode of the 1-length method) is now provided by the "1L Diff. Mode" checkbox.
 See [Chapter 6.13.11.1, "Delta-L Settings Dialog"](#), on page 478
 The remote control interface was changed accordingly.
 - Existing command `CALCulate:FMODEL:DELT:MEASurement` now restricts the Delta-L measurements to balanced or single-ended ports:
 - New command `CALCulate:FMODEL:DELT:M1L:DIFFmode` to enable/disable the differential mode of the 1-length method:
- The integrated license server was updated to version 1.26.3.1500
Note for R&S ZNXSIM: if you want to use floating licenses, the floating license server must have at least this version

New remote control features

- ENA emulation command alias `[SENSe<Ch>]:SWEep:MODE`
- Pipelining of measurement data: new command `CALCulate:PIPeLining:DATA?` that queries the availability of channel results in single-sweep mode

Improvements

- The number of decimal places can now also be configured for *meter* values
See "[Decimal Places](#)" on page 524
- Trace data export: the number of decimal places of stimulus and response values can now be configured
See "[Decimal Places](#)" on page 300
- Easy De-embedding (R&S ZND-K210): support for impedance correction
See "[Impedance Corrected/Impedance Correction Settings](#)" on page 466
- Delta-L (R&S ZND-K231) measurements can now include the TDR impedance traces, if R&S ZND-K2 is installed
See "[Trace](#)" on page 480
- Disable/enable all deembedding functions with a single tap or click
See "[All Deembedding Activated](#)" on page 452
- ISD tool (self-installed or with option [Chapter 5.7.10, "Smart Fixture De-Embedding"](#), on page 204): support of "Small Fixture" mode
See [Chapter 6.13.5.6, "ISD Advanced Settings"](#), on page 461
- Distance to Fault measurements (R&S ZND-K3): cable type attenuations can be defined for frequencies > 6 GHz

Solved issues

- Changing the average factor was ignored while averaging was active
- Limit line check: PASS/FAIL info field disappeared when diagram was maximized
- Printing with user-defined colors did not work as expected
- Command `SENSe<Ch>:SWEep:TYPE POINT` did not always switch from segmented to CW sweep mode
- LAN power sensors R&S NRP18SN and R&S NRP18AN were not detected correctly
- Switch matrix operation: if multiple matrix switch positions are needed, the external "Channel (Sweep)" trigger required one trigger signal per matrix position instead of one trigger signal per channel
- Formula-defined limit lines were not exported to limit line files (*.limit)
- "Repeat Cal" remained enabled after incompatible changes of the swept frequencies
- Markers on traces whose value at the marker position was above or below the visible range, were not displayed
- Automatic calibration: changing the port assignment to non-default or after auto-detection did not work and caused an exception
- No VXI-11 connectivity after upgrade from FW V2.xx to FW V3.yy

Firmware version

- ▶ To check your R&S ZND firmware version, select "Help" > "About..." from the main menu.

4 Getting Started

4.1 Putting the Analyzer into Operation

This section describes the basic steps to be taken when setting up the analyzer for the first time.

Simple measurement examples are provided in [Chapter 4.4, "Performing Measurements"](#), on page 60; for a description of the operating concept refer to [Chapter 4.3, "Operating the Instrument"](#), on page 35. For all background and reference information concerning manual and remote control of the instrument, refer to your analyzer's help system or user manual. A more detailed description of the hardware connectors and interfaces is also part of the help system or user manual.

⚠ WARNING**Risk of injury due to disregarding safety information**

Observe the information on appropriate operating conditions provided in the data sheet to prevent personal injury or damage to the instrument. Read and observe the basic safety instructions provided with the instrument, in addition to the safety instructions in the following sections. In particular:

- Do not open the instrument casing.

4.1.1 Unpacking and Checking the Instrument

Check the equipment for completeness using the delivery note and the accessory lists for the various items. If you notice any damage, immediately contact the carrier who delivered the instrument.

**Packing material**

Retain the original packing material. If the instrument needs to be transported or shipped later, you can use the material to protect the control elements and connectors.

⚠ WARNING**Risk of injury during transportation**

The carrying handles at the front and side of the casing are designed to lift or carry the instrument. Do not apply excessive force to the handles. If a handle is ripped off, the falling instrument can cause injury.

4.1.2 Positioning the Instrument

The network analyzer is designed for use under laboratory conditions, either on a bench top or in a rack.

NOTICE

Risk of instrument damage due to inappropriate operating conditions

An unsuitable operating site or test setup can damage the instrument and connected devices. Before switching on the instrument, observe the information on appropriate operating conditions provided in the data sheet. In particular, ensure the following:

- All fan openings are unobstructed and the airflow perforations are unimpeded. A minimum distance of 10 cm to other objects is recommended.
 - The instrument is dry and shows no sign of condensation.
 - The instrument is positioned as described in the following sections.
 - The ambient temperature does not exceed the range specified in the data sheet.
 - Signal levels at the input connectors are all within the specified ranges.
 - Signal outputs are connected correctly and are not overloaded.
-

NOTICE

Instrument damage caused by electrostatic discharge

Electrostatic discharge (ESD) can damage the electronic components of the instrument and the device under test (DUT). Electrostatic discharge is most likely to occur when you connect or disconnect a DUT or test fixture to the instrument's test ports. To prevent electrostatic discharge, use a wrist strap and cord and connect yourself to the ground, or use a conductive floor mat and heel strap combination.

During operation, if the firmware observes a serious unexpected disturbance (e.g. due to ESD), it resets all hardware components to ensure proper instrument functioning. It then restores the user settings to the state before the disturbance and indicates the foregone hardware reset by an "Hardware communication problem [...]" information popup.

4.1.3 Bench Top Operation

If the analyzer is operated on a bench top, the surface must be flat. The instrument can be used in horizontal or vertical position, standing on its feet, or with the support feet on the bottom expanded.

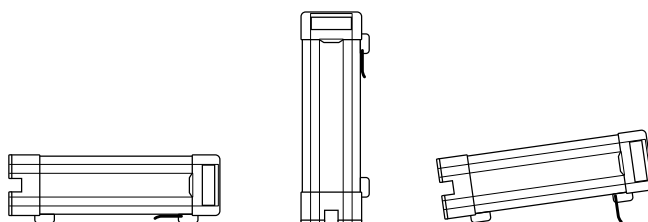
**⚠ WARNING****Risk of injury if feet are folded out**

The feet can fold in if they are not folded out completely or if the instrument is shifted. Collapsing feet can cause injury or damage the instrument.

- Fold the feet completely in or out to ensure stability of the instrument. Never shift the instrument when the feet are folded out.
- When the feet are folded out, do not work under the instrument or place anything underneath.
- The feet can break if they are overloaded. The overall load on the folded-out feet must not exceed 500 N.

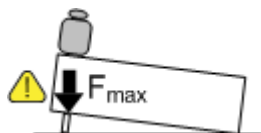

4.1.4 Operation in a 19" Rack

The R&S ZND can be mounted in 19" racks using the adapter R&S ZZA-KN5 (order number 1175.3040.00). Proceed according to the mounting instructions supplied with the rack adapter.

NOTICE**Risk of instrument damage due to insufficient airflow in a rack**

If you mount several instruments in a rack, you need an efficient ventilation concept to ensure that the instruments do not overheat. Insufficient airflow for a longer period can disturb the operation and even cause damage.

4.1.5 EMI Suppression

Electromagnetic Interference (EMI) can affect the measurement results.

To suppress generated Electromagnetic Interference:

- Use suitable shielded cables of high quality (see table below)
- Always terminate open cable ends
- Note the EMC classification in the data sheet

Regarding cable length and quality, the following requirements have to be met:

Table 4-1: Cable Requirements

Cable Type (Connector)	Requirement
RF cables (PORT 1, ..., PORT N)	Double shielded
BNC cables (various)	Double shielded
DB-25 (USER PORT)	Double shielded
GPIB	Standard cable
Handler I/O	Standard cable
DVI-D (Monitor)	2 ferrite cores
LAN	At least CAT6, S/FTP
USB	Standard cables, length ≤ 3m

4.1.6 Connecting the Analyzer to the AC Supply

The network analyzer is automatically adapted to the AC supply voltage, which must be in the range of 100 V to 240 V at 50 Hz to 60 Hz. The mains connector is located in the upper part of the rear panel (see [Chapter 4.2.2, "Rear Panel"](#), on page 34).

- ▶ Connect the network analyzer to the AC power source using the AC power cable delivered with the instrument.

The maximum power consumption and the typical power consumption of the individual analyzer models are listed in the data sheet.

4.1.7 Starting the Analyzer and Shutting Down

The AC power switch is located in the upper part of the rear panel, together with the mains connector; see [Chapter 4.2.2, "Rear Panel"](#), on page 34.

To start the analyzer, proceed as follows:

1. Switch the AC power switch to position I (On).
After power-on, the analyzer automatically goes to standby or ready state, depending on the state of the standby toggle key at the front panel when the instrument was switched off last time.
2. If necessary, press the standby toggle key on the front panel to switch the instrument to ready state (the green LED goes on).

The instrument automatically performs a system check, boots the Windows® operating system and then starts the vector network analyzer (VNA) application. If it was terminated regularly, the VNA application restores all recall sets and instrument settings of the previous analyzer session.

To shut down the analyzer, proceed as follows:

1. Press the standby key.

Pressing the standby key causes the instrument to save all loaded recall sets, to close the VNA application, to shut down Windows®, and to go to standby state. Of course, you can also perform these steps manually, like in any Windows session.

2. If desired, set the AC power switch to position **O** (Off).

NOTICE

Risk of data loss

It is recommended to switch the analyzer to standby state before disconnecting it from the AC supply. If you set the power switch to 0 while the VNA application is still running, you lose the current settings. Moreover, loss of program data cannot be excluded if the application is terminated improperly.



The AC power switch can be permanently on. It is recommendable, however, to switch it off if the instrument is not used for some time. When you switch the instrument back on, be sure to comply with the extended warm-up phase specified in the data sheet.



To guarantee the specified functionality, after turning off the R&S ZND, you have to wait for at least 10 seconds before turning it on again. This rule applies to both the AC power off and the standby state.

4.1.8 Standby and Ready State



The standby toggle key is located in the bottom left corner of the front panel.

In standby state, the right, amber LED is on. The standby power only supplies the power switch circuits. In this state, it is safe to switch the AC power off and disconnect the instrument from the power supply.

In ready state, the left, green LED is on and all modules are power-supplied. When switched to ready state, the analyzer initiates its startup procedure.

Observe the instructions for startup and shutdown in [Chapter 4.1.7, "Starting the Analyzer and Shutting Down"](#), on page 23.

4.1.9 Connecting External Accessories

The analyzer's standard PC interfaces (Monitor, USB, LAN) can be used to connect various accessories:

- An external monitor expands/displays the Windows® desktop, which is, by default, covered by the Vector Network Analyzer (VNA) application window in full-screen mode.

- External keyboard and mouse simplify local control, in particular manual (GUI) operation of the VNA application.
- A printer can be used to create hard copies of the measurement diagrams and traces from within the VNA application.
- A LAN connection can be established to access the analyzer's mass storage or control the analyzer from an external PC.



External monitor, keyboard and mouse are not required for local operation. A R&S ZND can be fully controlled by tapping the touchscreen and front panel keys.

4.1.9.1 Connecting a Monitor



A standard monitor can be connected to the DVI-D connector on the rear panel of the R&S ZND. No extra configuration is required.

NOTICE

Safety aspects

The monitor must be connected while the instrument is switched off (or in standby mode). Otherwise correct operation cannot be guaranteed.

Select SYSTEM > [DISPLAY] > "View Bar" > "Hard Key Panel On" from the menu bar of the VNA application window to add the (virtual) "Hard Key Panel" to the application window.

4.1.9.2 Connecting a Keyboard

A keyboard can be connected to any of the USB connectors. After being auto-detected by the operating system, it can safely be disconnected and reconnected even during measurements.

Keyboard configuration

The default input language is English – US. Select "Settings" > "Time & language" > "Region & language" from the Windows® Start menu to manage languages and keyboards.

Windows 7: select "Control Panel" > "Clock, Language, and Region" > "Region and Language" > "Keyboards and Languages" from the Windows® Start menu to configure the keyboard properties.



To access Windows®, use the  button in the **toolbar** of the application window.

4.1.9.3 Connecting a Mouse

A USB mouse can be connected to any of the USB connectors. After being auto-detected by the operating system, it can safely be disconnected and reconnected even during measurements.

Mouse configuration

Select "Settings" > "Devices" > "Mouse & touchpad" from the Windows® "Start" menu to configure the mouse properties.

Windows 7: select "Control Panel" > "Hardware and Sound" > "Devices and Printers" > "Mouse" from the Windows® "Start" menu to configure the mouse properties.



To access Windows®, use the  button in the **toolbar** of the application window.

4.1.9.4 Connecting a Printer

A printer can be connected to any of the USB connectors. After successful installation, it can safely be disconnected and reconnected even during measurements.

Before printing (SYSTEM – [PRINT]), the analyzer checks whether a printer is connected and turned on and whether the appropriate printer driver is installed.

Printer driver installation

If necessary, the printer driver installation is initiated using the operating system's "Add Printer Wizard". The wizard is self-explanatory. A printer driver must be installed only once.

A great variety of printer drivers is available on the analyzer. To obtain the complete list, select "Settings" > "Devices" > "Printers & scanners" from the Windows® "Start" menu.

Windows 7: select "Control Panel" > "Hardware and Sound" > "Devices and Printers" from the Windows® "Start" menu.



To access Windows®, use the  button in the **toolbar** of the application window.

You can load updated and improved driver versions or new drivers from an installation disk, USB memory stick or another external storage medium. Alternatively, if the analyzer is integrated in a network, you can install driver data stored in a network directory. In either case, use the "Add Printer" wizard to complete the installation.

Printer configuration

Use the "Printer Setup" dialog of the firmware (SYSTEM – [PRINT] > "Print...") or the Windows® printer management to configure the printer properties and printing preferences.

4.1.9.5 Connecting a LAN Cable

A LAN cable can be connected to the LAN connector on the rear panel of the analyzer. To establish a LAN connection, proceed as follows:

1. Refer to [Chapter 11.1.3.1, "Assigning an IP Address"](#), on page 1151.
2. Connect a CAT6 or CAT7 LAN cable to the LAN port.

The LAN port of the analyzer is an auto-crossover Ethernet port. You can connect it to a network, but you can also set up a direct connection to a computer or another instrument. For both connection types, you can use either crossover or straight through (patch) cables.

The IP address information is displayed in the SYSTEM – [SETUP] > "Remote Settings" softtool tab.

4.1.10 Minimizing the VNA Application

With a minimized VNA application, you can access your analyzer's Windows® desktop or run other applications.

To exit the default full-screen mode of the VNA application, deselect SYSTEM – [DISPLAY] > "View Bar" > "Title Bar Task Bar". Then use the standard Windows® titlebar functions to minimize/maximize/close the application window.

To start the VNA application with a minimized window

1. Right-click the Vector Network Analyzer shortcut icon on the desktop and open the "Properties" dialog.
2. In the "Shortcut" tab, select "Run: Minimized".

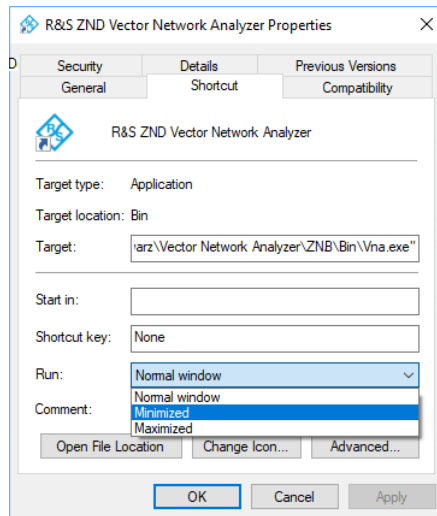

A software update restores the original shortcut properties.

4.2 Instrument Tour

This chapter gives an overview of the control elements and connectors of the R&S ZND and gives all information that is necessary to put the instrument into operation and connect external devices.

4.2.1 Front Panel

The front panel of the network analyzer consists of the touchscreen with the diagrams and softtool panels (left side), the hardkey area (right side) and the test port area below. Brief explanations on the controls and connectors, the hardkey area and the rear panel can be found on the next pages.



Figure 4-1: Front View of R&S ZND

NOTICE

Instrument damage caused by cleaning agents

Cleaning agents contain substances such as solvents (thinners, acetone, etc.), acids, bases, or other substances. Solvents can damage the front panel labeling, plastic parts, or screens, for example.

Never use cleaning agents to clean the outside of the instrument. Use a soft, dry, lint-free dust cloth instead.

4.2.1.1 Touchscreen

The analyzer is equipped with a 12.1" XGA color touchscreen. The touchscreen presents all measurement results, mostly in the form of diagrams. Besides, all instrument functions can be accessed and operated by tapping the control elements on the touchscreen. For an introduction to touchscreen operation, refer to [Chapter 4.3.1, "Manual Operation"](#), on page 36.

The following sections contain further useful information about manual control of the instrument.

- Refer to the other sections in chapter [Chapter 4.3, "Operating the Instrument"](#), on page 35 to learn how to handle traces and diagrams, and how to use menus, keys and softtools.
- Refer to [Chapter 5.2.1, "Display Elements of a Diagram"](#), on page 81 to obtain information about the results in the diagram.
- Refer to section [Chapter 6.16, "Display Softtool"](#), on page 503 to learn how to customize the screen.

- Refer to the data sheet for the technical specifications of the display.



Screen saver

The screen saver function of the operating system can be used to switch off the display if the analyzer receives no command for a selectable period of time. The display is switched on again if any front panel key is pressed.

To enable the screen saver, access the Windows® operating system (e.g. by pressing the Windows key in the SYSTEM keypad) and tap "Control Panel > Power Options > Change Plan Settings > Turn off the display".

(Windows 7: "Control Panel > Hardware and Sound > Power Options > Edit Plan Settings > Turn off the display").

4.2.1.2 Function Keys

Most of the keys in the TRACE, CHANNEL, STIMULUS, and SYSTEM keypads call up a related softtool of the analyzer GUI. Every softtool provides access to a group of related measurement settings.



The TRACE keys give access to all trace settings, to the limit check settings, and to the marker functions including marker search.

- The [MEAS] settings select the measured and displayed quantity.
- The [FORMAT] settings define how measured data (traces) are presented.
- The [SCALE] settings define how traces are scaled.
- The [TRACE CONFIG] settings store traces to the memory and perform mathematical operations on traces.
- The [LINES] settings define limits for the measurement results, visualize them in the diagrams and activate/deactivate the limit check.
- The [MARKER] settings position markers on a trace, configure their properties and select the format of the numerical readout. Markers can also be used to locate specific points on the trace, define the sweep range, and scale the diagram.



The CHANNEL keys give access to the hardware-related (channel) settings.

- The [POWER BW AVG] settings define the power of the internal signal source, the IF bandwidth, and the sweep average.
- The [SWEEP] settings define the scope of measurement, including the sweep type and the number of measured sweeps.
- [CAL] provides all functions that are necessary to perform a system error correction (calibration).
- [CHANNEL CONFIG] provides functions for channel management.
- The [TRIGGER] settings control the start of the measurement sequence.
- [OFFSET EMBED] provides a selection of length offset parameters to shift the measurement plane.



The STIMULUS keys ([START], [STOP], [CENTER], [SPAN]) define the sweep range, depending on the sweep type.



The SYSTEM keys provide general system settings.

- [FILE] provides standard Windows® functions used to create, save, recall or print recall sets, to copy the active screen and to shut down the application.
- The [PRINT] settings control an external printer that is used to print a hardcopy of the current recall set.
- [APPLIC] gives access to external software tools and optional extensions of the analyzer firmware.
- [DISPLAY] gives access to all display settings and to the functions which activate, modify and arrange different diagrams.
- [SETUP] provides general system settings which are not restricted to a particular recall set.
- The Windows® key opens the startup menu of the Windows® operating system from where you can perform system configurations and call up additional software utilities.
- [HELP] opens the context-sensitive help system of the analyzer.
- [PRESET] performs a preset of the instrument settings.

4.2.1.3 Data Entry Keys



The keys in the DATA ENTRY keypad are used to enter numbers, units, and characters. The data entry keys are only enabled while the cursor is placed on a data input field in a dialog or in the Help navigation pane.

- The keys 0 to 9 enter the corresponding numbers.
- The function of the "." and "-" keys depends on the data type of the active input field:
 - In numeric input fields, the keys enter the decimal point and a negative sign for the entered numeric value. Multiple entries have no effect.
 - In character input fields, the keys enter a dot and a hyphen, respectively. Both entries can be repeated as often as desired.
- The function of the four unit keys depends on the data type of the active input field; see [Chapter 4.3.5, "Entering Data"](#), on page 51.
 - In numeric input fields, the G/n, M/μ, k/m or x1 keys multiply the entered value with factors of $10^{(-)9}$, $10^{(-)6}$, $10^{(-)3}$ or 1 and add the appropriate physical unit. x1 is equivalent to ENTER and confirms the previous entry.
 - In character input fields, the G/n, M/μ, k/m keys enter the letters G, M, K, respectively. x1 is equivalent to ENTER and confirms the previous entry.
- ESC is used to:
 - Cancel entries / close dialogs without activating the entries made (equivalent to the "Close" button).
 - Close the Help system.
- ENTER is used to:
 - Activate the selected active control element, e.g. a button in a dialog or a link in the "Contents" page of the Help system.

- Confirm selections and entries made and close dialogs (equivalent to the "OK" button).
- Compress or expand menus or the Help table of contents
- BACKSPACE deletes the last character before the cursor position or the selected character sequence or numeric value.

4.2.1.4 Rotary Knob



The rotary knob increases and decreases numerical values, scrolls within lists, activates controls and confirms entries. Turning or pressing the rotary knob is equivalent to the action of the "Cursor Up" and "Cursor Down" navigation keys or of the ENTER key in the DATA ENTRY keypad, respectively.

STEP SIZE opens an input box to select the steps (in units of the current physical parameter) between two consecutive numerical values. The step size is also valid for value changes using the "Cursor Up" and "Cursor Down" keys. See also [Chapter 4.3.5.2, "Using the Numeric Editor"](#), on page 52.

4.2.1.5 Navigation Keys

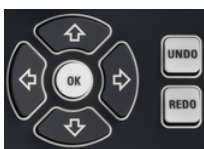

The keys in the NAVIGATION keypad are used to navigate within the touchscreen and the help system, to access and control active elements.

The "Cursor Up" and "Cursor Down" keys are used to:

- Scroll up and down in lists, e.g. among menu items, in a list of keywords, in the Help table of contents, or in the Help index
- Navigate between table rows in diagrams. Press "OK" to toggle between navigation mode and data entries.
- Increase and decrease numerical input values

"Cursor Up" (Down) become inactive as soon as the beginning of the list is reached. "Cursor Up" (Down) is equivalent to a rotation of the rotary knob to the right (left).

The "Cursor Left" and "Cursor Right" keys are used to:

- Move the cursor to the left or right within input fields
- Navigate between table columns in diagrams. Press "OK" to toggle between navigation mode and data entries.
- Compress or expand menus or the Help table of contents
- Move the highlighted item in the menu bar of the active application

ENT OK is equivalent to the action of the ENTER key in the DATA ENTRY keypad.

UNDO reverses the last action, if possible. REDO reverses the action of the UNDO button.

4.2.1.6 Standby Key



The standby toggle switch is located in the bottom left corner of the front panel.

The key serves two main purposes:

- Toggle between standby and ready state; see [Chapter 4.1.8, "Standby and Ready State"](#), on page 24.
- Shut down the instrument; see [Chapter 4.1.7, "Starting the Analyzer and Shutting Down"](#), on page 23.

4.2.1.7 Front Panel Connectors

The test ports and four USB connectors are located on the front panel of the analyzer.

Test Ports



Numbered type N female connectors.

The test ports serve as outputs for the RF stimulus signal and as inputs for the measured RF signals from the DUT (response signals).

- With a single test port, it is possible to generate a stimulus signal and measure the response signal in reflection. For a measurement example, refer to [Chapter 4.4.2, "Reflection S-Parameter Measurement"](#), on page 67.
- With 2 test ports, full two-port measurements are possible; see [Chapter 5.3.1, "S-Parameters"](#), on page 104.

However, to use port 2 of a R&S ZND as driving port, you need one of the "bidirectional measurements" options:

- R&S ZND-K5, for a R&S ZND without "extended frequency range" option
R&S ZND-K1
- R&S ZND-K6, for a R&S ZND with "extended frequency range" option
R&S ZND-K1

NOTICE

Maximum input levels

The maximum input levels at all test ports according to the front panel labeling or the data sheet must not be exceeded.

In addition, the maximum input voltages of the other input connectors at the rear panel must not be exceeded.



Use a torque wrench when screwing RF cables on the test port connectors.

USB Connectors

Four USB 2.0 connectors of type A (master USB).



The USB ports can be used to connect:

- External PC accessories such as mouse or other pointing devices, a keyboard, printer or external storage device (USB stick, CD-ROM drive etc.).
- External measurement equipment such as a calibration unit, power meter or switch matrix.

4.2.2 Rear Panel

This section gives an overview of the rear panel controls and connectors of the network analyzer.



Figure 4-2: Rear Panel R&S ZND

The following connectors are available on all instruments:

- LAN is an RJ-45 connector. Use this connector to integrate the instrument to a Local Area Network, primarily for remote control purposes; see [Chapter 11.1.3.1, "Assigning an IP Address"](#), on page 1151. See also [Chapter 11.3.2, "LAN Interface"](#), on page 1157.
- Connector DVI can be used to connect an external monitor; see [Chapter 4.1.9.1, "Connecting a Monitor"](#), on page 25.
- USER PORT is a 25-pin D-Sub connector used as an input and output for low-voltage (3.3 V) TTL control signals. See [Chapter 11.3.1.1, "USER PORT"](#), on page 1156.
- EXT TRIG IN and EXT TRIG OUT are two BNC connectors for 5 V TTL external trigger signals. See [Chapter 6.10.3, "Trigger Tab"](#), on page 365.
- REF OUT is a BNC output for the internal reference frequency of the R&S ZND. Use this connector to synchronize other instruments to the analyzer.

- REF IN is a BNC input for an external reference frequency. Use this connector to synchronize the R&S ZND to another device.
- SYSTEM DRIVE contains the removable system drive of the R&S ZND, containing all software (including the operating system and the VNA application) and data. Do not remove the system drive during operation.
See [Chapter 5.7.16, "Additional Removable System Drive"](#), on page 207.
- The ground connector in the lower left corner of the rear panel provides the ground of the analyzer's supply voltage. Use this connector for ESD protection; see "[Instrument damage caused by electrostatic discharge](#)" on page 21.

The following optional connectors can be installed in addition:

- Option R&S ZND-B10 provides a GPIB bus connector according to standard IEEE 488 / IEC 625.
See [Chapter 11.3.3, "GPIB Interface"](#), on page 1158.
- Option R&S ZN-B14, Handler I/O (Universal Interface), provides a Centronics 36 input/output connector.
See [Chapter 11.3.4, "Handler I/O \(Universal Interface\)"](#), on page 1161.

NOTICE

Input levels, EMC

The maximum input levels and voltages of the input connectors at the front and rear panel must not be exceeded. Match signals with 50 Ω to comply with EMC directives. See also [Chapter 4.1.5, "EMI Suppression"](#), on page 22.

4.3 Operating the Instrument

The following sections describe the basics of manual operation, i.e. how to access instrument functions and settings via the analyzer GUI. Manual operation is particularly useful for getting to know the instrument and for trouble shooting.

Manual and remote control of the instrument

Manual control of the R&S ZND is possible either via its touchscreen and frontpanel keys, via locally connected keyboard and mouse (see [Chapter 4.1.9, "Connecting External Accessories"](#), on page 24), or via Remote Desktop (see also [Chapter 11.1.3, "Remote Operation in a LAN"](#), on page 1150). Alternatively it can be remote-controlled via the GPIB interface or a LAN connection.

Manual operation and remote control are described to their full extent in the [GUI Reference](#) and [Command Reference](#) chapters, respectively. GUI functions and their related remote commands are linked bidirectionally. Background information is provided in the [Concepts and Features](#) chapter.

4.3.1 Manual Operation

The analyzer functions are accessible via several tabbed softtools, each presenting related functions and settings. The keys on the front panel or the on-screen "Hard Key Panel" open the most frequently used softtools.

Manual operation via function keys and softtools provides touch-friendly access to the instrument functions and settings, avoiding complicated menu structures and long operating sequences. In general, this approach is recommended. However, sometimes the toolbar or an object's context menu can offer a shortcut. As a full-fledged alternative for manual operation via mouse and keyboard, also the menu bar provides access to all instrument functions and settings.



Figure 4-3: Function Keys



Customizing the screen

The contents of the screen and the size and position of many display and control elements are not fixed. You can display or hide most elements. You can also drag and drop traces, info fields, and even the softtool panel to your preferred position; see [Chapter 4.3.4.4, "Using Drag and Drop"](#), on page 50.

For example, you can show/hide the on-screen hardkey panel by selecting/deselecting "Display" > "View Bar" > "Hard Key Panel On" from the main menu.

The following table shows possible touchscreen operations with the corresponding mouse operations.

Touchscreen	Mouse	Typical task
Tap control element for a short time	Click control element (left mouse button)	Select button or tab
Tap for an extended time (tap and hold)	Click (right button)	Open context menu
Tap twice (double-tap)	Double-click (left button)	Open on-screen keyboard

Using the Front Panel

To access an instrument function:

1. Press a (virtual) key, e.g. the [MEAS] key in the TRACE section.

The corresponding softtool expands at the current docking position.



left = unidirectional R&S ZND
right = bidirectional R&S ZND

2. Activate the desired softtool tab, e.g. "Z←Sij".

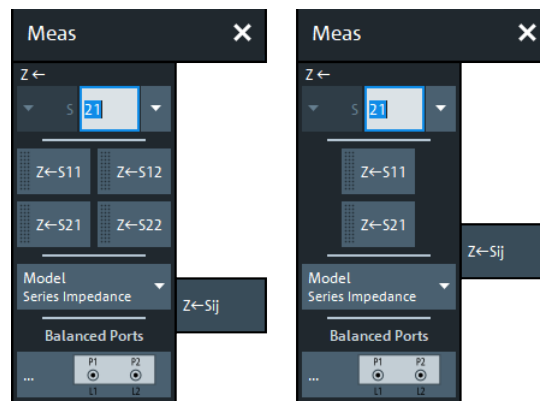

left = unidirectional R&S ZND
right = bidirectional R&S ZND

3. Select a control element, e.g. "Z←S11".

The diagram immediately reflects your selection. The active trace shows the measurement results for the selected measured quantity.

A control element with three dots (e.g. SYSTEM – [SETUP] > "Setup" > "System Config...") opens a dialog, containing a group of related settings, a wizard or additional information.

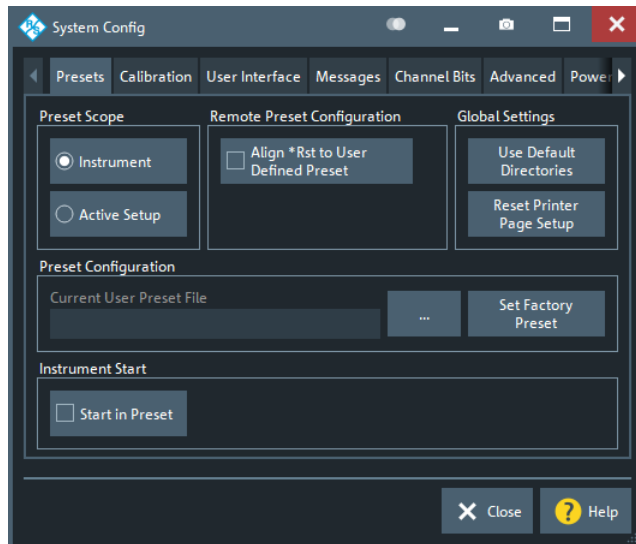

Using the menu bar

The menu bar at the bottom of the application screen provides alternative access to **all** instrument functions. To repeat the measured quantity selection described above,

- ▶ Select TRACE – [MEAS] > "Z←Sij" > "Z←S11".

The diagram immediately reflects your selection. The active trace shows the measurement results for the selected measured quantity. At the same time, the related softtool tab is opened.

Using context menus

Context menus are another alternative for quick access to instrument settings.

1. Touch and hold (right-click) the measured quantity section in the trace info for a couple of seconds until the context menu appears.

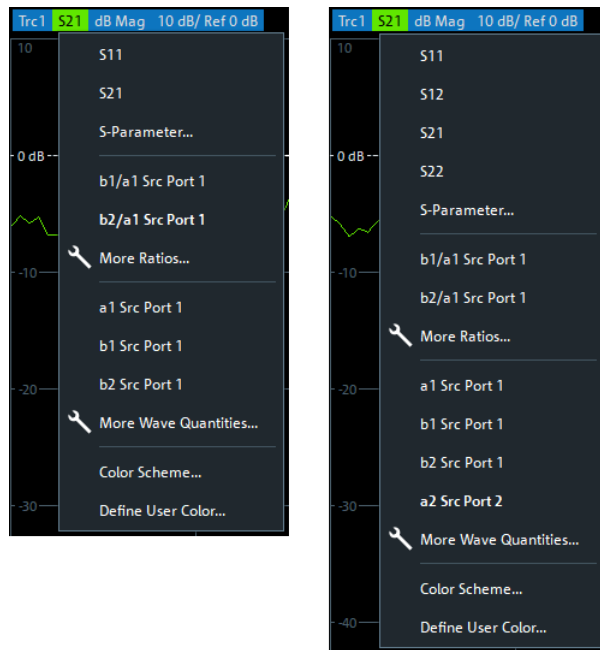

left = unidirectional R&S ZND
 right = bidirectional R&S ZND

2. Select "S-Parameter" to open the "Meas" > "S-Params" softtool tab.

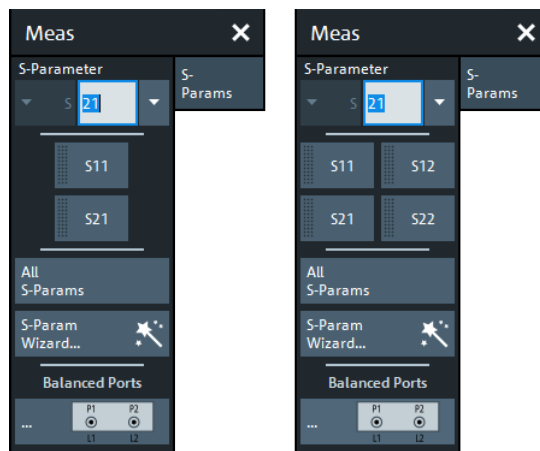

left = unidirectional R&S ZND
 right = bidirectional R&S ZND

3. Select "Z←Sij" > "Z←S11".

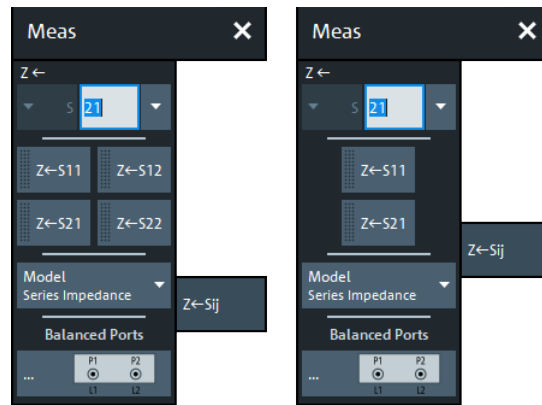

left = unidirectional R&S ZND

right = bidirectional R&S ZND

4.3.2 Control Elements of the Application Window

The application window of the analyzer provides all control elements for the measurements and contains the diagrams for the results. There are several alternative ways for accessing an instrument function:

- Using a function key on the (virtual) hardkey panel to open the related softtool (recommended, provides all settings)
- Using the menus and submenus of the menu bar (alternative to the previous method)
- Using the context menus of certain display objects (for important actions in the context of this object)
- Using the icons in the toolbar above the diagram area (for frequent global actions)



These methods are described in more detail in the following sections.

For further reference:

- Refer to [Chapter 5.2.1, "Display Elements of a Diagram"](#), on page 81 to obtain information about the results in the diagram.
- Refer to [Chapter 6.16, "Display Softtool"](#), on page 503 and learn how to customize the screen.

4.3.2.1 Title Bar

By default, the analyzer GUI is shown in full screen mode, covering the whole screen and hiding the Windows taskbar. However, you can toggle the full screen mode using **SYSTEM – [DISPLAY] > "View Bar" > "Title and Task Bar On"**.

If full screen mode is switched off, the main application window of the vector network analyzer application provides a standard Windows® title bar.









4.3.2.2 Toolbar

The toolbar above the diagram area contains the most frequently used control elements of the user interface. All controls are also accessible via [Softtools](#).



The toolbar is divided into several icon groups, separated by vertical lines.

	<p>These icons represent the undo and redo actions that are also available via the menu bar items "System" > "Undo" / "Redo".</p> <p>Undo reverses the last action, redo reverses the last undo action (if possible).</p>
	<p>These icons control the zoom function (TRACE – [SCALE] > "Zoom").</p>
	<p>If multiple diagrams are configured, this icon toggles the "Maximize Diagram" action for the active diagram (SYSTEM – [DISPLAY] > "Diagram" > "Maximize Diagram").</p>
	<p>These icons implement the following actions, from left to right:</p> <ul style="list-style-type: none"> • Add a clone of the active trace to the active diagram (single tap; same as TRACE – [TRACE CONFIG] > "Traces" > "Add Trace") or to an arbitrary/new one (drag & drop the "Trc+" icon to the diagram area). • Add a new marker to the active diagram (single tap; similar to TRACE – [MARKER] > "Markers" > "Mkr<i>+</i>") or to an arbitrary one (drag & drop the "Mkr+" icon). • Delete the active trace (single tap the trash icon), or an arbitrary trace (drag & drop its trace info field to the trash icon). Or delete all markers of a trace (drag & drop the marker info field to the trash icon).
	<p>These icons provide the following actions, from left to right:</p> <ul style="list-style-type: none"> • Print the current diagrams to a bitmap file (same as SYSTEM – [FILE] > "Print" > "To File..."). By default, all diagrams are printed, no matter if displayed or not. However you can also choose to print only the active diagram (see SYSTEM – [FILE] > "Print" > "Print..."). • Open the Windows® Start menu. • Open the context-sensitive help. • Restart the sweep in all channels (same as CHANNEL – [SWEEP] > "Sweep Control" > "Restart Sweep")
	<p>These icons provide the following actions, from left to right:</p> <ul style="list-style-type: none"> • Toggle advanced diagram area editing, which makes rearranging and/or deleting diagrams a breeze. • Toggle other measurements (except the active trace) OFF ON



You can hide the toolbar using SYSTEM – [DISPLAY] > "View Bar".

4.3.2.3 Softtools

Softtools display groups of related settings as a tabbed panel. They can be opened via function keys on the front panel or the on-screen "Hard Key" panel, or via menu bar and context menu items.

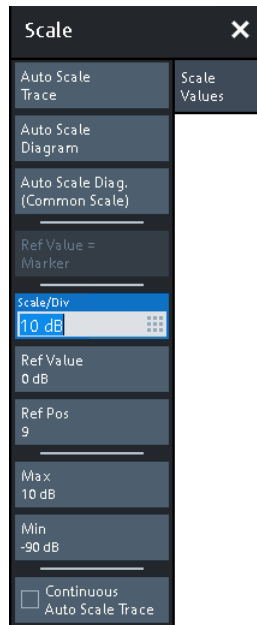

Figure 4-4: Scale softtool

A softtool consists of a title area with a close/re-open icon and a tabbed panel below it. The title area remains displayed when the softtool is closed, which allows you to reopen a closed softtool at any time.

Some controls on the softtool tabs allow you to read and modify settings (e.g. "Ref Value" in the screenshot above), some perform actions (e.g. "Auto Scale Trace"), while others open additional dialogs (button label ends with "...").

4.3.2.4 Menu Bar

You can also access the analyzer functions via textual menus. The menu bar is located below the diagram area:

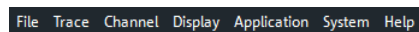

As in any Windows® application, menus can be controlled with the touchscreen or a mouse. A short tap (left mouse click) expands a menu or submenu. If a menu command has no submenu assigned, a short tap (left mouse click) opens a dialog or directly activates the menu command. When a (sub)menu is selected, the R&S ZND displays the corresponding softtool.

Overview of menu functions

- The "File" menu provides functions to handle recall sets and trace files, to print or save diagram content, and to shut down the VNA application.
- The "Trace" menu provides all trace settings, the limit check settings, and the marker functions including marker search.
- The "Channel" menu provides all channel settings and activates, modifies or stores different channels.

- The "Display" menu provides all display settings and the functions for activating, modifying and arranging different diagrams.
- The "Application" menu gives access to applications and tools that extend the functionality of the analyzer firmware.
- The "System" menu provides functions that can be used to return to a defined instrument state, reverse operations, access service functions and define various system-related settings.
- The "Help" menu provides assistance with the network analyzer and its operation.



You can toggle the visibility of the menu bar using SYSTEM – [DISPLAY] > "View Bar" > "Menu Bar".

4.3.2.5 Menu Structure

All menus show an analogous structure.

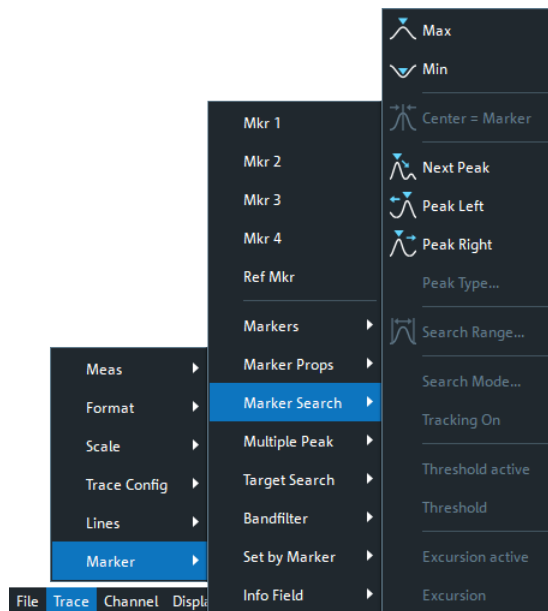

- A menu command with a right arrow expands a submenu with further related settings.
Example: "Marker" expands a submenu with marker-related properties.
- A menu command with three dots appended calls up a dialog providing several related settings.
Example: "Search Range" opens a dialog to define the search range for the marker search.
- A menu command with no arrow or dots initiates an immediate action.
Example: "Max" sets the active marker to the maximum of the active trace.

4.3.2.6 Hardkey Panel

The (virtual) "Hard Key" panel provides on-screen access to the function keys (plus the [UNDO] and [REDO] key) of the R&S ZND. Most of the function keys open a related softtool. For a short description, refer to section [Chapter 4.2.1.2, "Function Keys"](#), on page 30.

Trace	
Meas	Format
Scale	Trace Config
Line	Marker
Stimulus	
Start	Stop
Center	Span
Channel	
Channel Config	Sweep
Power Bw Avg	Trigger
Cal	Offset Embed
System	
File	Print
Display	Setup
Applic	Preset



The "Hard Key" panel is particularly useful if the analyzer is controlled from an external monitor or Remote Desktop.

For the R&S ZND, it is hidden by default.

You can display the "Hard Key" panel using one of the following methods:

- Select SYSTEM – [DISPLAY] > "View Bar" > "Hard Key Panel".
- Select "Display"> "View Bar" > "Hard Key Panel On" from the menu bar.
- Select "Hard Key" from the context menu of the softtool panel.

4.3.2.7 Status Bar

The status bar shows

- the active channel
- the current channel's sweep averaging counter (e.g. "Ch<i>: Avg 9/10"), or "Ch<i>: Avg None" if averaging is disabled
- the progress of the sweep
The progress bar also shows when the R&S ZND prepares a sweep with new channel settings
(See [Chapter 5.1.4, "Sweep Control"](#), on page 72)

- the "EXT REF" symbol, if an external reference clock is used for synchronization (see "Ext Frequency" on page 539)
- the switch matrix status symbol, if a switch matrix is configured (See Chapter 5.7.20, "External Switch Matrices", on page 210)
- the current date and time

Ch1: Avg None   1/3/2018 6:33:23 PM

Figure 4-5: R&S ZND with switch matrix



The progress bar shows a moving color gradient if the current sweep is too fast to be monitored, e.g. because the number of sweep points is low. You can hide/show the status bar using SYSTEM – [DISPLAY] > "View Bar" > "Status Bar".

4.3.3 Working with Dialogs

Dialogs provide groups of related settings and allow to make selections and enter data in an organized way. The settings are visualized, if possible. An example is shown below.

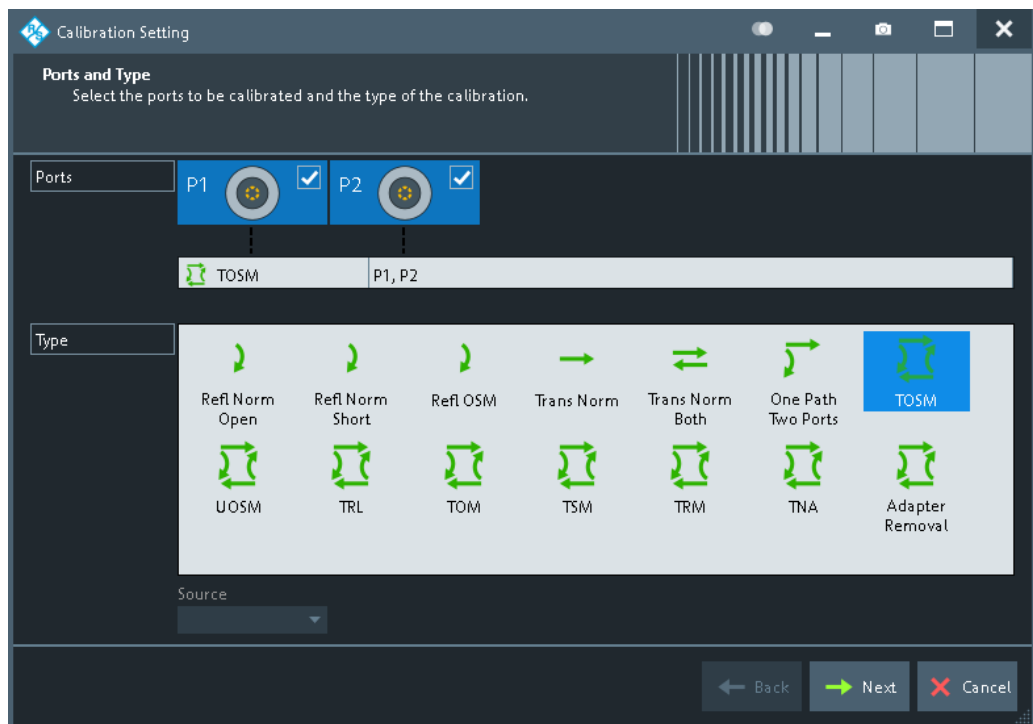

For a unidirectional R&S ZND, the bidirectional calibrations are not available.

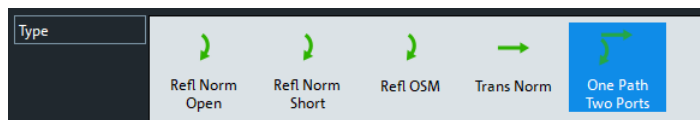

All dialogs are operated in a similar way.

- To open a dialog, select a softtool button with three dots appearing in its label (e.g. "Start... (Manual)").
- The title bar of each dialog contains some convenience functions:
 - Use the "Dialog Transparency" function to make the display elements behind the dialog visible.

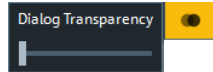

Note: The "Dialog Transparency" is a global setting, i.e. it applies to all dialogs.

- Use the  icon to create a screenshot of the dialog.
- Drag and drop the lower right corner of the dialog to modify its size.
- Some dialogs are subdivided into tabs, containing groups of related settings. Activate a tab to access those settings.

See also [Chapter 5.2.2.1, "Immediate vs. Confirmed Settings"](#), on page 92.



The Help system provides useful information about each dialog's specific settings. Select "Help" to open the Help.

4.3.4 Handling Diagrams, Traces, and Markers

The analyzer displays measurement results as traces in rectangular diagrams. Markers are used to read specific numerical values and to search for points or regions on a trace. The following section presents some of the graphical tools the R&S ZND provides for trace and marker handling.



For further reference

Refer to [Chapter 5, "Concepts and Features"](#), on page 69 to learn more about traces, channels, and screen elements.

4.3.4.1 Adding New Traces and Diagrams

A new trace is required if you want to measure and display an additional quantity.

Typical scenario: The transmission coefficient S_{21} is measured as described in [Chapter 4.4.1, "Transmission S-Parameter Measurement"](#), on page 60. A trace is added to display the reflection coefficient S_{11} for comparison.



To create a trace:

1. Drag the "Trc+" icon from the toolbar into a diagram.

The diagram changes its color scheme and contents as shown below.

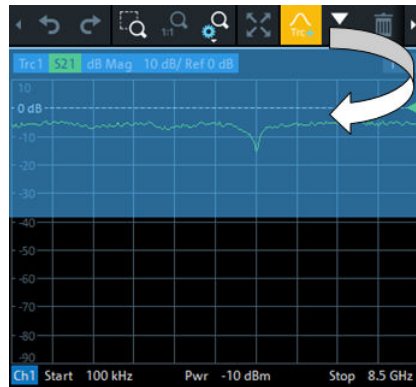

2. Select the adequate drop position, depending on whether you want to display the new trace in the existing diagram, or whether you want to add a new diagram. The highlighted area indicates the target diagram.

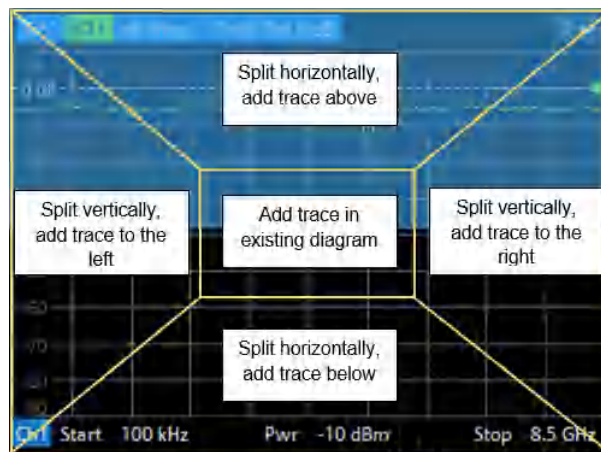

3. In the dialog box that is opened when you release the "New Trace" icon, select the S-parameter to be measured.

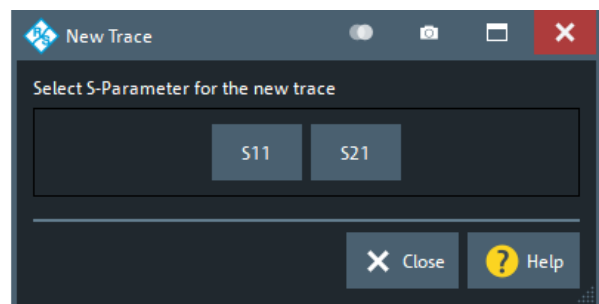
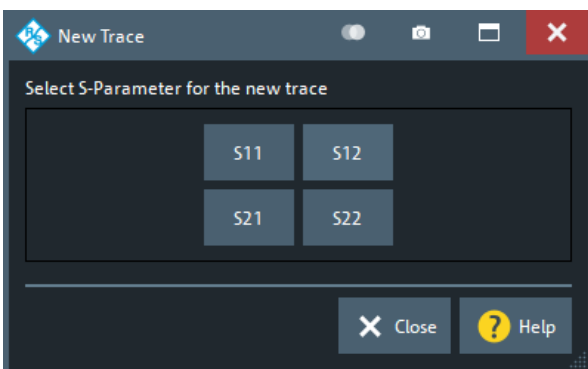

left = bidirectional R&S ZND
 right = unidirectional R&S ZND

The R&S ZND generates a new trace for the selected S-parameter.



Alternative control elements

To measure a different quantity, select TRACE – [MEAS]. Drag and drop a softkey representing a measured quantity to create a trace. Or simply select another softkey to change the measured quantity of the active trace.

Select TRACE – [TRACE CONFIG] to access more trace handling functions. Select SYSTEM – [DISPLAY] to access more diagram handling functions.

4.3.4.2 Adding New Markers

A marker is needed, for instance, to read a particular numerical trace value.



To add a new marker:

- Drag and drop the "New Marker" icon from the toolbar to the desired position in the target diagram.



The marker appears on the target diagram's active trace. The marker info field displays the stimulus value (x-axis value) and response value (y-axis value) at the marker position. The response value varies as the analyzer continues performing sweeps.

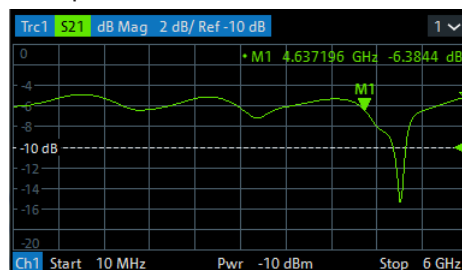

Active trace, alternative control elements

The trace line of the active trace in the upper part of the diagram is highlighted. If the diagram contains several traces, first activate the target trace, then add the marker.

The TRACE – [MARKER] softtool provides more functions for marker handling. In particular, any marker offered in the "Markers" tab can be positioned on the active trace using drag & drop.

4.3.4.3 Deleting Display Elements



Markers, traces, diagrams, and other display elements are most conveniently deleted using the "Delete" icon in the toolbar above the diagram area.

- To delete a single marker, drag it into vertical direction to release it from the trace and drop it onto the "Delete" icon.
To delete a set of markers, drag and drop their marker info field onto the "Delete" icon.
Deleting a marker and its info field also disables the associated marker function.
- To delete a trace, drag and drop its trace line onto the "Delete" icon. The active trace can also be deleted by tapping/clicking the "Delete" icon.
Note however, that the last remaining trace cannot be deleted.
- To delete a diagram, drag and drop its diagram number label onto the "Delete" icon.
Note however, that the last remaining diagram cannot be deleted.
- To delete a channel, drag and drop all associated traces onto the "Delete" icon.
Note however, that the last remaining channel cannot be deleted.
- To hide the limit lines and disable the limit check, drag and drop the PASS / FAIL message onto the "Delete" icon. The limit line itself is not deleted; you can re-use it any time.

The context menu of some display elements also provides the "Delete" function.



Undo function

If you happen to delete a display element unintentionally, you can restore it using the "Undo" toolbar icon.

4.3.4.4 Using Drag and Drop

You can drag and drop many of the R&S ZND's control and display elements to change their size and position. The drag and drop functionality is often more convenient to use than the equivalent buttons of the softtool panels. The following table gives an overview.

Table 4-2: Drag and drop functionality for various screen elements

Screen element	Action	Drag and drop...
Diagram	Create	See Chapter 4.3.4.1, "Adding New Traces and Diagrams" , on page 47
	Resize	Separator between adjacent diagrams
	Delete	See Chapter 4.3.4.3, "Deleting Display Elements" , on page 50
Trace	Create	See Chapter 4.3.4.1, "Adding New Traces and Diagrams" , on page 47
	Move vertically	Reference line marker (right diagram edge)
	Move into other or new diagram	Trace line
	Delete	See Chapter 4.3.4.3, "Deleting Display Elements" , on page 50

Screen element	Action	Drag and drop...
	Reset / suspend graphic zoom	"Zoom" element in additional trace line --> "Delete" icon; see Chapter 4.3.6.1, "Using the Graphical Zoom" , on page 54
Marker	Create	See Chapter 4.3.4.2, "Adding New Markers" , on page 49
	Move horizontally	Marker symbol
	Delete	Marker or marker info field --> "Delete" icon; see Chapter 4.3.4.3, "Deleting Display Elements" , on page 50
Marker info field	Add	See Chapter 4.3.4.2, "Adding New Markers" , on page 49
	Move within diagram	Marker info field (move to one of several pre-defined positions)
	Delete	See Chapter 4.3.4.3, "Deleting Display Elements" , on page 50

4.3.5 Entering Data

The analyzer provides dialogs with various types of input fields where you can enter numeric values and character data. Data entry with a mouse and an external keyboard is a standard procedure known from other Windows® applications. However, there are various other ways to enter data.

4.3.5.1 Using Front Panel Keys

You can use the keys in the DATA ENTRY keypad to enter numbers, units, and characters.



To enter a numeric value:

1. Select a numeric data input field to activate it.
2. Press the data entry keys.
 - Use [0] to [9] to enter the corresponding numbers.
 - Use [.] to enter a decimal point.

- Use [-] to change the sign of the value.
- Use [G/n], [M/μ], [k/m], or [x1] to multiply the entered value with factors of $10^{(-)9}$, $10^{(-)6}$, $10^{(-)3}$ or 1 and to add the appropriate physical unit.

To enter a character string:

1. Tap a character data input field to activate it.
2. Press the DATA ENTRY keys as if you were writing a short message on your mobile phone.
 - Use [0] to [9] to enter the corresponding numbers.
 - Use [.] and [-] to enter a dot or hyphen.
 - Use Use [G/n], [M/μ], or [k/m] to enter the letters G, M or K (case-insensitive).
 - Use the [←] key to correct wrong entries, deleting the character to the left of the current cursor position.
 - Press [ENTER] to complete an entry.
 - Press [ESC] to discard the entries made.
3. To enter letters other than G, M or K, you can also use one of the methods described in the following sections:
 - [Chapter 4.3.5.3, "Using the Analyzer's On-Screen Keyboard"](#), on page 53
 - [Chapter 4.3.5.4, "Using the Windows® On-Screen Keyboard"](#), on page 53

4.3.5.2 Using the Numeric Editor

The "Numeric Editor" is a tool for convenient entry and modification of numeric values. It is available for all numeric input fields in the analyzer GUI.

Operation with touchscreen or mouse:

1. Double-tap (double-click) a numeric input field in a dialog or on a softtool to open the numeric editor.

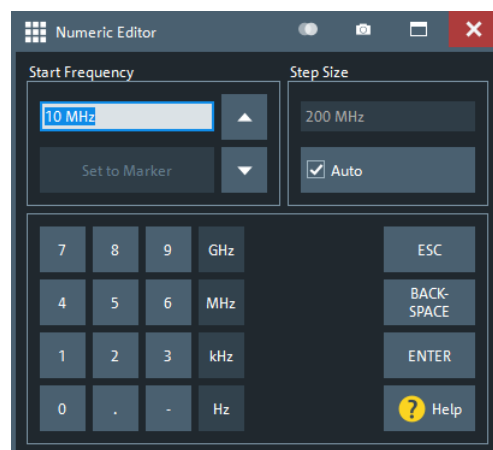

2. Use the buttons in the numeric keypad to compose the numeric input value.

3. If desired, select a "Step Size" and use the cursor up/down buttons to increment/decrement the current value. If a marker is active, you can also set the numeric value to the current marker value ("Set to Marker").
4. After completing the input string, select "ENTER" to apply your selection and close the numeric editor.



[STEP SIZE] key

If a numeric input field is active, the [STEP SIZE] front panel key opens a dialog box containing the "Step Size" panel of the numeric editor. Use this box for efficient operation of the rotary knob (and mouse wheel).

4.3.5.3 Using the Analyzer's On-Screen Keyboard

The on-screen "Keyboard" allows you to enter characters, in particular letters, without an external keyboard. It is available for all text input fields in the analyzer GUI.

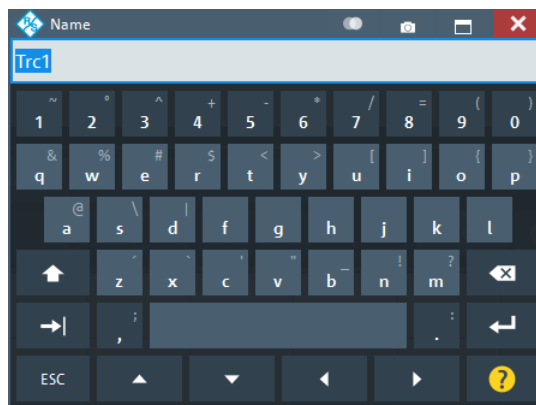

1. Activate a character data input field in a softtool or a dialog.
2. Double-tap/click the input field to open the on-screen keyboard.
3. Select character buttons to compose the input string.
4. Select "Enter" to apply your selection and close the keyboard.

4.3.5.4 Using the Windows® On-Screen Keyboard

The Windows® on-screen keyboard allows you to enter characters, in particular letters, even if an input field cannot call up the analyzer's own on-screen keyboard. Examples are input fields in standard Windows® dialogs.

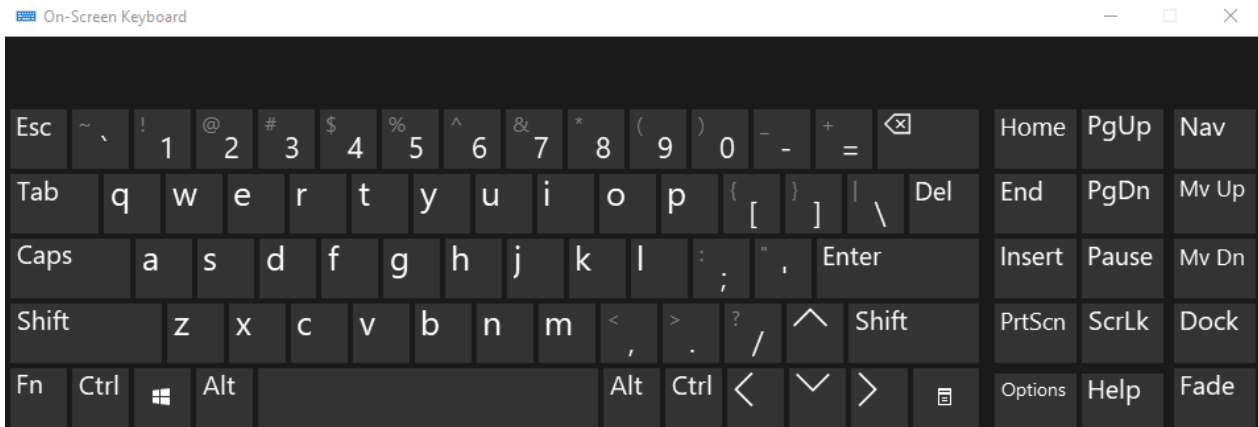

Figure 4-6: Windows 10 on-screen keyboard

To call up the on-screen keyboard:

1. Open the SYSTEM – [APPLIC] softtool.
2. In the "External Tools" tab, select "Screen Keyboard".

4.3.6 Scaling Diagrams

The analyzer provides various tools for customizing the diagrams and for setting the sweep range. Choose the method that is most convenient for you.

4.3.6.1 Using the Graphical Zoom

The graphical zoom function magnifies a rectangular portion of the diagram (zoom window) to fill the entire diagram area. The sweep points are not affected.



The graphical zoom function is only supported for cartesian trace formats. For (inverted) Smith and polar diagrams, it is not available.



To activate the graphical zoom:

- Select the "Zoom Config" icon in the toolbar above the diagram area and make sure that the graphical zoom mode is active:

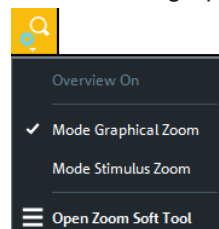

- Select the "Zoom Select" toggle button in the toolbar above the diagram area.



The icon changes its background color from black to blue.

- In the active diagram area, select an appropriate rectangular area.

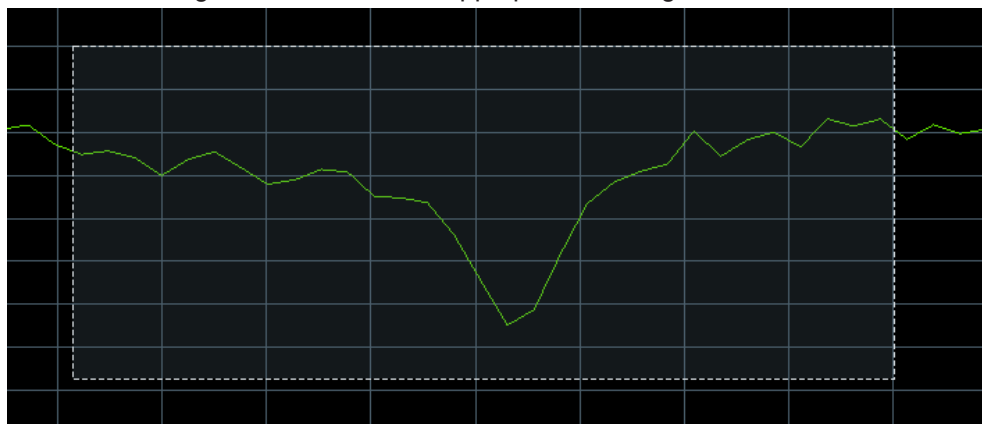

The zoomed view shows the selected rectangle, scaled in both horizontal and vertical direction. In general, the zoom window covers only a part of the sweep range; the horizontal distance between the sweep points increases. The reduced display range is indicated in an additional zoom line in the channel info area.

Ch1	Start	1 GHz	Pwr	-10 dBm	Stop	6 GHz
	Start	3.92 GHz	Zoom	Trc1	Stop	5.96 GHz



Use the "Zoom Reset" icon to restore the original diagram. Alternatively, you can drag and drop the "Zoom" label from the additional channel info line onto the  toolbar button.



Alternative settings

- The TRACE – [SCALE] > "Zoom" softtool tab allows you to define the displayed zoom range numerically. It can also be opened from the menu of the "Zoom Config" toolbar icon.
- If the active diagram is graphically zoomed, "Overview On" in the "Zoom" softtool tab toggles an overview. The upper part of the diagram then shows a small version of the unzoomed diagram. You can move the zoomed part of the trace by moving the rectangular area in the overview.

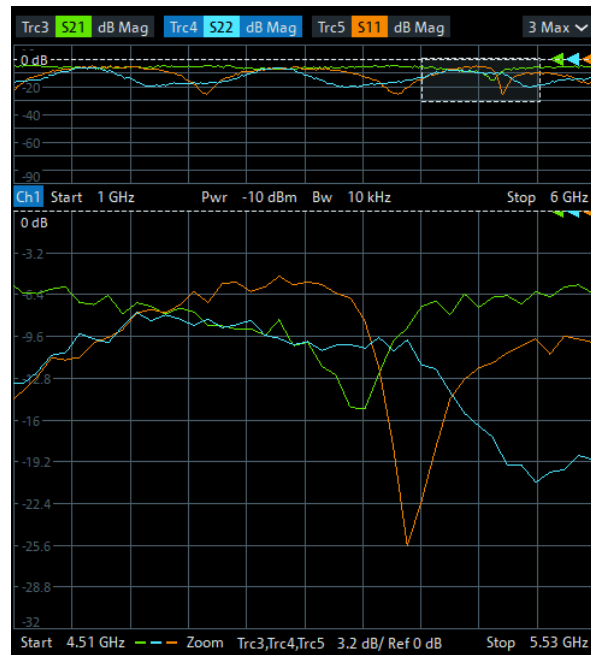

- To zoom the stimulus range (keeping the number of sweep points constant), use the "Zoom Config" toolbar icon and select "Mode Stimulus Zoom". Then use the "Zoom Select" icon to narrow the sweep range and adjust the vertical scaling.

Refer to the R&S ZND Help or User Manual for details.

4.3.6.2 Setting the Sweep Range

The sweep range for all related channels is displayed in the channel info area at the bottom of each diagram:

Ch1	Start	10 MHz	Pwr	-10 dBm	Bw	10 kHz	Stop	4 GHz
Ch2	Start	1 GHz	Pwr	-10 dBm	Bw	10 kHz	Stop	6 GHz
Ch3	Start	5 GHz	Pwr	-10 dBm	Bw	10 kHz	Stop	8.5 GHz
Trc4	Start	-1 ns	Time Domain				Stop	4 ns

To change the sweep range of the active channel, use one of the following methods:

- Use the [START], [STOP], [CENTER], and [SPAN] function keys from the STIMULUS section.
- Double-tap (with a mouse: double-click) the "Start" or "Stop" label in the channel list.

- Tap and hold (with a mouse: right-click) the "Start" or "Stop" label in the channel list and select "Start Frequency", "Stop Frequency", "Center Frequency", or "Frequency Span" from the context menu.
- Select "Start Frequency", "Stop Frequency", "Center Frequency", "Span Frequency" from the "Channel" > "Stimulus" menu.
- Use the "Set by Marker" functions (TRACE – [MARKER] > "Set by Marker"; see [Chapter 4.3.6.6, "Set by Marker"](#), on page 58).

4.3.6.3 Reference Value and Position

The analyzer provides three parameters for changing the scale of the vertical (response) axis:

- Changing the "Ref Value" or "Ref Pos" shifts the trace in vertical direction and adjusts the labels of the vertical axis. "Ref Value" also works for radial diagrams.
- Changing the "Scale/Div" modifies the value of the vertical or radial diagram divisions and thus the entire range of response values displayed.

The "Scale/Div" and the "Ref Value" are indicated in the scale section of the trace info. In the example below, a "Scale/Div" of 10 dB and a "Ref Value" of 0 dB is used.

Trc1 521 dB Mag 10 dB/ Ref 0 dB Math

To change such a scale parameter, use one of the following methods:

- Open the TRACE – [SCALE] > "Scale Values" softtool tab and proceed from there.
- Tap and hold (with a mouse: right-click) the scale section in the trace info and select a setting from the context menu.
- Select a setting from the "Trace" > "Scale" menu.
- Use "Set by Marker" functions (TRACE – [MARKER] > "Set by Marker"; see [Chapter 4.3.6.6, "Set by Marker"](#), on page 58).

4.3.6.4 Auto Scale

The "Auto Scale" function adjusts the scale divisions and the reference value so that the entire trace fits into the diagram. To access "Auto Scale", use one of the following methods:

- Open the TRACE – [SCALE] > "Scale Values" softtool tab and select "Auto Scale Trace" or "Auto Scale Diagram".
- Tap and hold (with a mouse: right-click) the scale section in the trace info and select "Auto Scale Trace" from the context menu.
- Select "Auto Scale Trace" or "Auto Scale Diagram" from the "Trace" > "Scale" menu.

4.3.6.5 Circular Diagrams

The radial scale of a circular diagram ("Polar", "Smith" or "Inverted Smith") can be changed with a single linear parameter, the "Ref Value". The reference value defines the radius of the outer circumference.

- Increasing the "Ref Value" scales down the polar diagram.
- Decreasing the "Ref Value" magnifies the polar diagram.

The "Ref Value" is indicated in the scale section of the trace info.

Trc1 S21 Polar 400 mU / Ref 2 U

To change the "Ref Value" setting, use one of the following methods:

- Locate it on the TRACE – [SCALE] > "Scale Values" softtool tab.
- Tap and hold (with a mouse: right-click) the scale section in the trace info and select the parameter from the context menu.
- Select the parameter from the "Trace" > "Scale" menu.
- Use the "Set by Marker" functions; see [Chapter 4.3.6.6, "Set by Marker"](#), on page 58.

4.3.6.6 Set by Marker

The "Set by Marker" functions are a convenient tool for scaling (in particular: magnifying) diagrams without entering explicit numeric values. You simply place a marker to a trace point and use the marker values to change the sweep range or move the trace relative to the vertical axis. The touchscreen or a mouse makes it easier to activate (touch/click) or move (drag and drop) markers.

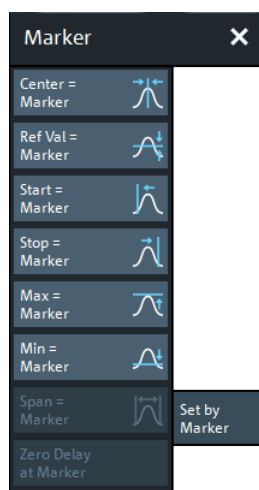

To set the sweep range using markers, use one of the following methods.

Set "Start" and "Stop" values in the diagram:

1. Create two normal markers, e.g. the markers "Mkr 1" (default label "M1") and "Mkr 2" (default label "M2").
See [Chapter 4.3.4.2, "Adding New Markers"](#), on page 49.

2. Place "M1" to the start value of the desired sweep range and tap TRACE – [MARKER] > "Set by Marker" > "Start = Marker".
3. Place "M2" to the stop value of the desired sweep range and tap TRACE – [MARKER] > "Set by Marker" > "Stop = Marker".

Use a definite "Span:"

1. Create a marker.
2. Enable "Delta Mode" for this marker.
The analyzer automatically creates an additional reference marker.
3. Place the reference marker to the start value of the desired sweep range.
4. Set the value of the delta marker to the desired sweep range and tap TRACE – [MARKER] > "Set by Marker" > "Span = Marker".

To move the trace in vertical direction, proceed as follows:

1. Create a normal marker, e.g. the marker "Mkr 1" (default label "M1").
2. Place "M1" to a particular trace point, e.g. use the "Marker Search" functions to locate a maximum or minimum on the trace.
3. Select TRACE – [MARKER] > "Set by Marker" > "Max = Marker" to move the trace towards the upper diagram edge, leaving the values of the vertical divisions ("Scale/Div") and the overall vertical scale unchanged. Analogously, select "Min = Marker" to move the trace towards the lower diagram edge, or select "Ref Val = Marker" to move the trace towards the "Ref Value".



You can also use marker values in the "Numeric Editor"; see [Chapter 4.3.5.2, "Using the Numeric Editor"](#), on page 52.

4.3.6.7 Enlarging a Diagram

The analyzer provides different tools for customizing the contents and size of the diagrams:

- Select  from the toolbar to maximize the active diagram. Or, equivalently, select SYSTEM – [DISPLAY] > "Diagram" > "Maximize Diagram".
If enabled the active diagram is always maximized.
- The "Menu Bar", the "Status Bar", the "Hard Key Panel", and the "Title Bar" can be hidden to gain space for the diagrams (SYSTEM – [DISPLAY] > "View Bar").
- The SYSTEM – [DISPLAY] > "Config" softtool tab defines optional display elements for the interior of the diagrams.

Use the context menu of the diagram, the SYSTEM – [DISPLAY] key or the "Display" menu to access the display settings.

4.4 Performing Measurements

This chapter takes you through a sample session with a R&S ZND network analyzer and describes basic operation tasks.

CAUTION

Safety considerations

Before starting any measurement on your network analyzer, please note the instructions given in [Chapter 4.1, "Putting the Analyzer into Operation"](#), on page 20.



Use the "S-Parameter Wizard" accessible via TRACE – [MEAS] > "S-Params" > "S-Param Wizard..." to measure S-parameters in a straightforward way. The wizard provides a series of dialogs where you can select the test setup, screen configuration and measurement parameters, configure the essential channel settings and perform a guided calibration.

Measurement stages in the wizard

The individual dialogs of the "S-Parameter Wizard" correspond to the typical stages of any measurement:

1. Select the test setup.
2. Define port impedances.
3. Select the measurement parameters and the diagrams.
4. Define the sweep range.
5. Adjust the receiver and source settings (measurement bandwidth, source power).
6. Perform a calibration.

4.4.1 Transmission S-Parameter Measurement

In a transmission measurement, the analyzer transmits a stimulus signal to the input port of the device under test (DUT) and measures the transmitted wave at the DUT's output port. The trace settings allow you to select the measured quantities and display formats, depending on what you want to learn from the data. A minimum of two analyzer test ports are required for transmission measurements.

In the following example, the analyzer is set up for a two-port transmission measurement. A frequency sweep range is selected, the instrument is calibrated and the measurement result is analyzed using various display formats.

4.4.1.1 Connecting the Instrument for Transmission Measurements

To prepare a transmission measurement, you have to connect your DUT (which for simplicity we assume to have appropriate connectors) in-between a pair of analyzer

test ports. It is recommended that you preset the R&S ZND to start from a well-defined instrument state.

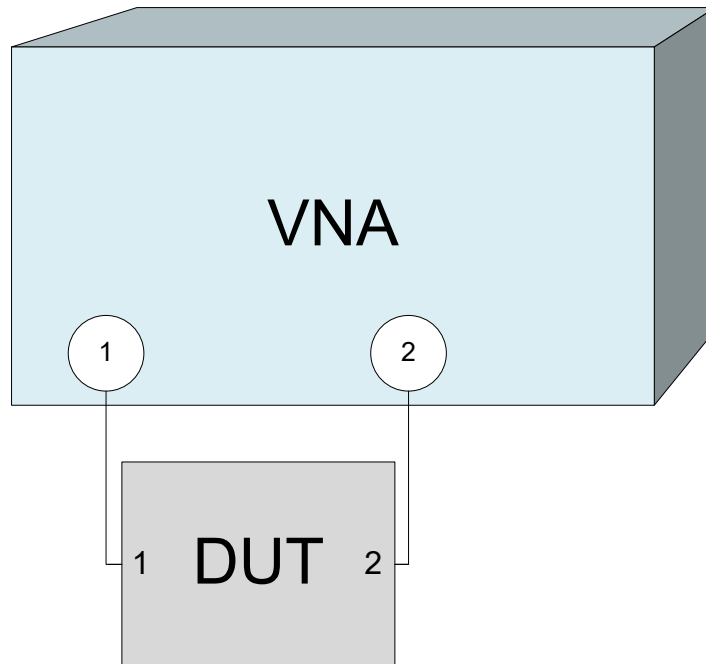

1. Connect the DUT between test ports 1 and 2 of the network analyzer as shown above.
2. Switch on the instrument and start the VNA application.
Proceed as described in [Chapter 4.1.7, "Starting the Analyzer and Shutting Down"](#), on page 23.
3. Use the [PRESET] key to restore a well-defined instrument state.
The analyzer is now set to its default state. The default measured quantity is the transmission S-parameter S_{21} .

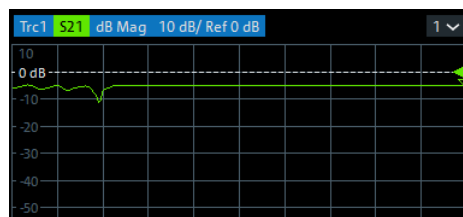

Select TRACE – [TRACE CONFIG] and use the control elements in the "Traces" soft-tool tab if you wish to create additional traces and diagrams.

4.4.1.2 Selecting the Sweep Range and Other Parameters

After a system preset the display shows a diagram with a dB magnitude scale, and the S-parameter S_{21} is selected as a measured quantity. This S-parameter is the forward

transmission coefficient of the DUT. It is defined as the ratio of the transmitted wave at the DUT's output port (port no. 2) to the incident wave at the DUT's input port (port no. 1).

The R&S ZND automatically adjusts its internal source and receiver to the selected measured quantities: For an S_{21} measurement, a stimulus signal (termed a_1) is transmitted at the analyzer port no. 1; the transmitted wave (termed b_2) is measured at port 2. The stimulus signal from the analyzer port no. 2 is not needed except for some calibration types.

By default the sweep range is set to the frequency range of the analyzer, which can be unsuitable for your DUT. The following procedure shows you how to configure a smaller sweep range.

1. Select STIMULUS – [START] and set the "Start Frequency" to the lowest frequency you want to measure (e.g. 1.77 GHz). For convenient numeric entry, open the "Numeric Editor" (see [Chapter 4.3.5.2, "Using the Numeric Editor"](#), on page 52).

Tip: If you use the DATA ENTRY keys at the front panel for data entry, type [1][.][7][7] and terminate the entry with the [G/n] key.

Refer to [Chapter 4.3.5, "Entering Data"](#), on page 51 to learn more about entering numeric values and characters.

2. In the "Stop Frequency" input field, enter the highest frequency you want to measure (e.g. 2.5 GHz).
3. Select TRACE – [SCALE] > "Scale Values" and activate the "Auto Scale Trace" function. The analyzer adjusts the scale of the diagram to fit in the entire S_{21} trace, leaving an appropriate display margin.

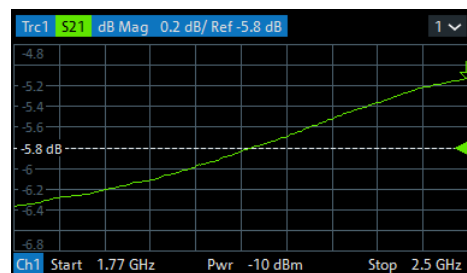

Tip: Refer to [Chapter 4.3.6, "Scaling Diagrams"](#), on page 54 to learn more about the different methods and tools for diagram scaling.

4.4.1.3 Calibrating the Instrument

Calibration (system error correction) is the process of eliminating systematic, reproducible errors from the measurement results. E.g., in the current test setup, the connecting cables between the analyzer ports and the DUT introduce an attenuation and a phase shift of the waves. Both effects impair the accuracy of the S-parameter measurement.

The analyzer provides a wide range of sophisticated calibration methods for all types of measurements. The calibration method to select depends on the expected system errors, the accuracy requirements of the measurement, on the test setup and on the types of calibration standards available.

The following example requires a calibration kit with a male Through standard with known transmission characteristics for the related test port connector type and gender. With a single Through, it is possible to perform a transmission normalization, compensating for a frequency-dependent attenuation and phase shift in the signal paths.

Due to the R&S ZND's calibration wizard, calibration is a straightforward, guided process.

1. Replace the DUT by the Through standard of your calibration kit. Make sure to disconnect all calibration units.
2. Select CHANNEL – [CAL] > "Start... (Manual)" to open the "Calibration Setting" wizard.
3. Select the port combination Port 1 (P1) and Port 2 (P2) and the calibration type "Trans Norm". Make sure to define port 1 as the source port.

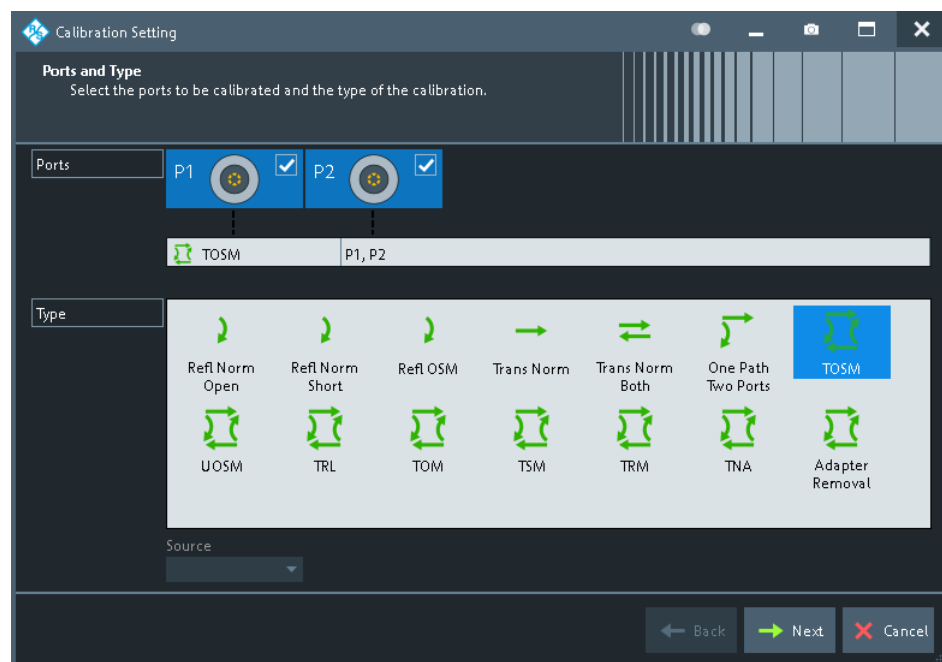

Tip: For a unidirectional R&S ZND, only port 1 can be the source port. Hence calibrations that require both ports as driving port are not available.

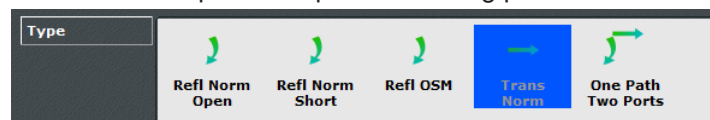

4. Select "Next" to proceed to the next page of the "Calibration Setting" wizard.

- Select the test port connector type and gender (here: N 50 Ω , female, corresponding to a male Through standard), and the calibration kit (here: R&S ZV-Z121).

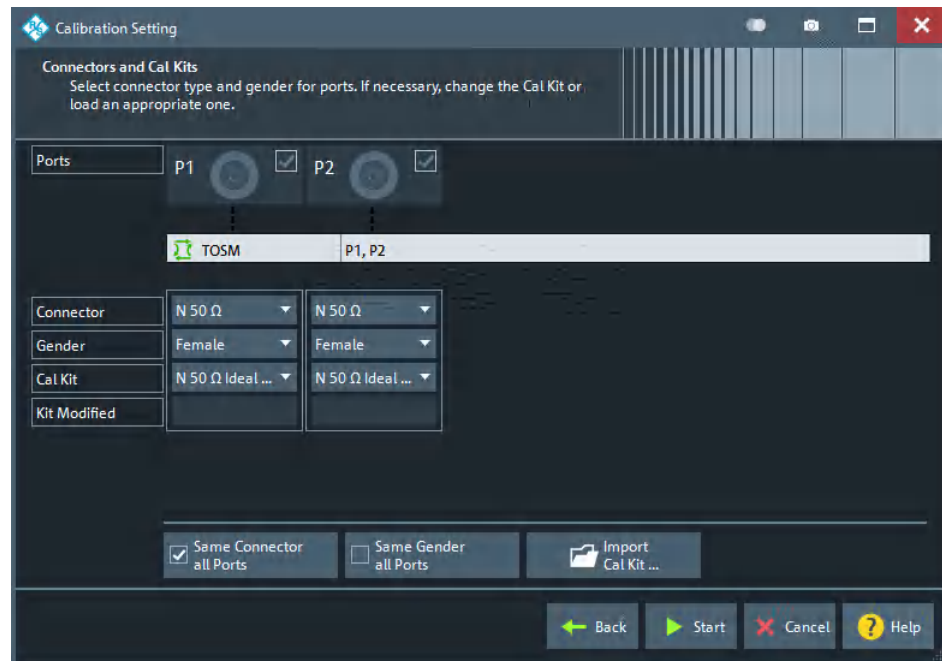

- Tap "Start".
- The calibration dock widget indicates the standard measurements that make up a "Trans Norm" calibration. Select "Through (mm)" to initiate the measurement of the connected Through standard. Measuring the isolation between ports 1 and 2 is optional. Skip it for now.



The analyzer performs a calibration sweep for the measured quantity S_{21} . The magnitude and phase of the result is displayed in two diagrams, together with the expected typical result for a Through standard. The similarity of real and expected traces indicates that the Through standard has been properly connected. After the R&S ZND has completed the calibration sweep and calculated the correction data, the "Apply" button is enabled.

8. Select "Apply" to close the wizard.

The system error correction is calculated and applied to the current channel. A "Cal" label appears in the trace list.

To proceed with the measurement, remove the Through standard and connect the DUT again.

4.4.1.4 Evaluating Data

The analyzer provides various tools to optimize the display and analyze the measurement data. For instance, you can use markers to determine maxima and minima on the trace, and change the display format to obtain information about the group delay of the transmitted wave.

1. Select TRACE – [MARKER] > "Markers" > "Mkr 1".

This places marker "M1" to its default position (center of the sweep range). A marker symbol (triangle) appears on the trace, a marker info field in the upper right corner of the diagram. The marker info field displays the stimulus value (frequency) and response value (magnitude of the transmission coefficient converted to a dB value) at the marker position.

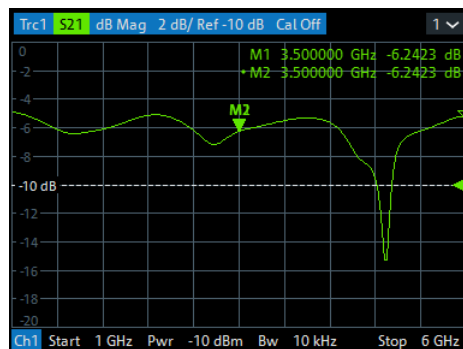

2. Select TRACE – [MARKER], activate the "Marker Search" softtool tab and activate "Min" search.
The marker jumps to the absolute minimum of the curve in the entire sweep range. The marker info field shows the coordinates of the new marker position.
3. Select TRACE – [FORMAT] and choose the "Delay" of the transmission coefficient as displayed quantity.

The group delay represents the propagation time of the wave through the DUT; it is displayed in a Cartesian diagram. The marker info field shows the frequency and group delay at the marker position.

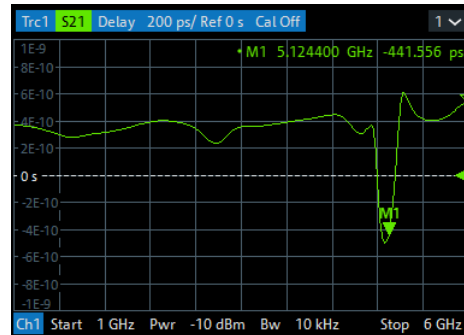

Refer to [Chapter 5.2.3, "Trace Formats"](#), on page 95 to learn more about the diagram properties.

4.4.1.5 Saving and Printing Data

The analyzer provides standard functions for saving measurement settings and for saving or printing the results. You can use these functions as if you were working on a standard PC. Moreover you can export your trace data to an ASCII file and reuse it in a later session or in an external application.



Data transfer is made easier if external accessories are connected to the analyzer or if the instrument is integrated into a LAN. Refer to [Chapter 4.1.9, "Connecting External Accessories"](#), on page 24, and [Chapter 11.1.3, "Remote Operation in a LAN"](#), on page 1150 to obtain information about the necessary steps.

1. Activate the SYSTEM – [FILE] > "Trace Data" softtool tab.
2. In the "Trace Data" softtool tab, select "Export" – "ASCII..." to open the "Export Data - ASCII Files" dialog.
3. In the "Export Data - ASCII Files" dialog:
 - a) Select a file location ("Look in:").
 - b) Enter a file name ("File name:").
 - c) Select "Save".

The analyzer writes the data of the active trace to an ASCII file and closes the dialog.

4. Activate the "Print" softtool tab (SYSTEM – [FILE] > "Print") .
5. In the "Print" softtool tab, select "Print" to print the diagram area or "To Clipboard" to copy it to the Windows clipboard.
6. Select SYSTEM – [FILE] > "Recall Sets" > "Save..." to open the "Save" dialog for recall sets.

7. In the "Save" dialog:
 - a) Select a file location ("Look in:").
 - b) Enter a name for the recall set file ("File name:").
 - c) Select "Save".

The analyzer saves the active recall set, containing channel, stimulus and trace settings, to a `znx` file. This recall set can be restored in a later session.

4.4.2 Reflection S-Parameter Measurement

In a reflection measurement, the analyzer transmits a stimulus signal to the input port of the device under test (DUT) and measures the reflected wave. Different trace formats allow you to express and display the results, depending on what you want to learn from the data. Only one analyzer test port is required for reflection measurements.

In principle, a reflection measurement involves the same steps as a transmission measurement. Note the following differences:

- The basic test setup for reflection measurements involves a single DUT and analyzer port. For instance, you can connect the input of your DUT to port 1 of the analyzer as shown below.

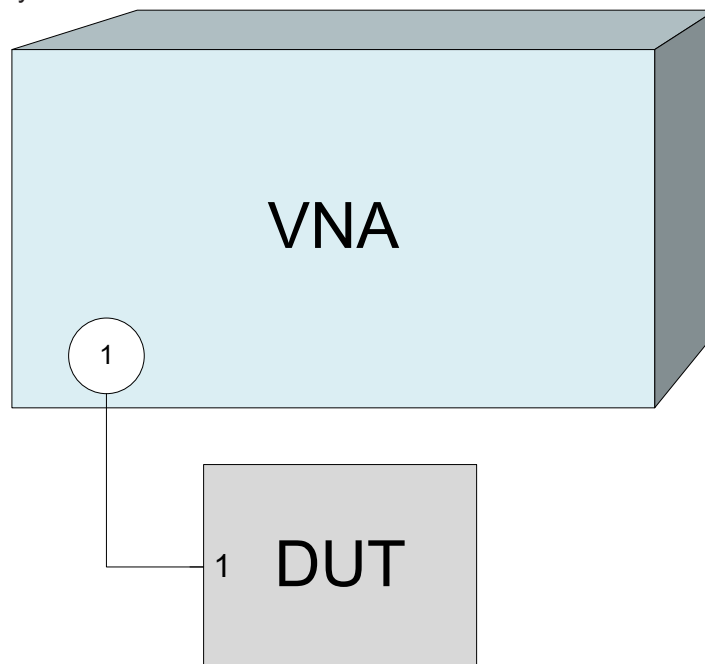

You can also use the basic transmission test setup, e.g. if you want to measure reflection and transmission parameters in parallel.

- The analyzer provides special calibration types for reflection measurements. Use the calibration wizard and select an appropriate type. A full 2-port calibration (TOSM, UOSM, TNA ...) corrects the system errors for all transmission and reflection S-parameters.

- Some of the trace formats are particularly suited for reflection measurements. For instance, you can display the measured reflection coefficient S_{11} in a Smith chart to obtain the complex input impedance at port 1.

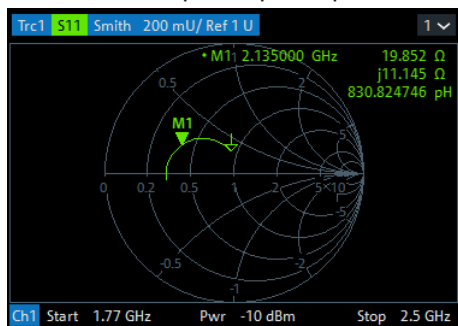

Proceed as described in [Chapter 4.1.7, "Starting the Analyzer and Shutting Down"](#), on page 23 to shut down your analyzer.

5 Concepts and Features

The following chapter provides an overview of the analyzer's capabilities and their use. It contains a description of the basic concepts that the analyzer uses to organize, process and display measurement data. Also included are descriptions of the screen contents, possible measured quantities, calibration methods and typical test setups.

For a systematic explanation of all softtools, functions and parameters refer to [Chapter 6, "GUI Reference"](#), on page 219.

5.1 Basic Concepts

The analyzer provides various functions to perform a particular measurement and to customize and optimize the evaluation of results. To ensure that the instrument resources are easily accessible and that user-defined configurations can be conveniently implemented, stored and reused, the instrument uses a hierarchy of structures:

- Global resources can be used for all measurements, irrespective of the current measurement session.
- A recall set comprises a set of diagrams together with the underlying system, channel, trace and display settings. It can be saved to a recall set file and later recalled.
- The diagrams show traces which are assigned to channels. See [Chapter 5.1.3, "Traces, Channels and Diagrams"](#), on page 70.

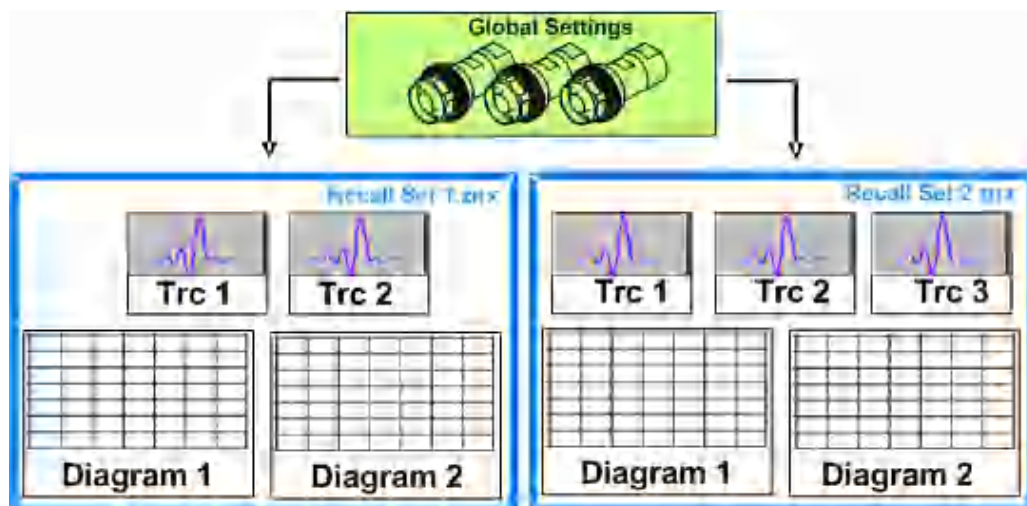

5.1.1 Global (Persistent) Settings

The analyzer manages global settings that apply to all measurements, irrespective of the current measurement setup. The following list contains examples of global settings:

- Calibration kits
- Connector types

- Cal pool data including system error correction and power correction data
- Directories for trace data, limit lines, calibration data etc.
- Color schemes and printer settings
- System configurations, to be accessed via SYSTEM – [SETUP].
- External power meter and switch matrix configurations

Global settings are not part of a recall set nor are they affected by a [PRESET] of the analyzer. Many of them can be "Reset" in the "System Config" dialog.

Some settings are session-specific, i.e. they are initialized to default when a new measurement session is started (session settings).

5.1.2 Recall Sets

A recall set comprises a set of diagrams together with the underlying system, channel, trace and display settings. The R&S ZND can handle multiple recall sets in parallel, each of them displayed in a separate tab.



A recall set can be saved to a recall set file (*.znx|*.znxml) and reopened at a later point in time or at another instrument. Use the "Recall Sets" tab of the SYSTEM – [FILE] softtool to organize recall sets.



A recall set only contains setup instructions, i.e. information on how to measure, how to process the measurement results, and how to display the processed results. It does **not** contain any trace or result data.

5.1.3 Traces, Channels and Diagrams

The analyzer arranges, displays or stores the measured data in traces which are assigned to channels and displayed in diagrams. To understand the functions of the instrument and quickly find the appropriate settings, it is important to understand the exact meaning of the three terms.

- A trace is a set of data points that can be displayed together in a diagram. The trace settings specify the mathematical operations used to obtain traces from the measured or stored data and to display them.
- A channel contains hardware-related settings which specify how the network analyzer collects data.
- A diagram is a rectangular portion of the screen which is used to display traces. Diagrams belonging to the same recall set are arranged in a common tab. The settings for diagrams are described in [Chapter 5.2.1, "Display Elements of a Diagram"](#), on page 81.

A diagram can contain a practically unlimited number of traces, assigned to different channels. Diagrams and channels are independent from each other.

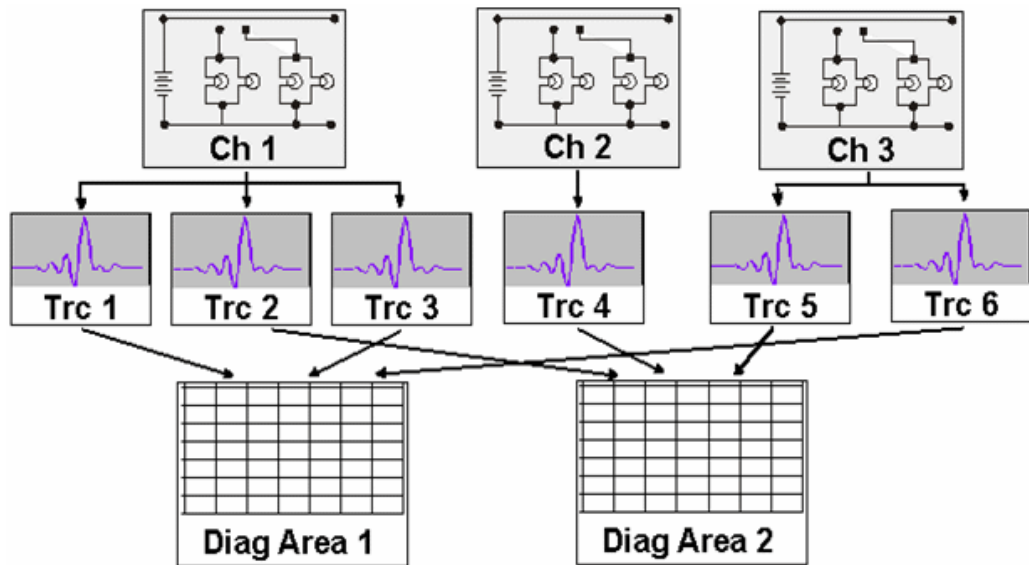

5.1.3.1 Trace Settings

The trace settings specify the mathematical operations used to obtain traces from the measured or stored data. They can be divided into several main groups:

- Selection of the measured quantity (S-parameters, wave quantities, ratios, impedances,...)
- Conversion into the appropriate display format and selection of the diagram type
- Scaling of the diagram and selection of the traces associated to the same channel
- Readout and search of particular values on the trace by means of markers
- Limit check

The trace settings can be accessed via the keys in the TRACE section of the (virtual) hardkey panel. They complement the [Channel Settings](#) accessible via the STIMULUS and CHANNEL sections.

Each trace is assigned to a channel. The channel settings apply to all traces of the channel.

5.1.3.2 Channel Settings

A channel contains hardware-related settings which specify how the network analyzer collects data. The channel settings can be divided into three main groups:

- Description of the test setup (power of the internal source, IF filter bandwidth, port configuration, ...)
- Control of the measurement process (sweep, trigger, averaging, ...)
- Correction data (calibration, offset, ...)

The channel settings can be accessed via the STIMULUS and CHANNEL sections of the (virtual) hardkey panel.

5.1.3.3 Active and Inactive Traces and Channels

A window can display several diagrams simultaneously, each with a variable number of traces. One of these traces is active at each time. The **active trace** is highlighted in the trace list on top of the active diagram (Trc4 in the figure below):

Trc1	S11	Smith	200 mU/ Ref 1 U	Trc2	S12	dB Mag	10 dB/ Ref 0 dB	1
Trc3	S21	dB Mag	10 dB/ Ref 0 dB	Trc4	S22	Smith	200 mU/ Ref 1 U	

When a trace is selected in the diagram area, it becomes the **active trace**. If a previously inactive area is selected as the active area, the trace that was active last time when the area was active again becomes the active trace.

The **active channel** is the channel which belongs to the active trace. The channels of all traces in a diagram are listed at the bottom of the diagram, together with the "Stimulus" values and the display colors of all traces. The active channel is highlighted.

Ch1	Start	5 kHz	Pwr	-10 dBm	Bw	10 kHz	Stop	6 GHz
Ch2	Freq	1 GHz	Pwr	-10 dBm	Bw	10 kHz	Stop	201
Ch3	Freq	1 GHz	Pwr	-10 dBm	Bw	10 kHz	Stop	1 s
Ch4	Start	5 kHz	Pwr	-10 dBm	Bw	10 kHz	Stop	6 GHz
Trc4	Start	-1 ns	Time	Domain			Stop	4 ns

Channels with no traces are not indicated in the diagrams but can be accessed via the "Channel Manager" dialog.



In manual control, there is always exactly one active trace, irrespective of the number of channels and traces defined. In remote control, each channel contains an active trace.

See also [Chapter 7.3, "Basic Remote Control Concepts"](#), on page 572.

5.1.4 Sweep Control

A sweep is a series of consecutive measurements taken over a specified sequence of stimulus values. It represents the basic measurement cycle of the analyzer.

The analyzer can perform:

- sweeps at constant power but variable frequency (frequency sweeps)
- sweeps at constant frequency but variable power (power sweeps)
- sweeps at constant power and frequency that are repeated in time (Time/CW Mode sweeps)

The sweeps are further specified by the number of measurement points and the total measurement time.

By default, sweeps are repeated continuously. Alternatively, a measurement can also consist of a single sweep or of a specified number of sweeps.



After changing the channel settings or selecting another measured quantity, the analyzer needs some time to initialize the new sweep. This preparation period increases with the number of points and the number of partial measurements involved. It is indicated in the status bar:

Ch1: Avg None **Preparing** 3/20/2018 10:31:16 AM

All analyzer settings can still be changed during sweep initialization. If necessary, the analyzer terminates the current initialization and starts a new preparation period.

During the first sweep after a change of the channel settings, the analyzer displays an asterisk symbol in the status bar.

Ch1: Avg None ★ Ch1 P2 **40%** 3/20/2018 10:30:57 AM

5.1.4.1 Partial Measurements and Driving Mode

Depending on the measurement task and the measured quantities, the measurement at each sweep point can consist of one or several "partial measurements" with definite hardware settings.

- If a single S-parameter is measured (e.g. the reflection coefficient S_{11}), the analyzer can operate at fixed hardware settings. In particular, a fixed source port and receive port is used. Each sweep point requires a single partial measurement. See also [Chapter 5.3.1, "S-Parameters"](#), on page 104.
- For a complete two-port S-parameter measurement (e.g. S_{11} , S_{21} , S_{12} , S_{22}) the analyzer needs to interchange the roles of the source and receive ports. Each sweep point requires two partial measurements.

To improve the accuracy, it is possible to insert a delay time before each partial measurement.



To use port 2 of a R&S ZND as driving port, you need the suitable "bidirectional measurements" option [R&S ZND-K5](#) or [R&S ZND-K6](#).

In the default "**Alternated**" driving mode, the R&S ZND performs a partial measurement at all sweep points (partial sweep) before the hardware settings are changed. The next partial measurement is carried out in an additional sweep. In the "**Chopped**" driving mode, the order is reversed, i.e. the measurement proceeds sweep point per sweep point, with varying hardware settings.

See CHANNEL – [CHANNEL CONFIG] > "Mode" > "Driving Mode".

Advantages of alternated and chopped driving mode

If the settling time between sweep points is smaller than the settling time between hardware settings (which is generally true), then the "Alternated" mode is faster than the "Chopped" mode. On the other hand, the "Chopped" mode builds up traces sweep point per sweep point, whereas in the "Alternated" mode you have to wait for the last partial sweep.



Use the "Alternated" mode to increase the accuracy of measurements on DUTs with long level settling times (e.g. quartzes, SAW filters). To measure DUTs with short settling times and obtain a trace from the beginning of the sweep, use "Chopped" mode. In "Auto" mode, the analyzer optimizes the display update: Fast sweeps are performed in "Alternated" mode, slower sweeps in "Chopped" mode.

As an alternative to activating the "Alternated" mode, it is possible to insert a measurement delay before each partial measurement and thus improve the accuracy.

See CHANNEL – [SWEEP] > "Sweep Params" > "Meas Delay".

However, the delay slows down the measurement.

Relation to trigger settings

In triggered measurements, "Alternated" and "Block Alternated" have no effect, if the triggered measurement sequence is identical to a single sweep point. The following table shows how the analyzer performs a sweep comprising m sweep points, assuming that each of them requires n partial measurements.

Triggered Meas. Sequence	"Alternated" mode	"Chopped" mode
Sweep	Trigger event starts n partial sweeps over all sweep points.	Trigger event starts m complete measurements at consecutive sweep points.
Sweep Segment	Trigger event starts n partial sweeps over the next segment.	Trigger event starts complete measurements at all consecutive sweep points in the segment.
Point	All partial measurements of each sweep point are carried out one after another.	All partial measurements of each sweep point are carried out one after another.
Partial Measurement	Each partial measurement is carried out for all sweep points.	All partial measurements of each sweep point are carried out one after another

Block Alternated driving mode

The "Block Alternated" driving mode that was introduced in firmware version 3.30, allows you to split the sweep range into several (~ equally sized) blocks of sweep points. The measurement proceeds block per block, using the "Alternated" driving mode for each block.

If two or more partial measurements are required, you can minimize the overall sweep duration by selecting a suitable number of blocks.

5.1.4.2 Pipelining of Measurement Data

In the legacy implementation of the alternated driving mode, the next sweep begins when all trace data from the previous sweep has been processed.

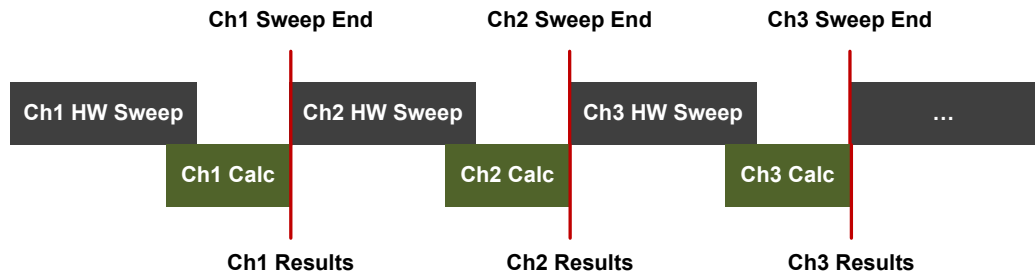

Figure 5-1: Legacy sweep implementation (no pipelining)

For each sweep, trace data processing is triggered when the first data of the last partial measurement arrives.

With pipelining, the next sweep can already start when the raw measurement data of the previous sweep has been distributed completely. The calculation of the previous sweep is processed in parallel to the next one, which effectively eliminates hardware idle time during sweeps.

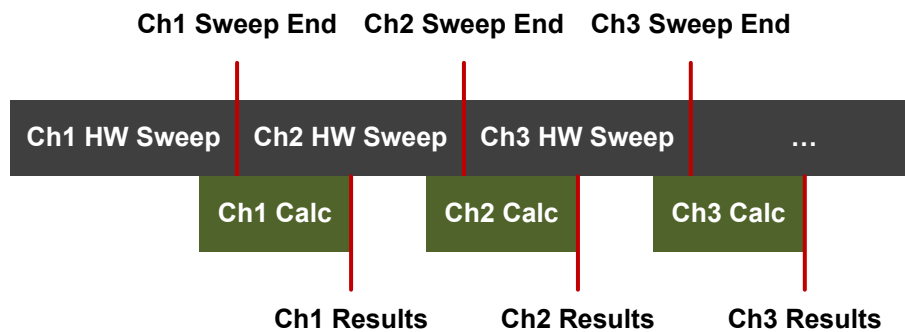

Figure 5-2: Pipelining

In the current implementation ("setup-based pipelining"), calculations are synchronized to the end of the sweep sequence: when all channels of the active setup are swept, the firmware waits until all data has been calculated before starting the next sweep sequence.

With active pipelining, "the measurement result" (e.g. a pass/fail) will be available when the next measurement is already running. Depending on the measurement scenario, also a pipelined DUT handling can be necessary. For example, a device handler has to provide a parking position for a DUT until the decision to skip or forward it is made.



The described optimization is only available for the alternated driving mode.

5.1.4.3 R&S ZND: Unidirectional vs. Bidirectional Operation

To use port 2 of a R&S ZND as driving port, you need one of the "bidirectional measurements" options R&S ZND-K5 (for a R&S ZND without the "extended frequency range" option R&S ZND-K1) or R&S ZND-K6 (for a R&S ZND with R&S ZND-K1).

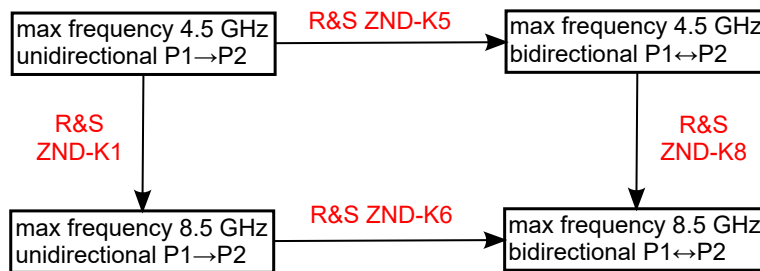

With unidirectional operation, the following restrictions apply:

- S12, S22 and wave quantities of the reverse direction (port 2 as source) are not available
- Other (derived) results that require driving both ports, such as Y- and Z-parameters or stability parameters, are not available
- Balanced mode is not available
- Calibrations that require driving both ports are not available (see [Chapter 5.5.1, "Calibration Types"](#), on page 141)
- Cal kit characterizations cannot be performed
- Only automatic spur avoidance is possible

5.1.4.4 Stimulus and Sweep Types

The function of the STIMULUS hardkeys [START], [STOP], [CENTER] and [SPAN] depends on the sweep type.

Table 5-1: Function of STIMULUS keys

Sweep type	[START](unit)	[STOP] (unit)	[CENTER] (unit)	[SPAN] (unit)
"Lin Freq"	"Start Frequency" (Hz)	"Stop Frequency" (Hz)	"Center Frequency" (Hz)	"Span Frequency" (Hz)
"Log Freq"	"Start Frequency" (Hz)	"Stop Frequency" (Hz)	–	–
"Segmented"	–	–	–	–
"Power"	"Start Power" (dBm)	"Stop Power" (dBm)	"CW Frequency" (Hz)	"CW Frequency" (Hz)
"CW Mode"	"CW Frequency" (Hz)	"Number of Points" (-)	"CW Frequency" (Hz)	"CW Frequency" (Hz)
"Time"	"CW Frequency" (Hz)	"Stop Time" (s)	"CW Frequency" (Hz)	"CW Frequency" (Hz)

The ranges of numerical values must be compatible with the instrument model. The conditions for the stimulus range depend on the sweep type:

- **"Lin Freq" / "Log Freq" / "Segmented"**
The supported frequency range is listed in [Table 8-15](#).
 - For "Lin Freq" and "Log Freq" sweeps, if the number of sweep points is greater than 1, the stop frequency must be greater than the start frequency and the span must be ≥ 1 Hz. If a stop frequency smaller or equal than the current start frequency is set, then the start frequency is adjusted and vice versa.

- For "Segmented" sweeps, the start and stop frequency in a sweep segment must not be different. So with a segmented sweep you can measure n_1 points at frequency f_1 (in segment 1), n_2 points at frequency f_2 (in segment 2) etc.
- **"Power"**
Start and stop power are both entered in absolute units (dBm). Start and stop power must be different; the stop power must be larger than the start power. If a stop power smaller than the start power is set, then the start power is adjusted automatically and vice versa.
The power corresponds to the actual source power at the test ports (channel base power P_b). After a port power calibration, this source power is available at the calibrated reference plane.
- **"CW Mode"**
The stimulus hardkeys define the fixed stimulus frequency ("CW Frequency") and the "Number of Points" of the measurement. The other sweep parameters (e.g. the "Sweep Time") are set via CHANNEL – [SWEEP] > "Sweep Params".
- **"Time"**
The stimulus hardkeys define the fixed stimulus frequency ("CW Frequency") and the total sweep time ("Stop Time") of the measurement. The other sweep parameters (e.g. the "Number of Points") are set via CHANNEL – [SWEEP] > "Sweep Params".
The sweep time is entered in seconds and must be positive.



The selected sweep range applies to all source and receive ports of the analyzer.

5.1.5 Data Flow

The analyzer processes the raw measurement data in a sequence of stages to obtain the displayed trace. The following subsections give an overview.

5.1.5.1 Channel Data Flow

The diagram below illustrates the data processing stages for the entire channel. All stages are configurable.

Note that the channel data flow for S-parameters (and quantities derived from S-parameters such as impedances, admittances, stability factors) differs from the channel data flow for wave quantities (and derived quantities such as ratios).

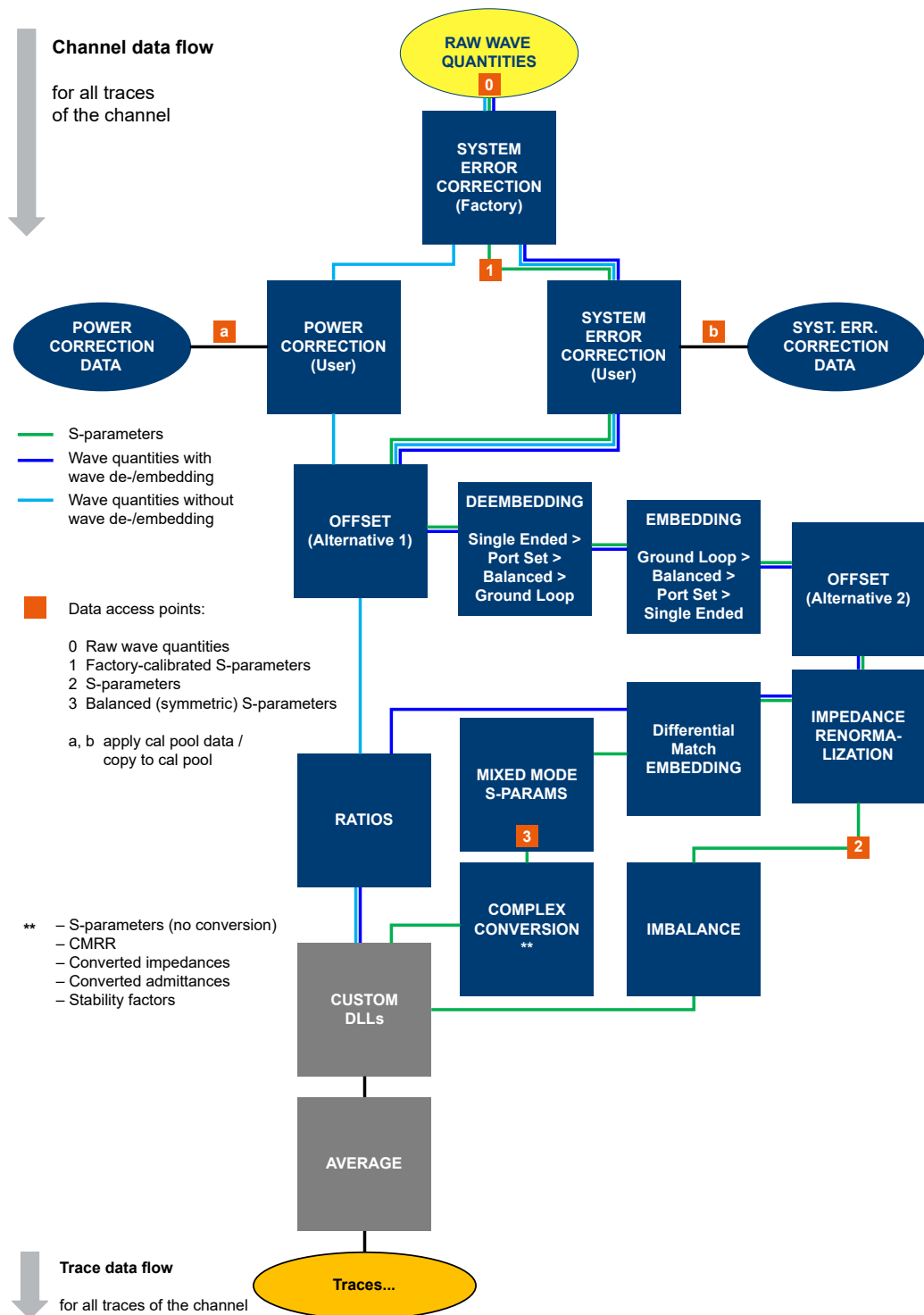

Figure 5-3: Channel data flow

Wave de-/embedding

In its original implementation, de-/embedding was calculated on the S-parameter branch of the channel calculation chain. After applying factory calibration and/or user

calibration on the measured wave quantities, intermediate results were transformed to the S-parameter domain. Before each **de-/embedding** step, the S-parameters were transformed to conductance (~ wave quantities), and vice versa afterwards.

The new "wave de-/embedding" remains in the wave quantity (~conductance) domain and calculates all de-/embedding steps in one multiplication step, without unnecessary matrix inversions. With "wave de-/embedding", the computation time does not depend on the number of embedding and/or de-embedding steps but is constant.

5.1.5.2 Trace Data Flow

The diagram below illustrates the processing stages the channel measurement data run through for each individual trace. Again, all stages are configurable.

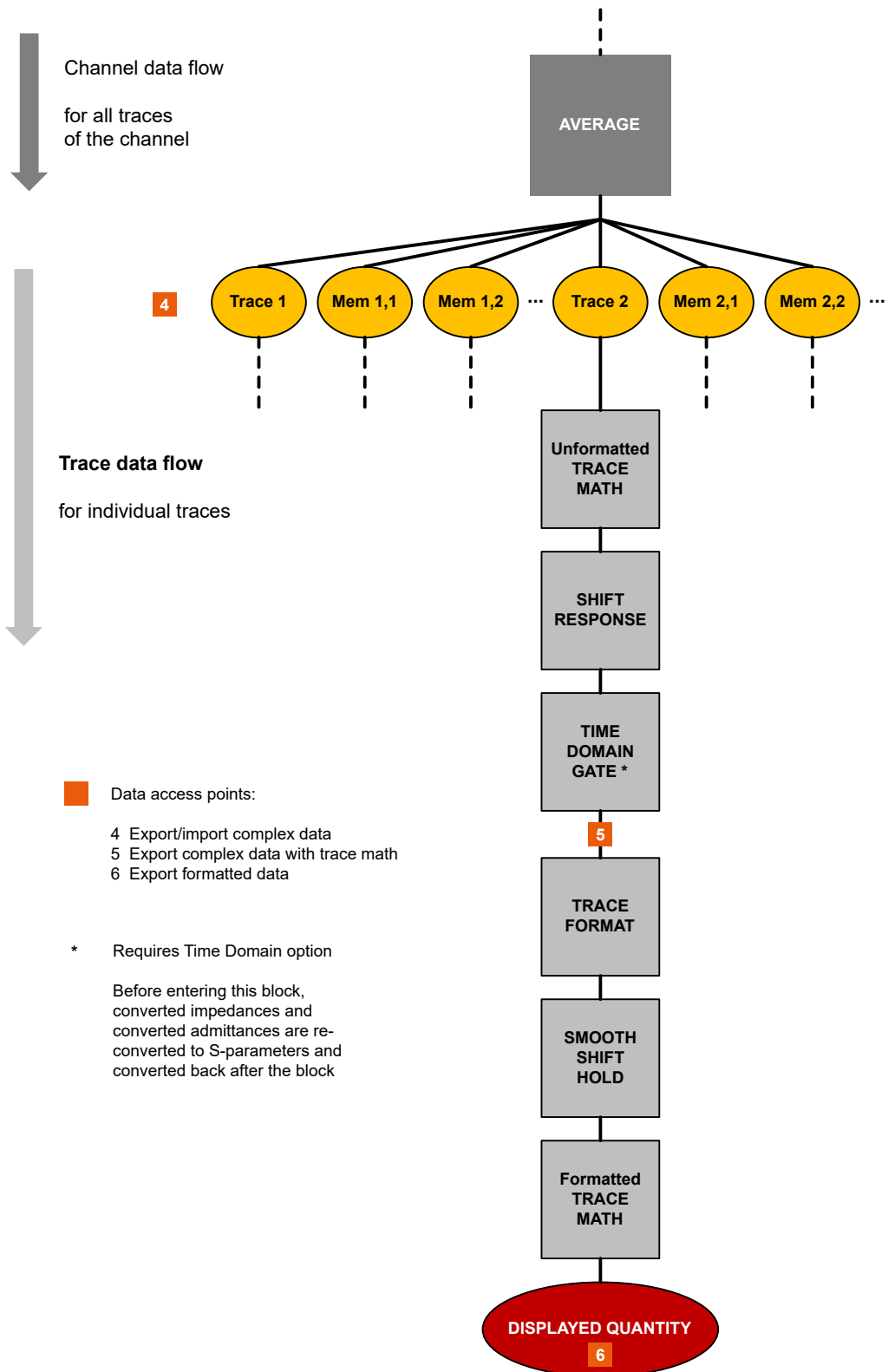

5.2 Screen Elements

This section describes manual operation of the analyzer, including trace settings, markers and diagrams. For a description of the different quantities measured by the instrument, refer to [Chapter 5.3, "Measurement Results"](#), on page 103.

5.2.1 Display Elements of a Diagram

The central part of the screen is occupied by one or more diagrams.

A diagram is simply a rectangular portion of the screen used to display traces. Diagrams are independent of trace and channel settings. A diagram can contain a practically unlimited number of traces which can be assigned to different channels.

Most diagram settings are arranged in the "Display" softtool (hardkey SYSTEM – [DISPLAY]). To assign traces and channels to diagrams, use the control elements on the "Trace Config" > "Traces" and "Channel Config" > "Channels" softtool tabs (hardkeys TRACE – [TRACE CONFIG] and CHANNEL – [CHANNEL CONFIG]).

Diagrams can contain:

- A title (optional)
- The diagram number (or label)
- Measurement results, in particular traces and marker values (optional)
- An indication of the basic channel and trace settings
- Context menus providing settings which are related to a particular display element
- Error messages



The examples in this section have been taken from Cartesian diagrams. All other diagram types provide the same display elements.

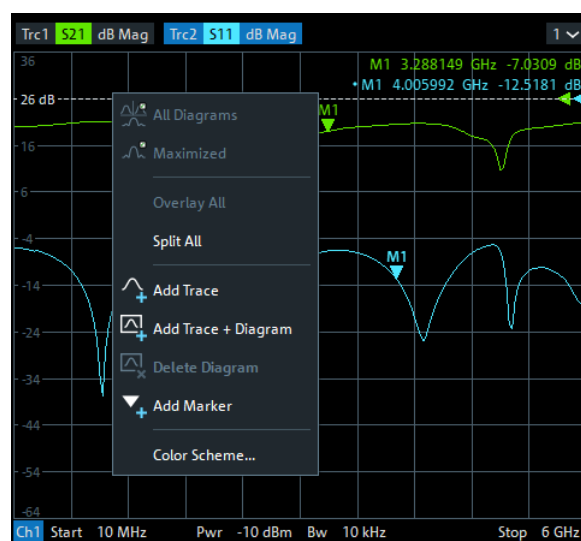

5.2.1.1 Title

An optional title across the top of the diagram can be used for a brief description of the diagram contents.

5-Parameter Measurement



Select SYSTEM – [DISPLAY] > "Diagram" > "Title" to enter the diagram title and "Show Title" to display or hide it.

5.2.1.2 Traces

A trace is a set of data points displayed together in the diagram. The individual data points are connected so that each trace forms a continuous line.

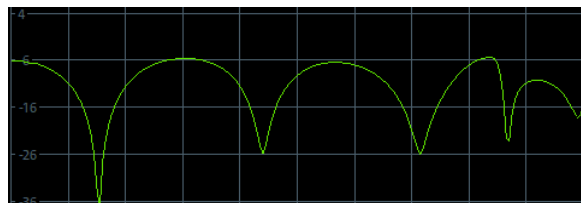

The trace can be complemented by the following display elements, plotted with the same color:

- Reference value (for all traces): The reference value is indicated with a triangle at the right edge of the diagram and a dashed, horizontal line. The value and position of the triangle can be changed to modify the diagram scale and shift the trace vertically.
- Measured quantity (for the active trace): The measured quantity is indicated in the trace list; see ["Trace List and Trace Settings"](#) on page 83.

A trace can be either a data trace, a memory trace, or a mathematical trace; see ["Trace Types"](#) on page 82.

Trace Types

The analyzer uses traces to display the current measurement result in a diagram. It is also capable of storing traces to the memory, recalling stored traces, and defining mathematical relations between different traces. There are three basic trace types:

- Data traces show the current measurement data and are continuously updated as the measurement goes on. Data traces are dynamic traces.
- Memory traces are generated by storing the data trace to the memory. They represent the state of the data trace at the moment when it was stored. Memory traces are static traces which can be stored to a file and recalled.
- Mathematical traces are calculated according to a mathematical relation between constants and the data or memory traces of the active recall set. A mathematical trace that is based on the active data trace is dynamic.

It is possible to generate an unlimited number of memory traces from a data trace and display them together. Markers and marker functions are available for all trace types.



The type of each trace in a diagram is indicated in the trace list: "MEM<no>" at the beginning of the trace name indicates a memory trace (with default naming), Math at the end of the trace label indicates a mathematical trace. You can also hide a trace ("Invisible") without deleting it.

Trc1	S11	dB Mag	10 dB/ Ref 0 dB	Ch1	Math	Mem5[Trc1]	S11	dB Mag	10 dB/ Ref 0 dB	Ch1
Trc5	S21	dB Mag	10 dB/ Ref 0 dB	Ch2	Invisible					

Trace List and Trace Settings

The main properties of all traces assigned to the diagram are displayed in the trace list in the upper part of the diagram.

Trc1	S11	dB Mag	10 dB/ Ref 0 dB	Ch1	Math	Mem5[Trc1]	S11	dB Mag	10 dB/ Ref 0 dB	Ch1
Trc5	S21	dB Mag	10 dB/ Ref 0 dB	Ch2	Invisible					

Each line in the trace list describes a single trace. The active trace is highlighted ("Trc5" in the example above). The lines are divided into several sections with the following contents (from left to right):

- The **trace name** appears in the first section. The default names for new traces are Trc<n> with n automatically selected. A "Mem..." at the beginning of the trace name indicates a memory trace (default naming). To change the trace names, open the "Trace Manager" from any trace name segment's context menu.
- The **measured quantity** (e.g. an S-parameter or a ratio) appears on a colored background. The source port for wave quantities and ratios is indicated in brackets.
- The **format** section shows how the measured data is presented in the graphical display. Use the context menu of the format section to change the format of the related trace.
- The next sections show the value of the vertical or radial diagram divisions ("Scale Div.") and the reference value ("Ref").
- The **channel** section shows the channel that each trace is assigned to. It is omitted if the all traces in the diagram are assigned to the same channel.
- The **type** section indicates "Invisible" if a trace is hidden and Math if the trace is a mathematical trace. "Gat" indicates that a time gate is active for the trace. Use the "Mem Math" and "Traces" tabs of the "Trace Config" softtool to display and hide data and memory traces, and to define mathematical traces.



- The respective section's context menu (except for the type section) provides access to the most common related tasks.
- If the size of the diagram is too small, some of the sections are hidden. Enlarge or maximize the diagram to display all sections.

Example:

The following context menu is assigned to the measured quantity section in the trace list:

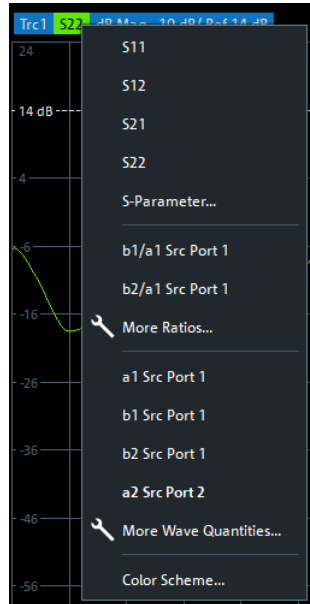

A label "Cal Off" appears at the end of the trace line if the system error correction no longer applies to the trace.

5.2.1.3 Markers

Markers are tools for numerical readout of measured data and for selecting points on the trace, or, in general, in the diagram area. A marker is displayed with a symbol (e.g. a triangle, a crossbar or a line) on the trace, which can be a data trace or a memory trace. At the same time, the coordinates are displayed in a marker info field or in a table. Each marker can be defined as a normal marker (M), reference marker (R), or delta marker (Δ M).

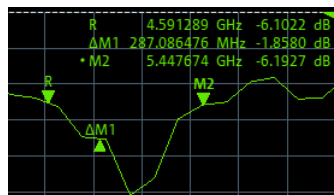

- A normal marker ("M1, M2...") determines the coordinates of a measurement point on the trace.
- The reference marker ("R") defines the reference value for all delta markers.
- A delta marker ("DeltaM1, DeltaM2...") indicates the coordinates relative to the reference marker.

A special set of markers M1 to M4 is provided for bandfilter search mode.

The most common tasks to be performed with markers can be achieved using the "Marker" menu functions:

- Determine the coordinates of a measurement point on the trace. In polar diagrams where no x-axis is displayed, markers can be used to retrieve the stimulus value of specific points.
- Determine the difference between two trace points or the relative measurement result ("Delta Mode").
- Convert a complex measurement result into other formats.

Markers also play an important role in performing the following advanced tasks:

- Change the sweep range and the diagram scale ("Marker Function").
- Search for specific points on the trace ("Marker Search", "Target Search", "Bandfilter").

Activating and Moving Markers

To activate a marker, either select the marker symbol itself or the corresponding line in the marker info field.

To move the active marker on the trace, use one of the following methods:

- Drag the marker symbol to the desired position (Cartesian diagrams only).
- Activate the "Markers" tab of the "Marker" softtool (TRACE – [MARKER]) and enter the related stimulus value numerically.
- Use the functions on the "Marker Search" softtool tab to move the marker to a specific position.



If the marker position is adjusted using the roll key, the mouse or the cursor keys, it always remains within the sweep range. If set explicitly by entering a numeric value, the marker position can be outside the sweep range. In this case, the marker symbol is automatically positioned to the start or stop value of the sweep range, whichever is closer.

Marker Info Field

The coordinates of all markers defined in a diagram can be displayed in the info field, which by default is located in the upper right corner.

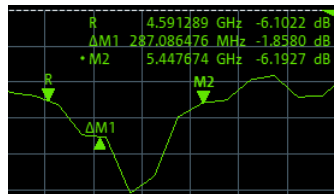

The info field contains the following information:

- "M1, M2..." denote the marker numbers. Markers are displayed with the same color as the associated trace.
- The marker coordinates are expressed in one of the marker formats selected via TRACE – [MARKER] > "Marker Props" > "Marker Format". The formats of the

markers assigned to a trace are independent of each other and of the trace format settings.

- The active marker has a dot placed in front of the marker line.
- "R" denotes the reference marker. A "Δ" sign placed in front of the marker line indicates that the marker is in delta mode.

Open the context menu of the marker info field to access frequently used marker settings.



Customizing the marker info field

To change the position, appearance or contents of the marker info field, use one of the following methods:

- The info field can be moved to several positions in the upper and lower part of the active diagram. Drag & drop it to the desired position.
- To change the format of the active marker, select [TRACE] > "Marker" > "Marker Properties" > "Marker Format".
- To express the coordinates of the active marker relative to the reference marker, activate the delta mode [TRACE] > "Marker" > "Marker Properties" > "Delta Mode".



Info Table

If you wish to reserve the full diagram space for traces, you can drag & drop the marker info field to the info table.

M1	Trc1	5.130001	GHz	-15.6388	dB	Bandstop	Trc1	Ref to Max	Track
M2	Trc1	4.718891	GHz	-7.3323	dB	Bandwidth		535.657892	MHz
M3	Trc1	5.254549	GHz	-7.3323	dB	Center		4.979523	GHz
M4	Trc1	4.979523	GHz	-9.5924	dB	Lower Edge		4.718891	GHz
						Upper Edge		5.254549	GHz
						Quality Factor (3dB)		9.296	U
						Loss		15.6388	dB

The info table is hidden by default. To display it, open the "Display" softtool (SYSTEM – [DISPLAY]), activate its "Config" tab and select "Info Table" – "Show".

Marker Format

Marker values can be formatted according to the current trace format, according to the default marker format of the related trace (TRACE > [FORMAT] > "Format" > "Dflt Marker Frmt"), or formatted individually (TRACE > [MARKER] > "Marker Props" > "Marker Format").

The available marker formats are defined for all measured quantities and trace formats (see [Chapter 5.2.3.3, "Measured Quantities and Trace Formats"](#), on page 103). Essentially, a marker format is simply a conversion between points on a complex-valued

trace (the raw measurement data) and the respective target format. This must be kept in mind when interpreting the results and physical units displayed.

The following table describes how a complex marker value $z = x + jy$ is converted. It makes use of the polar representation $z = x + jy = |z| e^{j\varphi(z)}$, where

$$|z| = (x^2 + y^2)^{1/2} \text{ and } \varphi(z) = \arctan(y/x)$$

Table 5-2: Marker formats

Marker Format	Description	Formula
Default	<ul style="list-style-type: none"> For an individual marker, this means that the marker is formatted according to the default marker format of the related trace. For a trace's default marker format, this means that the default format is (dynamically) adjusted according to the selected trace format. 	–
Lin Mag	Magnitude of z, unconverted	$ z = \sqrt{x^2 + y^2}$
dB Mag	Magnitude of z in dB	$ z = \sqrt{x^2 + y^2}$ dB Mag(z) = $20 * \log z $ dB
Phase	Phase of z	$\varphi(z) = \arctan(y/x)$
Delay	Group delay, neg. derivative of the phase response ¹⁾	$-\frac{d\varphi(z)}{d\omega}$, where ω denotes the stimulus frequency
Real	Real part of z	$\text{Re}(z) = x$
Imag	Imaginary part of z	$\text{Im}(z) = y$
SWR	(Voltage) Standing Wave Ratio	$\text{SWR} = (1 + z) / (1 - z)$
dB Mag Phase	Magnitude of z in dB and phase in two lines	$20 * \log z $ dB $\arctan(\text{Im}(z) / \text{Re}(z))$
Lin Mag Phase	Magnitude of z (unconverted) and phase in two lines	$ z \arctan(\text{Im}(z) / \text{Re}(z))$
Real Imag	Real and imaginary part of z in two lines	x y
R + j X or R + j X series ^{***)}	(Series) impedance: Unnormalized (series) resistance, reactance, and either inductance or capacitance, in three lines (Smith diagram)	R_s X_s L_s or C_s ^{***)}
R + j X parallel ^{***)}	Parallel impedance: Unnormalized parallel resistance, reactance, and either inductance or capacitance, in three lines (Smith diagram)	R_p X_p L_p or C_p ^{***)}
G + j B or G + j B series ^{***)}	(Series) admittance: Unnormalized (series) conductance, susceptance, and either inductance or capacitance, in three lines (Inverted Smith diagram)	G_s B_s L_s or C_s ^{***)}
G + j B parallel ^{***)}	Parallel admittance: Unnormalized parallel conductance, susceptance, and either inductance or capacitance in three lines (Inverted Smith diagram)	G_p B_p L_p or C_p ^{***)}

Marker Format	Description	Formula
Imp Mag or IMP Mag series***)	Magnitude of (series) impedance**)	$ Z_s = (R_s^2 + X_s^2)^{1/2}$
Imp Mag paral- lel***)	Magnitude of parallel impedance**)	$ Z_p = (R_p^2 + X_p^2)^{1/2}$
Adm Mag or Adm Mag series***)	Magnitude of (series) admittance**)	$ Y_s = (G_s^2 + B_s^2)^{1/2}$
Adm Mag paral- lel***)	Magnitude of parallel admittance**)	$ Y_p = (G_p^2 + B_p^2)^{1/2}$
Index	Index of the current sweep point	–

*) The delay aperture is defined in the [TRACE CONFIG] > "Format" softtool.

**) An impedance Z is represented as $Z = R + jX$, the corresponding admittance as $Y = 1/Z = G + jB$. For $X \geq 0$, we have an inductance $L = X/\omega$, for $X < 0$ we have a capacitance $C = 1/(\omega X)$, where ω denotes the stimulus frequency.

***) Only available for transmission measurements (see [Chapter 5.3.3.1, "Converted Impedances"](#), on page 107)

Marker Coupling

It connects the markers of a set of traces.

Marker coupling allows you to compare different measurement results (assigned to different traces) at the same stimulus value. It connects the markers of a set of traces.

Marker coupling can be enabled:

- either for all traces in the active recall set that have the same stimulus variable as the active trace
- or for all traces in a channel
- or for all traces in a diagram that have the same stimulus variable as the active trace

When marker coupling is enabled, the same markers are activated for all related traces: if a marker was active for some related trace, then it is activated for all related traces.

While marker coupling is active, the marker sets of the related traces are always kept in sync, i.e.:

- If a marker is added to (removed from) one of the related traces, it is also added to (removed from) the other related traces.
- If a marker is moved to a particular stimulus value for one of the related traces, then it is moved to this stimulus value for all related traces.

If the new stimulus value is outside a trace's sweep range, the marker value is invalid for this trace. The corresponding info field only displays the stimulus value.



Only one kind of marker coupling can be enabled. For instance it is not possible to couple markers per channel and per diagram at the same time.

Basic Marker Search Functions

The search functions are tools for searching measurement data according to specific criteria. A search consists of analyzing the measurement points of the current trace (or of a user-defined subrange termed the "Search Range") to find one of the following:

- Absolute or relative (local) maxima and minima (peak search).
- Trace points with a specific response value (target search).
- Trace segments with a shape that is characteristic for bandpass or bandstop filters (bandfilter search); see "[Bandfilter Search](#)" on page 89.

When the search is activated, the active marker is moved to the (next) point that meets the search criteria. If the trace contains no markers, a marker M1 is created and used for the search. The search result is displayed in the marker info field. If no search result can be found, the marker remains at its original position.

Some search functions can be activated repeatedly to find all possible search results. Moreover the analyzer provides a "Tracking" mode where the search is repeated after each sweep.

Multiple Peak Search

Multiple peak search allows you to find multiple local minima/maxima at once. Markers 1 to 10 are assigned to the peaks detected from the start frequency towards the stop frequency. Multiple peak search uses its own search and tracking settings; search and tracking settings for standard marker search are ignored.

Bandfilter Search

In a bandfilter search, the R&S ZND locates trace segments with a bandpass or band-stop shape and determines characteristic filter parameters.

Bandpass and bandstop regions can be described with the same parameter set:

- A bandpass region contains a local maximum around which the magnitude of the trace falls off by more than a specified value.
- A bandstop region contains a local minimum around which the magnitude of the trace increases by more than a specified value.

The analyzer locates bandpass and bandstop regions and determines their position ("Center" frequency) and shape ("Bandwidth", "Lower Edge" and "Upper Edge", quality factor. For a meaningful definition of the bandwidth factor, the trace format must be "dB Mag".

Bandstop	Ref to Max	Track
Bandwidth	473.584123	MHz
Center	5.008818	GHz
Lower Edge	4.777620	GHz
Upper Edge	5.251205	GHz
Quality Factor (3dB)	10.576	U
Loss	14.9467	dB

The info field contains the following search results:

- "Bandwidth" is the n-dB bandwidth of the bandpass/bandstop region, where n is a selectable bandwidth factor. The bandwidth is equal to the difference between the lower and the upper band edge frequency.
- "Center" is calculated as the geometric or arithmetic mean of the lower band edge frequency f_{LBE} and the upper band edge frequency f_{UBE} :

$$f_{Center} = \sqrt{f_{LBE} * f_{UBE}} \quad (\text{geometric mean}) \text{ or}$$

$$f_{Center} = 1/2 (f_{LBE} + f_{UBE}) \quad (\text{arithmetic mean})$$
 The arithmetic mean is always higher than the geometric mean. The values are close if the bandwidth is small compared to the geometric mean of the band edges.
- "Lower Edge" is the closest frequency below the maximum (or minimum), where the trace value is equal to the maximum (minimum) value minus (plus) n dB.
- "Upper Edge" is the closest frequency above the maximum (or minimum), where the trace value is equal to the maximum (minimum) value minus (plus) n dB.
- The "Quality Factor (3 dB)" is the ratio between the "Center" frequency and the 3-dB "Bandwidth"; it does not depend on the selected bandwidth factor.
- The "Quality Factor (BW)" is the ratio between the "Center" frequency and the "Bandwidth" displayed above. This result is available only if the selected bandwidth factor is different from 3 dB.
- "Loss" is the loss of the filter at its maximum (or minimum) and is equal to the response value of marker no. 1. For an ideal bandpass filter, the loss is zero (0 dB), for an ideal bandstop filter it is $-\infty$ dB.

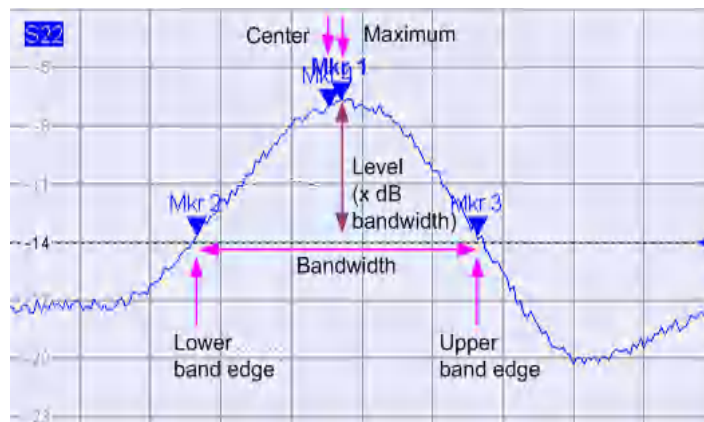

5.2.1.4 Channel List and Channel Settings

The main properties of all channels assigned to the traces in the diagram are displayed in the channel list below the diagram.

Ch1	Start	5 kHz	Pwr	-10 dBm	Bw	10 kHz	Stop	6 GHz
Ch2	Freq	1 GHz	Pwr	-10 dBm	Bw	10 kHz	Stop	201
Ch3	Freq	1 GHz	Pwr	-10 dBm	Bw	10 kHz	Stop	1 s
Ch4	Start	5 kHz	Pwr	-10 dBm	Bw	10 kHz	Stop	6 GHz
Trc4	Start	-1 ns	Time Domain				Stop	4 ns

Each line in the channel list describes a single channel. The channel of the active trace is highlighted. The lines are divided into several sections with the following contents (from left to right):

- The "Channel Name" appears in the first section. The default names for new channels are Ch<n> with an automatically assigned number <n>. If a time domain transform is active, the R&S ZND displays an additional line to indicate the stimulus range of the displayed time-domain trace.
Open the "Channel Manager" from the name segment's context menu to change the channel name.
- **Start** indicates the lowest value of the sweep variable (e.g. the lowest frequency measured), corresponding to the left edge of a Cartesian diagram.
- The **color legend** shows the display color of all traces assigned to the channel. The colors are different, so the number of colors is equal to the numbers of traces assigned to the channel.
- The values behind the color legend show the **constant stimulus value**, which is either the power of the internal signal source (for frequency sweeps and time sweeps) or the CW frequency (for power sweeps), and the measurement bandwidth ("BW").
- **Stop** indicates the highest value of the sweep variable (e.g. the highest frequency measured), corresponding to the right edge of a Cartesian diagram.



Open a segment's context menu to access common related tasks.

Example:

The following context menu is assigned to the channel name section:

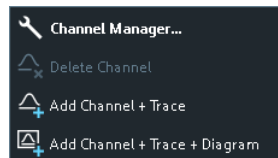

The settings in the context menus correspond to the most common functions in the CHANNEL – [CHANNEL CONFIG] > "Channels" softtool tab, the "Stimulus" softtool (opened via STIMULUS hardkeys), the CHANNEL – [SWEEP] > "Sweep Params" softtool tab, and the CHANNEL – [PWR BW AVG] softtool.

5.2.1.5 Context Menus

To provide access to the most common tasks and speed up the operation, the analyzer offers context menus (right-click menus) for the following display elements:

- Diagram
- Marker info field
- Trace list (separate context menus for trace name section, measured quantity section, format section, scale section, and channel section)

- Channel list (separate context menus for channel name section, sweep range section, additional parameter section)

To open a context menu associated with a display element, tap and hold the element for some seconds. Right-click the display element if you are using a mouse.

Example:

The following context menu is assigned to the channel name section in the channel list:

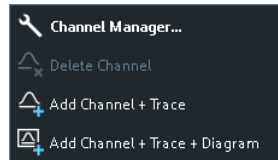

The functions of the context menu can also be called using the menu bar or the related softtool panels. Use whatever method is most convenient.

5.2.2 Dialogs

Dialogs provide groups of related settings and allow to make selections and enter data in an organized way. All softkeys with three dots behind their labeling (as in "Balanced Ports...") call up a dialog. The dialogs of the analyzer have an analogous structure and several common control elements.

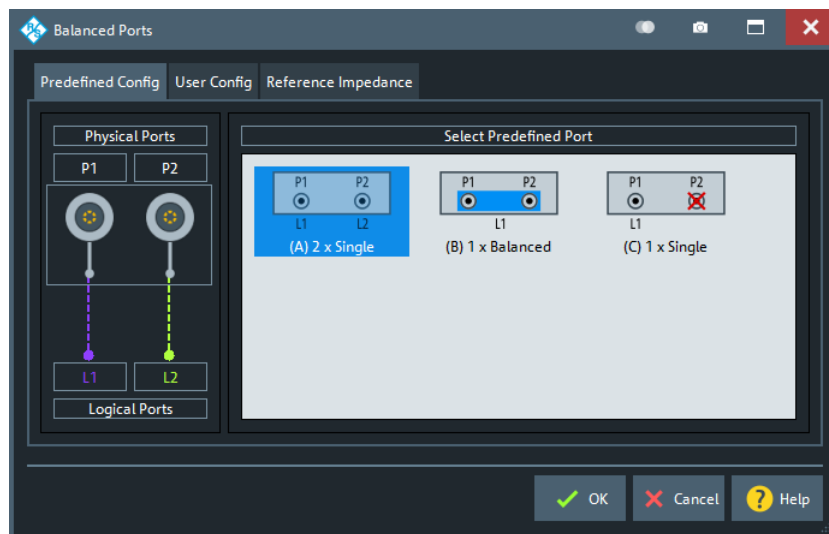

Dialogs are controlled in the usual way. For an introduction, refer to [Chapter 4.3.3, "Working with Dialogs"](#), on page 46.

5.2.2.1 Immediate vs. Confirmed Settings

In some dialogs settings take effect immediately, so that the effect on the measurement is observable while the dialog is still open. This behavior is particularly useful when a

numeric value is incremented or decremented, or when display elements are added or removed.

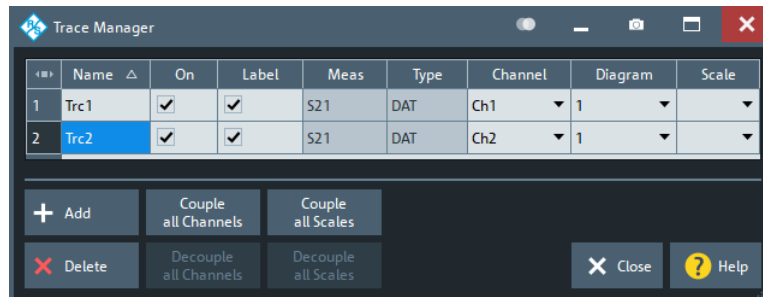

In most dialogs, however, it is possible to cancel an erroneous input before it takes effect. The settings in such dialogs must be confirmed explicitly.

The two types of dialogs are easy to distinguish:

- Dialogs with immediate settings provide a "Close" button but no "OK" button. Example: "Trace Manager" dialog
- Dialogs with confirmed settings provide both an "OK" button and a "Cancel" button. Example: "Balanced Ports" dialog



Immediate settings can be undone using [UNDO].

5.2.2.2 Common Dialogs

Open Dialog

The "Open File" dialog is used to open various file types (cal kit data, limit lines, sweep segment lists, ...).

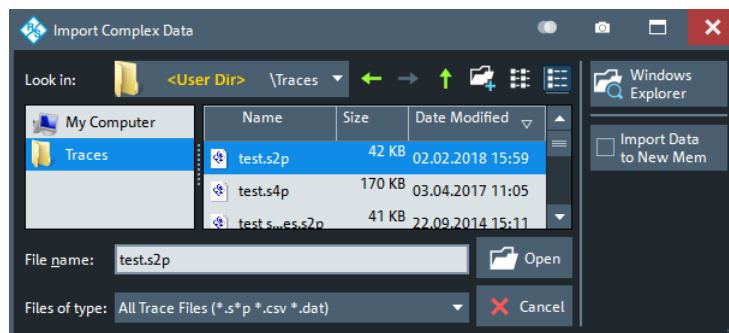

Depending on the context, the dialog is displayed with different caption, default directory ("Traces" in the above screenshot), and file type filters. Context-specific options ("Import Data to New Mem" in the above screenshot) are accessible via controls in the section below the "Windows Explorer" button.

- "Look in:" specifies the directory to be listed. The icons to the right of the pull-down list are provided for easy navigation in the file system (place the cursor on the icons to obtain "Whats this" help).

- "Windows Explorer" opens the selected directory in the Windows Explorer.
- "File name" specifies a filename to save the current data. The analyzer adds the extension in the "Files of type" field.
- "Files of type" filters the displayed files by type.
- "Open" opens selected file and closes the dialog.
- "Cancel" closes the dialog without opening a file.

Tip: Dialog properties (e.g. the current directory) are remembered when the dialog is closed. To restore default directories, select "Use Default Directories" in the [Presets Tab](#) of the "System Config" dialog.

Save Dialog

The "Save" dialog is used to store various data types (e.g. cal kit data, limit lines, sweep segment lists, ...).

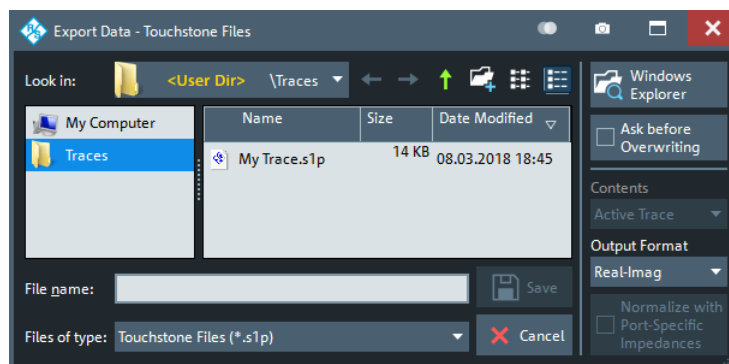

Depending on the context, the dialog is displayed with different caption, default directory ("Traces" in the above screenshot), and file types. Context-specific options (e.g. "Output Format" in the dialog above) are accessible via controls in the section below the "Ask Before Overwriting" toggle button.

- "Look in" specifies the drive and directory in which the data is stored. The icons to the right of the pull-down list are provided for easy navigation in the file system (place the cursor on the icons to obtain "Whats this" help).
- "File name" specifies a filename to save the current data. The analyzer adds the extension in the "Files of type" field.
- "Files of type" selects a particular file type for the created file.
- "Save" saves the data in the selected file and directory and closes the dialog.
- "Cancel" closes the dialog without saving the data.
- "Windows Explorer" opens the selected directory in Windows Explorer.
- If "Ask Before Overwriting" is enabled, overwriting an existing file has to be confirmed.

Tip: Dialog properties (e.g. the current directory) are remembered when the dialog is closed. To restore default directories, select "Use Default Directories" in the [Presets Tab](#) of the "System Config" dialog.

5.2.2.3 Multi-channel Setup Dialog

Depending on the desired DUT and measurement type, the measurement channel has to be prepared in a particular way. The multi-channel setup dialog was invented to make this task as easy as possible.

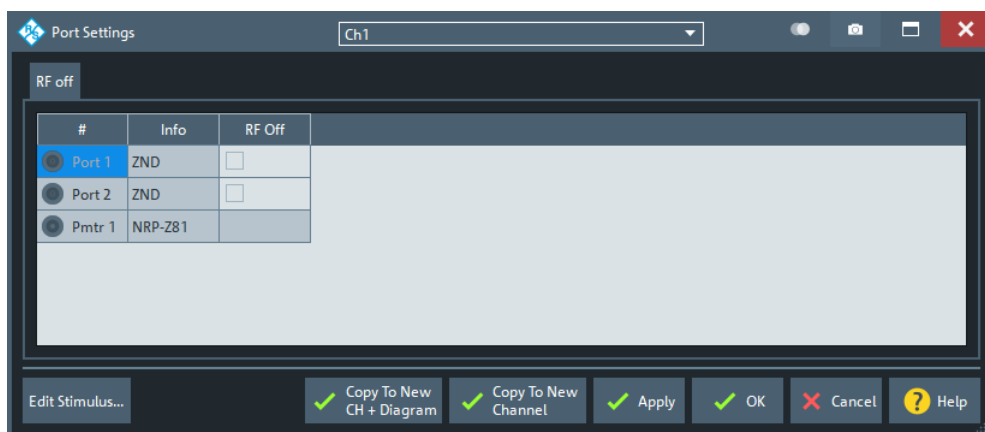

Figure 5-4: Multi-channel setup dialog

The channel selector in the title bar and the channel-related buttons in the lower part of the dialog ("Copy to New Channel", "Copy to New Ch + Diagram" allow you to select the target channels.

- On "OK", the channel selected in the title bar of the dialog is prepared for the measurement.
- Using "Copy to New Channel" or "Copy to New Ch + Diagram" it is possible create a channel and prepare the channel for the measurement in one go.

5.2.3 Trace Formats

A trace format defines how a trace is represented in a diagram.

The R&S ZND supports the following trace formats:

- **Cartesian Trace Formats** "dB Mag", "Phase", "SWR", "Unwr Phase", "Lin Mag", "Log Mag", "Real", "Imag" and "Delay".
- Complex trace formats "Polar", "Smith" and "Inv Smith"



The VNA firmware allows arbitrary combinations of trace formats and measured quantities. However, to extract useful information from the measured data, it is important to select a trace format which is appropriate for the analysis of a particular measured quantity; see [Chapter 5.2.3.3, "Measured Quantities and Trace Formats"](#), on page 103.

5.2.3.1 Cartesian Trace Formats

Cartesian trace formats assign a scalar response to the stimulus value (frequency, power, or time). The response can be calculated from the measured quantity at the related stimulus value, but it can also be the result of some mathematical transformation of the original (unformatted) trace.

Diagram Representation

When a Cartesian trace is assigned to a diagram, the stimulus variable appears on the horizontal axis (x-axis), the response values appear on the vertical axis (y-axis).

Graph Scaling

- Except for the "Log Mag" format, the y-axis scale is always linear.
- The x-axis scaling depends on the sweep type of the channel to which the trace is assigned:
 - For sweep types "Lin Freq", "Power", "CW Mode" and "Time" it is scaled linearly.
 - For sweep type "Log Freq", it is scaled logarithmically.

The resulting linear or lin-log grid is plotted with the formatted trace.

The following examples show "dB Mag" Cartesian traces for the same measured quantity and sweep range, but with "Lin Freq" and "Log Freq" sweep types.

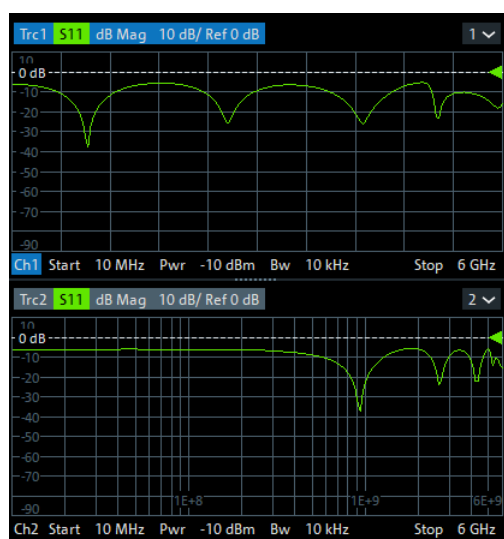

Figure 5-5: S11 trace in dB Mag format: sweep type Lin Freq (top) and Log Freq (bottom)

Conversion of Complex to Real Quantities

Among the measured quantities the R&S ZND supports, only "Stability" factors and "Power Sensor" results are real. All other measured quantities are complex.

The following table shows how "real" response values are calculated from complex measurement values $z = x + j y$ (where x , y , z are functions of the sweep variable). The formulas also hold for real measurement values ($y = 0$).

Trace Format	Description	Formula
"dB Mag"	Magnitude of z in dB	$\text{dB Mag}(z) = 20 * \log z \text{ dB}$
"Phase"	Phase of z	$\varphi(z) = \arctan(y/x)$
"SWR"	(Voltage) Standing Wave Ratio	$\text{SWR} = (1 + z) / (1 - z)$
"Lin Mag"	Magnitude of z , unconverted	$ z = \text{sqrt}(x^2 + y^2)$
"Real"	Real part of z	$\text{Re}(z) = x$

Trace Format	Description	Formula
"Imag"	Imaginary part of z	$\text{Im}(z) = y$
"Delay"	Group delay, neg. derivative of the phase response	$-\text{d} \varphi (z) / \text{d} \Omega \quad (\Omega = 2\pi * f)$



An extended range of formats and conversion formulas is available for markers. To convert any point on a trace, create a marker and select the appropriate marker format. Marker and trace formats can be selected independently.

5.2.3.2 Complex Trace Formats

Complex trace formats assign a complex response to the stimulus value (frequency, power, or time).

In diagrams, the response values are always represented as points in the two-dimensional complex plane:

- The complex 0 is located at the center of the diagram.
- The real part is drawn in horizontal direction, the imaginary part in vertical direction.

Result values for consecutive stimulus values are interconnected by straight lines, so the trace is represented as a polygonal chain in the complex plane.

The stimulus axis is not visible. However, the stimulus value for a given trace point can be displayed using a marker.

The difference between the different complex trace formats ([Polar](#), [Smith](#) and [Inv Smith](#)) is the coordinate system that is used for the representation of the response values and that is graphically overlaid to the formatted trace.

Polar

For "Polar" traces the complex response values are represented in polar coordinates: magnitude and phase.

In a diagram the grid lines overlaid to the trace correspond to points of equal magnitude and phase:

- Points with equal magnitude are located on circles around the complex 0 that is located at the center of the diagram.
- Points with the equal phase are located on straight lines originating at the center.

The following example shows a polar diagram with a marker used to display a pair of stimulus and response values.

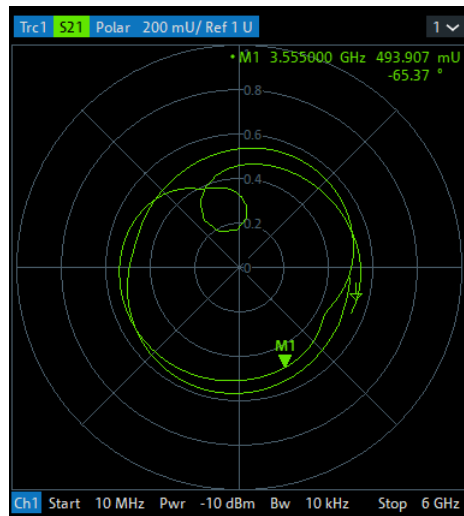

Example: Reflection coefficients in polar diagrams

If the measured quantity is a complex reflection coefficient (S_{11} , S_{22} etc.), then the center of the polar diagram corresponds to a perfect load Z_0 at the input test port of the DUT (no reflection, matched input). The outer circumference ($|S_{ij}| = 1$) represents a totally reflected signal.

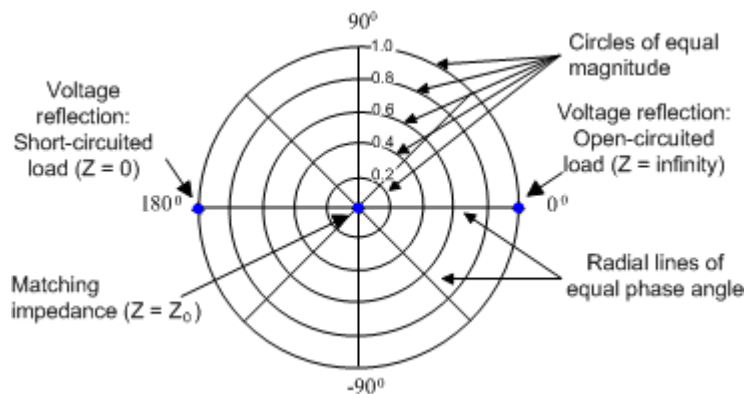

Examples for definite magnitudes and phase angles:

- The magnitude of the reflection coefficient of an open circuit ($Z = \text{infinity}$, $I = 0$) is one, its phase is zero.
- The magnitude of the reflection coefficient of a short circuit ($Z = 0$, $U = 0$) is one, its phase is -180 deg.

Smith

For "Smith" traces the response values are interpreted as reflection coefficients S_{ij} and represented in terms of their corresponding complex impedance $Z(S_{ij}) = R(S_{ij}) + j X(S_{ij})$.

In a diagram, the grid lines overlaid to a "Smith" trace correspond to points of equal resistance R and reactance X :

- Points with the same resistance are located on circles.

- Points with the same reactance produce arcs.

The following example shows a Smith chart with a marker used to display the stimulus value, the complex impedance $Z = R + j X$ and the equivalent inductance L .

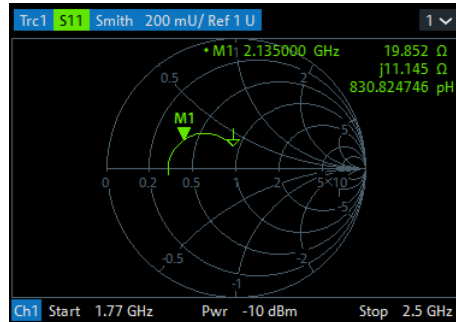

Smith chart construction

In a Smith chart, the impedance plane is reshaped so that the area with positive resistance is mapped into a unit circle.

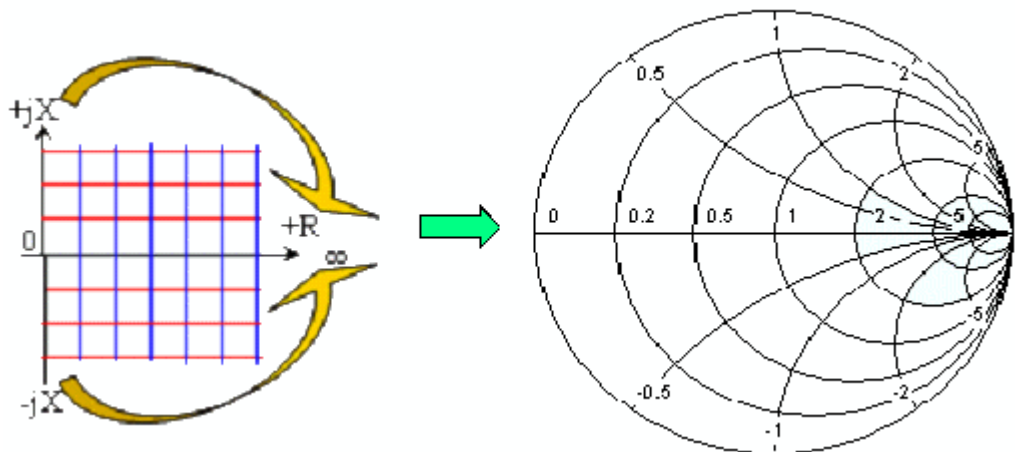

The basic properties of the Smith chart follow from this construction:

- The central horizontal axis corresponds to zero reactance (real impedance). The center of the diagram represents $Z/Z_0 = 1$ which is the reference impedance of the system (zero reflection). At the left and right intersection points between the horizontal axis and the outer circle, the impedance is zero (short) and infinity (open).
- The outer circle corresponds to zero resistance (purely imaginary impedance). Points outside the outer circle indicate an active component.
- The upper and lower half of the diagram correspond to positive (inductive) and negative (capacitive) reactive components of the impedance, respectively.

Example: Reflection coefficients in the Smith chart

If the measured quantity is a complex reflection coefficient Γ (e.g. S_{11} , S_{22}), then the unit Smith chart can be used to read the normalized impedance of the DUT. The coor-

ordinates in the normalized impedance plane and in the reflection coefficient plane are related as follows (see also: definition of matched-circuit (converted) impedances):

$$Z/Z_0 = \frac{1 + \Gamma}{1 - \Gamma}$$

From this equation, it is easy to relate the real and imaginary components of the complex resistance to the real and imaginary parts of Γ :

$$R = \text{Re}(Z/Z_0) = \frac{1 - \text{Re}(\Gamma)^2 - \text{Im}(\Gamma)^2}{[1 - \text{Re}(\Gamma)]^2 + \text{Im}(\Gamma)^2}$$

$$X = \text{Im}(Z/Z_0) = \frac{2 \text{Im}(\Gamma)}{[1 - \text{Re}(\Gamma)]^2 + \text{Im}(\Gamma)^2}$$

According to the two equations above, the graphical representation in a Smith chart has the following properties:

- Real reflection coefficients are mapped to real impedances (resistances).
- The center of the Γ plane ($\Gamma = 0$) is mapped to the reference impedance Z_0 , whereas the circle with $|\Gamma| = 1$ is mapped to the imaginary axis of the Z plane.
- The circles for the points of equal resistance are centered on the real axis and intersect at $Z = \text{infinity}$. The arcs for the points of equal reactance also belong to circles intersecting at $Z = \text{infinity}$ (open circuit point $(1, 0)$), centered on a straight vertical line.

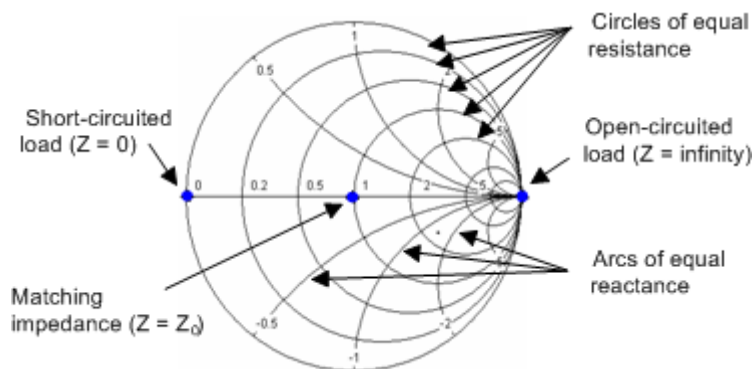

Examples for special points in the Smith chart:

- The magnitude of the reflection coefficient of an open circuit ($Z = \text{infinity}$, $\Gamma = 1$) is one, its phase is zero.
- The magnitude of the reflection coefficient of a short circuit ($Z = 0$, $\Gamma = -1$) is one, its phase is -180 deg.

Inv Smith

For "Inv Smith" formatted traces, the response values are interpreted as complex reflection coefficients S_{ij} and represented in terms of their corresponding complex admittance $Y(S_{ij}) = G(S_{ij}) + j B(S_{ij})$.

In a diagram, the grid lines overlaid to a "Smith" trace correspond to points of equal conductance G and susceptance B :

- Points with the same conductance are located on circles.
- Points with the same susceptance produce arcs.

The following example shows an inverted Smith chart with a marker used to display the stimulus value, the complex admittance $Y = G + jB$ and the equivalent inductance L .

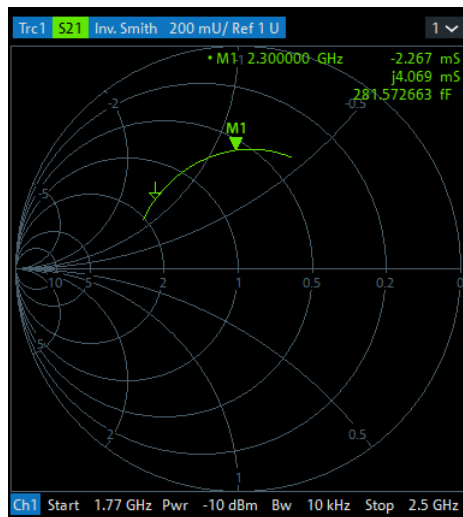

Inverted Smith chart construction

The inverted Smith chart is point-symmetric to the Smith chart:

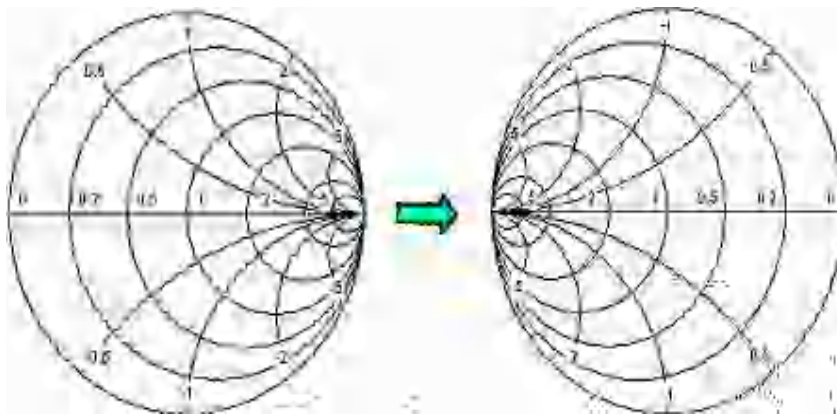

The basic properties of the inverted Smith chart follow from this construction:

- The central horizontal axis corresponds to zero susceptance (real admittance). The center of the diagram represents $Y/Y_0 = 1$, where Y_0 is the reference admittance of the system (zero reflection). At the left and right intersection points between the horizontal axis and the outer circle, the admittance is infinity (short) and zero (open).
- The outer circle corresponds to zero conductance (purely imaginary admittance). Points outside the outer circle indicate an active component.

- The upper and lower half of the diagram correspond to negative (inductive) and positive (capacitive) susceptive components of the admittance, respectively.

Example: Reflection coefficients in the inverted Smith chart

If the measured quantity is a complex reflection coefficient Γ (e.g. S_{11} , S_{22}), then the inverted Smith chart can be used to read the normalized admittance of the DUT. The coordinates in the normalized admittance plane and in the reflection coefficient plane are related as follows (see also: definition of matched-circuit (converted) admittances):

$$Y/Y_0 = \frac{1 - \Gamma}{1 + \Gamma}$$

From this equation, it is easy to relate the real and imaginary components of the complex admittance to the real and imaginary parts of Γ :

$$G = \text{Re}(Y/Y_0) = \frac{1 - \text{Re}(\Gamma)^2 - \text{Im}(\Gamma)^2}{[1 + \text{Re}(\Gamma)]^2 + \text{Im}(\Gamma)^2}$$

$$B = \text{Im}(Y/Y_0) = \frac{-2 \text{Im}(\Gamma)}{[1 + \text{Re}(\Gamma)]^2 + \text{Im}(\Gamma)^2}$$

According to the two equations above, the graphical representation in an inverted Smith chart has the following properties:

- Real reflection coefficients are mapped to real admittances (conductances).
- The center of the Γ plane ($\Gamma = 0$) is mapped to the reference admittance Y_0 , whereas the circle with $|\Gamma| = 1$ is mapped to the imaginary axis of the Y plane.
- The circles for the points of equal conductance are centered on the real axis and intersect at $Y = \text{infinity}$. The arcs for the points of equal susceptance also belong to circles intersecting at $Y = \text{infinity}$ (short circuit point $(-1, 0)$), centered on a straight vertical line.

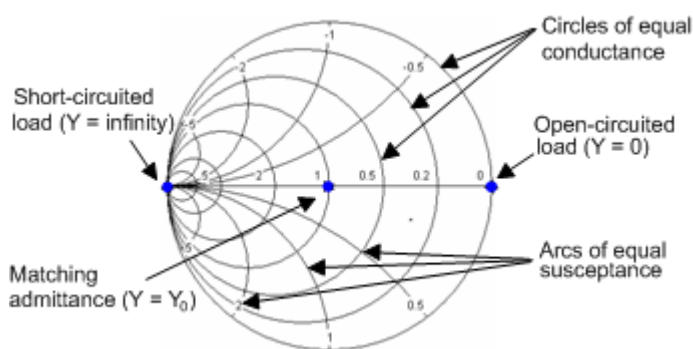

Examples for special points in the inverted Smith chart:

- The magnitude of the reflection coefficient of a short circuit ($Y = \text{infinity}$, $U = 0$) is one, its phase is -180 deg.
- The magnitude of the reflection coefficient of an open circuit ($Y = 0$, $I = 0$) is one, its phase is zero.

5.2.3.3 Measured Quantities and Trace Formats

The analyzer allows any combination of a display format and a measured quantity. The following rules can help to avoid inappropriate formats and find the format that is ideally suited to the measurement task.

- All formats are suitable for the analysis of reflection coefficients S_{ij} . The formats "SWR", "Smith" and "Inv Smith" lose their original meaning (standing wave ratio, normalized impedance or admittance) if they are used for transmission S-parameters, ratios and other quantities.
- For complex "Impedances", "Admittances", "Z-parameters", and "Y-parameters" generally a Cartesian format or the polar format is suitable.
- For the real valued [Stability Factors](#), one of the Cartesian formats "Lin Mag" or "Real" should be used. In complex formats, real numbers represent complex numbers with zero imaginary part.

The following table gives an overview of recommended display formats.

	Complex dimensionless quantities: S-parameters and ratios	Complex quantities with dimensions: Wave quantities, Z-parameters, Y-parameters, impedances, admittances	Real quantities: Stability Factors
Lin Mag	ON	ON (default for Z-parameters, Y-parameters, impedances, admittances)	ON (default)
dB Mag	ON (default)	ON (default for wave quantities)	–
Phase	ON	ON	–
Real	ON	ON	ON
Imag	ON	ON	–
Unwrapped Phase	ON	ON	–
Smith	ON (reflection coefficients S_{ij})	–	–
Polar	ON	–	–
Inverted Smith	ON (reflection coefficients S_{ij})	–	–
SWR	ON (reflection coefficients S_{ij})	–	–
Delay	ON (transmission coefficients S_{ij})	–	–

The default formats are activated automatically when the measured quantity is changed.

5.3 Measurement Results

This section gives an overview of the measurement results of the network analyzer and the meaning of the different measured quantities. All quantities can be selected in the "Meas" softtool (function key TRACE – [MEAS]).

5.3.1 S-Parameters

S-parameters are the basic measured quantities of a network analyzer. They describe how the DUT modifies a signal that is transmitted or reflected in forward or reverse direction. For a 2-port measurement, the signal flow is as follows.

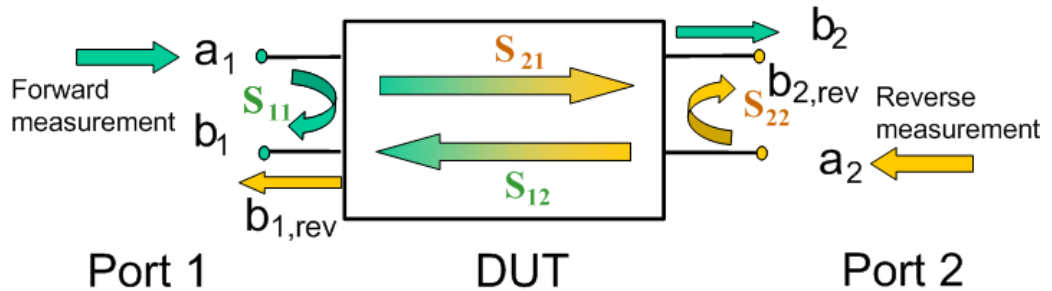

The figure above is sufficient for the definition of S-parameters but does not necessarily show the complete signal flow. In fact, if the source and load ports are not ideally matched, part of the transmitted waves are reflected off the receiver ports. An additional a_2 contribution occurs in forward measurements, and an a_1 contribution occurs in reverse measurements. The 7-term calibration types Txx take these additional contributions into account.

The scattering matrix links the incident waves a_1, a_2 to the outgoing waves b_1, b_2 according to the following linear equation:

$$\begin{bmatrix} b_1 \\ b_2 \end{bmatrix} = \begin{bmatrix} S_{11} & S_{12} \\ S_{21} & S_{22} \end{bmatrix} \begin{bmatrix} a_1 \\ a_2 \end{bmatrix}$$

Meaning of 2-port S-parameters

The four 2-port S-parameters can be interpreted as follows:

- S_{11} is the reflection coefficient of DUT port 1, i.e. the ratio between outgoing wave b_1 and incident wave a_1 in a forward measurement with matched DUT port 2:
 $S_{11} = b_1 / a_1$, if $|a_1| > 0$ and $a_2 = 0$
- S_{21} is the forward transmission coefficient, defined as the ratio between outgoing wave b_2 and incident wave a_1 in a forward measurement with matched DUT port 2:
 $S_{21} = b_2 / a_1$, if $|a_1| > 0$ and $a_2 = 0$
- S_{12} is the reverse transmission coefficient, defined as the ratio between outgoing wave b_1 and incident wave a_2 in a forward measurement with matched DUT port 1:
 $S_{12} = b_1 / a_2$, if $|a_2| > 0$ and $a_1 = 0$
- S_{22} is the reflection coefficient of port 2, i.e. the ratio between outgoing wave b_2 and incident wave a_2 in a forward measurement with matched DUT port 1:
 $S_{22} = b_2 / a_2$, if $|a_2| > 0$ and $a_1 = 0$



With a unidirectional R&S ZND (see [Chapter 5.1.4.3, "R&S ZND: Unidirectional vs. Bidirectional Operation"](#), on page 75) "reverse direction" S-parameters S_{i2} ($i=1,2$) cannot be measured.

Meaning of squared amplitudes

The squared amplitudes of the incident and outgoing waves and of the matrix elements have a simple meaning:

Table 5-3: Squared S-parameters

$ a_i ^2$	Available incident power (= the power provided by a generator with a source impedance equal to the reference impedance Z_0) at DUT port $i=1,2$
$ b_i ^2$	Reflected power at DUT port $i=1,2$
$10 \log S_{ii} ^2 = 20 \log S_{ii} $	Reflection loss at DUT port $i=1,2$
$10 \log S_{21} ^2 = 20 \log S_{21} $	Insertion loss of forward transmission
$10 \log S_{12} ^2 = 20 \log S_{12} $	Insertion loss of reverse transmission

5.3.1.1 Multiport S-Parameters

The multiport S-parameters extend the standard 2-port S-parameters to a larger number of incident and outgoing waves. For a 4-port DUT,

$$\begin{bmatrix} b_1 \\ b_2 \\ b_3 \\ b_4 \end{bmatrix} = \begin{bmatrix} S_{11} & S_{12} & S_{13} & S_{14} \\ S_{21} & S_{22} & S_{23} & S_{24} \\ S_{31} & S_{32} & S_{33} & S_{34} \\ S_{41} & S_{42} & S_{43} & S_{44} \end{bmatrix} * \begin{bmatrix} a_1 \\ a_2 \\ a_3 \\ a_4 \end{bmatrix}$$

where again a_i ($i = 1$ to 4) denote the incident, b_i ($i = 1$ to 4) denote the outgoing waves, and the S-parameters are expressed as S_{ij} ($i, j = 1$ to 4).

The indices of the S-parameters described so far number the output and input ports of a DUT; the parameters are referred to as single-ended S-parameters. The S-parameter description can also be used to differentiate between different propagation modes of the waves at the output and input ports. This results in the so-called mixed mode S-parameters. The analyzer measures either single-ended or mixed mode S-parameters.

5.3.2 Reference Impedances

Changing the reference impedances of the analyzer ports is often referred to as renormalization of port impedances. Renormalization means that the measurement results measured at 50 Ω (75 Ω) are converted into results at arbitrary port impedance.

- Renormalization of the physical port impedances affects, e.g., S-parameters and wave quantities in "Power" representation.
- Renormalization of the balanced port impedances affects all measured quantities that the analyzer provides for balanced ports.

The default reference impedance of a physical port is equal to the reference impedance of the connector type assigned to the port (50 Ω or 75 Ω). It can be defined as a complex value. For balanced ports, it is possible to define separate complex reference impedances for differential and for common mode.

The default values for the balanced port reference impedances are derived from the default reference impedance of the physical analyzer ports ($Z_0 = 50 \Omega$):

- The default value for the differential mode is $Z_{0d} = 100 \Omega = 2 \cdot Z_0$.
- The default value for the common mode is $Z_{0c} = 25 \Omega = Z_0/2$.

Renormalization can be based on two alternative waveguide circuit theories whose conversion formulas may yield different results if the reference impedance of at least one test port has a non-zero imaginary part.

Conversion formula for wave quantities and S-parameters

Renormalization transforms the "raw" S-matrix S_0 for the default reference impedances Z_{0i} (with physical port number index $i = 1, 2, \dots, n$) into a "renormalized" S-matrix S_1 for the modified reference impedances Z_{1i} . In terms of raw and renormalized wave quantities a_{0i} , b_{0i} and a_{1i} , b_{1i} , S_0 and S_1 are defined as follows:

$$\begin{pmatrix} b_{01} \\ b_{02} \\ \dots \\ b_{0n} \end{pmatrix} = S_0 \cdot \begin{pmatrix} a_{01} \\ a_{02} \\ \dots \\ a_{0n} \end{pmatrix}; \quad \begin{pmatrix} b_{11} \\ b_{12} \\ \dots \\ b_{1n} \end{pmatrix} = S_1 \cdot \begin{pmatrix} a_{11} \\ a_{12} \\ \dots \\ a_{1n} \end{pmatrix}.$$

The renormalized wave quantities (a_1 and b_1) and the S-matrix S_1 can be calculated from S_0 and the reference impedances Z_{0i} , Z_{1i} according to two alternative waveguide circuit theories.

1. Traveling waves

In the model of Marks and Williams ("A General Waveguide Circuit Theory"), the wave quantities a and b are transformed as follows:

$$\begin{pmatrix} a_{1i} \\ b_{1i} \end{pmatrix} = \frac{1}{2Z_{0i}} \left| \frac{Z_{0i}}{Z_{1i}} \right| \sqrt{\frac{\operatorname{Re}(Z_{1i})}{\operatorname{Re}(Z_{0i})}} \cdot \begin{pmatrix} Z_{0i} + Z_{1i} & Z_{0i} - Z_{1i} \\ Z_{0i} - Z_{1i} & Z_{0i} + Z_{1i} \end{pmatrix} \cdot \begin{pmatrix} a_{0i} \\ b_{0i} \end{pmatrix}$$

The renormalized S-matrix S_1 is calculated as:

$$S_1 = P^{-1} (S_0 - \gamma) (E - \gamma S_0)^{-1} P$$

with the unit matrix E and two additional matrices with the elements

$$\gamma_{ii} = \frac{Z_{1i} - Z_{0i}}{Z_{1i} + Z_{0i}}$$

$$P_{ii} = \frac{Z_{0i}}{Z_{0i} + Z_{1i}} \left| \frac{Z_{1i}}{Z_{0i}} \right| \sqrt{\frac{\operatorname{Re}(Z_{0i})}{\operatorname{Re}(Z_{1i})}}$$

2. Power waves

In the model of Kurokawa ("Power Waves and the Scattering Matrix"), the wave quantities a and b are transformed as follows:

$$\begin{pmatrix} a_{1i} \\ b_{1i} \end{pmatrix} = \frac{1}{2\sqrt{\operatorname{Re}(Z_{0i})\operatorname{Re}(Z_{1i})}} \cdot \begin{pmatrix} \overline{Z_{0i}} + Z_{1i} & Z_{0i} - \overline{Z_{1i}} \\ \overline{Z_{0i}} - \overline{Z_{1i}} & Z_{0i} + \overline{Z_{1i}} \end{pmatrix} \cdot \begin{pmatrix} a_{0i} \\ b_{0i} \end{pmatrix}$$

The renormalized S-matrix S1 is calculated as:

$$S_1 = A^{-1}(S_0 - \overline{\Gamma})(E - \Gamma S_0)^{-1} \overline{A}$$

with the unit matrix E and two additional matrices with the elements

$$\Gamma_{ii} = \frac{Z_{1i} - Z_{0i}}{Z_{1i} + \overline{Z_{0i}}}$$

$$A_{ii} = \frac{1 - \overline{\Gamma_{ii}}}{|1 - \Gamma_{ii}|} \sqrt{|1 - \Gamma_{ii} \overline{\Gamma_{ii}}|}$$

5.3.3 Impedance Parameters

An impedance is the complex ratio between a voltage and a current. The analyzer provides two independent sets of impedance parameters:

- Converted impedances (each impedance parameter is obtained from a single S-parameter)
- Z-parameters (complete description of an n-port DUT)

5.3.3.1 Converted Impedances

The converted impedance parameters Z_{ij} ($1 \leq i, j \leq n$) describe the input impedances of an n-port DUT with fully matched outputs. The analyzer converts a single measured S-parameter S_{ij} to determine the corresponding converted impedance, under the assumption that each of the other ports is terminated with its respective reference impedance Z_{0k} (matched-circuit parameters). As a result, converted impedances cannot completely describe general n-port DUTs.



With a unidirectional R&S ZND (see [Chapter 5.1.4.3, "R&S ZND: Unidirectional vs. Bidirectional Operation"](#), on page 75) "reverse direction" converted impedances Z_{i2} cannot be measured.

The [Converted Admittances](#) are defined as the inverse of the converted impedances.

Reflection Impedance

The converted impedance Z_{ii} ($1 \leq i \leq n$) describes the input impedance at port i of the DUT.

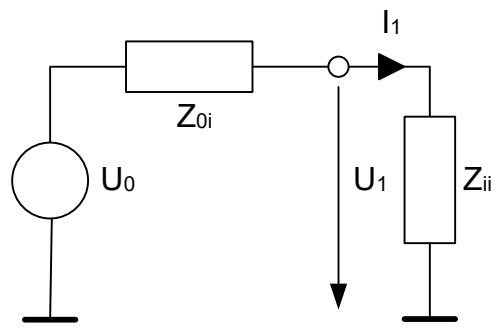
**Example:**

For a 2-port DUT that is terminated at its output with the reference impedance Z_{02} , Z_{11} is the input impedance (matched-circuit impedance measured in a forward reflection measurement).

A converted impedance Z_{11} completely describes a one-port DUT.

The calculation formula of the converted reflection impedances Z_{ii} depends on the waveguide circuit theory according to which [Reference Impedances](#) are calculated.

Table 5-4: Calculation of Converted Reflection Impedances

Traveling Waves	Power Waves
$Z_{ii} = Z_{0i} \frac{1 + S_{ii}}{1 - S_{ii}}$	$Z_{ii} = \frac{\overline{Z_{0i}} + S_{ii} Z_{0i}}{1 - S_{ii}}$

Series Transmission Impedance

A two-port transmission parameter Z_{ij} ($i \neq j$) can describe a pure serial impedance between the two ports.

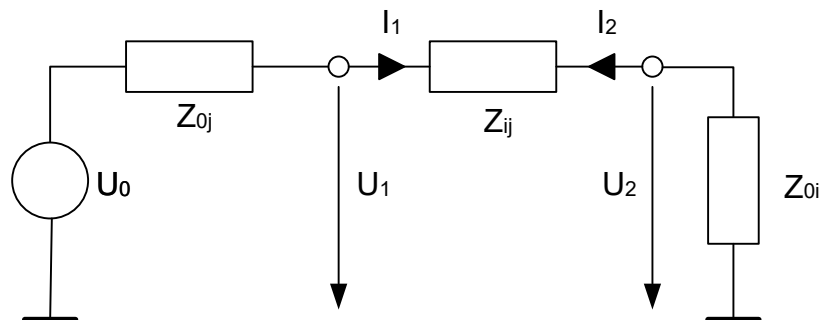

The calculation formula of a converted serial transmission impedance Z_{ij} depends on the waveguide circuit theory according to which [Reference Impedances](#) are calculated.

Table 5-5: Calculation of Converted Series Transmission Impedances

Traveling Waves	Power Waves
$Z = 2e^{j\varphi(Z_{0i})} \sqrt{\left \frac{\text{Re}(Z_{0i})}{\text{Re}(Z_{0j})} \right } \frac{ Z_{0j} }{S_{ij}} - (Z_{0i} + Z_{0j})$	$Z = 2 \text{sgn}(\text{Re}(Z_{0i})) \frac{\sqrt{ \text{Re}(Z_{0i})\text{Re}(Z_{0j}) }}{S_{ij}} - (Z_{0i} + Z_{0j})$

Parallel Transmission Impedance

A two-port transmission parameter Z_{ij} ($i \neq j$) can also describe a parallel impedance between the two ports.

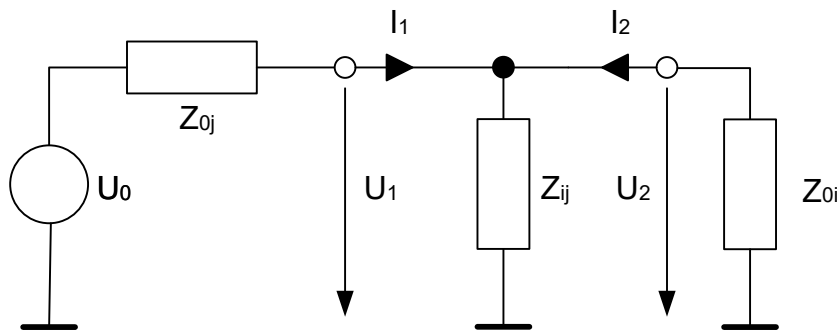

The calculation formula of a converted parallel transmission impedance Z_{ij} depends on the waveguide circuit theory according to which [Reference Impedances](#) are calculated.

Table 5-6: Calculation of Converted Parallel Transmission Impedances

Traveling Waves	Power Waves
$Z = \frac{Z_{0i} Z_{0j} S_{ij}}{2 \left(Z_{0i} \left \frac{Z_{0j}}{Z_{0i}} \right \sqrt{\left \frac{\text{Re}(Z_{0i})}{\text{Re}(Z_{0j})} \right } - S_{ij} \frac{Z_{0i} + Z_{0j}}{2} \right)}$	$Z = \frac{Z_{0j} S_{ij}}{\sqrt{\left \frac{\text{Re}(Z_{0j})}{\text{Re}(Z_{0i})} \right } (1 + e^{-2\varphi(Z_{0i})}) - S_{ij} \left(1 + \frac{Z_{0j}}{Z_{0i}} \right)}$

Shunt-thru Measurements

The shunt-thru method is used for measuring very low impedances. A typical application are measurements on power distribution network (PDN) components, such as bypass capacitors and DC-DC converters.

The R&S ZND uses S_{ij} ($i \neq j$) to calculate the DUT impedance using the formula:

$$Z = \frac{50 \Omega}{2} \cdot \frac{S_{ij}}{1 - S_{ij}}$$

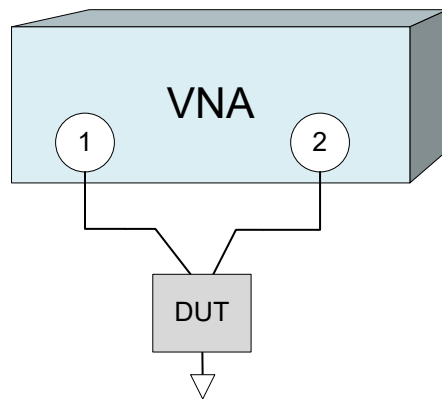

5.3.3.2 Z-Parameters

The Z-parameters describe the impedances of a DUT with open output ports (impedance = 0). The analyzer provides the full set of Z-parameters including the transfer impedances (i.e. the complete $n \times n$ Z-matrix for an n port DUT).

This means that Z-parameters can be used as an alternative to S-parameters (or Y-parameters) to characterize a linear n -port network completely.

2-Port Z-Parameters

In analogy to S-parameters, Z-parameters are expressed as Z_{ij} , where i denotes the measured and j the stimulated port.

The Z-parameters for a two-port are based on a circuit model that can be expressed with two linear equations:

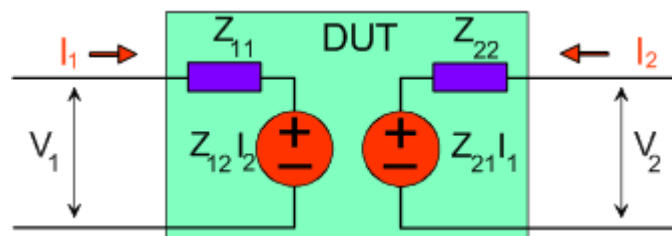

$$V_1 = Z_{11}I_1 + Z_{12}I_2$$

$$V_2 = Z_{21}I_1 + Z_{22}I_2$$

Meaning of Z-parameters

The four 2-port Z-parameters can be interpreted as follows:

- Z_{11} is the input impedance, defined as the ratio of the voltage V_1 to the current I_1 , measured at port 1 (forward measurement with open output, $I_2 = 0$).
- Z_{21} is the forward transfer impedance, defined as the ratio of the voltage V_2 to the current I_1 (forward measurement with open output, $I_2 = 0$).
- Z_{12} is the reverse transfer impedance, defined as the ratio of the voltage V_1 to the current I_2 (reverse measurement with open input, $I_1 = 0$).

- Z_{22} is the output impedance, defined as the ratio of the voltage V_2 to the current I_2 , measured at port 2 (reverse measurement with open input, $I_1 = 0$).

Z-parameters can be easily extended to describe circuits with more than two ports or several modes of propagation.



With a unidirectional R&S ZND (see [Chapter 5.1.4.3, "R&S ZND: Unidirectional vs. Bidirectional Operation"](#), on page 75) Z-Parameters cannot be measured.

5.3.4 Admittance Parameters

An admittance is the complex ratio between a current and a voltage. The analyzer provides two independent sets of admittance parameters:

- Converted admittances (each admittance parameter is obtained from a single S-parameter)
- Y-parameters (complete description of the n-port DUT)

5.3.4.1 Converted Admittances

The converted admittance parameters describe the input admittances of a DUT with fully matched outputs. The converted admittances are the inverse of the [Converted Impedances](#).

5.3.4.2 Y-Parameters

The Y-parameters describe the admittances of a DUT with output ports terminated in a short circuit (voltage = 0). The analyzer provides the full set of Y-parameters including the transfer admittances (i.e. the complete $n \times n$ Y-matrix for an n port DUT).

This means that Y-parameters can be used as an alternative to S-parameters (or Z-parameters) to characterize a linear n -port network completely.

2-Port Y-Parameters

In analogy to S-parameters, Y-parameters are expressed as $Y_{\langle out \rangle \langle in \rangle}$, where $\langle out \rangle$ and $\langle in \rangle$ denote the output and input port numbers of the DUT. In analogy to Z-parameters, the Y-parameters for a two-port are based on a circuit model that can be expressed with two linear equations:

$$I_1 = Y_{11}V_1 + Y_{12}V_2$$

$$I_2 = Y_{21}V_1 + Y_{22}V_2$$

Meaning of Y-parameters

The four 2-port Y-parameters can be interpreted as follows:

- Y_{11} is the input admittance, defined as the ratio of the current I_1 to the voltage V_1 , measured at port 1 (forward measurement with output terminated in a short circuit, $V_2 = 0$).

- Y_{21} is the forward transfer admittance, defined as the ratio of the current I_2 to the voltage V_1 (forward measurement with output terminated in a short circuit, $V_2 = 0$).
- Y_{12} is the reverse transfer admittance, defined as the ratio of the current I_1 to the voltage V_2 (reverse measurement with input terminated in a short circuit, $V_1 = 0$).
- Y_{22} is the output admittance, defined as the ratio of the current I_2 to the voltage V_2 , measured at port 2 (reverse measurement with input terminated in a short circuit, $V_1 = 0$).

Y-parameters can be easily extended to describe circuits with more than two ports or several modes of propagation.



With a unidirectional R&S ZND (see [Chapter 5.1.4.3, "R&S ZND: Unidirectional vs. Bidirectional Operation"](#), on page 75) Y-Parameters cannot be measured.

5.3.5 Wave Quantities and Ratios

The elements of the S-, Z- and Y-matrices represent fixed ratios of complex wave amplitudes. As long as the assumption of linearity holds, the S-, Z- and Y-parameters are independent of the source power.

The network analyzer provides two additional sets of measurement parameters which have an unambiguous meaning even if the DUT is measured outside its linear range:

- *Wave quantities* provide the power of any of the transmitted or received waves.
- *Ratios* provide the complex ratio of any combination of transmitted or received wave quantities.



In contrast to S-, Z- and Y-parameters, wave quantities and ratios are not system-error corrected.

To increase the accuracy or to correct a possible attenuation in the source signal path, it is recommended to perform a power calibration (see [Chapter 5.5.6, "Scalar Power Calibration"](#), on page 167).

5.3.5.1 Wave Quantities

A wave quantity measurement provides the power of any of the transmitted or received waves. The power can be displayed in voltage units (e.g. V or dBmV) or equivalent power units (e.g. W or dBm).



Examples for using wave quantities

The wave quantities provide the power at the different receive ports of the analyzer. This is different from an S-parameter measurement, where the absolute power of a linear device is canceled. Wave quantities are therefore suitable for the following measurement tasks:

- Analysis of nonlinearities of the DUT.
- Use of the analyzer as a selective power meter.
To increase the accuracy or to correct a possible attenuation in the source signal path, it is recommended to perform a power calibration (see [Chapter 5.5.6, "Scalar Power Calibration"](#), on page 167).

The notation for wave quantities is as follows:

- " a_i Src Port j " denotes the wave incoming at DUT port i , when DUT port j is stimulated.
 a_i is detected at the reference receiver of the VNA port connected to DUT port i .
- " b_i Src Port j " denotes the wave outgoing at DUT port i , when DUT port j is stimulated.
 b_i is detected at the measurement receiver of the VNA port connected to DUT port i .

In a standard forward S-parameter measurement, a_1 Src Port 1 is the incident wave and b_1 Src Port 1 is the reflected wave at DUT port 1.



With a unidirectional R&S ZND (see [Chapter 5.1.4.3, "R&S ZND: Unidirectional vs. Bidirectional Operation"](#), on page 75) the reverse direction wave quantities a_2 and b_1 cannot be measured.

5.3.5.2 Ratios

A ratio measurement provides the complex ratio of any combination of transmitted or received wave amplitudes. Ratios complement the S-parameter measurements, where only ratios of the form b_i/a_j (ratios between outgoing and incoming waves at the DUT ports) are considered.



With a unidirectional R&S ZND (see [Chapter 5.1.4.3, "R&S ZND: Unidirectional vs. Bidirectional Operation"](#), on page 75) ratios involving the reverse wave quantities a_2 and b_1 cannot be measured.



Examples for using ratios

A measurement of ratios is particularly suitable for the following test scenarios:

- The test setup or some of its components (e.g. active components or non-reciprocal devices) do not allow a system error correction so that a complete S-parameter measurement is not possible.
- The test setup contains frequency-converting components so that the transmitted and the received waves are at different frequencies.
- A ratio of two arbitrary waves that is not an element of the S-matrix (e.g. a ratio of the form a_i/a_j) is needed.

The notation for ratios is similar to the notation for wave quantities (see [Chapter 5.3.5.1, "Wave Quantities"](#), on page 112). Given a source port k , any ratio between wave quantities " a_i Src Port k " and " b_j Src Port k " can be measured.

Examples:

- " b_2/a_1 Src Port 1" is the ratio of the outgoing wave at DUT port 2 and the incident wave at DUT port 1 (i.e. DUT port 1 ist stimulated). This corresponds to the forward transmission coefficient S_{21} .
- " b_1/a_1 Src Port 1" is the ratio of the outgoing wave at DUT port 1 and the incident wave at DUT port 1 (i.e. DUT port 1 ist stimulated). This corresponds to the forward reflection coefficient S_{11} .

5.3.5.3 Detector Settings

The "Detector" settings select the algorithm that is used to calculate the displayed measurement points from the raw data. The "Detector" can be selected in the "More Wave Quantities" and More Ratios dialogs.

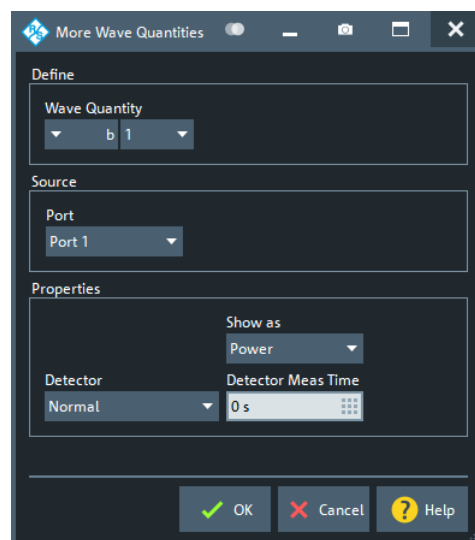

Figure 5-6: More Wave Quantities dialog

The following detectors are available:

- **"Normal"** selects the default detector mode where each valid measurement point is displayed without modification. The analyzer then proceeds to the next sweep point. Normal detector mode ensures that the measurement is performed at maximum speed and that a meaningful complex result is obtained.
- **"AVG Real Imag"** collects all valid results at each sweep point during the "Detector Meas Time" set in the "More Wave Quantities" or More Ratios dialog and calculates the complex arithmetic mean of their real and imaginary parts.
- **AVG Mag Phase** collects all valid results at each sweep point during the "Detector Meas Time" set in the "More Wave Quantities" or More Ratios dialog. It calculates the arithmetic mean of the magnitude and phase values of these results separately.



Combining different detectors

The detector setting in the More Ratios menu applies to both the numerator and the denominator wave quantity. To allow for different detector settings, measure the numerator and denominator wave quantities individually and use trace functions to calculate the ratio. A possible application is the comparison of different detector settings for a particular trace.



Error Messages

The analyzer generates a warning if the selected measurement time for the "AVG..." detectors is too long. At the same time, bit no. 15 in the `...INTEGRITY:HARDWARE` status register is set. Reduce the measurement time and/or reduce the IF bandwidth until the warning disappears. A warning also appears if the measurement time for the "AVG..." detectors is too short. Increase the measurement time and/or increase the IF bandwidth until the warning disappears.

5.3.6 Unbalance-Balance Conversion

Unbalance-balance conversion is the simulation of one or more unbalance-balance transformers (baluns) integrated in the measurement circuit. It converts the DUT ports from an unbalanced state into a balanced state and virtually separates the differential and common mode signals. The analyzer measures the unbalanced state but converts the results and calculates mixed mode parameters, e.g. mixed mode S-parameters. No physical transformer is needed.

To perform balanced measurements, a pair of physical analyzer ports is combined to form a logical port. The balanced port of the DUT is directly connected to the analyzer ports. For a two-port analyzer, a single balanced port can be defined.

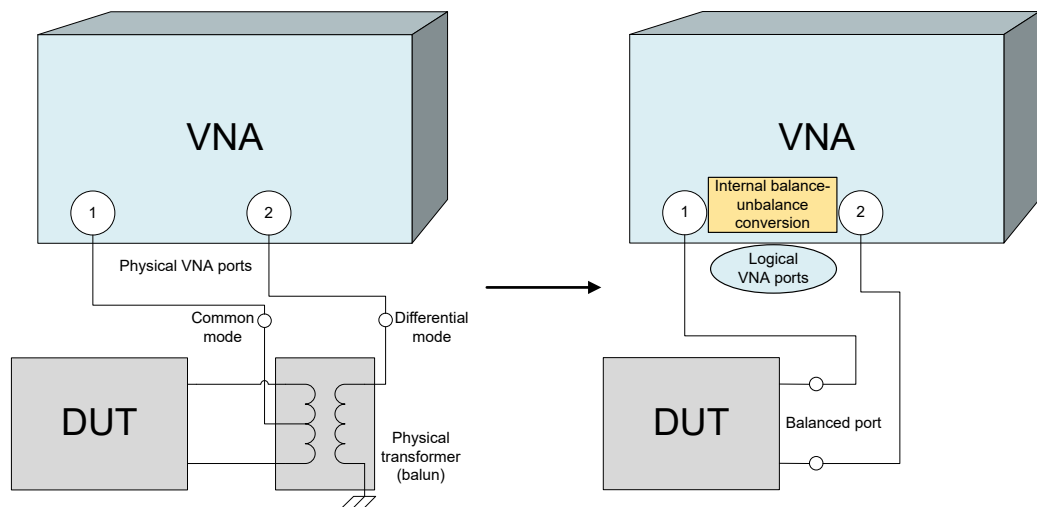

Unbalance-balance conversion avoids the disadvantages of real transformers:

- There is no need to fabricate test fixtures with integrated baluns for each type of DUT.
- The measurement is not impaired by the non-ideal characteristics of the balun (e.g. error tolerances, limited frequency range).
- Calibration can be performed at the DUT's ports. If necessary (e.g. to compensate for the effect of a test fixture), it is possible to shift the calibration plane using length offset parameters.
- Differential and common mode parameters can be evaluated with a single test setup.



With a unidirectional R&S ZND (see [Chapter 5.1.4.3, "R&S ZND: Unidirectional vs. Bidirectional Operation"](#), on page 75), balanced measurements are not possible.

5.3.6.1 Balanced Port Configurations

Defining a balanced logical port requires two physical ports.

The physical ports (on the VNA and connected [External Switch Matrices](#)) are equivalent and can be freely combined to balanced (logical) ports. Moreover, it is possible to assign arbitrary, independent reference impedance values to each unbalanced port and to the differential and common mode of each logical port.

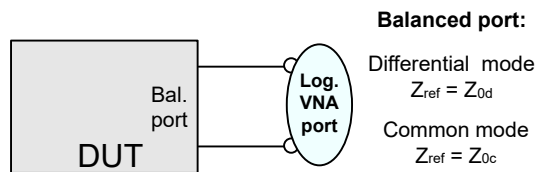
Example:**2 physical ports:** Reflection measurements on 1 balanced port**3 physical ports:** Reflection and transmission measurements on 1 balanced port**Single-ended (unbalanced) port**

$Z_{ref} = Z_{connector}$

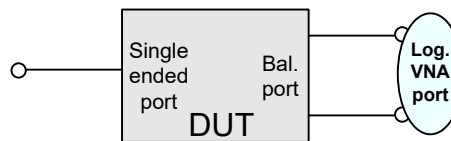
**4 physical ports:** Reflection and transmission measurements on 1 or 2 balanced ports**Single-ended (unbalanced) ports**

$Z_{ref1} = Z_{connector1}$

$Z_{ref2} = Z_{connector2}$

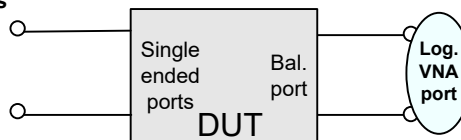
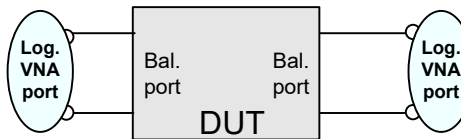
**Balanced port:**Differential mode
 $Z_{ref} = Z_{0d}$ Common mode
 $Z_{ref} = Z_{0c}$ 

A balanced port configuration is defined in two steps: First, select the pairs of physical ports that you want to combine to form balanced ports. Second, define the two reference impedances for the differential and common mode at each balanced port. Both steps can be done in a single "Balanced Ports" dialog. The most commonly used balanced port configurations and impedances are predefined and can be selected in the "S-Parameter Wizard".

The "Balanced Ports" dialog allows you to switch to balanced operation and to define the reference impedances the differential and common mode.

Depending on the test setup, the analyzer provides different types of mixed mode parameters; refer to the following sections for details.

5.3.6.2 Mixed Mode Parameters

Mixed mode parameters are an extension of normal mode parameters (e.g. S-parameters, impedances and admittances) for balanced measurements. The analyzer can measure mixed mode parameters once a balanced port configuration is selected.

Mixed mode parameters are used to distinguish the following three port modes:

- s: Single-ended (for unbalanced ports)
- d: Differential mode (for balanced ports)
- c: Common mode (for balanced ports)

The notation of a general S-parameter is $S_{\langle \text{mout} \rangle \langle \text{min} \rangle \langle \text{out} \rangle \langle \text{in} \rangle}$, where $\langle \text{mout} \rangle$ and $\langle \text{min} \rangle$ denote the output and input port modes, $\langle \text{out} \rangle$ and $\langle \text{in} \rangle$ denote the output and input port numbers.

Meaning of 2-port mixed mode S-parameters

The mixed mode 2-port S-parameters can be interpreted as follows:

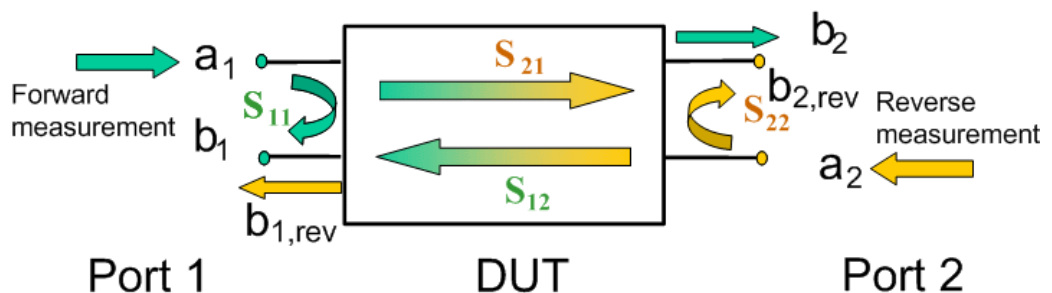

- $S_{\langle \text{mout} \rangle \langle \text{min} \rangle 11}$ is the mixed mode input reflection coefficient, defined as the ratio of the wave quantities b_1 (mode mout) to a_1 (mode min), measured at PORT 1 (forward measurement with matched output and $a_2 = 0$).
- $S_{\langle \text{mout} \rangle \langle \text{min} \rangle 21}$ is the mixed mode forward transmission coefficient, defined as the ratio of the wave quantities b_2 (mode mout) to a_1 (mode min) (forward measurement with matched output and $a_2 = 0$).
- $S_{\langle \text{mout} \rangle \langle \text{min} \rangle 12}$ is the mixed mode reverse transmission coefficient, defined as the ratio of the wave quantities b_1 (mode mout) (reverse measurement with matched input, b_1' in the figure above and $a_1 = 0$) to a_2 (mode min).
- $S_{\langle \text{mout} \rangle \langle \text{min} \rangle 22}$ is the mixed mode output reflection coefficient, defined as the ratio of the wave quantities b_2 (mode mout) (reverse measurement with matched input, b_2' in the figure above and $a_1 = 0$) to a_2 (mode min), measured at PORT 2.

If $\langle \text{mout} \rangle$ is different from $\langle \text{min} \rangle$, the S-parameters are called mode conversion factors.

Mixed Mode Parameters for Different Test Setups

Which types of mixed mode parameter are available depends on the measured device and the port configuration of the analyzer. With 4 physical test ports (on the VNA and connected [External Switch Matrices](#)), the following examples of mixed mode parameters can be measured. Without a switch matrix, only the first two examples can be measured.

1. DUT with only single-ended ports: No balanced port definition necessary, the analyzer provides single-ended multiport parameters.

2. DUT with one balanced port: Only reflection and mode conversion measurements with differential and common mode parameters.

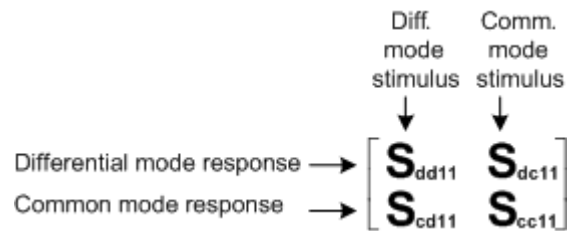

3. DUT with one balanced and one single-ended port.

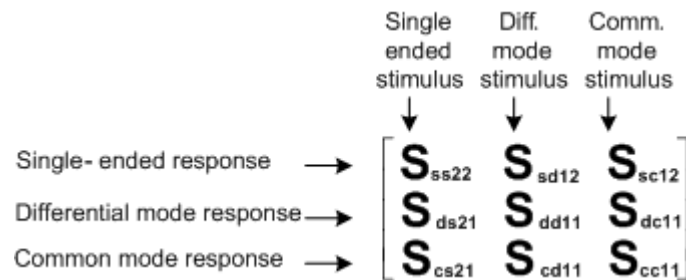

4. DUT with two balanced ports or one balanced and two single-ended ports. Both device types are fully characterized by 4x4 mixed mode S-matrices.

5.3.6.3 Imbalance and Common Mode Rejection

An ideal unbalance-balance transformer (balun) converts an unbalanced signal into a balanced one and vice versa. When it is driven with an unbalanced signal at its physical port 1 (= single-ended logical port 1), unbalanced signals with equal amplitude and opposite phase appear at physical ports 2 and 4 (forming balanced logical port 2). This means that the ratio $-S_{21}/S_{41}$ of the physical transmission coefficients of an ideal balun equals 1. This ratio is called **imbalance**; it is a measure for the deviation of the balun from ideality. The general definition of the transmission imbalance between two different ports (at least one of them balanced) is given below.

For a DUT with two balanced ports (e.g. an amplifier), the ratio between the (wanted) differential mode power gain and the (unwanted) common mode power gain is called **common-mode rejection ratio** (CMRR). It can be calculated as $|S_{dd21}|/|S_{cc21}|$ (see [Chapter 5.3.6.2, "Mixed Mode Parameters"](#), on page 117). The general definition of the complex CMRR between two ports (at least one of them balanced) is given below.



Imbalance and common-mode rejection ratio can only be measured if a [switch matrix](#) is connected and configured.

General Definition

In general, imbalance and CMRR are quantities with two numeric indices, indicating the logical output port and the logical input port of the DUT during the measurement ($\text{Imb}_{\langle\text{out}\rangle\langle\text{in}\rangle}$, $\text{CMRR}_{\langle\text{out}\rangle\langle\text{in}\rangle}$).

- DUT with single-ended logical port i and balanced logical port j:

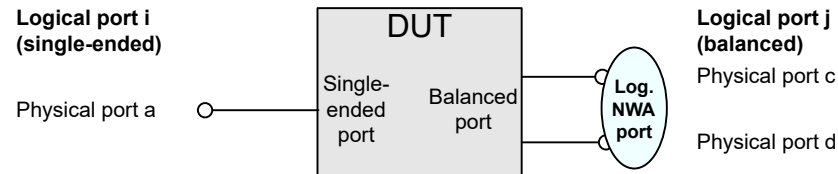

$$\begin{aligned} - \text{Imb}_{ji} &= -S_{ca}/S_{da} \text{ and } \text{Imb}_{ij} = -S_{ac}/S_{ad} \\ - \text{CMRR}_{ji} &= S_{dsji}/S_{csji} \text{ and } \text{CMRR}_{ij} = S_{sdij}/S_{scij} \end{aligned}$$

- DUT with balanced logical ports i and j:

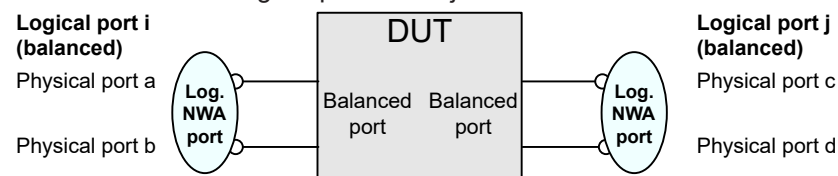

$$\begin{aligned} - \text{Imb}_{ji} &= -(S_{ca} - S_{cb})/(S_{da} - S_{db}), \text{ for } i \neq j \\ - \text{CMRR}_{ji} &= S_{ddji}/S_{ccji} \end{aligned}$$

Differential Imbalance

A (differential) imbalance can also be calculated if the second balanced DUT port is connected to two single-ended logical ports:

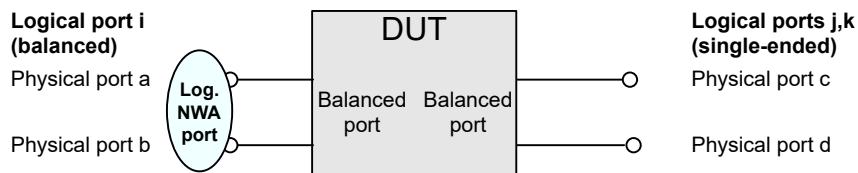

$$\text{Imb}_{jk-i} = -(S_{ca} - S_{da})/(S_{cb} - S_{db})$$

$$\text{Imb}_{i-jk} = -(S_{ac} - S_{ad})/(S_{bc} - S_{bd})$$

5.3.7 Stability Factors

The stability factors K , μ_1 and μ_2 are real functions of the (complex) S-parameters, defined as follows:

$$K := \frac{1 - |S_{11}|^2 - |S_{22}|^2 + |S_{11} \cdot S_{22} - S_{12} \cdot S_{21}|^2}{2 \cdot |S_{12} \cdot S_{21}|}$$

$$\mu_1 := \frac{1 - |S_{11}|^2}{|S_{22} - \overline{S_{11}} \cdot (S_{11} \cdot S_{22} - S_{12} \cdot S_{21})| + |S_{12} \cdot S_{21}|}$$

$$\mu_2 := \frac{1 - |S_{22}|^2}{|S_{11} - \overline{S_{22}} \cdot (S_{11} \cdot S_{22} - S_{12} \cdot S_{21})| + |S_{12} \cdot S_{21}|}$$

where \bar{S} denotes the complex conjugate of S .

Stability factors are calculated as functions of the frequency or another stimulus parameter. They provide criteria for linear stability of two-ports such as amplifiers. A linear circuit is said to be unconditionally stable if no combination of passive source or load can cause the circuit to oscillate.



For a unidirectional R&S ZND (see [Chapter 5.1.4.3, "R&S ZND: Unidirectional vs. Bidirectional Operation"](#), on page 75) stability factors are not available.

- The K-factor provides a necessary condition for unconditional stability: A circuit is unconditionally stable if $K > 1$ and an additional condition is met. The additional condition can be tested with the stability factors μ_1 and μ_2 .
- The μ_1 and μ_2 factors both provide a necessary and sufficient condition for unconditional stability: The conditions $\mu_1 > 1$ or $\mu_2 > 1$ are both equivalent to unconditional stability. This means that μ_1 and μ_2 provide direct insight into the degree of stability or potential instability of linear circuits.

References: Marion Lee Edwards and Jeffrey H. Sinsky, "A New Criterion for Linear 2-Port Stability Using a Single Geometrically Derived Parameter", IEEE Trans. MTT, vol. 40, No. 12, pp. 2303-2311, Dec. 1992.

5.3.8 Delay, Aperture, Electrical Length

The group delay τ_g represents the propagation time of wave through a device. τ_g is a real quantity and is calculated as the negative of the derivative of its phase response. A non-dispersive DUT shows a linear phase response, which produces a constant delay (a constant ratio of phase difference to frequency difference).

The group delay is defined as:

$$\tau_g = -\frac{d\phi_{rad}}{d\omega} = -\frac{d\phi_{deg}}{360^\circ df}$$

where

Φ_{rad} , Φ_{deg} = phase response in radians or degrees

ω = angular velocity in radians/s

f = frequency in Hz

In practice, the analyzer calculates an approximation to the derivative of the phase response, taking a small frequency interval Δf and determining the corresponding phase change $\Delta\Phi$. The delay is thus computed as:

$$\tau_{g,meas} = -\frac{\Delta\phi_{deg}}{360^\circ \cdot \Delta f}$$

The aperture Δf must be adjusted to the conditions of the measurement.

If the delay is constant over the considered frequency range (non-dispersive DUT, e.g. a cable), then τ_g and $\tau_{g,meas}$ are identical and:

$$\tau_g = \frac{d(360^\circ f \cdot \Delta t)}{360^\circ d f} = \Delta t = \frac{L_{mech} \cdot \sqrt{\epsilon}}{c}$$

where Δt is the propagation time of the wave across the DUT, which often can be expressed in terms of its mechanical length L_{mech} , the permittivity ϵ , and the velocity of light c . The product $L_{mech} \cdot \sqrt{\epsilon}$ is termed the electrical length of the DUT and is always larger or equal than the mechanical length ($\epsilon > 1$ for all dielectrics and $\epsilon = 1$ for the vacuum).

5.4 Operations on Traces

The R&S ZND can perform more complex operations on the measured traces. Some of the operations, e.g. the time domain transform, require additional software options; see [Chapter 5.7, "Optional Extensions and Accessories"](#), on page 191.

The R&S ZND can also check whether the measured values comply with specified limits and export trace data, using different file formats.

5.4.1 Limit Check

A limit line restricts the allowed range for some or all points of a trace, i.e. for a certain range of stimulus values. Typically, limit lines are used to check whether a DUT conforms to the rated specifications (conformance testing).

- An upper limit line defines the maximum allowed values for the related stimulus range.
- A lower limit line defines the minimum allowed values for the related stimulus range.
- A ripple limit defines the maximum difference between the largest and the smallest response value for the related stimulus range. A ripple limit test is suitable, e.g., to check whether the passband ripple of a filter is within acceptable limits, irrespective of the actual transmitted power in the passband.
- A circle limit defines the acceptable values as a circular area within a complex diagram.

A limit check consists of comparing the measurement results to the limit lines and display a pass/fail indication. An acoustic warning and a TTL signal at the USER PORT on the rear panel (for test automation) can be generated in addition if a limit is violated.

Upper and lower limit lines are both defined as a combination of segments with a linear or logarithmic dependence between the measured quantity and the sweep variable (stimulus variable). Similar to this segmentation, ripple limits can be defined in several ranges. The limit lines (except circle limits) can be stored to a file and recalled. Data or memory traces can be used to define the segments of an upper or lower limit line. Moreover it is possible to modify the upper and lower limit lines globally by adding an offset to the stimulus or response values.

5.4.1.1 Rules for Limit Line Definition

The analyzer places few restrictions on the definition of limit line segments.

The following rules ensure a maximum of flexibility:

- Segments do not have to be sorted in ascending or descending order (e.g. the "Start Stimulus" value of segment no. n does not have to be smaller than the "Start Stimulus" value of segment no. $n+1$).
- Overlapping segments are allowed. The limit check in the overlapping area is related to the tighter limit (the pass test involves a logical AND operation).
- Gaps between segments are allowed and equivalent to switching off an intermediate limit line segment.
- Limit lines can be partially or entirely outside the sweep range, however, the limits are only checked at the measurement points.

The following figure shows a limit line consisting of 3 upper and 2 lower limit line segments. To pass the limit check, the trace must be confined to the shaded area.

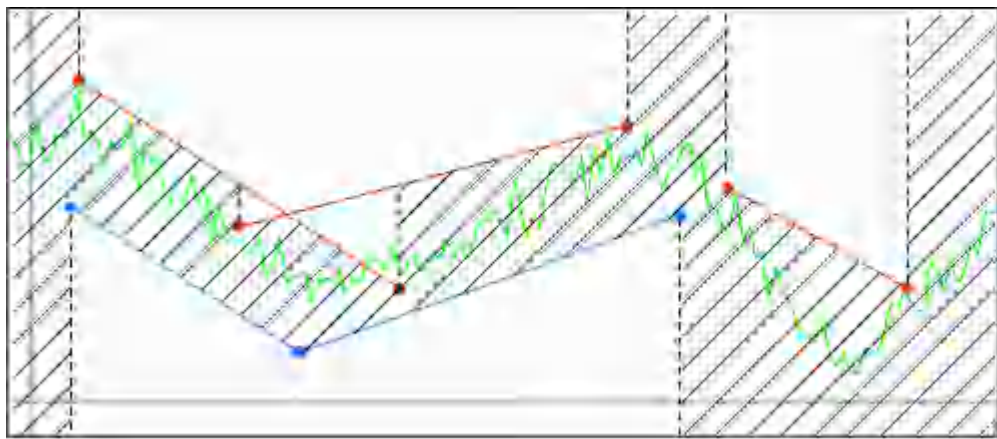

As a consequence of the limit line rules, a DUT always passes the limit check if no limit lines are defined.



Formula-defined limit lines

A limit line doesn't have to be straight. You can also use a custom formula to define it.

When the sweep axis is changed from linear frequency sweep to logarithmic sweeps, straight limit lines are transformed into exponential curves. The sweep points are redistributed along the x-axis, so the number of failed points can change.

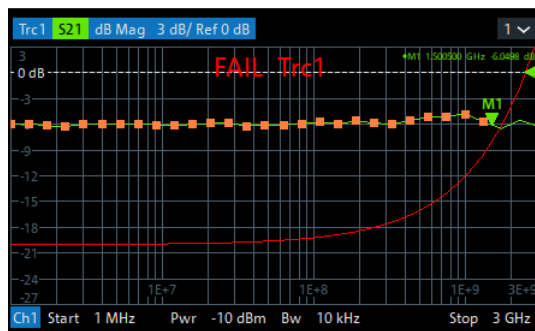

Logarithmic interpolation

The analyzer offers a logarithmic interpolation mode that allows you to carry over the limit line definition to logarithmic sweeps.

While "Show Limit Line" is active, the diagrams display all limit line segments.

Exception: In a segmented frequency sweep with point-based x-axis, gaps between the segments are minimized. To facilitate the interpretation, the R&S ZND displays only the limit line segments which provide the limit check criterion (the "tighter" limit line at each point). In the example below, this rule results in a single, continuous lower limit line.

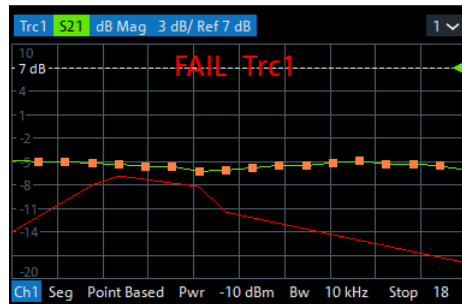

5.4.1.2 Rules for Ripple Test Definition

The analyzer places few restrictions on the definition of ripple limit ranges.

The following rules ensure a maximum of flexibility:

- Ranges do not have to be sorted in ascending or descending order (e.g. the "Start Stimulus" value of range no. n does not have to be smaller than the "Start Stimulus" value of range no. n+1).
- Overlapping ranges are allowed. The limit check in the overlapping area is related to the tighter limit (the pass test involves a logical AND operation).
- Gaps between ranges are allowed and equivalent to switching off an intermediate ripple limit range.
- Ripple limit ranges can be partially or entirely outside the sweep range, however, the limits are only checked at the measurement points.

The following figure shows a ripple limit test involving 3 active ranges.

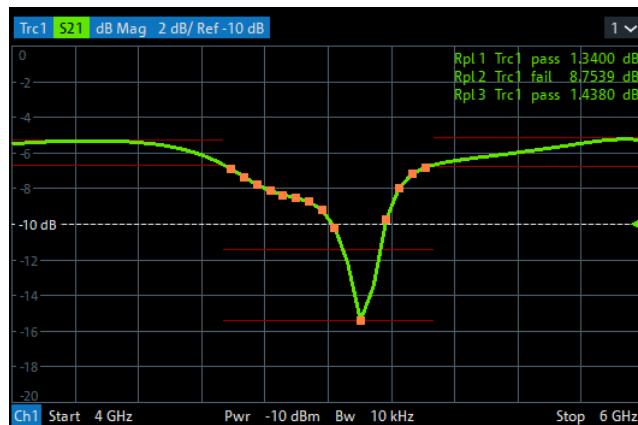

The limit line rules for logarithmic sweeps and segmented frequency sweeps with point-based x-axis also apply to ripple limit lines (see [Chapter 5.4.1.1, "Rules for Limit Line Definition"](#), on page 123).

5.4.1.3 Circle Limits

A circle limit is a special type of **upper** limit line which is defined by its center coordinate in the diagram and its radius. Depending on the diagram type, circle limit can serve different purposes:

- With a circle limit line centered on the origin of a polar diagram, you can check whether the magnitude of the measurement results exceeds a limit, defined by the radius of the limit line.

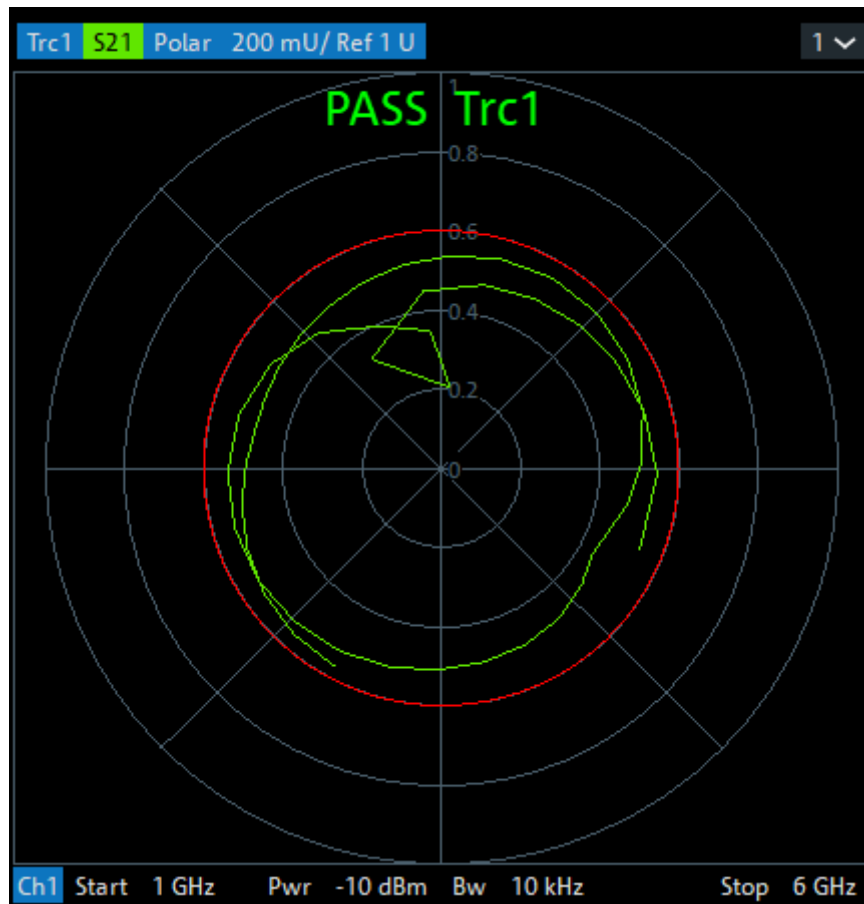

- With a circle limit line adjusted to the right border of a Smith diagram ($Z = \text{infinity}$), you can check whether the imaginary part of the impedance ($\text{Im}(Z)$, reactance) falls below a limit.

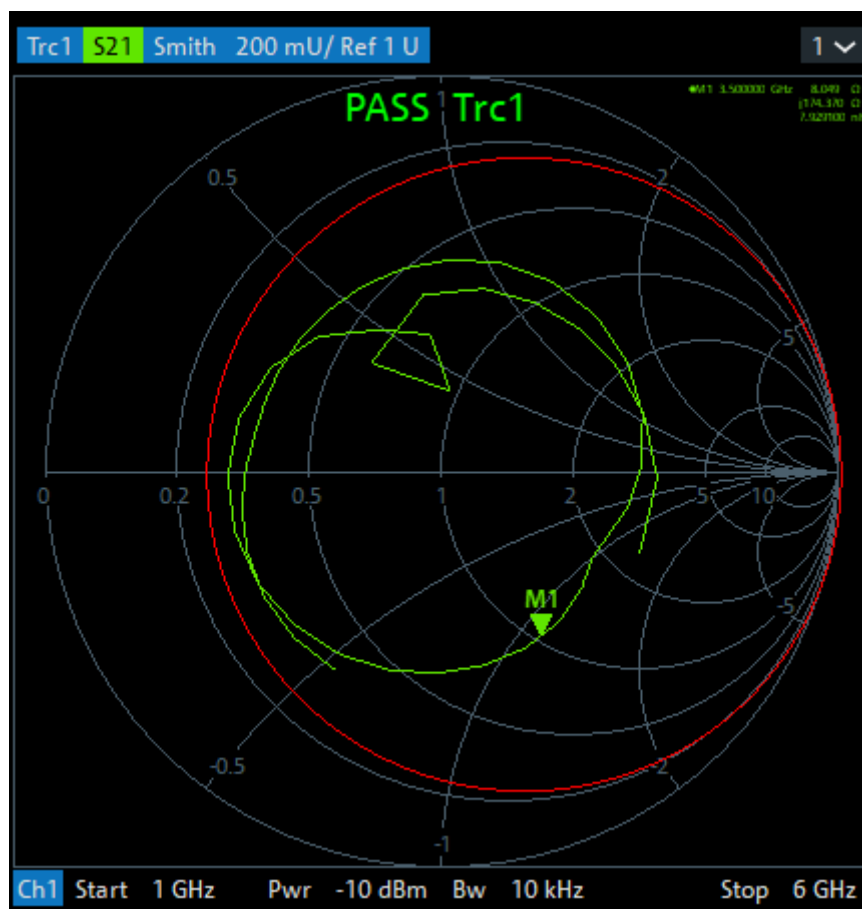

- With a circle limit line centered on the left border of an inverted Smith diagram ($Y = \infty$), you can check whether the imaginary part of the admittance ($\text{Im}(Y)$, susceptance) falls below a limit.

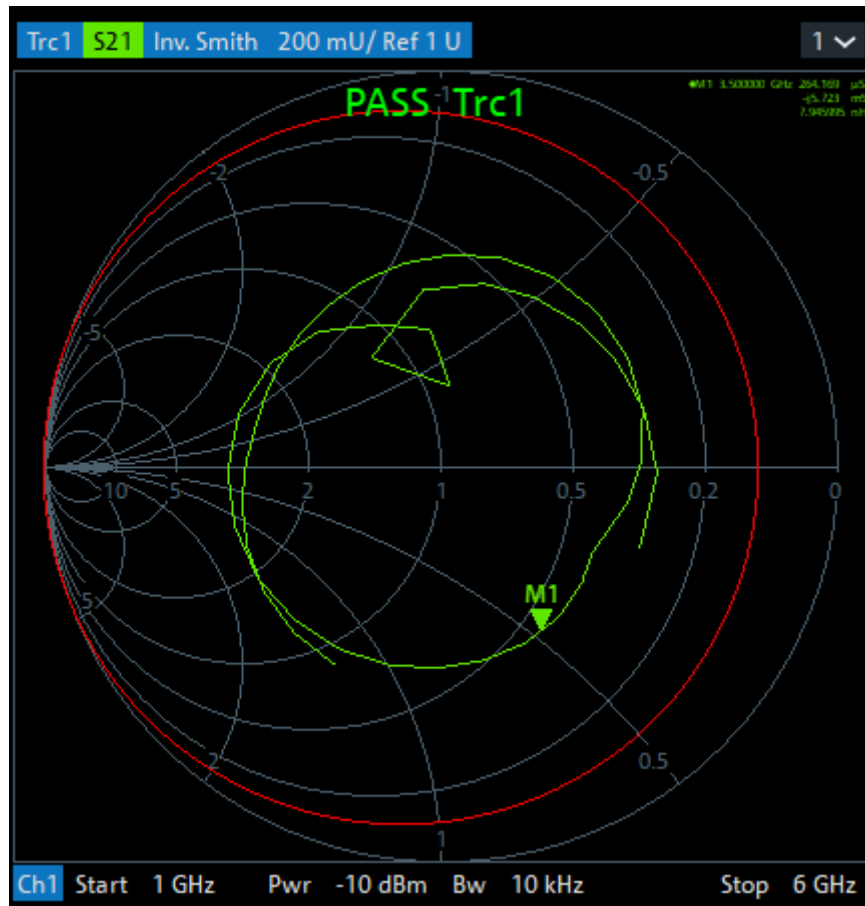

5.4.1.4 File Format for Limit Lines

The analyzer uses a simple ASCII format to export limit line data. By default, the limit line file has the extension *.limit and is stored in the directory shown in the "Save Limit Line" and "Recall Limit Line" dialogs. The file starts with a preamble containing the channel and trace name and the header of the segment list. The following lines contain the entries of all editable columns of the list.

Example of a limit line file

The limit line:

#	Type	Start Stimulus	Stop Stimulus	Start Response	Stop Response
1	Upper	9 kHz	8.5 GHz	0 dB	0 dB
2	Lower	9 kHz	6 GHz	-20 dB	-10 dB
3	Off	6 GHz	8.5 GHz	-10 dB	-10 dB

is described by the limit line file:

```
# Version 1.00
# Channel 1
# Trace 1
en:Type,Start Stimulus[MHz],Stop Stimulus[MHz],Start Response[dB],Stop Response[dB],
Upper,8.999999999999999E-003,8.500000000000000E+003,0.000000000000000E+000,0.000000000000000E+000,
Lower,8.999999999999999E-003,6.000000000000000E+003,-2.000000000000000E+001,-1.000000000000000E+001,
Off,6.000000000000000E+003,8.500000000000000E+003,-1.000000000000000E+001,-1.000000000000000E+001,
```



Compatibility with other instruments

The VNAs of the R&S ZNx and R&S ZVx families use the same file format. Limit line files can be interchanged without restriction.

5.4.1.5 File Format for Ripple Limits

The analyzer uses a simple ASCII format to export ripple limits. By default, the ripple limit file has the extension `*.ripple` and is stored in the directory shown in the "Save Ripple Limits" and "Recall Ripple Limits" dialogs. The file starts with a preamble containing the channel and trace name and the header of the range list. The following lines contain the entries of all editable columns of the list.

Example of a ripple limit file

The ripple limit list:

	Range On/Off	Start Stimulus	Stop Stimulus	Ripple Limit
1	<input checked="" type="checkbox"/>	3 GHz	5 GHz	12 dB
2	<input checked="" type="checkbox"/>	4.5 GHz	5.5 GHz	5 dB
3	<input type="checkbox"/>	5.5 GHz	6 GHz	4.3826 dB

is described by the ripple limit file:

```
# version 1.00
#
# Channel 1
# Trace 1
bo:Range on/off,start stimulus[MHz],stop stimulus[MHz],Ripple Limit[dB],
true,3.000000000000000E+003,5.000000000000000E+003,1.200000000000000E+001,
true,4.500000000000000E+003,5.500000000000000E+003,5.000000000000000E+000,
false,5.500000000000000E+003,6.000000000000000E+003,4.382581058243317E+000,
```



Compatibility with other instruments

The VNAs of the R&S ZNx and R&S ZVx families use the same file format. Ripple limit files can be interchanged without restriction.

5.4.2 Trace Files

The R&S ZND can store one or several data or memory traces to a file or load a memory trace from a file.

Trace files are ASCII files with selectable file format. The analyzer provides several types of trace files:

- Touchstone (*.s<n>p) files
- ASCII (*.csv) files
- Matlab (*.dat) files are ASCII files which can be imported and processed in Matlab.

The trace file formats complement each other; see [Chapter 5.4.2.3, "Finding the Best File Format"](#), on page 138.



- When exporting traces to a file, it is recommended to set the analyzer to single sweep mode (CHANNEL – [SWEEP] > "Sweep Control" > "All Channels on Hold"). This mode ensures that a complete sweep is exported.
- The number of decimal places of stimulus and data values in export files is configurable.

5.4.2.1 Touchstone Files

The Touchstone file format is a standard for the transfer of frequency-dependent network data. Based on information from Agilent Corporation (the originator of Touchstone), formal specifications were produced by the EIA/IBIS Open Forum.

- [Touchstone File Format Specification Rev 1.1](#)
- [Touchstone File Format Specification Version 2.0](#)

The R&S ZND supports Touchstone file versions 1.1 and 2.0.

By convention, Touchstone files use file extensions `.snp`, where `n` is the number of network ports. The following displays an `s1p` export file in "Version 1.1 (ZNx)" format:

```

1 # HZ S RI R 50.00
2 ! Rohde & Schwarz Vector Network Analyzer
3 ! Rohde-Schwarz, ZND-2Port, 1328517092100019, 3.20
4 ! Created: UTC 12/24/2020, 5:20:26 PM
5 ! My Comment
6 ! freq[Hz] re:S11 im:S11
1.0000000000000000E5 -4.797521848131441E-1 3.884969211858050E-2
4.2599500000000000E7 -4.775411290143956E-1 3.449207594050335E-2
...

```

- 1 = option line
- 2 = VNA identification comment
- 3 = timestamp comment
- 4 = user-defined comment
- 5 = network data table header comment
- 6 = network data table

General Syntax Rules

Among others, the following general syntax rules apply:

- Touchstone files are ASCII files, 8-bit encoded using ISO/IEC 8859-1:1998. Only the graphical characters 0x20 to 0x7E, the tab character 0x09, and the three line termination sequences LF (0x0A), CR+LF (0x0D + 0x0A), and CR (0x0Dh) are allowed.
- Touchstone files are case-insensitive.
- Blank lines are permitted.

Option Line

Each Touchstone file must contain an option line with the following structure:

```
# <frequency unit> <parameter> <data format> R <reference
resistance>
```

- # indicates the beginning of the option line
- <frequency unit> can be either Hz, kHz, MHz or GHz. Default is GHz. The R&S ZND always uses HZ for exported data.
- <parameter> specifies what kind of network parameter data is contained in the file. Default is S for S-parameters, which is the only parameter type the R&S ZND supports.
- <data format> specifies how the complex network parameter data are formatted. Possible values are RI for "Real-Imag", MA for "Lin Mag-Phase", and DB for "dB Mag-Phase". Default is MA.
According to the Touchstone file standards, $\text{dB Mag} = 20 \times \log_{10}\text{Mag}$, and the phase is always represented in degrees.
During data export, the analyzer allows you to select the suitable <data format>.
- <reference resistance> specifies the impedance system underlying the network data, given as a real, positive resistance. Its value is given in Ω (default 50). During export, if the impedances of all involved ports are identical, the analyzer sets the <reference resistance> to the real part of this impedance. Otherwise it sets it to 50.

With the exception of the opening # symbol and the value following R, option line parameters can appear in any order. If a parameter is missing, the default value is assumed.

Comments

Comments can be used for any kind of documentation purpose, e.g. to describe the network parameter data and how they were generated.

Syntactically, comments are preceded by an exclamation mark and terminated by a line termination sequence (see "[General Syntax Rules](#)" on page 130). They can appear anywhere in the file, either on a separate line, or after the parsed content of a line. Any number of comment lines can be inserted.

The content of the comments is not standardized in any way. The following sections describe the comments the R&S ZND inserts into a Touchstone file during export.



During import, the R&S ZND ignores all comments.

VNA identification

These comment lines identify the VNA that was used to generate the file.

```
! Rohde & Schwarz Vector Network Analyzer
! Rohde-Schwarz,ZND-2Port,1328517092100019,3.20
```

The first line is fixed, the second reflects the configurable identification string of the instrument.

Timestamp

The timestamp comment line reflects the time at which the Touchstone file was created. For "Version 1.1 (ZNX)" export format, it is represented as Coordinated Universal Time (UTC):

```
! Created: UTC 12/24/2020, 5:20:26 PM
```

The other export formats "Version 1.1" and "Version 2.0" use local time (Greenwich Mean Time + offset):

```
! Created: GMT+1 2020-12-24 18:20:26
```

Renormalization information

If, during export, the S-parameter data were renormalized with port-specific impedances, these impedances are written to the output file as a comment. In case the port-specific impedances are different, a note points out that the impedance system underlying the data is not interpreted correctly during import:

```
! The following Port Impedance Renormalization has been used when saving the data.
! PortZ Port1:100+j0 Port2:50+j0
!
! Note: The Port Impedances differ from the reference impedance of this file.
!       While reading the file the reference impedance value of the option line above
!       is always used.
```

For more information, see ["Renormalization of S-Parameters"](#) on page 136.



For the "Version 2.0" export format, the port impedances are currently not written to the renormalization information comment. Instead, the real parts of the port impedances appear as arguments of the [Reference] [keyword](#).

Network data table header

These comment lines indicate the content of the [Network Parameter Data](#) table right below it.

As the first column of the data table is always designated to the frequency points, the first table header comment always starts with `! freq[Hz]`.

- **"Version 1.1 (ZNX)" export format**

For this format, the header explicitly specifies the exported parameters and their data format. The port numbers of single-ended S-parameters in the header are the "real" (physical) port numbers:

```
! freq[Hz] re:S22 im:S22 re:S12 im:S12 re:S21 im:S21 re:
S11 im:S11
```

Up to port reordering, which is possible via "snp free config" export and via logical port assignment, the order in which the parameter data occur is the one described in the Touchstone 1.1 standard. See ["Network Parameter Data"](#) on page 134.

If balanced (and mixed mode) parameters are exported, the assigned logical port numbers are used:

```
! freq[Hz] re:Sdd11 im:Sdd22 re:Scd22 im:Scd22 re:Sdc22 im:
Sdc22 re:Sc22 im:Sc22
```

- **"Version 1.1" and "Version 2.0" export formats**

These export formats always use single-ended identifiers S_{ij} and port numbers 1 to n in the table header.

```
! freq[Hz] S11[Re] S11[Im] ...
```

The mapping between nominal (single-ended) and actual – possibly balanced – ports is given in the [port assignments](#) comments.

Port assignments (Version 1.1 and Version 2.0)

For export format "Version 1.1 (ZNx)", the assignments are given in the [Network data table header](#) comment lines. For export formats "Version 1.1" and "Version 2.0", they are declared in a dedicated comments section:

```
! Port Assignments:
! Nominal Port -> Actual Test Port
! -----
!   1 -> 2
!   2 -> 1
```

For balanced ports, the port assignment looks like in the following example:

```
! Port Assignments:
! Nominal Port -> Actual Test Port
! -----
!   1 -> D1,2
!   2 -> C1,2
```

The "s1p Active Trace" export, which allows to dump an arbitrary S-parameter trace to an s1p file, explicitly mentions the exported parameter:

```
! Trace info:
! Nominal Param -> Actual Exported Buffer
! -----
! S11 -> S21
```

User comment

The analyzer's trace export function allows you to insert a custom comment line into the export file.

```
! My Comment
```

Keywords (Version 2.0 Only)

Keywords are enclosed in square brackets, “[” and “]”, and start at the beginning of a line. Arguments after keywords (if any) are separated from the closing bracket and from each other by at least one blank (or tab).

```
[Keyword] argument1 argument2 ...
```



Keywords are new in Touchstone standard version 2.0. They are not allowed in version 1.1 files.

The purpose of the keywords is to give more details about the file contents in a standardized way. During "Version 2.0" export, the R&S ZND writes the following keywords to the generated Touchstone file:

Keyword	Example	Description
[Version]	[Version] 2.0	Specification version, typically the first line in the file Currently only 2.0 is allowed
[Number of Ports]	[Number of Ports] 2	The <i>n</i> in the generated <code>snp</code> file. Except for the "s1p Active Trace" export, <i>n</i> equals the number of physical ports involved in the export.
[Two-Port Data Order]	[Two-Port Data Order] 21_12	Specifies the data order in <code>s2p</code> files. <ul style="list-style-type: none"> • 21_12 indicates data order <code>f N11 N21 N12 N22</code> • 12_21 indicates data order <code>f N11 N12 N21 N22</code> (see "Data arrangement" on page 135) The R&S ZND generates <code>s2p</code> files with fixed data order 21_12 (according to the TS1.1 standard).
[Number of Frequencies]	[Number of Frequencies] 201	Number of exported frequency sweep points; can also be derived from the Network Parameter Data block.
[Reference]	[Reference] 50 75	If the exported S-parameter data were renormalized with port-specific impedances, the real parts of these impedances are listed as arguments of the [Reference] keyword. Overrides the common reference impedance of the "Option Line" on page 130 Note: currently ignored during import
[Mixed-Mode Order]	[Mixed-Mode Order] D1,2 C1,2	Required if a balanced port is involved. In the example to the left, nominal port 1 is the differential mode and nominal port 2 is the common mode of balanced port (1,2). Conveys the same information as the Port assignments (Version 1.1 and Version 2.0) comment
[Network Data]	[Network Data] ! no args	Marks the begin of the Network Parameter Data block
[End]	[End] ! no args	Marks the end of the network parameter data section and is typically placed in the last line of the export file

For details and more keywords, see the Touchstone File Format Specification Version 2.0 (http://www.ibis.org/touchstone_ver2.0/touchstone_ver2_0.pdf).



During import, the R&S ZND currently only considers the [Two-Port Data Order].

Network Parameter Data

The network parameter data section contains one block of network parameters per frequency point. Each block is preceded by a frequency value, i.e. the first entry in the

first (or only) data line of a data block is a frequency value. The complex network parameter data is formatted as pairs of values. The following general rules apply

- Individual entries in a network data line are separated by whitespace
- In version 1.1 files, no more than four parameters are allowed per network data line. No restriction exists on the number of data pairs on a line in version 2.0 files.
- The network data blocks are arranged in ascending order of frequency



For segmented sweeps, the R&S ZND makes an exception to the strict "ascending order" principle. During export, the segments are always kept together, which can result in downward "frequency jumps" at segment borders.

Data arrangement

During export, for each block the R&S ZND arranges the frequency value f and network parameter data $(N_{ij})_{1 \leq i, j \leq n}$ as described in the Touchstone 1.1 standard.

- **n = 1**
f N11
- **n = 2**
f N11 N21 N12 N22
- **n = 3, 4**
f N11 N12 N13
N21 N22 N13
N31 N32 N33

Similar matrix arrangement for $n=4$.

- **n > 4**
For $n > 4$, the "max. four parameters per data line" restriction applies. It is overcome by wrapping the matrix row at multiples of four network parameter values. For $n = 9$ this logic results in the following arrangement:
f N11 N12 N13 N14
N15 N16 N17 N18
N19
N21 ...
N95 N96 N97 N98
N99

The data blocks are arranged in ascending order of frequency.

Data format

Frequencies are represented as single positive numbers, network parameter data as pairs of numbers. The `<frequency unit>` and `<data format>` are specified in the [Option Line](#). Numbers can be represented as decimal integers or floating point numbers, with "." used as decimal separator. Scientific notation is allowed (e.g., $1.2345e-12$). No minimum or maximum limits are placed on numerical precision.

For Touchstone export, the R&S ZND uses the normalized scientific notation, with a significand (mantissa) of length 17 (+1 for the minus sign) and an exponent with maximum length 2 (+1 for the minus sign).

1.0000000000000000e+09	-2.375070438098596e-01	-4.533104459856211e-01
1.0100000000000000e+09	-3.132740349817996e-01	-5.874596585157938e-01
1.0200000000000000e+09	-3.062444919836442e-01	-4.587379501906624e-01

Conditions for Touchstone File Export

- One-port Touchstone files with data from a single trace
Typically, Touchstone files contain a complete set of S-parameter traces of an n-port network. The only exceptions are `s1p` files created from arbitrary S-parameter traces using the "s1p Active Trace" export function in the [Trace Data Tab](#) or the remote command `MMEMoRY:STORe:TRACe`.
- Touchstone files containing S-matrices
 - For a one-port Touchstone file, the reflection coefficient for the specified port (S_{ii} for port i) must be measured. If a full one-port (Refl OSM) or a full n-port (TOSM, ...) calibration is available for the specified port, it is possible to export the data even when the trace is not displayed.
 - For a multiport Touchstone file `*.s<n>p`, either a full multiport system error correction or a complete set of n^2 S-parameter traces must be available. If the port configuration contains balanced ports, the exported Touchstone file contains the converted single-ended S-parameters unless you enable "Balanced Params" during export.
 - Export of balanced (symmetric) S-parameters must be enabled. If you want to export balanced S-parameters, make sure that all these parameters are measured, and that for each involved balanced port both physical ports are part of the export.

This type of export can be initiated from the GUI by using the "`s<n>p Port ...`" or "`snp Free Config. ...`" functions of the [Trace Data Tab](#) or by the remote command `MMEMoRY:STORe:TRACe:PORTs` on page 877.



For a unidirectional R&S ZND (see [Chapter 5.1.4.3, "R&S ZND: Unidirectional vs. Bidirectional Operation"](#), on page 75) the S-parameters S_{i2} cannot be measured and hence an export to `*.s2p` file is not available. However, you can *import* S-parameter traces from arbitrary `*.snp` files.

Renormalization of S-Parameters

Renormalization means that the S-parameters at connector impedances are converted to S-parameters at certain target impedances.

During Touchstone export, the S-parameters can be renormalized in two ways:

- Common target impedance
The `<reference resistance>` of the [Option Line](#) is taken as common target impedance and the data is renormalized to the common target impedance, regardless of the reference impedances of the involved ports.
If the impedances of all involved ports are identical, the analyzer sets the `<reference resistance>` in the [Option Line](#) to the real part of this impedance. Otherwise it sets it to 50 (Ω).
- Port-specific [Reference Impedances](#)

In this case, the reference impedances of the individual ports are used for the renormalization and these impedances are documented in the [Renormalization information](#) comment. If the port-specific reference impedances are different, an additional warning is added to this comment, indicating that the option line contains a non-matching reference resistance.

Note that when reimporting this type of file into standard applications (including the R&S ZND itself), the `<reference resistance>` of the Touchstone option line is used and the impedance system underlying the data is not interpreted correctly.

5.4.2.2 ASCII (*.csv) Files

An ASCII file contains a header and the actual trace data:

```
freq;reTrc1_S21;imTrc1_S21;reMem2[Trc1_S21;imMem2[Trc1_S21;
300000.000000;0.000000;0.000000;0.000000;0.000000;
40499497.487437;0.000000;0.000000;0.000000;0.000000;
80698994.974874;0.494927;-0.065174;0.500833;-0.074866;
120898492.462312;0.497959;-0.111724;0.488029;-0.107375;
...
```

The header consists of the following data elements:

- `<Stimulus>` stimulus variable: freq for Frequency sweep, power for Power sweep, time for Time sweep, trigger for CW Mode sweep.
- `<reTrace1>` first response value of first trace: re`<Trace_Name>`, mag`<Trace_Name>` or db`<Trace_Name>` for output format Re/Im, lin. Mag-Phase or dB Mag-Phase, respectively. The data format for export files can be selected in the Export Data dialog.
- `<imTrace1>` second response value of first trace: im`<Trace_Name>` for output format Re/Im, ang`<Trace_Name>` for output formats lin. Mag-Phase or dB Mag-Phase. The data format for export files can be selected in the Export Data dialog.
- `<reTrace2>` first response value of second trace: re`<Trace_Name>`, mag`<Trace_Name>` or db`<Trace_Name>` for output format Re/Im, lin. Mag-Phase or dB Mag-Phase, respectively. The data format for export files can be selected in the Export Data dialog.
- `<imTrace2>...` second response value of second trace: im`<Trace_Name>` for output format Re/Im, ang`<Trace_Name>` for output formats lin. Mag-Phase or dB Mag-Phase. The data format for export files can be selected in the Export Data dialog. first response value of second trace. HZ / KHZ / MHZ / GHZ allowed for imported files. The analyzer always uses HZ for exported data. second response value of first trace: im`<Trace_Name>` for output format Re/Im, ang`<Trace_Name>` for output formats lin. Mag-Phase or dB Mag-Phase. The data format for export files can be selected in the Export Data dialog.

The trace data is arranged as described in the header. Different values are separated by semicolons, commas or other characters, depending on the selected "Decimal Separator" in the "Export ... Data" dialogs. A semicolon is inserted before the end of each line.

The stimulus values are arranged in ascending order.

5.4.2.3 Finding the Best File Format

The file format depends on how you want to use the exported data.

Use a **Touchstone** file format to export S-parameter data traces to a file that can be evaluated with applications such as Keysight's Advanced Design System (the former Microwave Design System), and to convert mixed mode parameters back to single-ended parameters. The data must be acquired in a frequency sweep. Note the "[Conditions for Touchstone File Export](#)" on page 136.



Touchstone files cannot be used to export mathematical traces.

Use the **ASCII (*.csv)** format if you want to do one of the following:

- Import the created file into a spreadsheet application such as Microsoft Excel.
- Export an arbitrary number of traces, multiple traces with the same parameter or memory traces.
- Export traces acquired in a power sweep or CW sweep.
- Use export options.

Use the **Matlab (*.dat)** format if you want to import and process the trace data in Matlab.

5.4.3 Memory-Mapped Trace Data Transfer

The VNA firmware uses the *Named Shared Memory Windows* feature to share trace data with other processes running on the instrument. Such processes or applications can read trace data directly from the shared memory, which is much faster than using SCPI commands.

Multiple traces can be written to the same shared memory buffer. For each of these traces, the firmware stores a configurable number of formatted or unformatted trace values to a contiguous part of the shared memory.

- A formatted (real) trace value takes up 8 bytes of memory.
- An unformatted (complex) trace value takes up 16 bytes: 8 bytes for the real part, 8 bytes for the imaginary part.

Memory-mapped trace data transfer is a pure remote control feature. Once set up, the VNA firmware refreshes the shared memory trace data with every sweep. Other processes can read these data via standard APIs for *Windows Named Shared Memory* that are available for various programming languages.



You can create multiple shared memory buffers, e.g. with different intended life span.

Set up a shared memory buffer

The setup of a shared memory buffer and the allocation of trace data is performed by a sequence of `SYSTem:DATA:MEMory...` commands, starting with an `INITialize` and finished by a `COMMit`.

1. Initialize the shared memory buffer:

```
SYSTem:DATA:MEMory:INITialize
```

2. Add traces:

- a) `SYSTem:DATA:MEMory:ADD '<TrName1>', FDATA|SDATa, #Values1`

Select an existing trace name, choose whether to use formatted trace data (FDATa) or unformatted trace data (SDATa), and define how many trace values the firmware writes to the buffer per sweep.

The data block of the first trace has an offset of 0 bytes relative to the start of the shared memory buffer.

- b) `SYSTem:DATA:MEMory:ADD '<TrName2>', FDATA|SDATa, #Values2`

Use `SYSTem:DATA:MEMory:OFFSet?` to query the offset in bytes of the second trace data block. Processes that want to read the trace data from the buffer need to know this offset. Its size depends on whether the first trace data block contains formatted (real) or unformatted (complex) values.

- c) ...

Use `SYSTem:DATA:MEMory:OFFSet?` to query the offset of the last added trace.

3. Create the named shared memory buffer:

```
SYSTem:DATA:MEMory:COMMit '<ShMemName>'
```

The name must be unique. Before the `COMMit` you can use `SYSTem:DATA:MEMory:CATalog?` to query the names of existing shared memory buffers.

The size of the last created shared memory buffer can be queried using `SYSTem:DATA:MEMory:SIZE?`.

Use a shared memory buffer

After you have created a named shared memory buffer, you can access it – from the instrument – using your favorite programming language and API. With Python, for instance, you can use the `mmap` module for this purpose.

Delete a shared memory buffer

To delete a shared memory buffer and free the occupied memory, you can use one of the following commands.

1. `SYSTem:DATA:MEMory:DELeTe '<ShMemName>'`
deletes a single shared memory buffer by name.
2. `SYSTem:DATA:MEMory:RESet`
deletes all shared memory buffers created using `SYSTem:DATA:MEMory:COMMit`.

5.5 Calibration

Calibration or system error correction is the process of eliminating systematic, reproducible errors from the measurement results (S-parameters and derived quantities; see [Chapter 5.1.5, "Data Flow"](#), on page 77). The process involves the following stages:

1. A set of calibration standards is selected and measured over the required sweep range.
For many calibration types, the magnitude and phase response of each calibration standard (i.e. its S-parameters if no system errors occur) must be known within the entire sweep range. In some calibration procedures (TRL, TNA, TRM), part of the characteristics of the standards can be auto-determined due to implicit redundancy (self-calibration).
2. The analyzer compares the measurement data of the standards with their known, ideal response. The difference is used to calculate the system errors using a particular error model (calibration type) and derive a set of system error correction data.
3. The system error correction data is used to correct the measurement results of a DUT that is measured instead of the standards.

Calibration is always channel-specific because it depends on the hardware settings, in particular on the sweep range. This means that a system error correction data set is stored with the calibrated channel.

The analyzer provides a wide range of sophisticated calibration methods for all types of measurements. Which calibration method is selected depends on the expected system errors, the accuracy requirements of the measurement, on the test setup and on the types of calibration standards available.

Due to the analyzer's calibration wizard, calibration is a straightforward, menu-guided process. Moreover, it is possible to perform the entire calibration process automatically using a Calibration Unit (e.g. R&S ZN-Z5x or R&S ZN-Z15x).



The system error correction data determined in a calibration procedure are stored on the analyzer. You can read these correction data using the remote control command `[SENSe<Ch>:]CORRection:CDATa`. You can also replace the correction data of the analyzer by your own correction data sets.



Cal Off label

A label "Cal Off" appears in the trace line if the system error correction no longer applies to the trace:

Trc1 S21 dB Mag 10 dB/ Ref 0 dB Cal Off

This can happen for one of the following reasons:

- The sweep range is outside the calibrated frequency range.
- The channel calibration is not sufficient for the measured quantity (e.g. a one-port calibration has been performed, but the measured quantity is a transmission parameter).
- The system error correction has been switched off deliberately ("User Cal Active" is disabled).

The analyzer provides other labels to indicate the status of the current calibration; see [Chapter 5.5.4, "Calibration Labels"](#), on page 158.



Calibration and port de-/activation

The analyzer firmware automatically activates/deactivates ports during/after a (successful) calibration:

- Calibrated ports that were previously disabled, are automatically enabled as single-ended logical ports.
- An uncalibrated port that is not used by a measurement (i.e. the port is not required by any trace of the related channel) is disabled.

5.5.1 Calibration Types

The analyzer provides a wide range of calibration types for one, two or more ports. The calibration types differ in the number and types of standards used, the error terms, i.e. the type of systematic errors corrected and the general accuracy. The following table gives an overview.

Table 5-7: Overview of calibration types

Calibration Type	Standards	Parameters	Error Terms	General Accuracy	Application
Reflection Normalization	Open or Short	S_{ii} for Port i	Reflection tracking	Low to medium	Reflection measurements on any port.
Transmission Normalization	Through	S_{ij} for port pair (i,j) , $i \neq j$	Transmission tracking	Medium	Transmission measurements in any direction and between any combination of ports.
Reflection OSM	Open, Short, Match ¹⁾	S_{ii} for Port i	Reflection tracking, Source match Directivity,	High	Reflection measurements on any port.

Calibration Type	Standards	Parameters	Error Terms	General Accuracy	Application
One Path Two Ports	Open, Short, Match ¹⁾ (at source port), Through ²⁾ between the source port and all target ports	S_{tj} for fixed source port j and target ports t	Reflection tracking, Source match, Directivity, Transmission tracking	Medium to high	Unidirectional transmission measurements in any direction and between any combination of ports.
TOSM or UOSM (2-port)	Open, Short, Match ¹⁾ (at each port), Through ²⁾ (between all port pairs)	All	Reflection tracking, Source match, Directivity, Load match, Transmission tracking,	High	Reflection and transmission measurements; classical 12-term error correction model.
Adapter Removal (2-port)	Open, Short, Match ¹⁾ (at each port), Through	All Reflection parameters with and without adapter	Reflection tracking, Source match, Directivity, Load match, Transmission tracking,	High	Reflection and transmission measurements; classical 12-term error correction model.
TOM (2-port)	Open, Match (at both ports), Through (between all port pairs)	All	Reflection tracking, Source match, Directivity, Load match, Transmission tracking	High	Reflection and transmission measurements.
TSM (2-port)	Short, Match (at both ports), Through (between all port pairs)	All	Reflection tracking, Source match, Directivity, Load match, Transmission tracking	High	Reflection and transmission measurements.
TRM (2-port)	Reflect (equal at both ports), Match, Through (between all port pairs)	All	Reflection tracking, Source match, Directivity, Load match, Transmission tracking	High	Reflection and transmission measurements, especially in test fixtures.
TRL (2-port)	Reflect (at both ports), Through, Line1, other Lines (optional), combination with TRM (optional)	All	Reflection tracking, Source match, Directivity, Load match, Transmission tracking	High, high directivity	Reflection and transmission measurements, especially for planar circuits. Limited bandwidth.

Calibration Type	Standards	Parameters	Error Terms	General Accuracy	Application
TNA (2-port)	Through, Attenuation, Symmetric network	All	Reflection tracking, Source match, Directivity, Load match, Transmission tracking	High, lowest requirements on standards	Reflection and transmission measurements, especially for planar circuits.
<p>¹⁾ Or any other 3 known one-port standards. To be used in a guided calibration, the known standards must be declared to be Open, Short, and Match irrespective of their properties.</p> <p>²⁾ Or any other known two-port standard. To be used in a guided calibration, the known standard must be declared to be Through, irrespective of its properties.</p>					



With a unidirectional R&S ZND (see [Chapter 5.1.4.3, "R&S ZND: Unidirectional vs. Bidirectional Operation"](#), on page 75) the "bidirectional calibrations" (TOSM and the following) are not available.



The calibration type must be selected in accordance with the test setup. Select the calibration type for which you can obtain or design the most accurate standards and for which you can measure the required parameters with best accuracy.

- [Normalization \(Refl Norm..., Trans Norm...\)](#)..... 143
- [Reflection OSM Calibration](#)..... 144
- [One Path Two Ports Calibration](#)..... 144
- [TOSM and UOSM Calibration](#)..... 145
- [Adapter Removal](#)..... 146
- [TOM Calibration](#)..... 147
- [TSM Calibration](#)..... 147
- [TRM Calibration](#)..... 148
- [TRL Calibration](#)..... 148
- [TNA Calibration](#)..... 150
- [Full n-Port Calibration with Reduced Number of Through Connections](#)..... 151
- [Complementary Isolation Measurement](#)..... 152

5.5.1.1 Normalization (Refl Norm..., Trans Norm...)

A normalization is the simplest calibration type since it requires the measurement of only one standard for each calibrated S-parameter:

- One-port (reflection) S-parameters (S_{11} , S_{22} , ...) are calibrated with an Open or a Short standard providing the reflection tracking error term.
- Two-port (transmission) S-parameters (S_{12} , S_{21} , ...) are calibrated with a Through standard providing the transmission tracking error term.

Normalization means that the measured S-parameter at each sweep point is divided by the corresponding S-parameter of the standard. A normalization eliminates the frequency-dependent attenuation and phase shift in the measurement path (reflection or transmission tracking error). It does not compensate for directivity or mismatch errors. This limits the accuracy of a normalization.



- Manual reflection normalizations offer [Complementary Match Standard Measurements](#)
- Manual transmission normalizations support [Complementary Isolation Measurement](#) (optional).

Complementary Match Standard Measurements

For reflection normalizations, the mandatory Open or Short measurements can be complemented by optional Match measurements. Additionally, measuring a Match standard allows you to eliminate errors due to the directivity of the internal couplers, which improves the accuracy of reflection measurements on well-matched DUTs (high return loss).



For reflection measurements on DUTs with low return loss, accuracy may be degraded compared to a simple reflection normalization.

5.5.1.2 Reflection OSM Calibration

A reflection OSM (full one-port) calibration requires a Short, an Open and a Match standard to be connected to a single test port. The three standard measurements are used to derive all three reflection error terms:

- The Short and Open standards are used to derive the source match and the reflection tracking error terms.
- The Match standard is used to derive the directivity error.

A reflection OSM calibration is more accurate than a normalization but is only applicable for reflection measurements.

5.5.1.3 One Path Two Ports Calibration

A one path two ports calibration combines a reflection OSM (full one-port) calibration with a transmission normalization. The fully calibrated port is termed the node port. This calibration type requires a Short, an Open and a Match standard to be connected to a single test port plus a Through standard between this calibrated source port and the other load ports. The four standard measurements are used to derive the following error terms:

- The Short and Open standards are used to derive the source match and the reflection tracking error terms at the source port.
- The Match standard is used to derive the directivity error at the source port.
- The Through standard provides the transmission tracking error terms.

For calibration of two ports, a one-path two-port calibration requires only four standards to be connected (instead of 7 for a full two-port TOSM calibration). It is suitable when only the forward (e.g. S_{11} and S_{21}) or reverse S-parameters (e.g. S_{22} and S_{12}) are needed, and if the DUT is well matched, especially at the load port.

A one-path two-port calibration is also the best calibration method for test setups with unidirectional signal flow.



With a unidirectional R&S ZND (see [Chapter 5.1.4.3, "R&S ZND: Unidirectional vs. Bidirectional Operation"](#), on page 75) only the forward direction (source port 1) is available.

5.5.1.4 TOSM and UOSM Calibration

TOSM

A TOSM (Through – Open – Short – Match) calibration requires the same standards as the one path two ports calibration, however, all measurements are performed in the forward and reverse direction. TOSM is also referred to as SOLT (Short – Open – Load = Match – Through) calibration. The four standards are used to derive 6 error terms for each signal direction:

- In addition to the source match and reflection tracking error terms provided by the one-path two-port calibration, TOSM also provides the load match.
- The directivity error is determined at all source ports.
- The transmission tracking is determined for each direction.

TOSM calibration is provided for 2-port measurements. A 2-port TOSM calibration requires 7 standard measurements (3 one-port standards at each port and a Through between the two ports). The Through must be measured in both directions, so the number of standard measurements (calibration sweeps) is 8. The calibration provides 10 error terms (no isolation terms are available).



With a unidirectional R&S ZND (see [Chapter 5.1.4.3, "R&S ZND: Unidirectional vs. Bidirectional Operation"](#), on page 75) both TOSM and UOSM calibration are unavailable.



Manual TOSM calibration supports [Complementary Isolation Measurement](#) (optional).

UOSM: TOSM with unknown Through

The analyzer can perform a TOSM calibration with any 2-port network serving as through connection, as long as it fulfills the reciprocity condition $S_{21} = S_{12}$. The modified TOSM calibration is referred to as UOSM (Unknown through – Open – Short – Match) calibration. It can be selected as follows:

- If different connector types are assigned to the test ports, the analyzer automatically replaces TOSM by UOSM.
[The network analyzer supports different connector types at its test ports to measure DUTs with different port connectors; see also [Chapter 5.5.1.5, "Adapter Removal"](#), on page 146.]
- If the same connector types are used but an appropriate Through standard is not defined, the analyzer also replaces TOSM by UOSM.
- UOSM can be selected explicitly in the "Calibration Setting" dialog.

After acquiring the calibration sweep data for the unknown through, the analyzer automatically determines its delay time/transmission phase.

5.5.1.5 Adapter Removal

Many DUTs use different connector types on their RF ports (e.g. port 1: N-type connector, female; port 2: PC 3.5-type connector, female).



DUTs of this sort are also known as **noninsertable devices**.

A suitable calibration kit is then required for each of the different connector types. The kit must include, as a minimum, the standards that are used for one-port calibration. The through-connection between test ports with different connector types must be made using **adapters**.

The problem here is that unlike Through standards, adapters are usually not characterized, i.e. their delay time/transmission phase is unknown.

If the adapter fulfills the reciprocity condition $S_{21} = S_{12}$, it can serve as **Unknown through** in an **UOSM** calibration (see "[UOSM: TOSM with unknown Through](#)" on page 145).

Adapter Removal is an extension of the **2-port UOSM** calibration. It requires two additional reflection OSM calibrations with the adapter successively connected to port 1 and port 2.

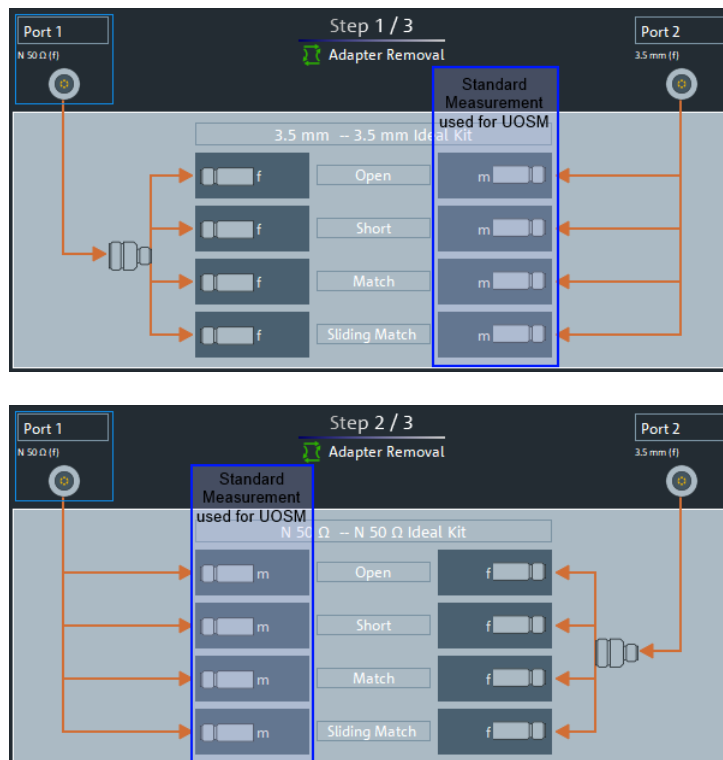

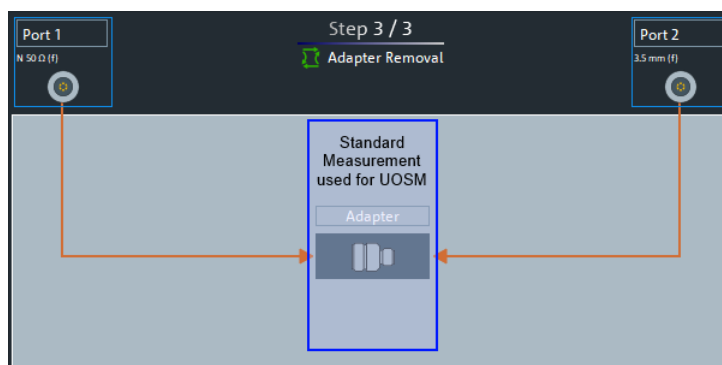

Figure 5-7: Adapter Removal vs. UOSM

The obtained adapter characteristics are mathematically removed from the obtained error coefficients. Uncertainties arising from a non-ideal characterization of the unknown through almost cancel, whereas they add up in the UOSM technique. As a consequence, Adapter Removal will provide more accurate results.



- With a unidirectional R&S ZND (see [Chapter 5.1.4.3, "R&S ZND: Unidirectional vs. Bidirectional Operation"](#), on page 75) Adapter Removal is not available.
- Currently Adapter Removal is not supported with [Automatic Calibration](#).

5.5.1.6 TOM Calibration

A TOM (Through – Open – Match) calibration requires a low-reflection, low-loss Through standard with an electrical length that can be different from zero, an Open, and a Match. The characteristics of all standards must be fully known; the Match can have non-ideal characteristics.



With a unidirectional R&S ZND (see [Chapter 5.1.4.3, "R&S ZND: Unidirectional vs. Bidirectional Operation"](#), on page 75) TOM calibration is not available.

5.5.1.7 TSM Calibration

A TSM (Through – Short – Match) calibration requires a low-reflection, low-loss Through standard with an electrical length that can be different from zero, a Short, and a Match. The characteristics of all standards must be fully known; the Match can have non-ideal characteristics.

TSM calibration can replace TOM calibration if no appropriate Open standard is available, especially in the high frequency domain.



With a unidirectional R&S ZND (see [Chapter 5.1.4.3, "R&S ZND: Unidirectional vs. Bidirectional Operation"](#), on page 75) TSM calibration is not available.

5.5.1.8 TRM Calibration

A TRM (Through – Reflect – Match) calibration requires a low-reflection, low-loss Through standard with an electrical length that can be different from zero, a Reflect, and a Match. The magnitude of the reflection coefficient of the Reflect standard can be unknown but must be nonzero; its phase must be roughly known (90 deg). The magnitude and phase of the reflection coefficient must be the same at both test ports.

TRM calibration is especially useful for DUTs in test fixtures.



With a unidirectional R&S ZND (see [Chapter 5.1.4.3, "R&S ZND: Unidirectional vs. Bidirectional Operation"](#), on page 75) TRM calibration is not available.

5.5.1.9 TRL Calibration

A TRL (Through – Reflect – Line) calibration requires the two-port standards Through and Line, which are both assumed to be ideally matched. Beyond that, the Through must be lossless, and its length must be exactly known. The length of the Line standard must be known approximately.

Furthermore, a reflecting one-port standard (Reflect) is needed. The magnitude of the reflection coefficient of the Reflect standard can be unknown but must be nonzero; its phase must be roughly known (90 deg). The magnitude and phase of the reflection coefficient must be the same at both test ports.

TRL calibration is especially useful for DUTs in planar line technology (e.g. test fixtures, on-wafer measurements) where it is difficult to design and connect accurately modeled Open, Short or Match standards. If TRL is not practicable, TNA may be an alternative.



With a unidirectional R&S ZND (see [Chapter 5.1.4.3, "R&S ZND: Unidirectional vs. Bidirectional Operation"](#), on page 75) TRL calibration is not available.

TRL with several lines and with TRM

The system of equations solved to derive the error terms is such that singularities occur whenever the length difference ΔL between the Through and the Line is an integer multiple of half of the wave length:

$$\Delta L \neq n \frac{\lambda}{2}$$

As a rule, singularities are avoided with sufficient accuracy if the phase shift resulting from the (electric) length difference between the Through and the Line standard is between 20° and 160°. This corresponds to a ratio of 1:8 for the start and stop frequency of the calibrated sweep range.



To shift the calibrated sweep range to smaller or larger frequencies, you can use a longer or shorter Line. To extend the calibrated range, use one of the following methods:

- Perform TRL calibration with two or three different Line standards. With an appropriate length of the Lines, the ratio for the start and stop frequency of the calibrated sweep range can increase to approx. 1:64 (for 2 lines) or 1:512 (for 3 lines).
- In the low-frequency domain where TRL becomes inaccurate, replace TRL by TRM calibration.

The methods can be combined or used separately. The list of measured standards in the calibration step for TRL calibration is extended if the calibration kit in use contains the necessary standards:

- A 2-line (3-line) calibration requires two (three) different Lines of matching gender. The lines must be measured between any combination of two ports.
- A TRM extension at low frequencies requires either a Match or a Sliding Match standard. The standard must be measured at each port.

The complete list of measured standards for a two-port calibration is shown below.

- For a **TRL calibration with 1 Line**, the Reflect standard at both ports, the Through, and one Line standard must be measured.
- For a **TRL calibration with 2 Lines**, a second Line standard must be measured in addition.
- For a TRM calibration, The Reflect and Match standards at both ports and the Through must be measured. See also [Chapter 5.5.2.3, "Sliding Match Standards"](#), on page 156.

The TRL calibration is valid when the standards for a TRL calibration with 1 line have been measured. The TRL extensions are applied automatically if the necessary standards have been measured.

P1	P2	P1 ↔ P2
N 50 Ω (f) N 50 Ω Ideal Kit	N 50 Ω (f) N 50 Ω Ideal Kit	N 50 Ω (f) N 50 Ω Ideal Kit
M Match (m)	M Match (m)	T Through (mm)
R Reflect (m)	R Reflect (m)	L Line 1 (mm)
Sliding M Pos 1	Sliding M Pos 1	L Line 2 (mm)
Sliding M Pos 2	Sliding M Pos 2	L Line 3 (mm)
Sliding M Pos 3	Sliding M Pos 3	

Example: TRL calibration with two and three Lines

If several Lines with different lengths are measured, the analyzer automatically divides the calibrated range into segments. The calibration data of the longest line is applied to the lowest segment, the calibration data of the shortest line to the highest segment.

The calibration sweep segments for two Lines with electric lengths l_{long} and l_{short} ($l_{\text{long}} > l_{\text{short}}$) are obtained as follows (the Through standard is assumed to be of length l_{thr}):

- The longer Line can be used up to a frequency f_{long} where its transmission phase is equal to 160 deg. This frequency is equal to

$$f_{\text{long}} = 4 * c_0 / [9 * (l_{\text{long}} - l_{\text{thr}})].$$

- The shorter Line can be used from a frequency f_{short} where its transmission phase is equal to 20 deg. This frequency is equal to

$$f_{\text{short}} = c_0 / [18 * (l_{\text{short}} - l_{\text{thr}})].$$
- The border between the two frequency segments f_{div} is calculated as the geometric mean of f_{long} and f_{short} , i.e.

$$f_{\text{div}} = \text{sqrt}(f_{\text{long}} * f_{\text{short}}).$$

The formulas are also applied if $f_{\text{long}} < f_{\text{short}}$.

For a TRL calibration using three Lines with different length, the allowed frequency ranges are calculated in an analogous manner to obtain three (ideally overlapping) frequency ranges. The borders between two adjacent frequency ranges are calculated as the geometric mean of the frequency limits f_{long} and f_{short} of the two ranges.



A second or third line in the list does not mean that you have to measure two or three line standards. If the calibrated frequency range is small enough, the calibration is valid when the analyzer has acquired correction data for a single Line standard. The Match and Sliding Match standards are not necessary for TRL calibration, however, they must be measured if TRL is combined with TRM calibration.

Low-frequency extension with TRM

TRL calibration becomes inaccurate if the electrical length difference between Line and Through standard corresponds to a phase shift below 20°. In practice this means that TRL is only practicable above a threshold frequency f_{TRM} which depends on the lengths of the longest line and through standards. The threshold frequency is given by:

$$f_{\text{TRM}} = c_0 / [18 * (l_{\text{long}} - l_{\text{thr}})]$$

where l_{long} denotes the electrical length of the longest of the used Line standards, l_{thr} the length of the Through. The analyzer assumes $l_{\text{thr}} \ll l_{\text{long}}$ and calculates $f_{\text{TRM}} = c_0 / (18 * l_{\text{long}})$. At frequencies below f_{TRM} , TRL calibration is automatically replaced by TRM, if the necessary calibration data has been acquired. For a line with $l_{\text{long}} = 16.666$ cm, the threshold frequency is $f_{\text{TRM}} = 100$ MHz.

Accuracy conditions for the Line(s)

The length error of the Line, converted into a transmission phase error, must be below the minimum difference to the singularity points 0 deg or 180 deg multiplied by two. Suppose that an approximately known Line standard causes a transmission phase 30 deg at the start frequency and of 160 deg at the stop frequency of the sweep. Its length error must cause a phase difference below $(180 \text{ deg} - 160 \text{ deg}) * 2 = 40 \text{ deg}$.

5.5.1.10 TNA Calibration

A TNA (Through – Network – Attenuation) calibration requires two-port standards only. Again, the Through standard must be ideally matched and lossless. The Symmetric Network must have the same properties as the Reflect standard used for a TRL calibration. I.e., the magnitude of its reflection coefficient can be unknown but must be

nonzero. Its phase must be roughly known (± 90 deg). The magnitude and phase of the reflection coefficient must be the same at both test ports. The Attenuation standard must be well matched on both sides and cause an attenuation different from 0 dB; the exact value of the transmission coefficient is not important.

As with TRL, TNA calibration is especially useful for planar DUTs. If TNA is not practicable, TRL can be an alternative.



With a unidirectional R&S ZND (see [Chapter 5.1.4.3, "R&S ZND: Unidirectional vs. Bidirectional Operation"](#), on page 75) TNA calibration is not available.

5.5.1.11 Full n-Port Calibration with Reduced Number of Through Connections

The analyzer can calculate the error terms for a full n-port calibration after $n-1$ Through measurements, if the measured Throughs connect all ports to be calibrated. The correction values for the unmeasured Throughs can then be calculated from the measured ones.

To establish a sufficient set of Through connections, you can select an arbitrary test port as the "center" and measure all Through connections to this test port ("star-shaped calibration"). You can also connect all ports in increasing order, e.g. $1 \rightarrow 2$, $2 \rightarrow 3$, $3 \rightarrow 4 \dots$

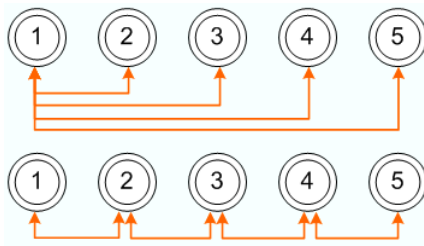

[For the mathematically inclined: the graph constructed from the calibration ports as nodes and the measured Throughs as edges must be connected.]



If an external switch matrix is configured and you want to calibrate three or more test ports that are all on the **same submatrix**, then an extra Through measurement is required: Complement the minimum set of $n-1$ Throughs (as explained above) by an additional Through at a port pair that is connected by a "chain of throughs" of length 2 (e.g. between ports 2 and 4 in the examples above).

See [Chapter 5.7.20, "External Switch Matrices"](#), on page 210 for background information on switch matrices and their submatrices.

Compared to the full number of $n(n-1)/2$ Through connections, the time and effort is significantly reduced, in particular if n is large.

The "Reduced Through" logic is implemented for all full n-port calibration types.

- During manual calibration, you can apply the calibration when a sufficient set of Through connections have been measured. However, you can measure additional Through connections to improve the accuracy.

- If **Multiple Port Assignments** are required, an **Automatic Calibration** always proposes a minimum number of port assignments. However, for each port assignment all possible through connections are measured by default. If you want to apply the "Reduced Through" logic also for each port assignment, you can activate it in the system configuration.

5.5.1.12 Complementary Isolation Measurement

For each port pair in a manual transmission normalization or TOSM calibration, the Through measurement can be complemented by an isolation measurement. This measurement accounts for possible crosstalk between the related test ports (e.g. on a test fixture).

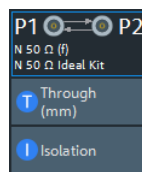

If isolation is measured, the corrected transmission coefficient of the DUT is calculated as:

$$\frac{(\text{Transmission coefficient DUT} - \text{Isolation})}{(\text{Transmission coefficient Through} - \text{Isolation})}$$

There is no dedicated physical standard for isolation measurement; it is recommended to terminate the test ports suitably (e.g. with 50 Ω loads).

5.5.2 Calibration Standards and Calibration Kits

A calibration kit is a set of physical calibration standards for a particular connector type. The magnitude and phase response of the calibration standards (i.e. their S-parameters) must be known or predictable within a given frequency range.

The standards are grouped into several types (Open, Through, Match,...) corresponding to the different input quantities for the analyzer's error models. The standard type also determines the equivalent circuit model used to describe its properties. The circuit model depends on several parameters that are stored in the cal kit file associated with the calibration kit.

As an alternative to using circuit models, it is possible to describe the standards with S-parameter tables stored in a file.

The analyzer provides many predefined cal kits but can also import cal kit files and create kits:

- A selection of predefined kits is available for all connector types. The parameters of these kits are displayed in the "View / Modify Cal Kit Standards" dialog, however, it is not possible to change or delete the kits.
- Imported and user-defined kits can be changed in the "Calibration Kits" dialog and its various subdialogs.

Calibration kits and connector types are global resources; the parameters are stored independently and are available irrespective of the current recall set.

5.5.2.1 Calibration Standard Types

The following table gives an overview of the different standards and their circuit models (offset and load models).

Table 5-8: Calibration standard types

Standard Type	Characteristics	Ideal Standard	Offset Model	Load Model
Open	Open circuit (one-port)	$\infty \Omega$	<input checked="" type="checkbox"/>	<input checked="" type="checkbox"/>
Short	Short circuit (one-port)	0Ω	<input checked="" type="checkbox"/>	<input checked="" type="checkbox"/>
Offset short	Short circuit with added electrical length offset, for waveguide calibration (one-port)	0Ω	<input checked="" type="checkbox"/>	<input checked="" type="checkbox"/>
Match	Matched broadband termination (one-port)	Z_0 (characteristic impedance of the connector type)	<input checked="" type="checkbox"/>	<input checked="" type="checkbox"/>
Sliding match	One-port standard consisting of an air line with a movable, low-reflection load element (sliding load)	–	–	–
Reflect	Unknown mismatched standard (one-port)	$\infty \Omega$	<input checked="" type="checkbox"/>	<input checked="" type="checkbox"/>
Through	Through-connection with minimum loss (two-port)	–	<input checked="" type="checkbox"/>	–
Line1, Line 2	Line(s) for TRL calibration with minimum loss (two-port)	–	<input checked="" type="checkbox"/>	–
Attenuation	Fully matched standard in both directions (two-port; the reflection factor at both ports is zero)	–	–	–
Symm. network	Unknown mismatched reflection-symmetric standard (two-port)	–	<input checked="" type="checkbox"/>	<input checked="" type="checkbox"/>

Offset parameters

The offset parameters have the following physical meaning:

- The *delay* is the propagation time of a wave traveling through the standard. The *electrical length* is equal to the delay times the speed of light in the vacuum. It is a measure for the length of transmission line between the standard and the actual calibration plane. For a waveguide with permittivity ϵ_r and mechanical length L_{mech} , the following relations hold:

$$\text{Delay} = \frac{L_{mech} \cdot \sqrt{\epsilon_r}}{c}; \quad \text{Electrical Length} = L_{mech} \cdot \sqrt{\epsilon_r}$$

The default delay is 0 s, the default step width is 1 ns, corresponding to a step width of 299.792 mm for the electrical length. The relations hold for one-port and 2-port standards.

- Z_0 is the characteristic impedance of the standard. If the standard is terminated with Z_0 , then its input impedance is also equal to Z_0 . Z_0 is not necessarily equal to the reference impedance of the system (depending on the connector type) or the

terminal impedance of the standard. The characteristic impedance of the standard is only used in the context of calibration.

The default characteristic impedance is equal to the reference impedance of the system.

- The *loss* is the energy loss along the transmission line due to the skin effect. For resistive lines and at RF frequencies, the loss is approximately proportional to the square root of the frequency.

In Keysight mode, the *offset loss* is expressed in units of Ω/s at a frequency of 1 GHz. The following formula holds for two-port standards:

$$\text{Offset Loss} / [\Omega / s] = \frac{\text{Loss} / [dB] \cdot Z_0 / [\Omega]}{4.3429 / [dB] \cdot \text{delay} / [s]}$$

The conversion formula for one-port standards has an additional factor $\frac{1}{2}$ on the right-hand side. The reason for this factor is that the Loss in dB accounts for the attenuation along the forward **and** the reverse path. It does not depend on how often the wave actually propagates through the line, whereas the offset loss is proportional to the attenuation of the line.

To determine an offset loss value experimentally, measure the delay in seconds and the loss in dB at 1 GHz and use the formula above.

The default loss or offset loss is zero.



The impedance for waveguides is frequency-dependent. If a waveguide line type is selected in the "Cal Connector Types" dialog, the "Char. Imp." field is disabled and indicates "varies" instead of a definite impedance value. Moreover no loss or offset loss can be set.

Offset parameters and standard types

Offset parameters are used to describe all types of standards except the Sliding Match and the Attenuation.

- The Sliding Match is a one-port standard with variable load parameters (sliding load) and unspecified length. The reference impedance is fixed and equal to the characteristic impedance of the connector type. No load and offset parameters need to be set.
- The Attenuation is a two-port standard which is fully matched in both directions (the reflection factor at both ports is zero). No load and offset parameters need to be set.

Load parameters and standard types

Load parameters are used to describe all types of standards except a Through, a Sliding Match, a Line, and an Attenuation.

- The Through standard is a through-connection between two ports with minimum loss which is taken into account by the offset parameters.
- The Sliding Match is a one-port standard with variable load parameters (sliding load), so there is no fixed load model.
- The Line standard is a line of variable length with minimum loss which is taken into account by the offset parameters.

- The Attenuation is a two-port standard which is fully matched in both directions (the reflection factor at both ports is zero). No load and offset parameters need to be set.

5.5.2.2 Cal Kit Parameter Types

Available Cal Kits	
	Kit Name
1	N 50 Ω Ideal Kit
2	3653
3	85054D
4	ZV-Z121
5	ZV-Z170
6	ZCAN 50 Ω
7	ZV-Z21 typical
8	85032 R/F

The analyzer uses three types of parameters to describe the calibration standards. The parameter type is the same for all standards in a kit and therefore appended to the kit name:

- **Universal** parameters (no suffix) describe calibration kit models with highly standardized components so that the parameters are valid for all calibration kits of the model.
- **Typical** parameters (suffix "typical") approximately describe a calibration kit model. To correct for deviations between the standards, each kit of the model is individually measured and delivered with an additional, kit-specific parameter set. Therefore each typical parameter set "<kit_name> typical" is complemented by an additional parameter set "<kit_name>" containing optimized parameters for an individual kit.
- **Ideal** parameters (suffix "Ideal Kit") describe an idealized calibration kit for each connector type; see below.



Make sure to use universal or individual parameter sets if you need to obtain high-precision results. The precision of the calibration kit parameters determines the accuracy of the system error correction and of the measurements. The R&S ZND displays a warning if you use a typical or ideal parameter set to calibrate a channel.

Calibration kits can be obtained as network analyzer accessories; refer to the data sheet for the relevant ordering information. The name of all parameter sets is equal to the name of the corresponding calibration kit model.

Ideal parameters

All ideal kits contain the standards listed below.

Table 5-9: Ideal standard parameters

Standard (Gender)	R (Load)	Electrical Length (Offset)
Open (f, m)	$\infty \Omega$	0 mm (Delay: 0 s)
Short (f, m)	0Ω	0 mm
Offset Short (f, m)	0Ω	10 mm
Match (f, m)	Z_0 (characteristic impedance of the connector type)	0 mm
Sliding Match (f, m)	–	0 mm
Reflect (f, m)	$\infty \Omega$	0 mm
Through (ff, mm, mf)	–	0 mm
Line (ff, mm, mf)	–	10 mm

Standard (Gender)	R (Load)	Electrical Length (Offset)
Attenuation (ff, mm , mf)	–	0 mm
Symm. Network (ff, mm, mf)	–	0 mm

The following additional parameters are used:

- Characteristic impedance: Z_0 (characteristic impedance of the connector type)
- Loss: 0 dB / sqrt(GHz) or (0 G Ω / s) in Keysight mode
- All inductance and capacitance parameters are set to zero.

5.5.2.3 Sliding Match Standards

The Sliding Match is a one-port standard consisting of an air line with a movable, low-reflection load element (sliding load). This standard is used because a no perfect Match is available over a wide frequency range. However, a series of measurements at a given frequency with equal mismatch and varying phase yields reflection factors that are located on a circle in the Smith chart. The center of this circle corresponds to perfect match. The network analyzer determines and further corrects this match point following I. Kása's circle-fitting algorithm.

To obtain the reflection coefficient for a perfectly matched calibration standard, the Sliding Match must be measured at least at 3 positions which should be unequally spaced to avoid overlapping data points. Increasing the number of positions to 4 to 6 can improve the accuracy. Moreover, using the predefined load positions of the standard is recommended.

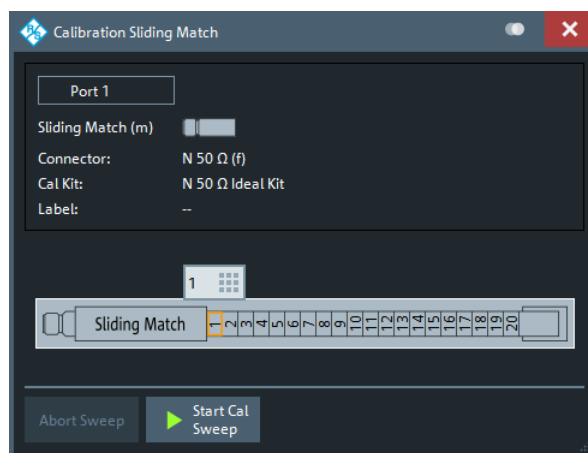

Figure 5-8: Sliding Match: GUI representation

A calibration is valid (and can be applied to the calibrated channel) if either the Match or three positions of the Sliding Match have been measured. However, it is often desirable to acquire calibration data from both standards.



The R&S ZND can acquire correction data for up to 20 positions.

The analyzer combines the data in an appropriate manner:

- The Match results are used up to the lower edge of the specified frequency range of the Sliding Match (Min Freq).
- The Sliding Match results are used for frequencies above the Min Freq. In general, the Sliding Match provides better results than the Match within its specified frequency range.

5.5.2.4 Cal Kit Files

Calibration kit files can be used to store the parameters of a particular calibration kit, to reload the data and to exchange calibration kits from one network analyzer to another.

Cal kit file contents

Cal kit files are independent of the current recall set and contain the following information:

- Name and label of the calibration kit
- Connector type including all connector type parameters (name, polarity, offset model, reference impedance)
- Type, gender and label of all standards in the kit together with the circuit model parameters (offsets, load) or S-parameter tables (.s<n>p file) that are necessary to determine its magnitude and phase response.

By default cal kit files are stored in the

C:\Users\Public\Documents\Rohde-Schwarz\Vna\Calibration directory.

- To **export** cal kit data, the analyzer uses a specific binary file format *.calkit.
- Three different **import** file formats are supported: R&S ZVA-specific binary cal kit files (*.calkit), R&S ZVR-specific binary cal kit files (*.ck), cal kit files in Keysight-specific ASCII formats (*.csv, *.prn).



Importing older R&S ZVR cal kit files

On loading some older R&S ZVR-specific *.ck files, e.g. the R&S ZV-Z23 cal kit file, the R&S ZND generates the message "File does not comply with instrument calibration kit file format". The files must be converted using an R&S ZVR network analyzer equipped with a firmware version V3.52 or later.

Proceed as follows:

- On the R&S ZVR, press "CAL > CAL KITS > MODIFY KITS > INSTALL NEW KIT" to import the *.ck file.
- Press "CREATE INST FILE" in the same submenu to export the *.ck file in a R&S ZND-compatible format.
- Import the converted file into the R&S ZND.

*.csv cal kit files: VNA Cal Kit Manager V2.1

The VNA Cal Kit Manager is a free, Windows®-based software tool intended to import, edit, and export *.csv cal kit files. The software is available for download at <http://>

na.support.keysight.com/vnahelp/products.html. The decimal separator used by the VNA Cal Kit Manager V2.1 depends on the language version of the Windows® operating system: Cal kit files generated on an English operating system contain dots, the ones generated on a German system contain commas.

The network analyzer expects the dot as a separator and displays an error message when a *.csv file with commas is loaded. Please install the VNA Cal Kit Manager V2.1 on an appropriate (e.g. English) Windows® version to avoid trouble.

***.prn cal kit files: PNA Cal Kit Editor**

The network analyzer can import and process cal kit files created with the PNA Cal Kit Editor. The files use the extension *.prn; the data format is identical to the *.csv format. The software is available for download at <http://na.support.keysight.com/pna/apps/#calkiteditor>.

The decimal separator used by the PNA Cal Kit Editor depends on the language version of the Windows® operating system: Cal kit files generated on an English operating system contain dots, the ones generated on a German system contain commas.

The network analyzer expects the dot as a separator and displays an error message when a *.prn file with commas is loaded. Please install the PNA Cal Kit Editor on an appropriate (e.g. English) Windows® version to avoid trouble.

5.5.3 Calibration Pool

The calibration "Pool" is a collection of correction data sets (cal groups) that the analyzer stores in a common directory

C:\Users\Public\Documents\Rohde-Schwarz\Vna\Calibration\Data. Cal groups in the pool can be applied to different channels and recall sets. Each cal group is stored in a separate file named <CalGroup_name>.cal. The cal group name can be changed in the "Calibration Manager" dialog.

One of the available cal groups can be set as "Preset User Cal", i.e. the user correction data that should be restored after a user-defined preset.

If a new channel is created, the channel calibration of the active channel is also applied to the new channel. See also [Calibration Labels](#).

5.5.4 Calibration Labels

The following labels in the trace list inform you about the status or type of the current system error correction.

Table 5-10: Calibration labels (system error correction)

Label	Meaning
Cal	The system error correction is applied without interpolation. This means that a set of measured correction data is available at each sweep point.
Cal int	The system error correction is applied, however, the correction data for at least one sweep point is interpolated from the measured values. This means that the channel settings have been changed so that a current sweep point is different from the calibrated sweep points. It is not possible to disable interpolation.
Cal Off	The system error correction is no longer applied (e.g. "User Cal Active" is disabled). See also "Cal Off label" on page 141.

5.5.5 Automatic Calibration

A calibration unit is an integrated solution for automatic system error correction of vector network analyzers. Rohde & Schwarz offers a wide range of calibration units for different frequency ranges and connector types. The connector types of the calibration unit should be selected according to the connector types of the DUT.

The calibration units contain calibration standards that are electronically switched when a calibration is performed. The calibration kit data for the internal standards is also stored in the calibration unit, so that the analyzer can calculate the error terms and apply the calibration without any further input.



Advantages of automatic calibration

Automatic calibration is faster and more secure than manual calibration, because:

- There is no need to connect several standards manually. The number of connections to be performed quickly increases with the number of ports.

- Invalid calibrations due to operator errors (e.g. wrong standards or improper connections) are almost excluded.
- No need to handle calibration kit data.
- The internal standards do not wear out because they are switched electronically.

Limitations of automatic calibration

Calibration units do not contain characterized Through standards, so calibration types TOM, TSM, TRM, TRL, TNA are not available.

NOTICE

Safety instructions

Please observe the safety instructions provided with the calibration unit to avoid any damage to the unit and the network analyzer. Safety-related aspects of the connection and operation of the units are also reported in the following sections.

5.5.5.1 Connecting the Calibration Unit

The calibration units provide the following connectors:

- USB type B connector at the rear, which is used to power-supply and control the unit. A USB cable for connection to the network analyzer is provided with the calibration unit.
- RF connectors, which are connected to the test ports. For all Rohde & Schwarz calibration units except a customized R&S ZN-Z51, the connector types are equal for all ports.

To connect the unit,

1. Switch on and power up your network analyzer.
2. To protect your equipment against ESD damage, use the wrist strap and grounding cord supplied with the instrument and connect yourself to the GND connector at the front panel.
3. Connect the USB type A connector of the USB cable to any of the USB type A connectors of the analyzer. Connect the USB type B connector of the USB cable to the USB type B connector of the calibration unit.
4. Wait until the operating system has recognized and initialized the new hardware. When the unit is connected for the first time, this may take longer than in normal use.

The unit is ready to be used, see [Chapter 5.5.5.2, "Performing an Automatic Calibration"](#), on page 161.



Safety aspects

- The calibration unit is intended for direct connection to R&S ZND network analyzers following the procedure described above. You can also connect the unit before switching on the analyzer. Do not connect the unit to other USB hosts, e.g. a PC, or insert any USB hubs between the analyzer and the unit, as this may damage the unit or the host.
- You can connect several calibration units to the different USB ports of the analyzer. You can also connect cal units and other devices (mouse, USB memory stick etc.) simultaneously.
- An unused calibration unit may remain connected to the USB port while the network analyzer is performing measurements. It must be disconnected during a firmware update.
- It is safe to connect or disconnect the calibration unit while the network analyzer is operating. Never connect or disconnect the unit while data is being transferred between the analyzer and the unit. Never connect the unit during a firmware update.

5.5.5.2 Performing an Automatic Calibration

After connection and initialization of the calibration unit, perform the automatic calibration of the related test ports using the "Calibration Unit" wizard (CHANNEL – [CAL] > "Start Cal" > "Start... (Cal Unit)"; see [Chapter 6.11.1.3, "Calibration Unit Wizard"](#), on page 376). The wizard indicates the required port (re-)connections.



The assignment between the analyzer ports and the cal unit ports can be detected automatically. If auto-detection fails (e.g. because of a high attenuation in the signal path), you can either enter the port assignment manually or connect matching port numbers and select "Default Port Assignment".

When finished, remove the test cables from the unit, connect your DUT instead and perform calibrated measurements.



Accuracy considerations

To ensure an accurate calibration, please observe the following items:

- Unused ports of the calibration unit must be terminated with a 50 Ω match.
- No adapters must be inserted between the calibration unit and the test ports of the analyzer.
- Allow for a sufficient warm-up time before starting the calibration. Refer to the specifications of the calibration unit for details.
- To ensure best accuracy, the analyzer automatically reduces the source power to -10 dBm. If the test setup contains a large attenuation, deactivate "Auto Power Setting for Cal Unit" in the "Calibration" tab of the "System Config" dialog. Ensure an input power of -10 dBm at the ports of the calibration unit (please also refer to the specifications of the calibration unit).

NOTICE**Maximum RF input power**

The maximum RF input power of the calibration unit is beyond the RF output power range of the analyzer, so there is no risk of damage if the device is directly connected to the test ports. If you use an external power amplifier, make sure that the maximum RF input power of the calibration unit quoted in the data sheet is never exceeded.

The available calibration types depend on the number of ports to be calibrated. For a single calibrated port, the reflection calibration types are available ("Refl Norm Open", "Refl Norm Short", "Refl OSM").

If 2 ports should be calibrated, the analyzer provides the following additional calibration types:

- A single full 2-port (TOSM or UOSM) calibration.
A single full 2-port (TOSM or UOSM) calibration.
- Two full one-port calibrations for the two calibrated ports.
- A one path two port calibration. The node port is the source port for the one path two port calibration (fully calibrated port).
- A transmission normalization (bidirectional, forward or reverse). "Forward" transmission normalization means that the signal direction is from port 1 to port 2.

5.5.5.3 Characterization of Calibration Units

Each calibration unit is delivered with factory characterization data which ensure an accurate calibration for all standard applications. For specific modifications of the test setup, e.g. the connection of additional adapters to a calibration unit, a modified set of characterization data (suitable for the cal unit with adapters) may be desirable. The R&S ZND provides a characterization wizard which you can use to generate your own characterization data sets for (modified) R&S cal units. The characterization data can be stored in the cal unit and used for automatic calibration whenever needed.

A cal unit characterization can be performed in a frequency sweep. The network analyzer must be properly calibrated, with the reference plane at the input ports of the (modified) cal unit to be characterized.

The procedure involves the following steps:

1. Perform a calibration of your network analyzer, using the test setup and the calibration type you wish to perform with your calibration unit.
2. Connect the calibration unit to the network analyzer.
3. Access the "Characterize Cal Unit" dialog (CHANNEL – [CAL] > "Cal Devices" > "Characterize Cal Unit...") and select "Start Characterization...".
4. Step through the "Characterization" wizard, following the instructions in the dialogs.

Dependency between calibration types and characterization data

A cal unit characterization provides full one-port (OSM) data at the selected ports plus two-port (Through) data between any pair of selected ports. The measurement of Through data is optional, however, it is required for some calibration types. The following table gives an overview.

Calibration type	Characterization data required
Refl Norm Open Refl Norm Short Refl OSM UOSM TOSM	OSM CalPort 1, OSM CalPort2 ... (all calibrated ports)
Trans Norm Both Trans Norm Forward One Path Two Ports	OSM CalPort 1, OSM CalPort2 ... (all calibrated ports), Through (between all pairs of ports)

5.5.5.4 Calibration Validation

This feature allows you to validate the active channel calibration against the expected result from a stored characterization. It requires an R&S calibration unit.



Cal validation works with at most 4 calibrated ports and with 2- and 4-port calibration units.

Calibration validation provides an automated, single-click (basic) mode, and an advanced mode for detailed validation and adjustment of limit tolerances, reporting, and SCPI automation.

Basic mode

When "Cal Validation" is launched for the first time, it runs in basic mode. In this mode, the R&S ZND automatically detects the instrument ports connected to the cal unit, and only validates connected ports. Thus, if a 2-port cal unit is connected to a 4-port calibrated channel, only the two connected instrument ports are validated against the cal unit.



The validation logic proceeds through the connected ports $p \in \{1, \dots, 4\}$ in ascending order, measuring S_{pp} for the Open, Short and Match standard. It then compares the measured S_{pp} values with the corresponding reflection S parameters of the cal unit's factory characterization. The on-screen feedback indicates success ("PASS", failure ("FAIL") or provides a warning about undetected ports.



For a channel with more calibrated ports than cal unit ports available, you can change the port assignments and rerun the automated validation. Or you can switch to advanced mode and validate each port manually.

Advanced mode

In advanced mode you can configure the validation settings (reference characterization, deviation limits) and run or rerun particular measurements (reflection at port p with connected Open, Short or Match).



5.5.5.5 Multiple Port Assignments

With multiple port assignments, it is possible to calibrate several test ports that exceeds the number of ports of the calibration unit or cal unit characterization in use. E.g. you can use a 2-port calibration unit to perform a full 4-port calibration.



The multiple port assignment method considerably extends the range of applications of the calibration units. However, the method entails some loss of convenience because you have to reconnect the calibration unit between the different calibration stages (assignments). It can also cause a loss of accuracy because only a subset of all possible through connections is measured.

To calibrate n test ports with an m -port calibration unit ($m < n$), the calibration unit has to be reconnected at least n/m times. Each of these (re-)connections is described by its "port assignment", i.e. the mapping of calibration unit ports to test ports. Then for each assignment an automatic calibration is performed. Finally the analyzer combines the calibration data and calculates the required n -port error terms.

This is possible if and only if:

- the port assignments "cover" the calibrated test ports
- the overlap between assignments allows a(n ordered) "chain of measured through connections" between any (ordered) pair of test ports requiring a Through measurement

For Full n -Port calibrations, the R&S ZND applies the "reduced through" logic to calculate the correction terms for those test port pairs that are not covered by a single assignment and hence cannot be measured directly (see [Chapter 5.5.1.11, "Full \$n\$ -Port Calibration with Reduced Number of Through Connections"](#), on page 151). Depending on the calibration type, a "minimal" valid and complete solution can be described as follows:

Calibration type	Minimal solution	Default solution (minimal)
Full One Port	Each calibrated test port must appear in exactly one port assignment.	Subdivide the n test ports into groups of m ports with increasing port numbers. Create a separate port assignment for each group.
One Path Two Port	<ul style="list-style-type: none"> The node port must be included in all port assignments Each of the n-1 other calibrated test ports must appear in exactly one port assignment <p><i>Additional condition:</i> The calibration unit port assigned to the node port must be the same in all assignments. This minimizes the number of port reconnections between the calibration stages.</p>	Assign the node port to port 1 of the calibration unit. Subdivide the remaining n-1 test ports into groups of m-1 ports. Create a separate port assignment for each group. Leave port 1 of the calibration unit connected to the node port and connect the ports of each of the port groups to the remaining m-1 ports of the calibration unit.
Full n-Port	<ul style="list-style-type: none"> the two generic conditions stated above (with "unordered Throughs") the number of assignments must be as small as possible <p><i>Additional condition:</i> The cal unit port assigned to a given test port must be the same in all assignments. Again, this minimizes the number of port reconnections between the calibration stages.</p>	Same as for One Path Two Port calibrations, using the test port with the lowest number as "node port". (Every other calibrated port could serve as "node port")

Among the minimal ones, the "star-shaped" solutions with fixed (but arbitrary) "node port" are also optimal w.r.t. the (average) length of the "Chain of Throughs" and hence the accuracy of the calculated Throughs. Additional port assignments can improve the accuracy, if they add more measured through connections.



For full n-port calibrations, an extra assignment is required if:

- an External Switch Matrix is used
- 3 or more test ports shall be calibrated, all of them located on the **same submatrix**
- only 2 Cal Unit ports are available

Starting with the minimal solution (as explained above), create an additional 2-port assignment for a pair of ports that was previously not covered by a single, but by two assignments.

See [Chapter 5.7.20, "External Switch Matrices"](#), on page 210 for background information on switch matrices and their submatrices.

Example:

The following examples show minimal port assignments for a Full 9-Port calibration using a four-port calibration unit:

Table 5-11: Full n-port: Star-shaped optimum solution

Test Port	Assignment 1	Assignment 2	Assignment 3
1	Cal Unit Port 1	Cal Unit Port 1	Cal Unit Port 1
2	Cal Unit Port 2	-	-

Test Port	Assignment 1	Assignment 2	Assignment 3
3	Cal Unit Port 3	-	-
4	Cal Unit Port 4	-	-
5	-	Cal Unit Port 2	-
6	-	Cal Unit Port 3	-
7	-	Cal Unit Port 4	-
8	-	-	Cal Unit Port 2
9	-	-	Cal Unit Port 3

Table 5-12: Full n-port: Line-shaped optimum solution

Test Port	Assignment 1	Assignment 2	Assignment 3
1	Cal Unit Port 1	-	-
2	Cal Unit Port 2	-	-
3	Cal Unit Port 3	-	-
4	Cal Unit Port 4	Cal Unit Port 4	-
5	-	Cal Unit Port 1	-
6	-	Cal Unit Port 2	-
7	-	Cal Unit Port 3	Cal Unit Port 3
8	-	-	Cal Unit Port 1
9	-	-	Cal Unit Port 2

5.5.6 Scalar Power Calibration

The purpose of a scalar power calibration is to ensure accurate source power levels and power readings at a particular position (calibration plane) in the test setup. Scalar power calibration is different from the system error correction described in [Chapter 5.5, "Calibration"](#), on page 140.

A power calibration is required for accurate measurement of wave quantities or ratios (see section [Chapter 5.1.5, "Data Flow"](#), on page 77). For best accuracy, choose a calibration method according to the table below.

Table 5-13: System error correction and power calibration for various measurements

Measurement	System error correction	Scalar power calibration
S-parameter meas. on linear DUTs	Yes, necessary	Not necessary
Meas. of wave quantities or ratios on linear or non-linear DUTs	Yes, recommended	a-wave: power (source) necessary b-wave: meas. receiver necessary
Power sweep, e.g. for compression point measurement	Yes, necessary	Power (source): necessary Meas. receiver: not necessary

In general, a power calibration involves two stages:

1. **Source power calibration:** An external power meter is connected to the calibration plane. The analyzer uses the power meter readings to calibrate its reference receiver. Subsequently, it modifies its source power so that the calibrated reference receiver reading corresponds to the desired source power value (flatness calibration).

Tip: Since version 3.0 of the analyzer firmware, it is possible to perform the source (flatness) calibration using the power meter (without previously calibrating the reference receiver).

2. **Measurement receiver calibration:** The analyzer uses the calibrated source signal to adjust the power reading at the receive port.

5.5.6.1 Source Power Calibration

A source power calibration ensures accurate power levels of the generated waves at an arbitrary calibration plane in the measurement path. Typically the calibration plane corresponds to the input of the DUT.

In a frequency sweep, the power at the calibration plane is maintained at a constant "Cal Power" value. The source power calibration eliminates frequency response errors in the signal path between the source and the calibration plane. It is possible to introduce an arbitrary attenuation or gain into the signal path so that the cal power is not restricted to the power range of the source. A typical application for a power calibration in a frequency sweep is the measurement of the gain of an amplifier across a frequency range but at a fixed input power.

In a power sweep, the power calibration ensures that the power at the calibration plane is either constant or a linear function of the stimulus power. A typical application for a power calibration in a power sweep is the measurement of the gain of an amplifier across a power range but at a fixed frequency. The correction data acquired in a frequency or power sweep is re-used if a "Time" or "CW Mode" sweep is activated.

Calibration procedure

The source power calibration requires an external power meter, to be connected via GPIB bus, USB or LAN interface. The power sensor can be connected directly at the calibration plane or to any other point in the test setup where the signal power is known to be proportional to the power at the calibration plane.

By default, the source power calibration involves several steps:

1. **Reference receiver calibration:** The analyzer performs a first calibration sweep at the source power that is likely to produce the target power ("Cal Power") at the calibration plane. A known attenuation or gain at the source port and in the signal path between the source port and the calibration plane can be specified:

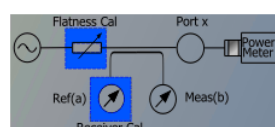

The power which the external power meter measured at the calibration plane is displayed in the calibration sweep diagram, together with the reference receiver reading. The firmware uses the difference between the two traces to correct the reference receiver reading.

2. **Internal source power flatness calibration:** In the following steps, the calibrated reference receiver is used to adjust the source power. To this end, the R&S ZND performs a series of calibration sweeps at varying source power until the number of "Total Readings" is reached or until the deviation between the calibrated reference receiver power and the cal power is below a specified "Tolerance". The external power meter is no longer used for these repeated calibration sweeps; everything is based on the previously calibrated reference receiver. This speeds up the calibration procedure but does not impair its accuracy.

Tip: Since version 3.0 of the analyzer firmware, it is also possible to perform the source (flatness) calibration using a power meter (without previously calibrating the reference receiver).

3. After the flatness calibration, the R&S ZND performs an additional verification sweep to demonstrate the accuracy of the calibration.

After the source power calibration, one can expect the power at the calibration plane to be within the range of uncertainty of the power meter. The reference receiver reading corresponds to the calibrated source power. After a change of the sweep points or sweep range, the analyzer interpolates or extrapolates the calibration data; see [Chapter 5.5.6.3, "Power Calibration Labels"](#), on page 170.

5.5.6.2 Measurement Receiver Calibration

A measurement receiver calibration ensures that the power readings at a specified receive port of the analyzer (b-waves) agree with the source power level calibrated at an arbitrary calibration plane. Typically, the calibration plane is at the input of the receiver so that the calibration eliminates frequency response errors in the calibrated receiver.

In contrast, the reference receiver calibration ensures correct power readings for the generated waves (a-waves).

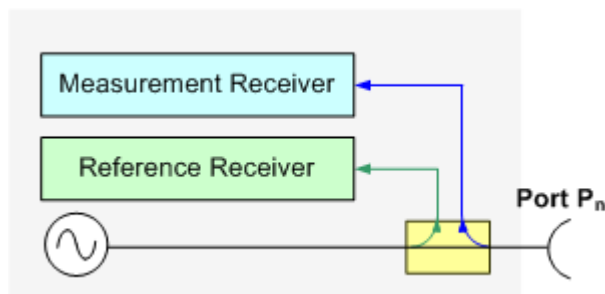

A measurement receiver calibration generally improves the accuracy of power (wave quantity) measurements. The correction data acquired in a frequency or power sweep is re-used if a "Time" or "CW Mode" sweep is activated.

Calibration procedure

The measurement receiver calibration is based on a received wave b_n with known power. The calibration involves a connection to a (previously source power-calibrated) source port.

The received wave to calibrate is generated by the other analyzer port P_m ($m \neq n$). Alternatively, it is possible to connect an Open or Short standard to port P_n : The measurement receiver is calibrated using the reflected wave a_n .

The measurement receiver calibration involves a single calibration sweep. The calibration sweep is performed with current channel settings but with a maximum IF bandwidth of 10 kHz. Smaller IF bandwidths are maintained during the calibration sweep; larger bandwidths are restored after the sweep. The analyzer measures the power at each sweep point, compares the result with the nominal power of the source, and compiles a correction table.

An acoustic signal indicates the end of the calibration sweep. At the same time, a checkmark symbol next to the calibrated source indicates the status of the measurement receiver calibration. After a change of the sweep points or sweep range, the analyzer interpolates or extrapolates the calibration data.

5.5.6.3 Power Calibration Labels

Power calibration labels in the trace list for wave quantities and ratios inform you about the status and type of the current scalar power calibration. The labels appear in the following instances:

- For a-waves, if a source power calibration is available.
- For b-waves, if a measurement receiver power calibration is available.
- For ratios between a- and b-waves, if both a source power and a measurement receiver power calibration is available.



Calibration of S-parameters

S-parameters and derived quantities (e.g. impedances, admittances, stability factors) are assumed to be linear.

Therefore, a scalar power calibration is not applied to S-parameters and derived quantities; no power calibration labels appear in the trace list.

Table 5-14: Power calibration labels

Label	Meaning
PCal	A scalar power calibration is available and applied without interpolation or extrapolation (see below). This means that a set of measured correction data is available at each sweep point.
PCai	The power calibration is applied, however, the correction data for at least one sweep point is interpolated from the measured values. This means that the channel settings have been changed so that a current sweep point is different from the calibrated sweep points. It is not possible to disable interpolation.

Label	Meaning
PCao	The power calibration is applied, however, the source power (channel base power) was out of tolerance.
PCax	The power calibration is applied, however the calibration data is extrapolated. The current stimulus range exceeds the calibrated stimulus range. The power calibration data of the first calibrated sweep point is used for all smaller stimulus values; the power calibration data of the last calibrated sweep point is used for all larger stimulus values.
PCa< j o x> S	Like PCa< j o x>, but only a source flatness calibration is available
PCa< j o x> R	Like PCa< j o x>, but only a receiver calibration is available
PCal Off	The power calibration is no longer applied (e.g. deliberately turned off in the "Calibration > Use Cal " softtool panel).

A lower label in the list has priority over the higher labels (e.g. if the power calibration is interpolated and the source power is changed, then the label PCao is displayed).

Interpolation and extrapolation

The analyzer can interpolate and extrapolate power correction data so that a source or receiver power calibration can be reused after a change of the frequency sweep range:

- At new sweep points within the calibrated sweep range, interpolation is applied to calculate the correction data. A label "PCai" in the trace list indicates an interpolated power calibration.
- At new sweep points outside the calibrated sweep range, the correction values are extrapolated: Sweep points below the lowest calibrated frequency are assigned the correction value of the lowest frequency. Sweep points above the highest calibrated frequency are assigned the correction value of the highest frequency. A label "PCax" in the trace list indicates an extrapolated power calibration.

5.5.6.4 Extended Test Setups

The power calibration data can be modified to account for an additional two-port device in the test setup. The known transmission coefficients of the two-port can be entered manually or automatically (CHANNEL – [CAL] > "Pwr Cal Settings" > "Transm. Coefficients..."). The R&S ZND supports two different test scenarios.

A: Two-port at DUT (during measurement)

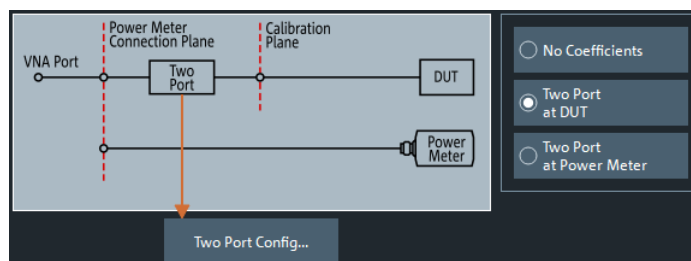

Test and measurement procedure:

1. Perform the calibration without the additional two-port. During the calibration, the analyzer decreases the power sensor values by the 2-port transmission coefficients to move the calibration plane of the power calibration towards the input of the DUT. The calibration plane corresponds to the output of the 2-port which is placed in-between the network analyzer port and the DUT.
2. Perform the measurement with the additional two-port.

Practical example: On-wafer measurements. The power sensor cannot be directly connected to the input of the DUT. The transmission coefficients of the wafer probe are used for the power meter correction.

B: Two-port at power meter (during calibration)

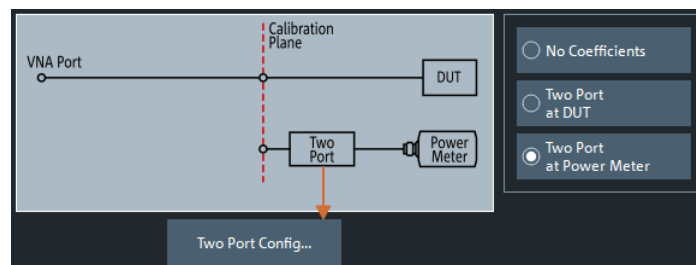

Test and measurement procedure:

1. Perform the calibration with the additional two-port between the analyzer port and the power sensor. During the calibration, the analyzer increases the power sensor values by the 2-port transmission coefficients to move the calibration plane of the power calibration towards the input of the DUT. The calibration plane corresponds to the input of the additional 2-port.
2. Perform the measurement without the additional two-port.

Practical example: An adapter or attenuator with known attenuation is needed to connect the power sensor to the test port of the network analyzer. The transmission coefficients of the adapter are used for the power meter correction.

5.5.7 Parallel Calibration of Multiple Channels

If multiple channels are configured in the active recall set, clearly they can be calibrated one after the other, but this can be inefficient in terms of necessary reconnections of calibration standards (or calibration units).

The R&S ZND offers multiple possibilities to calibrate several channels in parallel:

- Calibrate multiple channels in one go, using the same calibration type on the same ports for all channels
In this case, for each port to be calibrated the same calibration standards have to be connected. After connecting one of these standards, a calibration sweep has to be performed for each channel.

This simple mode of parallel calibration is supported from the analyzer GUI ("Calibrate all Channels" checkbox in all calibration wizards) and via remote control (see [\[SENSe:\]CORRection:COLLect:CHANnels:ALL](#) on page 914).

- Calibrate a subset of the available channels, possibly using different ports and calibration types, using **remote control**.
In this case, for each port to be calibrated a different set of calibration standards might be required. For each of these standards only a subset of the available channels might have to be swept. See [\[SENSe:\]CORRection:COLLect:CHANnels:MCTypes](#) on page 915.
This advanced mode of parallel calibration is available via **remote control only**.

5.6 Offset Parameters and De-/Embedding

The R&S ZND functionality described in this section complements the calibration, compensating for the effect of known transmission lines or matching networks between the calibrated reference plane and the DUT.

5.6.1 Offset Parameters

Offset parameters compensate for the known length and loss of a (non-dispersive and perfectly matched) transmission line between the calibrated reference plane and the DUT.

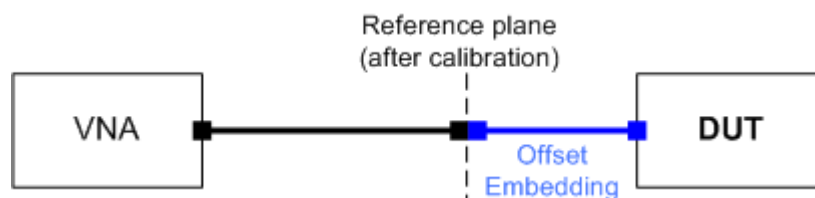

The analyzer can also auto-determine length and loss parameters, assuming that the actual values should minimize the group delay and loss across a configurable frequency range.

5.6.1.1 Definition of Offset Parameters

The *delay* is the propagation time of a wave traveling through the transmission line. The *electrical length* is equal to the delay times the speed of light in the vacuum. It is a measure for the length of the transmission line between the standard and the actual calibration plane. For a line with permittivity ϵ_r and *mechanical length* L_{mech} the delay and the electrical length are calculated as follows:

$$Delay = \frac{L_{mech} \cdot \sqrt{\epsilon_r}}{c}; \quad Electrical\ Length = L_{mech} \cdot \sqrt{\epsilon_r}$$

In the CHANNEL – [OFFSET EMBED] > "Offset" softtool tab, "Delay", "Electrical Length" and "Mech. Length" are coupled parameters. When one of them is changed, the other two are adjusted accordingly.

For a non-dispersive DUT, the delay defined above is constant over the considered frequency range and equal to the negative derivative of the phase response for the frequency (see mathematical relations). The length offset parameters compensate for a constant delay, which is equivalent to a linear phase response.

5.6.1.2 Definition of Loss Parameters

The loss is the attenuation a wave experiences when traveling through the transmission line. In logarithmic representation, it can be modeled as the sum of a constant and a frequency-dependent part, where the frequency dependence is due to the skin effect.

In the limit case, where the length of the transmission line is considered to be "almost zero", the loss is considered constant:

$$Loss(f) = Loss_{DC}$$

Otherwise, if the loss at DC and one additional frequency f_1 is known (or measured), the loss at frequency f is approximated by:

$$Loss(f) = Loss_{DC} + (Loss(f_1) - Loss_{DC}) \cdot \sqrt{\frac{f}{f_1}}$$

If in addition the loss at a second frequency f_2 is known (or measured), then the loss can be approximated by:

$$Loss(f) = Loss_{DC} + (Loss(f_1) - Loss_{DC}) \cdot \left(\frac{f}{f_1}\right)^b, \text{ where } b = \frac{\log_{10} \left(\left| \frac{Loss(f_1)}{Loss(f_2)} \right| \right)}{\log_{10} \left(\frac{f_1}{f_2} \right)}$$

In practice, the frequency-dependent part is often dominant, so that $Loss_{DC}$ can be set to zero. Experimentally, the loss value at DC can be determined in a separate measurement at a very low frequency ($f \rightarrow 0$).

5.6.1.3 Auto Length

The "Auto Length" function adds an electrical length offset to the active trace's receive port, such that the residual delay of the active trace (defined as the negative derivative of the phase response) is minimized across a configurable frequency range. If "Delay" is the selected trace format, the entire trace is shifted in vertical direction and centered on zero. In phase format, the "Auto Length" corrected trace shows the deviation from linear phase.

Length and delay measurement, related settings

"Auto Length" is suited for length and delay measurements on transmission lines.

1. Connect a (non-dispersive) cable to a single analyzer port no. n and measure the reflection factor S_{nn} .
2. In the CHANNEL – [OFFSET EMBED] > "Offset" softtool tab, select "Auto Length".

The delay is displayed in the "Delay" field, the cable length (depending on the "Velocity Factor") in the "Mech. Length" field.

It is also possible to determine cable lengths using a transmission measurement. Note that "Auto Length" always provides the **single** cable length and the delay for propagation in **one** direction.

The analyzer provides alternative ways for delay measurements:

1. Measure the reflection factor and select TRACE – [FORMAT] > "Delay".
This yields the delay for propagation in forward and reverse direction and should be approx. twice the "Auto Length" result. For transmission measurements, both results should be approx. equal.
2. Measure the reflection factor and select TRACE – [FORMAT] > "Phase". Place a marker to the trace and activate TRACE – [TRACE CONFIG] > "Trace Statistics" > "Phase/EI Length".
This yields the delay in one direction and should be approx. equal to the "Auto Length" result.

The measurement results using trace formats and trace statistics functions depend on the selected delay aperture and evaluation range. "Auto Length" is particularly accurate because it uses all sweep points. For non-dispersive cables, aperture and evaluation range effects are expected to vanish.

Use TRACE – [MARKER] > "Set by Marker" > Zero Delay at Marker to set the delay at a special trace point to zero.

Preconditions for Auto Length, effect on measured quantities and exceptions

"Auto Length" is enabled if the measured quantity contains the necessary phase information as a function of frequency, and if the interpretation of the results is unambiguous:

- A frequency sweep must be active.
- The measured quantity must be an S-parameter, ratio, wave quantity, a converted impedance or a converted admittance.

The effect of "Auto Length" on S-parameters, wave quantities and ratios is to eliminate a linear phase response as described above. The magnitude of the measured quantity is not affected. Converted admittances or impedances are calculated from the corresponding "Auto Length" corrected S-parameters. Y-parameters, Z-parameters and stability factors are not derived from a single S-parameter, therefore "Auto Length" is disabled.

Auto Length for logical ports

The "Auto Length" function can be used for balanced port configurations as well. If the active test port is a logical port, then the same length offset must be assigned to both physical ports that are combined to form the logical port. If different length offsets have been assigned to the physical ports before, they are both corrected by the same amount.

5.6.1.4 Auto Length and Loss

The "Auto Length and Loss" function determines all offset parameters at the active trace's receive port such that the residual group delay of the active trace (defined as the negative derivative of the phase response) is minimized **and** the measured loss is minimized as far as possible across a configurable frequency range.

"Auto Length and Loss" involves a two-step procedure:

- An "Auto Length" correction modifies the phase of the measured quantity, minimizing the residual group delay. The magnitude of the measured quantity is not affected.
- The automatic loss correction modifies the magnitude of the measured quantity, leaving the (auto length-corrected) phase unchanged.

Preconditions for Auto Length and Loss, effect on measured quantities and exceptions

"Auto Length and Loss" is enabled if the measured quantity contains the necessary phase information as a function of the frequency, and if the interpretation of the results is unambiguous:

- A frequency sweep must be active.
- The measured quantity must be an S-parameter, ratio, wave quantity, a converted impedance or a converted admittance.

The effect of "Auto Length and Loss" on S-parameters, wave quantities and ratios is to eliminate a linear phase response and account for a loss as described above. Converted admittances or impedances are calculated from the corresponding "Auto Length and Loss" corrected S-parameters. Y-parameters, Z-parameters and stability factors are not derived from a single S-parameter, therefore "Auto Length and Loss" is disabled.

Calculation of loss parameters

The loss is assumed to be given in terms of the DC loss Loss_{DC} , the reference frequency f_{ref} , and the loss at the reference frequency $\text{Loss}(f_{\text{ref}})$. The formula used in the Auto Loss algorithm is similar to the formula for manual entry of the loss parameters (see [Chapter 5.6.1.2, "Definition of Loss Parameters"](#), on page 174).

The result is calculated according to the following rules:

- The reference frequency f_{ref} is kept at its previously defined value (default: 1 GHz).
- The DC loss c is zero except for wave quantities and for S-parameters and ratios with maximum dB magnitude larger than -0.01 dB.

- "Auto Length and Loss" for a wave quantity centers the corrected dB magnitude as close as possible around 0 dBm.
- "Auto Length and Loss" for S-parameters and ratios centers the corrected dB magnitude as close as possible around 0 dB.

The resulting offset parameters are displayed in the CHANNEL – [OFFSET EMBED] > "Offset" softtool tab.

Auto Length and Loss for balanced ports

The "Auto Length and Loss" function can be used for balanced port configurations as well. If the active test port is a balanced (logical) port, then the same offset parameters must be assigned to both physical ports that are combined to form the logical port. If different offset parameters have been assigned to the physical ports before, they are both corrected by the same amount.

5.6.1.5 Fixture Compensation

"Fixture Compensation" is an automated length offset and loss compensation for test fixtures. The analyzer performs a one-port reflection measurement at each port, assuming the inner contacts of the test fixtures to be terminated with an open or short circuit.

"Fixture Compensation" complements a previous system error correction and replaces a possible manual length offset and loss correction. For maximum accuracy, it is recommended to place the reference plane as close as possible towards the outer test fixture connectors using a full n-port calibration. The "Fixture Compensation" is then carried out in a second step, it only has to compensate for the effect of the test fixture connections.

The following features can further improve the accuracy of the fixture compensation:

- "Direct Compensation" provides a frequency-dependent transmission factor (instead of a global electrical length and loss).
- "Open and Short" causes the analyzer to calculate the correction data from two subsequent sweeps. The results are averaged to compensate for errors due to non-ideal terminations.

Auto Length and Loss vs. Direct Compensation

"Auto Length and Loss" compensation is a descriptive correction type: The effects of the test fixture connection are traced back to quantities that are commonly used to characterize transmission lines.

Use this correction type if your test fixture connections have suitable properties in the considered frequency range:

- The electrical length is approximately constant.
- The loss varies due to the skin effect.

"Direct Compensation" provides a frequency-dependent transmission factor. The phase of the transmission factor is calculated from the square root of the measured reflection factor, assuming a reciprocal test fixture. The sign ambiguity of this calcula-

ted transmission factor is resolved by a comparison with the phase obtained in an Auto Length calculation. This compensation type is recommended for test fixture connections that do not have the properties described above.

A "Direct Compensation" resets the offset parameters to zero.

Open/Short vs. Open and Short compensation

A non-ideal "Open" or "Short" termination of the test fixture connections during fixture compensation impairs subsequent measurements, causing an artificial ripple in the measured reflection factor of the DUT. If you observe this effect, an "Open and Short" compensation may improve the accuracy.

"Open and Short" compensation is more time-consuming because it requires two consecutive fixture compensation sweeps for each port, the first with an open, the second with a short circuit. The analyzer automatically calculates suitable averages from both fixture compensation sweeps to compensate for the inaccuracies of the individual "Open and Short" compensations.

5.6.1.6 Application and Effect of Offset Parameters

Offset and loss parameters can be particularly useful if the reference plane of the calibration cannot be placed directly at the DUT ports, e.g. because the DUT has non-coaxial ports and can only be measured in a test fixture. Offset parameters can also help to avoid a new complete system error correction if a cable with known properties has to be included in the test setup.

- A positive length offset moves the reference plane of the port towards the DUT, which is equivalent to deembedding the DUT by numerically removing a (perfectly matched) transmission line at that port.
- A negative offset moves the reference plane away from the DUT, which is equivalent to embedding the DUT by numerically adding a (perfectly matched) transmission line at that port.

The offset parameters are also suited for length and delay measurements; see [Chapter 5.6.1.3, "Auto Length"](#), on page 174. In contrast to the embedding/deembedding functions (see [Chapter 5.6.2, "Embedding and Deembedding"](#), on page 179) the parameters cannot compensate for a possible mismatch in the test setup.

Each offset parameter is assigned to a particular port. The delay parameters affect the phase of all measured quantities related to this port; the loss parameters affect their magnitude. An offset at port 1 affects the S-parameters S_{11} , S_{21} , S_{12} , S_{31} ... Some quantities (like the Z-parameters) depend on the whole of all S-parameters, so they are all more or less affected when one S-parameter changes due to the addition of an offset length.



To account for the propagation in both directions, the phase shift of a reflection parameter due to a given length offset is twice the phase shift of a transmission parameter. If, at a frequency of 300 MHz, the electrical length is increased by 250 mm ($\lambda/4$), then the phase of S_{21} increases by 90 deg, whereas the phase of S_{11} increases by 180 deg.

Equivalent relations hold for the loss.

If the trace is displayed in "Delay" format, changing the offset parameters simply shifts the whole trace in vertical direction.

The sign of the phase shift is determined as follows:

- A positive offset parameter causes a positive phase shift of the measured parameter and therefore reduces the calculated group delay.
- A negative offset parameter causes a negative phase shift of the measured parameter and therefore increases the calculated group delay.

5.6.1.7 Offset Parameters for Balanced Ports

The offset parameters can be used for balanced port configurations:

- Offset parameters must be assigned to both physical ports of a logical port.
- "Auto Length" corrects the length offset of both physical ports of a logical port by the same amount.

5.6.2 Embedding and Deembedding

The R&S ZND allows you to define virtual networks to be added to/removed from the measurement circuit for a DUT with single ended or balanced ports. This concept is referred to as embedding/deembedding.

The embedding/deembedding function has the following characteristics:

- Embedding and deembedding can be combined with balanced port conversion: the (de-)embedding function is available for single ended and balanced ports.
- A combination of four-port and two-port networks (not necessarily both) can be applied to balanced ports; two-port networks can be applied to single ended ports.
- A combination of four-port and two-port networks can be applied to any pair of single-ended ports. Moreover it is possible to combine several port pairs in an arbitrary order (port pair de-/embedding).
- Single-ended and/or balanced port (de-)embedding can be combined with ground loop (de-)embedding. A ground loop models the effect of a non-ideal ground connection of the DUT.
- Transformation networks can be defined by a set of S-parameters stored in a Touchstone file or by an equivalent circuit with lumped elements.
- The same networks are available for embedding and deembedding.

5.6.2.1 Embedding a DUT

To be integrated in application circuits, high-impedance components like Surface Acoustic Wave (SAW) filters are often combined with a matching network. To obtain the characteristics of a component with an added matching network, both must be integrated in the measurement circuit of the network analyzer.

The figure below shows a DUT with a single-ended and a balanced port that is combined with a real matching circuit and a physical unbalance-balance transformer (balun) to be evaluated in a 2-port measurement.

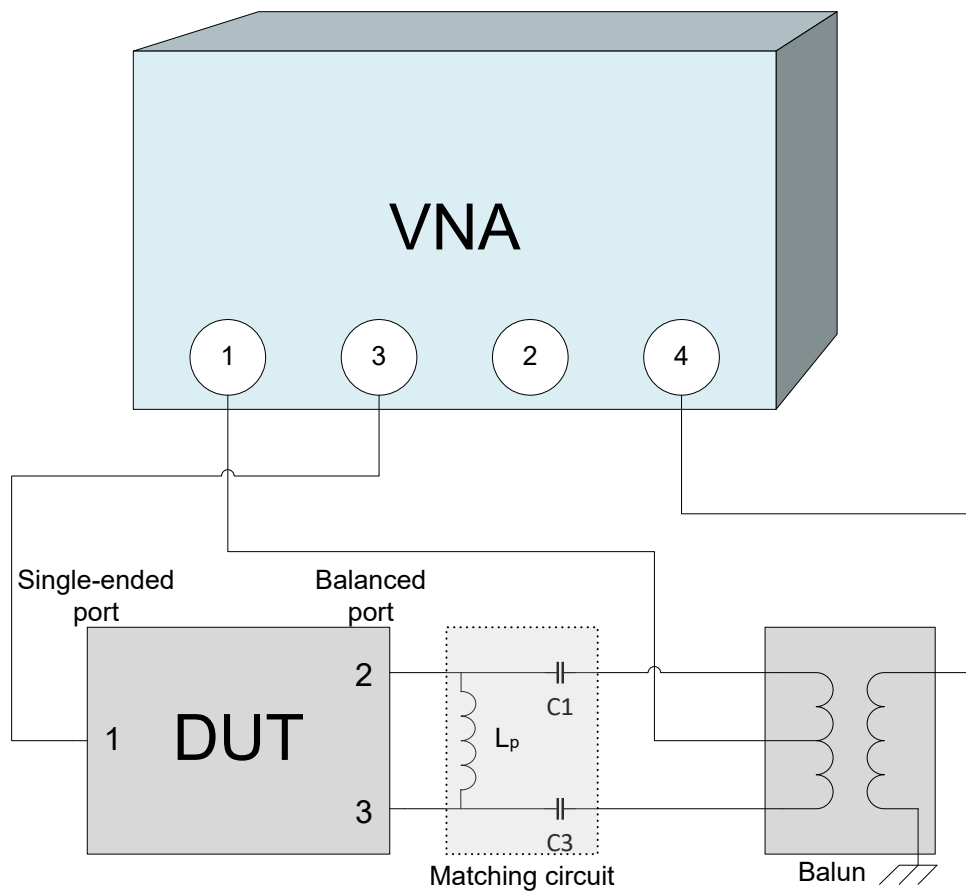

The idea of virtual embedding is to simulate the matching network and avoid using physical circuitry so that the analyzer ports can be directly connected to the input and output ports of the DUT. The matching circuit is taken into account numerically. The analyzer measures the DUT alone but provides the characteristics of the DUT, including the desired matching circuit.

This method provides a number of advantages:

- The measurement uncertainty is not impaired by the tolerances of real test fixtures.
- There is no need to fabricate test fixtures with integrated matching circuits for each type of DUT.
- Calibration can be performed at the DUT's ports. If necessary, (e.g. for compensating for the effect of a test fixture) it is possible to shift the calibration plane using length offset parameters.

5.6.2.2 Deembedding a DUT

Deembedding and embedding are inverse operations: A deembedding problem is given if an arbitrary real network connected to the DUT is to be virtually removed to obtain the characteristics of the DUT alone. Deembedding is typically used for DUTs which are not directly accessible because they are inseparably connected to other components, e.g. for MMICs in a package or connectors soldered to an adapter board.

To be numerically removed, the real network must be described by a set of S-parameters or by an equivalent circuit of lumped elements. Deembedding the DUT effectively extends the calibration plane towards the DUT ports, enabling a realistic evaluation of the DUT without the distorting network. Deembedding can be combined with length offset parameters; see [Chapter 5.6.1, "Offset Parameters"](#), on page 173.

The simplest case of single port deembedding can be depicted as follows:

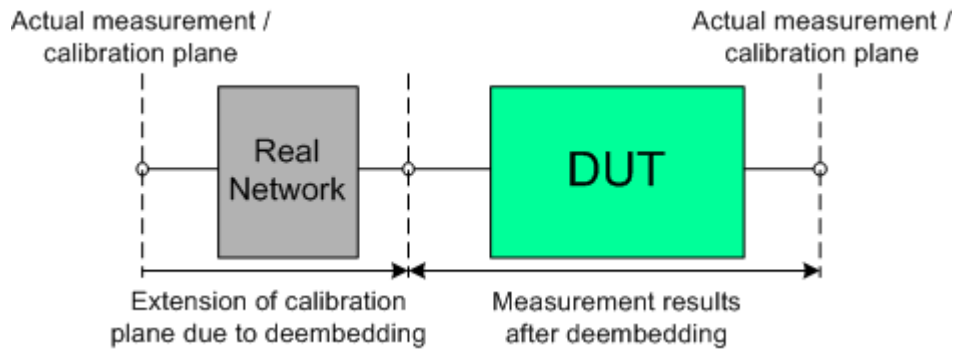

5.6.2.3 Circuit Models for 2-Port Networks

The lumped element 2-port transformation networks for (de-)embedding consist of the following two basic circuit blocks:

- a capacitor connected in parallel with a resistor
- an inductor connected in series with a resistor

The 2-port transformation networks comprise all possible combinations of 2 basic blocks, where either one block represents a serial and the other a shunt element or both represent shunt elements. In the default setting the resistors are not effective, since the serial resistances are set to 0Ω , the shunt resistances are set to $10 \text{ M}\Omega$ and the shunt inductances are set to 0 Siemens .

The first network is defined by its S-parameters stored in an imported two-port Touchstone file (*.s2p). No additional parameters are required.

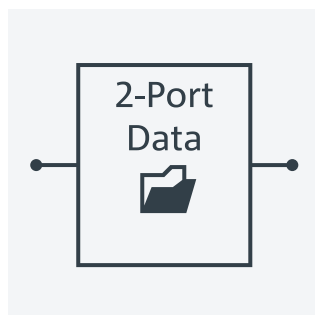

The following networks are composed of a serial capacitance C or inductance L (as seen from the test port), followed by a shunt L or C. They are named Serial C, Shunt L / Serial L, Shunt C / Serial C, Shunt C / Serial L, Shunt L.

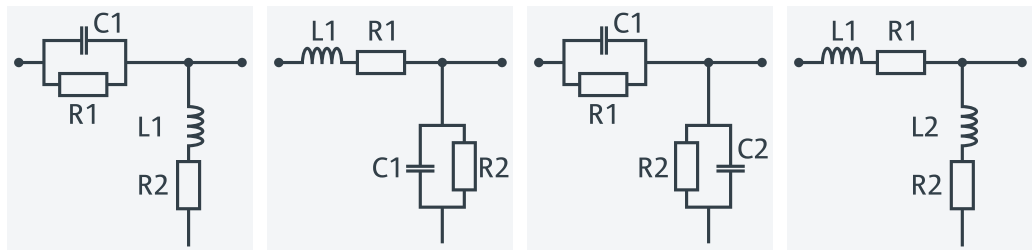

The following networks are composed of a shunt C or L (as seen from the analyzer port), followed by a serial C or L. They are named Shunt C, Serial L / Shunt L, Serial C / Shunt C, Serial C / Shunt L, Serial L.

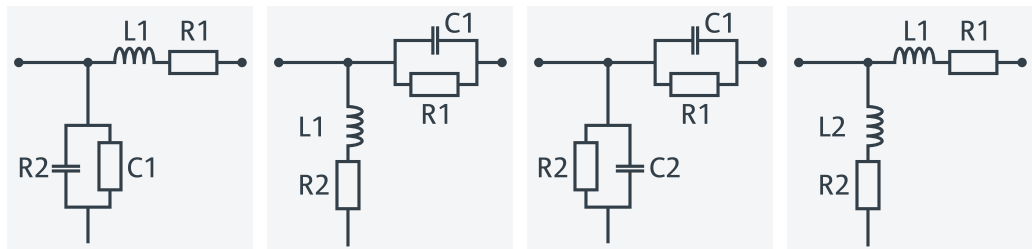

At the GUI, the "capacitance C_i in parallel with resistance R_i" circuit blocks can be replaced by equivalent "capacitance C_i in parallel with conductance G_i" circuit blocks.

In addition, there is also a Shunt L, Shunt C circuit model available, where the shunt C is defined as a capacitance C in parallel with a conductance G:

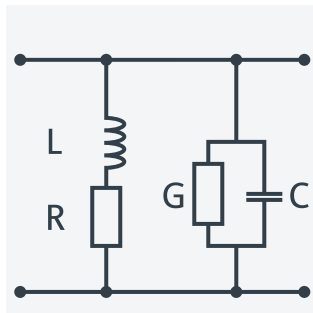

5.6.2.4 Circuit Models for 4-Port Networks

The lumped element 4-port transformation networks for (de-)embedding consist of the following two basic circuit blocks:

- A capacitor C connected in parallel with a resistor.
- An inductor L connected in series with a resistor.

The transformation networks comprise various combinations of 3 basic circuit blocks, where two blocks represent serial elements, the third a shunt element. In the default setting the resistors are not effective, since the serial R_s are set to 0 Ω, the shunt R_s are set to 10 MΩ. Moreover, the serial elements can be replaced by imported 2-port S-

parameters, or the entire transformation network can be described by imported 4-port S-parameters.

The first network is defined by its S-parameters stored in an imported four-port Touchstone file (*.s4p). No additional parameters are required.

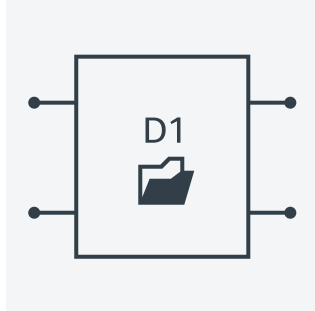

The following networks are composed of a shunt C or L and two serial elements, described by imported 2-port S-parameters. They are named *Serial 2-port, Shunt C* / *Serial 2-port, Shunt L* / *Shunt L, Serial 2-port* / *Shunt C, Serial 2-port*.

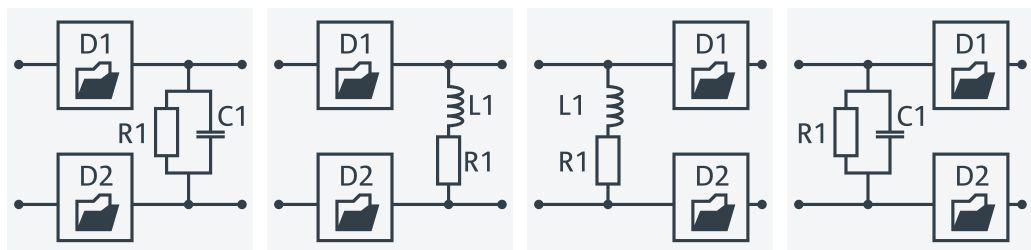

The following networks are composed of two serial Cs or Ls (as seen from the analyzer test port), followed by a shunt C or L. They are named *Serial Cs, Shunt L* / *Serial Ls, Shunt C* / *Serial Cs, Shunt C* / *Serial Ls, Shunt L*.

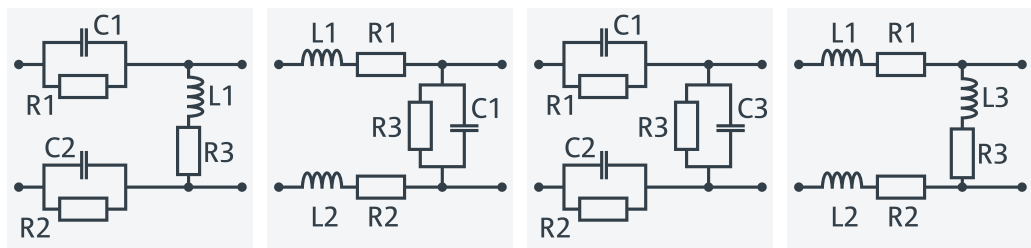

The following networks are composed of a shunt C or L (as seen from the analyzer test port), followed by two serial Cs or Ls. They are named *Shunt L, Serial Cs* / *Shunt C, Serial Ls* / *Shunt C, Serial Cs* / *Shunt L, Serial Ls*.

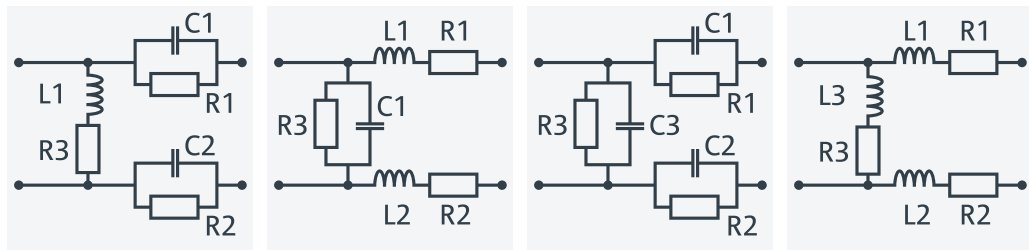

Since FW version 1.93, the "capacitance C<i></i> in parallel with resistance R<i></i>" circuit blocks can alternatively be represented as "capacitance C<i></i> in parallel with conductance G<i></i>" circuit blocks.

5.6.2.5 Port Pair De-/Embedding

Port pair de-/embedding extends the functionality of balanced port de-/embedding to pairs of single-ended physical ports. The analyzer uses the 4-port transformation networks known from balanced port de-/embedding, however, each transformation network is assigned to an arbitrary pair of (single-ended) physical ports.

A simple circuit which can be modeled using port pair (de-)embedding is a circuit (e.g. a resistance) between two ports of a DUT. To obtain the circuit in the following figure, select port pair 1,2 and the Serial Ls, Shunt L transformation network with all inductances set to zero ($L1 = L2 = L3 = 0$ H) and $R1 = R2 = 0$ Ω .

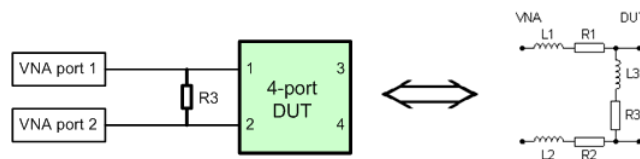

To model a general (de-)embedding network for ports 1 and 2, select port pair 1, 2 and a 4-Port Touchstone file.

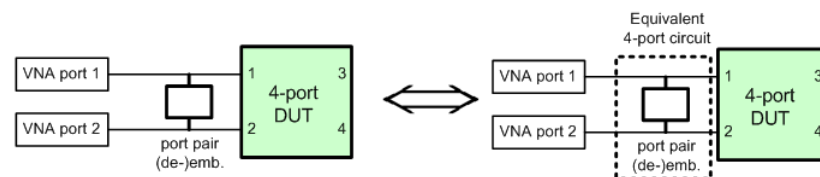

The R&S ZND FW handles Port Pair De-/Embedding as a special case of [Port Set De-/Embedding](#).

5.6.2.6 Port Set De-/Embedding

The port set de-/embedding feature allows de-/embedding a linear 2m-port network connecting m physical VNA ports to m physical DUT ports ($m \geq 2$).

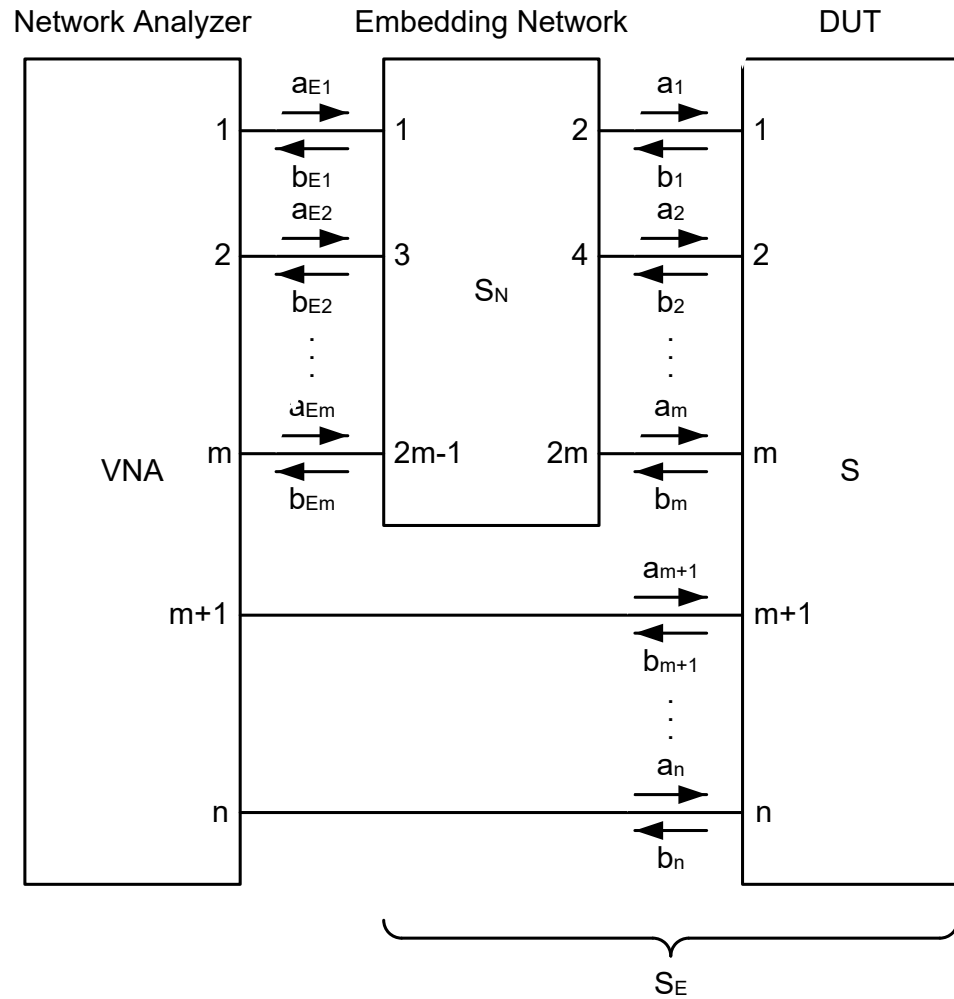
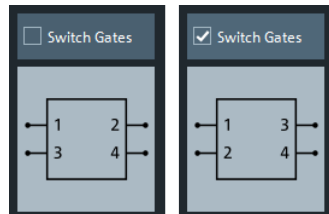

Figure 5-9: Port Set De-/Embedding

As shown in section [Combining Several De-/Embedding Networks](#), port set deembedding is calculated after single-ended deembedding, and the port set embedding step precedes single ended embedding. It is possible to combine a sequence of port sets for deembedding (embedding), each port set having its own transformation network. The effect of port set de-/embedding depends on the port sets themselves but also on their order. The same physical ports can be used repeatedly in different port sets; it is also possible to use the same port set repeatedly.



- For the R&S ZND, each port set can consist of $m = 2$ ports
- For these port pairs, the de-/embedding network can be defined either via lumped element model (possibly in combination with s2p Touchstone files) or via a s4p Touchstone file, see [Chapter 5.6.2.5, "Port Pair De-/Embedding"](#), on page 184.
- In case the port number conventions of the loaded Touchstone file differ from the numbering scheme depicted in [Figure 5-9](#), it is possible to "Switch Gates". The analyzer interchanges the port numbers when loading the file.



5.6.2.7 Ground Loop De-/Embedding

A ground loop models the effect of a non-ideal ground connection of the DUT causing a difference in potential between the analyzer's and the DUT's ground reference. A typical and often unavoidable source of ground loops is the parasitic inductance of the ground contacts.

In contrast to the 2-port de-/embedding networks, the ground loop represents a single-wire connection that can be described by a one-port S-matrix. On the other hand, the ground loop de-/embedding algorithm for an n-port DUT involves matrix operations which are based on the complete uncorrected single-ended $n \times n$ S-matrix.

The Ground Loop De-/Embedding can be specified via Touchstone s1p file or by parametrizing one of the lumped element models "Shunt L", "Shunt C".

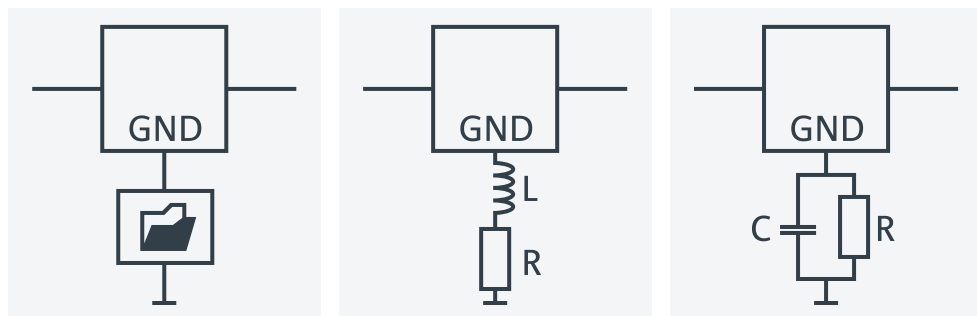

5.6.2.8 Differential Match Embedding

Differential Match Embedding allows you to simulate the characteristics of balanced DUT ports whose differential mode is balance-unbalance converted and then connected to a port-specific matching circuit.

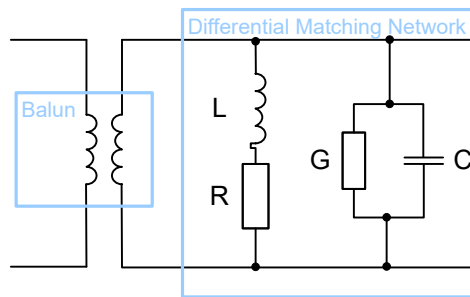

In contrast to standard balanced embedding (4-port), the matching circuit is only applied to the differential mode port (2-port). It can be specified via a Touchstone s2p file or by parametrizing a lumped "Shunt L, Shunt C" element model.

5.6.2.9 Fixture Modeling and Deembedding

When performing tasks such as verifying digital high-speed signal structures on printed circuit boards (PCBs), measurements have to be carried out on certain layers without the effects of probes, probe pads, vias, lead-ins and lead-outs. This requires the use of accurate deembedding algorithms to calculate and remove these effects from the measurements, leaving only the result for the area of interest.

Instead of asking the user to define the fixture by parametrizing one of the given lumped circuit models or by "somehow" providing a suitable `snp` file, the firmware of the R&S ZND now also provides integration for third-party tools that model the test fixture from measured data:

- AtaiTec's *In Situ De-Embedding* (ISD), see <http://ataitec.com/products/isd/>
A pre-installed or service-retrofitted version is available with option R&S ZND-K220
- PacketMicro's *Smart Fixture De-embedding* (SFD), see <https://www.packetmicro.com/Products/sfd-tool.html>
A pre-installed or service-retrofitted version is available with option R&S ZND-K230
- **Eazy De-embedding Based on IEEE 370** (option R&S ZND-K210)

The tools are integrated into the deembedding functionality of the analyzer firmware.

More fixture modeling tools may be added in future releases of the R&S ZND firmware.

Test Setup

The setup below shows an example for verifying the high-speed differential signal lines on a PCB.

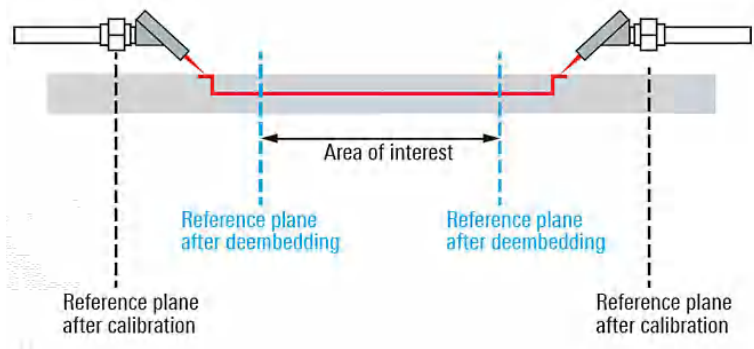

Fixture Modeling Process

For all supported tools, the fixture modeling proceeds as follows:

1. Perform a calibration to the fixture connectors.
2. Measure one or more PCB test coupons for the related fixture.
The results are independent of a particular DUT. Hence they can be reused for subsequent measurements using the same test fixture.
3. Measure the total structure, i.e. the DUT with the fixture.
4. Run the selected third-party tool to calculate the fixture deembedding files.

After a final confirmation, the calculated deembedding files (s_{2p} for single-ended ports, s_{4p} for balanced ports) are used for deembedding the DUT at the respective logical port(s).

Test Coupons

The test fixture consists of a set of lead-ins.

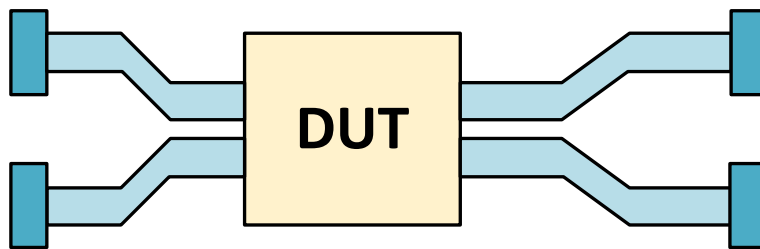

Figure 5-10: DUT with Test Fixture (balanced)

The fixture modeling tools require test coupons for the lead-ins to the DUT and that are either representing a Through, an Open or a Short. If the lead-ins "on the left" and "on the right" side of the DUT ("lead-outs") are not symmetric, different test coupons for the lead-ins and lead-outs are required.

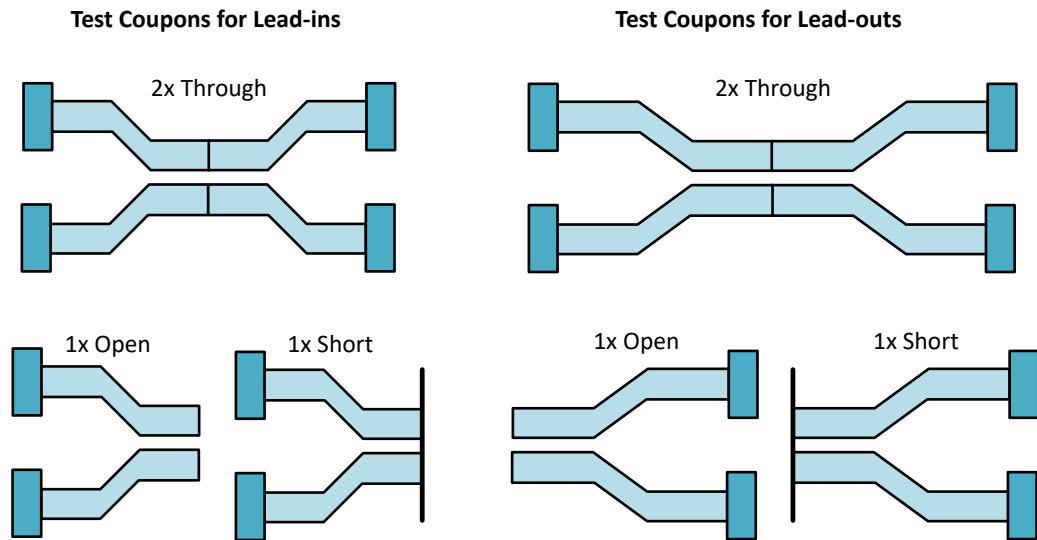

Figure 5-11: Test Coupons (balanced)

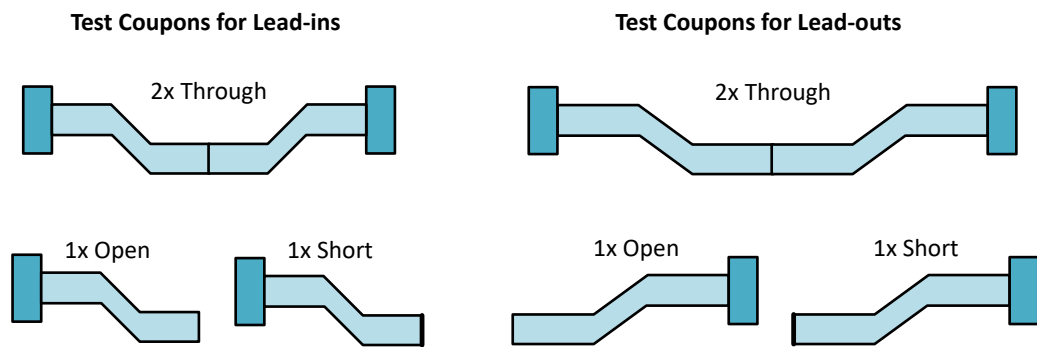

Figure 5-12: Test Coupons (single-ended)



The R&S ZND's current implementation of the fixture modeling tool support assumes symmetrical lead-ins and lead-outs.

5.6.2.10 Combining Several De-/Embedding Networks

The R&S ZND allows you to select a combination of networks to be numerically added/removed at different layers

- 2-port networks at single ended physical ports
- 4-port networks at pairs of single ended physical ports
- 4-port networks at balanced logical ports
- 1-port ground loop networks
- 2-port differential match embedding networks at balanced logical ports

The different steps for deembedding and embedding are carried out in the following order:

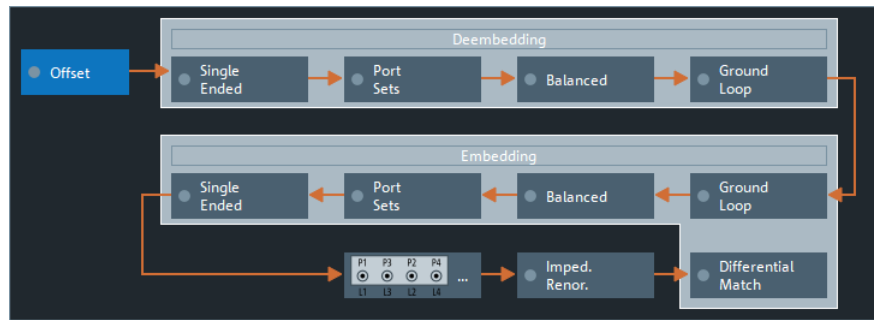

Figure 5-13: De-/Embedding calculation flow

This means that the real networks are removed before virtual networks are added.

The (de-)embedding steps are carried out in the following order:

1. Single Ended Deembedding: every physical port can be deembedded from a single 2-port network
2. Port Set Deembedding: every port pair can be deembedded from a sequence of 4-port networks.
3. Balanced Deembedding: every balanced logical port can be deembedded from a single 4-port network
4. Ground Loop Deembedding: the DUT's ground connection can be deembedded from a single 1-port network
5. Ground Loop Embedding: the DUT's ground connection can be embedded in a single 1-port network
6. Balanced Embedding: every balanced logical port can be embedded in a single 4-port network
7. Port Set Embedding: every port set can be embedded in a sequence of 4-port networks.
8. Single Ended Embedding: every physical port can be embedded in a single 2-port network
9. Differential Match Embedding: the differential mode of a balanced logical port can be embedded in a single 2-port network

1. Initial situation: DUT embedded in 2-port and 4-port networks (only 1 port shown)

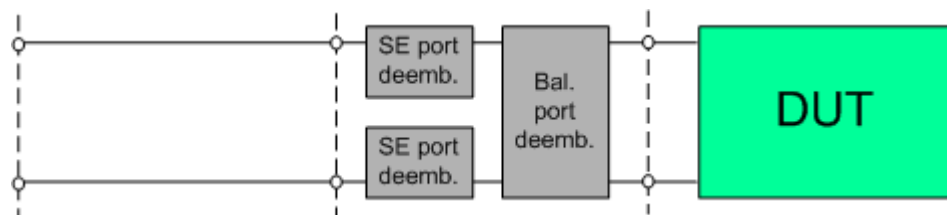

2. Single ended deembedding

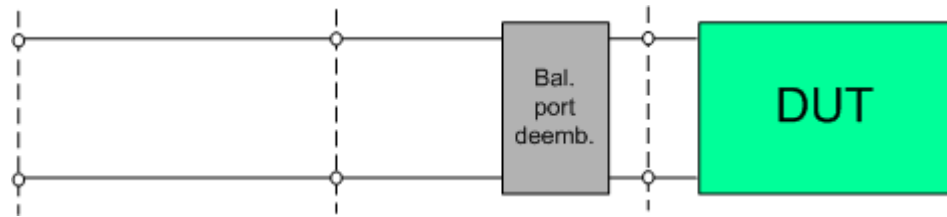

3. Balanced port deembedding



4. Balanced port embedding



5. Single ended port embedding



5.7 Optional Extensions and Accessories

The instrument can be upgraded with various software and hardware options, providing enhanced flexibility and an extended measurement functionality. The equipped options are listed in the "Options" tab of the [Info Dialog](#) (SYSTEM – [SETUP] > "Setup" > "Info...").

For a complete list of options, accessories, and extras refer to the product brochure or to the "Options" section of the R&S ZND product pages on the Internet.

The following sections provide an introduction to the software and hardware options described in this documentation. The use of external power meters and switch matrices does not require any additional hardware or software options; it is described at the end of the chapter.

5.7.1 Frequency Range Extension to 8.5 GHz for unidirectional R&S ZND

Option R&S ZND-K1

Software option R&S ZND-K1 increases the upper frequency limit of a unidirectional R&S ZND (i.e. not equipped with R&S ZND-K5) from 4.5 GHz to 8.5 GHz.



Recalibration Required

Although this is a software option, the R&S ZND has to be recalibrated at Rohde & Schwarz service to comply with the specifications of the data sheet.

5.7.2 Bidirectional Measurements 100 kHz to 4.5 GHz for R&S ZND

Option R&S ZND-K5

Software option R&S ZND-K5 enables bidirectional measurements for a R&S ZND with standard frequency range (i.e without option R&S ZND-K1).



Recalibration Required

Although this is a software option, the R&S ZND has to be recalibrated at Rohde & Schwarz service to comply with the specifications of the data sheet.

5.7.3 Bidirectional Measurements 100 kHz to 8.5 GHz for R&S ZND

Option R&S ZND-K6

Software option R&S ZND-K6 enables bidirectional measurements for a R&S ZND with extended frequency range (i.e.with option R&S ZND-K1).



Recalibration Required

Although this is a software option, the R&S ZND has to be recalibrated at Rohde & Schwarz service to comply with the specifications of the data sheet.

5.7.4 Frequency Range Extension to 8.5 GHz for bidirectional R&S ZND

Option R&S ZND-K8

Increases the upper frequency limit of a bidirectional R&S ZND (i.e. equipped with R&S ZND-K5) from 4.5 GHz to 8.5 GHz.



Recalibration Required

Although this is a software option, the R&S ZND has to be recalibrated at Rohde & Schwarz service to comply with the specifications of the data sheet.

5.7.5 Time Domain Analysis

Option R&S ZND-K2

The network analyzer measures and displays complex S-parameters and other quantities as a function of the frequency. The measurement results can be filtered and mathematically transformed to obtain the time domain representation, which often gives a clearer insight into the characteristics of the DUT.

Time domain transforms can be calculated in band pass or low pass mode. For the latter, the analyzer offers the impulse and step response as two alternative transformation types. A wide selection of windows can be used to optimize the time domain response and suppress side lobes due to the finite sweep range. Moreover, it is possible to eliminate unwanted responses using a time gate and transform the gated result back into the frequency domain.

For a detailed discussion of the time domain transformation including many examples, refer to the application note 1EP83 which is available on the R&S internet at <http://www.rohde-schwarz.com/appnotes/1EP83>.

Trace selection

Select a reflection parameter S_{ii} to perform a time domain reflectometry (TDR) measurement, e.g. to detect cable faults. To measure the impedance of a network, you can select a [converted impedance parameter](#) $Z \leftarrow S_{ii}$.

Select a transmission parameters S_{ij} ($i \neq j$) to perform a time domain transmission (TDT) measurement, e.g. for measuring antennas.



For TDR traces and if distance is used as the x axis, the x value indicates the **one-way** path to the reflection.

5.7.5.1 Chirp z-Transformation

The Chirp z-transformation that the analyzer uses to compute the time domain response is an extension of the (inverse) Fast Fourier Transform (FFT). Compared to the FFT, the number of sweep points is arbitrary (not necessarily an integer power of 2), but the computation time is increased by approx. a factor of 2. This increased computation time is usually negligible compared to the sweep times of the analyzer.

The following properties of the Chirp z-transformation are relevant for the analyzer settings:

- The frequency points must be equidistant.

- The time domain response is repeated after a time interval which is equal to $\Delta t = 1/\Delta f$, where Δf is the spacing between two consecutive sweep points in the frequency domain. For a sweep span of 4 GHz and 201 equidistant sweep points, $\Delta f = 4 \text{ GHz}/200 = 2 \cdot 10^7 \text{ Hz}$, so that $\Delta t = 50 \text{ ns}$. Δt is termed measurement range (in time domain) or unambiguous range.

Additional constraints apply if the selected Chirp z-transformation is a lowpass transformation.

5.7.5.2 Band Pass and Low Pass Mode

The analyzer provides two different types of time domain transforms:

- **Band pass mode:** The time domain transform is based on the measurement results obtained in the sweep range between any set of positive start and stop values. The sweep points must be equidistant. No assumption is made about the measurement point at zero frequency (DC value). The time domain result is complex, with an undetermined phase depending on the delay of the signal.
- **Low pass mode:** The measurement results are continued towards $f = 0$ (DC value) and mirrored at the frequency origin so that the effective sweep range (and thus the response resolution) is more than doubled. Together with the DC value, the condition of equidistant sweep points implies that the frequency grid must be harmonic. Due to the symmetry of the trace in the frequency domain, the time domain result is harmonic.

See also [Chapter 5.7.5.4, "Harmonic Grid"](#), on page 195.

Two different types of response are available in low pass mode; see below.

Table 5-15: Comparison of band pass and low pass modes

Transform type	Band pass	Low pass
Advantages	Easiest to use: works with any set of equidistant sweep points	Higher response resolution (doubled) Includes information about DC value Real result Impulse and step response
Restrictions	No step response Undetermined phase	Needs harmonic grid
Use for...	Scalar measurements where the phase is not needed DUTs that do not operate down to $f = 0$ (e.g. pass band or high pass filters)	Scalar measurements where the sign is of interest DUTs with known DC value

Impulse and step response

In low pass mode, the analyzer can calculate two different types of responses:

- The impulse response corresponds to the response of a DUT that is stimulated with a short pulse.
- The step response corresponds to the response of a DUT that is stimulated with a voltage waveform that transitions from zero to unity.

The two alternative responses are mathematically equivalent; the step response can be obtained by integrating the impulse response:

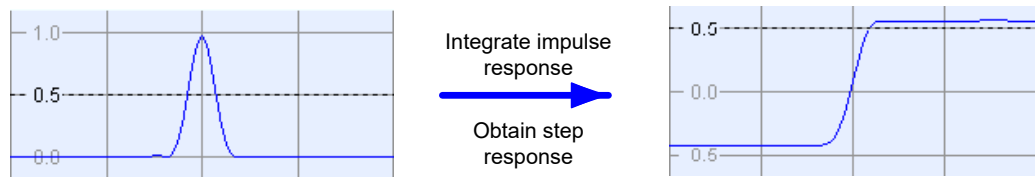

The step response is recommended for impedance measurements and for the analysis of discontinuities (especially inductive and capacitive discontinuities). The impulse response has an unambiguous magnitude and is therefore recommended for most other applications.

5.7.5.3 Windows in the Frequency Domain

The finite sweep range in a frequency domain measurement with the discontinuous transitions at the start and stop frequency broadens the impulses and causes side lobes (ringing) in the time domain response. The windows offered in the "Define Transform" dialog can reduce this effect and optimize the time domain response. The windows have the following characteristics:

Table 5-16: Properties of frequency windows

Window	Side lobe suppression	Relative impulse width	Best for...
No Profiling (Rectangle)	13 dB	1	–
Low First Side lobe (Hamming)	43 dB	1.4	Response resolution: separation of closely spaced responses with comparable amplitude
Normal Profile (Hann)	32 dB	1.6	Good compromise between pulse width and side lobe suppression
Steep Falloff (Bohman)	46 dB	1.9	Dynamic range: separation of distant responses with different amplitude
Arbitrary Side lobes (Dolph-Chebyshev)	User defined between 10 dB and 120 dB	1.2 (at 32 dB side lobe suppression)	Adjustment to individual needs; tradeoff between side lobe suppression and impulse width

5.7.5.4 Harmonic Grid

A harmonic grid is formed by a set of equidistant frequency points f_i ($i = 1 \dots n$) with spacing Δf and the additional condition that $f_1 = \Delta f$. In other words, all frequencies f_i are set to harmonics of the start frequency f_1 .

If a harmonic grid, including the DC value ($f = 0$), is mirrored to the negative frequency range, the result is again an equidistant grid.

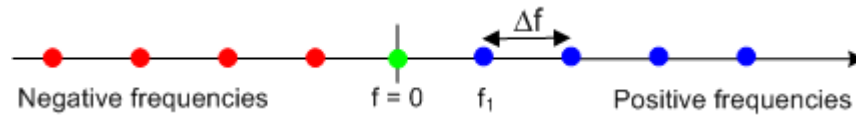

The point symmetry with respect to the DC value makes harmonic grids suitable for lowpass time domain transformations.

Visualization of the harmonic grid algorithms

The R&S ZND provides three different algorithms for harmonic grid calculation. The three harmonic grids have the following characteristics:

- Keep "Stop Frequency and Number of Points" means that the stop frequency and the number of sweep points is maintained. The sweep points are redistributed across the range between the minimum frequency of the analyzer and the stop frequency; the step width can be increased.

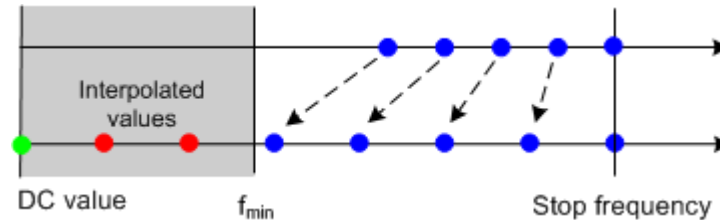

- Keep "Frequency Gap and Number of Points" means that the number of sweep points and their relative spacing is maintained. If the start frequency of the sweep is sufficiently above the f_{min} , the entire set of sweep points is shifted towards lower frequencies so that the stop frequency is decreased.

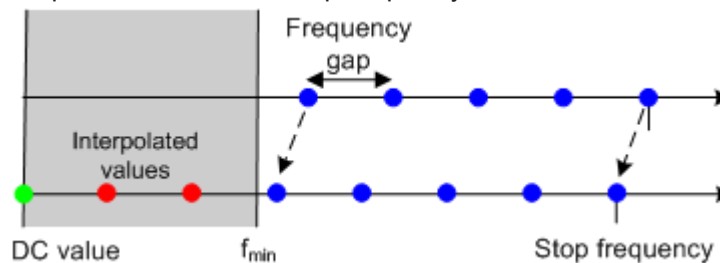

If the start frequency of the sweep is close to f_{min} , then the sweep points can have to be shifted towards higher frequencies. If the last sweep point of the calculated harmonic grid exceeds the maximum frequency of the analyzer, then an error message is displayed, and another harmonic grid algorithm must be used.

- Keep "Stop Frequency and Approximate Frequency Gap" means that the stop frequency is maintained and the number of sweep points is increased until the range between f_{min} and the stop frequency is filled. The frequency gap is approximately maintained.

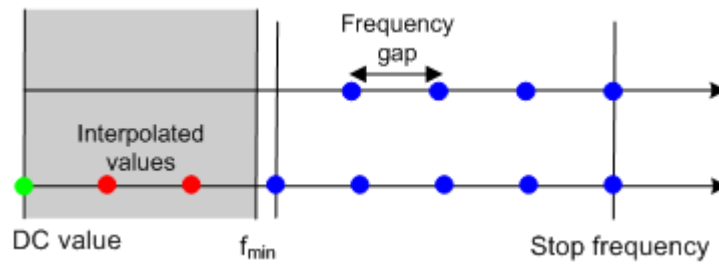

The figures above are schematic and do not comply with the conditions placed on the number of sweep points and interpolated/extrapolated values.



The harmonic grids cannot be calculated for any set of sweep points. If the minimum number of sweep points is smaller than 5, then the interpolation/extrapolation algorithm for additional sweep points does not work. The same is true if the number of sweep points or stop frequency exceeds the upper limit. Besides, the ratio between the sweep range and the interpolation range between $f = 0$ and $f = f_{\min}$ must be large enough to ensure accurate results. If the sweep range for the harmonic grid exceeds the frequency range of the current system error correction, a warning is displayed.

Finding the appropriate algorithm

The three types of harmonic grids have different advantages and drawbacks. Note that for a bandpass transformation the grid parameters have the following effect:

- A wider sweep range (i.e. a larger bandwidth) increases the time domain resolution.
- A smaller frequency gap extends the unambiguous range.
- A larger number of points increases the sweep time.

With default analyzer settings, the differences between the grid types are small. The following table helps you find the appropriate grid.

Table 5-17: Properties of grid types

Grid type: Keep	Sweep time	Time domain resolution	Unambiguous range	Algorithm fails if...
Stop freq. and no. of points	➡	⬆	⬇	–
Freq. gap and no. of points	➡	➡	➡	Stop frequency beyond upper frequency limit
Stop freq. and approx. freq. gap	⬆	⬆	➡	Number of sweep points beyond limit

5.7.5.5 Time Gates

A time gate is used to eliminate unwanted responses that appear on the time domain transform. An active time gate acts on the trace in time domain and in frequency domain representation.

The properties of the time gates are analogous to the properties of the frequency domain windows. The following table gives an overview:

Table 5-18: Properties of time gates

Window	Side lobe suppression	Passband ripple	Best for...
Steepest Edges (Rectangle)	13 dB	0.547 dB	Eliminate small distortions in the vicinity of the useful signal, if demands on amplitude accuracy are low
Steep Edges (Hamming)	43 dB	0.019 dB	Good compromise between edge steepness and side lobe suppression
Normal Gate (Hann)	32 dB	0.032 dB	Good compromise between edge steepness and side lobe suppression
Maximum Flatness (Bohman)	46 dB	0 dB	Maximum attenuation of responses outside the gate span
Arbitrary Gate Shape (Dolph-Chebyshev)	User defined between 10 dB and 120 dB	0.071 dB	Adjustment to individual needs; tradeoff between side lobe suppression and edge steepness

Time-Gated Frequency Domain Trace

The trace in the frequency domain depends on the state of the "Time Gate":

- If the gate is disabled, the frequency domain (FD) trace corresponds to the measured sweep results before the time-domain transformation.
- If the gate is enabled, the displayed frequency domain trace is calculated from the time domain (TD) trace which is gated and transformed back into the frequency domain.

The analyzer uses fixed "No Profiling (Rectangle)" window settings to transform the measured trace into time domain. The TD trace is gated using the selected time gate. The gated trace is transformed back into frequency domain using a "No Profiling (Rectangle)" window.

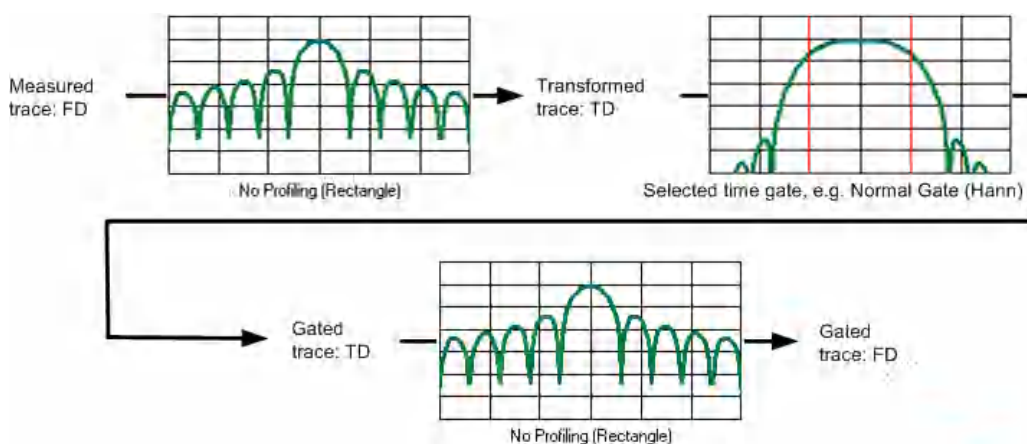

The shape, width and position of the time gate affect the gated frequency domain trace. The window type selection in the "Define Transform" dialog is ignored. The selected window is used again when the TD trace is displayed ("Time Domain: On").

The rectangular "No Profiling (Rectangle)" windows minimize numerical inaccuracies near the boundaries of the measured frequency span. In the limit where the effect of the time gate vanishes (e.g. a gate of type "Notch" and a very small width), the time gated trace is equal to the original measured trace.

5.7.5.6 Time Domain S_{VSWR} Measurements

The vector network analyzer R&S ZND with time domain option K2 supports TD site VSWR measurements.



For the frequency range 1 GHz to 18 GHz, this method of S_{VSWR} measurement is proposed in standard ANSI C63.25.

EMC Test Site Validation

EMC test sites for radiated emission measurements rely on free-space conditions to minimize the influence of reflections on the received signal. Practically, near free-space conditions are achieved by shielded enclosures fully lined with RF absorbing material. *Site validation* determines deviations from free-space conditions that must meet the acceptance criterion for making EMC compliance measurements in a FAR (= fully anechoic room). It is performed by measuring the *site voltage standing-wave ratio* (S_{VSWR}), which is the ratio of maximum received signal to minimum received signal, caused by interference between direct (intended) and reflected signals.

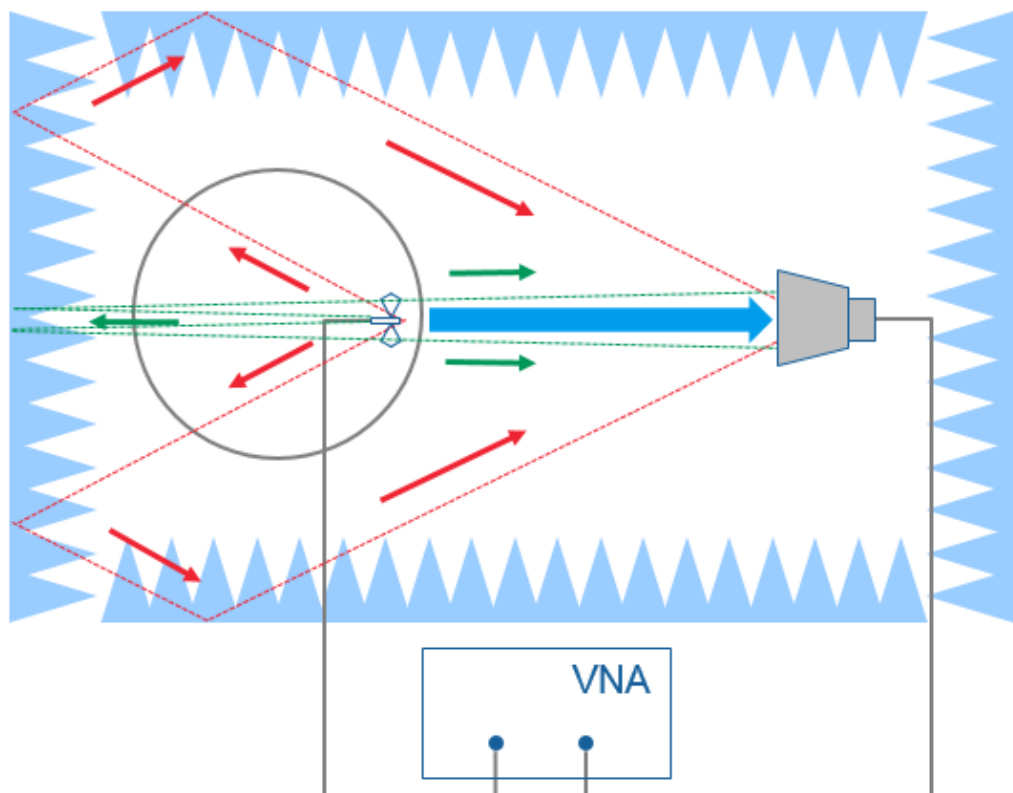

blue arrow = direct signal
 red and green arrows = reflected signal

TD S_{VSWR} Calculation

The ANSI time-domain method relies on a complex transmission measurement (S_{21}) using a vector network analyzer (VNA).

A time-domain transformation of the frequency domain data shows the impulse response between the two antennas. Since the direct antenna-to-antenna response is related to the shortest distance, the earliest impulse is the direct antenna response. Reflections from the test site are from farther distance away, thus come at later time. It is therefore possible to separate the direct antenna response $S_{21, \text{direct}}$ from reflections $S_{21, \text{reflected}}$ by using time gating and to calculate

$$\text{TD } S_{VSWR} = (1+r) / (1-r) ,$$

where $r = S_{21, \text{reflected}} / S_{21, \text{direct}}$.

Measurement Procedure for ANSI C63.25

See the Rohde & Schwarz Application Card "Fast validation of EMC Test Sites above 1 GHz with Time-domain S_{VSWR} ", published on the Rohde & Schwarz internet site.

5.7.6 Distance-to-Fault Measurements

Option R&S ZND-K3

With option K3 "Distance-to-Fault", the R&S ZND can locate faults and discontinuities on cables and transmission lines.

Faults produce peaks on the impulse response (in the time domain) that is calculated from the measured reflection S-parameter trace via inverse Fourier transformation. The distance between the reference plane and the fault can then be calculated from the propagation time, accounting for the electrical properties of the transmission line. Moreover it is possible to define the peaks to be considered as being caused by a fault.

The following example shows the reflection at the end of a faultless open cable connected to test port 2. A full one-port calibration ensures that the distance is measured from the test port position (reference plane = distance zero). The horizontal position of marker "M2" corresponds to the cable length of 1417 mm, the additional peak at position "M1" is due to a bad connection between the cable and the test port.



Adjust the frequency sweep to the length of the transmission line and the expected distance to fault:

- The maximum distance that can be measured is proportional to the number of sweep points. The larger the number of sweep points, the longer the maximum distance between the calibrated reference plane and the fault to be located.
- The maximum distance that can be measured is inversely proportional to the frequency span. The smaller the frequency span, the longer the maximum distance between the calibrated reference plane and the fault to be located. However, a smaller frequency span comes at the cost of a coarser distance resolution.

The R&S ZND can automatically determine a suitable number of sweep points for a given maximum distance to fault ("Auto Number of Points"). Moreover it is possible to define which of the peaks are considered as being due to a fault, and to draw up and export a list of the detected faults.



- For a unidirectional R&S ZND, only port 1 can be used for distance-to-fault measurements.
- A more flexible approach with additional configuration possibilities is available with time domain option R&S ZND-K2 (see [Chapter 5.7.5, "Time Domain Analysis"](#), on page 193).

5.7.7 Frequency Resolution 1 mHz

Option R&S ZND-K19

This software option improves the frequency resolution of a R&S ZND to 1 mHz.

5.7.8 Eazy De-embedding Based on IEEE 370

Option R&S ZND-K210

EaZy Deembedding (EZD) is an implementation of the IEEE algorithm for generating deembedding files from a symmetrical 2x thru measurement.

Option R&S ZND-K210 allows you to model a test fixture using the EZD fixture modeling tool and to deembed selected ports using the generated touchstone files.

The EZD fixture modeling proceeds in the following steps:

1. Measure one or more test coupons for the related fixture.
2. Run the EZD tool to calculate the Touchstone files modeling the test fixture.

The calculated s_{Np} files can then be used to deembed the DUT at selected ports.

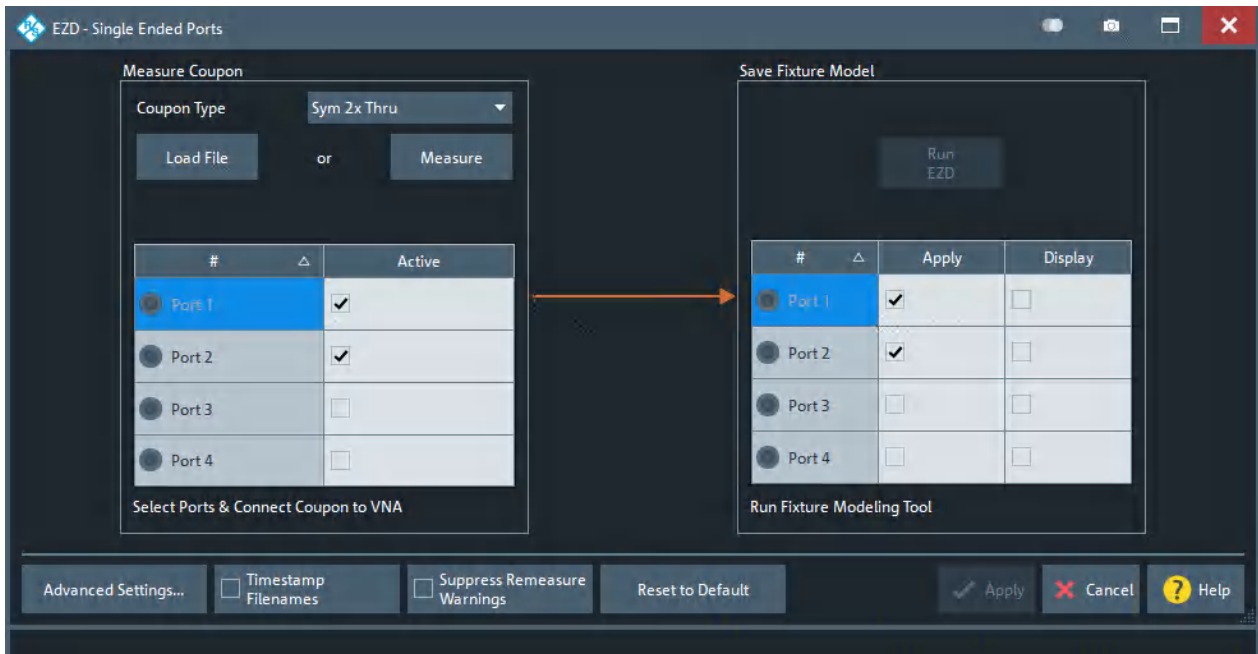

Figure 5-14: Fixture modeling: EZD – Single Ended Ports dialog

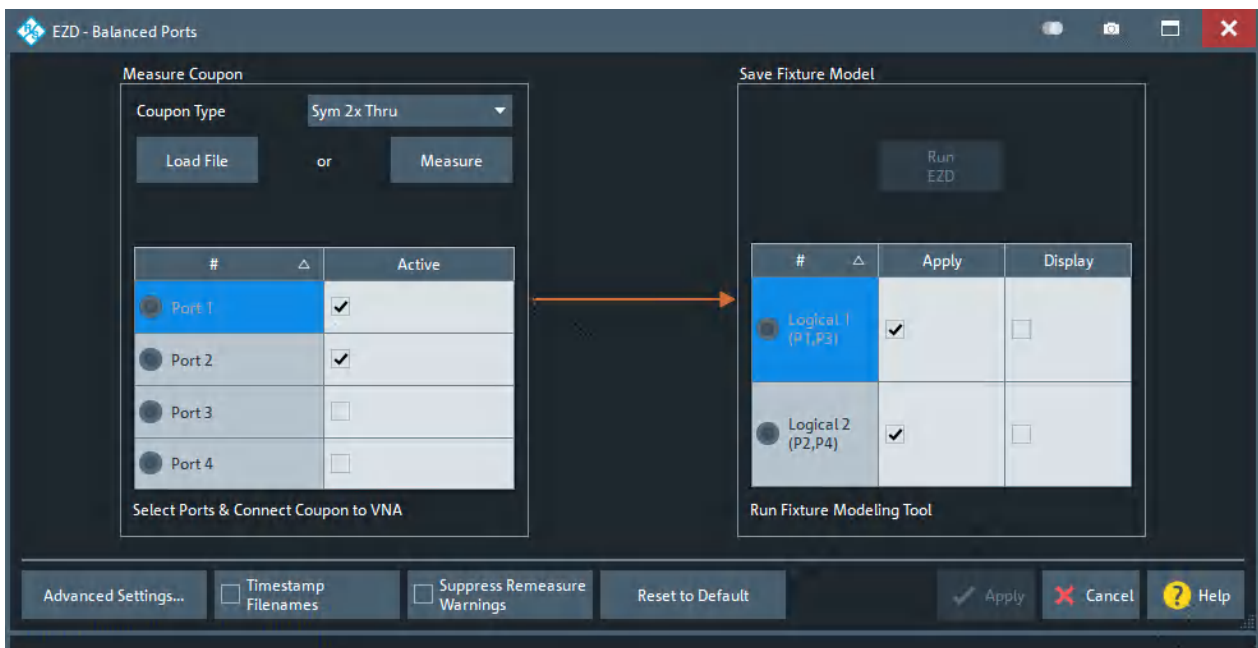

Figure 5-15: Fixture modeling: EZD – Balanced Ports dialog



- For general information about fixture de-embedding, see [Chapter 5.6.2.9, "Fixture Modeling and Deembedding"](#), on page 187.
- Option R&S ZND-K210 can be ordered with a new instrument or retrofitted at Rohde&Schwarz service.

5.7.9 In-situ De-Embedding

Option R&S ZND-K220

This option offers a pre-installed or service-retrofitted version of AtaiTec's *In Situ De-Embedding* (ISD) tool for fixture de-embedding.

The tool is integrated into the de-embedding functionality of the analyzer firmware.



- For general information about fixture de-embedding, see [Chapter 5.6.2.9, "Fixture Modeling and Deembedding"](#), on page 187.
- For detailed information about the ISD tool, see the product pages at <http://atai-tec.com/products/isd/>

5.7.10 Smart Fixture De-Embedding

Option R&S ZND-K230

This option offers a pre-installed or service-retrofitted version of PacketMicro's *Smart Fixture De-embedding* (SFD) for fixture de-embedding.

The tool is integrated into the de-embedding functionality of the analyzer firmware.



- For general information about fixture de-embedding, see [Chapter 5.6.2.9, "Fixture Modeling and Deembedding"](#), on page 187.
- For detailed information about the SFD tool, see the product pages at <https://www.packetmicro.com/Products/sfd-tool.html>.

5.7.11 Delta-L 4.0 PCB Characterization

Option R&S ZND-K231

Delta-L is a de-embedding methodology developed by Intel Corporation and is used for de-embedding strip lines that include vias. Delta-L calculates the loss of PCB interconnects and can be performed on single-ended or balanced interconnects.

The objective of Delta-L is to determine an insertion loss measurement defined on two or more coupon lines of differing lengths. This ratio of insertion loss in dB/inch can be applied to any trace length with similar vias.



For background information, see

- <https://www.intel.com/content/dam/www/public/us/en/documents/guides/delta-l-plus-methodology-for-electrical-characterization-guide.pdf>
- <https://ieeexplore.ieee.org/document/7048423>

The R&S ZND uses the Clear Signal Solutions AITT-DL implementation of the Delta-L v4.0 algorithms (see <https://clearsig.com/clearsig/tools/#Delta>). It allows you to perform:

- 1L (one line/length) analysis
Typically used for high-volume manufacturing (relative comparison)
- 2L analysis
Typically used for board-quality validation (removes the test fixture impact)
- 3L analysis
Typically used for material characterization (best accuracy, self-validation of results).

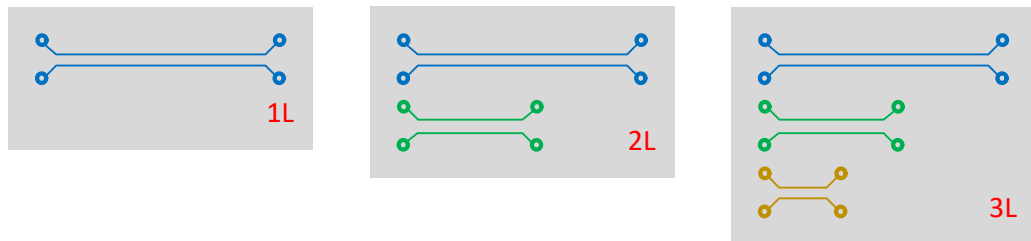

Figure 5-16: Test coupons for 1L, 2L and 3L measurements



Option R&S ZND-K231 can be ordered with a new instrument or retrofitted at Rohde&Schwarz service.

5.7.12 Health and Usage Monitoring Service (HUMS)

Option R&S ZND-K980

The R&S ZND comes with a health and utilization monitoring system (HUMS) providing information about the R&S ZND. Aim is to increase the overall utilization, to avoid downtime and to increase the overall security level of a fleet of instruments.

HUMS provides, for example, information about:

- Health status
- Characteristics (device footprint)
- Operation system / security patches
- Usage of options
- Calibration and service information

Interfaces and protocols

The HUMS installation on the R&S ZND includes an SNMP agent and a REST service with HTTP endpoints. So you can access the health and usage information via LAN, using the SNMP protocol or the REST protocol. Accessing the data does not interfere with remote control via SCPI commands or with measurement execution.

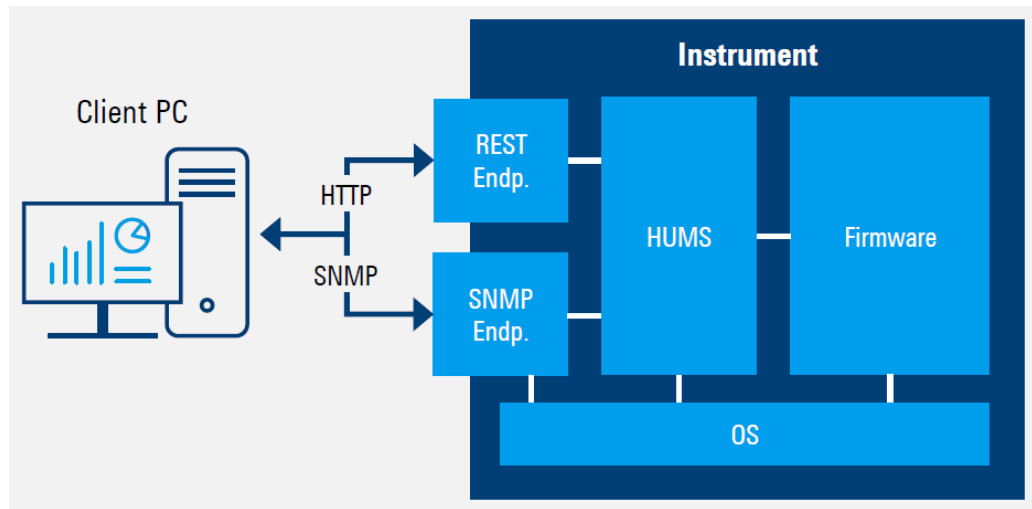

Reference information for both protocols is available on the R&S ZND at the address <http://<instrument>/api/hums/v1/documents?name=<interface>>.

For *<instrument>*, enter the hostname or the IP address of your instrument, as for access to the GUI.

For *<interface>* = *snmp*, you get a .zip file containing the MIB files for SNMP. For *<interface>* = *rest*, you get a web page with the OpenAPI specification of the REST API.

For further information about the HUMS service itself, see the R&S HUMS user manual.

5.7.13 High Output Power for R&S ZND

Option R&S ZND-B7

With hardware option R&S ZND-B7, the output power of the R&S ZND can be significantly increased:

Frequencies	Maximum Output Power	
	with R&S ZND-B7	without R&S ZND-B7
≤ 6.5 GHz	≥ 10 dBm	≥ 3 dBm
≤ 7.5 GHz	≥ 8 dBm	
≥ 6.5 GHz	≥ 6 dBm	



Hardware option R&S ZND-B7 can be retrofitted at Rohde & Schwarz service.

5.7.14 GPIB Interface

Option R&S ZND-B10

This hardware option provides a GPIB bus connector according to standard IEEE 488 / IEC 625 (GPIB). The GPIB bus interface can be used for controlling the R&S ZND from an external controller.

For interface details, refer to [Chapter 11.3.3, "GPIB Interface"](#), on page 1158.



Remote Control of External Devices via GPIB

The R&S ZND-B10 can also be used control external devices via GPIB. An additional [USB-to-IEC/IEEE Adapter](#) is only needed, if you want to control the R&S ZND via GPIB at the same time.

5.7.15 Handler I/O (Universal Interface)

Option R&S ZN-B14

A network analyzer that is equipped with a Handler I/O (Universal Interface), can interact with an external part handler. The digital control signals on the interface connector indicate the possible start and the end of a measurement, as well as a global limit check result. Typically, the handler will insert the device to be tested into a test fixture and provide a trigger pulse to initiate the measurement. After the measurement is complete, the handler will remove and replace the device and sort it into pass/fail bins. For details, refer to [Chapter 11.3.4, "Handler I/O \(Universal Interface\)"](#), on page 1161.

5.7.16 Additional Removable System Drive

Option R&S ZND-B19

Option R&S ZND-B19 provides an additional removable system drive for the R&S ZND, including operating system and VNA firmware.

See the data sheet for the available variants of this option.

5.7.17 Extended Power Range

Option R&S ZND-K7

For the R&S ZND, software option R&S ZND-K7 enables an extended power range of -45 dBm to +3 dBm.

**R&S ZND: Recalibration Required**

Although this is a software option for the R&S ZND, the instrument has to be recalibrated at Rohde & Schwarz service to comply with the specifications of the data sheet.

5.7.18 USB-to-IEC/IEEE Adapter**R&S ZVAB-B44**

Hardware option R&S ZVAB-B44 (order no. 1302.5544.03) comprises an adapter and driver software for controlling external devices via IEEE 488 / IEC 625 (GPIB). The driver software is installed on the network analyzer. Connect the USB port of the adapter to any of the master USB connectors on the front or rear panel of the analyzer. Connect the GPIB port of the adapter to the external device.

This hardware option is required, if you want to use GPIB for two purposes at the same time:

- to control the R&S ZND from an external controller (via [option R&S ZND-B10](#))
- to control external devices from the R&S ZND (via the USB2GPIB adapter)



To get the adapter to work, you have to install the NI VISA library on the R&S ZND.

5.7.19 External Power Meters

The connection of an external power meter to the R&S ZND can serve different purposes.

- Extended measurement functionality: Each external power meter represents an additional receive port. External power meters increase the number of RF input signals of a DUT that the analyzer can measure simultaneously. They can also provide accurate results for signals at inaccurate or unknown frequencies. A typical example is a mixer measurement with an unknown LO signal (and therefore unknown IF output frequency).

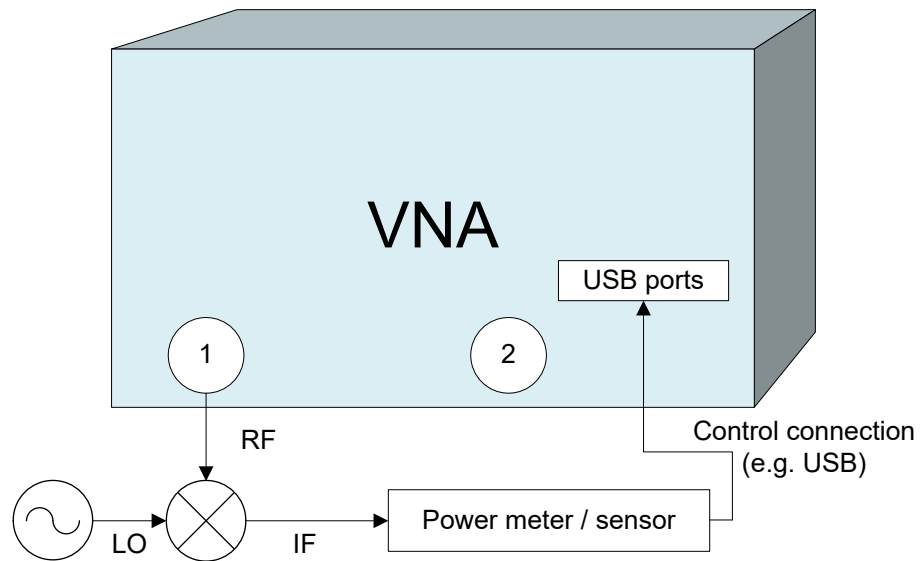

- Power calibration: An external power meter can measure the exact signal power at an arbitrary point in the test setup (reference plane) and thus provide the reference values for a power calibration. A typical example is a source power calibration for an arbitrary analyzer port.

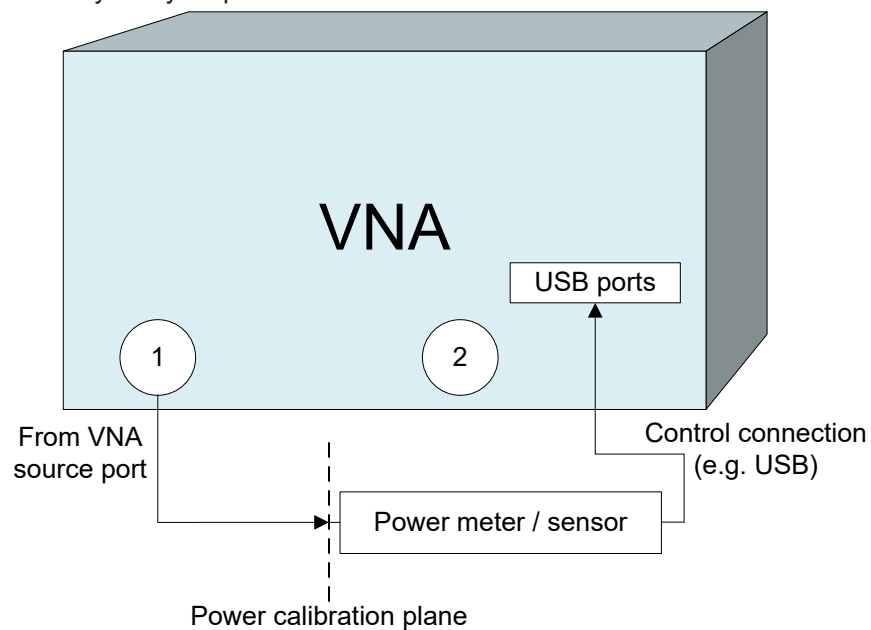

External power meters must be configured with their connection type and device address before they are available as additional receivers (SYSTEM – [SETUP] > "External Devices" > "Power Meters"). Configured power meters appear in many control elements of the R&S ZND, e.g. in the port configuration and in the power calibration dialogs.

Zeroing

Zeroing calibrates the external power meter by adjusting its reading at zero signal power. For this purpose, the RF cable between the analyzer and the power sensor must be disconnected (see tips below!). R&S power sensors and power meters automatically detect the presence of any significant input power. This aborts zeroing and generates an error message. Zeroing can take a few seconds, depending on the power meter model; refer to the documentation of your external power meter for more information.



Repeat zeroing

- During warm-up after switching on or connecting the instrument
- After a substantial change of the ambient temperature
- After fastening the power meter to an RF connector at high temperature
- After several hours of operation
- When very low-power signals are to be measured, e.g. less than 10 dB above the lower measurement limit.

A reset of the network analyzer does not affect the last zeroing result.

5.7.20 External Switch Matrices

5.7.20.1 Overview

From the perspective of the VNA, the purpose of a switch matrix is to extend the number of test ports. I.e. it converts an N-port network analyzer into an N'-port network analyzer (N'>N) without modifying the instrument itself. The increased number of test ports can reduce or even eliminate the manual reconnections of the DUT, resulting in a higher measurement speed, reliability and repeatability.

The firmware of the R&S ZND is able to control switch matrices from Rohde & Schwarz directly. In combination with an R&S ZN-Z84 it can work as a multi-port network analyzer with up to 24 ports, seamlessly performing the required matrix switching operations.



- Switch matrices require a **bidirectional** R&S ZND.
- Matrix cascading is **not** supported.

However, an N-port analyzer is always limited to measuring N signals simultaneously. I.e. even though the DUT is fully connected to the switch matrix, it may not be possible to measure all b-waves simultaneously. For example, consider a DUT with 6 unbalanced ports, connected to a 2-port analyzer via a 2x6 matrix (e.g. a R&S ZN-Z8x base unit without extensions). For each stimulus port, 5 sweeps are required to measure the resulting b-waves, $6 \cdot 5 = 30$ sweeps in total.

Furthermore, each additional sweep requires at least one matrix switching procedure. This involves command processing and physical switching and hence can take some time to complete. For mechanical switches (such as R&S ZV-Z81 variant 66), in particular, switching is quite slow and causes mechanical wear. To optimize the measurement setup w.r.t. speed and resources, the characteristics of the available switch matrices have to be accounted for.

5.7.20.2 Matrix Setup and Operation

Setting up a switch matrix at the R&S ZND firmware typically involves the following steps:

1. establish the physical connection via the appropriate management interface (USB or LAN).
2. register the matrix (as managed object).
3. define the RF configuration:
 - a) configure the matrix-VNA-connections according to the existing (or planned) physical connections between VNA test ports and matrix VNA ports.
 - b) assign the matrix test ports and the remaining VNA ports (i.e. those that are not connected to a matrix VNA port) to DUT test ports.

After this initial setup, the R&S ZND takes control of the attached matrices: it allows you to configure the test ports and dynamically establishes the required matrix routes according to the current measurement task.



To make a measurement, set up a channel where all unused logical ports are disabled.

Switch matrices are global resources: their configuration is not part of a recall set. However, a recall set will contain information about the required matrices and their RF connections. At the time the recall set is loaded, the R&S ZND checks whether the same matrix setup is still active. If not, a wizard will guide the user through the matrix configuration.

5.7.20.3 RF Connections and Matrix Connectivity

Depending on the design of the switch matrix and the RF connections between VNA and matrix

- certain matrix test ports may not be available for measurements
- certain transmission measurements may not be possible

Example:

The 4x24 extension of switch matrix R&S ZN-Z84 consists of 2 separate 2x12 submatrices, where matrix VNA ports of the "left" submatrix cannot be connected to the test ports of the "right" submatrix and vice versa. If none of the two VNA ports of a submatrix is connected, obviously no connection between the VNA and the submatrices' test ports can be established and hence reflection and transmission measurements are impossible.

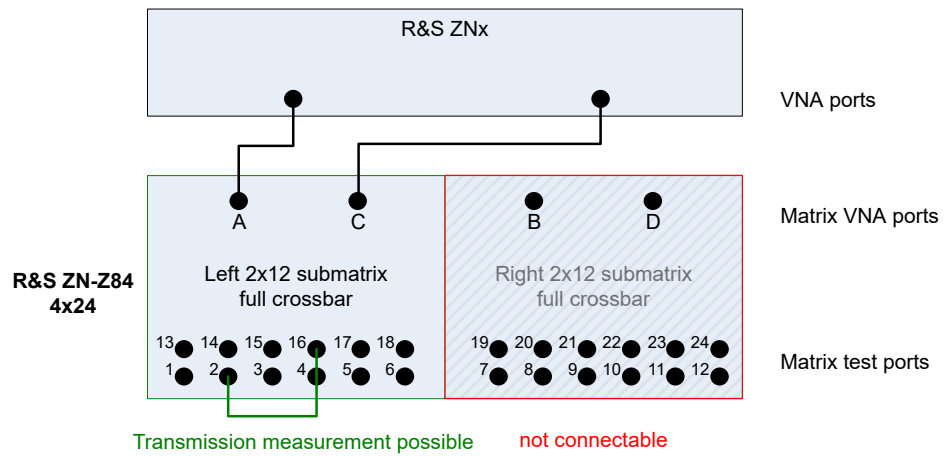

Figure 5-17: Unconnected right submatrix

With the same extension type, connecting one of two submatrix VNA ports enables reflection measurements for the corresponding matrix test ports. However, as long as a second connection between the VNA and this submatrix is missing, "intra-submatrix" transmission measurements are still impossible.

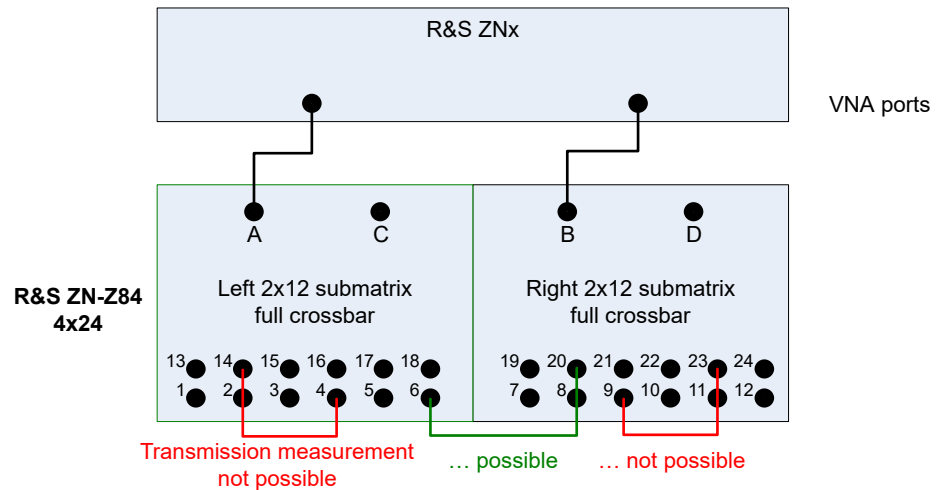

Figure 5-18: Partially connected submatrices

Basically the same argument holds true for variant 16 of switch matrix ZV-Z82, which consists of 4 separate 1x4 submatrices and that allows "inter-" but no "intra-submatrix" transmission measurements.

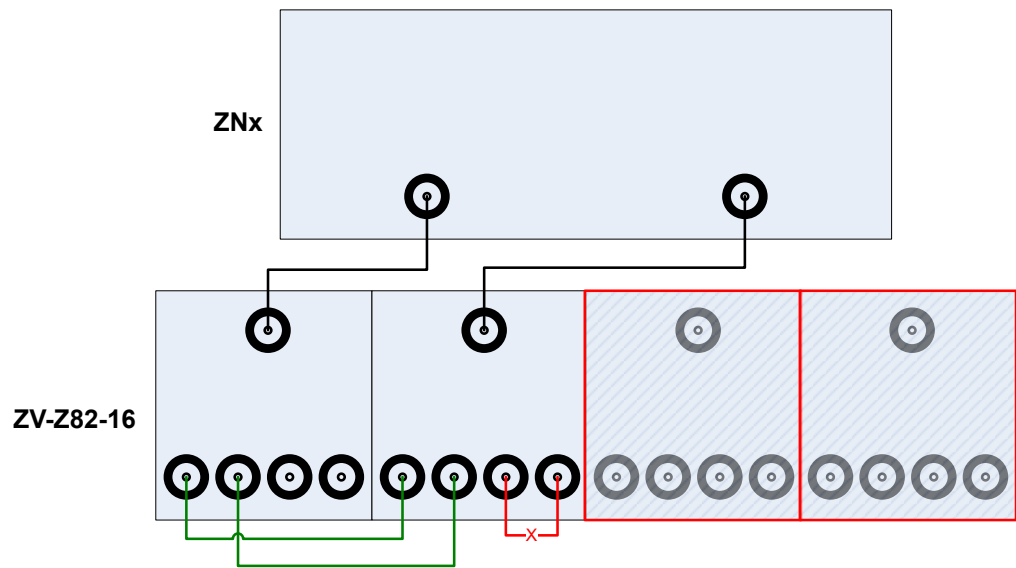

Figure 5-19: ZV-Z82-16: limited connectivity

5.7.20.4 Multiple Paths: Precision vs. Speed

A switch matrix may offer multiple routes to a given matrix test port and hence measurements may be performed using different physical paths (where a *path* consists of the traversed VNA connections and matrix routes).

These paths may have different characteristics - in particular if the corresponding matrix routes differ in the number of semiconductor or mechanical switching functions that have to be traversed.

Example:

For switch matrix ZV-Z82-09 every test port can be reached via two different routes, traversing either one or two semiconductor switches:

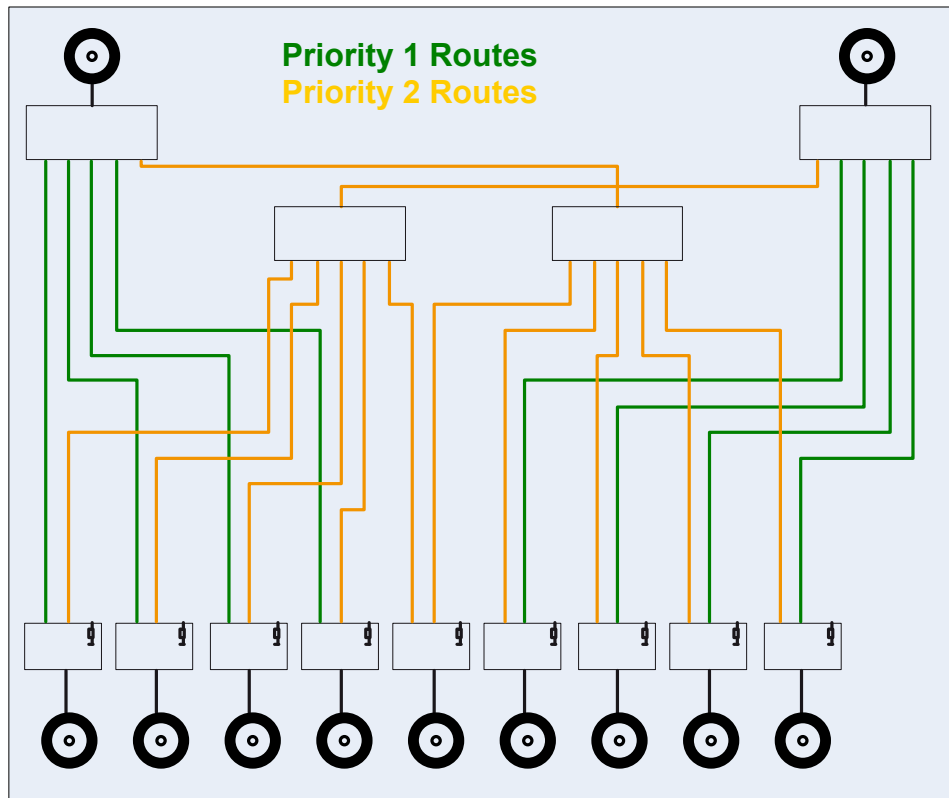

Figure 5-20: ZV-Z81 Routes and priorities

Example:

For an R&S ZN-Z8x, each route traverses exactly one of the equipped 2x6 modules. The overall route quality is determined by the number of solid state switches traversed on this 2x6 module:

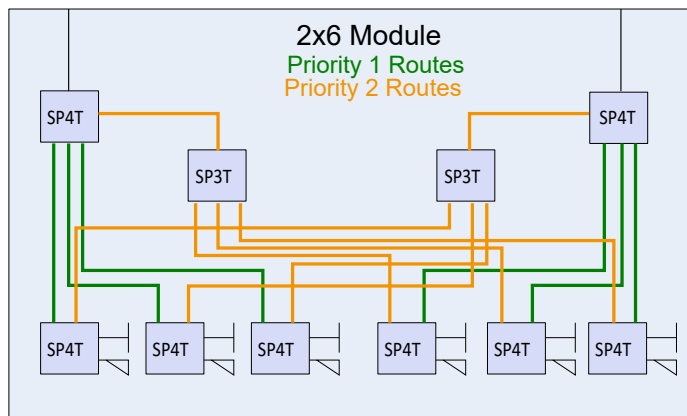

Figure 5-21: Routes and priorities



See the data sheet of the respective switch matrix for details on the available routes.

For every supported switch matrix, the available routes are prioritized according to the number of switches they traverse (the rectangles in [Figure 5-20](#)).

- To obtain highest measurement *precision*, the driving port should always use the "best possible" (highest priority) route. On the other hand this may cause additional matrix switching procedures and hence may result in a reduced measurement speed.
- If the focus is on measurement *speed*, the number of matrix switching procedures should be minimized, disregarding a possible loss in measurement precision.

The R&S ZND allows you to select which optimization should be performed.

5.7.20.5 Multiple Paths and Calibration



With switch matrices, a signal loss of up to 25 dB is possible, so (full) calibration is a must! For a high number of test ports, manual calibration is time-consuming and error-prone, so automatic calibration (with auto-detection) is recommended.

During calibration, correction data are determined for all possible paths from the VNA to the related test ports. For the currently supported matrices a maximum of 2 paths per test port are available, resulting in a maximum of

- 2 paths per reflection measurement

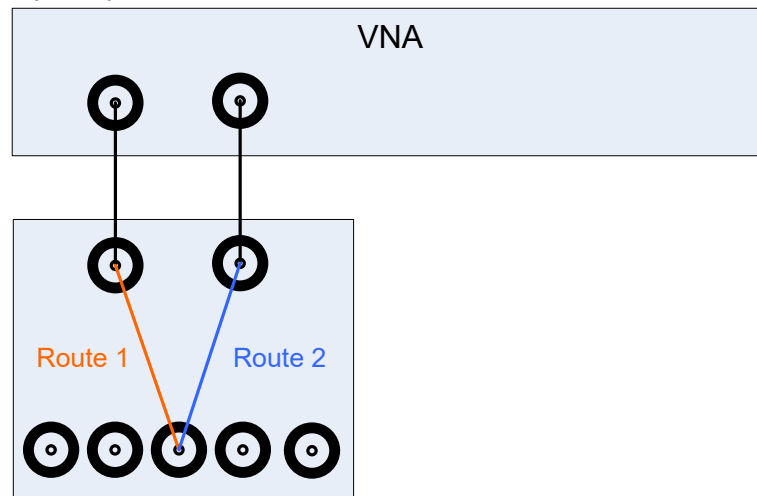

- 2 paths per transmission measurement for a 2-port VNA:

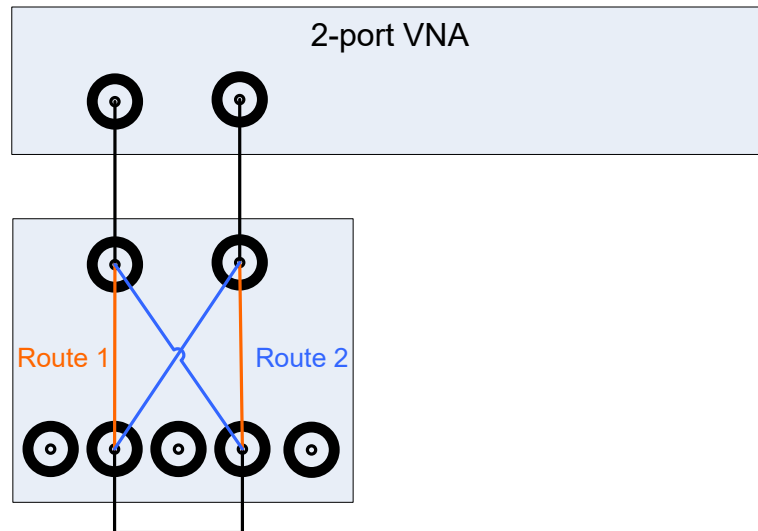

This kind of "multipath calibration" offers the following additional benefit:

During manual calibration, the measured reflection/transmission coefficients are presented as memory traces - one per path. By comparing these traces, it should be possible to track down hardware problems (cables, connectors, matrix, ...) already during calibration.

5.7.21 External DLLs

The R&S ZND firmware provides a plug-in interface that allows you to extend the VNA firmware with custom functionality (measurements, device control, ...).

The plug-in interface allows the external software to interact with the firmware before and after a change of the:

- channel
- drive port
- sweep segment
- sweep point

The plug-in then can perform arbitrary actions and eventually return data to the VNA firmware:

- as custom traces
- as input values for math functions for the calculation of other traces



To calculate a custom trace, the plug-in can make use of all data access points in the channel calculation chain. See [Chapter 5.1.5.1, "Channel Data Flow"](#), on page 77).

Furthermore, it can communicate with other processes / peripherals that are not part of the VNA firmware or host OS.

5.7.21.1 Basic Use Case

A basic use case is the integration of a power supply into an arbitrary VNA sweep.

Suppose that you want to test an amplifier with various bias settings. To do so, you can perform a CW sweep to measure S-parameters with different gate voltages applied to the amplifier at each sweep point.

With one power supply channel connected to the amplifier's gate, and another channel connected to the amplifier's drain, the measurement could proceed as follows:

1. At the beginning of the sweep, the power supply is initialized (e.g. voltage setting and current limit for each power supply channel) and then switched ON.
2. At the beginning of each sweep point, the plugin sets the power supply gate voltage to the next value.
3. At the end of each sweep point, the plugin reports the power supply reading of the gate voltage and drain current to the VNA. These readings are displayed in dedicated traces.
4. At the end of the sweep, the power supply is switched OFF.

5.7.21.2 Technology

The plug-in interface is a traditional C style DLL interface. Suitable DLLs can be compiled using different platforms, such as C or MATLAB. A plug-in is installed in the firmware as a *.zip file, containing the external DLL and, possibly, additional files to be kept with the DLL.

An SDK for external DLLs is provided with the analyzer firmware on the Rohde&Schwarz internet pages.



For details, see the HTML help topics that are distributed with the plugin SDK.

Interactions of the external DLL with analyzer firmware and external devices are synchronized with the measurement. Synchronization is done via callbacks from the FW, at so-called interrupts. At an interrupt, the measurement takes a break and waits for the FW to continue. During an interrupt, the plugin can access external devices and return results to the FW.

The VNA firmware can abort the processing in the external DLL at any time, e.g. on a [PRESET].

The DLL can handle certain trace types that must be uniquely named within the DLL. A naming scheme for traces allows the firmware (and hence the user) to request a particular trace.



If an external DLL is configured for permanent use, it performs a particular task (such as switching the state of a DUT or controlling external devices) without providing data.

5.7.21.3 Trace Calculation in the Channel Calculation Chain

To enable the calculation of trace results using data from external DLLs, a dedicated calculation step for external DLLs is inserted directly before the averaging step in the calculation chain (see [Chapter 5.1.5, "Data Flow"](#), on page 77).

This position allows maximum flexibility, because:

- The trace calculation chain is limited to one input for one output
- The position allows the plugin to use the results of the averaging step, and the trace data is calculated in the same way as for other calculation steps
- All internal measurement types can be used as input for the new calculation step



The new calculation step is only enabled if a plugin is installed (and active), and a custom trace is requested.

The new calculation step serves all active external DLLs. When custom traces are requested, the firmware asks the related DLLs which input traces they need to calculate "their" traces. During the calculation, the requested inputs are provided to the DLL, which then calculates its requested traces.

Due to its position, all internal trace types are allowed as inputs. External types are also allowed if no circular dependency is created between them.

6 GUI Reference

This chapter describes the Graphical User Interface (GUI) of the analyzer.

The most convenient way to access the GUI functions is via [Softtools](#). Hence the GUI reference is structured accordingly.

The softtools, in turn, can be opened via the keys on the front panel of the analyzer, via the on-screen [Hardkey Panel](#) or via the items in the main menu. For details, see [Chapter 6.1, "Function Keys and Softtools"](#), on page 219.

In case a GUI function can also be performed via remote control, one or more links at the end of the function description point to the related remote control commands.



For a general overview of the analyzer's capabilities and their use, refer to [Chapter 5, "Concepts and Features"](#), on page 69.

6.1 Function Keys and Softtools

Most of the [Function Keys](#) serve as "openers" for an associated softtool in the analyzer GUI.

By default, the following "opener logic" is applied:

- If the associated softtool is not displayed, pressing the hardkey
 - opens the associated softtool
 - activates its first enabled tab (default) or the last used tab (see ["Use Default Tab for Hardkey"](#) on page 523)
 - activates the first enabled input control on this tab (if any)
- If the associated softtool is already displayed, pressing the hardkey
 - activates the next enabled tab on the associated softtool (cyclically)
 - activates the first enabled input control on this tab (if any)

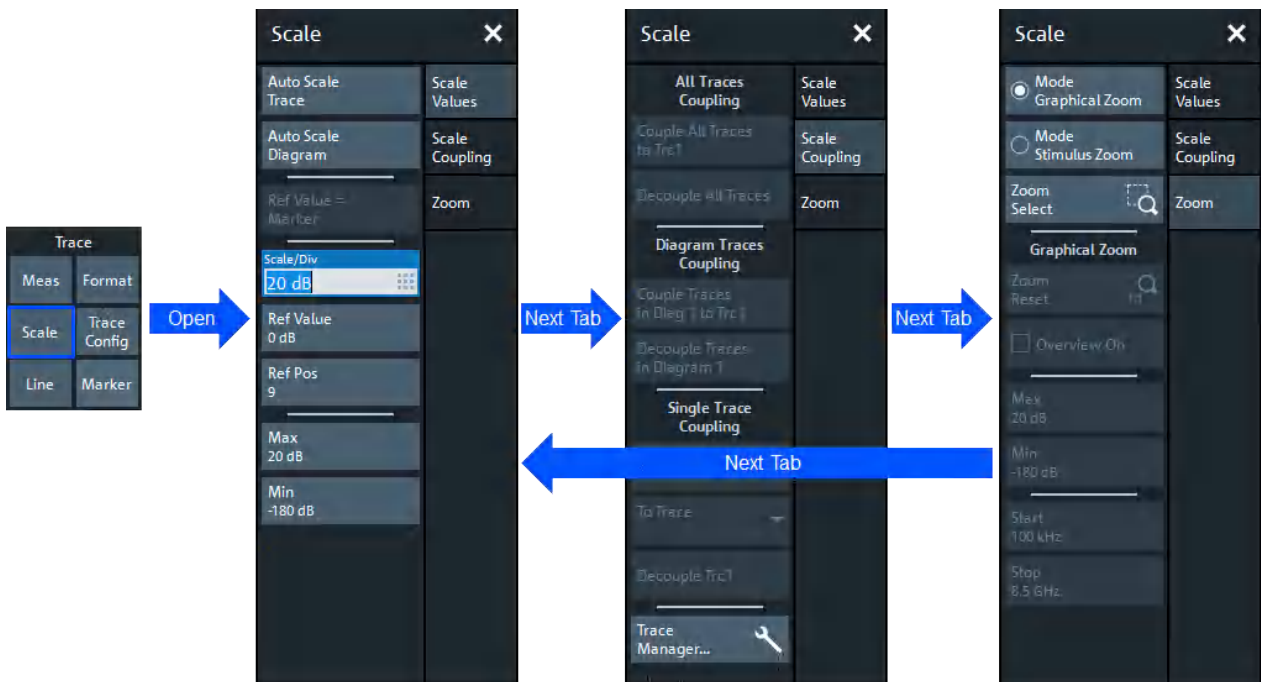

Table 6-1: Function keys and softtools

(Virtual) Hardkey	Keyboard Shortcut	Related Softtool	Action
TRACE – [MEAS]	Alt + Shift + A	Meas Softtool	default
TRACE – [FORMAT]	Alt + Shift + B	Format Softtool	default
TRACE – [SCALE]	Alt + Shift + C	Scale Softtool	default
TRACE – [TRACE CONFIG]	Alt + Shift + D	Trace Config Softtool	default
TRACE – [LINE]	Alt + Shift + E	Lines Softtool	default
TRACE – [MARKER]	Alt + Shift + G	Marker Softtool	default
STIMULUS – [START]	Alt + Shift + J	Stimulus Softtool	Selects an input field corresponding to the start, stop, center or span of the active channel's current sweep type. Activates the corresponding tab on the "Stimulus" softtool.
STIMULUS – [STOP]	Alt + Shift + K		
STIMULUS – [CENTER]	Alt + Shift + F		
STIMULUS – [SPAN]	Alt + Shift + H		
CHANNEL – [PWR BW AVG]	Alt + Shift + L	Power Bw Avg Softtool	default
CHANNEL – [SWEEP]	Alt + Shift + M	Sweep Softtool	default
CHANNEL – [CAL]	Alt + Shift + P	Cal Softtool	default
CHANNEL – [CHANNEL CONFIG]	Alt + Shift + O	Channel Config Softtool	default
CHANNEL – [TRIGGER]	Alt + Shift + R	"Trigger" softtool	opens the Trigger Tab

(Virtual) Hardkey	Keyboard Shortcut	Related Softtool	Action
CHANNEL – [OFF-SET EMBED]	Alt + Shift + Q	Offset Embed Softtool	default
SYSTEM – [FILE]	Ctrl + O	File Softtool	default
SYSTEM – [PRINT]	Ctrl + P	"File" softtool	opens the Print Tab
SYSTEM – [APPLIC]	Alt + Shift + N	Applic Softtool	default
SYSTEM – [DISPLAY]	Alt + Shift + S	Display Softtool	default
SYSTEM – [SETUP]	Alt + Shift + T	Setup Softtool	default
SYSTEM – [Windows®]	Windows key	none	n.a.
SYSTEM – [HELP]	F1	none	n.a.
SYSTEM – [PRESET]	Alt + Shift + U	none	n.a.
SYSTEM – [UNDO]	Alt + Shift + V	none	n.a.
SYSTEM – [REDO]	Alt + Shift + I	none	n.a.

6.2 Meas Softtool

The "Meas" softtool allows you to select the quantities to be measured and displayed.

Access: TRACE – [MEAS]



Background information

For a detailed description of all measurement results of the R&S ZND, refer to [Chapter 5.3, "Measurement Results"](#), on page 103.



Efficient trace handling

To select a result and display it as a trace, you can simply drag and drop the corresponding button into a diagram area. See also [Chapter 4.3.4, "Handling Diagrams, Traces, and Markers"](#), on page 47.

Port activation on demand

If a requested result involves disabled ports, but could be calculated if those ports were configured as single-ended ports with "logical port number = physical port number", then the required logical port configuration is performed automatically.

For example, with P1 assigned to L1 and P2 disabled, S21 could be measured if P2 would be assigned to L2.

6.2.1 S-Params Tab

Selects S-parameters as measured quantities. S-parameters are the basic measured quantities of a network analyzer. They describe how the DUT modifies a signal that is transmitted or reflected in forward or reverse direction. S-parameters (and derived quantities such as Y- and Z-parameters) fully characterize a linear DUT.



Background information

Refer to [Chapter 5.3.1, "S-Parameters"](#), on page 104.

6.2.1.1 Controls on the S-Params Tab

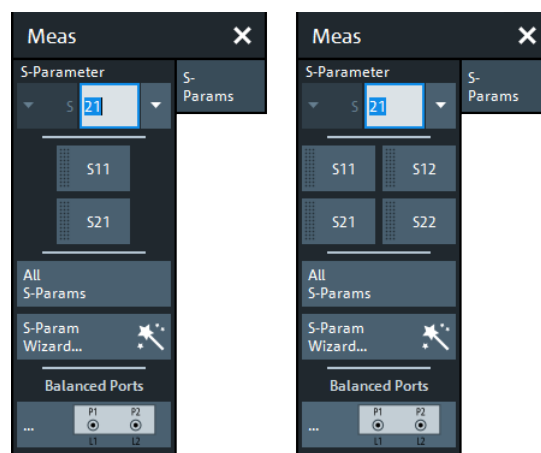

left = unidirectional R&S ZND
right = bidirectional R&S ZND

S-Parameter (selector)

Selects an [S-parameters](#) as a measured quantity for the active trace.

Single-ended (unbalanced) S-parameters are referred to as $S_{\langle out \rangle \langle in \rangle}$, where $\langle out \rangle$ and $\langle in \rangle$ denote the output and input **logical** port numbers, respectively.

If entered manually, $\langle out \rangle$ and $\langle in \rangle$ must be expressed using the same number of digits. I.e. for $\langle out \rangle=10$ and $\langle in \rangle=9$ you can specify $S_{\langle out \rangle \langle in \rangle}$ as S_{1009} or S_{010009} , but not as S_{109} . For a channel setup with n single-ended ports, n^2 single-ended S-parameters can be measured.

In presence of balanced ports, standard S-parameters are defined in the form $S_{\langle m_out \rangle \langle m_in \rangle \langle out \rangle \langle in \rangle}$, where output mode $\langle m_out \rangle$ and input mode $\langle m_in \rangle$ can be one of:

- d (differential, balanced)
- c (common, balanced)
- s (single-ended, unbalanced)

It is also possible to display "raw" single-ended S-parameters within the same channel: after setting the S-Parameter type to "S" any pair of (used) **physical** ports can be selected.

Note: For a unidirectional R&S ZND (see [Chapter 5.1.4.3, "R&S ZND: Unidirectional vs. Bidirectional Operation"](#), on page 75) the reverse direction cannot be measured. Hence S_{12} , S_{22} and balanced measurements are not available.

Remote command:

```
CALCulate<Ch>:PARAmeter:MEASure
CALCulate<Ch>:PARAmeter:MEASure:SENDEd
CALCulate<Ch>:PARAmeter:SDEFine
CALCulate<Ch>:PARAmeter:SDEFine:SENDEd
```

S<out><in>

Selects one of the four elements of the standard 2-port [S-parameters](#) as a measured quantity for the active trace.

Note: For a unidirectional R&S ZND (see [Chapter 5.1.4.3, "R&S ZND: Unidirectional vs. Bidirectional Operation"](#), on page 75) the reverse direction (S_{12} , S_{22}) cannot be measured.

Remote command:

```
CALCulate<Ch>:PARAmeter:MEASure "<Trace_Name>", "S11" | "S12" |
"S21" | "S22"
CALCulate<Ch>:PARAmeter:SDEFine "<Trace_Name>", "S11" | "S12" |
"S21" | "S22"
```

All S-Params

Creates 4 diagrams and displays the full set of [S-Parameters](#), one in each diagram. The diagrams are arranged as an (2 x 2) matrix.

The reflection coefficients S_{ii} appear in the diagrams on the main diagonal, the transmission coefficients S_{ij} ($i \neq j$) occupy the other diagrams. By default, reflection coefficients are displayed in Smith diagrams; transmission coefficients in Cartesian diagrams "dB Mag" scale.

See also [Format Softtool](#).

Note: For a unidirectional R&S ZND (see [Chapter 5.1.4.3, "R&S ZND: Unidirectional vs. Bidirectional Operation"](#), on page 75) "All S-Params" is limited to S_{11} and S_{21} , whose diagrams are presented one beneath the other.

Remote command:

```
CALCulate<Ch>:PARAmeter:SDEFine
CALCulate<Ch>:PARAmeter:DEFine:SGRoup
```

S-Param Wizard...

Opens a dialog that guides you through the setup of a standard multi-port S-parameter measurement in a frequency sweep. See [Chapter 6.2.1.2, "S-Parameter Wizard"](#), on page 224.

Dialog and opener button are not available if a switch matrix is configured.

Balanced Ports...

Opens a dialog that allows you to enable/disable physical ports and to define logical ports (balanced or unbalanced) in the active channel. See [Chapter 6.2.1.3, "Balanced Ports Dialog"](#), on page 226.

Note: If the "Fixture Simulator" is disabled for the related channel (see "[Fixture Simulator](#)" on page 429), the "Balanced Ports..." button is inactive (grayed out).

6.2.1.2 S-Parameter Wizard

The "S-Parameter Wizard" guides you through the setup of a standard two-port S-parameter measurement in a frequency sweep.



This dialog is not available if a switch matrix is configured.

Access: TRACE – [MEAS] > "S-Params" > "S-Param Wizard..."

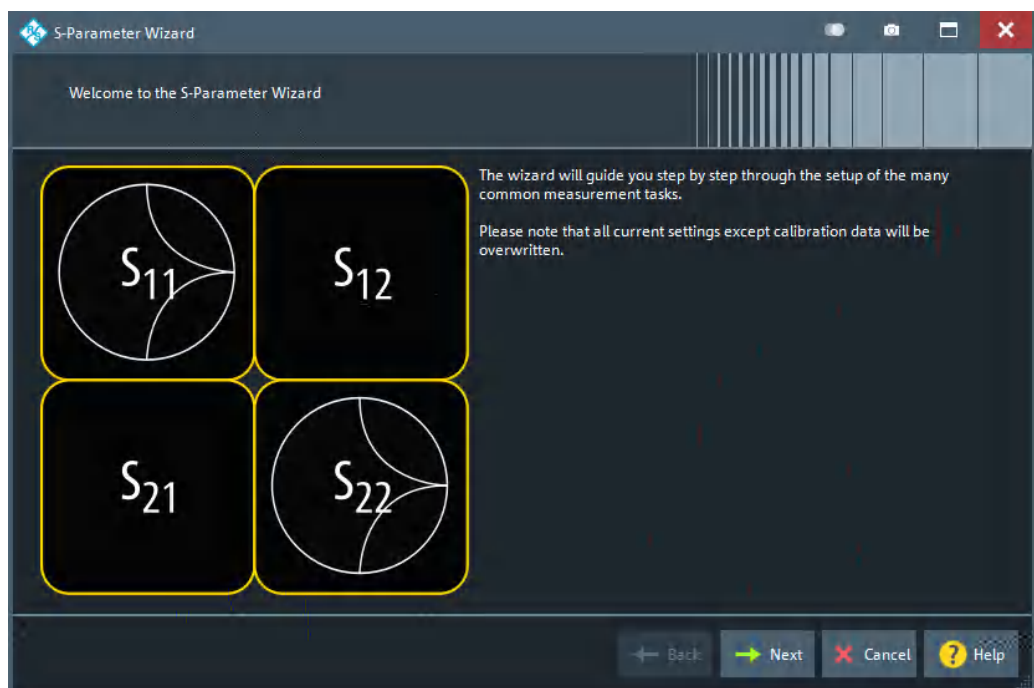

The wizard proceeds in the following steps:

1. **Select the test setup.**

Choose the port setup of the analyzer according to the port configuration of your DUT. Then connect the DUT to the selected analyzer ports.

This step corresponds to the "Predefined Config" tab of the "Balanced Ports" dialog; see "[Predefined Config Tab](#)" on page 226.

2. **Define the port impedances.**

Assign reference impedances to all physical and balanced test ports selected in the previous step. The reference impedances can be complex.

This step corresponds to the "Reference Impedance" tab of the "Balanced Ports" dialog; see "[Reference Impedance Tab](#)" on page 229.

Tip: The default reference impedance of the physical analyzer ports is $Z_0 = 50 \Omega$. The default reference impedances for balanced ports are derived hereof. You do

not need to change this value unless you want to renormalize the port impedances; see [Chapter 5.3.2, "Reference Impedances"](#), on page 105.

Note: For a unidirectional R&S ZND (see [Chapter 5.1.4.3, "R&S ZND: Unidirectional vs. Bidirectional Operation"](#), on page 75) balanced measurements are not supported.

3. **Select the measurement parameters and the diagram areas.**

Depending on the test setup selected in [step 1](#), the wizard offers different sets of S-parameters. Each S-parameter trace is displayed in a separate diagram. For transmission parameters, the wizard always selects dB magnitude format. For reflection parameters, you can select between Smith or dB magnitude format.

Tip: You can always use the "Back" button to return to previous wizard steps and modify your settings.

4. **Select the sweep settings.**

Lets you choose the [frequency range](#), and the [number of points](#) per sweep.

5. **Select the measurement bandwidth and source power.**

Choose a typical [measurement bandwidth](#) and one of three typical [source power](#) values. A smaller measurement bandwidth increases the dynamic range but slows down the measurement. If necessary, select a smaller source power to protect the input port of the analyzer.

Note:

The predefined bandwidths and source powers have been selected according to the following criteria:

- The large measurement bandwidth ("Fast Sweep") ensures that the noise of an S_{21} trace at minimum source power and 0 dB attenuation is smaller than 0.1 dB.
- The default source power for a passive DUT ensures that the analyzer receiver is in its linear range (no compression) if a passive DUT with 0 dB attenuation is measured. The default source powers for active DUTs ensure no compression if an active DUT with 20 dB or 40 dB gain is measured.
If the actual gain of the DUT is higher than 50 dB, then the default source power of -40 dB is still too high. It must be changed after finishing the wizard.

6. **Perform a calibration (optional).**

Allows you to perform a calibration. For a bidirectional instrument, the "S-Parameter Wizard" proposes a full two-port calibration; automatic calibration is also possible (if a calibration unit is available). For a unidirectional instrument, the default calibration type is a one path two ports calibration; automatic calibration is not possible.

Tip:

You can skip the calibration step (select "Finish now without Calibration") if one of the following applies:

- A valid calibration is already assigned to the active channel
- You want to apply a valid calibration stored in the cal pool.
- You do not want to use a calibration, e.g. because the factory calibration is accurate enough for your measurement.



Instrument reset

To obtain a predictable result, the measurement wizard has to reset all settings except the current calibration data. Store your recall set if you do not want to lose the current configuration.

6.2.1.3 Balanced Ports Dialog

The "Balanced Ports" dialog allows you to enable/disable physical ports and to define logical ports (balanced or unbalanced) in the active channel.

Access: CHANNEL – [CHANNEL CONFIG] > "Port Config" > "Balanced Ports..."



Background information

Refer to the following sections:

- [Chapter 5.3.6, "Unbalance-Balance Conversion"](#), on page 115
- [Chapter 5.3.6.1, "Balanced Port Configurations"](#), on page 116
- [Chapter 5.3.2, "Reference Impedances"](#), on page 105

Predefined Config Tab

The "Predefined Config" tab of the "Balanced Ports" dialog provides the most commonly used logical port configurations of the analyzer.



This tab is hidden if a switch matrix is configured.

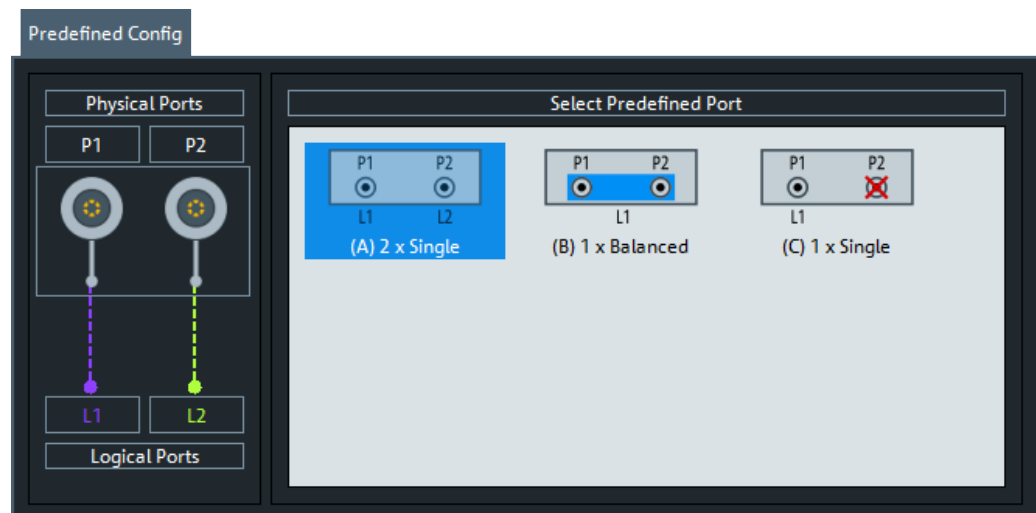

The port configurations are arranged in the list to the right. The resulting port assignment is shown on the left-hand side of the "Predefined Config" tab.

- For a single-ended port, the diagram shows a single line between the physical test port and the logical port.

- For a balanced port, two physical ports are combined to form a single logical port.
- For unused ports, the physical port is crossed out; no logical port number is assigned.



For a unidirectional R&S ZND (see [Chapter 5.1.4.3, "R&S ZND: Unidirectional vs. Bidirectional Operation"](#), on page 75) the balanced port scenario (B) is not available.

Select Predefined Port

Allows you to select from a set of predefined logical port configurations.

For a bidirectional R&S ZND, three configurations are possible: two single-ended ports, one balanced port, only port 1 in use (single-ended reflection measurement). For a unidirectional R&S ZND (see [Chapter 5.1.4.3, "R&S ZND: Unidirectional vs. Bidirectional Operation"](#), on page 75), the balanced port configuration is not available.

Remote command:

```
SOURce<Ch>:LPORT<LogPt>
```

```
SOURce<Ch>:LPORT<LogPt>:CLEar
```

Logical Port Config Tab

The "Logical Port Config" tab of the "Balanced Ports" dialog allows you to configure logical ports (balanced or unbalanced) and to disable unused physical ports in the active channel.



This tab is only visible if a switch matrix is configured).

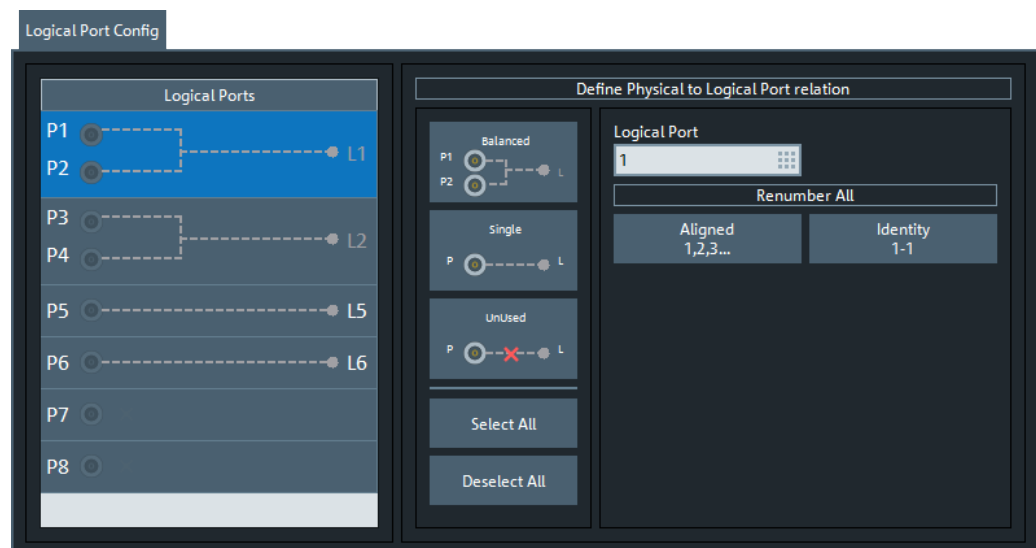

Define Physical to Logical Port Relation

Allows you to define balanced, single-ended, and unused ports and provides functions for (re)numbering the resulting logical ports.

In principle, it is possible to combine any pair of two physical analyzer ports into a balanced port. With n test ports a maximum of $n/2$ (n even) or $(n - 1)/2$ (n odd) logical ports is supported.

- To define a balanced port, select two physical ports and tap "Balanced".
- To dissolve balanced ports, select them and tap "Single".
- To exclude logical ports from the measurement, select them and tap "Unused".
- To assign a number to a logical port, select it and enter a new "Logical Port" number in the corresponding field
- To number the logical ports in line with the physical ports, select "Identity 1-1"
For balanced ports, the lower of the two physical port numbers is selected.
- To number the logical ports consecutively from top to bottom, select "Aligned 1,2,3..."

Remote command:

```
SOURce<Ch>:LPORt<LogPt>
```

```
SOURce<Ch>:LPORt<LogPt>:CLEAr
```

User Config Tab

The "User Config" tab of the "Balanced Ports" dialog defines a new balanced port configuration.



For a unidirectional R&S ZND (see [Chapter 5.1.4.3, "R&S ZND: Unidirectional vs. Bidirectional Operation"](#), on page 75) this tab is not available.



If more a switch matrix is configured, this tab is replaced by the [Logical Port Config Tab](#) tab.

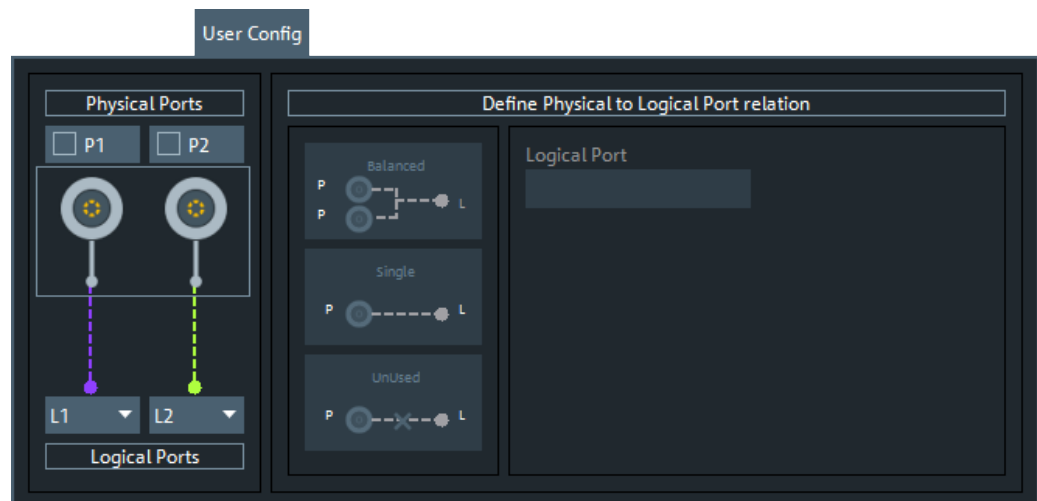

Physical Ports / Logical Ports

Allows you to renumber logical ports.

Remote command:

```
SOURce<Ch>:LPORt<LogPt>
```

```
SOURce<Ch>:LPORt<LogPt>:CLEAr
```

Define Physical to Logical Port Relation

Allows you to define balanced, single-ended, and unused ports. The two physical ports of the analyzer can be combined into a balanced port.

- To define a balanced port, select two physical ports and tap "Balanced".
- To dissolve a balanced port, select it and tap "Single".
- To exclude a physical port from the measurement, select the port and tap "Unused".

Furthermore, provides functions for renumbering the logical ports.

Remote command:

```
SOURce<Ch>:LPORt<LogPt>
```

```
SOURce<Ch>:LPORt<LogPt>:CLEAr
```

Reference Impedance Tab

The "Reference Impedance" tab of the "Balanced Ports" dialog allows you to define (or redefine) the impedances of the logical ports.



Background information

Refer to [Chapter 5.3.2, "Reference Impedances"](#), on page 105.

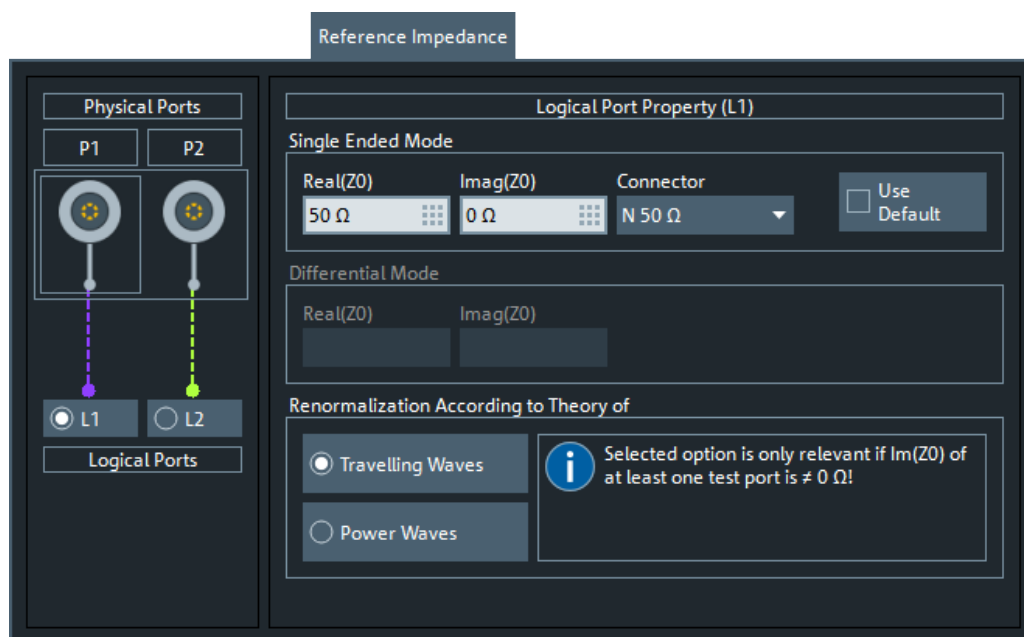

By default, the reference impedance of a physical port is set to the reference impedance of the connector type assigned to the port. However, it can be defined as an arbitrary complex value (renormalization of port impedances). By changing the reference impedance, it is possible to convert the measured values at 50 Ω (75 Ω) into values at arbitrary port impedances.

For balanced ports, it is possible to define separate complex reference impedances for differential and for common mode.

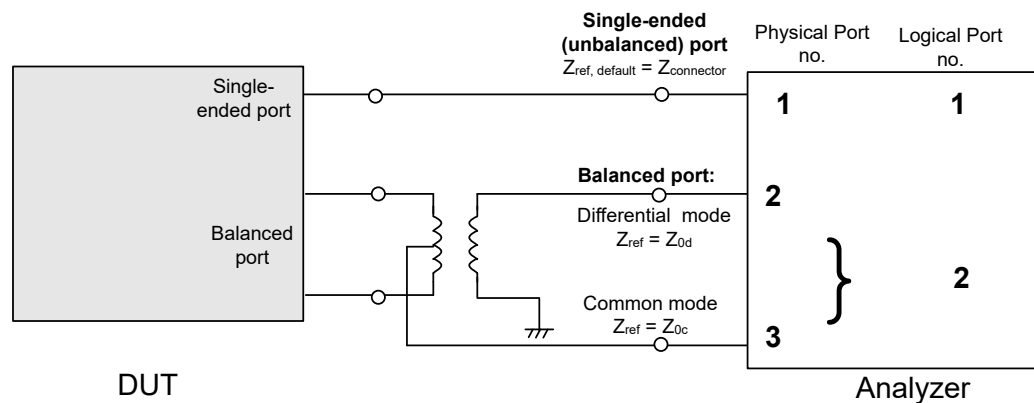

For a unidirectional R&S ZND (see [Chapter 5.1.4.3, "R&S ZND: Unidirectional vs. Bidirectional Operation"](#), on page 75) balanced measurements are not available.

Single Ended Mode / Common Mode / Differential Mode

Defines arbitrary reference impedances.

"Single Ended Mode" is available for single-ended logical ports only, "Common Mode" and "Differential Mode" impedances for balanced ports only.

The default values for the balanced port reference impedances are derived from the (real) default reference impedance $Z_0 = 50 \Omega$ of the (single-ended) physical analyzer ports:

- The default value for the differential mode is $Z_{0d} = 100 \Omega = 2 \cdot Z_0$.
- The default value for the common mode is $Z_{0c} = 25 \Omega = Z_0/2$.

Note: For a unidirectional R&S ZND (see [Chapter 5.1.4.3, "R&S ZND: Unidirectional vs. Bidirectional Operation"](#), on page 75) only single ended mode is available.

Remote command:

```
[SENSe<Ch>:] PORT<PhyPt>:ZREFerence
[SENSe<Ch>:] LPORt<LogPt>:ZCOMmon
[SENSe<Ch>:] LPORt<LogPt>:ZDIFferent
```

Connector

Allows you to specify the connector type of the related physical port.

Remote command:

```
[SENSe<Ch>:] CORRection:COLLect:CONNectiOn<PhyPt>
```

Use Default

Allows you to toggle between default and renormalized port impedance (or impedances) for the selected logical port and connector type.

Remote command:

```
[SENSe<Ch>:] LPORt<LogPt>:ZDEFault[:STATe]
```

Renormalization According to Theory of

Selects the waveguide circuit theory for renormalization. The conversion formulas of these theories only differ if the reference impedance of at least one test port has a non-zero imaginary part.

Refer to [Chapter 5.3.2, "Reference Impedances"](#), on page 105.

Remote command:

`CALCulate<Chn>:TRANSform:IMPedance:RNORmal`

6.2.2 Ratios Tab

Selects ratios of wave quantities as measured quantities.



Background information

Refer to [Chapter 5.3.5, "Wave Quantities and Ratios"](#), on page 112.

6.2.2.1 Controls on the Ratios Tab

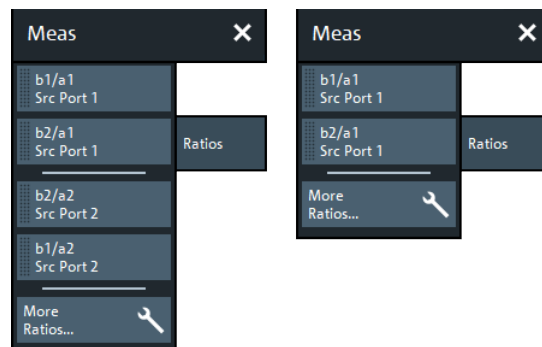

left = bidirectional R&S ZND

right = unidirectional R&S ZND

The "More Ratios..." button opens the [More Ratios](#) dialog which allows to select an arbitrary [ratio](#) of wave quantities.

b<i> / a<j> Source Port <j>

Selects predefined complex [ratios](#) of the standard 2-port wave quantities a_1 , a_2 , b_1 , and b_2 .

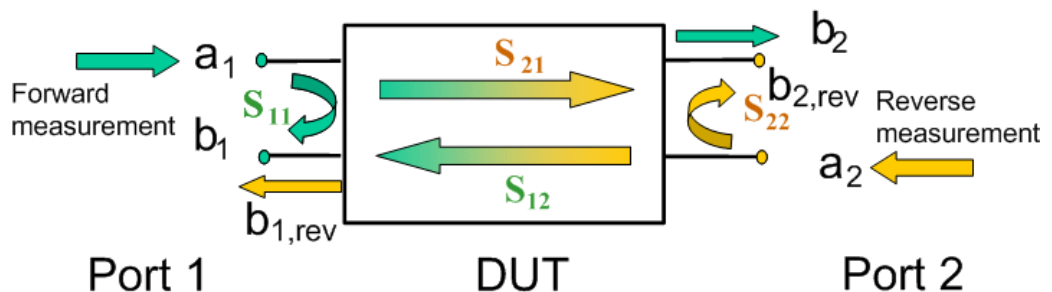

The predefined wave quantities can all be obtained with the same test setup, where a 2-port DUT is connected between the analyzer ports 1 and 2. The stimulus signal is provided by the analyzer port 1 or 2 ("Source Port").

The predefined wave quantities correspond to the 2-port S-parameters:

- "b1/a1 Source Port 1" is the ratio of the wave quantities b_1 and a_1 , measured at port 1. This ratio corresponds to the S-parameter S_{11} (input reflection coefficient).
- "b2/a1 Source Port 1" is the ratio of the wave quantities b_2 and a_1 and corresponds to the S-parameter S_{21} (forward transmission coefficient).
- "b2/a2 Source Port 2" is the ratio of the wave quantities b_2 and a_2 , measured at port 2. This ratio corresponds to the S-parameter S_{22} (output reflection coefficient).
- "b1/a2 Source Port 2" is the ratio of the wave quantities b_1 and a_2 and corresponds to the S-parameter S_{12} (reverse transmission coefficient).

The analyzer can also measure arbitrary ratios for other source ports; see [Chapter 6.2.2.2, "More Ratios Dialog"](#), on page 232.

Tip: In the trace list, the source port is indicated in brackets. "b2/a1(P1)" denotes the ratio b_2/a_1 with source port 1.

Note: For a unidirectional R&S ZND (see [Chapter 5.1.4.3, "R&S ZND: Unidirectional vs. Bidirectional Operation"](#), on page 75) ratios for source port 2 are not available.

Remote command:

```
CALCulate<Ch>:PARAmeter:MEASure "<Trace_Name>", "B2/A1" | ...
CALCulate<Ch>:PARAmeter:SDEFine "<Trace_Name>", "B2/A1" | ...
```

6.2.2.2 More Ratios Dialog

The More Ratios dialog allows you to select arbitrary ratios between wave quantities b_i , a_j as measured quantity. The ratios can be calculated with arbitrary source port and different detector settings.

Access: TRACE – [MEAS] > "Ratios" > "More Ratios..."



Background information

Refer to the following sections:

- [Chapter 5.3.5.1, "Wave Quantities"](#), on page 112
- [Chapter 5.3.5.2, "Ratios"](#), on page 113

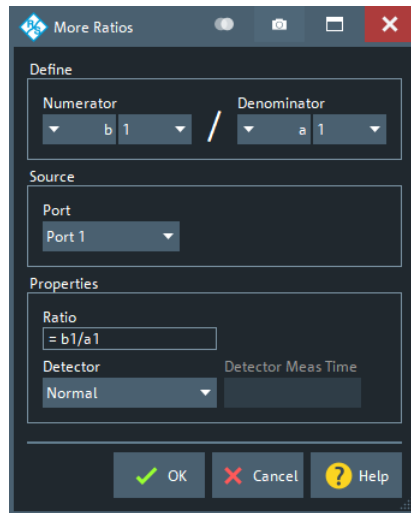

For a unidirectional R&S ZND (see [Chapter 5.1.4.3, "R&S ZND: Unidirectional vs. Bidirectional Operation"](#), on page 75) only port 1 may serve as source and hence the corresponding control is disabled.

The notation for ratios follows the usual scheme of the vector network analyzer:

- The a-waves are the outgoing/transmitted waves at the analyzer's test ports.
- The b-waves are the incoming/measured waves.
- The source port for the stimulus signal must be specified in addition.
- The port number range covers all test ports of the analyzer.

Numerator

Selects the type (left pull-down list) and the port number assignment (right pull-down list) of the wave that forms the numerator of the [ratio](#).

Remote command:

```
CALCulate<Ch>:PARAmeter:MEASure "<Trace_Name>", "B2/A1" | ...
CALCulate<Ch>:PARAmeter:SDEFine "<Trace_Name>", "B2/A1" | ...
```

Denominator

Selects the type (left pull-down list) and the port number assignment (right pull-down list) of the wave that forms the denominator of the [ratio](#).

Remote command:

```
CALCulate<Ch>:PARAmeter:MEASure "<Trace_Name>", "B2/A1" | ...
CALCulate<Ch>:PARAmeter:SDEFine "<Trace_Name>", "B2/A1" | ...
```

Port

The source port for the stimulus signal: "Port 1" or "Port 2" for a bidirectional R&S ZND. For a unidirectional R&S ZND (see [Chapter 5.1.4.3, "R&S ZND: Unidirectional vs. Bidirectional Operation"](#), on page 75) only port 1 may serve as source and hence this control is disabled.

Remote command:

```
CALCulate<Ch>:PARAmeter:MEASure "<Trace_Name>", "<Ratio>"
```

```
CALCulate<Ch>:PARAmeter:SDEFine "<Trace_Name>", "<Ratio>"
```

Detector

Selects the algorithm that is used to calculate the results points from the raw measurement data.

For details refer to [Chapter 5.3.5.3, "Detector Settings"](#), on page 114.

Remote command:

```
CALCulate<Ch>:PARAmeter:MEASure
```

```
CALCulate<Ch>:PARAmeter:SDEFine
```

```
[SENSE<Ch>:]SWEep:DETECTOR:TIME
```

6.2.3 Wave Tab

Selects wave quantities as measured quantities.



Background information

Refer to [Chapter 5.3.5, "Wave Quantities and Ratios"](#), on page 112.

6.2.3.1 Controls on the Wave Tab

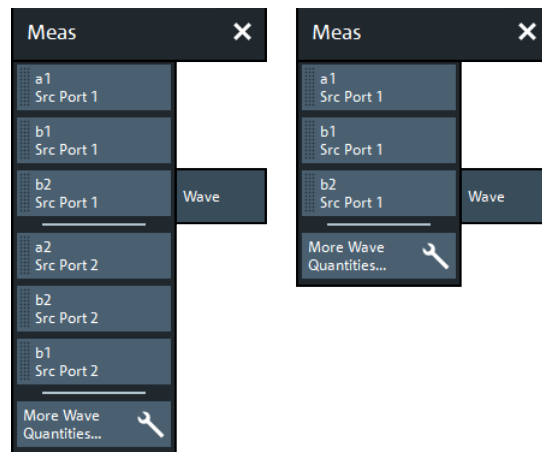

left = bidirectional R&S ZND

right = unidirectional R&S ZND

The "More Wave Quantities..." button opens the [More Wave Quantities](#) dialog which allows to select an arbitrary [wave quantity](#), e.g. for different source ports or higher port numbers.

a<i> Source Port <i>, **b<j>** Source Port <j>

Selects one of the standard 2-port [wave quantities](#) a_i , b_j for different source ports.

The predefined wave quantities are obtained with different source ports. "a1 Source Port 1", "b1 Source Port 1" and "b1 Source Port 2" are measured at Port 1 of the analyzer. "a2 Source Port 2, b2 Source Port 1" and "b2 Source Port 2" are measured at Port 2 of the analyzer.

- "a1 Source Port 1" is the wave transmitted at physical port 1. In a standard S-parameter measurement, this wave is fed to the input port (port 1) of the DUT (forward measurement).
- "b1 Source Port 1" is the wave received at physical port 1. In a standard S-parameter measurement, this wave is reflected at port 1 of the DUT (forward measurement).
- "b2 Source Port 1" is the wave received at physical port 2. In a standard S-parameter measurement, this wave is transmitted at port 2 of the DUT (forward measurement).
- "a2 Source Port 2" is the wave transmitted at physical port 2. In a standard S-parameter measurement, this wave is fed to the output port (port 2) of the DUT (reverse measurement).
- "b1 Source Port 2" is the wave received at physical port 1. In a standard S-parameter measurement, this wave is transmitted at port 2 of the DUT (reverse measurement).
- "b2 Source Port 2" is the wave received at physical port 2. In a standard S-parameter measurement, this wave is fed to the output port (port 2) of the DUT (reverse measurement).

Tip: In the trace list, the source port is indicated in brackets. For example, "a1(P1)" denotes the wave a_1 with source port 1.

The analyzer can also measure arbitrary wave quantities for other source ports; see [Chapter 6.2.3.2, "More Wave Quantities Dialog"](#), on page 235.

Note: For a unidirectional R&S ZND (see [Chapter 5.1.4.3, "R&S ZND: Unidirectional vs. Bidirectional Operation"](#), on page 75) wave quantities for source port 2 are not available.

Remote command:

```
CALCulate<Ch>:PARAMeter:MEASure "<Trace_Name>", "A1" | ...
CALCulate<Ch>:PARAMeter:SDEFine "<Trace_Name>", "A1" | ...
```

6.2.3.2 More Wave Quantities Dialog

The "More Wave Quantities" dialog provides arbitrary wave quantities with arbitrary source ports as measured quantities. All wave quantities can be calculated with different detector settings.

Access: TRACE – [MEAS] > "Wave" > "More Wave Quantities..."



Background information

Refer to the following sections:

- [Chapter 5.3.5.1, "Wave Quantities"](#), on page 112
- [Chapter 5.3.5.2, "Ratios"](#), on page 113

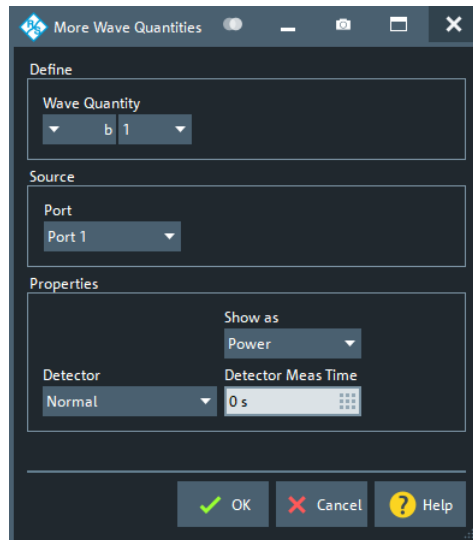

The notation for wave quantities follows the usual scheme of the vector network analyzer:

- The a-waves are the outgoing/transmitted waves at the analyzer's test ports.
- The b-waves are the incoming/measured waves.
- The source port for the stimulus signal must be specified in addition.
- The port number range covers all test ports of the analyzer.

Wave Quantity

Selects the type (left pull-down list) and the port number assignment (right pull-down list) of the [wave quantity](#).

Remote command:

```
CALCulate<Ch>:PARAmeter:MEASure "<Trace_Name>", "A1" ...
```

```
CALCulate<Ch>:PARAmeter:SDEFine "<Trace_Name>", "A1" ...
```

Source > Port

The source port for the stimulus signal: "Port 1" or "Port 2" for a bidirectional R&S ZND. For a unidirectional R&S ZND (see [Chapter 5.1.4.3, "R&S ZND: Unidirectional vs. Bidirectional Operation"](#), on page 75) only port 1 may serve as source and hence this control is disabled.

The analyzer places no restriction on the combination of source ports and port numbers of the measured wave quantity. For example, it is possible to measure a_2 while port 1 is the source port (e.g. to estimate the directivity of the internal test set's directional element).

Remote command:

```
CALCulate<Ch>:PARAmeter:MEASure "<Trace_Name>", "A1" ...
```

```
CALCulate<Ch>:PARAmeter:SDEFine "<Trace_Name>", "A1" ...
```

Show as

Selects the physical unit of the displayed trace. It is possible to display the measured "Voltage" V or to convert it into a power value P according to the formula

$$P = V^2 / \text{Re}(Z_0).$$

Z_0 denotes the reference impedance of the source port (for wave quantities a_n) or of the receive port (for wave quantities b_n). The reference impedances are defined in the "Balanced Ports" dialog; see [Chapter 6.2.1.3, "Balanced Ports Dialog"](#), on page 226.

Remote command:

```
CALCulate<Chn>:FORMat:WQUType
```

Detector

Selects the algorithm that is used to calculate the results points from the raw measurement data.

For details refer to [Chapter 5.3.5.3, "Detector Settings"](#), on page 114.

Remote command:

```
CALCulate<Ch>:PARAmeter:MEASure
CALCulate<Ch>:PARAmeter:SDEFine
[SENSe<Ch>:]SWEep:DETEctor:TIME
```

6.2.4 Z←Sij Tab

Selects converted impedances as measured quantities. The impedances are calculated from the measured S-parameters.



Background information

Refer to the following sections:

- [Chapter 5.3.3, "Impedance Parameters"](#), on page 107
- [Chapter 5.3.3.1, "Converted Impedances"](#), on page 107

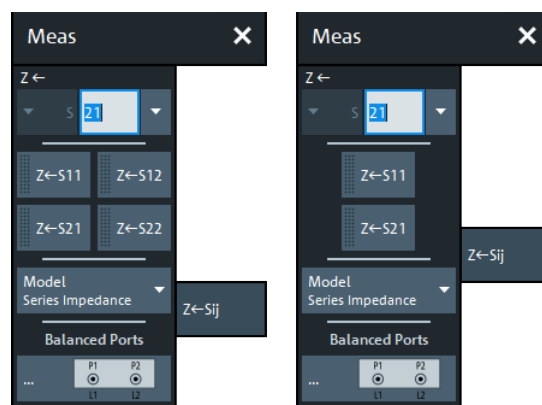

left = bidirectional R&S ZND

right = unidirectional R&S ZND

Z←S<out><in> selector

Selects a [converted impedance](#) parameter as a measured quantity for the active trace. For an n-port vector network analyzer, the pull-down list provides the full set of n^2 impedance parameters.

Converted impedance parameters are expressed as $Z_{\leftarrow S_{\langle out \rangle \langle in \rangle}}$, where $\langle out \rangle$ and $\langle in \rangle$ denote the output and input port numbers of the DUT.

Note: For a unidirectional R&S ZND (see [Chapter 5.1.4.3, "R&S ZND: Unidirectional vs. Bidirectional Operation"](#), on page 75) the reverse direction cannot be measured. Hence $Z_{\leftarrow S_{12}}$, $Z_{\leftarrow S_{22}}$ are not available.

Remote command:

```
CALCulate<Ch>:PARAmeter:MEASure "<Trace_Name>", "Z-S11" |
"Z-S12" ...
CALCulate<Ch>:PARAmeter:SDEFine "<Trace_Name>", "Z-S11" |
"Z-S22" | ...
```

Z←S<out><in> softkeys

Selects the 2-port [converted impedance](#) parameters. The parameters describe the impedances of a 2-port DUT, obtained in forward and reverse transmission and reflection measurements:

- Z_{11} is the input impedance at port 1 of a 2-port DUT that is terminated at port 2 with the reference impedance Z_0 (matched-circuit impedance measured in a forward reflection measurement).
- Z_{22} is the input impedance at port 2 of a 2-port DUT that is terminated at port 1 with the reference impedance Z_0 (matched-circuit impedance measured in a reverse reflection measurement).
- Z_{12} and Z_{21} denote the forward and reverse converted transfer impedances, respectively.

Use the Smith chart to obtain an alternative, graphical representation of the converted impedances in a reflection measurement.

Note: For a unidirectional R&S ZND (see [Chapter 5.1.4.3, "R&S ZND: Unidirectional vs. Bidirectional Operation"](#), on page 75) the reverse direction cannot be measured. Hence Z_{12} and Z_{22} are not available.

Tip: For a bidirectional R&S ZND, you can use the "Y- Z-Params" tab to measure Z-parameters including the transfer parameters.

Remote command:

```
CALCulate<Ch>:PARAmeter:MEASure "<Trace_Name>", "Z-S11" |
"Z-S12" | "Z-S21" | "Z-S22"
CALCulate<Ch>:PARAmeter:SDEFine "<Trace_Name>", "Z-S11" |
"Z-S12" | "Z-S21" | "Z-S22"
```

Model

In case a transmission parameter is selected, you can choose between a [series](#) (default), a [parallel](#), and a [shunt](#) impedance calculation.

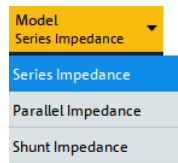

Remote command:

```
CALCulate<Ch>:PARAmeter:MEASure "<Trace_Name>", "Z-S12" |
"Z-S12SER" | "Z-S12PAR" | ...
CALCulate<Ch>:PARAmeter:SDEFine "<Trace_Name>", "Z-S12" |
"Z-S12SER" | "Z-S12PAR" | ...
CALCulate<Ch>:PARAmeter:MEASure "<Trace_Name>", 'SHUNT-S12' |
'SHUNT-S21'
CALCulate<Ch>:PARAmeter:SDEFine "<Trace_Name>", 'SHUNT-S12' |
'SHUNT-S21'
```

Balanced Ports...

Opens a dialog to configure the logical ports of the analyzer.

See [Chapter 6.2.1.3, "Balanced Ports Dialog"](#), on page 226.

6.2.5 $Y \leftarrow S_{ij}$ Tab

Selects converted admittances as measured quantities. The admittances are calculated from the measured S-parameters.



Background information

Refer to the following sections:

- [Chapter 5.3.4, "Admittance Parameters"](#), on page 111
- [Chapter 5.3.4.1, "Converted Admittances"](#), on page 111

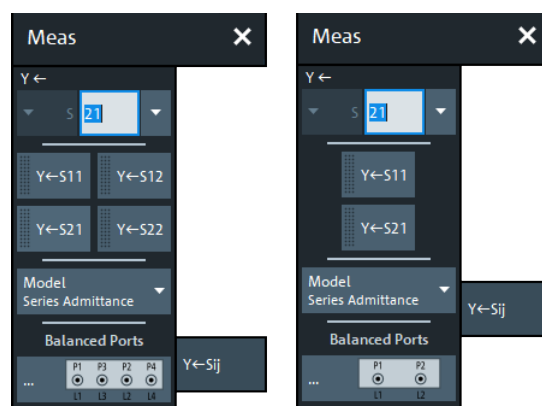

left = bidirectional R&S ZND

right = unidirectional R&S ZND

Y←S<out><in> selector

Selects a [converted admittance](#) parameter as a measured quantity for the active trace. For an n-port vector network analyzer, the pull-down list provides the full set of n^2 admittance parameters.

Converted admittance parameters are expressed as $Y_{\leftarrow S_{\langle out \rangle \langle in \rangle}}$, where $\langle out \rangle$ and $\langle in \rangle$ denote the output and input port numbers of the DUT.

Note: For a unidirectional R&S ZND (see [Chapter 5.1.4.3, "R&S ZND: Unidirectional vs. Bidirectional Operation"](#), on page 75) the reverse direction cannot be measured. Hence $Y_{\leftarrow S_{12}}$, $Y_{\leftarrow S_{22}}$ are not available.

Remote command:

```
CALCulate<Ch>:PARAmeter:MEASure "<Trace_Name>", "Y-S11" |
"Y-S12" ...
CALCulate<Ch>:PARAmeter:SDEFine "<Trace_Name>", "Y-S11" |
"Y-S22" | ...
```

Y←S<out><in> softkeys

Selects the 2-port [converted admittance](#) parameters. The parameters describe the admittances of a 2-port DUT, obtained in forward and reverse transmission and reflection measurements:

- Y_{11} is the input admittance at port 1 of a 2-port DUT that is terminated at port 2 with the reference impedance Z_0 (matched-circuit admittance measured in a forward reflection measurement).
- Y_{22} is the input admittance at port 2 of a 2-port DUT that is terminated at port 1 with the reference impedance Z_0 (matched-circuit admittance measured in a reverse reflection measurement).
- Y_{12} and Y_{21} denote the forward and reverse converted transfer admittances, respectively.

Use the Smith chart to obtain an alternative, graphical representation of the converted impedances in a reflection measurement.

Note: For a unidirectional R&S ZND (see [Chapter 5.1.4.3, "R&S ZND: Unidirectional vs. Bidirectional Operation"](#), on page 75) the reverse direction cannot be measured. Hence Y_{12} and Y_{22} are not available.

Tip: For a bidirectional R&S ZND, you can use the "Y- Z-Params" tab to measure Y-parameters including the transfer parameters.

Remote command:

```
CALCulate<Ch>:PARAmeter:MEASure "<Trace_Name>", "Y-S11" |
"Y-S12" | "Y-S21" | "Y-S22"
CALCulate<Ch>:PARAmeter:SDEFine "<Trace_Name>", "Y-S11" |
"Y-S12" | "Y-S21" | "Y-S22"
```

Model

In case a transmission parameter is selected, you can choose between a [series](#) (default), and a [parallel](#) admittance calculation.

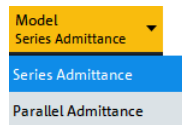

Remote command:

```
CALCulate<Ch>:PARAmeter:MEASure "<Trace_Name>", "Y-S12" |
"Y-S12SER" | "Y-S12PAR" | ...
CALCulate<Ch>:PARAmeter:SDEFine "<Trace_Name>", "Y-S12" |
"Y-S12SER" | "Y-S12PAR" | ...
```

Balanced Ports...

Opens a dialog to configure the logical ports of the analyzer.

See [Chapter 6.2.1.3, "Balanced Ports Dialog"](#), on page 226.

6.2.6 Y-Z-Params Tab

Allows you to select Y- and Z-parameters as measured quantities. Both Y- and Z-parameters can serve as an alternative to S-parameters for characterizing a linear n-port network.



Background information

Refer to the following sections:

- [Chapter 5.3.3, "Impedance Parameters"](#), on page 107
- [Chapter 5.3.4, "Admittance Parameters"](#), on page 111
- [Chapter 5.3.3.2, "Z-Parameters"](#), on page 110
- [Chapter 5.3.4.2, "Y-Parameters"](#), on page 111

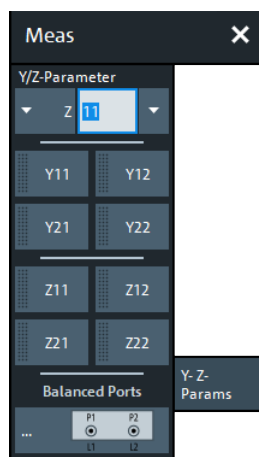

For a unidirectional R&S ZND (see [Chapter 5.1.4.3, "R&S ZND: Unidirectional vs. Bidirectional Operation"](#), on page 75) this tab is not available.

Y/Z-Parameter

Selects an [Y-parameter](#) or [Z-parameter](#) as a measured quantity for the active trace. For an n-port vector network analyzer, the pull-down list provides the full set of n^2 Y- and Z-parameters.

Y- and Z-parameters are expressed as $Y/Z_{\langle out \rangle \langle in \rangle}$, where $\langle out \rangle$ and $\langle in \rangle$ denote the output and input port numbers of the DUT.

Remote command:

```
CALCulate<Ch>:PARAMeter:MEASure "<Trace_Name>", "Y11" |
"Z11" ...
```

```
CALCulate<Ch>:PARAMeter:SDEFine "<Trace_Name>", "Y11" |
"Z11" ...
```

Y11/Y12 /Y21/Y22

Selects one of the 2-port [Chapter 5.3.4.2, "Y-Parameters"](#), on page 111 as a measured quantity for the active trace. The Y-parameters describe the admittances of a DUT with output ports terminated in a short circuit ($V = 0$).

The four 2-port Y-parameters can be interpreted as follows:

- Y_{11} is the input admittance, defined as the ratio of the current I_1 to the voltage V_1 , measured at port 1 (forward measurement with output terminated in a short circuit, $V_2 = 0$).
- Y_{21} is the forward transfer admittance, defined as the ratio of the current I_2 to the voltage V_1 (forward measurement with output terminated in a short circuit, $V_2 = 0$).
- Y_{12} is the reverse transfer admittance, defined as the ratio of the current I_1 to the voltage V_2 (reverse measurement with input terminated in a short circuit, $V_1 = 0$).
- Y_{22} is the output admittance, defined as the ratio of the current I_2 to the voltage V_2 , measured at port 2 (reverse measurement with input terminated in a short circuit, $V_1 = 0$).

Remote command:

```
CALCulate<Ch>:PARAMeter:MEASure "<Trace_Name>", "Y11" | "Y12" |
"Y21" | "Y22"
```

```
CALCulate<Ch>:PARAMeter:SDEFine "<Trace_Name>", "Y11" | "Y12" |
"Y21" | "Y22"
```

Z11 / Z12 / Z21 / Z22

Selects one of the 2-port [Chapter 5.3.3.2, "Z-Parameters"](#), on page 110 as a measured quantity for the active trace. The Z-parameters describe the impedances of a DUT with open output ports ($I = 0$).

The four 2-port Z-parameters can be interpreted as follows:

- Z_{11} is the input impedance, defined as the ratio of the voltage V_1 to the current I_1 , measured at port 1 (forward measurement with open output, $I_2 = 0$).
- Z_{21} is the forward transfer impedance, defined as the ratio of the voltage V_2 to the current I_1 (forward measurement with open output, $I_2 = 0$).
- Z_{12} is the reverse transfer impedance, defined as the ratio of the voltage V_1 to the current I_2 (reverse measurement with open input, $I_1 = 0$).
- Z_{22} is the output impedance, defined as the ratio of the voltage V_2 to the current I_2 , measured at port 2 (reverse measurement with open input, $I_1 = 0$).

Remote command:

```
CALCulate<Ch>:PARAmeter:MEASure "<Trace_Name>", "Z11" | "Z12" |
"Z21" | "Z22"
```

```
CALCulate<Ch>:PARAmeter:SDEFine "<Trace_Name>", "Z11" | "Z12" |
"Z21" | "Z22"
```

Balanced Ports...

Opens a dialog to define a balanced port configuration.

See [Balanced Ports Dialog](#).

6.2.7 Imbal. CMRR Tab

Selects an imbalance or common mode rejection ratio (CMRR) as measured quantity.



This tab is only enabled if a switch matrix is configured.

The "Imbal. CMRR" measurements require at least two logical ports are available, at least one of them balanced.



Background information

Refer to the following sections:

- [Chapter 5.3.6, "Unbalance-Balance Conversion"](#), on page 115
- [Chapter 5.3.6.3, "Imbalance and Common Mode Rejection"](#), on page 119

6.2.7.1 Controls on the Imbal. CMRR Tab



The following buttons in the "Imbal. CMRR" tab open additional dialogs:

- "Imbalance Differential...": see [Chapter 6.2.7.2, "Imbalance Differential Dialog"](#), on page 244.

This button is only enabled, if a balanced and two single-ended logical ports are available.

- "Balanced Ports...": see [Chapter 6.2.1.3, "Balanced Ports Dialog"](#), on page 226

Imbalance/CMRR

Selects an [imbalance or CMRR](#) parameter as a measured quantity for the active trace.

These parameters are expressed as "Imb_{<out><in>}" or "CMRR_{<out><in>}", where <out> and <in> denote the logical output and input port numbers of the DUT.

Remote command:

```
CALCulate<Ch>:PARAmeter:MEASure "<Trace_Name>", "IMB21" |
"IMB12" | "CMRR11" | "CMRR21" | "CMRR12" ...
CALCulate<Ch>:PARAmeter:SDEFine "<Trace_Name>", "IMB21" |
"IMB12" | "CMRR11" | "CMRR21" | "CMRR12" ...
```

Imb21/Imb12 /CMRR21/CMRR12

Selects one of the standard 2-port [imbalance or CMRR](#) parameters as a measured quantity for the active trace. The buttons are available if either logical port 1 or logical port 2 (or both) is defined as a balanced port.

A yellow font color indicates that currently the other logical port number is undefined and the physical port with the same number is marked as unused. If you select it as the measured quantity, the port is automatically enabled as a single-ended port with "logical port number" = "physical port number".

Remote command:

```
CALCulate<Ch>:PARAmeter:MEASure "<Trace_Name>", "IMB21" |
"IMB12" | "CMRR21" | "CMRR12"
CALCulate<Ch>:PARAmeter:SDEFine "<Trace_Name>", "IMB21" |
"IMB12" | "CMRR21" | "CMRR12"
```

6.2.7.2 Imbalance Differential Dialog

Allows you to measure the differential mode imbalance of a DUT with balanced input and output ports, connected to a balanced and two single-ended logical ports at the VNA.

Access: TRACE – [MEAS] > "Imbal. CMRR" > "Imbalance Differential..."

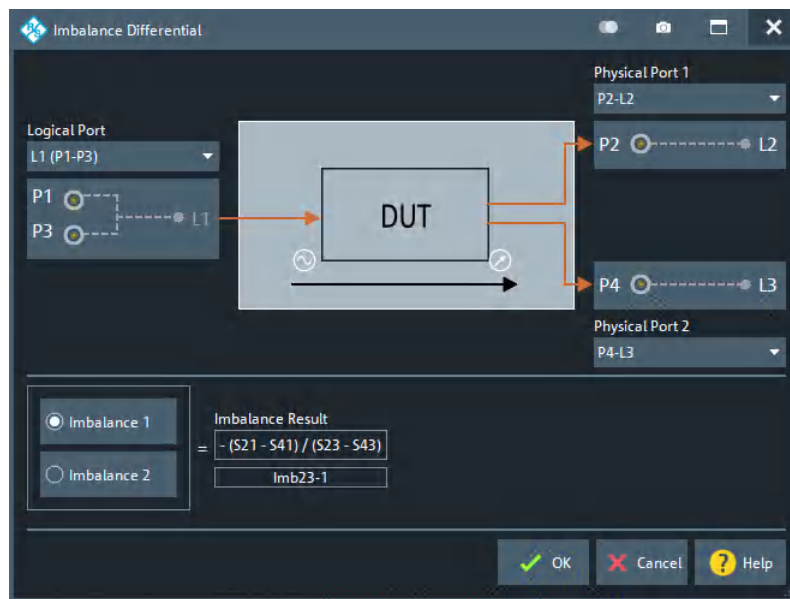

This dialog can only be opened, if a balanced and two single-ended logical ports are configured in the [Balanced Ports Dialog](#).

- The **Logical Port** on the left represents the balanced test port: any (active) balanced logical port can be selected
- Physical Port 1 and Physical Port 2 represent the two single-ended test ports: any two (active) single-ended logical ports can be selected
- The part below allows you to select the signal direction and hence the "Imbalance Result" to be calculated.

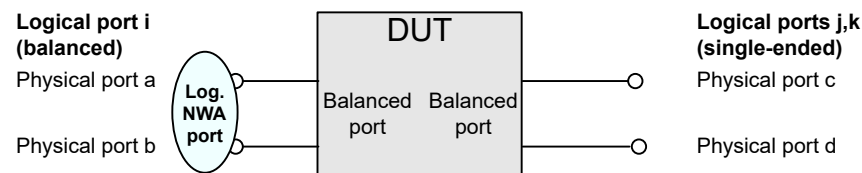

Imbalance 1 / Imbalance 2

Imbalance 1 selects the balanced logical port *i* as the input, the single-ended logical ports *j* and *k* as the output and calculates the following imbalance parameter:

$$\text{Imb}_{jk-i} = -(S_{ca} - S_{da}) / (S_{cb} - S_{db})$$

Imbalance 2 selects the balanced logical port *i* as the output, the single-ended logical ports *j* and *k* as the input and calculates the following imbalance parameter:

$$\text{Imb}_{i-jk} = -(S_{ac} - S_{ad}) / (S_{bc} - S_{bd})$$

Remote command:

```
CALCulate<Ch>:PARAmeter:MEASure "<Trace_Name>", "IMB<i>-<j><k>"
| "IMB<j><k>-<i>"
CALCulate<Ch>:PARAmeter:SDEFine "<Trace_Name>", "IMB<i>-<j><k>"
| "IMB<j><k>-<i>"
```

6.2.8 Stability Tab

Selects one of the three two port stability factors K , μ_1 or μ_2 as measured quantities. A typical application of stability factors is to assess the stability of an amplifier. Stability factors cannot be calculated in balanced port configurations.



Background information

Refer to [Chapter 5.3.7, "Stability Factors"](#), on page 120.



For a unidirectional R&S ZND (see [Chapter 5.1.4.3, "R&S ZND: Unidirectional vs. Bidirectional Operation"](#), on page 75) this tab is not available.

Stability

Selects a [stability factor](#) as a measured quantity for the active trace. The stability factor calculation is based on 2-port reflection **and** transmission S-parameters so that the input and output port numbers must be different. The pull-down list contains all possible physical (single-ended) port combinations. For an analyzer with n ports, provides $n * (n - 1)$ stability parameters.

Stability parameters are expressed as " $K_{\langle out \rangle \langle in \rangle}$ ", " $\mu 1_{\langle out \rangle \langle in \rangle}$ ", and " $\mu 2_{\langle out \rangle \langle in \rangle}$ ", where $\langle out \rangle$ and $\langle in \rangle$ denote the logical output and input port numbers of the DUT.

Remote command:

```
CALCulate<Ch>:PARAMeter:MEASure "<Trace_Name>", "KFAC21" |
"MUF121" | "MUF221" | ...
CALCulate<Ch>:PARAMeter:SDEFine "<Trace_Name>", "KFAC21" |
"MUF121" | "MUF221" | ...
```

$\mu 1$ 21/ $\mu 2$ 21/ K 21

Selects one of the standard 2-port [stability factors](#) as a measured quantity for the active trace. These buttons are enabled if none of the logical ports 1 and 2 is defined as a balanced port.

Remote command:

```
CALCulate<Ch>:PARAmeter:MEASure "<Trace_Name>", "MUF121" |
"MUF221" | "KFAC21"
CALCulate<Ch>:PARAmeter:SDEFine "<Trace_Name>", "MUF121" |
"MUF221" | "KFAC21"
```

Balanced Ports...

Opens a dialog to define a balanced port configuration.

See [Chapter 6.2.1.3, "Balanced Ports Dialog"](#), on page 226.

6.2.9 Power Sensor Tab

Allows you to set up and perform measurements using external power sensors.

The standard test setup for a "Power Sensor" measurement involves one analyzer source port and a power sensor. The power sensor is connected to the VNA (e.g. to the analyzer's USB port) and provides scalar wave quantity results. See [Chapter 5.7.19, "External Power Meters"](#), on page 208.

Power Meter

Shows a list of all power meters that have been properly configured. See ["Configured Devices"](#) on page 544.

The bordered label below displays the type and serial number of the selected power meter.

Remote command:

```
CALCulate<Ch>:PARAmeter:MEASure 'TraceName', 'PmtrD1 | ...
CALCulate<Ch>:PARAmeter:SDEFine 'TraceName', 'PmtrD1 | ...
```

Auto Zero

Initiates an automatic zeroing procedure of the power meter which must be disconnected from the RF power; see ["Zeroing"](#) on page 210. A message indicates that zeroing is finished.

Remote command:

```
SYSTem:COMMunicate:RDEvice:PMETer<Pmtr>:AZERo
```

Source Port

Selects one of the available test ports of the analyzer as a source of the stimulus signal.

Note: For a unidirectional R&S ZND (see [Chapter 5.1.4.3, "R&S ZND: Unidirectional vs. Bidirectional Operation"](#), on page 75) only port 1 may serve as source and hence this control is disabled.

Remote command:

```
CALCulate<Ch>:PARAmeter:MEASure 'TraceName', 'PmtrD1 | ...
CALCulate<Ch>:PARAmeter:SDEFine 'TraceName', 'PmtrD1 | ...
```

Show as

Selects the physical unit of the displayed trace. It is possible to display the measured "Voltage" V or convert it to a "Power" according to the formula

$$P = V^2/\text{Re}(Z_0).$$

Z_0 denotes the reference impedance of the source port. The reference impedances are defined in the "Balanced Ports" dialog (see [Chapter 6.2.1.3, "Balanced Ports Dialog"](#), on page 226).

Remote command:

`CALCulate<Chn>:FORMat:WQUType`

6.2.10 External DLL Tab

The "External DLL" tab allows you to add/remove custom plug-ins to/from the firmware. It gives access to their configuration, tasks, and traces.

**Background information**

Refer to [Chapter 5.7.21, "External DLLs"](#), on page 216.

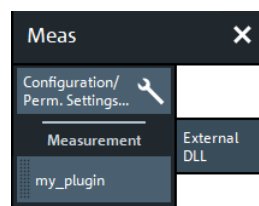
6.2.10.1 Controls on the External DLL Tab**Configuration / Perm. Settings**

Opens the [External DLL Configuration Dialog](#).

Measurement

The "Measurement" section gives access to the custom traces of the loaded plug-ins.

Each external DLL `<ext_dll_name>.dll` that provides at least one custom trace type, adds a measurement button "`<ext_dll_name>`" (with dotted left border) to the "Measurement" section of the "External DLL" tab. If neither the PAE plugin nor any custom external DLL is installed, the "Measurement" section is hidden.

Tapping (clicking) or dragging & dropping a measurement button to the diagram area, opens an additional [Trace Definition Dialog](#).

As usual, tapping (clicking) redefines the current trace while dragging & dropping creates a trace.

6.2.10.2 External DLL Configuration Dialog

In the "External DLL Configuration" dialog, you can add/remove [External DLLs](#) to/from the firmware. If a plugin requires interaction with an external device, you can define its address from here.



To add/remove external DLLs, the firmware has to be run as administrator.

(Close the analyzer GUI, tap and hold the "R&S ZNA Vector Network Analyzer" icon on the desktop and select "Run as administrator"

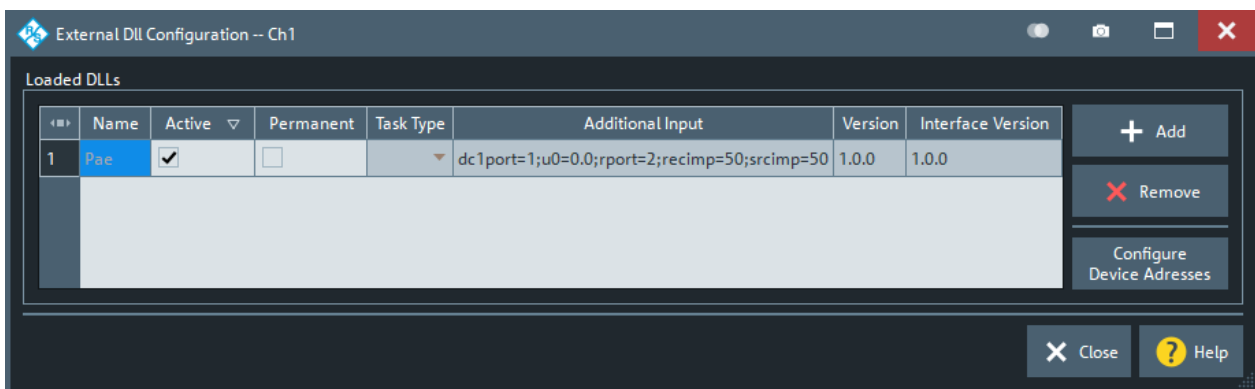

Loaded DLLs table

Displays the loaded plug-in DLLs and their configuration in the current channel.

Remote command:

`[SENSe:] CDLL:LIST?`

Active ← Loaded DLLs table

Allows you to de-/activate the respective plugin in the current channel. An active plugin can be used to [create traces](#) and/or can be made [Permanent](#).

Remote command:

`[SENSe<Ch>:] CDLL[:STATE]`

Permanent ← Loaded DLLs table

Defines the task that is selected via [Task Type](#) and further defined via "[Additional Input](#)" on page 250 as permanent.

A permanent task can interact with the firmware, even if it currently does not provide any traces, e.g. for synchronized control of an external device. In contrast to the trace mode, the permanent mode of operation is not restricted to a particular driving port.

Remote command:

`[SENSe<Ch>:] CDLL:PERmanent[:STATE]`

Task Type ← Permanent ← Loaded DLLs table

Displays the task types implemented by the external DLL. This combo-box is only enabled, if the DLL is marked as permanent.

Remote command:

`[SENSe<Ch>:] CDLL:PERmanent:TASK`

Additional Input ← Permanent ← Loaded DLLs table

Specifies additional input that further specifies the permanent task to be performed by the external DLL.

This string is processed by the external DLL, with DLL-specific syntax and semantics. If it is malformed or inappropriate for some reason, the firmware logs and displays the error messages that are returned by the DLL. See the docs of your DLL for details.

Remote command:

```
[SENSe<Ch>:]CDLL:PERManent:ADDitional
```

Version/Interface Version ← Loaded DLLs table

"Version" is purely informative. It reports the version of the DLL, as specified by its developer.

"Interface Version" is the version of the plug-in SDK that was used to compile the DLL (more precisely, the version of the interface `RsVnaCustomDllInterface.h` against which it was compiled). This version can change the DLL handling of the analyzer firmware.

Add / Remove

Allows you to add/remove custom plugins to/from the analyzer firmware.

A plug-in is installed as a *.zip file, containing a DLL and, possibly, some additional files.

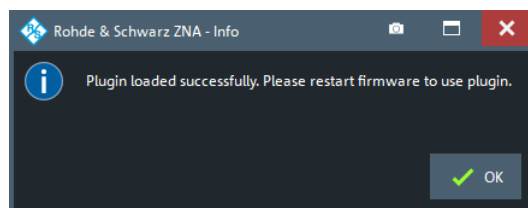
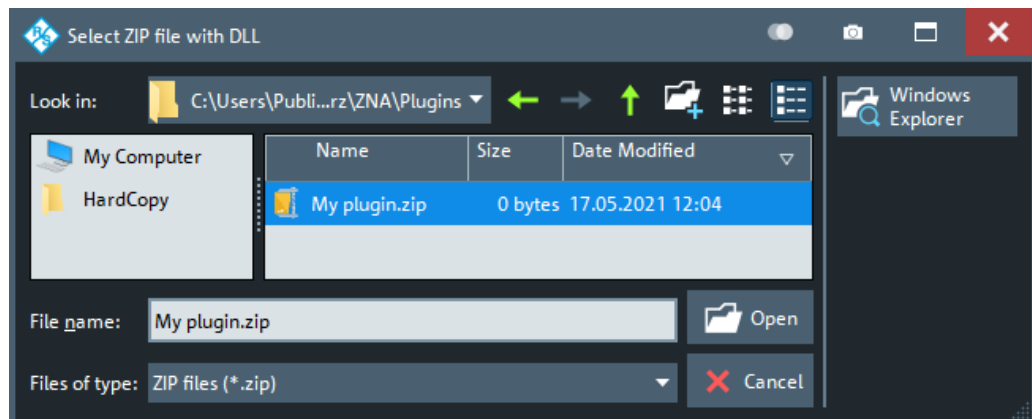

The firmware must be run as administrator to add or remove custom plugins. Once installed, standard user privileges are sufficient to use a plugin's functionality.

Remote command:

```
[SENSe:]CDLL:ADD
```

```
[SENSe:]CDLL:REMOve
```

Configure Device Address

Opens an additional dialog that allows you to specify the addresses of external devices the external DLL requires to complete its tasks. For each task type, a single device address can be configured.

The address syntax is DLL-specific: the DLL manages the connection to the external device. In the example below, the DLL expects a VISA resource string and the VNA operator indicates that the device is connected to (virtual) COM port 4.

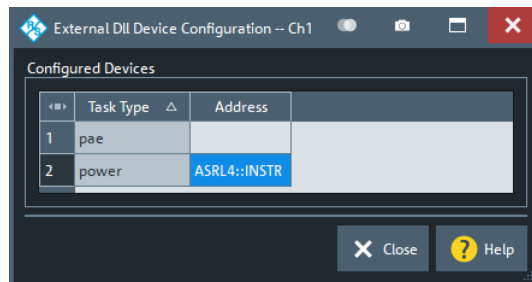

Remote command:

```
[SENSe<Ch>:] CDLL:TASK:ADDRESS
```

6.2.10.3 Trace Definition Dialog

Specifies a custom trace that is provided by an external DLL.

Access: [External DLL Tab](#) > "Measurement" section buttons

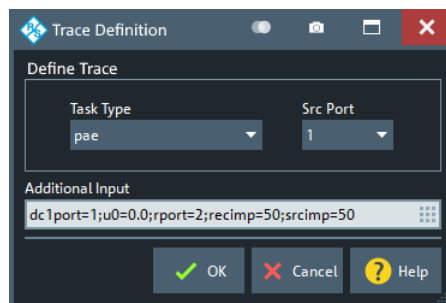

Figure 6-1: Trace Definition dialog

In the VNA firmware, the following string represents the measured quantity:

Cu(P<Src Port><lowercase_ext_dll_name><Task Type><Additional Input>

This string is displayed in the trace info and in the "Trace Manager". You can also use it to specify the corresponding <Result> in remote commands:

- `CALCulate<Ch>:PARAMeter:MEASure`
- `CALCulate<Ch>:PARAMeter:SDEFine`

Define Trace

Requests the external DLL, for which the [Trace Definition Dialog](#) was called, to calculate a particular trace.

- "Task Type" selects the task that is responsible for calculating this kind of trace

- The trace is calculated when "Src Port" is the (physical) driving port

In the [Figure 6-1](#), for example, the external DLL provides a task to calculate PAE (power added efficiency) traces. The user requests the PAE trace calculation while port 1 is the driving port.

"Task Type" and "Src Port" define the first part of the trace identifier:

Cu(P<Src Port><lowercase_ext_dll_name>/<Task Type>/<Additional Input>

If these selections are insufficient to fully specify the trace, [Additional Input](#) can be provided to the respective task.

Additional Input

For some task types, the basic information in "Define Trace" can be supplemented with "Additional Input". This string is processed by the external DLL, with DLL-specific syntax and semantics. If it is malformed or inappropriate for some reason, the firmware logs and displays the error messages that are returned by the DLL. See the docs of your DLL for details.

In [Figure 6-1](#), for example, the external DLL plugin is provided with additional information about the source and receive impedance (*recimp=50;srcimp=50*) to calculate the PAE trace correctly.

The "Additional Input" is the last part of the trace identifier:

Cu(P<Src Port><lowercase_ext_dll_name>/<Task Type>/<Additional Input>

6.3 Format Softtool

The "Format" softtool allows you to define how the measured data is presented in the diagram area.

Access: TRACE – [FORMAT]



Measured quantities and display formats

The analyzer allows arbitrary combinations of display formats and measured quantities (see [Chapter 6.2, "Meas Softtool"](#), on page 221). Nevertheless, to extract useful information from the data, it is important to select a display format which is appropriate to the analysis of a particular measured quantity.

An extended range of formats is available for markers. To convert any point on a trace, create a marker and select the appropriate marker format (see ["Marker Format"](#) on page 326). Marker and trace formats can be applied independently.



Background information

Refer to the following sections:

- [Chapter 5.2.3, "Trace Formats"](#), on page 95
- [Chapter 5.2.3.3, "Measured Quantities and Trace Formats"](#), on page 103

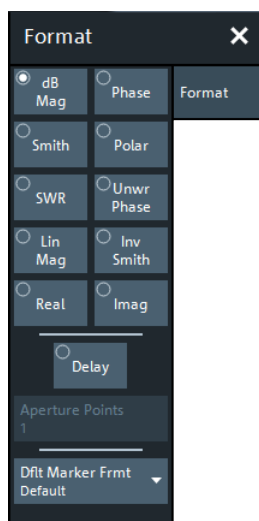

dB Mag

Selects a Cartesian diagram with a dB scale of the vertical axis to display the magnitude of the complex measured quantity.

Properties: The stimulus variable appears on the horizontal axis, scaled linearly. The magnitude of the complex quantity C , i.e. $|C| = \sqrt{\text{Re}(C)^2 + \text{Im}(C)^2}$, appears on the vertical axis, scaled in dB. The decibel conversion is calculated according to $\text{dB Mag}(C) = 20 * \log(|C|)$ dB.

Application: dB Mag is the default format for the complex, dimensionless S-parameters. The dB-scale is the natural scale for measurements related to power ratios (insertion loss, gain etc.).

Tip (alternative formats): The magnitude of each complex quantity can be displayed on a linear scale. It is possible to view the real and imaginary parts instead of the magnitude and phase. Both the magnitude and phase are displayed in the polar diagram.

Remote command:

`CALCulate<Chn>:FORMat MLOGarithmic`

Phase

Selects a Cartesian diagram with a linear vertical axis to display the phase of a complex measured quantity in the range between -180 degrees and $+180$ degrees.

Properties: The stimulus variable appears on the horizontal axis, scaled linearly. The phase of the complex quantity C , i.e. $\varphi(C) = \arctan(\text{Im}(C) / \text{Re}(C))$, appears on the vertical axis. $\varphi(C)$ is measured relative to the phase at the start of the sweep (reference phase = 0°). If $\varphi(C)$ exceeds $+180^\circ$ the curve jumps by -360° ; if it falls below -180° , the trace jumps by $+360^\circ$. The result is a trace with a typical sawtooth shape. The alternative "Unwr Phase" format avoids this behavior.

Application: Phase measurements, e.g. phase distortion, deviation from linearity.

Tip (alternative formats): The magnitude of each complex quantity can be displayed on a linear scale or on a logarithmic scale. It is possible to view the real and imaginary parts instead of the magnitude and phase. Both the magnitude and phase are displayed in the polar diagram. As an alternative to direct phase measurements, the analyzer provides the derivative of the phase response for a frequency sweep ([Delay](#)).

Remote command:

`CALCulate<Chn>:FORMat PHASe`

Smith

Selects a Smith chart to display a complex quantity, primarily a reflection S-parameter.

Properties: The Smith chart is a circular diagram obtained by mapping the positive complex semi-plane into a unit circle. Points with the same resistance are located on circles, points with the same reactance produce arcs. If the measured quantity is a complex reflection coefficient S_{ij} , then the unit Smith chart represents the normalized impedance. In contrast to the polar diagram, the scaling of the diagram is not linear.

Application: Reflection measurements; see example in "Smith" on page 98.

Tip: The axis for the sweep variable is lost in Smith charts but the marker functions easily provide the stimulus value of any measurement point. dB values for the magnitude and other conversions can be obtained by the "Marker Format" functions.

Remote command:

`CALCulate<Chn>:FORMat SMITh`

Polar

Selects a polar diagram to display a complex quantity, primarily an S-parameter or ratio.

Properties: The polar diagram shows the measured data (response values) in the complex plane with a horizontal real axis and a vertical imaginary axis. The magnitude of a complex value is determined by its distance from the center, its phase is given by the angle from the positive horizontal axis. In contrast to the Smith chart, the scaling of the axes is linear.

Application: Reflection or transmission measurements, see example in "Polar" on page 97.

Tip: The axis for the sweep variable is lost in polar diagrams but the marker functions easily provide the stimulus value of any measurement point. dB values for the magnitude and other conversions can be obtained by the "Marker Format" functions.

Remote command:

`CALCulate<Chn>:FORMat POLar`

SWR

Calculates the standing wave ratio (SWR) from the measured quantity (typically a reflection S-parameter) and displays it in a Cartesian diagram.

Properties: The SWR (or voltage standing wave ratio, VSWR) is a measure of the power reflected at the input of the DUT. It is calculated from the magnitude of the reflection coefficients S_{ii} (where i denotes the port number of the DUT) according to:

$$SWR = \frac{1 + |S_{ii}|}{1 - |S_{ii}|}$$

The superposition of incident and reflected wave on the transmission line connecting the analyzer and the DUT causes an interference pattern with variable envelope voltage. The SWR is the ratio of the maximum voltage to the minimum envelope voltage along the line.

Interpretation of the SWR

The superposition of the incident wave I and the reflected wave R on the transmission line connecting the analyzer and the DUT causes an interference pattern with variable envelope voltage. The SWR is the ratio of the maximum voltage to the minimum envelope voltage along the line:

$$\text{SWR} = V_{\text{Max}}/V_{\text{Min}} = (|V_I| + |V_R|) / (|V_I| - |V_R|) = (1 + |S_{ii}|) / (1 - |S_{ii}|)$$

Application: Reflection measurements with conversion of the complex S-parameter to a real SWR.

Remote command:

`CALCulate<Chn>:FORMat SWR`

Unwr Phase

Selects a Cartesian diagram with an arbitrarily scaled linear vertical axis to display the phase of the measured quantity.

Properties: The stimulus variable appears on the horizontal axis, scaled linearly. The phase of the complex quantity C, i.e. $\varphi(C) = \arctan(\text{Im}(C) / \text{Re}(C))$, appears on the vertical axis. $\varphi(C)$ is measured relative to the phase at the start of the sweep (reference phase = 0°). In contrast to the normal [Phase](#) format, the display range is not limited to values between -180° and +180°. This format avoids artificial jumps of the trace but can entail a relatively wide phase range if the sweep span is large.

Application: Phase measurements, e.g. phase distortion, deviation from linearity.

Tip: After changing to the "Unwr Phase" format, use the "Auto Scale Trace" function to rescale the vertical axis and view the entire trace (see ["Auto Scale Trace"](#) on page 260).

Remote command:

`CALCulate<Chn>:FORMat UPHase`

Lin Mag

Selects a Cartesian diagram with a linear vertical axis scale to display the magnitude of the measured quantity.

Properties: The stimulus variable appears on the horizontal axis, scaled linearly. The magnitude of the complex quantity C, i.e. $|C| = \sqrt{\text{Re}(C)^2 + \text{Im}(C)^2}$, appears on the vertical axis, also scaled linearly.

Application: Real measurement data (i.e. the stability factors and the DC voltages) are always displayed in a Lin Mag diagram.

Tip (alternative formats): The magnitude of each complex quantity can be displayed on a logarithmic scale. It is possible to view the real and imaginary parts instead of the magnitude and phase.

Remote command:

`CALCulate<Chn>:FORMat MLINear`

Log Mag

Selects a Cartesian diagram with a logarithmic (base 10) vertical axis scale to display the magnitude of the measured quantity.

Properties: The stimulus variable appears on the horizontal axis, scaled linearly. The magnitude of the complex quantity C , i.e. $|C| = \sqrt{\text{Re}(C)^2 + \text{Im}(C)^2}$, appears on the vertical axis, scaled logarithmically.

Application: Impedance measurements

Remote command:

`CALCulate<Chn>:FORMat LOGarithmic`

Real

Selects a Cartesian diagram to display the real part of a complex measured quantity.

Properties: The stimulus variable appears on the horizontal axis, scaled linearly. The real part $\text{Re}(C)$ of the complex quantity $C = \text{Re}(C) + j \text{Im}(C)$, appears on the vertical axis, also scaled linearly.

Application: The real part of an impedance corresponds to its resistive portion.

Tip (alternative formats): It is possible to view the magnitude and phase of a complex quantity instead of the real and imaginary part. The magnitude can be displayed on a linear scale or on a logarithmic scale. Both the real and imaginary parts are displayed in the polar diagram.

Remote command:

`CALCulate<Chn>:FORMat REAL`

Imag

Selects a Cartesian diagram to display the imaginary part of a complex measured quantity.

Properties: The stimulus variable appears on the horizontal axis, scaled linearly. The imaginary part $\text{Im}(C)$ of the complex quantity $C = \text{Re}(C) + j \text{Im}(C)$, appears on the vertical axis, also scaled linearly.

Application: The imaginary part of an impedance corresponds to its reactive portion. Positive (negative) values represent inductive (capacitive) reactance.

Tip (alternative formats): It is possible to view the magnitude and phase of a complex quantity instead of the real and imaginary part. The magnitude can be displayed on a linear scale or on a logarithmic scale. Both the real and imaginary parts are displayed in the polar diagram.

Remote command:

`CALCulate<Chn>:FORMat IMAGinary`

Inv Smith

Selects an inverted Smith chart to display a complex quantity, primarily a reflection S -parameter.

Properties: The inverted Smith chart is a circular diagram obtained by mapping the positive complex semi-plane into a unit circle. If the measured quantity is a complex reflection coefficient S_{ij} , then the unit inverted Smith chart represents the normalized admittance. In contrast to the polar diagram, the scaling of the diagram is not linear.

Application: Reflection measurements, see example in "Inv Smith" on page 100.

Tip: The axis for the sweep variable is lost in Smith charts but the marker functions easily provide the stimulus value of any measurement point. dB values for the magnitude and other conversions can be obtained by the "Marker Format" functions.

Remote command:

`CALCulate<Chn>:FORMat ISMith`

Delay

Calculates the (group) delay from the measured quantity (typically a transmission S-parameter) and displays it in a Cartesian diagram.

Properties: The group delay τ_g represents the propagation time of wave through a device. τ_g is a real quantity and is calculated as the negative of the derivative of its phase response. A non-dispersive DUT shows a linear phase response, which produces a constant delay (a constant ratio of phase difference to frequency difference).

For more information, refer to [Chapter 5.3.8, "Delay, Aperture, Electrical Length"](#), on page 121.

Application: Transmission measurements, especially with the purpose of investigating deviations from linear phase response and phase distortions. To obtain the delay, a frequency sweep must be active.

Tip: The cables between the analyzer test ports and the DUT introduce an unwanted delay, which often can be assumed to be constant. Use the Zero Delay at Marker function, define a numeric length "Offset" or use the "Auto Length" function to compensate for this effect in the measurement results. To compensate for a frequency-dependent delay in the test setup, a system error correction is required.

Note: The delay for reflection factors corresponds to the transmission time in forward and reverse direction; see ["Length and delay measurement, related settings"](#) on page 175.

Remote command:

`CALCulate<Chn>:FORMat GDElay`

Aperture Points

Defines an aperture Δf for the (group) "Delay" calculation. The value is entered as number of "Aperture Points" (i.e. sweep steps).

Properties: The delay at each sweep point is computed as:

$$\tau_{g,meas} = -\frac{\Delta\phi_{deg}}{360^\circ \cdot \Delta f}$$

where the aperture Δf is a finite frequency interval around the sweep point f_0 and the analyzer measures the corresponding phase change $\Delta\Phi$.

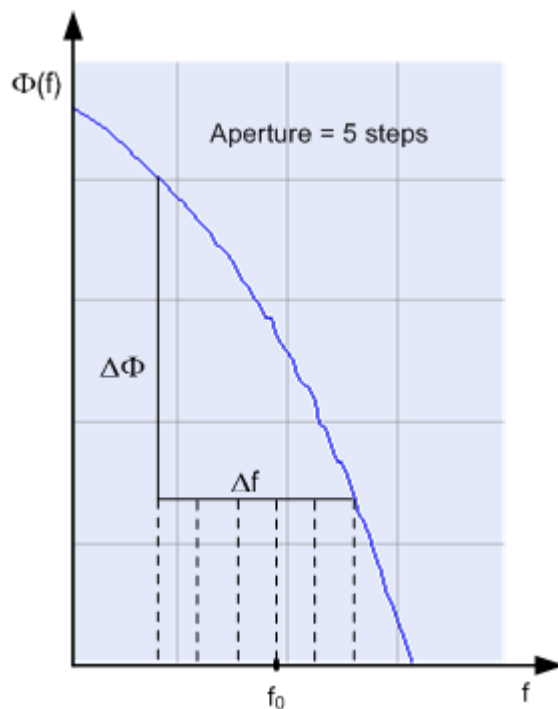

Calculation of Δf and $\Delta\Phi$

With n sweep steps the delay at sweep point no. m is calculated as follows:

- If n is even ($n = 2k$), then $\Delta f(m) = f(m+k) - f(m-k)$ and $\Delta\Phi(m) = \Delta\Phi(m+k) - \Delta\Phi(m-k)$.
- If n is odd ($n = 2k+1$), then $\Delta f(m) = f(m+k) - f(m-k-1)$ and $\Delta\Phi(m) = \Delta\Phi(m+k) - \Delta\Phi(m-k-1)$.

The calculated phase difference (and thus the group delay) is always assigned to the frequency point no. m .

For linear sweeps, if the number of aperture steps is odd, then the center of the aperture range is $[f(m+k) + f(m-k-1)] / 2 = f(m-1/2)$. I.e. the center is half a frequency step below the sweep point $f(m)$. Hence, toggling from even to odd numbers of aperture steps and back can virtually shift the group delay curve towards higher/lower frequencies. It is recommended, to use even numbers of aperture steps, especially for large frequency step sizes.

The delay calculation is based on the already measured sweep points and does not slow down the measurement.

Δf is constant over the entire sweep range, if the sweep type is a Lin. Frequency sweep. For logarithmic and segmented frequency sweeps, it varies with the sweep point number m .

Application: The aperture must be adjusted to the conditions of the measurement. A small aperture increases the noise in the group delay; a large aperture tends to minimize the effects of noise and phase uncertainty, but at the expense of frequency resolution. Phase distortions (i.e. deviations from linear phase) which are narrower in frequency than the aperture tend to be smeared over and cannot be measured.

Remote command:

`CALCulate<Chn>:GDAPerture:SCount`

Dflt Marker Frmt

Defines the default marker format of the active trace. "Default" means formatted according to the selected trace format.

New markers are formatted with the trace's "Dflt Marker Frmt"; existing markers are reformatted if (and only if) their [Marker Format](#) is set to (Trace) "Default".

For background information on marker formats, see "[Marker Format](#)" on page 86.

Remote command:

`CALCulate<Chn>:MARKer:DEFault:FORMat`

6.4 Scale Softtool

The "Scale" softtool allows you to define how the active trace is displayed in its current format.

Access: TRACE – [SCALE] hardkey

6.4.1 Scale Values Tab

Provides the functions for diagram scaling.

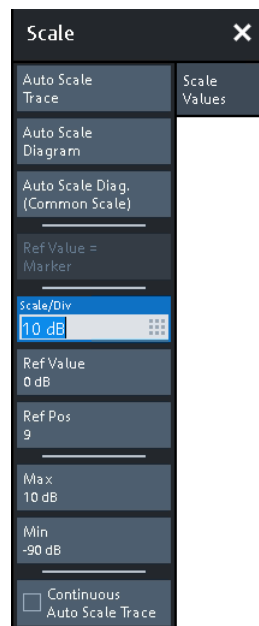

The "Scale Values" settings are closely related to the "Format" and "Display" settings.

The "Scale Values" settings depend on the current trace format (diagram type) because not all diagrams can be scaled in the same way:

- In Cartesian diagrams, all scale settings are available.
- In circular diagrams, no "Scale/Div", no "Ref Pos", and no "Max" and "Min" values can be defined.

The default scale is activated automatically when a display format (diagram type) is selected. Scale settings that are not compatible with the current display format are unavailable (grayed out).

Relations between the scaling parameters

The scaling parameters "Scale/Div", "Ref Value", "Ref Pos", "Max", and "Min" are coupled together in the following manner:

- $\text{"Max"} - \text{"Min"} = \text{"Scale/Div"} \cdot \text{<Number of graticule divisions>}$
- $\text{"Max"} = \text{"Ref Value"}$ when "Ref Value" is 10
- $\text{"Min"} = \text{"Ref Value"}$ when "Ref Value" is 0



Alternatives to Scaling

There are several alternatives to manual trace/diagram scaling. Refer to the following sections:

- [Chapter 4.3.6, "Scaling Diagrams"](#), on page 54
- [Chapter 6.8.1, "Stimulus Tab"](#), on page 345

Auto Scale Trace

Adjusts the "Scale/Div" and the "Ref Value" to display the entire active trace in the diagram area, leaving an appropriate display margin.

- In Cartesian diagrams, the analyzer recalculates the values of the vertical divisions so that the trace fits onto approx. 80% of the vertical grid. The reference value is chosen to center the trace in the diagram.
- In circular diagrams ("Polar", "Smith", "Inv Smith"), the analyzer recalculates the values of the radial divisions so that the diagram is confined to approx. 80% of the outer circumference. The reference value is set to the value of the outer circumference.

Auto scale does not affect the stimulus values and the horizontal axis.

Remote command:

```
DISPlay[:WINDow<Wnd>]:TRACe<WndTr>:Y[:SCALe]:AUTO
```

Auto Scale Diagram

Adjusts the "Scale/Div" and the "Ref Value" to display all traces in the diagram area, leaving an appropriate display margin. All traces in the active diagram are scaled independently (see ["Auto Scale Trace"](#) on page 260), and irrespective of their channel assignment.

Auto Scale Diag. (Common Scale)

Similar to ["Auto Scale Diagram"](#) on page 260, but scales equally formatted traces together.

Ref Value = Marker

See ["Ref Val = Marker / Max = Marker / Min = Marker"](#) on page 342.

Scale/Div

Sets the value of the vertical diagram divisions in Cartesian diagrams.

"Scale/Div" corresponds to the increment between two consecutive grid lines. The unit depends on the display format: dB for display format "dB Mag", degrees for "Phase" and "Unwr Phase", ns for "Delay", U (units) for all other (dimensionless) formats.

"Scale/Div" is not available for circular diagrams ("Polar", "Smith", "Inv Smith").

Remote command:

```
DISPlay[:WINDow<Wnd>]:TRACe<WndTr>:Y[:SCALe]:PDIVision
```

Ref Value

Sets the reference line of a Cartesian diagram or the outer circumference of a circular diagram.

- In Cartesian diagrams "Ref Value" defines the value of the reference line, indicated by an arrowhead symbol at the right edge of the diagram area. The color of the symbol corresponds to the trace color. As the "Ref Value" is varied, the position of the reference line ("Ref Pos") is left unchanged, so that the current trace is shifted in vertical direction. The unit of the "Ref Value" depends on the display format: dB for display format "dB Mag", degrees for "Phase" and "Unwr Phase", ns for "Delay", U (units) for all other (dimensionless) formats.
- In circular diagrams ("Polar", "Smith", "Inv Smith"), "Ref Value" defines the value of the outer circumference. Changing "Ref Value" enlarges or scales down the diagram, leaving the center unchanged. The unit is U (units) for all circular diagrams.

Remote command:

```
DISPlay[:WINDow<Wnd>]:TRACe<WndTr>:Y[:SCALe]:RLEVEL
```

Ref Pos

Defines the position of the reference line in a Cartesian diagram.

The reference line is indicated by an arrowhead symbol at the right edge of the diagram area. The color of the symbol corresponds to the trace color. "Ref Pos" is defined on a linear scale between 0 (bottom line of the diagram) and 10 (top line of the diagram). As the "Ref Pos" is varied, the value of the reference line ("Ref Value") is left unchanged, so the current trace is shifted together with the "Ref Pos".

"Ref Pos" is not available (grayed) for polar diagrams ("Polar", "Smith", "Inv Smith").

Remote command:

```
DISPlay[:WINDow<Wnd>]:TRACe<WndTr>:Y[:SCALe]:RPOSITION
```

Max / Min

Define the upper and lower edge of a Cartesian diagram.

"Max" and "Min" are not available (grayed) for polar diagrams ("Polar", "Smith", "Inv Smith").

Remote command:

```
DISPlay[:WINDow<Wnd>]:TRACe<WndTr>:Y[:SCALe]:TOP
DISPlay[:WINDow<Wnd>]:TRACe<WndTr>:Y[:SCALe]:BOTTom
```

Continuous Auto Scale Trace

Similar to [Auto Scale Trace](#), but applies auto-scaling continuously, even during a running sweep.

Remote command:

n.a.

6.4.2 Scale Coupling Tab

Selects common scale settings for all traces. The softkeys are available if the active recall set contains at least two traces, and if the active trace is not a reference trace ("To Trace").



Related settings

Refer to [Chapter 6.5.1.3, "Trace Manager Dialog"](#), on page 267.

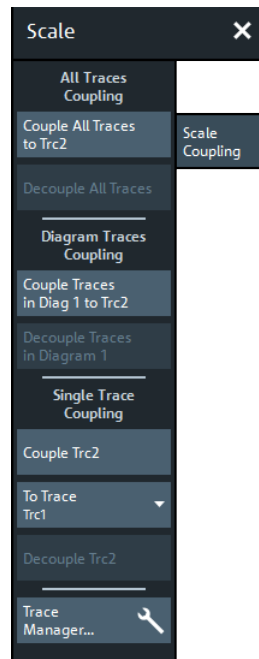

The "Trace Manager..." button opens the [Trace Manager Dialog](#).

Couple All Traces / Couple Trc ... To Trace

Applies the scale settings of the reference trace ("To Trace") to all traces / to the active trace.

Remote command:
n/a

Decouple All Traces / Decouple Trc

Assigns independent scale settings to all traces / to the active trace.

Remote command:
n/a

6.4.3 Zoom Tab

Provides graphical and stimulus zoom functions for cartesian diagrams.

The graphical zoom magnifies a (paraxial) rectangular portion of a diagram without modifying any sweep parameters. The stimulus zoom also magnifies the selected rect-

angle, but at the same time narrows the sweep range of the active channel to the rectangle's horizontal range.



Alternatives to Zooming

There are several alternatives to graphical/numerical zooming. Refer to the following sections:

- [Chapter 4.3.6, "Scaling Diagrams"](#), on page 54
- [Chapter 6.4.1, "Scale Values Tab"](#), on page 259
- [Chapter 6.8.1, "Stimulus Tab"](#), on page 345

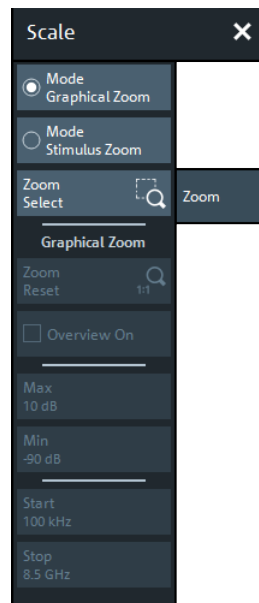

Mode Graphical Zoom/Mode Stimulus Zoom

Switches between graphical and stimulus zoom mode.

Use the [zoom selection button](#) to initiate the selection of a (paraxial) rectangular zoom area. Its label changes according to the selected zoom mode.

Remote command:

n.a.

Zoom Select/Stim. Zoom Select

Prepares the analyzer GUI for the selection of a (paraxial) rectangular zoom area.

The effect of the subsequent selection depends on the current [zoom mode](#) (as indicated on the button label):

- In "Mode Graphical Zoom" (button label "Zoom Select"), the selected rectangle is magnified without modifying any sweep parameters.
- In "Mode Stimulus Zoom" (button label "Stim. Zoom Select") the selected rectangle is magnified as well, but at the same time the sweep range of the active channel is narrowed to the rectangle's horizontal range.

You can define the zoom area using touchscreen or mouse. To modify the zoom window in graphical zoom mode, you can also use the numerical input fields "Max", "Min", "Start", and "Stop".

Remote command:

```
DISPlay[:WINDow<Wnd>]:TRACe<WndTr>:ZOOM[:STATe]
```

Zoom Reset

If a [graphical zoom](#) has been applied to the current diagram, this action resets the zoom area.

Remote command:

```
DISPlay[:WINDow<Wnd>]:TRACe<WndTr>:ZOOM[:STATe]
```

Overview On

If a [graphical zoom](#) has been applied to the active diagram (and has not been [reset](#), this button toggles the overview for this diagram.

The overview appears in the upper part of the diagram and shows the original diagram and the zoom area. You can move the zoomed part of the trace by moving the zoom area or use the numerical input fields "Max", "Min", "Start", "Stop" to do so.

Remote command:

```
DISPlay[:WINDow<Wnd>]:TRACe<WndTr>:ZOOM[:STATe]
```

Max / Min / Start / Stop

Defines the coordinates of the graphical zoom window for the active diagram. "Max" and "Min" define the response axis range, "Start" and "Stop" define the stimulus axis range.

The input fields are only enabled if a zoom area was selected before.

Remote command:

```
DISPlay[:WINDow<Wnd>]:TRACe<WndTr>:ZOOM:BOTTOm
```

```
DISPlay[:WINDow<Wnd>]:TRACe<WndTr>:ZOOM:START
```

```
DISPlay[:WINDow<Wnd>]:TRACe<WndTr>:ZOOM:STOP
```

```
DISPlay[:WINDow<Wnd>]:TRACe<WndTr>:ZOOM:TOP
```

6.5 Trace Config Softtool

The "Trace Config" softtool provides functions for managing traces.

Access: TRACE – [TRACE CONFIG]

6.5.1 Traces Tab

Provides functions to handle traces and diagram areas, and assign traces to channels.



Related information

Refer to the following sections:

- [Chapter 5.1.3, "Traces, Channels and Diagrams"](#), on page 70
- [Chapter 4.3.4, "Handling Diagrams, Traces, and Markers"](#), on page 47



In remote control, each channel can contain an active trace. The active remote traces and the active manual trace are independent of each other; see [Chapter 7.3.2, "Active Traces in Remote Control"](#), on page 573.

6.5.1.1 Controls on the Traces Tab

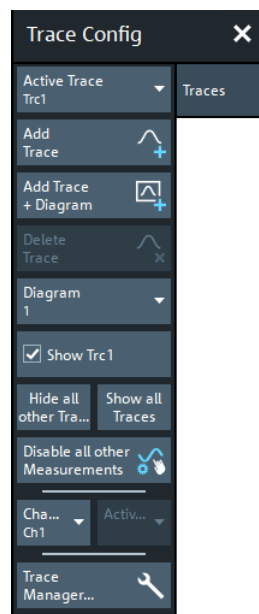

The "Trace Manager..." button opens the [Trace Manager Dialog](#).

Active Trace

Selects an arbitrary trace of the active recall set as the active trace in its channel and diagram. At the same time, it sets the trace's diagram and channel as the active [Diagram / Channel](#).

Tip: You can also select an item in a trace list or a trace line in a diagram to make the related trace the active one.

This function is disabled if only one trace is defined.

Add Trace

Creates a trace in the active [Diagram / Channel](#) and makes it the [Active Trace](#).

The new trace is created with the settings of the former active trace, but displayed in another color. The former and the new active trace overlay each other. Change the reference position or select a different measurement for the new trace to separate them (see [Chapter 6.2, "Meas Softtool"](#), on page 221).

The new trace is named "Trc<n>", where <n> is the largest of all existing trace numbers plus one. The name can be changed in the [Trace Manager Dialog](#).

Remote command:

```
CALCulate<Ch>:PARAmeter:SDEFine
DISPlay[:WINDow<Wnd>]:TRACe<WndTr>:FEED
```

Add Tr+Diag

Creates a trace in the active channel and assigns it to a new diagram. Otherwise behaves like [Add Trace](#).

Remote command:

```
CALCulate<Ch>:PARAmeter:SDEFine
DISPlay[:WINDow<Wnd>][:STATe] ON
DISPlay[:WINDow<Wnd>]:TRACe<WndTr>:FEED
```

Delete Trace

Deletes the active trace and removes it from the diagram area. If the active diagram contains only one trace, the diagram is also deleted.

"Delete Trace" is disabled if the active recall set contains only one trace. In manual control, each recall set must contain at least one diagram area with one channel and one trace.

Tips:

- You can also hide traces without actually deleting them: remove the corresponding "On" flags in the "Trace Manager" (see [Chapter 6.5.1.3, "Trace Manager Dialog"](#), on page 267).
- Use the undo function to restore a trace that was unintentionally deleted.

Remote command:

```
CALCulate<Ch>:PARAmeter:DELeTe
CALCulate:PARAmeter:DELeTe:ALL
CALCulate<Ch>:PARAmeter:DELeTe:CALL
```

Diagram / Channel

Displays the active diagram and channel, i.e. the diagram and channel of the [Active Trace](#). Allows you to move the active trace to another diagram or channel.

Remote command:

```
DISPlay[:WINDow<Wnd>]:TRACe<WndTr>:FEED
```

Show <Trace Name> / Hide All Other Traces / Show All Traces

Configures the visibility of the traces in the active diagram:

- "Show <Trace Name>" toggles the visibility of the [Active Trace](#)
- "Hide All Other Traces" hides all traces of the active diagram – except the active one (which can be visible or not)
- "Show All Traces" makes all traces of the active diagram visible

Note:

- These actions can also be performed from the context menu of the trace name segment in the trace list (see [Chapter 5.2.1.4, "Channel List and Channel Settings"](#), on page 90).

- Use the "On" flags in the "Trace Manager" to show/hide arbitrary sets of traces (see [Chapter 6.5.1.3, "Trace Manager Dialog"](#), on page 267).

Disable all other Measurements/Enable all Measurements

Toggle button with alternating caption.

Same functionality as the  toggle button of the [Chapter 4.3.2.2, "Toolbar"](#), on page 41

"Disable all other Measurements"

- Disables all channels, except the active one
- Disables all traces in the active channel, except the active one
- Hides all diagrams except the active one

"Enable all Measurements" Restores the previous channel/trace/diagram configuration

Same functionality as the

6.5.1.2 New Trace Dialog

The "Trc+" tool bar button allows you to create a trace in the active channel.

- Tap/click the "Trc+" button to duplicate the active trace (equivalent to [Add Trace](#)).
- Drag the respective button onto the diagram area to create the trace in any other existing diagram or in a new one.

After the button has been dropped, the "New Trace" dialog pops up and lets you select the quantity to be measured.

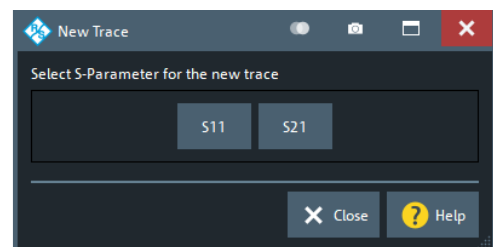
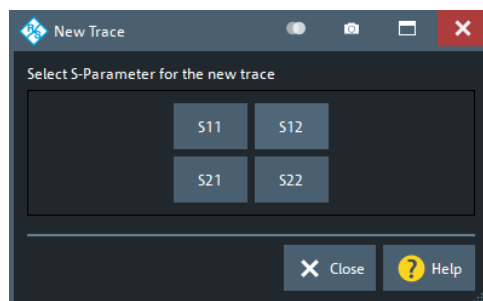

left = bidirectional R&S ZND
right = unidirectional R&S ZND

6.5.1.3 Trace Manager Dialog

The "Trace Manager" dialog allows you to perform operations on traces.

Access: TRACE – [TRACE CONFIG] > "Traces" > "Trace Manager..."

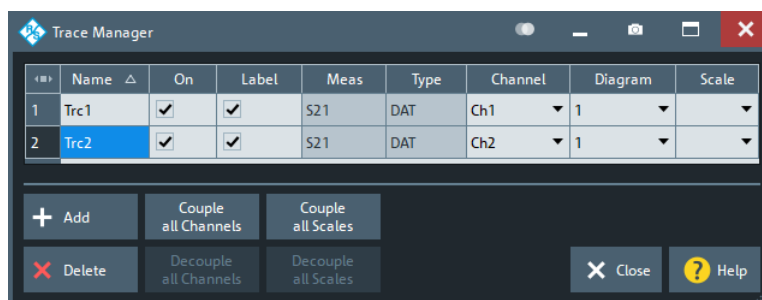

All existing traces of the current recall set are listed in a table with several editable (white) or non-editable (gray) columns.

Table Area

The table contains the following columns:

- "Name" indicates name of the related trace.
Trace names must be unambiguous across all channels and diagram areas in a recall set.
- "On" indicates and controls the visibility of the related trace.
- "Label" indicates and controls the visibility of the related trace label
- "Meas" indicates the measured parameter.
- "Type" indicates whether the trace is a data trace ("DAT"), displaying the current measurement data, or a memory trace ("MEM").
- "Channel" indicates and controls the channel to which the related trace is assigned.
Data traces and their associated memory traces are always assigned to the same channel.
- "Diagram" indicates and controls the diagram area to which the related trace is assigned.
- "Scale" indicates and controls the scale coupling of the related trace.
A trace's scaling can either be uncoupled ("Scale" empty) or coupled to another trace's scaling.

Rules for trace names

The analyzer can define mathematical relations between different traces and calculate new mathematical traces ("User Def Math"). The trace names are used as operands in the mathematical expressions and must be distinguished from the mathematical operators +, -, *, /, (,) etc., which places some restrictions on the syntax of trace names.

- The first character of a trace name can be one of the following:
 - an upper case letter from A to Z, or lower case letter from a to z
 - an underscore _
 - a square bracket [or]
- For all other characters of a trace name, the numbers 0 to 9 can be used in addition.

Note: The analyzer does not accept illegal or ambiguous trace names. If an illegal or ambiguous name is specified, the entry is denied.

Remote command:

`CONFigure:TRACe:CATalog?`

`CONFigure:CHANnel<Ch>:TRACe:CATalog?`

`CONFigure:TRACe<Trc>:REName`

`CONFigure:CHANnel<Ch>:TRACe:REName`

`DISPlay[:WINDow<Wnd>]:TRACe<WndTr>:SHOW`
`DISPlay[:WINDow<Wnd>]:TRACe<WndTr>:LABel:SHOW` on page 809
`CONFigure:TRACe:WINDow:TRACe?`
`DISPlay[:WINDow<Wnd>]:TRACe<WndTr>:FEED`
`CONFigure:CHANnel<Ch>:NAME:ID?`

Add

Creates a trace based on the [Active Trace](#). In particular, the trace is assigned to the channel and diagram of the active trace. However, its "Scale" coupling is not adopted.

The default names for new traces are "Trc<n>", where <n> is selected by the analyzer firmware to make trace names unambiguous.

Remote command:

`CALCulate<Ch>:PARAmeter:SDEFine`

Delete

Deletes the selected trace.

This button is disabled if the recall set contains only one trace: In manual control, each recall set must contain at least one diagram area with one channel and one trace.

Remote command:

`CALCulate<Ch>:PARAmeter:DElete`

Couple All Channels / Decouple All Channels

- "Couple All Channels" assigns all traces to the channel of the active trace, deleting all other (now unused) channels. The analyzer displays a confirmation dialog box before deleting the unused channels.
- "Decouple All Channels" makes sure that each data trace is assigned its own (independent) channel. For data traces previously assigned to the same channel, new channels are created based on the original channel's settings. Data traces and their associated memory traces are assigned to the same channel.

Remote command:

n/a

Couple All Scales / Decouple All Scales

- "Couple All Scales" couples the scale settings of all traces to the scale settings of the active trace. The scale settings of the other traces are lost.
- "Decouple All Scales" applies independent scale settings to all traces. If trace A is coupled to trace B, then B's scale settings are copied to A.

Remote command:

n/a

6.5.2 Mem

Stores traces to the memory.



Background information

Refer to ["Trace Types"](#) on page 82.

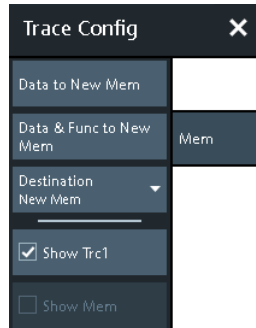

Coupling of data and memory traces

When a memory trace is generated from a data trace, it is displayed in the same diagram area and inherits all channel and trace settings from the data trace. The memory trace displayed in the active diagram; its properties are indicated in the trace list:



New memory traces are named "Mem<n>[<Data Trace>]", where:

- <n> counts all data and memory traces in the active recall set in chronological order
- <Data_Trace> is the name of the associated data trace

Trace names can be changed in the [Trace Manager Dialog](#).

The following display settings of a data trace and the associated memory traces are **fully coupled**. Changing a property of one trace affects the properties of all other traces.

- All "Format" settings (see [Chapter 6.3, "Format Softtool"](#), on page 252)
- All "Scale" settings (see [Chapter 6.4, "Scale Softtool"](#), on page 259)

Selection of the measured quantity (using the [Meas Softtool](#)) is possible for the data trace but disabled for the memory traces.

Channel settings made for a memory trace act on the associated data trace. Some of the channel settings for a data trace (e.g. the "Stimulus" range) also affect the display of the memory traces.



If, due to a change of the sweep type, the stimulus type of a data trace changes, all its memory traces are deleted.

Active Trace vs. Active Data Trace

In the context of memory traces we distinguish between the active trace and the active data trace.

- If the active trace is a memory trace, then the active data trace is the data trace to which the memory trace is associated.
- If the active trace is a data trace, then the active trace is also the active data trace.

Data to <Destination>

Stores the current state of the active data trace to the [Destination](#) memory trace. No trace functions are applied to the stored trace.

Tips:

- Use [Data & Func to <Destination>](#) to apply trace functions to the stored trace.
- You can also create memory traces using the [Import Complex Data Dialog](#).
- It is not possible to store [Hold](#) traces to memory.
- For the relation between a data trace and its associated memory traces, see "[Coupling of data and memory traces](#)" on page 270.

Remote command:

```
CALCulate<Chn>:MATH:MEMorize
TRACe:COPIE
```

Data & Func to <Destination>

Stores the current state of the active data trace – including trace functions – to the [Destination](#) memory trace.

Trace functions

The trace functions comprise the following mathematical operations:

- Active trace math on unformatted and formatted traces, as configured in the [Chapter 6.5.4, "Math Tab"](#), on page 273.
- A shift of the data trace (see "[Shift Trace](#)" on page 294).

[Data to <Destination>](#) stores the raw trace without the trace functions, "[Data & Func to <Destination>](#)" stores the trace after it has been transformed using the trace functions.

For the relation between a data trace and its associated memory traces, see "[Coupling of data and memory traces](#)" on page 270.

Remote command:

```
CALCulate<Chn>:MATH:MEMorize
```

Destination

Selects the destination for the [Data to <Destination>](#) and [Data & Func to <Destination>](#) operations.

The destination can be one of the following:

- An existing memory trace of the active data trace.
The existing memory trace is overwritten.
- "New Trace"
The data are copied to a new memory trace, associated to the current data trace.

Remote command:

n/a

Show <Active Data Trace>

Shows or hides the active data trace in the diagram.

Remote command:

```
DISPlay[:WINDow<Wnd>]:TRACe<WndTr>:SHOW
```

Show <Mem>

Shows or hides the active memory trace or the first memory trace of the active data trace.

If no memory trace is associated with the active data trace, "Show <Mem>" is disabled.

Remote command:

```
DISPlay[:WINDow<Wnd>]:TRACe<WndTr>:SHOW
```

6.5.3 All Mem All Data Tab

Performs actions on all data or memory traces in the active recall set.

**Background information**

Refer to "[Trace Types](#)" on page 82.

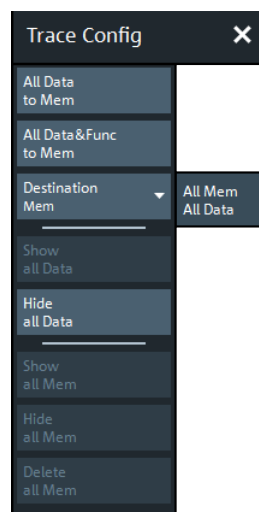
**All Data to <Destination>**

Stores the current data of all data traces in the active recall set to memory traces, in accordance with the [Destination](#) setting. No trace functions are applied to the stored traces.

Remote command:

```
TRACe:COPY
```

All Data & Func to <Destination>

Stores the current data of all data traces in the active recall set to memory traces, in accordance with the [Destination](#) setting. Trace functions are applied to the stored traces.

For information on trace functions, see "Data & Func to <Destination>" on page 271.

[All Data to <Destination>](#) stores the raw trace without the trace functions, "All Data & Func to <Destination>" stores the trace after it has been transformed using trace functions.

Remote command:

`CALCulate<Chn>:MATH:MEMorize`

Destination

Selects the destination for the [All Data to <Destination>](#) and [All Data & Func to <Destination>](#) functions, that operate on all data traces in the active recall set.

- **"Mem":**
For each data trace with associated memory traces, the current trace data are copied to the first associated memory trace, overwriting existing data. For data traces without associated memory trace, the current trace data are copied to a new memory trace, associated to this data trace.
- **"New":**
For each data trace, the current trace data are copied to a new memory trace, associated to this data trace.

New memory traces are named "Mem<n>[<Data_Trace>]" with <n> selected by the analyzer firmware to make trace names unique.

Remote command:

n/a

Show All Data / Hide All Data / Show All Mem / Hide All Mem

Displays or hides all data or memory traces in the active recall set. Hidden traces are not deleted.

Remote command:

`DISPlay[:WINDow<Wnd>]:TRACe<WndTr>:SHOW`

Delete All Mem

Deletes all memory traces in the active recall set.

Tips:

- Use the [Trace Manager Dialog](#) to hide or delete arbitrary sets of traces.
- Use the UNDO function of the analyzer to restore a trace that was unintentionally deleted.

Remote command:

`CALCulate:PARAmeter:DELeTe:MEMory`

6.5.4 Math Tab

Allows you to define mathematical operations on traces.



Background information

Refer to "[Trace Types](#)" on page 82.

6.5.4.1 Controls on the Math Tab

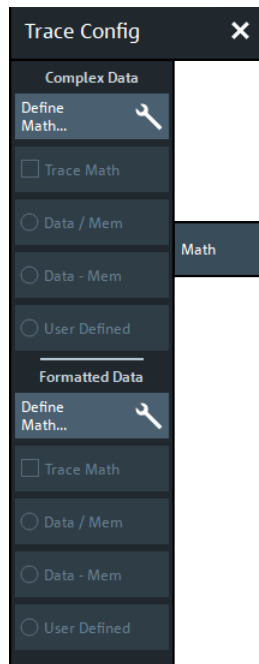

The "Define Math..." buttons in the "Complex Data" and "Formatted Data" sections both open the [User Def Math Dialog](#), but with different scope:

- "Complex Data" > "Define Math..." defines mathematical operations on raw complex trace data.
- "Formatted Data" > "Define Math..." defines mathematical operations on formatted trace data.

Both can be combined.

Complex Data/Formatted Data

The controls in the "Complex Data" section define math operations on raw complex trace data, the controls in the "Formatted Data" section define math operations on formatted trace data.

"Complex Data" math is available in all firmware versions of all R&S ZNx vector network analyzers. "Formatted Data" math was added in version 3.0 of the R&S ZND firmware.

Trace Math ← Complex Data/Formatted Data

Activates or deactivates the "Complex Data" and/or "Formatted Data" formula previously defined using [Data / <Mem>](#), [Data - <Mem>](#), or "Define Math..." (via [Chapter 6.5.4.2, "User Def Math Dialog"](#), on page 275).

Trace math for unformatted and formatted trace data can be active at the same time.

Trace Math ← Complex Data/Formatted Data

Activates the mathematical mode, applying the last active mathematical relation to the active trace. The trace is replaced by the mathematical trace and Math is displayed in the trace list while the mathematical mode is active:

Trc1 S21 dB Mag 10 dB/Ref 0 dB Math

"Trace Math" is enabled if the active data trace fulfills the conditions for evaluating the mathematical relation. E.g., if no "User Defined" mathematical relation is defined, a memory trace must be coupled to the active data trace, so that the R&S ZND can evaluate one of the relations "Data / <Mem>" or "Data - <Mem>".

Remote command:

`CALCulate<Chn>:MATH:STATe`

`CALCulate<Chn>:MATH:FORMatted:STATe`

Data / <Mem>, Data - <Mem> ← Complex Data/Formatted Data

Activates the mathematical mode with the corresponding trace mathematical operation. The division (subtraction) is calculated on a point-to-point basis: Each measurement point of the active trace is divided by (subtracted from) the corresponding measurement point of the memory trace. If the memory trace represents the result of a previous sweep with unchanged settings, the divided (subtracted) curve is typically centered at 1 / 0 dB (0). It shows the variation of the results in subsequent sweeps.

The result of the division is a mathematical trace and replaces the active data trace in the diagram area. The mathematical trace is updated as the measurement goes on and the analyzer provides new active trace data.

This function is disabled unless a memory trace is coupled to the active data trace. Trace coupling ensures that the two traces have the same number of points so that the mathematical trace is well-defined.

Remote command:

`CALCulate<Chn>:MATH:FUNctIon`

`CALCulate<Chn>:MATH:FORMatted:FUNctIon`

User Defined ← Complex Data/Formatted Data

Activates the mathematical mode and displays the mathematical trace defined using in the "User Def Math" dialog (see [Chapter 6.5.4.2, "User Def Math Dialog"](#), on page 275).

The mathematical trace replaces the active data trace in the diagram area; it is updated as the measurement goes on and the analyzer provides new active trace data.

Remote command:

`CALCulate<Chn>:MATH:STATe`

6.5.4.2 User Def Math Dialog

The "User Def Math" dialog defines a mathematical trace for the active trace. Each measurement point of the original trace is replaced by the corresponding point of the mathematical trace.

Access: TRACE – [TRACE CONFIG] > Math > Complex Data/Formatted Data section > "Define Math..."

Depending on the section from where the dialog is opened, the calculation is either based on unformatted or formatted trace data.

Compatibility between traces in mathematical relations

Mathematical traces are either constant functions or functions of one or more data or memory traces. They are calculated on a point-to-point basis. Each trace point no. i of the mathematical trace is calculated from a set of constant values c_1, \dots, c_n plus the trace points $\text{Trc1}_i, \text{Trcm}_i$ of all traces 1 to m in the mathematical relation:

$$\text{Math}_i = \text{Fct.} (c_1, \dots, c_n, \text{Trc1}_i, \text{Trcm}_i), i = 1, \text{ no. of points}$$

Different traces can be used in the same mathematical relation provided that they contain the same number of points. The analyzer places no further restriction on the compatibility of traces, e.g. the sweep points of the traces do not have to be the same.

The number of points belongs to the channel settings. Coupled data and memory traces are always compatible because they have the same channel settings.



The analyzer processes only numeric values without units in the mathematical formulas. No consistency check for units is performed.

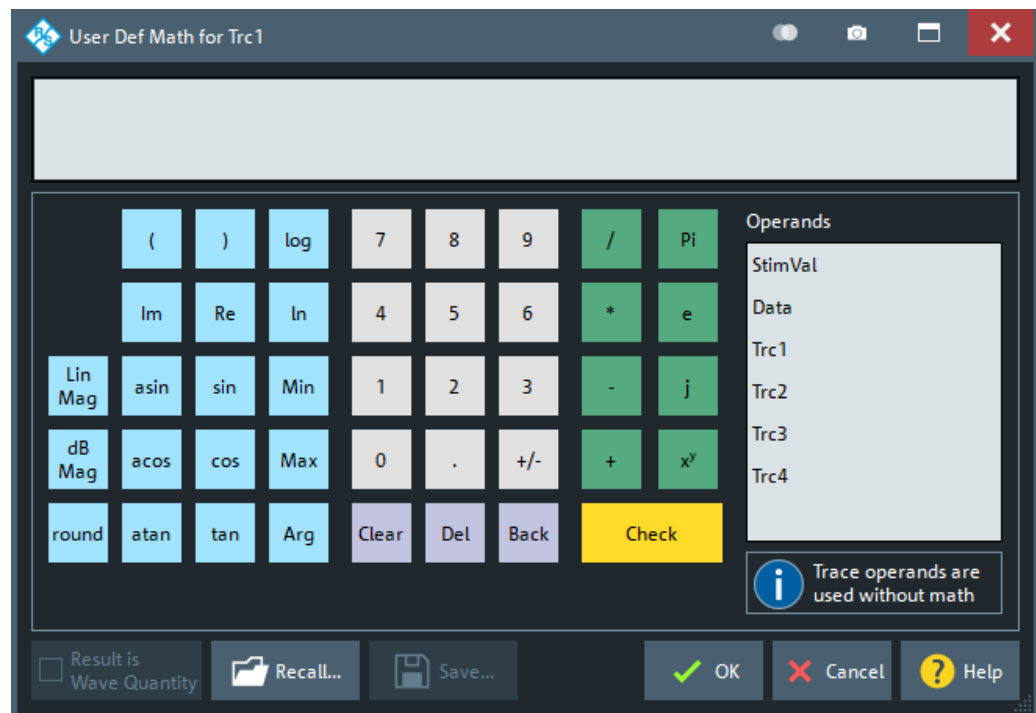

Expression builder

The mathematical expression appears in the upper part of the dialog. The operands and operators in the expression can be selected from a keyboard and the list of "Operands":

- The keyboard supports the entry of numeric values, constants, and mathematical functions. In addition to the numbers 0 to 9, the decimal point and the constants j (complex unit), π (approx. 3.14159) and e (approx. 2.71828), it contains the following buttons:
 - +/- changes the sign

- The effect of the basic arithmetic operators ($/$, $*$, $-$, $+$) and the mathematical functions is described in [Table 6-2](#).
Products of numbers and constants may be entered in abbreviated form, e.g. $2e$ for $2*e$.
- The Clear, Del, Back buttons are used to correct faulty entries.
- Check performs a consistency check of the displayed mathematical expression and displays a message.
- "Operands" contains all data traces and memory traces of the active recall set.
 - Data and memory traces are identified by their trace names.
 - "Data" denotes the active data trace.
 - "Mem" is the memory trace associated with the active data trace (or the first created one, if several memory traces are associated with the active data trace).
 - "StimVal" is the array of stimulus values; see footnote for [Table 6-2](#).

The trace operands denote *unmodified* data and memory traces. Trace math and other trace functions ("Smoothing", "Hold", "Shift Trace" etc.) are not taken into account.

Table 6-2: Effect of the operators on a complex quantity $z = x + jy$.

$+$, $-$, $*$, $/$	Basic arithmetic operations
$()$	Grouping parts of an expression
Lin Mag	$ z = \text{sqrt}(x^2 + y^2)$
dB Mag	$\text{dB Mag}(z) = 20 * \log z \text{ dB}$
round	x real \Rightarrow round(x) rounds x to the closest integer (away from zero for ties) x, y real \Rightarrow round($x+yj$) = round(x)+round(y) j
x^y	Exponential, e.g. z^2
Arg	Phase $\varphi(z) = \arctan(\text{Im}(z) / \text{Re}(z))$
Re, Im	x, y (Real and Imag)
log, ln	Common (base 10) or natural (base e) logarithm
Min, Max	Smaller or larger values of all points of two traces, e.g. Min(Trc1, Trc2)
StimVal *)	Stimulus value*)
tan, atan, sin, asin, cos, acos	Direct and inverse trigonometric functions.

*) The operand "StimVal" can be used for all sweep types. Please note that – as with all user math operands – only the numerical value without unit is processed in the user math formula.

- In frequency sweeps "StimVal" provides the stimulus frequency in Hz.
- In power sweeps, "StimVal" provides the voltage in V that results from the source power in dBm. To obtain the correct source power in dBm (for "dB Mag" trace format), [Result is Wave Quantity](#) must be enabled. Note that, due to the conversion into a dBm value, the source power depends on the reference impedance of the port associated with the measured wave quantity, to be set in the "Balanced Ports" dialog.

- In time sweeps, "StimVal" is the stimulus time in s.
- In CW mode sweeps, "StimVal" is the number of the point.

Remote command:

```
CALCulate<Chn>:MATH[:EXPRession]:SDEFine
```

```
CALCulate<Chn>:MATH:FORMatted[:EXPRession]:SDEFine
```

Result is Wave Quantity

"Result is Wave Quantity" controls the conversion and formatting of the mathematic expression.

This switch is available for **unformatted** trace data (Complex Data) only.

- If "Result is Wave Quantity" is enabled, the analyzer assumes that the result of the mathematical expression represents a voltage. Examples for voltage-type expressions are all terms proportional to a wave quantity (e.g. $1.1 * \text{Data}$, if a wave quantity is measured) or to a stimulus value of a power sweep.
If "Show as": "Power" is selected in the "More Wave Quantities" dialog, the result is converted into a linear power before the selected trace format is applied. Otherwise no conversion is performed, and "dB Mag" results are referenced to $1 \mu\text{V}$.
- If "Result is Wave Quantity" is disabled the analyzer assumes that the result of the mathematical expression is dimensionless. Examples for dimensionless expressions are all terms proportional to ratios of wave quantities, e.g. $\text{Data} / \text{Mem2}[\text{Trc1}]$. The selected trace format is applied without previous conversion.

"Result is Wave Quantity" acts on the result of the mathematical expression only. Wave quantities and power sweep stimulus values always enter into the expression as voltages.

Effect of "Result is Wave Quantity"

In the [More Wave Quantities Dialog](#), the "Show as" control element specifies whether wave quantities are displayed as voltages or equivalent powers, using the port impedances for a conversion between the two representations. "Result is Wave Quantity" is relevant for mathematical traces displayed in units of dBm ("Show as": "Power" and trace format "dB Mag"):

If "Result is Wave Quantity" is on (checked), the mathematical trace values $\langle W \rangle$ are interpreted as voltages and first converted into equivalent powers ($\langle W \rangle \rightarrow \langle P \rangle = \langle W \rangle^2 / \text{Re}(Z_0)$). Results in "dB Mag" format are calculated according to $\langle P \rangle_{\log} = 10 * \log(\langle P \rangle / 1\text{mW})$.

- If "Result is Wave Quantity" is off, the mathematical trace values $\langle W \rangle$ are interpreted as dimensionless quantities. Results in "dB Mag" format are calculated according to $\langle W \rangle_{\log} = 20 * \log(\langle W \rangle)$.

Example:

A mathematical trace value amounts to 1 (real value); the port impedance is 50Ω . If "Result is Wave Quantity" is on, the analyzer assumes the trace value to be 1 V, which is converted into a linear power of 20 mW, corresponding to approx. 13 dBm. With "Result is Wave Quantity" off, the trace value 1 is directly converted into a logarithmic power of 0 dBm.

Tip: See also example for `CALCulate<Chn>:MATH:WUNit:STATe`.

Remote command:

`CALCulate<Chn>:MATH:WUNit[:STATe]`

Recall... / Save...

Recalls / saves a mathematical expression from / to a trace math string file. Trace math string files are ASCII files with the default extension `*.mth` and contain the mathematical expression as it is written in the "User Def Math" dialog. It is possible to change or create math string files using a text editor.

Remote command:

`CALCulate<Chn>:MATH:WUNit[:STATe]`

6.5.5 Time Domain Tab

The "Time Domain" tab enables and configures the time domain representation of the measurement results.



Time domain analysis requires option R&S ZND-K2. If this option is not installed, the "Time Domain" and [Time Gate Tab](#) tabs are hidden.



Background information

Refer to [Chapter 5.7.5, "Time Domain Analysis"](#), on page 193.

For a comparison of the different transformation types and windows, and for application examples, please also refer to the application note 1EZ44_OE (<https://www.rohde-schwarz.com/appnote/1EZ44>).

6.5.5.1 Controls on the Time Domain Tab

The contents of the "Time Domain" tab are also displayed on the "Meas" softtool for non-frequency converting DUTs.

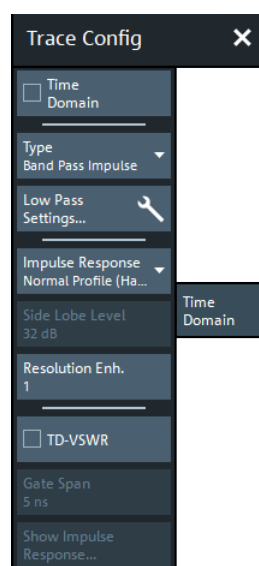

"Low Pass Settings..." opens the [Low Pass Settings Dialog](#).

Time Domain

Selects the time domain representation for the active diagram area. The softkey is enabled if a linear frequency sweep is active (see ["Lin Freq"](#) on page 355). The analyzer automatically quits time domain representation when a different sweep type is selected.

The time domain results are obtained by transforming the measured frequency sweep data into the time domain using an appropriate mathematical transformation type and frequency window ("Impulse Response"). The sweep range and the output power for the active channel is still displayed below the diagram; the displayed time interval is shown in a second line:

```
Ch1 Start 1 MHz Pwr -10 dBm Bw 10 kHz Stop 3 GHz
Trc1 Start -1 ns Time Domain Stop 4 ns
```

Trace settings in time domain representation

While the time domain representation is active, the trace settings behave as follows:

- The "Start" and "Stop" settings in the "Time Gate" tab configure the time axis.
- All trace formats including the circular diagrams are available.
- Limit lines can be defined like the limit lines for time sweeps.
- The bandfilter search functions are available for the transformed trace.
- If marker coupling is active, then the markers in the time domain and in the frequency domain are coupled with each other.

The analyzer places no restriction on the measured quantities to be transformed into the time domain. Impedances and admittances are first converted back into the equivalent S-parameter, transformed, and restored after the transformation.

See also [Chapter 5.7.5.1, "Chirp z-Transformation"](#), on page 193.

Remote command:

```
CALCulate<Chn>:TRANSform:TIME:STATE
```

Type

Selects a band pass or low pass time domain transform. See [Chapter 5.7.5.2, "Band Pass and Low Pass Mode"](#), on page 194.

To calculate a low pass transform, the sweep points must be on a harmonic grid. Otherwise the analyzer can only calculate an approximate result and generates a warning. "Low Pass Settings..." opens a dialog that allows to establish or change a harmonic grid (not available for memory traces). See [Chapter 6.5.5.2, "Low Pass Settings Dialog"](#), on page 282.

Remote command:

```
CALCulate<Chn>:TRANSform:TIME[:TYPE]
CALCulate<Chn>:TRANSform:TIME:STIMulus
```

Impulse Response

Selects a window type which the R&S ZND uses to filter the trace in the frequency domain. The drop-down list shows the impulse response of a constant trace over a finite sweep range (i.e. a rectangular function) that was filtered using the different available window types. The selected window is applied to the active trace.

See also [Chapter 5.7.5.3, "Windows in the Frequency Domain"](#), on page 195.

Note: The frequency domain window is used to filter the trace before transforming it to the time domain. An independent "Time Gate" can be used after the transformation to eliminate unwanted responses (see [Chapter 6.5.6, "Time Gate Tab"](#), on page 284).

The analyzer always uses a "No Profiling (Rectangle)" window to calculate the time-gated frequency domain trace, see ["Time-Gated Frequency Domain Trace"](#) on page 198.

Remote command:

```
CALCulate<Chn>:TRANSform:TIME:WINDow
```

Side Lobe Level

Defines the side lobe suppression for an "Arbitrary Sidelobes (Dolph-Chebyshev)" window. The entered value is the ratio of the power of the central lobe to the power of the first side lobe in dB.

Remote command:

```
CALCulate<Chn>:TRANSform:TIME:DCHebyshev
```

Resolution Enh.

Broadens the frequency range that the analyzer considers for the time domain transform by a linear factor. A factor of 1 means that the original sweep range and the measured sweep points are used; no additional assumptions are made. With higher resolution enhancement factors, the measurement data is extrapolated using a linear prediction method. As a result, the resolution in time domain can be improved.

The ideal resolution enhancement factor depends on the properties of the DUT. For distance to fault measurements on cables, set it to 1.

Remote command:

```
CALCulate<Chn>:TRANSform:TIME:RESolution:EFACtor
```

TD-VSWR

Enables time domain site VSWR measurements (see [Chapter 5.7.5.6, "Time Domain \$S_{VSWR}\$ Measurements"](#), on page 199).

Remote command:

```
CALCulate:TDVSwr[:STATE]
```

Gate Span

[Time Domain \$S_{VSWR}\$ Measurements](#) relies on a time gate that is centered at the antenna's direct response (plus ring-down time), separating the direct response from the indirect responses (reflections).

"Gate Span" is equivalent to the "Span" value on the [Time Gate Tab](#).

This button is only enabled if [TD-VSWR](#) is active.

Remote command:

```
CALCulate<Chn>:FILTer[:GATE]:TIME:SPAN
```

Show Impulse Response...

To get an impression of the required [Gate Span](#), you can quickly create a trace displaying the impulse response of the active trace in a new diagram.

This button is only enabled if [TD-VSWR](#) is active.

6.5.5.2 Low Pass Settings Dialog

The "Low Pass Settings" dialog defines the harmonic grid for low pass time domain transforms.

Access: TRACE – [TRACE CONFIG] > "Time Domain" > "Low Pass Settings..."



Background information

Refer to [Chapter 5.7.5.4, "Harmonic Grid"](#), on page 195.

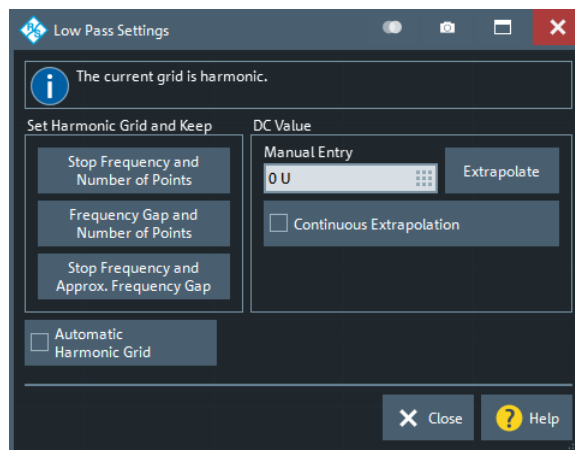

Is the Current Grid Harmonic?

The area at the top of the "Low Pass Settings" dialog indicates whether the current frequency grid is harmonic.

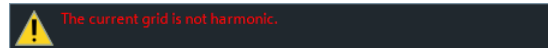

Remote command:

`[SENSe<Ch>:]HARMonic?`

Set Harmonic Grid and Keep

The three buttons provide alternative algorithms for calculation of a harmonic grid, based on the current sweep points.

- Keep "Stop Frequency and Number of Points" calculates a harmonic grid based on the current "Stop Frequency" (see ["Start Frequency / Stop Frequency / Center Frequency / Span Frequency"](#) on page 346) and the current number of sweep points (see ["Number of Points"](#) on page 353). This algorithm can increase the frequency gap (i.e. the [Freq Step Size](#)).
- Keep "Frequency Gap and Number of Points" calculates a harmonic grid based on the current "Stop Frequency" and the current frequency gap (i.e. the "Freq Step Size").
- Keep "Stop Frequency and Approximate Frequency Gap" calculates a harmonic grid based on the current "Stop Frequency", increasing the "Number of Points" in such a way that the frequency gap (i.e. the "Freq Step Size") remains approximately the same. This algorithm can increase the sweep time, due to the additional sweep points introduced.

The three grids can be calculated repeatedly in any order; the analyzer always starts from the original set of sweep points.

For more information, refer to [Chapter 5.7.5.4, "Harmonic Grid"](#), on page 195.

Remote command:

```
CALCulate<Chn>:TRANSform:TIME:LPASs
```

Automatic Harmonic Grid

If enabled (default) the frequency grid is automatically kept harmonic.

Remote command:

```
[SENSe<Ch>:]HARMonic:AUTO
```

DC Value

The control elements in this section define the measurement result at zero frequency and in the interpolation/extrapolation range between $f = 0$ and $f = f_{\min}$. They are enabled after a harmonic grid has been established.

Defining the low frequency sweep points

After calculating a harmonic grid, the analyzer must determine the value of the measured quantity at grid points below the analyzer's minimum frequency f_{\min} .

The following figure shows a scenario where the harmonic grid was calculated with fixed "Stop Frequency and Number of Points". The DC value and the values at the two additional red points must be extrapolated or interpolated according to the values at the measured sweep points (blue dots).

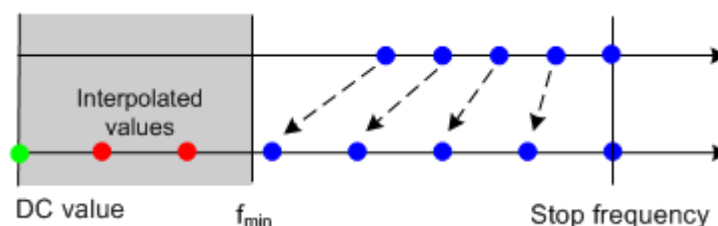

- If the properties of the DUT at $f = 0$ are sufficiently well known, then it is recommendable to enter the DC value manually ("Manual Entry").
Examples: At $f = 0$ the reflection factor of an open-ended cable is 1. It is -1 for a short-circuited cable and 0 for a cable with matched termination. If a cable with known termination is measured, enter these numbers as DC values.
- The "Extrapolate" button initiates an extrapolation of the measured trace towards $f = 0$ and overwrites the current DC value. This function can be used for a consistency check.
- "Continuous Extrapolation" initiates an extrapolation of the measured trace towards lower frequencies, so that the missing values (green and red dots) are obtained without any additional input. The extrapolation is repeated after each sweep.

After setting or extrapolating the DC value, the analyzer then calculates the remaining values (red dots) by linear interpolation of the magnitude and phase.

Remote command:

```
CALCulate<Chn>:TRANSform:TIME:LPASs:DCSParam
```

```
CALCulate<Chn>:TRANSform:TIME:LPASs:DCSParam:CONTinuous
```

```
CALCulate<Chn>:TRANSform:TIME:LPASs:DCSParam:EXTRapolate
CALCulate<Chn>:TRANSform:TIME:LPFRequency
```

6.5.6 Time Gate Tab

Defines and activates a gate in the time domain. An active time gate acts on the trace in time domain and in frequency domain representation. In time domain representation, you can use the time gate settings to eliminate unwanted responses in your signal. After switching back to the frequency domain, you will receive the frequency response of your DUT without the contribution of the unwanted responses. The time gate is independent of the frequency window used to filter the trace before transforming it to time domain.



Time domain analysis requires option R&S ZND-K2. If this option is not installed, the [Time Domain Tab](#) and "Time Gate" tabs are hidden.



Background information

Refer to [Chapter 5.7.5.5, "Time Gates"](#), on page 197.

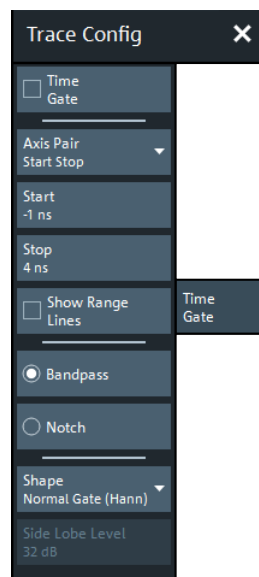

Time Gate

Enables or disables the time gate for the time domain and frequency domain traces. "Gat" is displayed in the trace list while the time gate is active.

```
Trc1 S21 dB Mag 10 dB/ Ref 0 dB Gat
```

Remote command:

```
CALCulate<Chn>:FILTer[:GATE]:TIME:STATe
```

Axis Pair

"Start Stop" lets you define the time gate via its "Start" and "Stop", "Center Span" lets you define it via its "Center" and "Span" value (in time). The analyzer generates a warning if the (resulting) time span exceeds the unambiguous range which is given by $\Delta t = 1/\Delta f$, where Δf is the "Freq Step Size". Simply reduce the time span until the warning disappears.

Remote command:

```
CALCulate<Chn>:FILTer[:GATE]:TIME:CENTer
```

```
CALCulate<Chn>:FILTer[:GATE]:TIME:SPAN
```

```
CALCulate<Chn>:FILTer[:GATE]:TIME:START
```

```
CALCulate<Chn>:FILTer[:GATE]:TIME:STOP
```

Show Range Lines

Displays or hides two red lines indicating the start and stop of the time gate in a time domain diagram.

Remote command:

```
CALCulate<Chn>:FILTer[:GATE]:TIME:SHOW
```

Bandpass / Notch

The filter type defines what happens to the data in the specific time region.

- A "Bandpass" filter passes all information in the specified time region and rejects everything else.
- A "Notch" filter rejects all information in the specified time region and passes everything else.

Remote command:

```
CALCulate<Chn>:FILTer[:GATE]:TIME[:TYPE]
```

Shape

Selects a gate shape which the R&S ZND uses to filter the trace in the time domain. The drop-down list visualizes how the time gate will affect a constant function after transformation back into the frequency domain. The selected window is applied to the active trace. The two red vertical lines represent the "Start" and "Stop" values defining the size of the time gate.

See also [Chapter 5.7.5.5, "Time Gates"](#), on page 197.

Remote command:

```
CALCulate<Chn>:FILTer[:GATE]:TIME:SHAPE
```

```
CALCulate<Chn>:FILTer[:GATE]:TIME:WINDOW
```

Side Lobe Level

Defines the side lobe suppression for an "Arbitrary Gate Shape (Dolph-Chebyshev)" gate. The entered value is the ratio of the power of the central lobe to the power of the first side lobe in dB.

Remote command:

```
CALCulate<Chn>:FILTer[:GATE]:TIME:DCHebyshev
```

6.5.7 Distance to Fault Tab

This tab is only visible, if option K3 is installed on the R&S ZND. It replicates the "Distance to Fault" tab of the "Distance to Fault" application. See [Chapter 6.15.2, "Distance to Fault Application"](#), on page 495.

6.5.8 Trace Statistics Tab

Evaluates statistical and phase information of the entire trace or of a specific evaluation range and calculates the x-dB compression point.

6.5.8.1 Controls on the Trace Statistics Tab

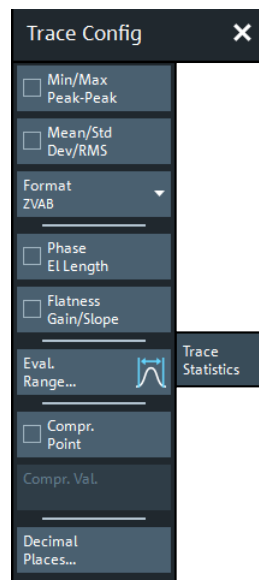

The "Evaluation Range..." button opens the "Evaluation Range" dialog (see [Chapter 6.5.8.2, "Evaluation Range Dialog"](#), on page 291).

The "Decimal Places..." button opens the "System Config" dialog to define the (maximum) number of fractional digits for setting values and measurement results. See also ["User Interface Tab"](#) on page 522..

Min/Max/Peak-Peak, Mean/Std Dev/RMS

The upper two softkeys in the "Trace Statistics" tab display or hide groups of statistical results. The values are based on all response values of the trace in the selected evaluation range ("Evaluation Range...").

Statistics (\$21)	
Min	-15.1576 dB
Max	-4.2206 dB
Pk-Pk	10.9370 dB
Mean	5.9004 dB
Std Dev	1.2777 dB
Rms	5.7588 dB

Suppose that the trace in the evaluation range contains n stimulus values x_i and n corresponding response values y_i (measurement points). The statistical values are obtained as follows:

- "Min" and "Max" are the largest and the smallest of all response values y_i .
- "Pk-Pk" is the peak-to-peak value and is equal to the difference "Max"–"Min"
- "Mean" is the arithmetic mean value of all response values:

$$Mean = \frac{1}{n} \sum_{i=1}^n y_i$$

- "Std Dev" is the standard deviation of all response values:

$$Std.Dev. = \sqrt{\frac{1}{n} \sum_{i=1}^n (y_i - \frac{1}{n} \sum_{i=1}^n y_i)^2}$$

- "RMS" is the root mean square (effective value) of all response values:

$$RMS = \sqrt{\frac{1}{n} \sum_{i=1}^n |y_i|^2}$$

Note: To calculate the "Min", "Max", "Pk-Pk" and the "Std Dev" values, the analyzer uses formatted response values y_i (see trace formats). Consequently, the mean value and the standard deviation of a trace depend on the selected trace format. In contrast, the "RMS" calculation is based on linear, unformatted values. The physical unit for unformatted wave quantities is 1 Volt. The RMS value has zero phase. The selected trace format is applied to the unformatted RMS value, which means that the RMS result of a trace does depend on the trace format.

Remote command:

```
CALCulate<Chn>:STATistics:MMPTpeak[:STATe]
CALCulate<Chn>:STATistics:MSTDdev[:STATe]
CALCulate<Chn>:STATistics:RMS[:STATe]
CALCulate<Chn>:STATistics:RESult?
CALCulate<Chn>:STATistics[:STATe]
CALCulate<Chn>:STATistics[:STATe]:AREA
```

Format

This setting determines how [Min/Max/Peak-Peak](#), [Mean/Std Dev/RMS](#) for complex-valued traces (Smith, Polar) are calculated:

- "ZVAB": the results are based on unformatted wave quantities (voltages)
- "R + jX": the results are based on the impedance values R and X
- "G + jB": the results are based on the admittance values G and B

In the two latter cases, the "RMS" value is not displayed.

Remote command:

```
CALCulate<Chn>:STATistics:FORMat
```

Phase/EI Length

Displays or hides the phase delay ("Phs Dly") and the electrical length ("EI Len") of the trace in the selected evaluation range ("Evaluation Range..."). The parameters are only available for trace formats that contain phase information, i.e. for the formats "Phase", "Unwr Phase", and the polar diagram formats "Polar", "Smith", "Inv Smith" (see [Chapter 6.3, "Format Softtool"](#), on page 252). Moreover, the sweep type must be a frequency sweep, and the evaluation range must contain at least 3 measurement points.

```
Statistics (S21)
Phs Dly 340.800 ps
EI Len 102.169 mm
```

The phase parameters are obtained from an approximation to the derivative of the phase in the selected evaluation range.

- "Phs Dly" is the phase delay, which is an approximation to the group delay and calculated as follows:

$$PD = -\frac{\Delta\phi_{deg}}{360^\circ \cdot \Delta f}$$

where Δf is the width of the evaluation range and $\Delta\Phi$ is the corresponding phase change. See also note on transmission and reflection parameters below.

- "EI Len" is the electrical length, which is the product of the phase delay times the speed of light in the vacuum.

If no dispersion occurs, the phase delay is equal to the group delay. For more information, refer to [Chapter 5.3.8, "Delay, Aperture, Electrical Length"](#), on page 121.

Note: To account for the propagation in both directions, delay and electrical length of a reflection parameter are only half the delay and electrical length of a transmission parameter. The formula for PD above is for transmission parameters. See the section on "Length and delay measurement" in [Chapter 5.6.1.3, "Auto Length"](#), on page 174.

Tip: The phase evaluation can cause misleading results if the evaluation range contains a 360 deg phase jump. The trace format "Unwr Phase" avoids this behavior.

Remote command:

```
CALCulate<Chn>:STATistics:EPDelay[:STATe]
CALCulate<Chn>:STATistics:RESult?
CALCulate<Chn>:STATistics[:STATe]
```

Flatness/Gain/Slope

Displays or hides trace parameters that the analyzer calculates for the selected evaluation range ("Evaluation Range...").

```
Statistics (S21)
Gain -5.1494 dB
Slope 0.6164 dB
Flatness 3.9478 dB
```

Suppose that A and B denote the trace points at the beginning and at the end of the evaluation range, respectively.

- "Gain" is the larger of the two stimulus values of points A and B.
- "Slope" is the difference of the stimulus values of point B minus point A.
- "Flatness" is a measure of the deviation of the trace in the evaluation range from linearity. The analyzer calculates the difference trace between the active trace and the straight line between points A and B. The flatness is the difference between the largest and the smallest response value of this difference trace.

Remote command:

```
CALCulate<Chn>:STATistics:SFLatness[:STATe]
CALCulate<Chn>:STATistics:RESult?
CALCulate<Chn>:STATistics[:STATe]
CALCulate<Chn>:STATistics[:STATe]:AREA
```

Compr. Point / Compr. Val.

Displays or hides all results related to the x dB (or x degrees) compression point of the trace, where x is the selected compression value. To obtain valid compression point results, a power sweep must be active, and the trace format must be dB or phase.

For dB traces, the x dB compression point of an S parameter or ratio is defined as the stimulus level where the response value has dropped by x dB compared to the response value at small stimulus signal levels ("small signal value"). For phase traces, the x degree compression point of an S parameter or ratio is defined as the stimulus level where the phase value has dropped by x° compared to the phase value at small stimulus signal levels. By default, the analyzer uses the value at the "First Point" of the selected evaluation range ("Evaluation Range...") as an approximation for the small signal value. However, you may also choose a different [Reference Value](#).

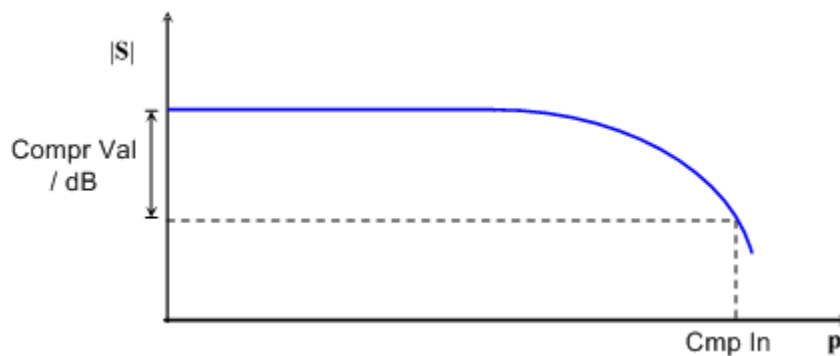

The compression point is a measure for the upper edge of the linearity range of a DUT. It is close to the highest input signal level for which the DUT shows a linear response, so that the magnitude of all S-parameters remains constant).

Statistics (S21)	Statistics (S21)
Cmp In -24.6907 dBm	Cmp In -24.9548 dBm
Cmp Out -35.3765 dBm	Cmp Out -116.29 °

- "Cmp In" is the stimulus level at the compression point in units of dBm. "Cmp In" always corresponds to the driving port level (e.g. the level from port no. j, if a transmission parameter S_{ij} is measured).
- For dB formatted traces, "Cmp Out" is the sum of the stimulus level "Cmp In" and the magnitude of the measured response value at the compression point. The magnitude of a transmission S-parameter S_{ij} is a measure for the attenuation (or gain) of the DUT, hence: "Cmp Out" = "Cmp In" + <Attenuation>. For phase formatted traces, "Cmp Out" is the response value at the compression point.

The info field shows invalid results ('----') if the wrong sweep type or trace format is selected, or if no compression point with the configured properties was found.

Remote command:

```
CALCulate<Chn>:STATistics:NLINear:COMP[:STATe]
CALCulate<Chn>:STATistics:NLINear:COMP:LEVel
CALCulate<Chn>:STATistics:NLINear:COMP:PHASe
CALCulate<Chn>:STATistics:NLINear:COMP:RESult?
CALCulate<Chn>:STATistics[:STATe]:AREA
```

Reference Value

This control is only available if [compression point](#) statistics are calculated. It selects the reference value ("small signal value") for the compression point calculation.

"First Point" (default)	uses the value at the first point of the selected evaluation range as the reference value (see Chapter 6.5.8.2, "Evaluation Range Dialog" , on page 291)
"Selected Marker"	uses the value at a selectable marker as the reference value (see "Selected Marker" on page 290)
"Range"	uses the average value in a configurable "Ref. Range" on page 290 as the reference value
"Defined Value"	allows to specify the reference value manually (see "Defined Value" on page 291)

Remote command:

```
CALCulate<Chn>:STATistics:NLINear:COMP:REFerence
```

Selected Marker

This button is only visible if "Selected Marker" is used as [Reference Value](#). It allows you to select the marker whose value shall be used as the reference ("small signal value") for the compression point calculation.

Remote command:

```
CALCulate<Chn>:STATistics:NLINear:COMP:RMARker
```

Ref. Range

This button is only visible if "Range" is used as [Reference Value](#).

It opens the "Reference Range" dialog that allows you to configure the sweep range whose average value shall be used as the reference ("small signal value") for the compression point calculation.

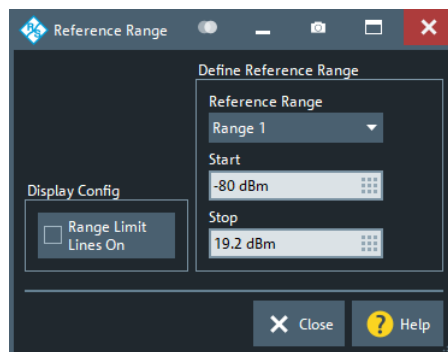

Remote command:

```
CALCulate<Chn>:STATistics:NLINear:COMP:RDOMain:USER
CALCulate<Chn>:STATistics:NLINear:COMP:RDOMain:USER:START
CALCulate<Chn>:STATistics:NLINear:COMP:RDOMain:USER:STOP
CALCulate<Chn>:STATistics:NLINear:COMP:RDOMain:USER:SHOW
```

Defined Value

This setting is only visible if "Defined Value" is used as [Reference Value](#). It manually defines the reference value ("small signal value") for the compression point calculation.

Remote command:

```
CALCulate<Chn>:STATistics:NLINear:COMP:RLEVel
CALCulate<Chn>:STATistics:NLINear:COMP:RPHase
```

6.5.8.2 Evaluation Range Dialog

The "Evaluation Range" dialog defines the range for various trace evaluation operations (trace statistics, offset, loss and fixture compensation calculations). The evaluation range is a continuous interval of the sweep variable.

Access:

- TRACE – [TRACE CONFIG] > "Trace Statistics" > "Evaluation Range..."
- CHANNEL – [OFFSET EMBED] > "Offset" > "Evaluation Range..."
- ...

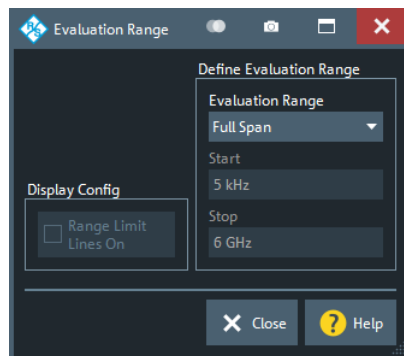

Evaluation Range

Selects a predefined evaluation range. Up to 10 different ranges are available for each recall set. "Full Span" means that the search range is equal to the entire sweep range. The trace statistics functions consider all measurement points with stimulus values x_i between the "Start" and "Stop" value of the evaluation range:

$$\text{"Start"} \leq x_i \leq \text{"Stop"}$$

The evaluation ranges are defined similar to the marker search ranges. For more information, see [Chapter 6.7.3.2, "Search Range Dialog"](#), on page 331.

Note: A restricted evaluation range is indicated in the "Trace Statistics" info field.

Statistics - (S2.1, Range 1)	
Min	-7.6453 dB
Max	-4.1692 dB
Pk-Pk	3.4761 dB

Remote command:

```
CALCulate<Chn>:STATistics:DOMain:USER
CALCulate<Chn>:STATistics:DOMain:USER:START
CALCulate<Chn>:STATistics:DOMain:USER:STOP
```

Range Limit Lines On

Displays or hides the range limit lines in the diagram area. Range limit lines are two vertical lines at the Start and Stop values of the active evaluation range ("Range 1" to "Range 10").

Remote command:

```
CALCulate<Chn>:STATistics:DOMain:USER:SHOW
```

6.5.9 Smooth Shift Hold Tab

Provides various functions to modify the entire measured trace.



- The analyzer can export the raw complex (unformatted) data or formatted data. The unformatted data are independent of all "Smooth Shift Hold" settings; see ["Formatted Values"](#) on page 301.
- For complex traces, if marker format and trace format do not coincide, the marker values are calculated before [Smoothing](#) and [Hold](#) are applied. In this case, the displayed marker values may not behave as expected.

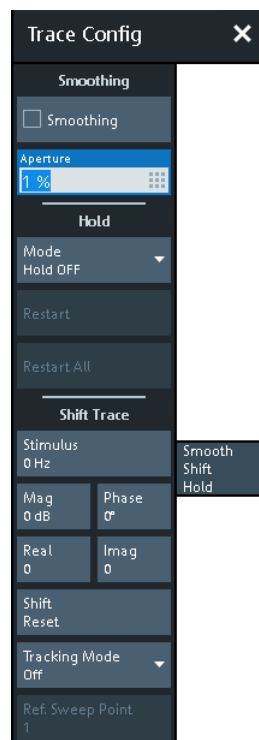

Smoothing

Activates the smoothing function for the active trace, which can be a data or a memory trace.

With smoothing active, the trace value at each sweep point is replaced by the arithmetic mean of the trace values at the sweep point itself, and at neighboring sweep points (symmetrically, to the left and to the right). The number of trace values to be averaged is defined by the [Aperture](#) and can be adjusted according to the properties of the trace.

Smoothing operates on the formatted trace and does not significantly increase the measurement time.

Tip: The sweep average is an alternative method of compensating for random effects on the trace by averaging consecutive traces. Compared to smoothing, the sweep average requires a longer measurement time but does not have the drawback of averaging out quick variations of the measured values.

See [Chapter 6.9.3, "Average Tab"](#), on page 350.

Remote command:

```
CALCulate<Chn>:SMOothing[:STATE]
```

Aperture

Defines how many trace values are averaged to smooth the trace if [Smoothing](#) is switched on.

An "Aperture" of a % means that the value at sweep point $n \in \{1, \dots, N\}$ is replaced by the arithmetic mean of the values at sweep points

$$\max \{ 1, \lfloor n - a/100 \cdot N/2 \rfloor \}, \dots, \min \{ N, \lfloor n + a/100 \cdot N/2 \rfloor \},$$

where N is the number of points of the sweep (or sweep segment for segmented sweeps).

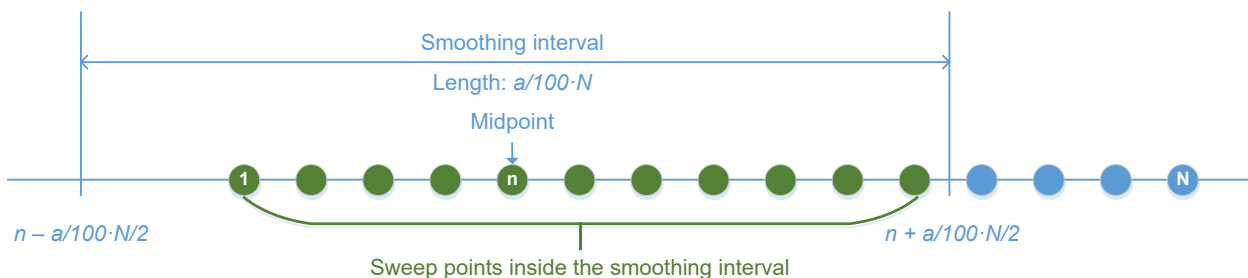

The range definition above takes border cases and rounding into account.

Tips: Finding the appropriate aperture

A large smoothing aperture enhances the smoothing effect but can hide quick variations of the measured values and thus produce misleading results.

To avoid errors, observe the following recommendations.

- Start with a small aperture and increase it only as long as you are certain that the trace is still correctly reproduced.
- Select a smoothing aperture that is small compared to the width of the observed structures (e.g. the resonance peaks of a filter). If necessary, restrict the sweep range or switch smoothing off to analyze narrow structures.

Remote command:

`CALCulate<Chn>:SMOothing:APERture`

Hold

Selects the "Max Hold" (peak hold) or "Min Hold" function for the active trace, or disables both functions ("Hold Off"). With enabled "Max Hold" or "Min Hold" function, the displayed trace shows the maximum or minimum values that the analyzer acquired since the start of the measurement. The "Max Hold" and "Min Hold" traces are real; they are based on the magnitude of the trace values (the phase values are discarded).

The "Hold" process can be restarted any time using "Restart" (current trace) or "Restart All" (all traces in the active recall set). The "Hold" process is also restarted automatically when the channel or trace settings are changed so that the previous measurement results are no longer compatible.

Note: A memory trace is unformatted by definition. Therefore, a "to memory" operation on a "Hold" trace actually stores the last measured trace data instead of the current "Max Hold" or "Min Hold" values.

Remote command:

`CALCulate<Chn>:PHOLd`

Shift Trace

Functions for shifting the active trace in horizontal and vertical direction.

Stimulus ← Shift Trace

Shifts the active trace in horizontal direction, leaving the positions of all markers unchanged. The unit of the offset value depends on the sweep type.

Note:

A "Stimulus" shift can be used in cartesian and in complex diagrams. The visible effect depends on the diagram type:

- In cartesian diagrams, the trace is shifted relative to the markers and the x-axis.
- In complex diagrams, the trace is not affected.

Remote command:

`DISPlay[:WINDow<Wnd>]:TRACe<WndTr>:X:OFFSet`

Mag / Phase / Real / Imag ← Shift Trace

Modifies the active trace by adding and/or multiplying complex constants.

The trace points are modified according to the following formula:

$$M_{new} = M_{old} \cdot 10^{<Magnitude>/20 \text{ dB}} a \cdot e^{j \cdot <Phase>/180^\circ} + <Real> + j <Imag>$$

The formula and the different constants are adjusted to the different display formats of a trace:

- The "Mag" factor shifts a dB Mag trace in vertical direction, leaving the phase of a complex parameter unchanged.
- The "Phase" factor rotates a trace that is displayed in a polar diagram around the origin, leaving the magnitude unchanged.
- The "Real" value shifts a real trace in vertical direction, leaving the imaginary part unchanged.

- The "Imag" value shifts an imaginary trace in vertical direction, leaving the real part unchanged.

Tip: Shifting the trace by constant values is a simple case of trace mathematics. Use the "User Def Math" dialog to define more complicated mathematical operations (see [Chapter 6.5.4.2, "User Def Math Dialog"](#), on page 275).

Remote command:

```
DISPlay[:WINDow<Wnd>]:TRACe<WndTr>:Y:OFFSet
```

Shift Reset

Resets the static shifting, defined using [Stimulus](#) and [Mag / Phase / Real / Imag](#), respectively.

Tracking Mode/Ref Sweep Point

Allows you to take the trace value at a selected sweep point as the reference point for a dynamic shift of the active trace.

With a raw complex trace value $z = \text{Re}(z) + j \cdot \text{Im}(z) = |z| e^{j \cdot \varphi(z)}$ and a raw complex value $z_r = \text{Re}(z_r) + j \cdot \text{Im}(z_r) = |z_r| e^{j \cdot \varphi(z_r)}$ at the reference point (for the current sweep), the dynamically shifted trace value $\text{Dyn_Shift}(z)$ is calculated as follows:

"Amplitude"	$\text{Dyn_Shift}(z) = z / z_r $
"Phase"	$\text{Dyn_Shift}(z) = z e^{-j \cdot \varphi(z_r)}$
"Real"	$\text{Dyn_Shift}(z) = z - \text{Re}(z_r)$
"Imag"	$\text{Dyn_Shift}(z) = z - \text{Im}(z_r)$
"Complex"	$\text{Dyn_Shift}(z) = z - z_r$

Remote command:

n.a.

6.5.10 Infinite Averaging Tab

The controls on the "Infinite Averaging" tab allow you configure infinite averaging for the active trace.

Infinite averaging means the average at a sweep point is taken over all trace values at this sweep point since the previous restart of the averaging cycle.

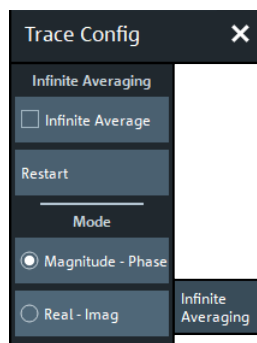

Infinite Average/Restart

"Infinite Average" enables or disables "Infinite Averaging " (default: disabled), "Restart" starts a new averaging cycle.

Remote command:

`CALCulate<Chn>:IAverage[:STATE]`

Mode

Selects the quantities to be averaged.

"Magnitude - Phase" Perform averaging of magnitude and phase (default) of the complex trace value.

Real - Imag Perform averaging of the real and imaginary part of the complex trace value (i.e. over the complex value itself).

Remote command:

`CALCulate<Chn>:IAverage:MODE`

6.5.11 Trace Data Tab

Stores one or several data or memory traces to a file or loads a memory trace from a file.

**Background information**

Refer to [Chapter 5.4.2, "Trace Files"](#), on page 129.

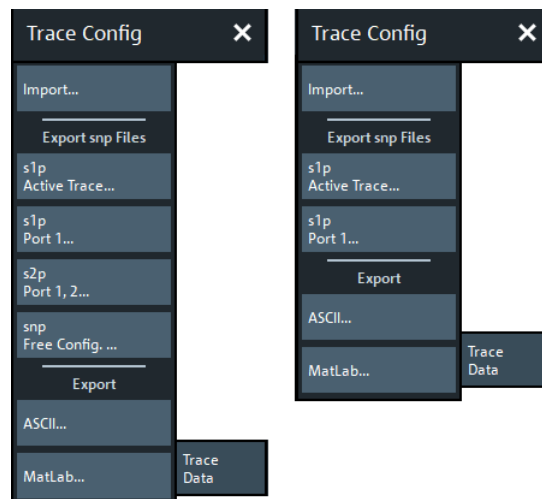

left = bidirectional R&S ZND

right = unidirectional R&S ZND

All buttons on the "Trace Data" tab serve as "openers" for related dialogs:

- "Import..." calls up a dialog to load a memory trace from a trace file; see [Chapter 6.5.11.1, "Import Complex Data Dialog"](#), on page 297.

- The buttons in the "Export snp Files" section call up a dialog to store data or memory traces to a trace file of the corresponding content and file format; see [Chapter 6.5.11.2, "Export Data - <File Type> Dialog"](#), on page 298
- "snp Free Config..." opens a dialog to define the port assignment for the created Touchstone (*.s<n>p) file. See [Chapter 6.5.11.4, "Select Ports Dialog"](#), on page 303.



For a unidirectional R&S ZND (see [Chapter 5.1.4.3, "R&S ZND: Unidirectional vs. Bidirectional Operation"](#), on page 75) S_{12} and S_{22} can not be measured and hence an export to s_{2p} is not available.

6.5.11.1 Import Complex Data Dialog

The "Import Complex Data" dialog loads a memory trace from a trace file. Trace files are ASCII files with selectable file format. The loaded trace data is used to generate a memory trace which is coupled to the active data trace.

Access: TRACE – [TRACE CONFIG] > "Trace Data" > "Import..."



Background information

Refer to [Chapter 5.4.2, "Trace Files"](#), on page 129.

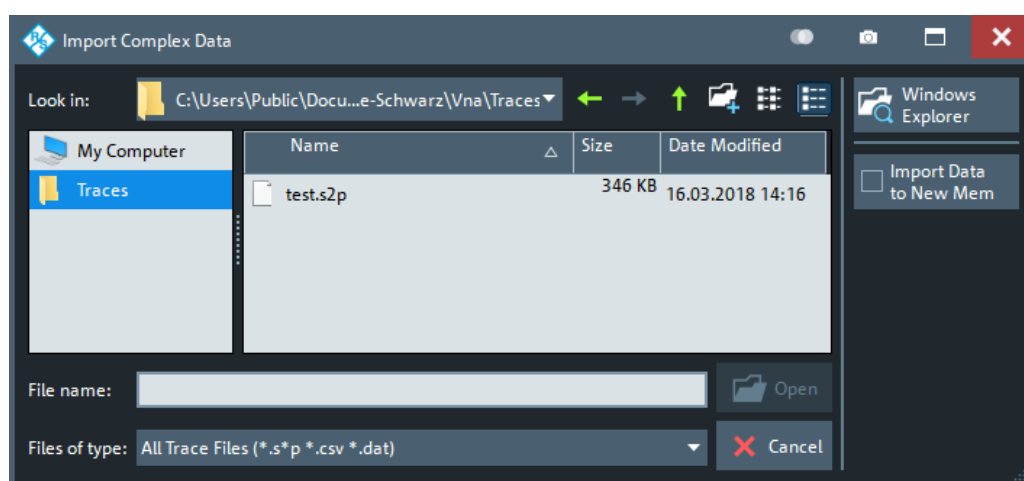

On loading data from a trace file with several traces, the analyzer displays a dialog to select one or more of the traces stored in the file (see [Chapter 6.5.11.3, "Select Parameter Dialog"](#), on page 302). E.g., for an *.s_{2p} Touchstone file, the box offers all four 2-port S-parameters (see [Chapter 5.4.2.1, "Touchstone Files"](#), on page 130).

Coupling between the imported memory trace and the active data trace implies that the stimulus values of the imported data and of the active trace must be compatible. Compatibility means that the "Sweep Type" of the two traces must match; the position and number of the sweep points do not have to be the same.

The analyzer checks for compatibility before importing data. The "Select Parameter" box remains empty if the selected file contains no compatible data.

"Import Complex Data" is a standard "Open File" dialog with an additional button.

Import Data to New Mem

Specifies whether the loaded data overwrite an existing memory trace, if available (box unchecked), or whether they are used to generate a new memory trace (box checked).

If the box is unchecked and the active trace is a memory trace, then this memory trace will be overwritten. If the box is unchecked and the active trace is a data trace, then the data trace's last created memory trace will be overwritten (or a new memory trace will be created, in case there was previously no memory trace assigned to this data trace).

Remote command:

`MMEMoRY:LOAD:TRACe`

6.5.11.2 Export Data - <File Type> Dialog

The "Export Data - <File Type>" dialog stores data or memory traces to a trace file. Trace files are ASCII files with selectable file format.

Access:

- TRACE – [TRACE CONFIG] > "Trace Data" > "Export snp Files" – ...
- TRACE – [TRACE CONFIG] > "Trace Data" > "Export" – ...

Data export can serve many purposes, e.g.:

- To process and evaluate measurement data in an external application.
- To store measurement data and reimport it in a future measurement session.



Background information

Refer to the following sections:

- [Chapter 5.4.2, "Trace Files"](#), on page 129.
- [Chapter 5.4.2.3, "Finding the Best File Format"](#), on page 138

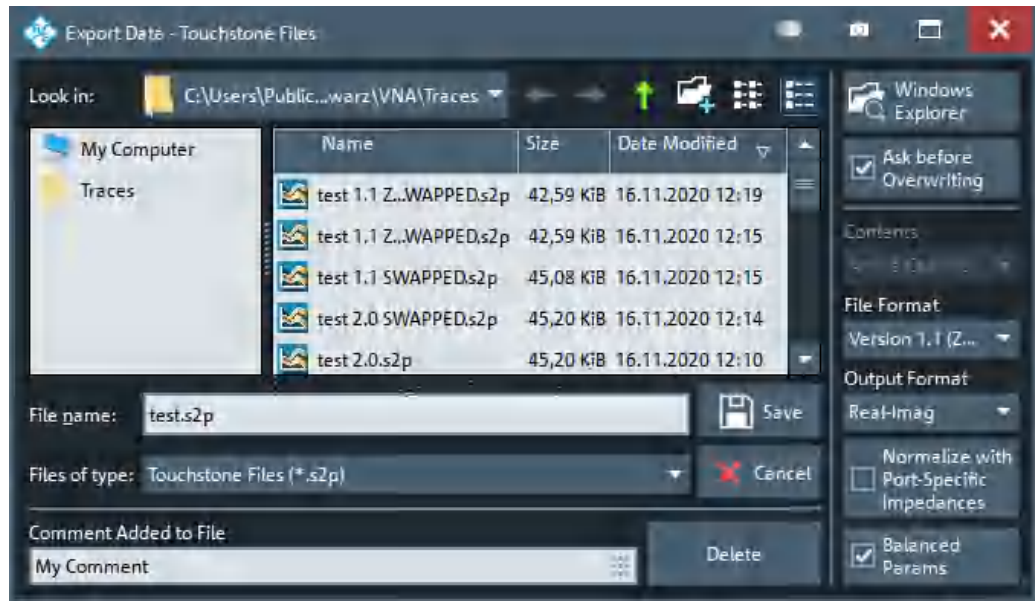

Figure 6-2: Touchstone file export

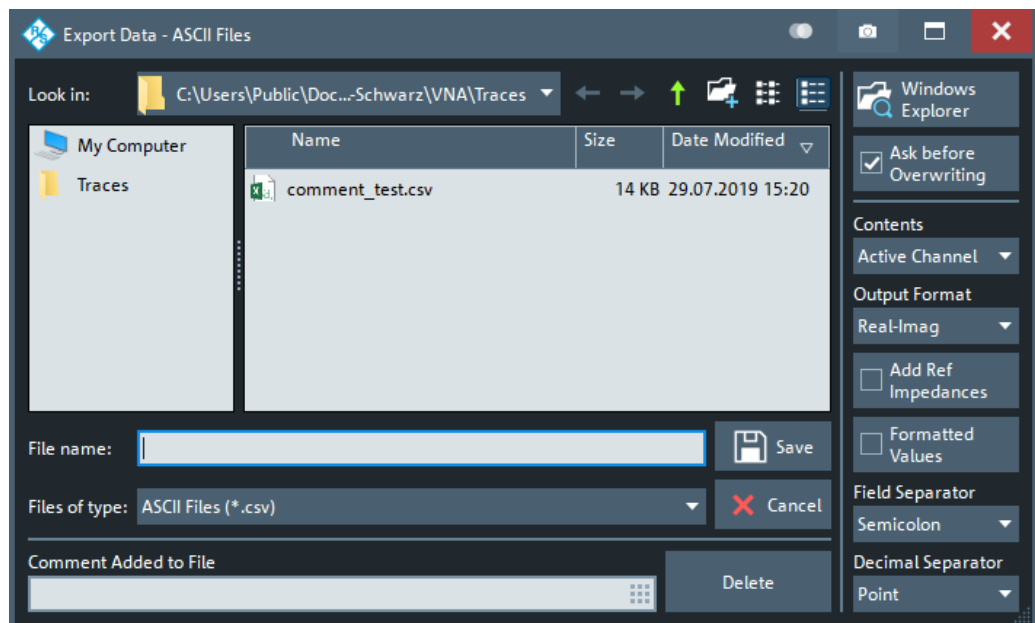

Figure 6-3: ASCII Trace files export



For a unidirectional R&S ZND, export to `s2p` is not available.

The "Export Data - <File Type>" dialog is a standard "Save File" dialog with several additional buttons to specify the export options. Many options depend on the selected export file format ("Files of type"). The displayed controls change accordingly.

The export options are remembered when the dialog is closed.

Ask Before Overwriting

Activates a message box to be displayed before an older trace file with the same file name and directory is overwritten.

Contents

For ASCII (*.csv) and Matlab (*.dat) export, you can include the active trace, all traces of the active channel (including memory traces), or all traces in all channels.

For Touchstone file export, it is possible to export the traces of the active channel or of all channels. Consider "[Conditions for Touchstone File Export](#)" on page 136.

In both cases, the R&S ZND creates one file per channel.

File Format

Selects the Touchstone file format to be generated. See [Chapter 5.4.2.1, "Touchstone Files"](#), on page 130.

Remote command:

`MMEMoRy:STORe:TRACe:OPTion:FORMat`

Output Format

Selects the format of the exported raw, complex measurement values. The exported values can be represented by the real and imaginary parts, the linear magnitude and phase, or dB magnitude and phase; see also "[Formatted Values](#)" on page 301.

Export of [Formatted Values](#) is not available for Touchstone files.

Normalize with Port-Specific Impedances

For Touchstone file export only. If checked, the firmware renormalizes the exported S-parameters according to the port-specific reference impedances instead of a common target impedance of 50 Ω (see "[Renormalization of S-Parameters](#)" on page 136).

Note however, that during import the firmware always assumes a common reference impedance of 50 Ω .

Balanced Params

For Touchstone file export only: activates/deactivates the export of balanced (and mixed-mode) S-parameters.

Note:

- Please consider "[Conditions for Touchstone File Export](#)" on page 136. In particular: if only one port of a balanced port is selected, then the export fails.
- In contrast to single-ended S-parameters, balanced S-parameters are always normalized.

Remote command:

`MMEMoRy:STORe:TRACe:OPTion:BALanced`

Decimal Places

Opens a dialog that allows you to specify the number of decimal places for stimulus and data values in all supported trace data files (Touchstone, ASCII, MatLab).

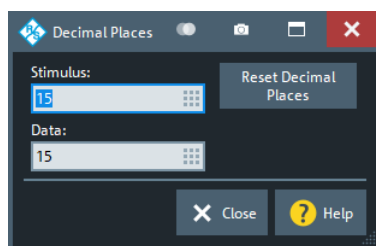

The allowed range is 1 (minimum precision) to 15 (maximum precision). "Reset Decimal Places" resets these numbers to their respective defaults, which is 15 in both cases.

Note: In the current implementation of the Touchstone file export, only the "Version 1.1 (ZNx)" [File Format](#) file format supports independent settings for stimulus and data values. For the "Version 1.1" and "Version 2.0" formats the "Data" number of digits is used for both stimulus and data values.

Remote command:

`MMEMory:STORe:TRACe:OPTion:DECimals:STIMulus`

`MMEMory:STORe:TRACe:OPTion:DECimals:DATA`

Add Ref Impedances

For ASCII (*.csv) or Matlab (*.dat) files only: Includes the reference impedances Z_0 for all analyzer ports in the file header.

Formatted Values

For ASCII (*.csv) or Matlab (*.dat) files only: Selects the format for the exported trace data.

- Check box cleared (off):** Export the raw complex (unformatted) measurement values, represented by the real and imaginary parts, the linear magnitude and phase, or dB magnitude and phase.

The exported complex trace values are the values at the beginning of the trace data flow. None of the following stages (trace mathematics, shift, time domain gate, trace formatting and smoothing) affects the exported data. "Save" writes the raw stimulus values (frequency/power/time, according to the sweep type) and the raw, complex measurement points to a file. See [Chapter 5.1.5, "Data Flow"](#), on page 77. Export of complex data is available for all trace file types.
- Check box selected (on):** Export the values as they are displayed in the diagram, e.g. export the dB magnitude, if trace format "dB Mag" is selected. The trace file does not necessarily contain the full (complex) information about the trace. For trace formats involving Cartesian diagrams ("dB Mag", "Real", "Imag"...), the stimulus value and a single real response value is exported. For circular diagrams, both the real and imaginary part of the response value is exported.

The trace values are the fully processed values as they appear in the diagram area. They correspond to the results in the marker info field. All possible stages of the trace data flow (e.g. trace formats, trace mathematics, time domain transform, shift, smoothing) are considered. Some trace functions (e.g. time scale, shift stimulus) also affect the stimulus values.

Export of formatted data is not available for Touchstone files.

Field Separator

For ASCII (*.csv) and Matlab (*.dat) export only: defines the separator the analyzer uses to separate different numbers in each line of the file.

Decimal Separator

For ASCII (*.csv) files only: Selects either the "Point" or the "Comma" (if needed to process the exported data with an external application) as a separator for decimal numbers.

Save

Stores the trace data, according to the selected options.

Tip: Note the conditions described in ["Conditions for Touchstone File Export"](#) on page 136.

Remote command:

`MMEMoRY:STORe:TRACe:PORTs`

`MMEMoRY:STORe:TRACe`

`MMEMoRY:STORe:TRACe:CHANnel`

Comment Added to File

Defines a comment to be added to the exported trace data file.

If empty (←"Delete"), no comment is added.

Remote command:

`MMEMoRY:STORe:TRACe:OPTion:COMMeNt`

6.5.11.3 Select Parameter Dialog

The "Select Parameter" dialog provides a selection of measurement results (e.g. S-parameters) or traces, e.g. for trace import, import of power correction coefficients, limit line import.

Access: The dialog may be called from several dialogs, for example on pressing "Open" in the [Import Complex Data Dialog](#).

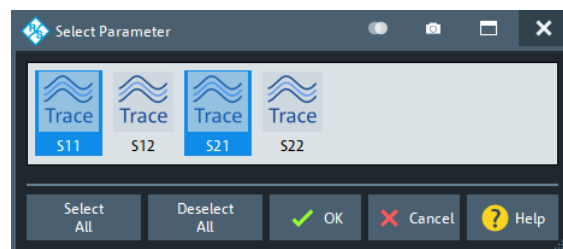
**Select All / Deselect All**

During trace data import, selects/deselects all traces contained in the opened trace file.

Auto Distribute

Available for trace data import only.

If checked, a selected trace S_{ij} is imported as a memory trace for all data traces in the current recall set that are measuring S_{ij} .

Remote command:

`MMEMoRY:LOAD:TRACe:AUTO`

6.5.11.4 Select Ports Dialog

The "Select Ports" dialog defines the port assignment for the created Touchstone (*.s<n>p) file.

Access: TRACE – [TRACE CONFIG] > "Trace Data" > "snp Free Config..."



Touchstone files and file export

Note the conditions described in "[Conditions for Touchstone File Export](#)" on page 136.

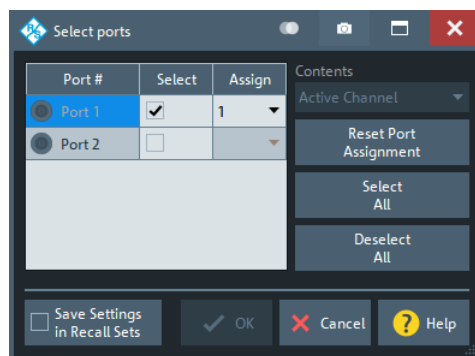

Checks and Messages in the Dialog

After each port or channel selection, the R&S ZND checks the channel data for compatibility with the trace export conditions. If data from "All Channels" are exported, every channel must contain a compatible set of traces; see "[Conditions for Touchstone File Export](#)" on page 136.

The "OK" button is available only if no error message is displayed in the dialog.

Select / Select All / Deselect All

Selects the ports to be considered for the S-parameter export.

Example: With ports 1 and 2 selected, S-parameters S_{11} , S_{12} , S_{21} and S_{22} are exported.

Remote command:

`MMEMoRY:STORe:TRACe:PORTs`

Assign

Selects the port number assignment in the created *.s<n>p file. By default, analyzer and *.s<n>p port numbers are identical. You can interchange the port assignment to change the order of the S-parameters in the created Touchstone file. Each of the analyzer port numbers must be assigned to one *.s<n>p port number.

Active Channel / All Channels

Selects data export for the active channel or for all channels.

Reset Port Assignments

Restores the identity between original and assigned port number.

Save Settings in Recall Set

The "Select Ports" dialog preserves the selected and assigned port numbers. By default (unchecked), these settings are global, i.e. they are identical for each recall set and are not affected by a [PRESET]. However you can also choose to preserve specific settings for the current recall set (checked).

Note however that the settings are not persisted unless the "Select Ports" dialog is closed using "OK".

6.6 Lines Softtool

The "Lines" softtool allows you to define limits for the measurement results, visualize them in the diagrams and activate/deactivate the limit check. The analyzer provides upper, lower, ripple and circle limits. In addition, the "Lines" softtool provides functions to limit complex diagrams to a user-defined "Display Circle" and to add user-defined horizontal lines to cartesian diagrams.

Access: TRACE – [LINE] hardkey

**Background information**

Refer to [Chapter 5.4.1, "Limit Check"](#), on page 122.

6.6.1 Limit Test Tab

Defines limit lines for the measurement results (upper and lower limits), visualizes them in the diagrams and activates/deactivates the limit check.

Limit lines are available for all cartesian diagram types; "dB Mag" limits can also be checked in complex diagrams (Smith, Polar).

**Background information**

Refer to [Chapter 5.4.1, "Limit Check"](#), on page 122.

6.6.1.1 Controls on the Limit Test Tab

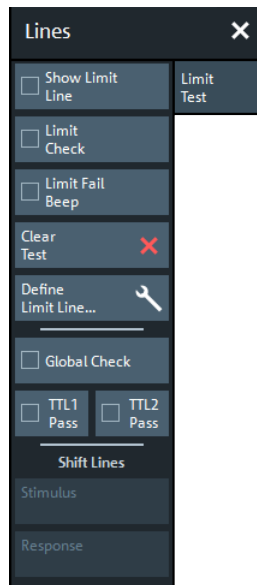

The "Define Limit Line..." button opens the "Define Limit Lines" dialog (see [Chapter 6.6.1.2, "Define Limit Lines Dialog"](#), on page 308).

Show Limit Line

Shows or hides the limit line associated with the active trace in a Cartesian diagram area.

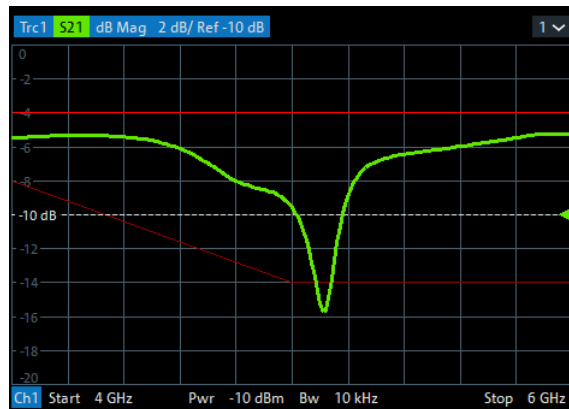

The limit line colors are defined in the [Define User Color Scheme Dialog](#) (SYSTEM > [DISPLAY] > "Config" > "Define User Color..."). You can choose between various options:

- Display upper and lower limit lines with different colors.
- Assign the same color to traces and associated limit lines.
- Assign different colors to limit line segments with disabled limit check.

Note: Display of the limit line and limit check are independent of each other: Hiding the limit line does not switch off the limit check.

Remote command:

```
CALCulate<Chn>:LIMit:DISPlay[:STATe]
```

Limit Check

Enables/disables the limit check for the active trace.

If enabled, an additional info field is displayed in the diagram, indicating the "PASS" or "FAIL" state. Limit violations are marked with a colored square. An acoustic signal ([Limit Fail Beep](#)) and a TTL signal indicating pass or fail can be generated in addition.

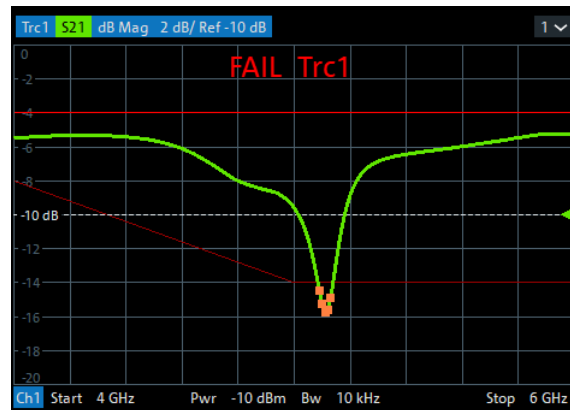

The "Limit Fail Trace Color" and the appearance of the limit fail symbols are defined in the [Define User Color Scheme Dialog](#) ("Display" > "Config" > "Define User Color...").

Note:

- Limit check and display of limit lines are independent of each other:
 - The limit lines can be displayed, no matter if the limit check is enabled.
 - If "Limit Check" is enabled, the limits are checked, no matter if the limit lines are displayed.
 - The limit check can even be enabled, if no limit lines are defined. In this case, the info field displays "No limit defined!" and the limit check always passes.
- Limit lines are defined for a particular trace format. However, the limit check is performed irrespective of the current trace format. The info field indicates the correct "PASS"/"FAIL" state and limit violations are visualized on the trace (if any).

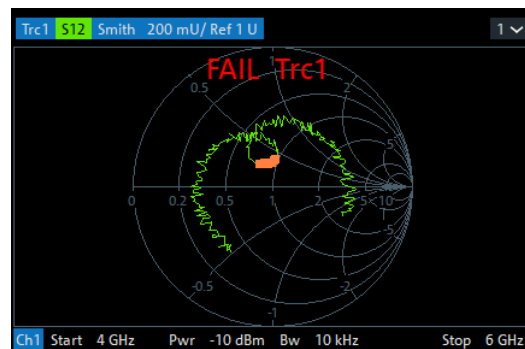

Figure 6-4: Limit line violations in complex trace formats

Remote command:

```
CALCulate<Chn>:LIMit:STATe
CALCulate<Chn>:LIMit:LOWer:STATe
CALCulate<Chn>:LIMit:UPPer:STATe
CALCulate<Chn>:LIMit:FAIL?
```

```
CALCulate:LIMit:FAIL:ALL?
CALCulate<Chn>:LIMit:STATe:AREA
```

Limit Fail Beep

Activates or deactivates the fail beep. The fail beep is a low-tone acoustic signal that is generated each time the analyzer detects an exceeded limit. No fail beep can be generated if the limit check is switched off.

These sounds are generated using the built-in sound chip and loudspeaker of the R&S ZND.

Remote command:

```
CALCulate<Chn>:LIMit:SOUNd[:STATe]
```

Clear Test

Resets the limit check results.

Remote command:

```
CALCulate<Chn>:LIMit:CLEar
```

Global Check

Activates or deactivates the global limit check including upper/lower limits and ripple limits. The global limit check is a composite limit check over all traces of the current recall set. The result of the global check appears in a popup box whenever "Global Check" is selected.

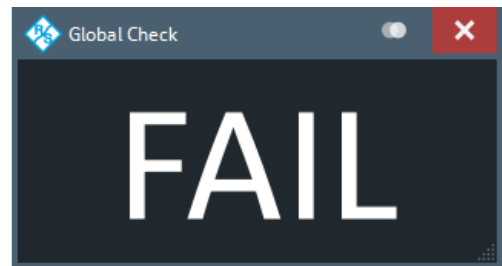
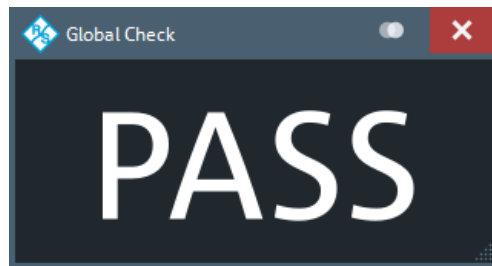

- "PASS" represents pass for all traces with enabled limit check. A trace without limit lines or with disabled individual limit check always passes the global check.
- "FAIL" means that the limit check for one or more traces failed.

Remote command:

```
CALCulate:CLIMits:FAIL?
```

TTL1 Pass / TTL2 Pass

Assigns the active trace to the low-voltage (3.3 V) TTL output signals at the USER PORT (see [Chapter 11.3.1.1, "USER PORT"](#), on page 1156).

Monitoring a single trace

If "TTL1 Pass" ("TTL2 Pass") is selected and the trace passes all active limit checks, then the TTL signal is applied to pin 13 (pin 14) of the USER PORT. If one of the limit checks fails, then no TTL signal is generated.

Monitoring several traces

If a channel contains several traces, is possible to assign each of them to any TTL output. The assignment divides the traces of the channel into four groups:

- not assigned to signal 1 or signal 2
- assigned to signal 1, but not to signal 2
- assigned to signal 2, but not to signal 1
- assigned to both signals

If several traces are assigned to a pass/fail signal, then the TTL signal is only generated if all traces are within their respective limits. It is switched off if one trace exceeds those limits.

Application: Graduated quality check

The two pass/fail signals can be used to distinguish three quality levels of a DUT. The test is performed on two identical traces Trc1 and Trc2 within the same channel. Trc1 is configured with a tighter, Trc2 with a looser set of limit lines. For Trc1 "TTL1 Pass" is enabled, for Trc2 "TTL2 Pass".

- TTL1: signal
If Trc1 passes (and so does Trc2), the quality of the DUT is good.
- TTL1: no signal, TTL2: signal
If Trc1 fails but Trc2 passes, the quality of the DUT is still sufficient.
- TTL1: no signal, TTL2: no signal
If both Trc1 and Trc2 fail, the quality is poor.

Instead of using two traces, it is possible to consider two groups of traces that are assigned to "TTL1 Pass" and "TTL2 Pass", respectively.

Note: Default values "TTL1 Pass" / "TTL2 Pass" for new traces can be set in the "Advanced" tab of the "System Config" dialog (see ["TTL Pass Default Values"](#) on page 528).

Remote command:

```
CALCulate<Chn>:LIMit:TTLout<Pt>[:STATe]
```

Shift Lines

By setting the "Stimulus" and "Response" values it is possible to shift a previously defined limit line in x and y direction, respectively, without having to redefine the constituent line segments.

Remote command:

```
CALCulate<Chn>:LIMit:CONTRol:SHIFt
```

```
CALCulate<Chn>:LIMit:UPPer:SHIFt
```

```
CALCulate<Chn>:LIMit:LOWer:SHIFt
```

6.6.1.2 Define Limit Lines Dialog

The "Define Limit Lines" dialog defines the limit lines for the active trace on a segment-by-segment basis. For each segment, the limit is defined as a line connecting two points (with linear or logarithmic "Interpolation"), or as a user-defined formula.

Access: TRACE – [LINE] > "Limit Test" > "Define Limit Line..."



Background information

Refer to [Chapter 5.4.1, "Limit Check"](#), on page 122.

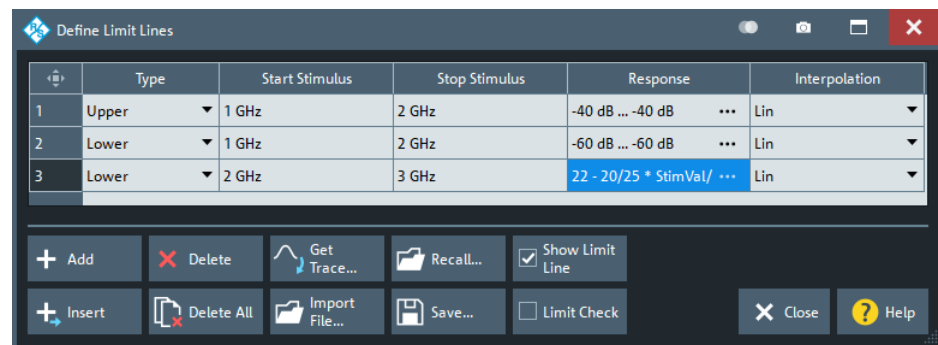

When you switch to a different [sweep type](#), existing limit lines are preserved. With a different sweep variable, however, the limit lines cannot be [displayed](#) and the corresponding [limit check](#) cannot be executed.

If you want to define limit lines for the new sweep variable, you first have to [delete all](#) existing limit lines for the old sweep variable.

Controls on the Define Limit Lines Dialog

The "Define Limit Lines" dialog contains a table to edit the individual segments of the limit lines. The buttons below the table extend or shorten the segment list.



Creating limit lines with minimum effort

Choose one of the following methods to create and handle limit lines efficiently:

- To define limit lines with only a few segments, select "Add" and edit each segment in the [Segment List](#) individually.
- Select a data or memory trace as a limit line ("Import Trace...") or import a trace stored in a file ("Import File...").
- Save your limit lines to a file so you can reuse or modify them later sessions ("Save Limit Line...", "Recall Limit Line...").

Segment List

Defines the individual limit line segments.

The table contains an automatically assigned current number for each segment plus the following editable columns:

- "Type" indicates whether the segment belongs to an "Upper" or a "Lower" limit line, or if the limit check at the segment is switched "Off". Switching off the limit check does not delete the segment but changes its screen color.
- "Start Stimulus" is the stimulus (x-axis) value of the first point of the segment.
- "Stop Stimulus" is the stimulus (x-axis) value of the last point of the segment.
- "Response"
 - For a limit line segment that is defined as linear functions of the stimulus, "Response" displays the y-axis values at the start and stop stimulus (x-axis) values.
 - For formula-defined line segments, it displays the formula.

Tap the "Response" field to open the [Response Dialog](#) that offers the full range of configuration possibilities.

- "Interpolation" determines whether the limit line segment is interpolated linearly or logarithmically. The latter is possibly more suitable for logarithmic sweeps.

Remote command:

```
CALCulate<Chn>:LIMit:SEGMENT:COUNT?
CALCulate<Chn>:LIMit:SEGMENT<Seg>:TYPE
CALCulate<Chn>:LIMit:SEGMENT<Seg>:STIMulus:START
CALCulate<Chn>:LIMit:SEGMENT<Seg>:STIMulus:STOP
CALCulate<Chn>:LIMit:SEGMENT<Seg>:AMPLitude:START
CALCulate<Chn>:LIMit:SEGMENT<Seg>:AMPLitude:STOP
CALCulate<Chn>:LIMit:CONTROL[:DATA]
CALCulate<Chn>:LIMit:CONTROL:SHIFT
CALCulate<Chn>:LIMit:DATA
CALCulate<Chn>:LIMit:LOWER[:DATA]
CALCulate<Chn>:LIMit:LOWER:SHIFT
CALCulate<Chn>:LIMit:UPPER[:DATA]
CALCulate<Chn>:LIMit:UPPER:FEED
CALCulate<Chn>:LIMit:SEGMENT<Seg>:INTERpol
```

Add / Insert / Delete / Delete All

The first four buttons below the segment list extend or shorten the list. The analyzer places no restriction on the number of segments in a limit line.

- "Add" adds a new segment to the end of the list. The new segment extends from the "Stop Stimulus" value of the last segment to the end of the sweep range. Its response values are equal to the "Stop Response" value of the last segment.
- "Insert" adds a new segment before the active segment (marked by a blue background in the first column of the segment list). The new segment extends from the "Stop Stimulus" value of the segment before the active segment to the "Start Stimulus" value of the active segment. Its response values are equal to the "Start Response" value of the active segment. The segment numbers in the list are adapted.
If no segment is active, "Insert" is equivalent to "Add".
- "Delete" removes the selected segment from the list.
- "Delete All" clears the entire segment list so it is possible to define or load a new limit line.

Remote command:

```
CALCulate<Chn>:LIMit:DELeTe:ALL
```

Recall... / Save...

The buttons open an Open File" or "Save File" dialog, which allows you to load a limit line from a limit line file or store the current limit line configuration to a limit line file.

A limit line file (*.limit) is a text file whose content describes a limit line configuration. See [Chapter 5.4.1.4, "File Format for Limit Lines"](#), on page 128.

Remote command:

```
MMEMOry:LOAD:LIMit
MMEMOry:STORe:LIMit
```

Get Trace... / Import File...

- "Get Trace..." opens a dialog to load a limit line from a data or memory trace in the active recall set.

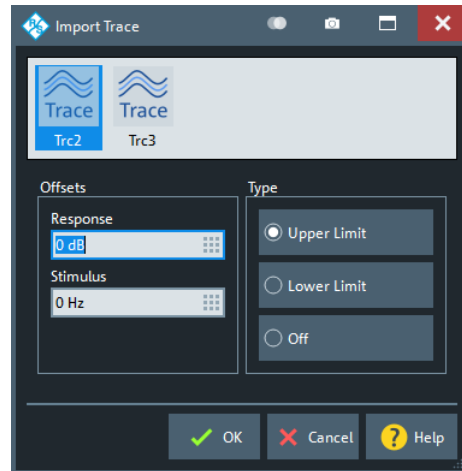

The active trace must be cartesian and the "Format" of the imported trace must be the same as the "Format" of the active trace.

- "Import File..." opens a dialog to load a limit line from a trace file (see [Chapter 6.5.11, "Trace Data Tab"](#), on page 296).

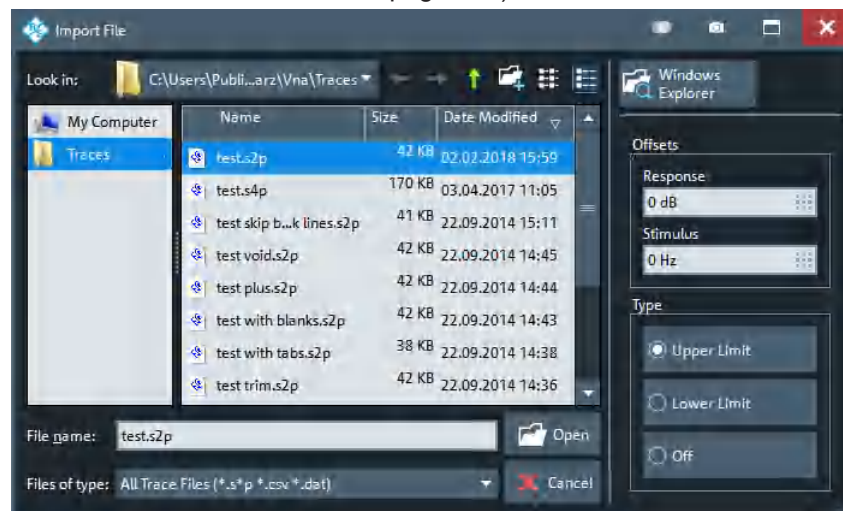

In case the selected file contains more than one trace, another popup dialog lets you select the adequate one:

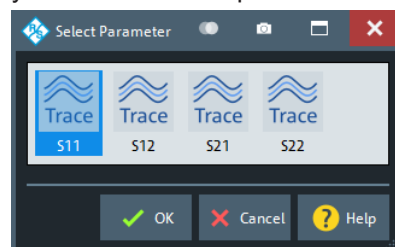

Imported traces are polygonal curves with n points and $n - 1$, where n is the "Number of Points" of the imported trace (see [Chapter 6.10.1, "Sweep Params Tab"](#), on page 352). The $n - 1$ segments are appended to the current segment table for further editing. Existing limit line segments are not overwritten.

Both import dialogs contain the following file import settings:

- "Offsets" contains two input fields to define constant offset values for all imported segments. The "Response" offset shifts all segments in vertical direction, the "Stimulus" offset shifts them in horizontal direction. The offsets are added to the start and stop values of all segments.
- "Type" defines whether the imported segments belong to the "Upper" or "Lower" limit line. A third option is to import the segments but disable the limit check ("Off").

Remote command:

```
CALCulate<Chn>:LIMit:LOWer:FEED
```

```
CALCulate<Chn>:LIMit:UPPer:FEED
```

Response Dialog

The "Response" dialog allows you to configure the limit line segment in detail.

Access: [Define Limit Lines Dialog](#) > "Response" cells

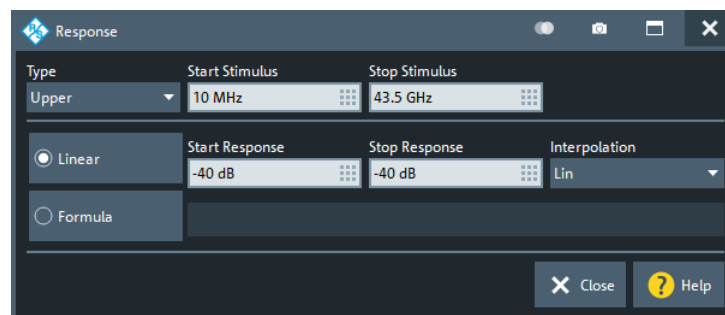

For convenience, "Type", "Start Stimulus", "Stop Stimulus", and "Interpolation" are repeated from the [Segment List](#) of the "Define Limit Lines" dialog.

Linear/Formula

Allows you to decide how to define the line segment.

- "Linear": Define the line segment as a straight line, connecting the endpoints ("Start Stimulus", "Start Response") and ("Stop Stimulus", "Stop Response"). In this case, you can also decide whether linear or logarithmic [interpolation](#) is used.
- "Formula": Define the line segment by a custom formula. You can enter the formula in the text field to the right of the "Formula" button, or Tap and hold the text field to open the [User Def Math Dialog](#).

Remote command:

```
CALCulate<Chn>:LIMit:SEGment<Seg>:FORMula:STATe
```

```
CALCulate<Chn>:LIMit:SEGment<Seg>:FORMula
```

6.6.2 Ripple Test Tab

Defines ripple limits for the measurement results, visualizes them in the diagrams and activates/deactivates the ripple limit check.

A ripple test is a special type of limit test where the **difference** between response values in certain stimulus ranges must not exceed configurable limits (ripple limits).

Ripple limits can be defined for cartesian trace formats only and are limited to the trace format they were configured for. If another format is selected, the ripple limit lines are hidden and the limit check is temporarily disabled.



Background information

Refer to [Chapter 5.4.1, "Limit Check"](#), on page 122.

6.6.2.1 Controls on the Ripple Test Tab

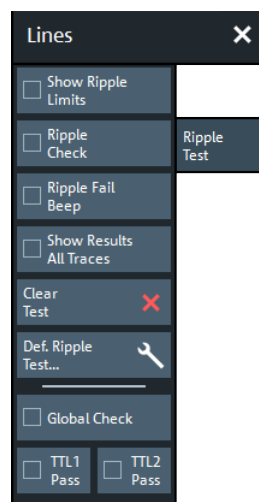

The "Def. Ripple Test..." button opens the "Define Ripple Test" dialog (see [Chapter 6.6.2.2, "Define Ripple Test Dialog"](#), on page 315).

Show Ripple Limits

Shows or hides the ripple limit lines associated with the active trace in a Cartesian diagram area. The vertical positions of the ripple lines are recalculated after each sweep; only their stimulus range and distance (the ripple limit) are fixed.

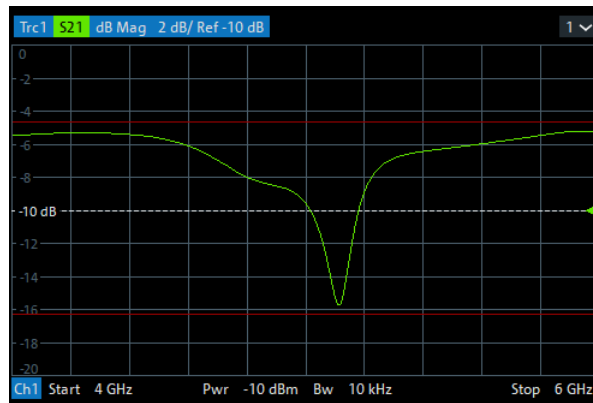

Note: Display of the limit line and limit check are independent of each other: Hiding the limit line does not switch off the limit check.

Remote command:

`CALCulate<Chn>:RIPple:DISPlay[:STATe]`

Ripple Check

Switches the ripple limit check of the active trace on or off.

When the limit check is switched on, a movable info field shows the pass/fail information and the measured ripple in each ripple limit range. If the ripple limit check fails at a measurement point, the point is marked with a colored square.

The "Limit Fail Trace Color" is defined in the [Define User Color Scheme Dialog](#).

An acoustic signal ([Ripple Fail Beep](#)) and a TTL signal indicating pass or fail can be generated in addition.

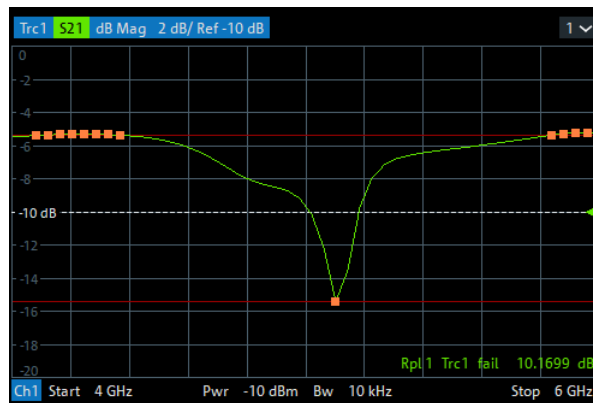

Note:

- Ripple check and display of limit lines are independent of each other:
 - The ripple limits can be displayed, no matter if the ripple check is enabled.
 - If "Ripple Check" is enabled, the ripple limits are checked, no matter if they are displayed.
 - The ripple check can even be enabled, if no limit lines are defined. In this case, the info field displays "No ripple defined!" and the limit check always passes.
- For each trace, ripple limits can only be set for a single cartesian trace format. If another trace format is selected, the ripple limit lines are hidden and the ripple check is suspended.

Remote command:

```
CALCulate<Chn>:RIPple:STATe  
CALCulate<Chn>:RIPple:FAIL?  
CALCulate:RIPple:FAIL:ALL?  
CALCulate<Chn>:RIPple:SEGment<Seg>:RESult?  
CALCulate<Chn>:RIPple:STATe:AREA
```

Ripple Fail Beep

Activates or deactivates the fail beep. The fail beep is a low-tone acoustic signal that is generated each time the analyzer detects an exceeded ripple limit. No fail beep can be generated if the ripple limit check is switched off.

These sounds are generated using the built-in sound chip and loudspeaker of the R&S ZND.

Remote command:

```
CALCulate<Chn>:RIPple:SOUND[:STATe]
```

Show Results All Traces

Defines the visibility of ripple info fields in the active recall set.

- If disabled, only the ripple info field of the active trace is displayed (in case it has ripple check enabled).
- If enabled, ripple info fields are displayed for all traces with ripple check enabled.

Remote command:

```
CALCulate:RIPple:DISPlay:RESult:ALL[:STATe]
```

Clear Test

Resets the limit check results.

Remote command:

```
CALCulate<Chn>:RIPple:CLEar
```

Global Check

See "[Global Check](#)" on page 307.

TTL1 Pass / TTL2 Pass

See "[TTL1 Pass / TTL2 Pass](#)" on page 307.

6.6.2.2 Define Ripple Test Dialog

The "Define Ripple Test" dialog defines the ripple limits for the active trace on a range-by-range basis. A separate ripple limit can be assigned to each range.

Access: TRACE – [LINE] > "Ripple Test" > "Def. Ripple Test..."



Defining ripple limits with minimum effort

Choose one of the following methods to create and handle ripple limit ranges efficiently:

- To configure a limit test with only a few ranges, use "Add" and edit each range in the table individually.
- Use the "Align All" button to create non-overlapping, contiguous ranges of equal width.
- Save your ripple ranges to a file so you can reuse or modify them in later sessions ("Save Ripple Test...", "Recall Ripple Test...").



Background information

Refer to [Chapter 5.4.1, "Limit Check"](#), on page 122.

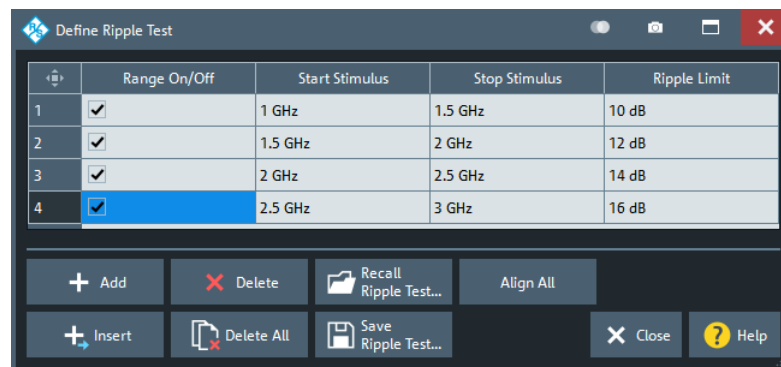

The "Define Ripple Test" dialog contains a table to edit the individual ranges of the ripple check ranges. The buttons below the table extend, shorten, or reorder the range list and save/recall ripple test data.

Range List

Defines the individual ripple limit ranges.

The table contains an automatically assigned current number for each range plus the following editable columns:

- "Range On/Off" enables or disables the ripple limit check in each range. Disabling the ripple limit check does not delete the range but hides the entry in the info field.
- "Start Stimulus" is the smallest stimulus (x-axis) value of the range.
- "Stop Stimulus" is the largest stimulus (x-axis) value of the range.
- "Ripple Limit" is the maximum allowed difference between the largest and the smallest trace value in the range.

The ripple limit range is displayed as two parallel, horizontal lines in the diagram. "Stop Stimulus" - "Start Stimulus" is the length of both lines (if the range is within the sweep range); "Ripple Limit" is their vertical distance. See [Chapter 5.4.1.2, "Rules for Ripple Test Definition"](#), on page 125.

Remote command:

```
CALCulate<Chn>:RIPPLE:SEGMENT<Seg>[:STATe]
```

```
CALCulate<Chn>:RIPPLE:SEGMENT<Seg>:STIMulus:START
```



```
CALCulate<Chn>:RIPple:SEGment<Seg>:STIMulus:STOP
CALCulate<Chn>:RIPple:SEGment<Seg>:LIMit
CALCulate<Chn>:RIPple:SEGment:COUNT?
```

Add / Insert / Delete / Delete All / Align All

The first four buttons below the range list extend, shorten, or reorder the list.

- "Add" adds a new range to the list. The new range is inserted after the previously selected range. The current range numbers are adapted; the start and stop stimulus values are set so that an overlap is avoided. Moreover, the ripple limit is estimated according to the measured ripple of the trace in the created range. The analyzer places no restriction on the number of ranges assigned to each trace.
- "Insert" adds a new range before the active range (marked by a blue background in the first column of the range list). The new range extends from the "Stop Stimulus" value of the range before the active range to the "Start Stimulus" value of the active range. Its ripple limit is estimated according to the measured ripple of the trace in the created range. The range numbers in the list are adapted.
If no range is active, "Insert" is equivalent to "Add".
- "Delete" removes the selected range from the list.
- "Delete All" clears the entire range list so it is possible to define or load a new ripple limit line.
- "Align All" redefines existing sweep ranges such that they cover the overall sweep range and have (almost) equal width. The ripple limits are estimated according to the measured ripple of the trace in the created ranges.

Remote command:

```
CALCulate<Chn>:RIPple:CONTRol:DOMain
CALCulate<Chn>:RIPple:DATA
CALCulate<Chn>:RIPple:DELeTe:ALL
```

Recall Ripple Test.../Save Ripple Test...

The buttons open an Open/Save File dialog to load a ripple limit line from a ripple limit file or store the current ripple limit configuration to a file.

Ripple limit files are ASCII files with the default extension `*.ripple` and a special file format. See [Chapter 5.4.1.5, "File Format for Ripple Limits"](#), on page 129.

Remote command:

```
MMEMory:LOAD:RIPple
MMEMory:STORE:RIPple
```

6.6.3 Circle Test Tab

Defines circular limit lines for complex trace formats ("Polar", "Smith", "Inv Smith"), visualizes them in the diagram and activates/deactivates the circle limit check.

Most of the control elements in the "Circle Test" tab are disabled if the active trace has a cartesian format.



Background information

Refer to [Chapter 5.4.1.3, "Circle Limits"](#), on page 126.

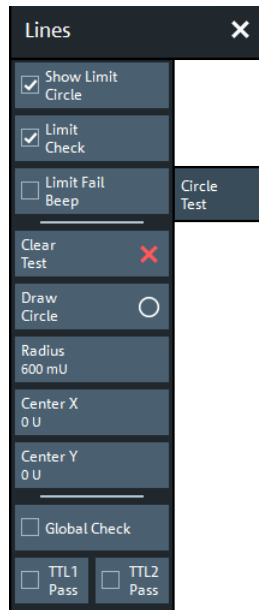

Show Limit Circle

Shows or hides the limit line associated with the active trace in a polar diagram area.

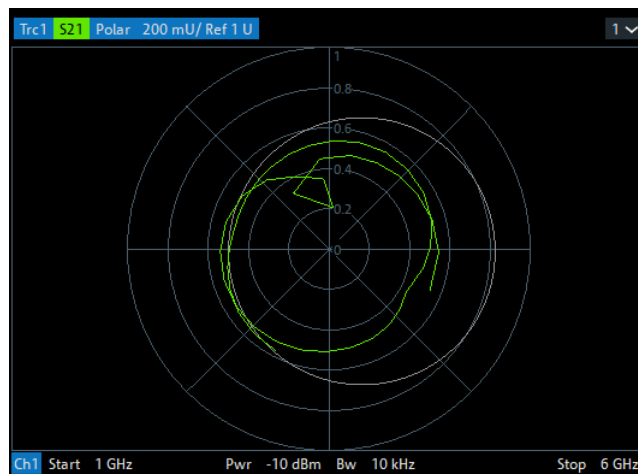

The limit line colors are defined in the "Define User Color Scheme" dialog (see [Chapter 6.16.3.2, "Define User Color Scheme Dialog"](#), on page 511). You can choose between various options:

- Assign the same color to traces and associated limit lines.
- Assign different colors to limit line segments with disabled limit check.

Note: Display of the limit line and limit check are independent of each other: Hiding the limit line does not switch off the limit check.

Remote command:

```
CALCulate<Chn>:LIMit:CIRCle:DISPlay[:STATe]
```

Limit Check

Switches the limit check of the active trace on or off.

When the limit check is switched on, a movable "PASS" or "FAIL" message is displayed in the diagram. If the limit check fails at a measurement point, the point is marked with a colored square. An acoustic signal ([Limit Fail Beep](#)) and a TTL signal indicating pass or fail can be generated in addition.

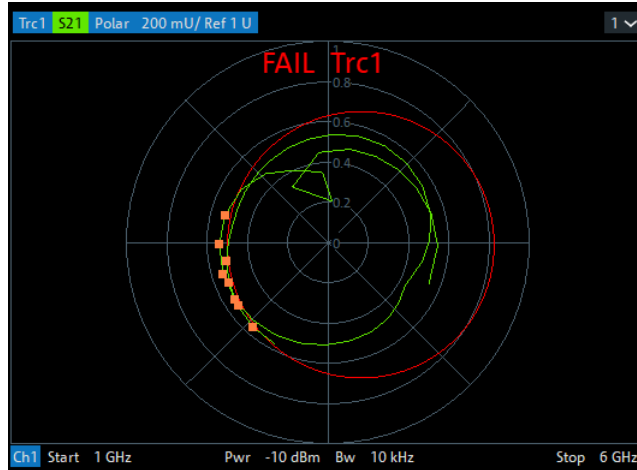

The appearance of the limit fail symbols is defined in the "Define User Color Scheme" dialog (see [Chapter 6.16.3.2, "Define User Color Scheme Dialog"](#), on page 511). You can choose between various options:

- Change the trace color between failed measurement points.
- Show or hide the colored squares.

Note:

- Circle limit check and display of limit circles are independent of each other:
 - The limit circles can be displayed, no matter if the circle limit check is enabled.
 - If "Limit Check" is enabled, the ripple limits are checked, no matter if they are displayed.
- If result evaluation is limited to a user-defined [display circle](#), the [Chapter 6.6.3, "Circle Test Tab"](#), on page 317 is only performed inside this display circle.
- The circle limits can only be checked if the trace format is complex. While a cartesian format is active, the limit circles are hidden and the circle limit check is suspended.
- If the limit check for (cartesian) [limit lines](#) is enabled, it is also evaluated in complex diagrams.

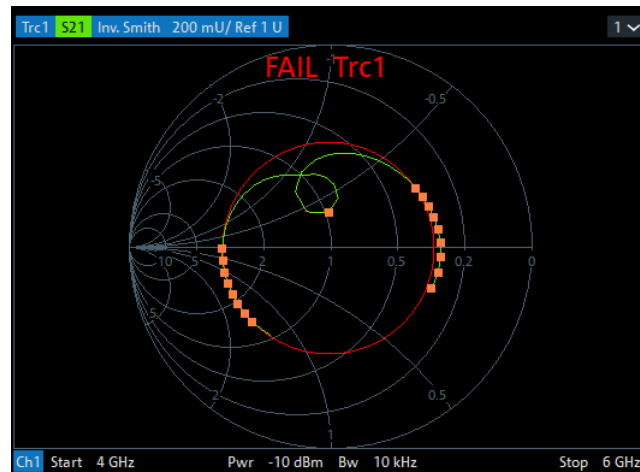

Figure 6-5: Simultaneous dB Mag limit line and circle check

Remote command:

```
CALCulate<Chn>:LIMit:CIRClE[:STATe]
CALCulate<Chn>:LIMit:CIRClE:FAIL?
CALCulate:LIMit:CIRClE:FAIL:ALL?
```

Limit Fail Beep

Activates or deactivates the fail beep. The fail beep is a low-tone acoustic signal that is generated each time the analyzer detects an exceeded limit. No fail beep can be generated if the limit check is switched off.

These sounds are generated using the built-in sound chip and loudspeaker of the R&S ZND.

Remote command:

```
CALCulate<Chn>:LIMit:CIRClE:SOUNd[:STATe]
```

Clear Test

Resets the limit check results.

Remote command:

```
CALCulate<Chn>:LIMit:CIRClE:CLEAr
```

Draw Circle

Activates touchscreen or mouse operation; tap the diagram at one border of the limit circle and draw the circle to the required size and position.

Remote command:

n/a

Radius / Center X / Center Y

Defines the limit circle by its radius and its center on the X-axis and Y-axis.

Remote command:

```
CALCulate<Chn>:LIMit:CIRClE:DATA
```

Global Check

See "Global Check" on page 307.

TTL1 Pass / TTL2 Pass

See "[TTL1 Pass / TTL2 Pass](#)" on page 307.

6.6.4 Display Circle Tab

The "Display Circle" functionality allows you to limit results in complex trace formats (Smith, Polar) to a user-defined circle. In particular, while the trace format is complex, line and circle limit checks are only performed inside the display circle.

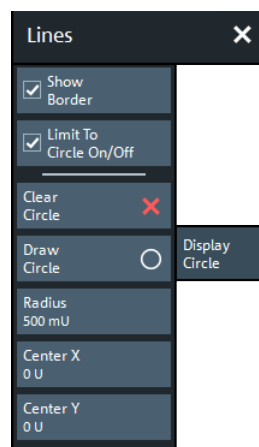

Most of the controls on this tab are only active, if the active trace is displayed in a complex format.

**Show Border**

If enabled, the border of the Display Circle is shown whenever the related trace is displayed in complex format.

The border color can be modified by a user-defined color scheme ([Element "Vertical Range Lines"](#)).

Remote command:

```
CALCulate<Chn>:LIMIT:DCIRCLE:DISPLAY[:STATE]
```

Limit to Circle On/Off

If enabled, only trace points within the configured "Display Circle" are shown, whenever the related trace is displayed in complex format. At the same time, the active limit tests (line, circle) are restricted to the configured "Display Circle".

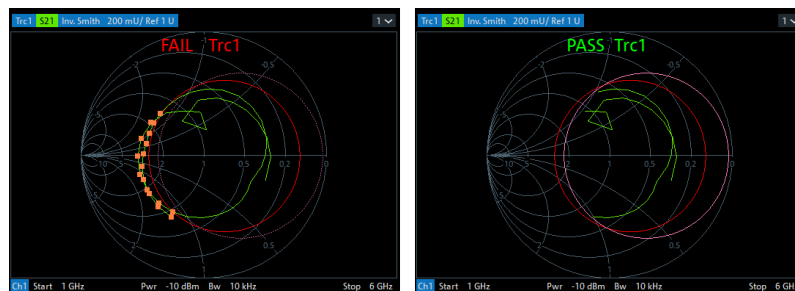

left ("FAIL") = "Circle Test" enabled, but not limited to "Display Circle"
 right ("PASS") = "Circle Test" enabled, but limited to "Display Circle"

Remote command:

`CALCulate<Chn>:LIMit:DCIRcle[:STATe]`

Clear Circle

Resets the "Display Circle" to its default configuration (unit circle; show border: off; limit to circle: off)

Remote command:

`CALCulate<Chn>:LIMit:DCIRcle:CLEar`

Draw Circle / Radius, Center X, Center Y

Defines the Display Circle – either by drawing it in the diagram area or by providing its radius and center.

Remote command:

`CALCulate<Chn>:LIMit:DCIRcle:DATA`

6.6.5 Horiz. Line Tab

Shows or hides a horizontal line associated to the active trace in a cartesian diagram area. The line can be moved to particular trace points to retrieve the response values. It also shows which parts of a trace are above or below a definite response value.



- The controls on this tab are only active if the active trace is displayed in cartesian format.
- If another trace format is selected, the line (position) is deleted.

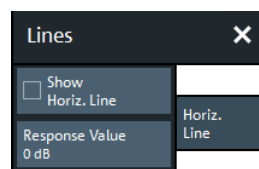

Show Horiz. Line

Displays or hides the horizontal line.

Remote command:

`CALCulate<Chn>:DLINe:STATe`

Response Value

Defines/shows the response value of the horizontal line.

Tip: Use the R&S ZND's drag and drop functionality to move the horizontal line to a particular position. The response value appears in the numeric entry field.

Remote command:

`CALCulate<Chn>:DLINe`

6.7 Marker Softtool

The "Marker" softtool allows you to position markers on a trace and to define their properties. Markers are also convenient tools for searching special points on traces and for scaling diagrams.

Access: TRACE – [MARKER]



Background information

Refer to the following sections:

- [Chapter 5.2.1.3, "Markers"](#), on page 84
- [Chapter 4.3.6.6, "Set by Marker"](#), on page 58

6.7.1 Markers Tab

Creates markers and configures their properties. Markers are available for all trace formats.

A first marker labeled "M1" is automatically created when the [MARKER] hardkey is pressed. The "Mkr 1" ... "Mkr 10" and "Ref Mkr" softkeys enable the corresponding markers.

"Add Marker" adds a new marker.



Related information

Refer to the following sections:

- [Chapter 5.2.1.3, "Markers"](#), on page 84
- [Chapter 4.3.4, "Handling Diagrams, Traces, and Markers"](#), on page 47

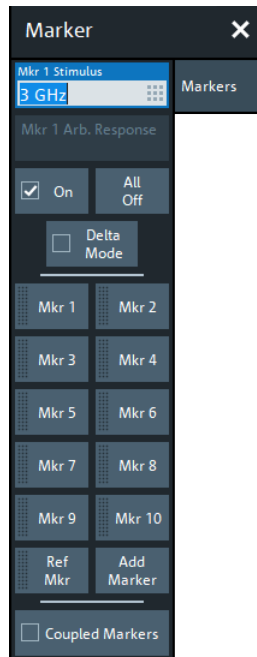

Mkr <i> Stimulus / Ref Mkr Stimulus

Gets/sets the stimulus value of the active marker.

Remote command:

```
CALCulate<Chn>:MARKer<Mk>:X
```

```
CALCulate<Chn>:MARKer<Mk>:REFeRence:X
```

Mkr <i> Arb. Response / Ref Mkr Arb. Response

Gets/sets the response value (Y position) of an "Arbitrary" marker (see "[Marker Mode](#)" on page 327).

Remote command:

```
CALCulate<Chn>:MARKer<Mk>:Y
```

```
CALCulate<Chn>:MARKer<Mk>:REFeRence:Y
```

On

Enables/disables the active marker.

Markers remember their "Marker Props" while disabled (see [Chapter 6.7.2, "Marker Props Tab"](#), on page 326). The marker properties are definitely lost when the associated trace is deleted.

Remote command:

```
CALCulate<Chn>:MARKer<Mk>[:STATe]
```

```
CALCulate<Chn>:MARKer<Mk>:REFeRence[:STATe]
```

All Off

Disables all markers of the active trace.

Markers remember their "Marker Props" while disabled (see [Chapter 6.7.2, "Marker Props Tab"](#), on page 326). The marker properties are definitely lost when the associated trace is deleted.

Tip: To disable a single marker, drag it into vertical direction to release it from the trace and drop it onto the "Delete" icon.

Remote command:

```
CALCulate<Chn>:MARKer<Mk>:AOFF
```

Delta Mode

Enables/disables the "Delta Mode" for the active marker. At the same time, enables the [Ref Mkr](#).

This function is inactive if the reference marker is the active marker.

Remote command:

```
CALCulate<Chn>:MARKer<Mk>:DELTA[:STATe]
```

Mkr 1 ... Mkr 10

Creates the markers numbered 1 to 10 and assigns them to the active trace. When a marker is created, a triangle labeled "M<i>" is positioned on the trace and the marker coordinates are displayed in the movable info field.

The stimulus position of an active marker can be entered in the "Mkr <i> Stimulus" entry field. The default position is the center of the sweep range. You can also drag and drop markers in a diagram to change their X position.

If the [Marker Mode](#) is "Arbitrary", also the response value (Y position) can be changed.

See also "[Activating and Moving Markers](#)" on page 85.

Remote command:

```
CALCulate<Chn>:MARKer<Mk>[:STATe]
```

```
CALCulate<Chn>:MARKer<Mk>:Y
```

```
CALCulate<Chn>:MARKer[:STATe]:AREA
```

Ref Mkr

Creates a reference marker and assigns it to the active trace. When a marker is created, a triangle labeled "R" is positioned on the trace and the marker coordinates are displayed in the info field.

The stimulus position of the active reference marker can be entered in the "Ref Marker Stimulus" entry field. The default position is the start of the sweep range or the position of the last active marker.

The reference marker defines the reference value for all markers that are in "Delta Mode".

Remote command:

```
CALCulate<Chn>:MARKer<Mk>:REFerence[:STATe]
```

```
CALCulate<Chn>:MARKer<Mk>:REFerence:Y
```

Add Marker

Adds a new marker to the active trace. Uses the next "free" marker number

Coupled Markers

Activates or deactivates [Marker Coupling](#). The label indicates the selected [Coupling Type](#):

"Coupling Type"	Label
"All"	"Coupled Markers"
"Channel"	"Coupled Markers in <name of active channel>"
"Diagram"	"Coupled Markers in <name of active diagram>"

Coupling also works if [Tracking](#) is enabled for *Marker <m>* in **one** trace. The *Marker <m>* of the other traces then follow the movements of the tracked marker. The same holds true for the reference marker.

Remote command:

`CALCulate:MARKer:COUPled[:STATE]`

6.7.2 Marker Props Tab

Modifies the properties of a marker created previously (see [Chapter 6.7.1, "Markers Tab"](#), on page 323). The functions (except "Export Markers...") are unavailable if the active trace contains no markers.

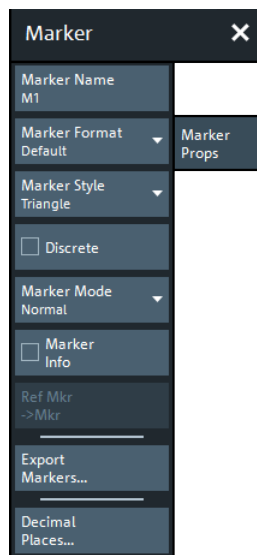

Marker Name

Assigns a (new) name to the active marker. Marker names can contain letters, numbers, blanks and special characters.

Remote command:

`CALCulate<Chn>:MARKer<Mk>:NAME`

`CALCulate<Chn>:MARKer<Mk>:REFErence:NAME`

Marker Format

Defines the formatting of the active marker in the movable marker info field.

For background information on marker formats, see ["Marker Format"](#) on page 86.

"Default" means that the marker is formatted according to the related trace's [Dflt Marker Frmt](#).

In "Arbitrary" [Marker Mode](#), if the transformation between trace format and marker format requires a concrete stimulus value, some result values in the marker info field can be unavailable. Those values are displayed as a sequence of dashes (-----).

Remote command:

```
CALCulate<Chn>:MARKer<Mk>:FORMat
```

```
CALCulate<Chn>:MARKer<Mk>:REFerence:FORMat
```

Marker Style

Defines how the selected marker is displayed on the screen.

Remote command:

n/a

Discrete

Discrete mode means that a marker can be set to discrete sweep points only. If discrete mode is switched off, the marker can be positioned on any point of the trace, and its response values are obtained by interpolation.

Remote command:

```
CALCulate<Chn>:MARKer<Mk>:MODE
```

```
CALCulate<Chn>:MARKer<Mk>:REFerence:MODE
```

Marker Mode

Determines if and how the marker's position is adjusted and if and how it can be moved in the diagram area.

Normal: If [Tracking](#) is enabled, the marker's stimulus value is updated automatically with every sweep, otherwise it is constant. The marker position is adjusted to the corresponding response value, i.e. the marker is always positioned on the trace.

If in the current trace format the X axis represents the stimulus, the marker can be moved horizontally. At the same time, the marker's stimulus and response values are adjusted, i.e. its vertical position automatically follows the trace.

Fixed: freezes the marker at the position determined by the current stimulus and response value. Tracking is disabled. The stimulus and response values are stored with the marker; they are not adjusted to subsequent sweeps or trace format changes.

If in the current trace format the X axis represents the stimulus, the marker can be moved horizontally. Moving the marker adjusts the markers's stimulus value, but its response value remains fixed.

Arbitrary: freezes the marker at the position determined by the current stimulus and response value. Tracking is disabled. The marker stores the stimulus value and – in addition – its X and Y coordinates in the current [Marker Format](#).

The marker can be moved freely inside the diagram, directly adjusting its X and Y coordinates. If in the current trace format the X axis represents the stimulus, the marker's stimulus value is adjusted accordingly. Otherwise the marker's stimulus value remains unchanged and is not shown in the [Marker Info Field](#). Switching between trace formats resets the marker position to the response value at the marker's stimulus value, i.e. the marker snaps to the trace.

Remote command:

`CALCulate<Chn>:MARKer<Mk>:TYPE`

`CALCulate<Chn>:MARKer<Mk>:REFerence:TYPE`

Marker Info

Displays the marker coordinates above the marker symbol.

Remote command:

n/a

Ref Mkr -> Mkr

Places the reference marker to the position of the active marker. "Ref. Mkr -> Mkr" is not active if the active marker is a reference marker.

Remote command:

n/a

Export Markers

Calls up a "Save As"... dialog to store the current marker values to a marker file.

The analyzer uses a simple ASCII format to export marker values. By default, the marker file extension is *.txt. The file contains all traces in the active recall set together with their names and measured quantities. Below each trace, the file shows a list of all markers with their names, stimulus and response values.

The following example of a marker file describes a recall set with two traces, "Trc1" and its memory trace "Mem2[Trc1]". "Trc1" has a reference marker "R" and three normal markers "M1, M2, M3" assigned, the memory trace has no markers.

```
Trc1 s21
R 869.01766 MHz -4.751 dB
M1 5.621400 GHz 1.351 dB
M2 3.380996 GHz -6.043 dB
M3 1.928122 GHz -4.700 dB

Mem2[Trc1] s21
No Markers
```

Remote command:

`MMEMoRY:STORe:MARKer`

Decimal Places...

Opens the "User Interface" tab of the "System Config" dialog, which allows to define the (maximum) number of decimal digits for different units. See ["User Interface Tab"](#) on page 522.

6.7.3 Marker Search Tab

Provides "Marker Search" functions that move the active marker to a (local) maximum or minimum of the active trace.

The search operation can be restricted to a configurable range of stimulus values ("Search Range..."). By default, the search range is equal to the entire sweep range.

If necessary, the active marker is enabled to indicate the search result.



Background information

Refer to "[Basic Marker Search Functions](#)" on page 89.

6.7.3.1 Controls on the Marker Search Tab

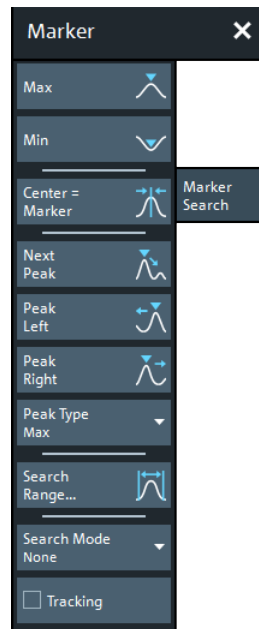

Max / Min

Sets the active marker to the absolute maximum or minimum in the search range, i.e. to the largest or smallest of all response values. If a complex trace format (e.g. a polar diagram) is active, the marker is set to the measurement point with the maximum or minimum magnitude.

"Max" and "Min" also overwrite the current "Search Mode" (--> "Search Min" and "Search Max") and the "Peak Type" for the peak search functions.

Remote command:

```
CALCulate<Chn>:MARKer<Mk>:FUNction:EXECute MINimum | MAXimum
CALCulate<Chn>:MARKer<Mk>:FUNction:RESult?
```

Center = Marker

See "[Center = Marker / Start = Marker / Stop = Marker / Span = Marker](#)" on page 342.

Next Peak

Sets the active marker to the next local maximum or minimum in the search range, depending on the selected [Peak Type](#).

Remote command:

```
CALCulate<Chn>:MARKer<Mk>:FUNction:EXECute NPEak
CALCulate<Chn>:MARKer<Mk>:FUNction:RESult?
```

Peak Left / Peak Right

Sets the active marker to the next local maximum or minimum to the left or right of the current marker position, depending on the selected [Peak Type](#).

Remote command:

```
CALCulate<Chn>:MARKer<Mk>:FUNction:EXECute LPEak | RPEak  
CALCulate<Chn>:MARKer<Mk>:FUNction:RESult?
```

Peak Type

Defines the peak type to be searched for using [Next Peak](#) and "Next Peak", [Peak Left / Peak Right](#):

- If "Max" is active, then the marker is set to the next maximum. The next maximum is the maximum with the largest response value that is below the current marker response value.
- If "Min" is active, then the marker is set to the next minimum. The next minimum is the minimum with the smallest response value that is above the current marker response value.
- If "Min or Max" is active, then the marker is set to the next minimum or maximum, whichever has the smallest distance from the current marker response value.

Remote command:

```
CALCulate<Chn>:MARKer<Mk>:FUNction:EXECute LPEak | RPEak
```

Search Range...

Opens the [Search Range Dialog](#).

Tracking

Enables/disables tracking of the active marker for the current [Search Mode](#), which causes the marker to be updated after each sweep (or after each sweep point in case of "Sweep Progress").

Among the available search modes, the tracking functionality only makes sense for:

- "Min" and "Max", where such an update typically causes the marker to change both its horizontal and vertical position and
- "Target Search", where typically only the horizontal position changes
- "Sweep Progress" for long duration sweeps

Define an adequate "Search Range" to restrict the search to the adequate frequency or power interval (see [Chapter 6.7.3.2, "Search Range Dialog"](#), on page 331).

Note: Tracking for bandfilter search can be activated separately, see ["Tracking"](#) on page 341.

Remote command:

```
CALCulate<Chn>:MARKer<Mk>:SEARch:TRACking
```

Marker Config...

Opens the [Marker Config Dialog](#).

6.7.3.2 Search Range Dialog

The "Search Range" dialog confines the "Marker Search" and "Target Search" for the selected marker to a subrange of the sweep. The search range is a continuous interval of the sweep variable.

Access:

- TRACE – [MARKER] > "Marker Search" > "Search Range..."
- TRACE – [MARKER] > "Target Search" > "Search Range..."

If [Tracking](#) is active, the assigned "Search Range" applies to all sweeps and can be used to achieve uniqueness in "Min", "Max" or "Target Search".

See also [Chapter 6.5.8, "Trace Statistics Tab"](#), on page 286.

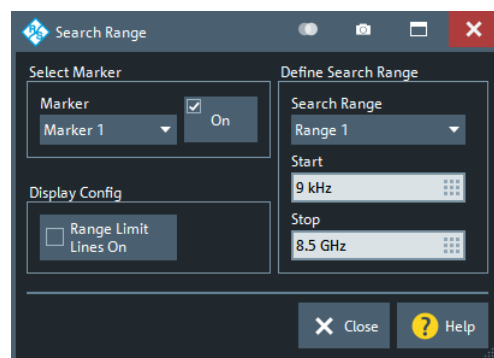

It is possible to define search ranges for each recall set and assign them to the corresponding markers and the reference marker.

Select Marker

Selects the reference marker or one of the numbered markers that can be assigned to the trace. If a numbered marker does not exist, it is created when "On" is checked. A created marker is displayed in the center of the search range.

Search Range

Selects the "Search Range" to be assigned to the selected marker. "Full Span" means that the "Search Range" is equal to the sweep range. Besides, it is possible to store up to 10 customized search ranges.

The "Search Range"s are bordered by the "Start" and "Stop" values. "Start" must be smaller than "Stop", otherwise the second value is automatically adjusted.

"Search Range" properties

The 10 search ranges are valid for the entire recall set. Each of them can be assigned to any marker in the recall set, irrespective of the trace and channel that the marker belongs to.

The default search range of any new marker is "Full Span". The analyzer provides the greatest flexibility in defining search ranges. In particular, two search ranges can overlap or even be identical. The search is confined to the part of the search range that belongs to the sweep range.

The following example shows how "Search Range"s can be used to search a trace for several local maxima.

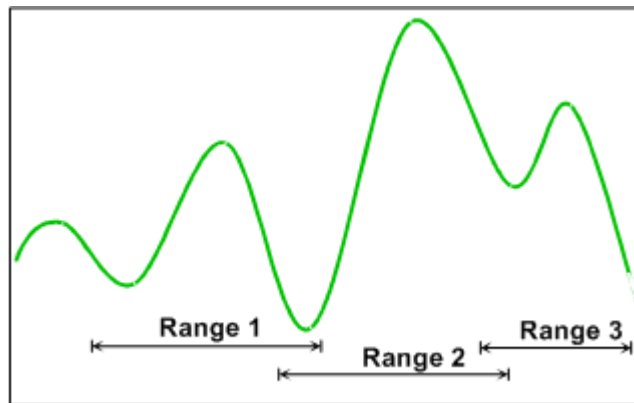

Note: The marker Search Ranges are identical to the evaluation ranges for trace statistics. For more information, see [Chapter 6.5.8.2, "Evaluation Range Dialog"](#), on page 291.

Remote command:

```
CALCulate<Chn>:MARKer<Mk>:FUNction:DOMain:USER[:RANGE]
CALCulate<Chn>:MARKer<Mk>:FUNction:DOMain:USER:START
CALCulate<Chn>:MARKer<Mk>:FUNction:DOMain:USER:STOP
```

Range Limit Lines On

Displays or hides the range limit lines in the diagram area. Range limit lines are two vertical lines at the Start and Stop values of the active search range ("Range 1" to "Range 10").

The line color can be modified by a user-defined color scheme ([Element "Vertical Range Lines"](#)).

Remote command:

```
CALCulate<Chn>:MARKer<Mk>:FUNction:DOMain:USER:SHOW
```

6.7.3.3 Marker Config Dialog

The "Marker Config" dialog allows you to configure the peak searches for the active trace and all its markers.

Access:

- TRACE – [MARKER] > "Marker Search" > "Marker Config..."
- TRACE – [MARKER] > "Multiple Peak" > "Marker Config..."

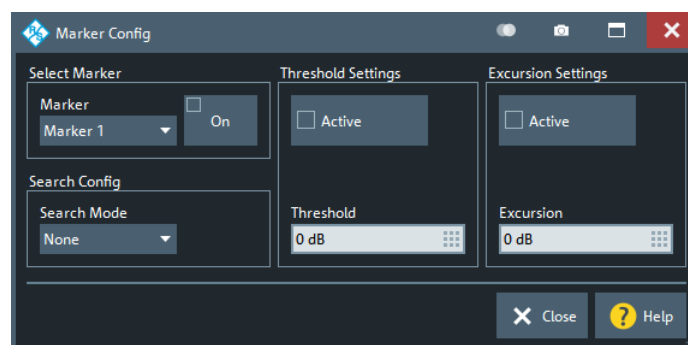

Select Marker

Allows you to select the related marker and to activate or deactivate it.

Remote command:

```
CALCulate<Chn>:MARKer<Mk>[:STATe]
```

Search Config

Allows you to select the [Target Search Mode](#) of the selected marker.

Remote command:

```
CALCulate<Chn>:MARKer<Mk>:FUNction:EXECute
```

Threshold Settings

Defines a threshold for (single) peak searches and activates it.

If "Active", only maxima above and minima below the configured "Threshold" are considered.

The unit is derived from the active trace format and cannot be modified. Changing the trace format resets the "Threshold" to a format-specific default value.

Remote command:

```
CALCulate<Chn>:MARKer<Mk>:THReshold  
CALCulate<Chn>:MARKer<Mk>:THReshold:STATe
```

Excursion Settings

Defines a minimum excursion for peak searches and activates it.

If "Active", only peaks with an excursion above the configured "Excursion" value are considered. By definition, the excursion of a peak is the smaller of the absolute differences in measured values from the adjoining peaks of opposite polarity.

The unit is derived from the active trace format and cannot be modified. Changing the trace format resets the "Excursion" to a format-specific default value.

Remote command:

```
CALCulate<Chn>:MARKer<Mk>:EXCursion  
CALCulate<Chn>:MARKer<Mk>:EXCursion:STATe
```

6.7.4 Multiple Peak Tab

"Multiple Peak" search allows you to find multiple local minima/maxima at once.



Background information

Refer to "[Basic Marker Search Functions](#)" on page 89.

6.7.4.1 Controls on the Multiple Peak Tab

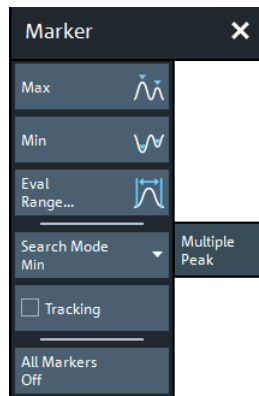

Max / Min

Sets up to 10 markers to the highest maxima or lowest minima in the configured [Eval Range](#). If a complex trace format is active (e.g. a polar diagram), the markers are set to the measurement points with the maximum or minimum magnitude.

The required markers are created/deleted as needed.

Remote command:

```
CALCulate<Chn>:MARKer<Mk>:FUNction:EXECute MMAXimum | MMINimum
CALCulate<Chn>:MARKer<Mk>:FUNction:RESult?
```

Eval Range

Opens the [Evaluation Range Dialog](#) that allows you to set the domain for the multiple peak search. A modified domain takes effect the next time [Max / Min](#) is used.

Tracking

Enables or disables tracking for "Multiple Peak" search. If enabled, a new multiple peak search is performed for each sweep (creating/deleting markers as needed).

Define an [Eval Range](#) to restrict the search to the adequate frequency or power interval.

Remote command:

```
CALCulate<Chn>:MARKer<Mk>:SEARch:TRACking
```

Marker Config...

Opens the [Multiple Marker Config Dialog](#).

All Markers Off

See ["All Off"](#) on page 324.

6.7.4.2 Multiple Marker Config Dialog

The "Multiple Marker Config" dialog allows you to configure the multiple peak searches for the active trace.

Access: TRACE – [MARKER] > "Multiple Peak" > "Marker Config..."

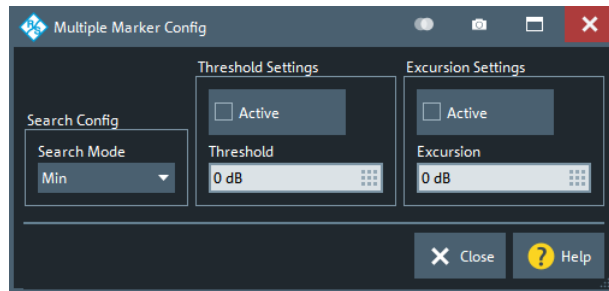

Search Config

Same as selecting [Max / Min](#).

Remote command:

```
CALCulate<Chn>:MARKer<Mk>:FUNction:EXECute MMAXimum | MMINimum
```

Threshold Settings

Defines a threshold for multiple peak searches and activates it.

If "Active", only maxima above and minima below the configured "Threshold" are considered.

The unit is derived from the active trace format and cannot be modified. Changing the trace format resets the "Threshold" to a format-specific default value.

Remote command:

```
CALCulate<Chn>:MARKer:MPEak:THReshold
CALCulate<Chn>:MARKer:MPEak:THReshold:STATe
```

Excursion Settings

Defines a minimum excursion for multiple peak searches and activates it.

If "Active", only peaks with an excursion above the configured "Excursion" value are considered. By definition, the excursion of a peak is the smaller of the absolute differences in measured values from the adjoining peaks of opposite polarity.

The unit is derived from the active trace format and cannot be modified. Changing the trace format resets the "Excursion" to a format-specific default value.

Remote command:

```
CALCulate<Chn>:MARKer:MPEak:EXCursion
CALCulate<Chn>:MARKer:MPEak:EXCursion:STATe
```

6.7.5 Target Search Tab

The "Target Search" functions use markers to locate trace points with a specific response value ("Target Value"). The functions are unavailable if the active trace contains no markers (e.g. after "All Markers Off").

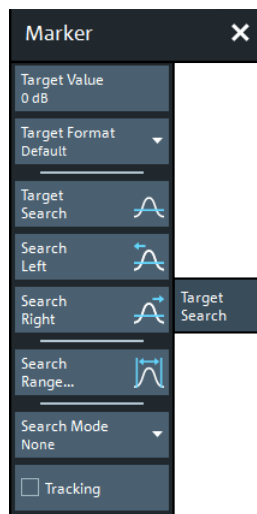

Some of the "Target Search" functions are equal to other marker search functions. Refer to the following sections:

- [Chapter 6.7.3.2, "Search Range Dialog"](#), on page 331
- ["Tracking"](#) on page 330

Target Value

Specifies the target value for the search.

The VNA software allows you to specify the target value in different formats (see [Target Format](#) below). For example, you can search for a particular phase value in a Smith chart.

Remote command:

`CALCulate<Chn>:MARKer<Mk>:TARGet`

Target Format

Selects the format that is used to specify the [Target Value](#).

The selected target format applies to the current marker only: each marker can have a different target format. The table below gives an overview on how a complex target value $z = x + jy$ is converted.

Target Format	Description	Formula
"Lin Mag"	Magnitude of z , unconverted.	$ z = \sqrt{x^2 + y^2}$
"dB Mag"	Magnitude of z [dB]	$\text{Mag}(z) = 20 \log z \text{ dB}$
"Phase"	Phase of z [°]	$\varphi(z) = \arctan(y/x)$
"Phase unwrap"	Unwrapped phase of z comprising the complete number of 360° phase rotations [°]	$\Phi(z) = \varphi(z) + 2k \cdot 360^\circ$
"Real"	Real part of z	$\text{Re}(z) = x$
"Imag"	Imaginary part of z	$\text{Im}(z) = y$

Target Format	Description	Formula
"SWR"	(Voltage) Standing Wave Ratio	$SWR = (1 + z) / (1 - z)$
"Default"	Identical to trace format. Note: the Smith and Polar traces use "Lin Mag" as the default format for target value.	-

Remote command:

```
CALCulate<Chn>:MARKer<Mk>:SEARch:FORMat
```

Target Search

Activates the search and sets the active marker to the defined target value. If the target value occurs at several stimulus values, the marker is placed to the search result with the smallest stimulus value. The other measurement points with the same target value can be located using the "Search Right" function.

If the target is not found (e.g. because the active trace does not contain the target value), then the active marker is not moved away from its original position.

Remote command:

```
CALCulate<Chn>:MARKer<Mk>:FUNction:EXECute TARGet  
CALCulate<Chn>:MARKer<Mk>:FUNction:RESult?
```

Search Left/Search Right

Searches the [Target Value](#) to the left/right of the active marker's stimulus value within the current search range (see [Chapter 6.7.3.2, "Search Range Dialog"](#), on page 331).

If the search is successful, the active marker is moved to the next smaller/larger stimulus value with this target value. Use "Search Left"/"Search Right" repeatedly to locate the other ones.

Remote command:

```
CALCulate<Chn>:MARKer<Mk>:FUNction:EXECute LTARGet  
CALCulate<Chn>:MARKer<Mk>:FUNction:RESult?
```

Search Mode

Displays and sets the current marker search mode.

Select one of the predefined max, min, peak, or target searches or select "Sweep Progress" to track the position of the sweep cursor.

Remote command:

```
CALCulate<Chn>:MARKer<Mk>:FUNction:EXECute
```

6.7.6 Bandfilter Tab

"Bandfilter" search allows you to search for trace segments with a bandpass or band-stop shape, and determine characteristic filter parameters.



Background information

Refer to ["Bandfilter Search"](#) on page 89.

Bandfilter for arbitrary scalar traces

"Bandfilter" search can be used for a broad range of measured quantities (see [Chapter 6.2, "Meas Softtool"](#), on page 221). To obtain real filter parameters, the trace format must be "dB Mag", the measured quantity must be a transmission S-parameter and a frequency sweep must be performed. However, for other formats, measured quantities or sweep types, the "Bandfilter" functions can still be useful to analyze general trace properties.

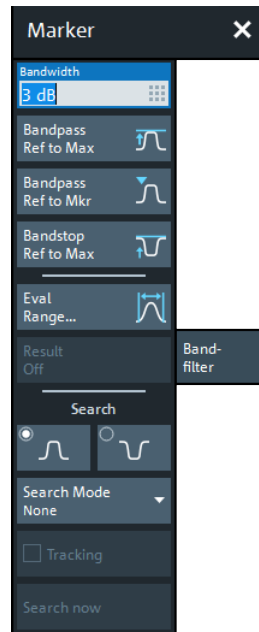

The "Eval Range..." button opens the "Evaluation Range" dialog that allows you to narrow the "Bandfilter" search to a particular stimulus range. See [Evaluation Range Dialog](#).

Bandwidth

Specifies the minimum excursion of the bandpass and bandstop peaks.

- A bandpass peak must fall off on both sides by the specified <Bandwidth> value to be considered a valid peak.
- A bandstop peak must be <Bandwidth> below the maximum level in the search range (bandpass value) to be considered a valid peak.

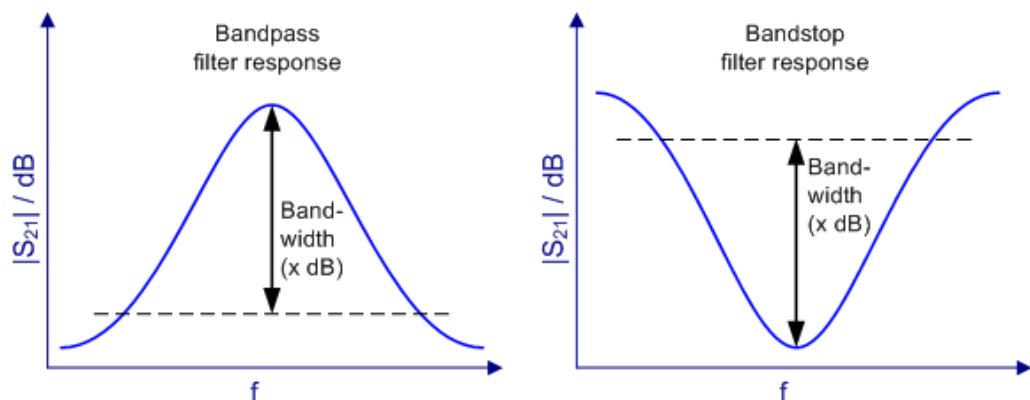

Remote command:

```
CALCulate<Chn>:MARKer<Mk>:BWIDth
```

Bandpass Ref to Max

Activates the search for a bandpass region on the active trace and activates [Tracking](#). The located bandpass region is the tallest peak in the search range with a minimum excursion as specified by the "Bandwidth" parameter.

If "Bandpass Ref to Max" is selected, the analyzer uses (or creates) the four markers "M1" to "M4" to locate the **bandpass region**.

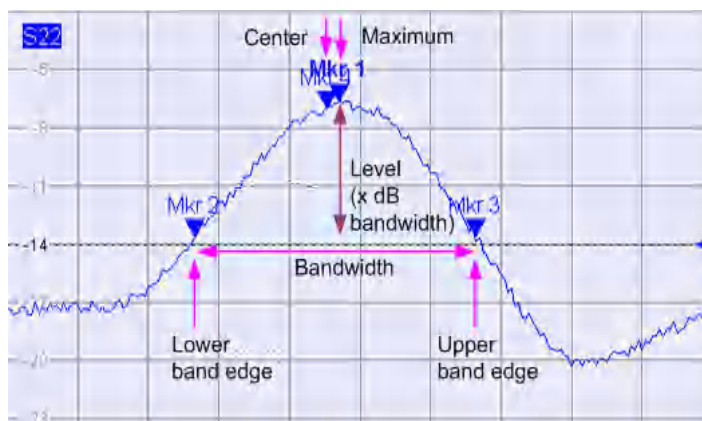

- "M1" indicates the maximum of the peak ("Max").
- "M2" indicates the point on the left edge of the peak where the trace value is equal to the maximum minus the bandwidth factor ("Lower Edge").
- "M3" indicates the point on the right edge of the peak where the trace value is equal to the maximum minus the bandwidth factor ("Upper Edge").
- "M4" indicates the center of the peak. Depending on a system setting, the center is either calculated as the geometric or the arithmetic mean of the "Lower Edge" and "Upper Edge" frequencies (see ["Geometric Calculation of Bandfilter Center"](#) on page 527).

The search results are displayed in the movable "Bandfilter" info field.

Remote command:

```
CALCulate<Chn>:MARKer<Mk>:FUNction:BWIDth:MODE BPASS
```

```
CALCulate<Chn>:MARKer<Mk>:FUNction:EXECute BFILter
```

```
CALCulate<Chn>:MARKer:SEARch:BFILter:RESult[:STATe]:AREA
```

Bandpass Ref to Mkr

Activates the search for a bandpass region on the active trace and activates [Tracking](#), starting at the position of the active marker. A bandpass region is the closest peak in the evaluation range that has a minimum excursion as specified by the "Bandwidth" parameter.

In contrast to a "Bandpass Ref to Max", the "Bandpass Ref to Mkr" does not change the position of the active markers. The search results are displayed in the movable "Bandfilter" info field.

Remote command:

```
CALCulate<Chn>:MARKer<Mk>:FUNction:BWIDth:MODE BPRMarker
CALCulate<Chn>:MARKer<Mk>:FUNction:EXECute BFILter
```

Bandstop Ref to Max

Activates the search for a bandstop region on the active trace and activates [Tracking](#). A bandstop region is the lowest peak (local minimum) in the search range, whose level is at least <Bandwidth> below the maximum (passband value).

If "Bandstop Ref to Max" is selected, the analyzer uses (or creates) the four markers "M1" to "M4" to locate the **bandstop region**.

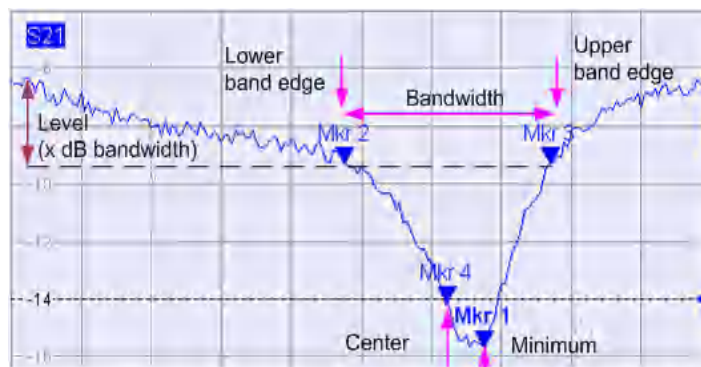

- "M1" indicates the minimum of the peak ("Min").
- "M2" indicates the "Lower Edge" of the bandstop, i.e. the point on the left edge of the peak where the trace value is equal to the maximum in the search range (passband value) minus the specified [Bandwidth](#).
- "M3" indicates the "Upper Edge" of the bandstop, i.e. the point on the right edge of the peak where the trace value is equal to the maximum in the search range (passband value) minus the specified "Bandwidth".
- "M4" indicates the center of the peak. Depending on a system setting, the center is either calculated as the geometric or the arithmetic mean of the "Lower Edge" and "Upper Edge" positions (see ["Geometric Calculation of Bandfilter Center"](#) on page 527).

The search results are displayed in the movable "Bandfilter" info field.

Remote command:

```
CALCulate<Chn>:MARKer<Mk>:FUNction:BWIDth:MODE BStOp
CALCulate<Chn>:MARKer<Mk>:FUNction:EXECute BFILter
```

Result Off

Hides the movable info field with the results of a bandpass or a bandstop search and disables [Tracking](#). The info field is displayed again (and tracking re-enabled) when a new "Bandfilter" search is performed.

Remote command:

```
CALCulate<Chn>:MARKer:SEARch:BFILter:RESult[:STATe]
```

Search (Bandpass or Bandstop) / Search Mode

Enables a bandpass or bandstop search (left/right icon) for an arbitrary search mode. The search modes have the following effect:

- "Ref to Max": The bandpass (bandstop) is the tallest (lowest peak) in the search range. For a detailed description, refer to ["Bandpass Ref to Max"](#) on page 339 and ["Bandstop Ref to Max"](#) on page 340.
- "Ref to Marker": The bandpass (bandstop) is the tallest (lowest) peak in the search range. The response value for the lower and upper band edges is calculated as the response value at the active marker position plus (minus) the [Bandwidth](#). To be valid, the peak must be above (below) the response value for the band edges.
- "Absolute Level:" The bandpass (bandstop) is the tallest (lowest) peak in the search range. To be valid, the peak must be above (below) $-$ "Bandwidth". The Lower Band Edge and Upper Band Edge values are given by the frequencies where the trace is equal to $-$ "Bandwidth".
- "None": "Bandfilter" search switched off, result off.

Remote command:

```
CALCulate<Chn>:MARKer<Mk>:FUNction:BWIDth:MODE
```

Tracking

Causes the active "Bandfilter" search to be repeated after each sweep: When tracking mode is active, the markers typically change their horizontal and vertical positions as the measurement proceeds.

Tracking mode properties

Tracking modes are available for all search modes. The tracking modes for minimum/maximum/peak search and target search are coupled; tracking for "Bandfilter" search can be activated separately. Tracking is activated automatically when one of the "Bandfilter" search modes is selected.

Remote command:

"Bandfilter" tracking and marker/target search tracking are controlled with the same command:

```
CALCulate<Chn>:MARKer<Mk>:SEARch:TRACking
```

6.7.7 Set by Marker Tab

The "Set by Marker" functions use the active marker to define the sweep range, scale the diagram and introduce an electrical length offset. The functions are unavailable if the active trace contains no markers (e.g. after "All Markers Off").

**Examples**

Refer to [Chapter 4.3.6.6, "Set by Marker"](#), on page 58.

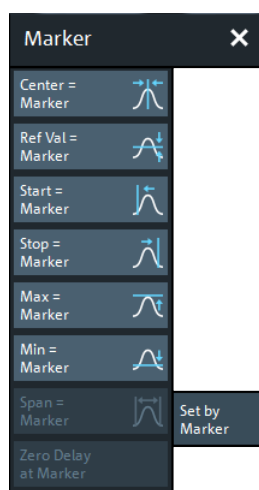

Center = Marker / Start = Marker / Stop = Marker / Span = Marker

The following functions use the stimulus value of the active marker to define the sweep range.

- "Center = Marker" sets the center of the sweep range equal to the stimulus value of the active marker, leaving the span unchanged. The active marker appears in the center of the diagram.
- "Start = Marker" sets the beginning (start) of the sweep range equal to the stimulus value of the active marker, leaving the end (stop) value unchanged. The active marker appears at the left edge of the diagram.
- "Stop = Marker" sets the end (stop) of the sweep range equal to the stimulus value of the active marker, leaving the beginning (start) unchanged. The active marker appears at the right edge of the diagram.
- "Span = Marker" is only available for frequency sweeps (linear or logarithmic). It is enabled if the active marker is in [Delta Mode](#). "Span = Marker" adjusts the sweep span to the range between the active delta marker and the reference marker.

Remote command:

```
CALCulate<Chn>:MARKer<Mk>:FUNction:CENTer
```

```
CALCulate<Chn>:MARKer<Mk>:FUNction:START
```

```
CALCulate<Chn>:MARKer<Mk>:FUNction:STOP
```

```
CALCulate<Chn>:MARKer<Mk>:FUNction:SPAN
```

Ref Val = Marker / Max = Marker / Min = Marker

The following functions use the response value of the active marker to scale the y-axis of the diagram:

- "Ref Val = Marker" sets the reference value equal to the response value of the active marker, leaving the values of the vertical divisions ("Scale / Div") unchanged.
- "Max = Marker" sets the upper edge of the diagram equal to the response value of the active marker, leaving the values of the vertical divisions ("Scale / Div") unchanged.
- "Min = Marker" sets the lower edge of the diagram equal to the response value of the active marker, leaving the values of the vertical divisions ("Scale / Div") unchanged.

Remote command:
n/a

Zero Delay at Marker

This function is available for [Delay](#) traces only. It shifts the trace in vertical direction so that the delay at the marker position becomes zero. Mathematically, it modifies the measurement results by subtracting the delay at the current marker position.

The delay represents the propagation time of the wave. Hence "Zero Delay at Marker" performs an electrical length compensation, by adding or subtracting a simulated loss-less transmission line of variable length to or from the test port. This shift of the reference plane must be carried out on the "Delay" trace, but has an impact on all trace formats.

A standard application of "Zero Delay at Marker" is correction of the constant delay caused by the interconnecting cables between the analyzer test ports and the DUT (line stretch).

Note: "Zero Delay at Marker" modifies the "Offset" parameters and therefore influences the entire channel.

Remote command:
n/a

6.7.8 Info Field Tab

Displays or hides the marker info field and selects its contents. The functions are self-explanatory.



Background information

Refer to "[Marker Info Field](#)" on page 85

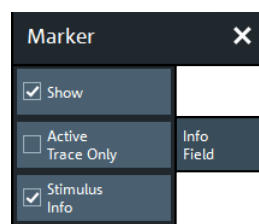

6.7.9 Marker Coupling Tab

Allows you to set up and control marker coupling.



Background information

Refer to "[Marker Coupling](#)" on page 88.

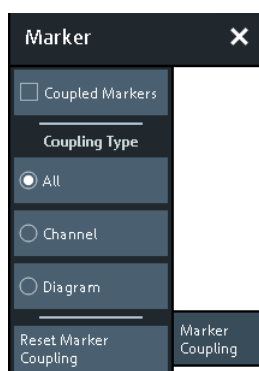

Coupled Markers

Activates or deactivates [Marker Coupling](#). The label indicates the selected [Coupling Type](#):

"Coupling Type"	Label
"All"	"Coupled Markers"
"Channel"	"Coupled Markers in <name of active channel>"
"Diagram"	"Coupled Markers in <name of active diagram>"

Coupling also works if [Tracking](#) is enabled for *Marker <m>* in **one** trace. The *Marker <m>* of the other traces then follow the movements of the tracked marker. The same holds true for the reference marker.

Remote command:

```
CALCulate:MARKer:COUPled[:STATE]
```

Coupling Type

Determines the set of traces whose markers are coupled to the markers of the active trace when [marker coupling](#) is enabled.

- **"All"**: marker coupling applies to all traces in the active recall set that have the same stimulus variable as the active trace
- **"Channel"**: marker coupling applies to all traces in the active channel
- **"Diagram"**: marker coupling applies to all traces in the active diagram that have the same stimulus variable as the active trace

The selected "Coupling Type" applies to all marker coupling relations in the current recall set. Changing the "Coupling Type" automatically disables marker coupling throughout the recall set.

Remote command:

```
CALCulate:MARKer:COUPled:TYPE
```

Reset Marker Coupling

Convenience function for disabling [marker coupling](#) and setting the [Coupling Type](#) to "All" (default).

Remote command:

```
CALCulate:MARKer:COUPled[:STATE] OFF
```

```
CALCulate:MARKer:COUPled:TYPE ALL
```

6.8 Stimulus Softtool

On the "Stimulus" softtool, you can access to the stimulus parameters of the active channel. If the active trace is represented in [Time Domain](#), it also allows you to configure the "observation interval".

Access: STIMULUS – [START] | [STOP] | [CENTER] | [SPAN] hardkey



- While in Cartesian diagrams the x-axis represents the stimulus values, in polar and Smith diagrams this direct relation is lost. In any case, a marker can be used to display the stimulus value of a given trace point.
For "Time Domain" traces, points in the "observation interval" are interpreted as stimulus values.
- All stimulus settings except the "Time Domain X-Axis" settings are channel settings. "Time Domain X-Axis" applies to the active (time domain) trace only.



Background information

Refer to the following sections:

- [Chapter 5.1.3, "Traces, Channels and Diagrams"](#), on page 70
- [Chapter 4.3.6.2, "Setting the Sweep Range"](#), on page 56
- [Chapter 4.3.6.6, "Set by Marker"](#), on page 58

6.8.1 Stimulus Tab

Defines the sweep range in the current channel, depending on the sweep type.



Related Settings

Refer to the following sections:

- [Chapter 5.1.4.4, "Stimulus and Sweep Types"](#), on page 76
- [Chapter 6.10.2, "Sweep Type Tab"](#), on page 355

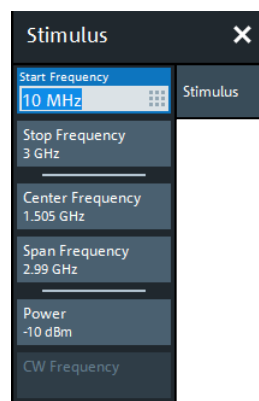

The following "Stimulus" settings are also available on the "Power" tab:

- [Power](#)
- [Start Power / Stop Power](#)

Start Frequency / Stop Frequency / Center Frequency / Span Frequency

Defines the sweep range for non-segmented frequency sweeps.

For a [Lin Freq](#) sweep, setting "Start Frequency" and "Stop Frequency" or "Center Frequency" and "Span Frequency" are alternatives.

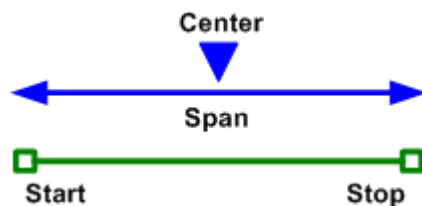

For a [Log Freq](#) only "Start Frequency" and "Stop Frequency" can be set.

Note: For segmented frequency sweeps the start and stop frequencies and the number of sweep points are defined per segment. See [Chapter 6.10.2.2, "Define Segments Dialog"](#), on page 360.

Remote command:

```
[SENSe<Ch>:] FREQuency: START
[SENSe<Ch>:] FREQuency: STOP
[SENSe<Ch>:] FREQuency: CENTER
[SENSe<Ch>:] FREQuency: SPAN
SYSTem: FREQuency? (query frequency range of the network analyzer)
```

Number of Points

Sets the total number of measurement points for [CW Mode](#) sweeps.

This value can also be set on the "Sweep Params" tab of the "Sweep" softtool (see ["Number of Points"](#) on page 353).

Remote command:

```
[SENSe<Ch>:] SWEep: POINTs
```

CW Frequency

Sets the fixed frequency for [Power](#), [CW Mode](#), and [Time](#) sweeps.

Remote command:

```
[SENSe<Ch>:] FREQuency: FIXEd
[SENSe<Ch>:] FREQuency [:CW]
SOURce<Ch>: FREQuency<PhyPt>: FIXEd
SOURce<Ch>: FREQuency<PhyPt> [:CW]
```

6.8.2 Power Tab

The "Power" tab provides settings related to transmit and receive power. It is also displayed on the "Power Bw Avg" softtool.

6.8.2.1 Controls on the Power Tab

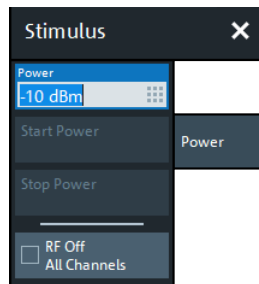

Power

Determines the output power at the test ports for the sweep types "Lin Freq", "Log Freq", "CW Mode", and "Time". Also determines the default output power for "Segmented" sweeps, where the output power can be set per segment.

The setting has no effect for **Power** sweeps, where the source power is varied over a continuous range.

Remote command:

```
SOURce<Ch>:POWER<PhyPt>[:LEVEL][:IMMEDIATE][:AMPLITUDE]
```

Start Power / Stop Power

Defines the sweep range for **Power** sweeps.

Remote command:

```
SOURce<Ch>:POWER<PhyPt>:START
```

```
SOURce<Ch>:POWER<PhyPt>:STOP
```

RF Off All Channels

"RF Off All Channels" switches the internal power source for all channels off (if checked) or on. Switching off the RF power helps to prevent overheating of a connected DUT while no measurement results are taken.

Remote command:

```
OUTPut<Ch>[:STATE]
```

6.8.3 Time Domain X-Axis Tab

If the active trace is a time domain trace, these settings define its stimulus axis.



Time domain analysis requires option R&S ZND-K2. If this option is not installed, the "Time Domain X-Axis" tab is hidden.



Related information

Refer to the following sections:

- [Chapter 5.7.5, "Time Domain Analysis"](#), on page 193
- [Chapter 6.5.5, "Time Domain Tab"](#), on page 279

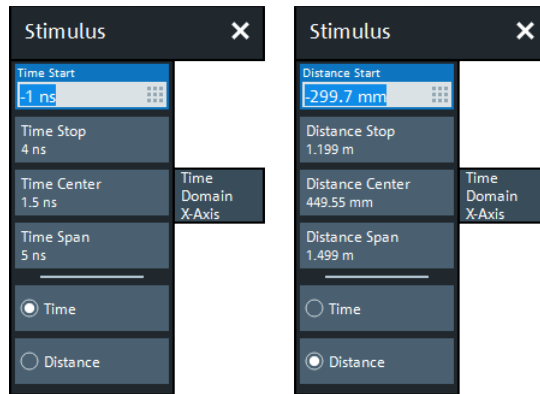

Figure 6-6: Stimulus > Time Domain X-Axis softtool tab

left = Time representation
right = Distance representation

Time Start / Time Stop / Time Center / Time Span

Defines the display range for the time domain trace in time representation (see "Time / Distance" on page 349).

- "Time Start" is the lowest displayed time and corresponds to the left edge of the Cartesian diagram.
- "Time Stop" is the highest displayed time and corresponds to the right edge of the Cartesian diagram.
- "Time Center" corresponds to the center of the Cartesian diagram, i.e. ("Time Start" + "Time Stop")/2.
- "Time Span" corresponds to the diagram width, i.e. ("Time Stop" – "Time Start").

"Time Start" and "Time Stop" or "Time Center" and "Time Span" are alternative settings.

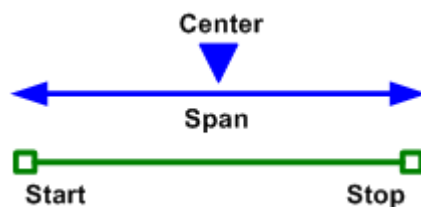

Remote command:

```
CALCulate<Chn>:TRANSform:TIME:START
CALCulate<Chn>:TRANSform:TIME:STOP
CALCulate<Chn>:TRANSform:TIME:CENTer
CALCulate<Chn>:TRANSform:TIME:SPAN
```

Distance Start / Distance Stop / Distance Center / Distance Span

Defines the display range for the time domain trace in distance representation (see "Time / Distance" on page 349).

"Distance Start" and "Distance Stop" or "Distance Center" and "Distance Span" are alternative settings.

Remote command:

n.a.

See ["Time Start / Time Stop / Time Center / Time Span"](#) on page 348.

Time / Distance

"Time" and "Distance" switch over between the x-axis scaling in time units or distance units.

The interpretation of time and distance depends on the measurement type. For reflection measurements (S-parameters S_{ii} or ratios with equal port indices), the time axis represents the propagation time of a signal from the source to the DUT and back. For transmission measurement, it represents the propagation time from the source through the device to the receiver.

The distance between the source and the DUT is calculated from the propagation time, the velocity of light in the vacuum, and the velocity factor of the receiving port:

- $Distance = \langle Time \rangle * c_0 * \langle Velocity Factor \rangle$ for transmission measurements
- $Distance = 1/2 * \langle Time \rangle * c_0 * \langle Velocity Factor \rangle$ for reflection measurements. The factor 1/2 accounts for the return trip from the DUT to the receiver.

The velocity factor of the receiving port can be defined using CHANNEL – [OFF-SET EMBED] > "Offset" (see [Chapter 6.13.2.1, "Controls on the Offset Tab"](#), on page 444).

Remote command:

`CALCulate<Chn>:TRANSform:TIME:XAXis`

6.9 Power Bw Avg Softtool

The "Power Bw Avg" softtool allows you to configure the signal power, to set up the IF signal processing, and to configure the averaging logic.

Access: CHANNEL – [PWR BW AVG] hardkey

6.9.1 Power Tab

The "Power" tab allows you to configure the signal power. It is identical to the "Stimulus" > "Power" tab; see [Chapter 6.8.2, "Power Tab"](#), on page 346.

6.9.2 Bandwidth Tab

Sets the measurement bandwidth for the active channel

A system error correction (calibration) remains valid when the filter settings are changed.



Optimizing the filter settings

A small bandwidth suppresses the noise level around the measurement frequency and thus increases the dynamic range. However, the measurement time increases with smaller filter bandwidths. For small bandwidths, the filter settling time, which is inversely proportional to the bandwidth, is responsible for the predominant part of the measurement time.



Segmented sweeps

In segmented frequency sweeps, the filter settings can be selected independently for each segment. see [Chapter 6.10.2.2, "Define Segments Dialog"](#), on page 360.

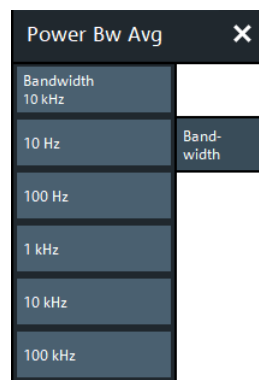

Bandwidth

"Bandwidth" the measurement bandwidth of the IF filter. Within the value range, the entered value is rounded up to $1 \cdot 10^n$ Hz, $1.5 \cdot 10^n$ Hz, $2 \cdot 10^n$ Hz, $3 \cdot 10^n$ Hz, $5 \cdot 10^n$ Hz, $7 \cdot 10^n$ Hz ($n \geq 0$). Values exceeding the maximum bandwidth are rounded down.

The bandwidth range is 1 Hz to 300 kHz.

Remote command:

```
[SENSe<Ch>:]BANDwidth[:RESolution]
[SENSe<Ch>:]BWIDth[:RESolution]
```

6.9.3 Average Tab

Defines the number of consecutive sweeps to be averaged and enables/disables the sweep average.



Effects of sweep averaging, alternative settings

An average over several sweeps reduces the influence of random effects in the measurement and therefore minimizes the noise level. The effect increases with the average factor, however, obtaining an averaged result requires several sweeps and therefore increases the measurement time.

Smoothing is an alternative method of compensating for random effects on the trace by averaging adjacent measurement points. Compared to the sweep average, smoothing does not significantly increase the measurement time but can eliminate narrow peaks and thus produce misleading results.

The sweep average is not frequency selective. To eliminate a spurious signal near the measurement frequency, alternative techniques (e.g. a smaller filter bandwidth) must be used.



The average factor is also valid for calibration sweeps. The calculation of system correction data is based on the averaged trace.

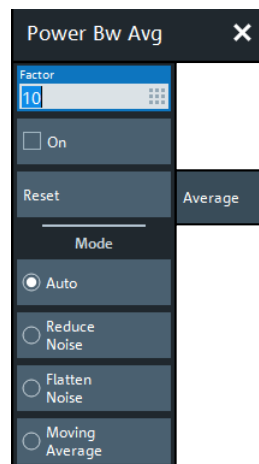

Factor / On / Reset

"Factor" defines the number of averaged traces, "On" enables or disables the sweep average, "Reset" starts a new average cycle. The average cycle is also restarted when the [averaging mode](#) is changed.

Remote command:

```
[SENSe<Ch>:] AVERAge: COUNT
[SENSe<Ch>:] AVERAge [ : STATe]
[SENSe<Ch>:] AVERAge: CLear
```

Mode

Selects one of the following averaging algorithms:

- **"Auto"**: Automatic selection between **"Reduce Noise"** and **"Flatten Noise"** mode, depending on the trace type.
- **"Reduce Noise"**: Cumulative moving averages of the real and imaginary parts of each measurement result, provides the most effective noise suppression for the "Real" and "Imag" formats and for polar diagrams.

- **"Flatten Noise"**: Cumulative moving averages of the (linear) magnitude and phase values, provides the most effective noise suppression for the "dB Mag", "Phase", "Unwr. Phase", and "Lin Mag" formats.
- **"Moving Average"**: Simple moving averages of the real and imaginary parts of each measurement result; similar to "Reduce Noise", but with finite history.

Changing the mode resets the average cycle.

Remote command:

```
[SENSe<Ch>: ] AVERAge :MODE
```

6.10 Sweep Softtool

The "Sweep" softtool allows you to define the scope of the measurement in the active channel.

The available settings comprise the sweep type (with related parameters), the trigger conditions, and the periodicity of the measurement.

Access: CHANNEL – [SWEEP] hardkey



Background information

Refer to the following sections:

- [Chapter 5.1.4, "Sweep Control"](#), on page 72
- [Chapter 5.1.4.4, "Stimulus and Sweep Types"](#), on page 76

6.10.1 Sweep Params Tab

Allows you to define the scope and timing of the measurement in the active channel.



Segmented sweeps

In "Segmented" linear frequency sweeps, the sweep parameters can be set independently for each segment. See [Chapter 6.10.2.2, "Define Segments Dialog"](#), on page 360.



System error correction

In general, the system error correction is no longer valid after a change of the sweep parameters. The status of the calibration is shown in the trace list. If the number of points is changed, the analyzer interpolates the correction data. The calibration label "Cal Int" is displayed. See also [Chapter 5.5.4, "Calibration Labels"](#), on page 158.

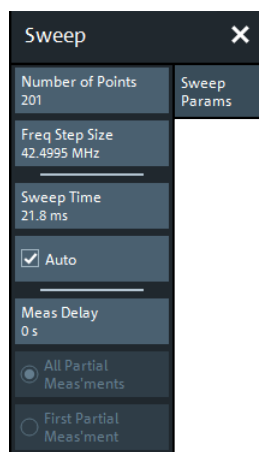

Number of Points

Sets the total number of measurement points per sweep. The minimum number of points is 1 (measurement at a single frequency/power/time value). The maximum depends on the analyzer type.

Sets the total number of measurement points per sweep. The minimum number of points is 1 (measurement at a single frequency/power/time value), the maximum is 5,001.

Together with the sweep range defined in the [Stimulus Tab](#) of the "Stimulus" softtool, this parameter defines the grid of sweep points. The step width between two consecutive sweep points is constant on a linear scale (sweep types "Lin Freq", "Time" and "CW Mode") or on a logarithmic scale (sweep types "Log Freq" and "Power").

The sweep points for linear frequency sweeps can also be defined using the [Freq Step Size](#).

Tip: Measurement time and screen resolution

Increasing the number of sweep points improves the resolution of the trace but increases the measurement time. The overall measurement time is composed of the hardware settling time at the beginning of the sweep plus the sum of the measurement times at each individual sweep point. Hence the measurement time increases roughly linearly with the number of points.

See also [Chapter 5.1.4, "Sweep Control"](#), on page 72.

Remote command:

```
[SENSe<Ch>:] SWEEp: POINTs
```

Freq Step Size

Sets the distance between two consecutive sweep points of a linear frequency sweep.

For linear frequency sweeps the step size is an alternative to the [Number of Points](#) setting:

- If the sweep range is defined via "Start Frequency" and "Stop Frequency", both the "Stop Frequency" value and the "Number of Points" can vary as the "Freq Step Size" is changed. The "Stop Frequency" value is changed as little as possible so that the condition $\text{"Freq Step Size"} = (\text{"Stop Frequency"} - \text{"Start Frequency"}) / (\text{"Number of Points"} - 1)$

can be fulfilled. Changing the "Start Frequency" and "Stop Frequency" modifies the "Freq Step Size".

- If the sweep range is defined via "Center Frequency" and "Span Frequency", both the "Span Frequency" value and the "Number of Points" can vary as the "Freq Step Size" is changed. The "Span Frequency" is reduced as little as possible so that the condition $\text{"Freq Step Size"} = \text{"Span Frequency"} / (\text{"Number of Points"} - 1)$ can be fulfilled. Changing the "Span Frequency" modifies the "Freq Step Size".

Note:

- This setting is valid for linear frequency sweeps only. It does not apply to logarithmic and segmented sweeps, power, time or CW mode sweeps.
- Decreasing the "Freq Step Size" generally increases the measurement time.

Remote command:

```
[SENSe<Ch>:] SWEep:STEP
```

Sweep Time / Auto

Varies the measurement time for a sweep or delays the start of each sweep.

- "Sweep Time" is the total measurement time for the sweep. The minimum possible sweep time is equal to the estimated value in "Auto" mode. Setting a larger sweep time is equivalent to defining a [Meas Delay](#) before each partial measurement.
- "Auto" minimizes the sweep time. The [Meas Delay](#) is set to 0 s. "Sweep Time" indicates the estimated sweep time, depending on the current measurement settings. The "Sweep Time" and "Meas Delay" values are maintained until changed explicitly if "Auto" is switched off.

If a time sweep is active, "Sweep Time" cannot be modified. The analyzer uses the previously defined sweep time settings.

Remote command:

```
[SENSe<Ch>:] SWEep:TIME
```

```
[SENSe<Ch>:] SWEep:TIME:AUTO
```

Meas Delay

Adds a delay time before the start of every partial measurement. See [Chapter 5.1.4.1, "Partial Measurements and Driving Mode"](#), on page 73 .

"Meas Delay" is not available while a "Time" or "CW Mode" sweep is active.

As an alternative to increasing the delay (and thus the total sweep time), it is possible to select "Alternated" driving mode; see ["Driving Mode"](#) on page 433.

Remote command:

```
[SENSe<Ch>:] SWEep:DWELL
```

All Partial Meas'ments / First Partial Meas'ment

If [Meas Delay](#) is set to a value > 0, this setting allows you to define how the measurement delay is applied:

- If "All Partial Meas'ments" is selected, the delay time is added before each partial measurement. For a complete 2 port S-parameter measurement, the delay must be added twice per sweep point.
- If "First Partial Meas'ment" is selected, the delay time is added once per sweep point only, irrespective of the measured quantities and the number of partial mea-

surements. The sweep time increases by the measurement delay times the number of sweep points.

Tip: A delay time before the start of each partial measurement increases the accuracy, in particular for measurements on DUTs with long settling times (e.g. quartz oscillators, SAW filters). Select "First Partial Meas'ment" if the DUT does not require an additional settling time due to the interchange of source and receive ports.

Remote command:

```
[SENSe<Ch>:]SWEep:DWELl:IPoint
```

6.10.2 Sweep Type Tab

Defines the sweep variable (frequency/power/time) and the position of the sweep points across the sweep range.

6.10.2.1 Controls on the Sweep Type Tab

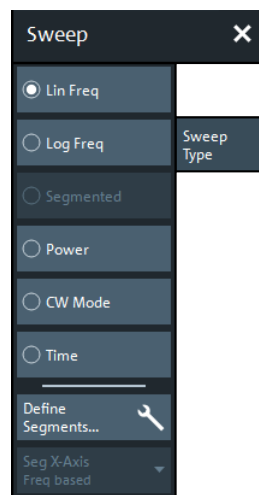

Lin Freq

In a linear frequency sweep, the stimulus frequency is swept in equidistant steps over the continuous frequency range. The frequency range (sweep range) and the internal generator power can be specified in the "Stimulus" settings (see [Chapter 6.8.1, "Stimulus Tab"](#), on page 345). The step width between two consecutive sweep points is constant and given by $\text{Span}/(n - 1)$ where n is the specified "Number of Points" ($n > 1$).

"Lin Freq" is the default sweep type. In a Cartesian diagram, the measurement result is displayed as a trace over a linear frequency scale (as known, e.g., from spectrum analyzers). The following example shows a "Lin Freq" sweep with the forward transmission parameter S_{21} as measured quantity, and a "dB Mag" scaled y-axis.

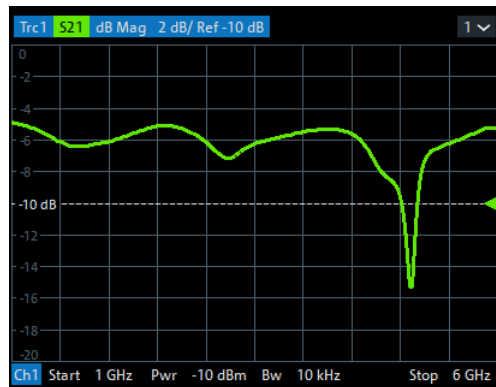

Remote command:

```
[SENSe<Ch>:]SWEep:TYPE LINear
```

Log Freq

In a "Log Freq" sweep, the stimulus frequency is swept on a logarithmic scale over the continuous frequency range. The frequency range (sweep range) and the internal generator power can be specified in the "Stimulus" settings (see [Chapter 6.8.1, "Stimulus Tab"](#), on page 345). The sweep points are calculated from the "Span" and the specified "Number of Points" ($n > 1$) with the condition that the step width is constant on the logarithmic scale.

"Log Freq" sweeps are suitable for the analysis of a DUT over a large frequency range, e.g. over several octaves. In a Cartesian diagram, the measurement result is displayed as a trace over a logarithmic frequency scale. The following example shows a "Log Freq" sweep with the forward transmission parameter S_{21} as measured quantity, and a "dB Mag" scaled y-axis.

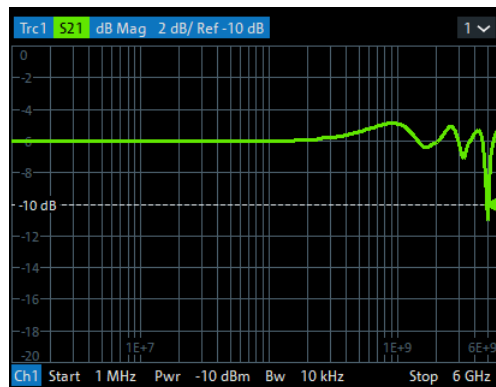

Tip: In "Log Freq" representation, limit lines and ripple limit lines appear as exponential curves; see [Chapter 5.4.1.1, "Rules for Limit Line Definition"](#), on page 123.

Remote command:

```
[SENSe<Ch>:]SWEep:TYPE LOGarithmic
```

Segmented

In a "Segmented" (linear) frequency sweep, the sweep range can be composed of several continuous frequency sub-ranges or single frequency points. The sub-ranges are termed sweep segments and are defined in the [Define Segments Dialog](#).

Sweep segments can overlap. The segment list must contain at least 2 distinct frequency points before a segmented frequency sweep can be started.

Instrument settings such as the internal generator power, the measurement (IF) bandwidth, and the frequency band of the local oscillator can be set independently for the individual segments.

Due to this flexibility, segmented frequency sweeps are suitable for any detailed analysis of a DUT at specified frequencies. In a Cartesian diagram, the measurement result is displayed as a trace over a linear frequency scale ranging from the lowest to the highest frequency point of all segments. The following example shows a segmented frequency sweep with 2 segments. The forward transmission parameter S_{21} is measured, and a "dB Mag" scaled y-axis is used. In the frequency range between the sweep segments, the trace is displayed as a straight line.

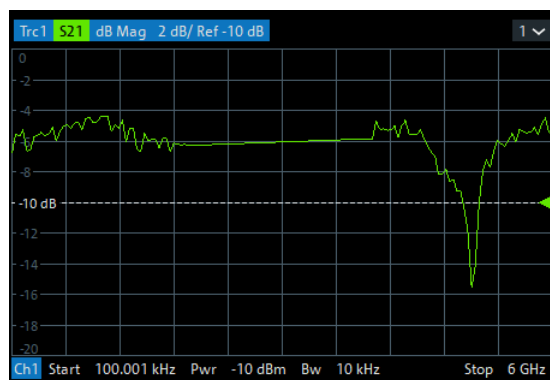

Tip: You can change to point based x-axis to improve the display of a segmented frequency sweep (see "[Seg X-Axis](#)" on page 359).

Remote command:

```
[SENSe<Ch>:] SWEEP:TYPE SEGMENT
```

Power

In a "Power" sweep, the internal generator power is swept in dB-linear, equidistant steps over a continuous power range. The generator power range (sweep range) and the fixed frequency can be specified in the "Stimulus" settings (see [Chapter 6.8.1, "Stimulus Tab"](#), on page 345).

"Power" sweeps are particularly suitable for the analysis of non-linear effects (saturation, compression) on active and passive DUTs (e.g. power amplifiers, mixers).

In a Cartesian diagram, the measurement result is displayed as a trace over a dB-linear power scale. The following example shows a "Power" sweep in the source power range between -25 dBm and 0 dBm, performed at a CW frequency of 1 GHz.

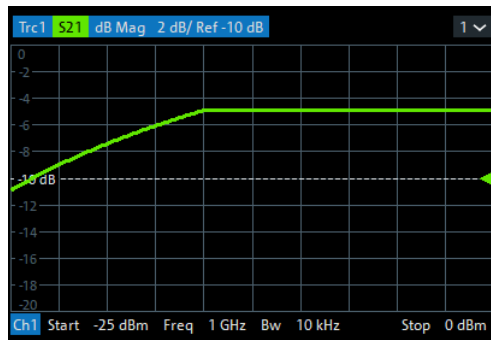

Remote command:

```
[SENSe<Ch>:] SWEEp:TYPE PWEr
```

CW Mode

"CW Mode" sweeps, like [Time](#) sweeps, are performed at constant frequency and stimulus power, which can be specified in the "Stimulus" settings (see [Chapter 6.8.1, "Stimulus Tab"](#), on page 345).

The measurement is triggered according to the current trigger settings (see [Chapter 6.10.3, "Trigger Tab"](#), on page 365). Each trigger event triggers the first partial measurement of a measurement point. The time interval between two consecutive measurements depends on the trigger settings and the sweep parameters (especially the number of points). Any trigger mode is allowed.

A "CW Mode" sweep corresponds to the analysis of a signal over the time with a time scale and resolution that is determined by the trigger events. In a Cartesian diagram, the measurement result is displayed as a trace over a linear time scale (like, e.g., in an oscilloscope). The diagram is similar to the "Time" diagram. The following example shows a "CW Mode" sweep with a DUT that does not markedly change its transmission characteristics over the time.

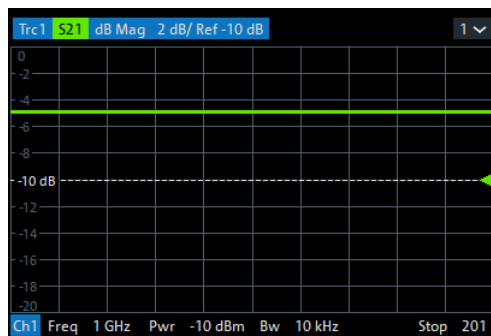

Tip: Sweep time

The time interval between two consecutive trigger pulses must not be smaller than the minimum measurement time per measurement point. See ["Sweep Time / Auto"](#) on page 354.

Remote command:

```
[SENSe<Ch>:] SWEEp:TYPE POINT
```

Time

"Time" sweeps, like [CW Mode](#) sweeps, are performed at constant frequency and stimulus power, which can be specified in the "Stimulus" settings (see [Chapter 6.8.1, "Stimulus Tab"](#), on page 345). A single sweep extends over a specified period of time, defined via the "Stop Time" setting. The time intervals between two consecutive sweep points are calculated according to "Stop Time"/($n - 1$) where n is the selected [Number of Points](#).

A "Time" sweep corresponds to the analysis of a signal over the time; the function of the analyzer is analogous to an oscilloscope. In a Cartesian diagram, the measurement result is displayed as a trace over a linear time scale. The following example shows a "Time" sweep with a DUT that does not markedly change its transmission characteristics over the time.

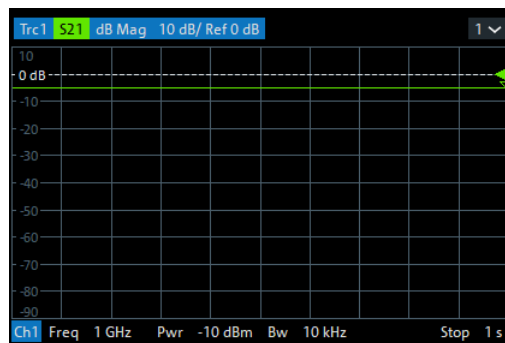

Tip: Sweep time

The minimum sweep time depends on the number of measurement points, the measurement bandwidth, the delay time before each partial measurement and the number of partial measurements required for each measurement point. The analyzer estimates this time, based on the current measurement settings.

If the "Stop Time" is smaller than the estimated minimum sweep time, the entered value is increased automatically.

Equidistance of sweep points

The analyzer tries to keep the time intervals between any two consecutive time sweep points equal: The time sweep samples are equidistant. Equidistance also holds for sweeps which range over several channels.

Remote command:

```
[SENSe<Ch>:] SWEEp:TYPE CW
```

Define Segments...

Opens the [Define Segments Dialog](#) that allows to set up the channel for a [Segmented](#) frequency sweep.

Seg X-Axis

Scales the x-axis for a segmented frequency sweep:

- In "Freq based" mode, the x-axis covers the frequency ranges of all sweep segments, including possible gaps between the segments. Equal frequency spacings correspond to equal distances on the x-axis.

- In "Point based" mode, the x-axis shows all sweep points with equal spacings. Gaps between sweep segments are minimized; no diagram space is "wasted" on unused frequency ranges. Point-based mode is indicated in the channel line.

The example below shows a segmented frequency sweep with two segments. The first segment ranges from 1 GHz to 1.4 GHz; the second segment from 2 GHz to 3 GHz. Both segments contain 11 sweep points. In point-based mode (lower diagram), all sweep points are equidistant.

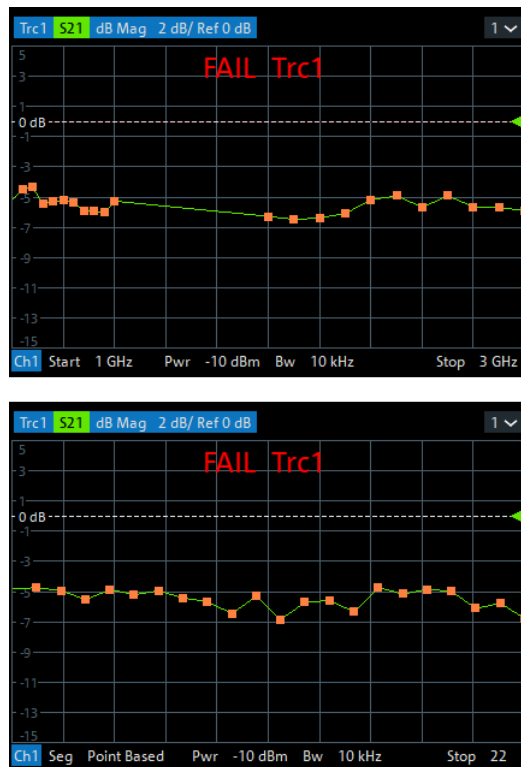

Tip: Overlapping limit line and ripple limit line segments are not displayed when a point-based x-axis is active; see [Chapter 5.4.1.1, "Rules for Limit Line Definition"](#), on page 123.

Remote command:

`[SENSe<Ch>:] FREQuency: SEGment: AXIS`

6.10.2.2 Define Segments Dialog

The "Define Segments" dialog defines all channel settings for a [Segmented](#) frequency sweep and imports or exports segmented sweep settings.

Access: CHANNEL – [SWEEP] > "Sweep Type" > "Define Segments..."

The dialog contains a table to edit the individual segments of the sweep range. Use the [Displayed Columns Dialog](#) to select the columns to be displayed and edited.



- Sweep segments are allowed to overlap.
- In contrast to standard frequency sweeps, the start and stop frequency in a sweep segment do not have to be different.
So with a segmented sweep you can measure n_1 points at frequency f_1 (in segment 1), n_2 points at frequency f_2 (in segment 2) etc.

Controls in the Define Segments Dialog

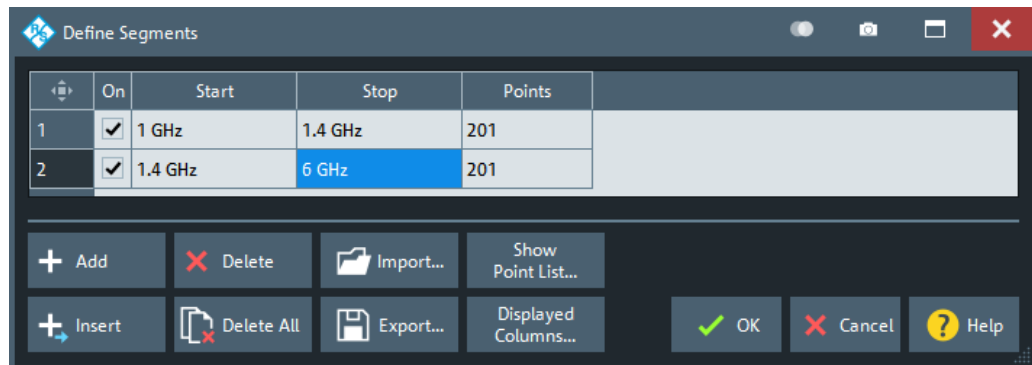

Table Columns

The table in the upper part of the "Define Segments" dialog contains an automatically assigned current number for each segment plus the following editable or non-editable columns:

- "On" provides check boxes to activate or deactivate each individual segment. Sweep points in inactive segments are not measured and not listed in the "Point List".
- "Start" is the stimulus (x-axis) value of the first point of the segment.
- "Stop" is the stimulus (x-axis) value of the last point of the segment.
- "Points" is the number of sweep points in the segment. A single segment can consist of only one point. If "Points" is set to 1, then the "Stop" frequency is set equal to the "Start" frequency.

Note: Displayed Columns and Segment-specific Measurement Settings

The remaining columns allow you to replace channel-wide measurement settings by segment-specific ones. These columns are only displayed – and the corresponding segment-specific values are only applied – if they are selected in the [Displayed Columns Dialog](#).

Note: Limitations for overlapping segments

When overlapping sweep segments are created, the marker functions, trace evaluation functions, trace search functions and band filter functions are still available. It is possible, however, that these tools show an unexpected behavior when used in overlapping sweep segments. The reason is that the assignment of markers to traces in overlapping segments is ambiguous. If you want to analyze a particular segment using markers, turn "Off" all sweep segments that overlap with this segment.

Remote command:

```
[SENSe<Ch>:] SEGMENT:COUNT?
[SENSe<Ch>:] SEGMENT<Seg>[:STATE]
```

```
[SENSe<Ch>:] SEGMENT<Seg>:FREQUency:START
[SENSe<Ch>:] SEGMENT<Seg>:FREQUency:STOP
[SENSe<Ch>:] SEGMENT<Seg>:FREQUency:CENTer?
[SENSe<Ch>:] SEGMENT<Seg>:FREQUency:SPAN?
[SENSe<Ch>:] SEGMENT<Seg>:SWEep:POINTs
```

Add / Insert / Delete / Delete All

The four buttons below the segment list extend or shorten the list.

- "Add" adds a new segment to the end of the list.
The added segment covers a possible frequency gap between the preceding segment and the upper frequency limit of the analyzer. The "Start" frequency of the new segment is set equal to the "Stop" frequency of the preceding segment. The "Stop" frequency is equal to the upper frequency limit. The number of points is the same as the number of points of the preceding segment.
- "Insert" inserts a new segment before the active segment. The segment numbers of all segments after the new segment are incremented by one.
The new segment covers a possible frequency gap between the two adjacent segments. A new segment which is inserted before segment no. 1 starts at the lower frequency limit of the analyzer. The number of points is the same as the number of points of the next segment.
- "Delete" removes the selected segment from the list.
- "Delete All" clears the entire segment list so it is possible to define or load a new segmented sweep range.

Remote command:

```
[SENSe<Ch>:] SEGMENT<Seg>:ADD
[SENSe<Ch>:] SEGMENT<Seg>:INSert
[SENSe<Ch>:] SEGMENT<Seg>:DELete [:DUMMy]
[SENSe<Ch>:] SEGMENT<Seg>:DELete:ALL
```

Show Point List...

Opens a list of all active sweep points and their channel settings. All columns except "Point", "Segment" and "Frequency" are displayed only if they are explicitly selected; see "[Displayed Columns Dialog](#)" on page 363.

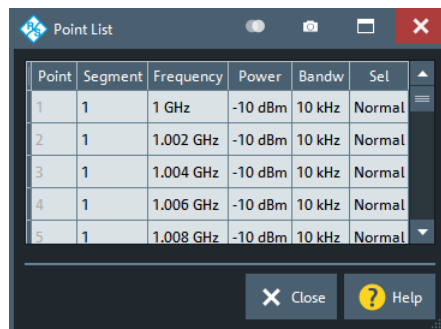

Point	Segment	Frequency	Power	Bandw	Sel
1	1	1 GHz	-10 dBm	10 kHz	Normal
2	1	1.002 GHz	-10 dBm	10 kHz	Normal
3	1	1.004 GHz	-10 dBm	10 kHz	Normal
4	1	1.006 GHz	-10 dBm	10 kHz	Normal
5	1	1.008 GHz	-10 dBm	10 kHz	Normal

Close Help

Figure 6-7: Point List

Import.../ Export...

The buttons open standard dialogs to import/export sweep segment settings to/from an ASCII file (*.SegList).

- "Import..." replaces the current segment list by a sweep segment list loaded from a *.SegList file.
- "Export..." stores the current sweep segments settings to a *.SegList file.

Sweep segment files

The analyzer uses a simple ASCII format to export sweep segment data. By default, the sweep segment file extension is *.SegList. The file starts with two comment lines containing the version and a third line reproducing the header of the segment list. The following lines contain the entries of all columns of the segment list, including the "Displayed Columns" that are configured in the "Define Segments" dialog.

Example:

The segmented sweep range

	Name	On	Start	Stop	Points	Pwr (Pb)	Bandw
1	Low	<input checked="" type="checkbox"/>	1 GHz	2 GHz	11	-10 dBm	10 kHz
2	High	<input checked="" type="checkbox"/>	2 GHz	3 GHz	11	-10 dBm	10 kHz

is described by the following sweep segment file:

```
# Version 1.00
#
bo:State,str:Name,Start Frequency[MHz],Stop Frequency[MHz],int:No of Points,Source Power [dBm],IF Bandwidth[Hz]
true,Low,1.000000000000000E+003,2.000000000000000E+003,11,-1.000000000000000E+001,1.000000000000000E+004,Normal
true,High,2.000000000000000E+003,3.000000000000000E+003,11,-1.000000000000000E+001,1.000000000000000E+004,Normal
```

Note: The *.SegList file actually contains more columns listing all channel settings of the individual sweep segments. The headings of the additional columns are *IF Bandwidth [Hz]*, *en:IF Selectivity*, *en:IF Sideband*, *Meas Delay [μs]*, *bo:Sweep Time Auto*, *en:Frq Sweep Mode*.

The R&S ZND only supports the "Stepped" frequency sweep mode. Hence the content of the last column is always *Stepped*. During import, other values are silently replaced.

Remote command:

[MMEMory:LOAD:SEGMENT](#)

[MMEMory:STORe:SEGMENT](#)

Displayed Columns Dialog

The "Displayed Columns" dialog allows you to select the channel settings that can be defined per sweep segment. These settings are displayed in the [Define Segments Dialog](#) and in the "Point List" (opened via [Show Point List...](#)).

Access: [Define Segments Dialog](#) > "Displayed Columns..."

All segment-specific settings can be modified in the "Define Segments" dialog. By default, the first sweep segment is created with the channel settings defined for unsegmented sweep types. When any further sweep segment is created, it uses the channel settings of the previously active segment.



Related information

Refer to the following sections:

- [Chapter 6.10.2.2, "Define Segments Dialog"](#), on page 360
- ["Show Point List..."](#) on page 362

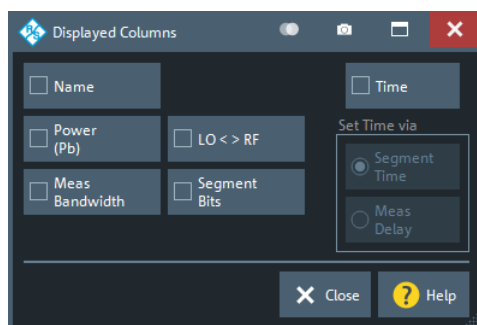

Optional Columns

Each selected (checked) option adds a column to the segment list and the point list.

- "Name" allows you to assign a name to each segment. A segment name is a string that is allowed to contain letters, numbers and special characters.
- "Power (Pb)" allows you to define the internal source power (channel base power) for each individual sweep segment. See ["Power"](#) on page 347.
- "Meas Bandwidth" defines the IF filter bandwidth for each individual sweep segment. See ["Bandwidth"](#) on page 350.
- **Note:** For the R&S ZND this control is always disabled.
- "Segment Bits" enables the definition of a segment-dependent 4-bit binary value to control four independent output signals at the USER PORT connector (lines 16, 17, 18, 19; see [Chapter 11.3.1.1, "USER PORT"](#), on page 1156). The output signals are 3.3 V TTL signals which can be used to differentiate between up to 16 independent analyzer states.

For an application example, refer to the detailed remote control description (`OUTPut<Ch>:UPORt:SEGment<Seg>[:VALue]`).

Setting the segment bits does not change the analyzer state.

- "Time" defines the sweep time for each segment. The default configuration for a new segment is equal to the sweep time setting for unsegmented sweeps; see ["Sweep Time / Auto"](#) on page 354.

When "Time" is checked, two new columns appear in the table. The first column is titled "Segment Time" or "Meas Delay", depending on the selected radio button below the "Time" checkbox. The second column is titled "Auto" and is used to activate automatic sweep time setting.

"Segment Time" is the total measurement time for the sweep segment. The minimum segment sweep time to be set is equal to the estimated value in "Auto" mode. "Meas Delay" sets a delay time allowing the DUT to settle before the hardware settings of the analyzer are changed and a new partial measurement is started.

Changing the "Meas Delay" modifies the "Segment Time" and vice versa.

"Auto" minimizes the sweep time. If "Auto" is selected for a segment, the columns "Segment Time" or "Meas Delay" (in the "Define Segments" dialog cannot be edited). "Segment Time" indicates the estimated sweep time, depending on the cur-

rent measurement settings, the "Meas Delay" is 0 s. The segment sweep time and point delay values are maintained until changed explicitly if "Auto" is switched off.

Remote command:

```
[SENSe<Ch>:] SEGMENT<Seg>:POWER[:LEVEL]:CONTROL
[SENSe<Ch>:] SEGMENT<Seg>:POWER[:LEVEL]
[SENSe<Ch>:] SEGMENT<Seg>:BWIDth[:RESolution]
[SENSe<Ch>:] SEGMENT<Seg>:BWIDth[:RESolution]:CONTROL
[SENSe<Ch>:] SEGMENT<Seg>:DEFine
[SENSe<Ch>:] SEGMENT<Seg>:DEFine:SElect
[SENSe<Ch>:] SEGMENT<Seg>:INSert
[SENSe<Ch>:] SEGMENT<Seg>:INSert:SElect
[SENSe<Ch>:] SEGMENT<Seg>:SWEep:DWELl
[SENSe<Ch>:] SEGMENT<Seg>:SWEep:DWELl:CONTROL
[SENSe<Ch>:] SEGMENT<Seg>:SWEep:TIME
[SENSe<Ch>:] SEGMENT<Seg>:SWEep:TIME:CONTROL
[SENSe<Ch>:] SEGMENT<Seg>:SWEep:TIME:SUM?
OUTPut<Ch>:UPORt:SEGMENT<Seg>:STATe
OUTPut<Ch>:UPORt:SEGMENT<Seg>[:VALue]
CONTROL:AUXiliary:C[:DATA]
```

6.10.3 Trigger Tab

Selects the source of the trigger signal and provides additional trigger settings.

Trigger system of the analyzer

The trigger system is used to synchronize the analyzer's actions with events that can be provided by an internal or external signal or user-generated ("Manual Trigger"). Triggered measurements are an alternative to the default mode ("FreeRun", "Continuous" sweep), where the measurement is continuously repeated without fixed time reference.

Any trigger event can start an entire sweep or a part of it. Moreover, it is possible to switch off the RF source between consecutive triggered measurement sequences, and to define a delay between trigger events and the measurement sequences.



Background information

Refer to [Chapter 5.1.4.1, "Partial Measurements and Driving Mode"](#), on page 73.

Output trigger

The R&S ZND provides a configurable output trigger signal to synchronize external devices with the measurement. This signal is available at the rear panel connector EXT TRIG OUT. Configuration of the output trigger signal is a remote control feature (TRIGger:CHANnel<Ch>:AUXiliary... commands; see [Chapter 8.3.19, "TRIGGER Commands"](#), on page 1060).

6.10.3.1 Controls on the Trigger Tab



The trigger settings are also valid for calibration sweeps. Hence, in external trigger mode, the external trigger signal must be available during the system error correction, too. To start the calibration sweeps without delay, use the "FreeRun" trigger type.

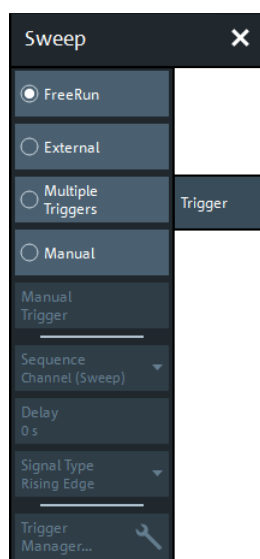

The following buttons in the "Trigger" tab open related dialogs:

- **"Trigger Manager...":** [Trigger Manager Dialog](#)

FreeRun / External / Manual / Multiple Triggers

These four buttons select the trigger source:

- In "FreeRun" mode, a new measurement is started immediately without waiting for a trigger event and without fixed time reference. The remaining trigger settings are not valid.
"FreeRun" means that a measurement in "Continuous" sweep mode is repeated as fast as possible.
- In "External" trigger mode, the measurement is triggered by an external 5 V TTL signal, applied to one of the following rear panel connectors:
 - BNC connector EXT TRIG IN
 - Pin 2 of the USER PORT connector
 - Pin 18 of the [Handler I/O \(Universal Interface\)](#)

The trigger inputs are equivalent; no additional setting for signal routing is required. For detailed specifications of the trigger signals, refer to [Chapter 11.3.1.1, "USER PORT"](#), on page 1156.

The "External" trigger mode can be configured using the [Sequence](#), [Delay](#) and [Signal Type](#) settings.

- In "Manual" trigger mode, the trigger signal is generated by the "Manual Trigger" button.

- If "Multiple Triggers" is active, the trigger sources for different triggered measurement sequences, the trigger slope, and the trigger delay can be selected individually using the [Trigger Manager Dialog](#).
In particular, it is possible to use different external trigger sources.

Remote command:

```
TRIGger<Ch>[:SEquence]:SOURce EXTernal
```

Manual Trigger

Generates the trigger event for "Manual" trigger mode and is disabled unless this mode is active.

Remote command:

```
TRIGger<Ch>[:SEquence]:SOURce MANual
```

```
*TRG
```

Sequence

Selects the measurement cycle or sequence of actions to be triggered in "External" or "Manual" mode.

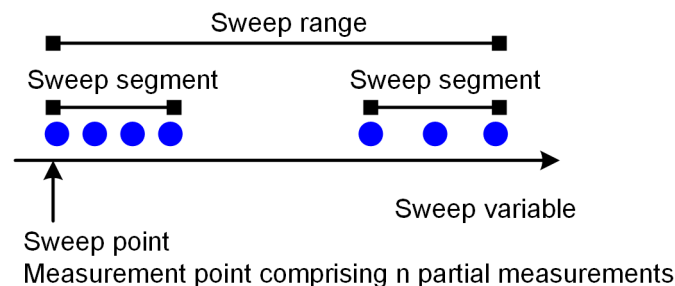

- "Sweep" means that each trigger event starts an entire sweep, according to the current sweep configuration.
- "Point" means that each trigger event starts the measurement at the next sweep point.
- "Partial Measurement" means that each trigger event starts the next partial measurement at the current or at the next sweep point. If every sweep point only requires a single partial measurement, this option is equivalent to "Point".
See also [Chapter 5.1.4.1, "Partial Measurements and Driving Mode"](#), on page 73.
- "Segment" means that each trigger event starts the next sweep segment within the current sweep. If a sweep type other than [Segmented](#) is active, this option is equivalent to "Sweep".

Relation with other sweep settings

Some sweep settings are logically incompatible with a particular selection of the triggered measurement sequence:

- If a [Time](#) sweep is performed, the sequence is always a sweep.
- "Alternated" [Driving Mode](#) only makes sense if the triggered measurement sequence comprises more than one sweep point. If "Point" or "Partial Measurement" is selected, "Alternated" mode is switched off and vice versa.

Note: The trigger events must be adjusted to the triggered measurement sequence. If the analyzer receives a trigger event while the last sequence is still running, the R&S ZND skips the trigger event and generates a message.

Remote command:

```
TRIGger<Ch>[:SEquence]:LINK
```

Delay

Specifies a delay time between the trigger event and the start of the next measurement sequence.

The specified "Delay" must be zero or positive, so that the trigger event precedes the start of the measurement (post-trigger).

If "Multiple Triggers" is active, the "Delay" can be selected individually using the [Trigger Manager Dialog](#).

Remote command:

```
TRIGger<Ch>[:SEquence]:HOLDoff
```

Signal Type

Specifies the "External" trigger mode in detail.

- **"Rising Edge"/"Falling Edge"** means that the rising/falling slope of every external trigger pulse can trigger a single measurement sequence.
- **"Active High"/"Active Low"** means that the analyzer measures in "FreeRun" mode as long as the external trigger signal is high/low. The measurement is discontinued when the trigger signal changes to low/high.

Remote command:

```
TRIGger<Ch>[:SEquence]:SLOPe
```

6.10.3.2 Trigger Manager Dialog

The "Trigger Manager" dialog defines individual trigger sources and delays for the triggered measurement sequences. The dialog is available and its settings are valid if the analyzer is configured for "Multiple Triggers" (see ["FreeRun / External / Manual / Multiple Triggers"](#) on page 366).

Access: CHANNEL – [TRIGGER] > "Trigger Manager..."



Background information

Refer to [Chapter 5.1.4.1, "Partial Measurements and Driving Mode"](#), on page 73.

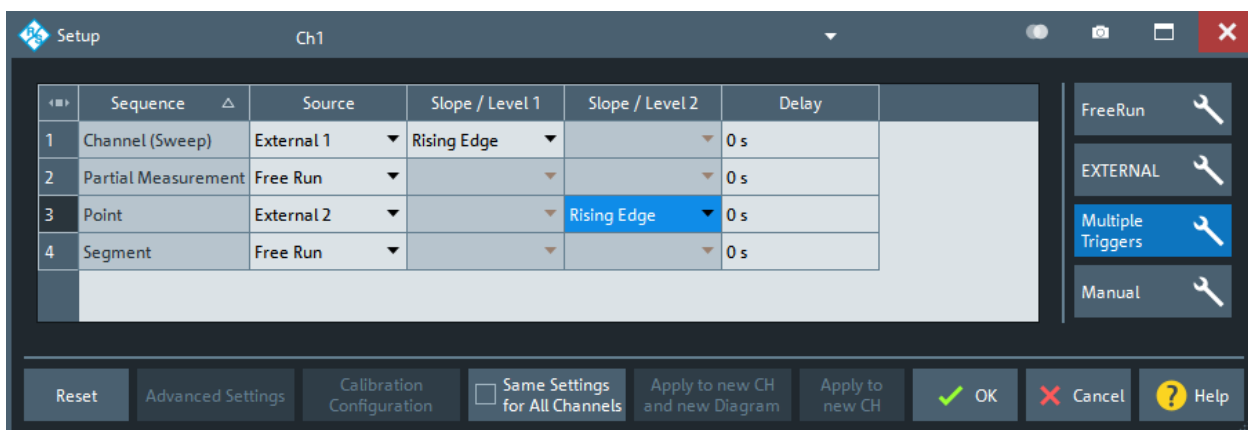

Figure 6-8: Example of a multiple trigger configuration

The table in the "Trigger Manager" dialog contains several editable (white) or non-editable (gray) columns. All settings are analogous to the general trigger settings in the [Trigger Tab](#). Refer to the following sections:

- ["Sequence"](#) on page 367
- ["FreeRun / External / Manual / Multiple Triggers"](#) on page 366
- ["Signal Type"](#) on page 368
- ["Delay"](#) on page 368

... /Source/ ...

The table defines all settings related to "Multiple Triggers" (see [Chapter 6.10.3, "Trigger Tab"](#), on page 365). For all measurement sequences the following trigger sources are available:

- "Free Run" means that a trigger signal is not required
- "External 1" is the external trigger signal fed in at either the EXT TRIG IN connector on the rear panel or pin 2 of the USER PORT connector.
- "External 2" is the external trigger signal fed in at pin 25 of the USER PORT connector on the rear panel.
- "External 1 and 2"/"External 1 or 2" means that the measurement sequence is initiated after the analyzer has received an event from external trigger signal 1 and/or 2. A [Signal Type](#) must be specified for both trigger signals.
- **Manual** means that the trigger event is generated manually, by selecting the [Manual Trigger](#) button.

For example, a new sweep can be triggered by an external trigger no. 1, while the individual sweep points are triggered by external trigger no. 2. External trigger 1 is ignored if a sweep is running, external trigger 2 is ignored if there is no running sweep. In the figure below a sweep comprises 5 measurement points and dotted arrows depict ignored trigger events.

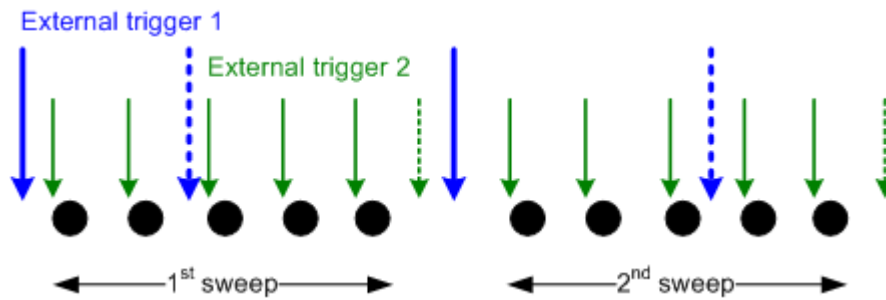

Remote command:

```
TRIGger<Ch>[:SEquence]:MULTiple:SOURce
TRIGger<Ch>[:SEquence]:MULTiple:SLOPe<Num>
TRIGger<Ch>[:SEquence]:MULTiple:HOLDoff
```

6.10.4 Sweep Control Tab

Allows you to control the sweep execution.



The availability of certain settings depends on the selected [Remote Language](#).

6.10.4.1 Controls on the Sweep Control Tab

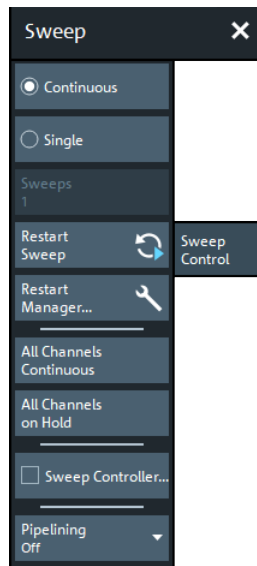

Continuous / Single

Activate either continuous (default) or single sweep mode.

- In "Continuous" sweep mode, the analyzer measures the related channel (or channels) continuously, repeating the current sweep over and over.
- In "Single" sweep mode, the measurement is stopped after the configured number of [Sweeps](#).

Restart Sweep initiates a new measurement cycle.

For the DEFAULT **Remote Language**, this setting applies to the active channel only. Use **All Channels Continuous/All Channels on Hold** to select a common sweep mode for all channels.

For remote languages other than DEFAULT, this setting applies to all channels.

Remote command:

```
INITiate<Ch>:CONTInuous
```

See also:

```
CONFigure:CHANnel<Ch>:MEASure[:STATe]
```

```
CONFigure:CHANnel:MEASure:ALL[:STATe]
```

Sweeps

Defines the number of sweeps to be performed in "Single" sweep mode (see "**Continuous / Single**" on page 370).

This setting applies to the active channel. In "Continuous" sweep mode, it is not available (grayed out).

For **remote languages** other than DEFAULT, the "Sweeps" setting is disabled. You can define the number of sweeps in the **Restart Manager Dialog**.

Remote command:

```
[SENSe<Ch>:]SWEep:COUNT
```

```
[SENSe:]SWEep:COUNT:ALL
```

Restart Sweep

Stops the current measurement cycle and starts a new one.

For the DEFAULT **Remote Language**, the effect of this command depends on the **sweep modes** of the active channel, and the restart behavior defined in the **Restart Manager Dialog**:

	"Sweep Active Channel"	"Sweep All Channels"
Active channel in "Continuous" sweep mode	The "Continuous" sweep mode channels are swept cyclically, the "Single" sweep channels are on hold.	First the "Single" sweep mode channels are swept one after the other, each with its channel-specific number of "Sweeps". Then the "Continuous" sweep mode channels are sweep cyclically.
Active channel in "Single" sweep mode	First the active channel is swept with its channel-specific number of "Sweeps". Then the "Continuous" sweep mode channels are sweep cyclically.	

For remote languages other than DEFAULT, the effect of the "Restart Sweep" command is determined by the selected (common) sweep mode and restart behavior:

	"Sweep Active Channel"	"Sweep All Channels"
All channels in "Continuous" sweep mode	The channels are swept cyclically	
All channels in "Single" sweep mode	The active channel is swept "Sweeps" times. All other channels are on hold	The channels are swept one after the other, each of them "Sweeps" times.

Remote command:

```
INITiate<Ch>[:IMMediate] [:DUMMy]
INITiate[:IMMediate]:ALL
```

Restart Manager...

Opens the [Restart Manager Dialog](#).

All Channels Continuous/All Channels on Hold

Selects a common [sweep mode](#) for all channels of the active recall set.

- "All Channels Continuous": all channels are set to "Continuous" sweep mode
- "All Channels on Hold": all channels are set to "Single" sweep mode.

[Restart Sweep](#) initiates a new measurement cycle.

These actions are only available for the DEFAULT [Remote Language](#)). For other remote languages, the [Continuous / Single](#) setting applies to all channels and the "All Channels Continuous"/"All Channels on Hold" buttons are greyed out;

Remote command:

```
INITiate:CONTInuous:ALL
```

Sweep Controller

Activates/deactivates the (resizable) "Sweep Info" dialog, which displays the current sweep stage. The "Sweep Info" dialog is particularly useful for long duration sweeps that are executed in single sweep mode: by observing the dialog, it is easy to realize when the sweep is done.

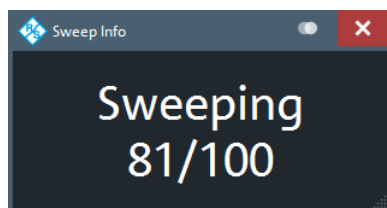

The possible sweep stages and how they are displayed partly depend on the selected sweep mode (see "[Continuous / Single](#)" on page 370):

Sweep stage	Sweep controller display	
	in "Continuous" sweep mode	in "Single" sweep mode
No ongoing sweep	<i>Idle</i>	<i>Idle</i>
Sweep is being prepared	<i>Preparing</i>	<i>Preparing</i>
Ongoing sweep ¹⁾	<i>Continuous</i>	<i>Sweeping</i> if #Sweeps = 1
		<i>Sweeping m/n</i> if n = #Sweeps > 1
Measurement results are being calculated	<i>Continuous calculation</i>	<i>Calculation</i>
¹⁾ The VNA is sweeping or waits for a trigger signal.		

Pipelining

Allows you to activate pipelining of measurement data for alternated [Driving Mode](#). See [Chapter 5.1.4.2, "Pipelining of Measurement Data"](#), on page 74.

Remote command:

```
INITiate:PIPeLineing:STATe
(CALCulate:PIPeLineing:DATA?)
```

6.10.4.2 Restart Manager Dialog

The "Restart Manager" dialog defines the [Restart Sweep](#) behavior in "Single" sweep mode.

Access: CHANNEL – [SWEEP] > "Sweep Control" > "Restart Manager..."



Related information

Refer to [Chapter 5.1.4, "Sweep Control"](#), on page 72.

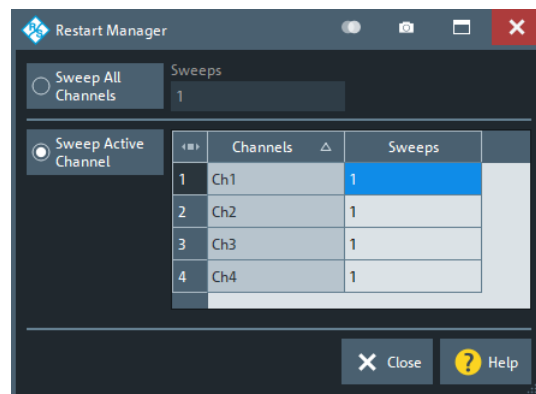

Sweep All Channels/Sweeps

If you select "Sweep All Channels", [Restart Sweep](#) restarts the sweep in all channels of the active recall set.

For the DEFAULT [Remote Language](#), the number of sweeps in single sweep mode is channel-specific and can be defined in the table below the separator line. The "Sweeps" column reflects the [Sweeps](#) settings of the individual channels. The "Sweeps" setting above the separator line is unused and disabled.

For remote languages other than DEFAULT, the "Sweeps" setting above the separator line defines the common number of sweeps that are executed on each channel in single sweep mode. The table below the separator line is unused and disabled.

Tip: In remote control, it is possible to retrieve the results acquired in any of the sweeps within a single sweep group.

Remote command:

```
INITiate[:IMMediate]:ALL
INITiate<Ch>[:IMMediate]:SCOPE ALL
[SENSe<Ch>:]SWEep:COUNT
```

Sweep Active Channel/Sweeps (table)

If you select "Sweep Active Channel", then in single sweep mode [Restart Sweep](#) only restarts the sweep in the active channel.

The "Sweeps" column reflects the [Sweeps](#) settings of the individual channels.

Remote command:

```
INITiate<Ch>[:IMMediate]:SCOPE SINGLE
[SENSe<Ch>:]SWEep:COUNT
```

6.11 Cal Softtool

The "Cal" softtool provides all functions related to system error calibration and scalar power calibration.

Access: CHANNEL – [CAL]

6.11.1 Start Cal Tab

The "Start Cal" tab provides access to all functions for automatic or manual calibration. Calibration of the R&S ZND is a fully guided process.



Background information

Refer to the following sections:

- [Chapter 5.5, "Calibration"](#), on page 140
- [Chapter 5.5.5, "Automatic Calibration"](#), on page 159
- [Chapter 5.5.6, "Scalar Power Calibration"](#), on page 167
- [Chapter 5.1.5, "Data Flow"](#), on page 77

6.11.1.1 Controls on the Start Cal Tab

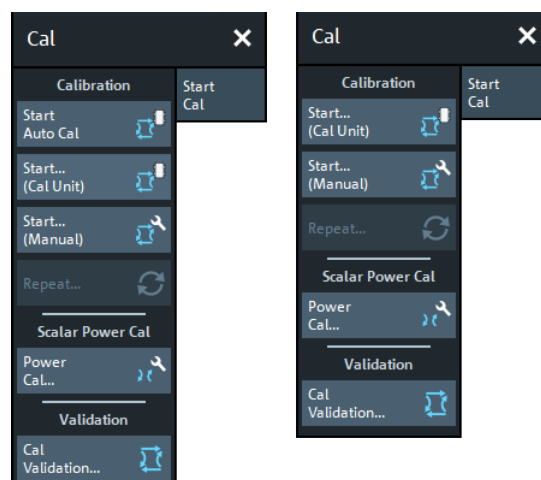

left = bidirectional R&S ZND
right = unidirectional R&S ZND



- The "Start Auto Cal" and "Start... (Cal Unit)" buttons are only active if a calibration unit is connected to the analyzer.
For a unidirectional R&S ZND, "Start Auto Cal" is not supported and hence this button is hidden.
- If there is more than one channel in the current recall set at the time you initiate a calibration, the [Channel Selection for Calibration Dialog](#) is opened.

Start Auto Cal

Performs a fully automatic system error calibration for the active channel, using the active calibration unit with its factory calibration and auto-detection of ports.

If one port is active, an OSM calibration is performed. If two ports are active, an UOSM calibration is performed.

For a unidirectional R&S ZND, auto-detection of ports is not possible and hence this button is hidden.

Calibration – Start... (Cal Unit)

Opens the [Calibration Unit Wizard](#).

Calibration – Start... (Manual)

Opens the [Calibration Setting Wizard](#).

Calibration – Repeat...

Re-enters the data acquisition step of the current calibration, restoring the related channel settings. This provides a convenient way to repeat or correct an existing calibration without necessarily repeating all measurements.

Scalar Power Cal – Power Cal...

Opens the [Power Cal Wizard](#).

If the active recall set contains several channels, an "Info" box lets you decide whether the R&S ZND acquires calibration data for the active channel or for all channels.

Cal Validation ...

Opens the [Cal Validation Dock Widget](#) that allows you to set up and run a [Calibration Validation](#).

6.11.1.2 Channel Selection for Calibration Dialog

If you initiate a calibration and there is more than one channel in the current recall set, you are prompted to select the channels to be calibrated:

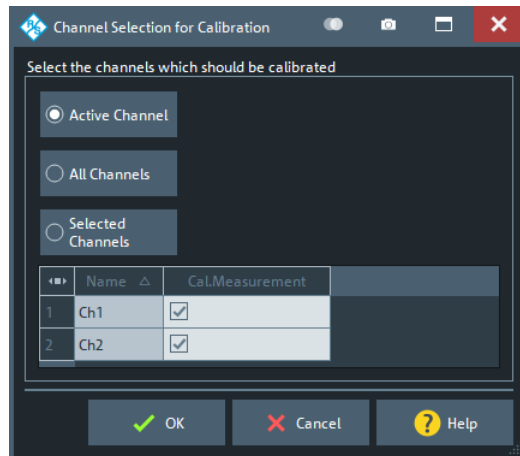

Use

- "Active Channel" if you only want to calibrate the active channel
- "All Channels" if you want to calibrate all channels in the current recall set
- "Selected Channels" if you want to calibrate only certain channels

6.11.1.3 Calibration Unit Wizard

The "Calibration Unit" wizard guides you through the setup and execution of an automatic calibration.

Access: CHANNEL – [CAL] > "Start Cal" > Calibration – "Start... (Cal Unit)"

The wizard proceeds in three steps.

1. [Step 1: Ports](#) allows you to configure the calibration and to select a calibration unit (along with its characterization).
2. [Step 2: Connections](#) allows you to define the port assignments between the R&S ZND and the calibration unit.
3. [Step 3: Cal Unit](#) guides you through the required measurements on the standards provided by the calibration unit. Finally, you can either apply the resulting error terms to the related channels, or discard them.



Background information

Refer to [Chapter 5.5.5, "Automatic Calibration"](#), on page 159.



- A successful calibration supersedes the previous calibration, discarding all previous system error correction data.
To keep older correction data, you can transfer them to the calibration "Pool" using the [Calibration Manager Dialog](#).
- The system error correction data that are determined in a calibration procedure, are stored in the analyzer. It is possible to retrieve these data using the remote control command `[SENSe<Ch>:]CORRection:CDATa`.
If external switch matrices are involved, use `[SENSe<Ch>:]CORRection:SMATrix:CDATa` instead.

Step 1: Ports

Allows you to define the calibration to be performed and to select the calibration unit to be used (along with its characterization).



Background and related information

Refer to the following sections:

- [Chapter 5.5.1, "Calibration Types"](#), on page 141
- [Chapter 5.5.5.3, "Characterization of Calibration Units"](#), on page 162

The layout of the main panel depends on the number of test ports available:



Figure 6-9: Calibration Unit wizard, step 1: Ports



Figure 6-10: Calibration Unit wizard, step 1: Ports (> 4 test ports)

Ports

Selects the test ports to be calibrated.

Note: Calibration and port de-/activation.

The analyzer firmware automatically activates/deactivates ports during/after a (successful) calibration:

- Calibrated ports that were previously disabled, are automatically enabled as single-ended logical ports.
- An uncalibrated port that is not used by a measurement (i.e. the port is not required by any trace of the related channel) is disabled.

Remote command:

The port parameters in many calibration commands define the calibrated ports.

Cal Unit

Displays the connected calibration units. The R&S ZND auto-detects all calibration units which are connected to one of its USB ports. If several cal units are connected, one of them must be selected for calibration (active cal unit). A warning is displayed if the current sweep range of the network analyzer exceeds the characterized frequency range of the calibration unit.

For background information, see [Chapter 5.5.5, "Automatic Calibration"](#), on page 159.

Remote command:

```
SYSTem:COMMunicate:RDEvice:AKAL:ADDRESS:ALL?
SYSTem:COMMunicate:RDEvice:AKAL:ADDRESS
```

Characterization

Displays all characterizations that are stored in the active cal unit. The "Factory" characterization is available for all calibration units; it ensures an accurate calibration for all standard applications. To account for modifications of the cal unit such as the connection of additional adapters, you can generate modified sets of characterization data using the cal unit characterization wizard. See [Chapter 6.11.2.3, "Characterize Cal Unit Dialog"](#), on page 409. By default, the R&S ZND uses the last generated cal unit characterization.

Tip: If the characterization wizard is password-protected, the "Characterization" button is unavailable. Use this functionality to prevent inadvertent activation of inappropriate characterizations. See ["Authentication"](#) on page 410.

See also [Chapter 5.5.5.3, "Characterization of Calibration Units"](#), on page 162.

Remote command:

```
SYSTem:COMMunicate:RDEvice:AKAL:CKIT:CATalog?
SYSTem:COMMunicate:RDEvice:AKAL:CKIT:STANdard:CATalog?
SYSTem:COMMunicate:RDEvice:AKAL:SDATa?
```

Query further cal unit properties:

```
SYSTem:COMMunicate:RDEvice:AKAL:DATE?
SYSTem:COMMunicate:RDEvice:AKAL:FRANge?
SYSTem:COMMunicate:RDEvice:AKAL:PORTs?
SYSTem:COMMunicate:RDEvice:AKAL:WARMup[:STATe]?
```

Calibration Type / Source

Selects the calibration type for the selected physical ports. For an overview, refer to [Table 5-7](#).

The reflection calibration types can be used for any combination of physical ports: reflection calibrations are performed for each selected port.

A transmission calibration type requires at least two physical ports. For the **unidirectional** transmission calibration types ("Trans Norm", "One Path Two Ports"), the direction ("**Source**" port) must be specified in addition.

Note: For a unidirectional R&S ZND, the bidirectional transmission calibration types "Trans Norm Both", TOSM and UOSM are not available

Transmission normalization and "One Path Two Ports" calibration types require two-port (Through) characterization data for the cal unit. For current calibration units, however, these two-port characterizations are typically not part of the factory characterization. If a tooltip indicates missing two-port characterization data, simply perform a new characterization of your cal unit. In the first dialog of the "Characterization" wizard, select "Take All OSM and Through" to make sure that the necessary two-port data is acquired. See also ["Characterization Wizard"](#) on page 411.

Note: For a unidirectional R&S ZND, Through data can't be created using the characterization wizard. Use a more powerful Rohde & Schwarz VNA to create two-port characterizations.

Remote command:

```
[SENSe<Ch>:]CORRection:COLLect:AUTO:TYPE
[SENSe<Ch>:]CORRection:COLLect:AUTO:PORTs:TYPE
```

Common Port

This combo-box is only available if [Use Reduced Number of Through](#) is activated in the "Calibration" tab of the "System Config" dialog.

It defines the port that must appear in each port assignment of an automatic calibration, and that will be used as the "center" of all Through measurements.

Remote command:

```
[SENSe<Ch>:]CORRection:COLLect:AUTO:CPORT
```

Select All/Deselect All

Selects/deselects all ports.

These buttons are only shown if more than 4 ports are available.

Next

Proceeds to [Step 2: Connections](#). "Next" is unavailable (and a warning is displayed) if the following happens:

- The selected characterization data do not cover all the ports to be calibrated.
- The selected characterization data do not contain all standards needed for the selected calibration type.

Step 2: Connections

Defines the port assignments between the R&S ZND and the calibration unit.

**Background information**

Refer to [Chapter 5.5.5.5, "Multiple Port Assignments"](#), on page 165 for details on multiple port assignments

Depending on the number of test ports, the user interface is slightly different:

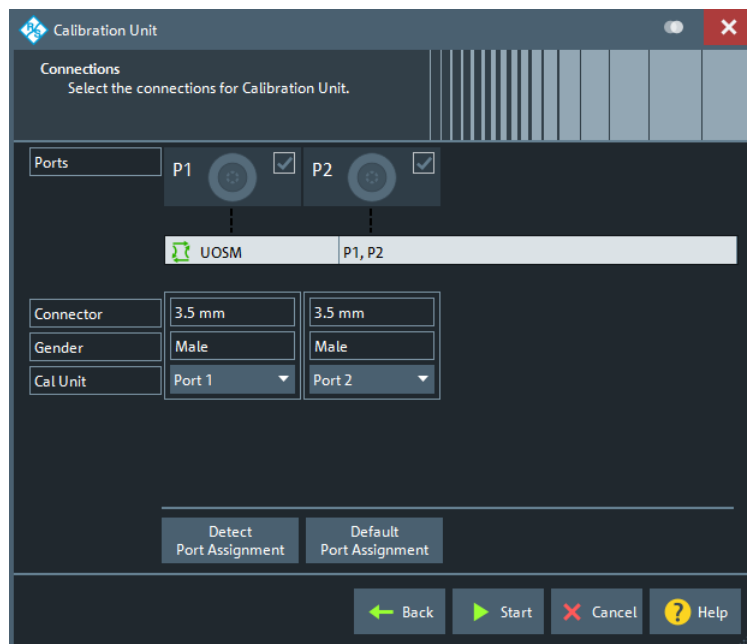

Figure 6-11: Calibration Unit wizard, step 2: Connections

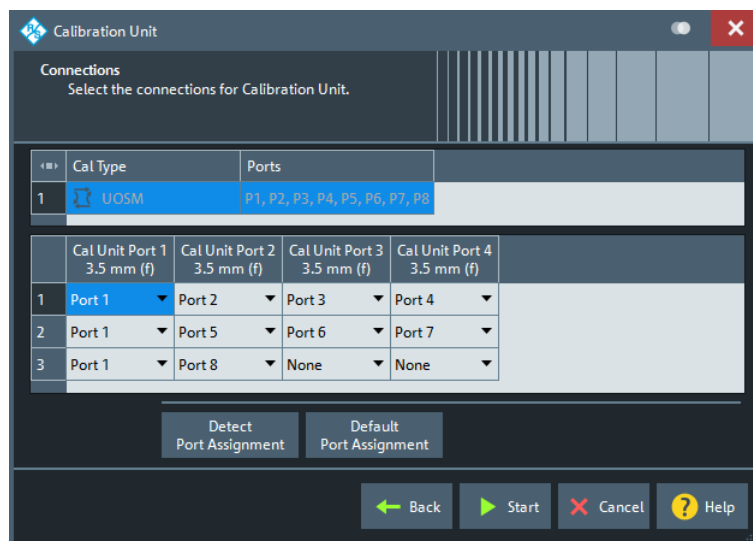

Figure 6-12: Calibration Unit wizard, step 2: Connections (>4 test ports and multiple port assignments)

If multiple port assignments are required and ["Use Reduced Number of Through"](#) on page 521 is enabled, make sure that each port assignment contains the [Common Port](#).

Port Assignment (manual)

The "Connections" step allows you to configure the assignment between VNA ports and calibration unit ports manually.

The test port connectors are automatically set according to the connector type of the selected calibration unit port.

Detect Port Assignment

Starts a procedure by which the R&S ZND (with a little help from the attached calibration unit) auto-detects the connected ports. The automatic assignment replaces the configured one.

If auto-detection fails because of a high attenuation in the signal path, you can either enter the port assignment manually or connect matching port numbers and select "Default Port Assignment".

Note: For a unidirectional R&S ZND (see [Chapter 5.1.4.3, "R&S ZND: Unidirectional vs. Bidirectional Operation"](#), on page 75) auto-detection at VNA port 2 does not work.

Remote command:

```
[SENSe:]CORRection:COLLect:AUTO:PORTs:CONNECTION?
```

Default Port Assignment

Restores the default port assignment.

Start

Proceeds to [Step 3: Cal Unit](#).

If the configured port assignments are invalid, this action is disabled.

Step 3: Cal Unit

During the calibration phase, the R&S ZND displays a "Cal Unit" screen that guides the user through the actual correction data acquisition.

In each calibration step

- the calibration unit must be connected according to the depicted port assignment; auto-detection is possible
- the related test ports are calibrated with the "Calibration Type" selected in [Step 1: Ports](#)
- a subsweep is performed for each required test port or port pair and every required standard (and for every possible path between the port pairs, if external switch matrices are involved)

After all these calibration steps have been completed, the resulting system error correction can be calculated and applied.



In the upper part of the "Cal Unit" screen, the R&S ZND shows the calibration sweep diagrams for the currently measured S-parameter. The lower part visualizes the active port assignment and the measurement progress.

Calibration Sweep Diagrams

During the calibration sweep, each diagram contains a single S-parameter trace and a typical result trace for the measured calibration standard.

If switch matrices are involved, a sweep is performed for every possible signal path and for each of these paths a separate S-parameter trace is shown (see [Chapter 5.7.20.5, "Multiple Paths and Calibration"](#), on page 215).

The purpose of the typical result traces "Trc1" and "Trc2" is to avoid connection errors and to track hardware problems: if the correct standard type is measured, and everything is properly connected, then the measured traces are expected to be similar to the typical trace.

The S-Parameter traces are labeled $P[j_i]_{\text{standard type}} S_{ij}$, where j indicates the input (test) port and i indicates the output port, e.g. $P[1_2]_{\text{Unknown_Through}} S_{21}$.

If switch matrices are involved, the label also indicates:

- which VNA port b is switched to the input port j and
- which VNA port a is switched to the output port i

Instead of a single S_{ij} trace we have multiple traces $S_{ijvat/vbtj}$. E.g., "S21v1t1v2t2" means that S21 is measured with VNA port 1 connected to the input port and VNA port 2 connected to the output port.

Start Cal Sweep / Abort Sweep

Starts the calibration sweep for the related port assignment or aborts it.

Remote command:

```
[SENSe<Ch>:]CORRection:COLLect:AUTO:ASSignment<Asg>:ACQuire
```

Detect Ports & Start Cal

Performs the "Detect Port Assignment" and "Start Cal Sweep" functions, one after the other.

Note: For a unidirectional R&S ZND (see [Chapter 5.1.4.3, "R&S ZND: Unidirectional vs. Bidirectional Operation"](#), on page 75) auto-detection at VNA port 2 does not work.

Detect Port Assignment

Starts a procedure by which the R&S ZND (with a little help from the attached calibration unit) auto-detects the connected ports. The automatic assignment replaces the configured one.

In case auto-detection fails

- an error report is shown as a warning dialog
- the undetected port connections are marked with warning signs
- the calibration can be invalid

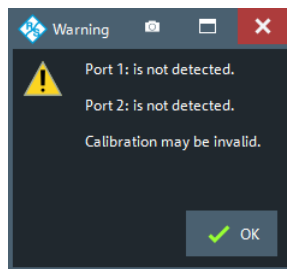

Note: For a unidirectional R&S ZND (see [Chapter 5.1.4.3, "R&S ZND: Unidirectional vs. Bidirectional Operation"](#), on page 75) auto-detection at VNA port 2 does not work.

Remote command:

```
[SENSe:]CORRection:COLLect:AUTO:PORTs:CONNection?
```

Prev/Next

Navigates between the port assignments. Only available if multiple port assignments are required.

Apply/Cancel

Apply the calculated system error correction to the active channel (or to all channels in the active recall set, if all channels were calibrated).

The Apply button is enabled when calibration sweeps have been successfully performed for all required port assignments.

Remote command:

```
[SENSe<Ch>:]CORRection:COLLect:AUTO
[SENSe<Ch>:]CORRection:COLLect:AUTO:PORTs
[SENSe<Ch>:]CORRection:COLLect:AUTO:PORTs:TYPE
[SENSe<Ch>:]CORRection:COLLect:AUTO:TYPE
[SENSe<Ch>:]CORRection:COLLect:AUTO:SAVE
```

Extended cal unit settings:

`MMEMory:AKAL:FACTory:CONVersion`

`MMEMory:AKAL:USER:CONVersion`

`SYSTem:COMMUnicate:AKAL:CONNectioN`

`SYSTem:COMMUnicate:AKAL:MMEMory[:STATe]`

6.11.1.4 Calibration Setting Wizard

The "Calibration Setting" wizard guides you through the setup and execution of a manual system error correction.

Access: CHANNEL – [CAL] > "Start Cal" > Calibration – "Start... (Manual)"

The wizard proceeds through the following steps:

1. **"Ports and Type"**: Select the ports you want to calibrate and the calibration type you want to use.
2. **"Connectors and Cal Kits"**: For all ports you want to calibrate, select the connector type, gender and cal kit. If necessary, import a calibration kit.
3. **"Calibration"**: Acquire measurement data for the required ports or port pairs and the required standards. Finally, decide whether to apply the resulting system error correction or to discard it.



Background and related information

- Refer to [Chapter 5.5, "Calibration"](#), on page 140 for background information
- If the active channel is already equipped with a system error correction, the "Calibration Setting" wizard loads the underlying setup. If the calibration setup is not changed and sweep data are available from previous calibrations, the existing system error correction can be optimized without repeating the measurement of all standards.
- When you apply the new system error correction, the current calibration is replaced and discarded.
To persist the current calibration, you can transfer it to the calibration "Pool" using the [Calibration Manager Dialog](#).
- The active system error correction data can be read (and modified) using the remote control command `[SENSe<Ch>:]CORRection:CDATa`.

Step 1: Ports and Type

Allows you to select the test ports to be calibrated and the calibration type to be used.



Background information

Refer to [Chapter 5.5.1, "Calibration Types"](#), on page 141.

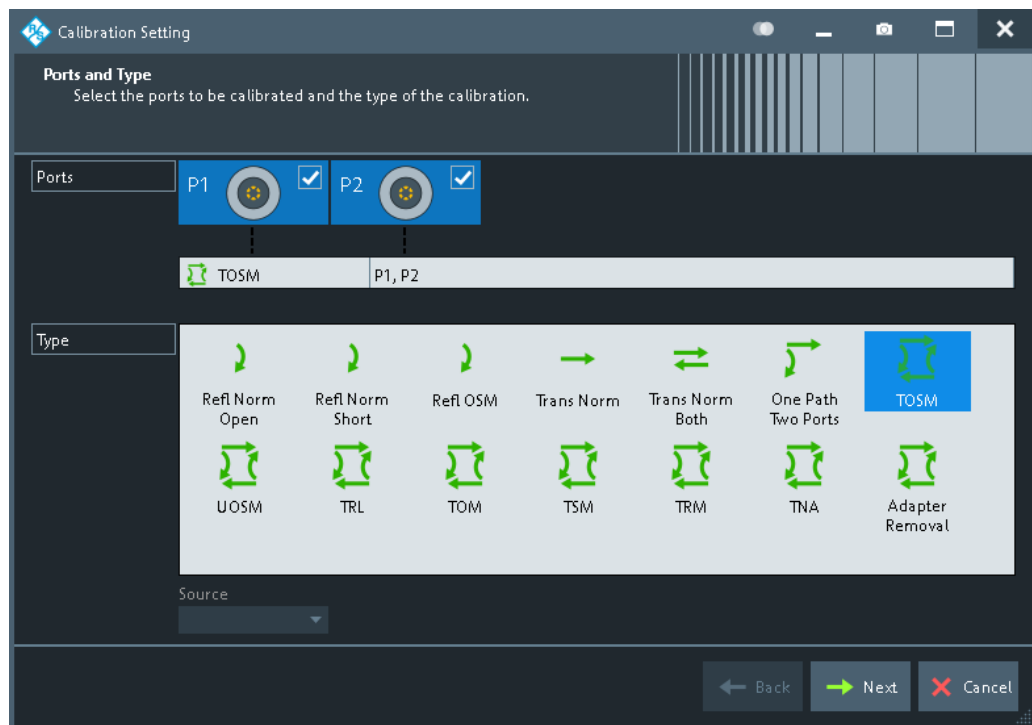

For a unidirectional R&S ZND (see [Chapter 5.1.4.3, "R&S ZND: Unidirectional vs. Bidirectional Operation"](#), on page 75), only port 1 can operate as source port. Hence the "Source" selector is disabled and bidirectional calibrations such as Trans Norm Both, TOSM, UOSM are not available.

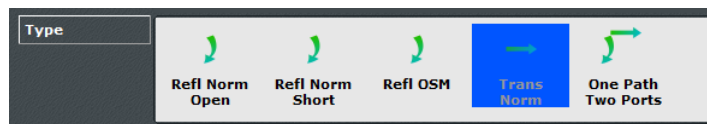

Ports

Selects the test ports to be calibrated.

Note: Calibration and port de-/activation.

The analyzer firmware automatically activates/deactivates ports during/after a (successful) calibration:

- Calibrated ports that were previously disabled, are automatically enabled as single-ended logical ports.
- An uncalibrated port that is not used by a measurement (i.e. the port is not required by any trace of the related channel) is disabled.

Remote command:

The port parameters in many calibration commands define the calibrated ports.

Type/Source

Selects the calibration type. The green arrow symbols give a preview of the type and the number of calibration sweeps involved:

- Curved arrows (example: "Refl Norm Open") denote one or more reflection measurements at each port.
Reflection calibration types can be used for any set of test ports: reflection calibrations are repeated for each port.
- Straight, horizontal arrows (example: "Trans Norm") denote one or more transmission measurements between each pair of two ports.
Transmission calibration types require at least two physical ports. For unidirectional transmission calibration types ("Trans Norm", "One Path Two Ports"), the ("**Source**" port) must be specified in addition.
- The full n-port calibration types ($n > 1$, e.g. "TOSM") are symbolized by a closed square symbol. The number of arrows increases the complexity but can also improve the accuracy of the calibration.

For an overview, refer to [Table 5-7](#).

Remote command:

```
[SENSe<Ch>:]CORRection:COLLect:METHod:DEFine
```

Calibrate all Channels

Check this box to apply the acquired correction data to all channels in the active recall set. Leave it unchecked (preset setting) to apply them only to the active channel.

Note that this option is available only if the active recall set contains multiple channels.

Remote command:

```
[SENSe:]CORRection:COLLect:CHANnels:ALL
```

Next

Proceeds to [Step 2: Connectors and Cal Kits](#).

Step 2: Connectors and Cal Kits

Selects the connector type and gender for all ports and allows you to import a calibration kit.

**Background information**

Refer to [Chapter 5.5.2, "Calibration Standards and Calibration Kits"](#), on page 152.



Messages in the dialog

An information message (or error message) is displayed if one of the following happens:

- One of the selected calibration kits is described by ideal kit parameters or typical values.
- One of the selected calibration kits does not contain all standards that are required for the previously selected calibration type.
- Different connector types are defined at the ports but the selected calibration type requires uniform connectors.
- A cal kit standard does not cover the entire calibrated frequency range.

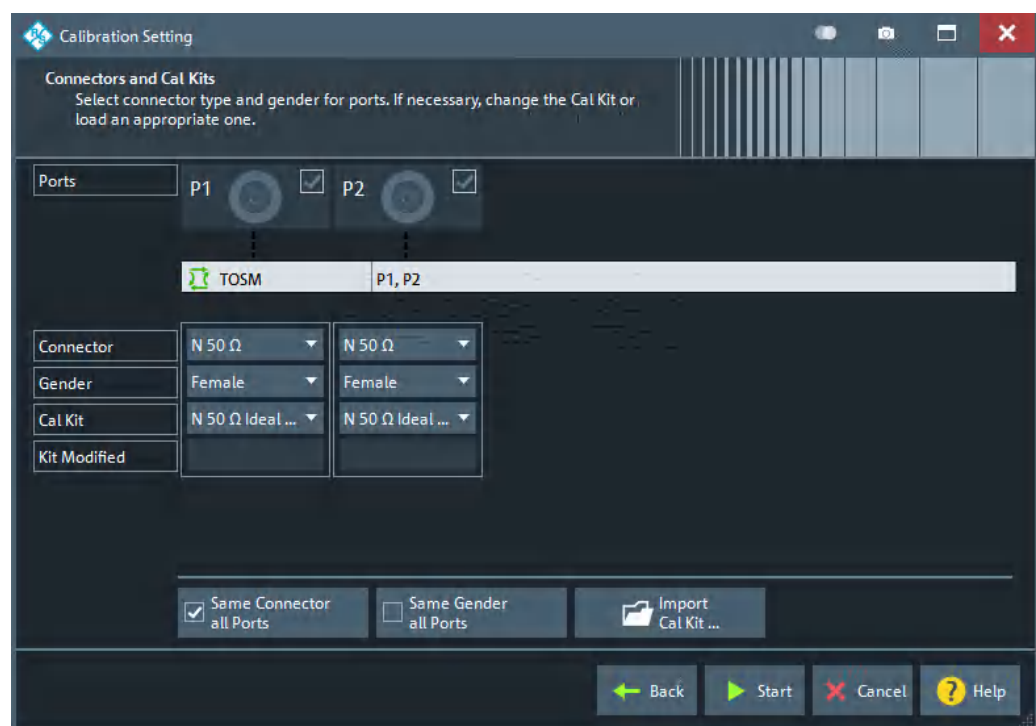

Figure 6-13: Calibration Setting Wizard, Step 2: Connectors and Cal Kits

The upper part of the panel shows the ports and the calibration type selected in [Step 1: Ports and Type](#). The lower part gives access to the connector and cal kit settings.

Connector / Gender

Defines the connector types and genders of the ports to be calibrated. For symmetric (sexless) connector types (e.g. 7 mm / PC7), "Gender" is unavailable.

If "Same Connector All Ports" is active, the connector types at all ports (but not their gender) are always adjusted to the current selection. If "Same Gender All Ports" is active, the genders at all ports are always adjusted to the current selection.

User-defined connectors can be added or removed in the [Cal Connector Types Dialog](#).

Remote command:

```
[SENSe<Ch>:]CORRection:COLLect:CONNection<PhyPt>
[SENSe<Ch>:]CORRection:COLLect:SCONnection<PhyPt>
[SENSe<Ch>:]CORRection:CONNection
[SENSe<Ch>:]CORRection:CONNection:CATalog?
[SENSe<Ch>:]CORRection:CONNection:DElete
```

Cal Kit

Selects a cal kit for the connector at each selected physical port. The drop-down list contains all available calibration kits for the selected connector type.

The assignment of a calibration kit to a connector type must be the same for all physical ports: If a calibration kit is changed, the R&S ZND automatically assigns the new kit to all ports with the same connector type.

Use "Import Cal Kit..." to add new kits to the list.

Remote command:

```
[SENSe:]CORRection:CKIT:SElect
```

Same Connector All Ports / Same Gender All Ports

Assigns the same connector type or gender to all selected physical ports. For some multi-port calibration types, the port connector types must be equal, e.g. because they require a Through standard with known characteristics.

Remote command:

```
[SENSe<Ch>:]CORRection:COLLect:CONNection:PORTs
[SENSe<Ch>:]CORRection:COLLect:CONNection:GENDeRs
```

Import Cal Kit...

Opens the "Import Calibration Kit" dialog that allows you to import a cal kit file. For background information, see [Chapter 5.5.2.4, "Cal Kit Files"](#), on page 157.

Remote command:

```
MMEMoRy:LOAD:CKIT
```

Back

Go back to [Step 1: Ports and Type](#).

Start

Start [Step 3: Calibration](#).

Step 3: Calibration

Allows you to acquire error correction data for every required port (pair) and calibration standard, where "required" depends on the selected ports and calibration type. On "Apply", the R&S ZND calculates the system error correction (error terms) from the measurement data of the standards and applies the result to the active channel.



Figure 6-14: Calibration Setting Wizard, Step 3: Calibration

In the upper part of the "Calibration" screen, the R&S ZND shows the sweep diagrams for the currently measured S-parameter. The lower part displays the calibrated ports and standards and visualizes the measurement progress.



For a unidirectional R&S ZND (see [Chapter 5.1.4.3, "R&S ZND: Unidirectional vs. Bidirectional Operation"](#), on page 75) the TOSM calibration depicted above is not available.

Calibration Sweep Diagrams

During the calibration sweep, each diagram contains a single S-parameter trace and a typical result trace for the measured calibration standard.

If switch matrices are involved, a sweep is performed for every possible signal path and for each of these paths a separate S-parameter trace is shown (see [Chapter 5.7.20.5, "Multiple Paths and Calibration"](#), on page 215).

The purpose of the typical result traces "Trc1" and "Trc2" is to avoid connection errors and to track hardware problems: if the correct standard type is measured, and everything is properly connected, then the measured traces are expected to be similar to the typical trace.

The S-Parameter traces are labeled $P[j_i]_{\langle \text{standard type} \rangle} S_{ij}$, where j indicates the input (test) port and i indicates the output port, e.g. $P[1_2]_{\text{Unknown_Through}} S_{21}$.

If switch matrices are involved, the label also indicates:

- which VNA port b is switched to the input port j and
- which VNA port a is switched to the output port i

Instead of a single S_{ij} trace we have multiple traces $S_{ijvatvbtj}$. E.g., "S21v1t1v2t2" means that S_{21} is measured with VNA port 1 connected to the input port and VNA port 2 connected to the output port.

Start Cal Sweep

The dock widget below the diagrams shows the calibrated ports and standards and visualizes the measurement progress.

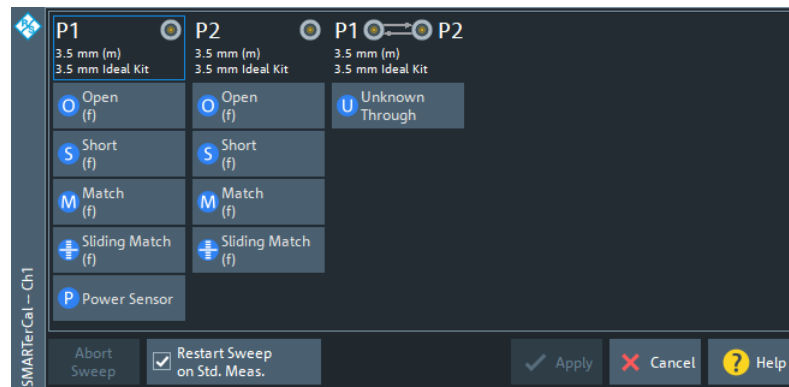

Use the buttons representing the calibration standards to start the corresponding calibration sweeps.

If "Show Cal Kit Label" is enabled on the [Calibration Tab](#) of the "System Config" dialog, an additional "Calibration Info" dialog is displayed. In this case, the cal sweep is started from this dialog.

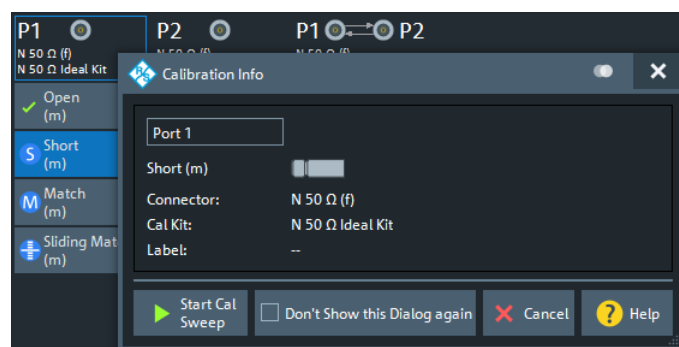

"Don't Show this Dialog Again" has the same effect as disabling "Show Cal Kit Label".

A green checkmark indicates that the calibration data of a standard has been acquired successfully. A green checkmark after the port symbol indicates that the minimum number of calibration measurements for the port has been performed.

Tip:

- For a TRL calibration, at least one line standard must be measured between any pair of calibrated ports. See [Chapter 5.5.1.9, "TRL Calibration"](#), on page 148.
- If the selected calibration kit comprises a Sliding Match, then for every required Match measurement either the Match or at least three positions of the Sliding Match must be measured. See [Chapter 5.5.2.3, "Sliding Match Standards"](#), on page 156.

Remote command:

```
[SENSe<Ch>:]CORRection:COLLect[:ACQuire]:SELected
```

See also: `[SENSe<Ch>:]CORRection:COLLect:LOAD:SELected`

Restart Sweep on Std. Meas.

If this function is active, a new standard measurement initiates a new sweep, starting at the beginning ("Start") of the sweep range: The sweep points for the calibration sweep are in ascending order, like for an ordinary measurement.

If "Restart Sweep on Std. Meas." is inactive, the new standard measurement is started at the current sweep point; the current sweep is continued as a calibration sweep.

Apply

Is enabled when sufficient data have been acquired for the calibrated ports and standards. The button starts the calculation of the system error correction and closes the calibration wizard. The current instrument settings are stored with the correction data.

To avoid incompatibilities, older calibration data is deleted unless it has been transferred into the calibration "Pool" using the "Calibration Manager" (see [Chapter 6.11.4.3, "Calibration Manager Dialog"](#), on page 423).

Note: Checks during the calculation of correction data

Incompatibilities between the selected calibration type, the standards and the channel settings can cause the calibration to be inaccurate. The analyzer auto-detects potential sources of errors and displays appropriate, self-explanatory notice boxes.

Remote command:

```
[SENSe<Ch>:]CORRection:COLLect:SAVE:SELected[:DUMMy]
```

```
[SENSe<Ch>:]CORRection:COLLect:SAVE:SELected:DEFault
```

```
[SENSe<Ch>:]CORRection:COLLect:DELeTe
```

```
[SENSe<Ch>:]CORRection:DATA:PARAmeter<Sfk>?
```

```
[SENSe<Ch>:]CORRection:DATE?
```

```
[SENSe<Chn>:]CORRection:SSTate?
```

```
[SENSe<Ch>:]CORRection:STIMulus?
```

6.11.1.5 Power Cal Wizard

The "Power Cal" wizard displays a single screen, showing the current source and receive ports. It allows you to perform "Ref. Receiver", "Meas. Receiver" and scalar source power ("Source Flatness") calibrations, based on the current power calibration settings (see [Chapter 6.11.3, "Pwr Cal Settings Tab"](#), on page 414).

Access: CHANNEL – [CAL] > "Start Cal" > "Power Cal..."

Screen Elements

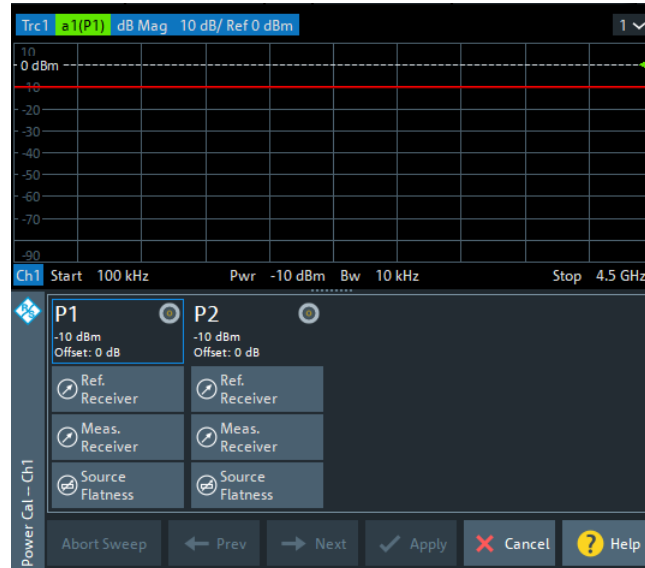

From top to bottom, the screen consists of the following elements.

Calibration Sweep Diagram

The calibration sweep diagram in the upper part of the screen shows the progress of the calibration and the accuracy of a completed calibration ("Verification"). The diagram is scaled in "dB Mag" format.

The diagram title indicates the ongoing calibration type and reading. The traces in the diagram vary according to the calibration stage.

While no calibration is performed, or during a source power calibration ("Power"), the following traces are displayed:

- A limit line (double horizontal) represents the target power of the source power calibration ("Cal Power").
- "Pmtr<n>" shows the reading of the power meter <n> in use. This trace is only shown during the first calibration sweeps; the following sweeps are based on the reference receiver result.
- "a<m>(P<m>)" shows the source power reading of the analyzer (wave quantity, reference receiver) at the calibrated source port P<m>.

After a successful power calibration, the trace "a<m>(P<m>)" must be close to the "Cal Power".

During a measurement receiver calibration ("Meas. Receiver"), the following traces are displayed:

- The trace "a<m>(P<m>)" shows the (previously calibrated) power at the calibrated reference plane (source port P<m>).
- The trace "b<n>(P<m>)" shows the current power reading of the analyzer at the calibrated receive port P<n> (source port P<m>).

After successful measurement receiver calibration, the " $b\langle n \rangle(P\langle m \rangle)$ " trace must be close to the " $a\langle m \rangle(P\langle m \rangle)$ " trace. Due to the previous power calibration, both traces must be close to the cal power.

Remote command:

```
SOURce<Ch>:POWer<PhyPt>:CORRection[:ACQuire]:VERification:
RESult?
```

Port Overview

Shows all source ports together with the possible power calibrations.

For each analyzer port P1 ... PN, a "Ref. Receiver", a "Meas. Receiver" and a "Source Flatness" calibration can be performed.

Note: For a unidirectional R&S ZND (see [Chapter 5.1.4.3, "R&S ZND: Unidirectional vs. Bidirectional Operation"](#), on page 75) P2 cannot serve as source port. Hence only a calibration of the measurement receiver can be performed at P2.

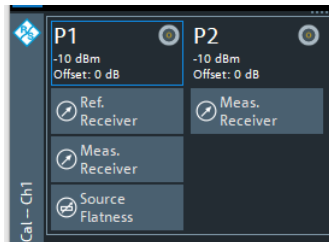

Select a "Ref. Receiver" or "Meas. Receiver" or "Source Flatness" symbol to start the related calibration. See "[Power Cal Dialog \(Ref. Receiver\)](#)" on page 395, and "[Power Cal Dialog \(Meas. Receiver\)](#)" on page 396, and "[Power Cal Dialog \(Source Flatness\)](#)" on page 397.

Select a "Power" or "Meas. Receiver" symbol to start the related calibration. See "[Power Cal Dialog \(Ref. Receiver\)](#)" on page 395, and "[Power Cal Dialog \(Meas. Receiver\)](#)" on page 396.

A green checkmark indicates that the calibration data has been acquired successfully.

Remote command:

```
SOURce<Ch>:POWer<PhyPt>:CORRection[:ACQuire]
[SENSe<Ch>:]CORRection:POWer<PhyPt>:ACQuire
SOURce<Ch>:POWer:CORRection:DATA:PARAmeter<Wv>?
SOURce<Ch>:POWer<PhyPt>:CORRection:DATA:PARAmeter<Wv>:COUNT?
```

Apply

Is enabled when a new set of power calibration data has been acquired for either a "Power" source or a "Meas. Receiver". The button applies all available source and/or measurement receiver calibrations to the active channel, aborts the verification sweeps, and closes the port overview section.

The power calibration state is indicated in the trace list, see [Chapter 5.5.6.3, "Power Calibration Labels"](#), on page 170. Use the functions in the [Chapter 6.11.4, "Use Cal Tab"](#), on page 421 to activate, deactivate, or store power calibrations.

Remote command:

```
SOURce<Ch>:POWer<PhyPt>:CORRection[:ACQuire]
[SENSe<Ch>:]CORRection:POWer<PhyPt>:ACQuire
```

```
SOURce<Ch>:POWER:CORRection:DATA
[SENSe<Chn>:]CORRection:PState?
```

Power Cal Dialog (Ref. Receiver)

In Ref. Receiver mode, the "Power Cal" dialog guides you through a reference receiver calibration.

The selected source port is displayed with its cal power settings (see [Chapter 6.11.3.2, "Modify Cal Power Dialog"](#), on page 416). A circuit diagram visualizes the connectivity. A power meter must be connected to the calibrated source port.

Access: [Power Cal Wizard](#) > Ref. Receiver



Background information

Refer to [Chapter 5.5.6.1, "Source Power Calibration"](#), on page 168.

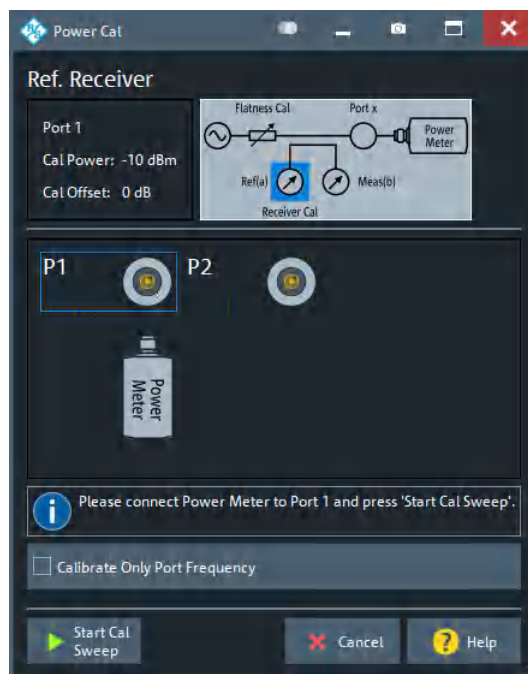

Start Cal Sweep

Starts the calibration sweeps for the selected port and power calibration settings and closes the dialog. The calibration is performed as described in ["Calibration procedure"](#) on page 168.

Open the [Pwr Cal Settings Tab](#) if you wish to modify the calibration procedure.

Remote command:

```
SOURce<Ch>:POWER<PhyPt>:CORRection[:ACquire]
SOURce<Ch>:POWER<PhyPt>:CORRection:COLLect[:ACquire]
```

Calibrate Only Port Frequency

Not relevant for the R&S ZND. This setting will be ignored.

Power Cal Dialog (Meas. Receiver)

In "Meas. Receiver" mode, the "Power Cal" dialog guides you through the calibration of a measurement receiver. To ensure accurate source signal powers, a source power calibration must be performed before the measurement receiver calibration.



Background information

Refer to [Chapter 5.5.6.2, "Measurement Receiver Calibration"](#), on page 169.

Access: [Power Cal Wizard](#) > "Meas. Receiver"

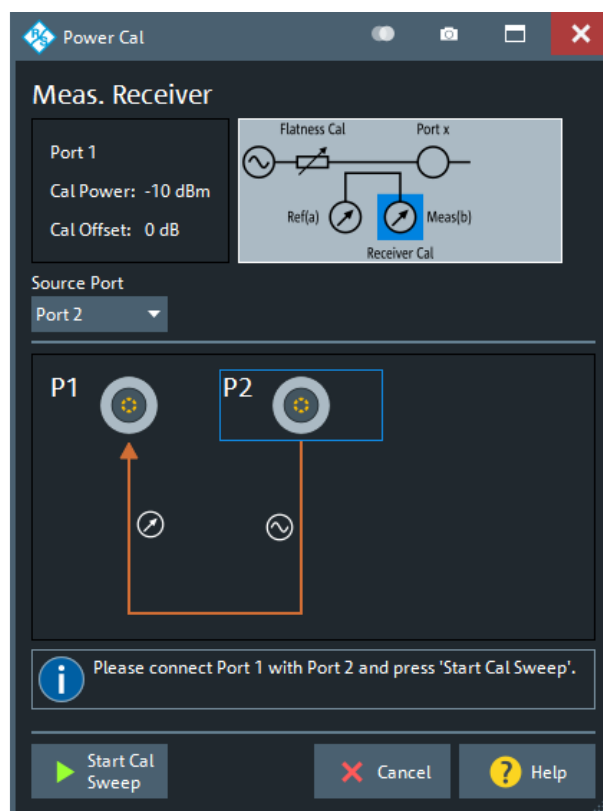
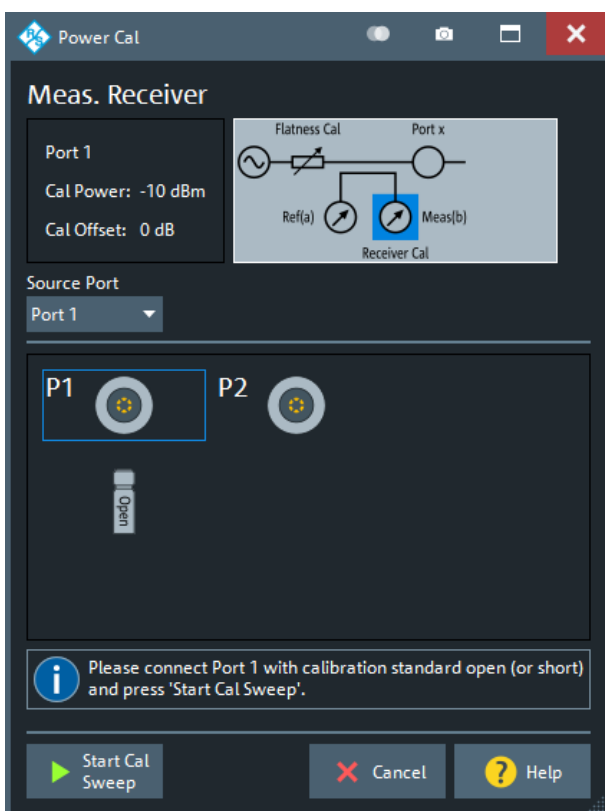

left: = source and meas. port identical
right = source and meas. port different

Port Overview

The dialog shows all receiver ports of the network analyzer. The selected port is displayed with the current cal power settings (see [Chapter 6.11.3.2, "Modify Cal Power Dialog"](#), on page 416); moreover, a circuit diagram visualizes the purpose of the measurement receiver calibration.

"Source Port" defines the type of measurement receiver calibration:

- If the source port is equal to the calibrated port, the measurement receiver is calibrated by the wave that is reflected back by a connected Open or Short standard. Connect the Open or Short standard to the calibrated port; no additional external test setup is required.

- If the source port and the calibrated port are different, the measurement receiver is calibrated by the wave generated at the source port. Connect the source port to the calibrated port, including any external devices that you used for the source power calibration.

For the source port, a source power calibration must be active.

Remote command:

```
[SENSe<Ch>:]CORRection:POWer<PhyPt>:ACQuire
```

Start Cal Sweep

Start the calibration sweep for the selected port and power calibration settings and close the dialog. The calibration is performed as described in ["Calibration procedure"](#) on page 170. No additional calibration settings are needed.

Remote command:

```
[SENSe<Ch>:]CORRection:POWer<PhyPt>:ACQuire
```

```
[SENSe<Ch>:]CORRection:POWer:DATA
```

Power Cal Dialog (Source Flatness)

In "Source Flatness" mode, the "Power Cal" dialog guides you through a source power calibration of a single port.

The dialog shows the selected source port with its current cal power settings (see [Chapter 6.11.3.2, "Modify Cal Power Dialog"](#), on page 416).

A circuit diagram visualizes the calibration setup, which depend on the selected [Pwr Cal Method](#).

- "Ref. Receiver": connect a DUT or a Match to the related source port
- "Power Meter": connect a power meter to the related source port

Access: [Power Cal Wizard](#) > "Source Flatness"



Background information

Refer to [Chapter 5.5.6.1, "Source Power Calibration"](#), on page 168.

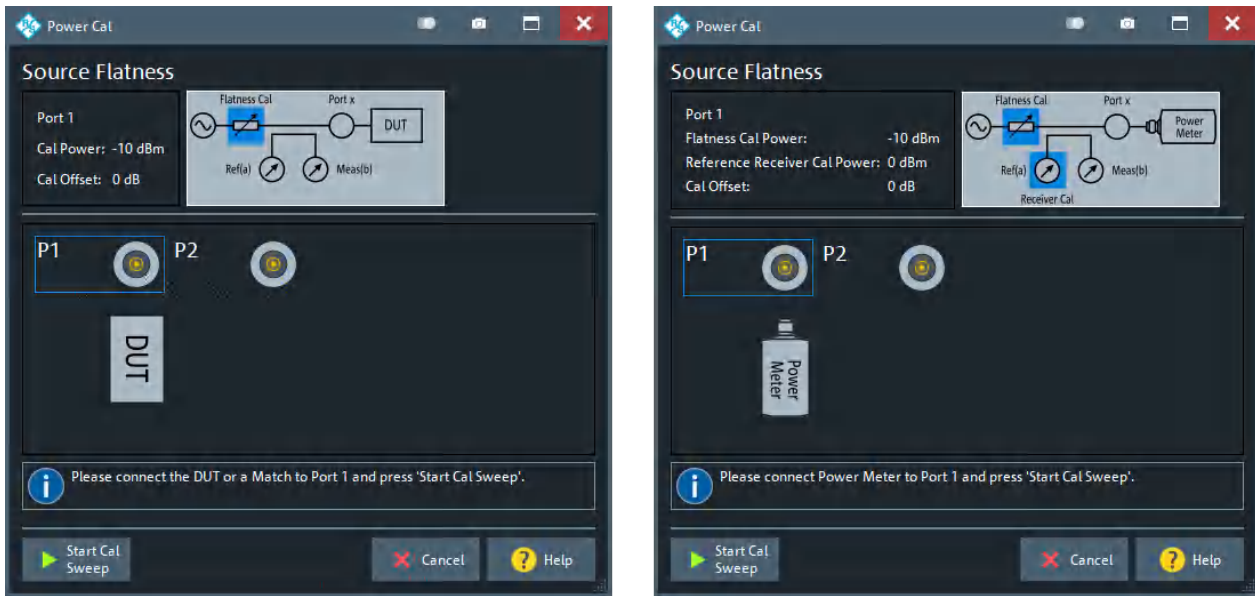

left = "Ref. Receiver" Pwr Cal Method
 right = "Power Meter" Pwr Cal Method

Start Cal Sweep

Start the calibration sweeps for the selected port and power calibration settings and close the dialog. The calibration is performed as described in ["Calibration procedure"](#) on page 168.

Use the [Pwr Cal Settings Tab](#) "Pwr Cal Settings" to modify the calibration procedure.

Remote command:

```
SOURce<Ch>:POWER<PhyPt>:CORRection[:ACQuire]
```

```
SOURce<Ch>:POWER<PhyPt>:CORRection:COLLect[:ACQuire]
```

6.11.1.6 Cal Validation Dock Widget

The controls on the "Cal Validation" dock widget allow you to set up and run a [Calibration Validation](#) in [basic](#) or [advanced](#) mode.

Basic Mode

In basic mode, the validation runs automatically, with autodetected ports and the settings specified in [Advanced Mode](#) (default settings after a system [PRESET]).

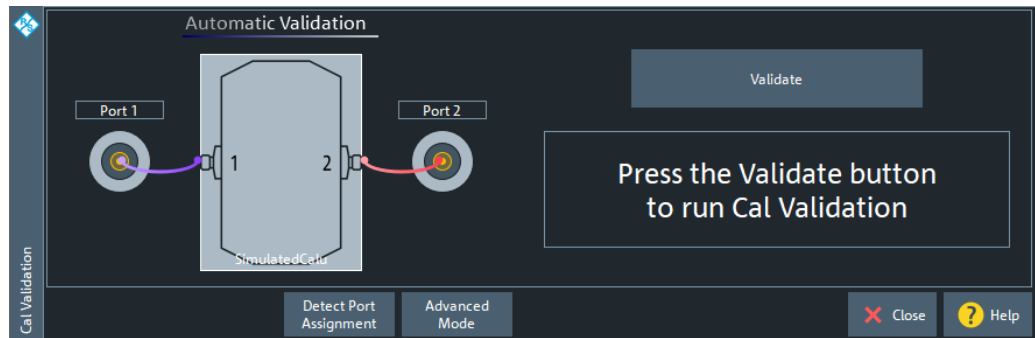

Use "Detect Port Assignment" to detect the current port assignment (after reconnecting the calibration unit).



Manual port assignment is not supported.

Validate

Runs the validation for the current port assignment. The validation proceeds through the connected ports $p \in \{1, \dots, 4\}$ in ascending order, measuring S_{pp} for the Open, Short and Match standard.

- "PASS": all measured reflection parameters are within the specified [Validation Limits](#), compared to the selected reference [characterization](#).
- "FAIL" otherwise.
[In this case, the validation stops at the first failed reflection measurement.]

Remote command:

`CALCulate:CALValidate:RUN`

Advanced Mode

Switches to [Advanced Mode](#).

Advanced Mode

In advanced mode you can configure the validation settings ([Characterization](#), [Validation Limits](#)) and run or rerun particular measurements ([Measurement](#), ["Calibration Standard"](#) on page 400).

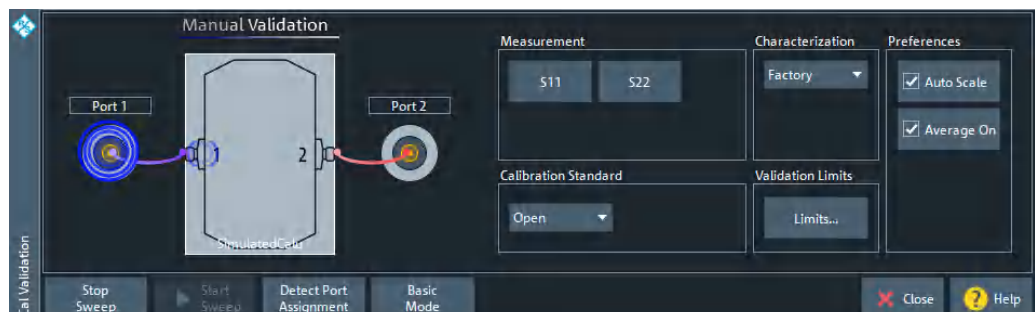

Use "Detect Port Assignment" to detect the current port assignment (after reconnecting the calibration unit).

Measurement

Selects the measurement to be performed in advanced mode and runs it

Characterization

Selects the calibration unit characterization to be used for the validation.

By default the factory characterization is used.

Remote command:

`CALCulate:CALValidate:CHARacteriza`

Calibration Standard

Selects the calibration standard to be measured in advanced mode.

Validation Limits

The "Limits..." button opens the "Cal Validation Limits" dialog that allows you to specify the maximum tolerable deviations from the corresponding S-parameters of the selected reference [characterization](#).

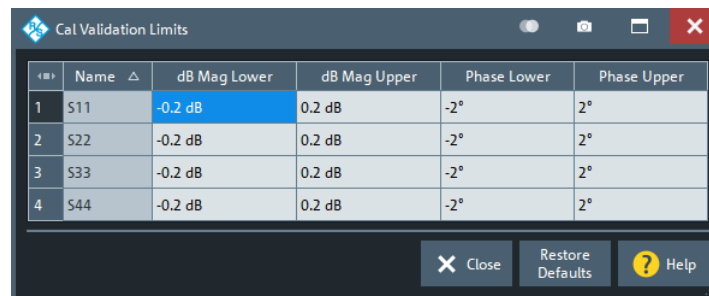

Defaults are ± 0.2 dB for magnitude and $\pm 2^\circ$ for phase deviations.

Remote command:

`CALCulate:CALValidate:RESPonse:MAGNitude:LOWer`

`CALCulate:CALValidate:RESPonse:MAGNitude:UPPer`

`CALCulate:CALValidate:RESPonse:PHASe:LOWer`

`CALCulate:CALValidate:RESPonse:PHASe:UPPer`

Preferences

Allows you to configure the behavior of the validation diagrams and traces.

Unchecking "Auto Scale" prevents the traces from scaling as the measurement and/or standard changes. Unchecking "Average On" turns off averaging.

Basic Mode

Switches to [Basic Mode](#)

6.11.2 Cal Devices Tab

Provides access to all functions for calibration kit management and cal unit characterization.



Background information

Refer to the following sections:

- [Chapter 5.5.2, "Calibration Standards and Calibration Kits"](#), on page 152
- [Chapter 5.5.5.3, "Characterization of Calibration Units"](#), on page 162

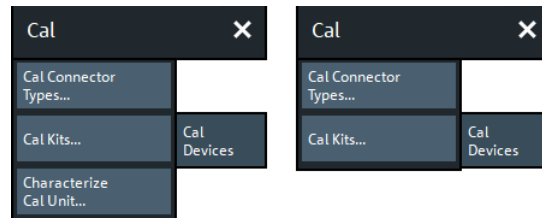

left = bidirectional R&S ZND
right = unidirectional R&S ZND

The buttons in the "Cal Devices" tab open the following dialogs:

- **"Cal Connector Types...":** See [Chapter 6.11.2.1, "Cal Connector Types Dialog"](#), on page 401
- **"Cal Kits...":** See [Chapter 6.11.2.2, "Calibration Kits Dialog"](#), on page 404
- **"Characterize Cal Unit...":** See [Chapter 6.11.2.3, "Characterize Cal Unit Dialog"](#), on page 409
For a unidirectional R&S ZND this button is not available.



For a unidirectional R&S ZND (see [Chapter 5.1.4.3, "R&S ZND: Unidirectional vs. Bidirectional Operation"](#), on page 75) calibration unit characterization is not available.

6.11.2.1 Cal Connector Types Dialog

The "Cal Connector Types" dialog displays and modifies the list of available connector types. Cal connector types must be selected in accordance with the connectors of the measured DUT.

Access: CHANNEL – [CAL] > "Cal Connector Types..."

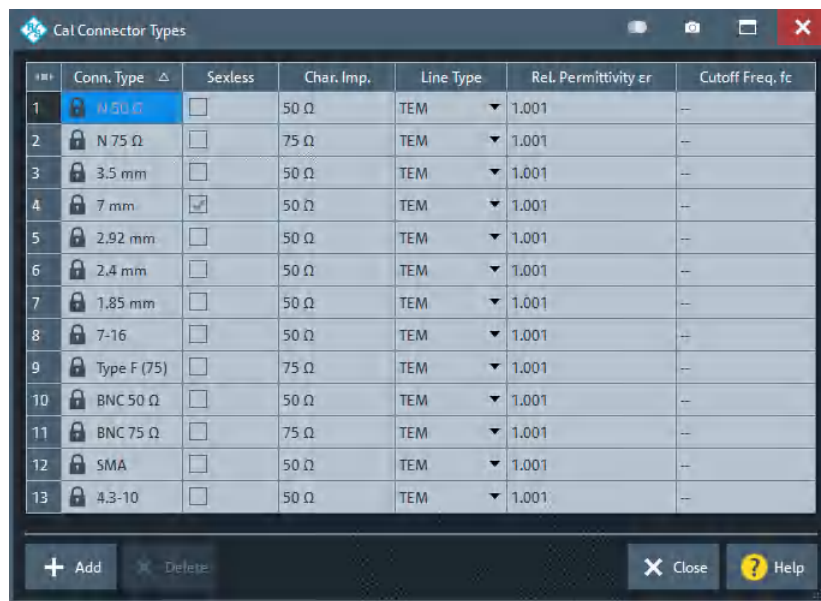

#	Conn. Type	Sexless	Char. Imp.	Line Type	Rel. Permittivity ϵ_r	Cutoff Freq. f_c
1	N 50 Ω	<input type="checkbox"/>	50 Ω	TEM	1.001	--
2	N 75 Ω	<input type="checkbox"/>	75 Ω	TEM	1.001	--
3	3.5 mm	<input type="checkbox"/>	50 Ω	TEM	1.001	--
4	7 mm	<input checked="" type="checkbox"/>	50 Ω	TEM	1.001	--
5	2.92 mm	<input type="checkbox"/>	50 Ω	TEM	1.001	--
6	2.4 mm	<input type="checkbox"/>	50 Ω	TEM	1.001	--
7	1.85 mm	<input type="checkbox"/>	50 Ω	TEM	1.001	--
8	7-16	<input type="checkbox"/>	50 Ω	TEM	1.001	--
9	Type F (75)	<input type="checkbox"/>	75 Ω	TEM	1.001	--
10	BNC 50 Ω	<input type="checkbox"/>	50 Ω	TEM	1.001	--
11	BNC 75 Ω	<input type="checkbox"/>	75 Ω	TEM	1.001	--
12	SMA	<input type="checkbox"/>	50 Ω	TEM	1.001	--
13	4.3-10	<input type="checkbox"/>	50 Ω	TEM	1.001	--

The list shows the available connector types with their name ("Conn. Type") and polarity ("Sexless"). The remaining columns in the list are described below.



Storing connector type settings

Calibration kits and connector types are global resources; the parameters are stored independently and available for all recall sets. The connector type settings are always stored together with the associated calibration kit parameters. The [Calibration Kits Dialog](#) provides buttons to export and import cal kit and connector settings.



After assigning a calibration kit to a user-defined connector type, you can still change its name, offset model and reference impedance. If you switch between sexed and sexless, all kits assigned to the connector type are deleted.

Char. Imp.

The characteristic impedance or reference impedance ("Char. Imp.") Z_0 for the connectors is a critical value that has an impact on various parameter conversions. Z_0 enters into:

- The calculation of the S-parameters for the calibration standards associated with the connector type, if they are derived from a circuit model (see ["View / Modify Cal Kit Standards Dialog"](#) on page 407).
- The calculation of the (default) reference impedances for balanced ports (see ["Reference Impedance Tab"](#) on page 229).
- The calculation of impedance and admittance parameters (see [Chapter 5.3.3, "Impedance Parameters"](#), on page 107 and [Chapter 5.3.4, "Admittance Parameters"](#), on page 111).

Remote command:

```
[SENSe<Ch>:]CORRection:CONNECTION
```

Line Type / Rel. Permittivity ϵ_r / Cutoff Freq. f_c

"Line Type" describes the wave propagation mode (offset model) in the transmission lines of the standards associated with the connector type.

- If the calibration kit standards contain lines with transverse electric propagation mode (TEM, e.g. coax cables), then the "Rel. Permittivity ϵ_r " of the dielectric can be defined. The default permittivity is the value for air. TEM-type lines have no cutoff frequency.
- If the calibration kit standards contain waveguides, then the lowest frequency where a wave propagation is possible ("Cutoff Freq. f_c ") can be defined. The default cutoff frequency is 0 Hz (propagation at all frequencies). No relative permittivity is needed for waveguides.

Note: The impedance for waveguides is frequency-dependent. If a waveguide line type is selected, various dialogs indicate "varies" instead of a definite impedance value.

Impact of line type parameters

The line type parameters are used for the calculation of the S-parameters for the calibration standards associated with the connector type, if they are derived from a circuit model (see ["View / Modify Cal Kit Standards Dialog"](#) on page 407).

- For TEM-type lines, the relative permittivity ϵ_r is needed for the conversion of a ZVR-type "Loss" (in units of dB/sqrt(GHz)) into a Keysight-type "Offset Loss" (in units of G Ω /s) and vice versa (see ["View / Modify Cal Kit Standards Dialog"](#) on page 407). The "Electrical Length" and "Delay" values in the [View / Modify Cal Kit Standards Dialog](#) are directly entered and therefore independent of ϵ_r .
- For waveguides, the low frequency cutoff frequency f_c is important because no wave propagation is possible at frequencies below f_c . If a standard is measured to acquire calibration data, the analyzer checks the low frequency cutoff. If the start frequency of the sweep range is below f_c , an error message is generated.

The offset model parameters are not used except in the context of calibration. The offset parameter definitions are based on independent ϵ_r values; see [Chapter 6.13.2, "Offset Tab"](#), on page 443.

Remote command:

```
[SENSe<Ch>:]CORRection:CONNection
```

Add / Delete

Adds or deletes a user-defined connector type. The parameters of a user-defined connector type can be modified in the table.

Note: Deleted/Missing Connector Types.

- Deleting a connector type also deletes all calibration or adapter kits assigned to it.
- Deleting a connector type that is used by a loaded recall set resets the affected ports to the instrument's connector type and gender.
- A setup can only be loaded if all its connector types (identified by their names) are configured at the target instrument.

Remote command:

```
[SENSe<Ch>:]CORRection:CONNection
```

```
[SENSe<Ch>:]CORRection:CONNection:CATalog?
```

```
[SENSe<Ch>:]CORRection:CONNection:DELeTe
```

6.11.2.2 Calibration Kits Dialog

The "Calibration Kits" dialog shows the available calibration kits for the different connector types. It is also used for cal kit and cal kit file management.

Access: CHANNEL – [CAL] > "Cal Devices" > "Cal Kits..."



Related information

Refer to the following sections:

- See also [Chapter 5.5.2, "Calibration Standards and Calibration Kits"](#), on page 152
- [Chapter 5.5.2.4, "Cal Kit Files"](#), on page 157
- [Chapter 5.5.2.2, "Cal Kit Parameter Types"](#), on page 155
- [Chapter 6.11.2.1, "Cal Connector Types Dialog"](#), on page 401

The contents of the "Available Cal Kits" table vary, depending on the selected "Connector Type". The table can also contain kits with ideal or typical parameter values; see [Cal Kit Parameter Types](#). The "Keysight Model" is an optional scheme to characterize the offset parameters of the standards; see ["Offset Parameters"](#) on page 408.



Cal kit labels

Assigning a "Label" to user-defined calibration kits is optional. However, the label is displayed in many dialogs and can provide useful information about the kit, e.g. its serial number. It is even possible to assign several calibration kits with the same name, distinguished by their label, to a common connector type. See also [Chapter 8.3.14.7, "\[SENSe:\]CORRection:CKIT... with Labels"](#), on page 903.

Controls in the Calibration Kits Dialog

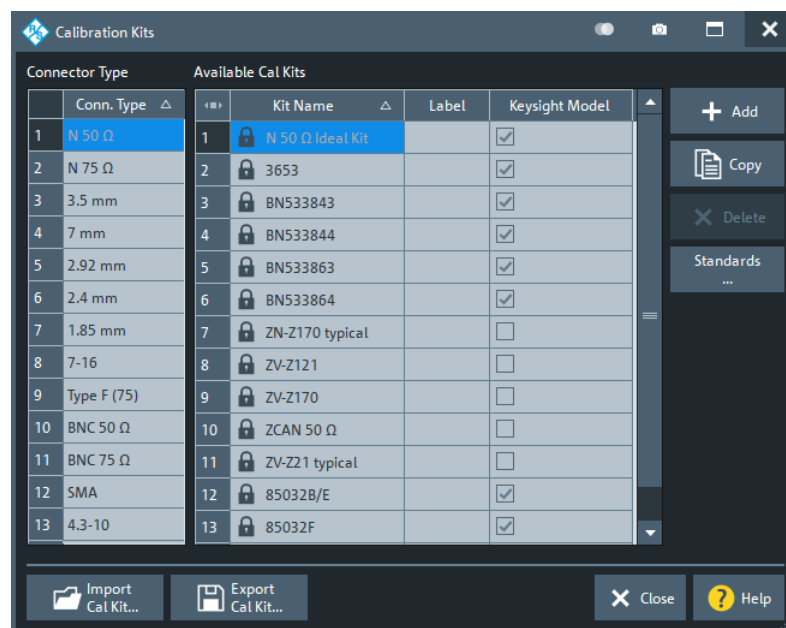

Connector Type

The "Connector Type" table displays the available cal kit connector types. Select a row in this table to get the list of [Available Cal Kits](#).

Remote command:

```
[SENSe<Ch>:]CORRection:CONNection:CATalog?
```

Available Cal Kits

Displays the cal kits for the selected [Connector Type](#)

Remote command:

```
[SENSe:]CORRection:CKIT:CATalog?
```

Add / Copy / Delete / Standards...

The buttons in the right part of the dialog are used to manage calibration kits:

- "Add" creates a cal kit file for the selected connector type.
- "Copy" creates a cal kit file based on the contents of an existing cal kit file.
- "Delete" deletes an imported or user-defined cal kit file.
- "Standards..." opens the "Kit Standards" dialog, which shows the contents of the cal kit file. For user-defined or imported kits, you can modify the contents. See "[Kit Standards Dialog](#)" on page 405.

Remote command:

The following commands create and modify calibration kits:

```
[SENSe:]CORRection:CKIT:<ConnType>:SElect
```

```
[SENSe:]CORRection:CKIT:<ConnType>:LSElect
```

```
[SENSe:]CORRection:CKIT:DMODE
```

```
[SENSe:]CORRection:CKIT:DElete
```

Query connector types and calibration kits:

```
[SENSe<Ch>:]CORRection:CONNection:CATalog?
```

```
[SENSe:]CORRection:CKIT:CATalog?
```

Import Cal Kit... / Export Cal Kit...

The buttons below the "Connector Type" list are used to store cal kit data to a file and to reload previously stored cal kit files. By default, calibration kit files are stored in the C:\Users\Public\Documents\Rohde-Schwarz\Vna\Calibration directory; see [Chapter 5.5.2.4, "Cal Kit Files"](#), on page 157.

Remote command:

```
MMEMory:LOAD:CKIT
```

```
MMEMory:STORe:CKIT
```

Kit Standards Dialog

The "Kit Standards" dialog shows the calibration standards in a selected calibration kit. It is also used to modify the contents of a user-defined kit.



Related information

Refer to the following sections:

- [Chapter 5.5.2.4, "Cal Kit Files"](#), on page 157
- [Chapter 6.11.2.2, "Calibration Kits Dialog"](#), on page 404
- [Chapter 5.5.2.1, "Calibration Standard Types"](#), on page 153

Access: [Calibration Kits Dialog](#) > "Standards..."

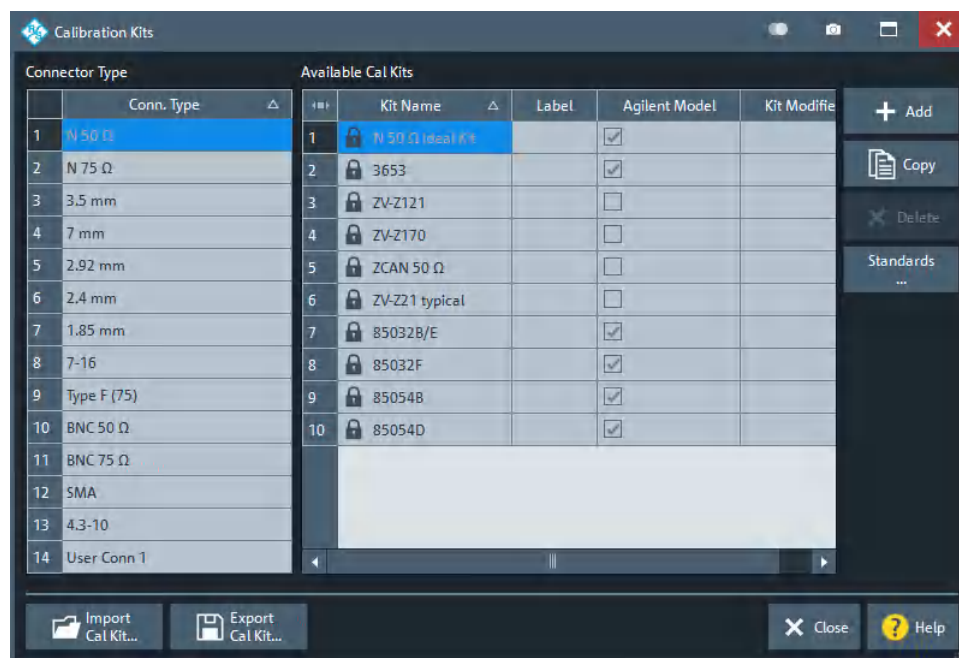

One port and two port standards are listed in two separate tables. Most of the buttons on the right side are available only if the "Kit Standards" dialog was opened for a user-defined calibration kit.

One Port Standards / Two Port Standards

The standard tables contain the following information:

- "Type" and "Gender" describe the calibration standard type; for an overview see [Chapter 5.5.2.1, "Calibration Standard Types"](#), on page 153.
- "Label" is a user defined name of the standard. The label can help you identify a standard or distinguish different standards with similar parameters.
- "Min Freq" and "Max Freq" define the rated frequency range of the standard. During calibration, the analyzer checks whether the sweep range is within the validity range of all measured standards and possibly generates a warning.
- ".s1p File" and ".s2p File" define whether the characteristics of the standard are described by a Touchstone file rather than by a circuit model from which the R&S ZND can calculate the S-parameters. See ["Read .s1p File... / Read .s2p File..."](#) on page 407 and ["View / Modify Cal Kit Standards Dialog"](#) on page 407.
- "Port" defines whether the standard can be connected to any analyzer port or to just one port (for one-port standards) or a pair of ports (for two-port standards).

Standards with unrestricted port assignment ("any") are stored with their gender. When a connector type and calibration kit is selected for the calibration, the analyzer checks whether the kit contains the required standard types and whether the standards have the right gender.

Standards with restricted port assignment are always assumed to have the gender that is appropriate for the calibrated port. The **port assignment** is stored in the calibration kit file, instead of the gender. During the calibration, the analyzer checks whether the cal kit contains the necessary standard types for the required ports.

Remote command:

```
[SENSe:]CORRection:CKIT:<StandardType>
[SENSe:]CORRection:CKIT:<ConnType>:SElect
```

Add / Copy... / Delete / View / Modify...

The buttons in the right part of the dialog are used to manage standards:

- "Add" adds a new standard to the calibration kit. The properties of the standard can be edited in the table.
- "Copy..." creates a standard based on the properties of an existing standard.
- "Delete" deletes the selected standard.
- "View / Modify..." opens the "View / Modify Cal Kit Standards" dialog. This dialog shows the circuit model for the selected standard. For user-defined standard, you can modify the circuit model parameters. See "[View / Modify Cal Kit Standards Dialog](#)" on page 407.

Remote command:

```
[SENSe:]CORRection:CKIT:<StandardType>
[SENSe:]CORRection:CKIT:<StandardType>:WLAbel
```

Read .s1p File... / Read .s2p File...

Opens a file selection dialog where you can select a Touchstone file containing the reflection or transmission S-parameters for the standard. The R&S ZND uses the imported S-parameters rather than the circuit model to characterize the standard, if ".s1p File"/".s2p File" is checked in the standard table. The appropriate file type (*.s1p for one-port standards and *.s2p for two-port standards) is selected automatically.

Remote command:

```
MMEMoRY:LOAD:CKIT:SDATa
```

View / Modify Cal Kit Standards Dialog

The "View / Modify Cal Kit Standards" dialog shows the circuit model for a selected calibration standard. It is also used to define or edit the circuit model (offset and load) parameters for a user-defined standard.



Related information

Refer to the following sections:

- [Chapter 5.5.2.4, "Cal Kit Files"](#), on page 157
- ["Kit Standards Dialog"](#) on page 405
- [Chapter 5.5.2.1, "Calibration Standard Types"](#), on page 153

Access: [Kit Standards Dialog](#) > "View / Modify..."

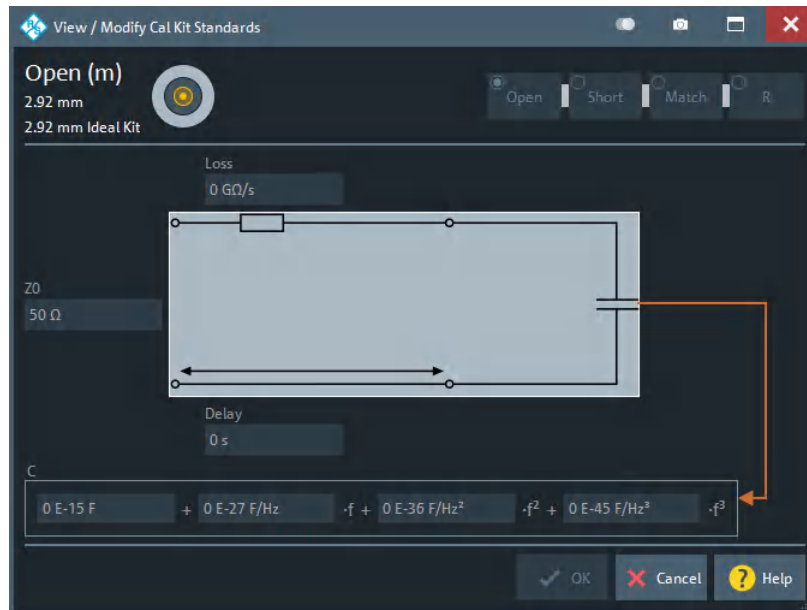

The diagram in the "View / Modify Cal Kit Standards" dialog depends on the standard type for which the dialog was opened. Moreover, it is possible to modify the circuit model using the buttons in the upper right of the dialog.

Offset Parameters

The entries in the upper part of the "View / Modify Cal Kit Standards" dialog specify the offset parameters for the transmission lines of the selected calibration standard.

The offset parameters depend on whether the circuit model is defined as "Keysight Model" (see [Chapter 6.11.2.1, "Cal Connector Types Dialog"](#), on page 401):

- In a "Keysight Model", a calibration standard is characterized by its "Delay" (in s), its characteristic impedance "Z0" (in Ω) and its "Offset Loss" (in G Ω /s).
- Otherwise the standard is characterized by the R&S ZVR-compatible parameters "Electrical Length" (in m), "Char. Imp." (in Ω) and "Loss" (in dB/sqrt(GHz)). The loss is zero and not editable as long as the electrical length is zero.

Both parameter sets are closely related. The "Electrical Length" is proportional to the "Delay"; "Z0" corresponds to the "Char. Imp.". Moreover the analyzer converts a Keysight-type "Offset Loss" into a R&S ZVR-type "Loss" and vice versa using the "Rel. Permittivity ϵ_r " for the selected connector type.

See also description of the offset parameters in [Chapter 5.5.2.1, "Calibration Standard Types"](#), on page 153.

Remote command:

```
[SENSe:]CORRection:CKIT:<StandardType>
```

Load Parameters

The entries in the lower part of the "View / Modify Cal Kit Standards" dialog specify the load parameters for a particular calibration standard describing its terminal impedance.

The circuit model for the load consists of capacitance C which is connected in parallel to an inductance L and a resistance R, both connected in series.

- R is the constant resistive contribution. It is possible to select:
 - "Open" for $\infty \Omega$ (so that the inductance coefficients are irrelevant)
 - "Short" for 0Ω
 - "Match" for the reference impedance of the current connector type
 - any resistance "R"
- The fringing capacitance C and the residual inductance L are both assumed to be frequency-dependent and approximated by the first four terms of the Taylor series around $f = 0$ Hz.

See also description of the load parameters for the different standard types in [Chapter 5.5.2.1, "Calibration Standard Types"](#), on page 153.

Remote command:

```
[SENSe:]CORRection:CKIT:<StandardType>
```

6.11.2.3 Characterize Cal Unit Dialog

The "Characterize Cal Unit" dialog displays the properties of the connected cal units, provides control elements for characterization file management, and starts the characterization wizard.

Access: CHANNEL – [CAL] > "Cal Devices" > "Characterize Cal Unit..."



Background information

Refer to [Chapter 5.5.5.3, "Characterization of Calibration Units"](#), on page 162.



A cal unit characterization can be performed in a frequency sweep. The "Characterize Cal Unit" dialog is unavailable while a "Power", "CW Mode", or "Time" sweep is active. The analyzer always uses a fixed source power of -10 dBm to acquire the characterization data.

Controls in the Characterize Cal Unit Dialog

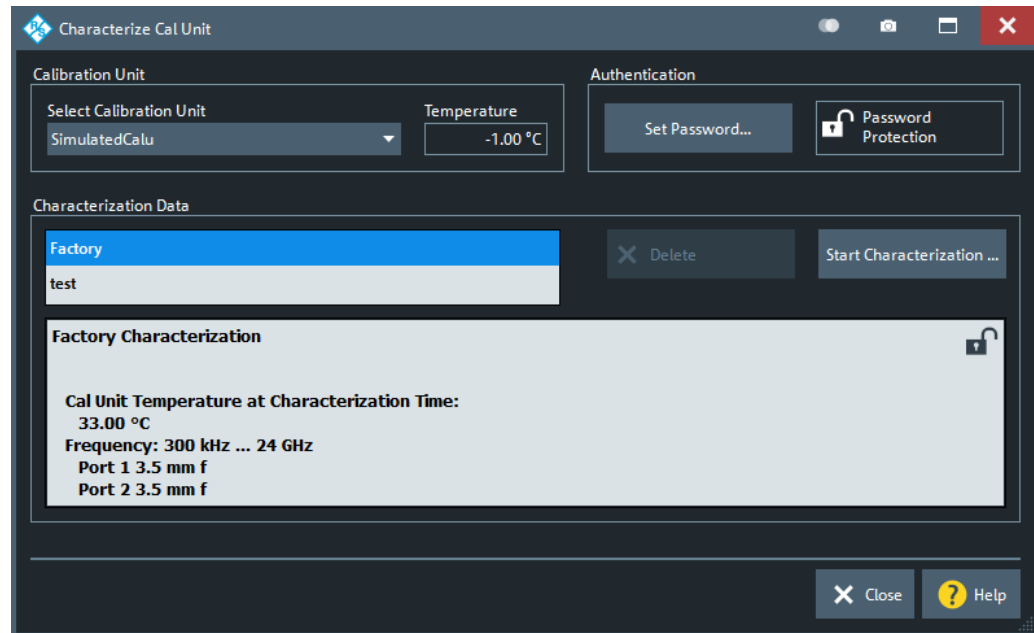

Calibration Unit

Displays the connected calibration units. The R&S ZND auto-detects all calibration units which are connected to one of its USB ports. If several cal units are connected, one of them must be selected for characterization (active cal unit).

Remote command:

```
SYSTem:COMMunicate:RDEvice:AKAL:ADDRESS:ALL?
SYSTem:COMMunicate:RDEvice:AKAL:ADDRESS
```

Authentication

Allows you to set a password to protect the characterization dialog and the [Characterization Wizard](#) from unauthorized access and operation. "Set Password..." opens a dialog to enter the password and activate password protection at the next time the "Set Password" dialog is opened. Enter an empty string (no password) to deactivate password protection.

Tip: A password also blocks a switchover of the active characterization during calibration; see ["Characterization"](#) on page 379.

Remote command:

```
[SENSe:]CORRection:COLLect:AUTO:CKIT:PASSWORD
```

Characterization Data

Displays all characterizations which are stored on the active cal unit. The "Factory" characterization is available for all calibration units; it ensures an accurate calibration for all standard applications. Characterizations stored on an SD card (inserted at the cal unit) are prefixed with "SD:".

Tip: Characterizations stored on an SD card (inserted at the cal unit) are prefixed with "SD:".

The properties of the selected characterization are shown below the list. "Delete" deletes the selected characterization file; "Start Characterization..." opens the [Characterization Wizard](#) to create a characterization.

Remote command:

```
SYSTem:COMMunicate:RDEvice:AKAL:CKIT:CATalog?
```

```
SYSTem:COMMunicate:RDEvice:AKAL:CKIT:STANdard:CATalog?
```

```
SYSTem:COMMunicate:RDEvice:AKAL:SDATa?
```

Characterization Wizard

The "Characterization" wizard guides you through the automatic characterization of a calibration unit.

Access: [Characterization Wizard](#) > "Start Characterization..."

The guided characterization consists of the following steps:

1. **"Characterization"**: Select the characterized ports and cal unit standards to initiate the characterization sweeps.
2. **"Save Characterization Data"**: Save the characterization data to the calibration unit.

Step 1: Characterization

Selects the calibration type and the characterized cal unit ports and initiates the necessary characterization sweeps.



Characterization procedure

To acquire accurate characterization data, the test setup must be properly calibrated before you start the characterization wizard. Use the calibration type that you wish to perform with your new cal unit characterization; see [Chapter 5.5.5.3, "Characterization of Calibration Units"](#), on page 162.



Test Port Assignment

Defines the assignment between test ports and cal unit ports. In the default "Manual" assignment, VNA ports and cal unit port numbers match. If you decide to use a different assignment, you can auto-detect the actual assignment ("Automatic") or select the analyzer port numbers manually. Auto-detection can fail, e.g., because of a high attenuation in the signal path.

Note: For a unidirectional R&S ZND (see [Chapter 5.1.4.3, "R&S ZND: Unidirectional vs. Bidirectional Operation"](#), on page 75) auto-detection at VNA port 2 does not work.

Remote command:

```
[SENSe<Ch>:]CORRection:COLLect:AUTO
[SENSe<Ch>:]CORRection:COLLect:AUTO:PORTs
[SENSe:]CORRection:COLLect:AUTO:PORTs:CONNection?
[SENSe:]CORRection:COLLect:AUTO:CKIT:PORTs
```

Take OSM / Take All OSM and Through

"Take OSM" starts a calibration sweep for the related port. "Take All OSM and Through" initiates a series of calibration sweeps; the R&S ZND acquires a full set of one-port and two-port data. The latter is required for the transmission normalizations and for a "One Path Two Ports" calibration; see ["Dependency between calibration types and characterization data"](#) on page 163.

Note: For a unidirectional R&S ZND (see [Chapter 5.1.4.3, "R&S ZND: Unidirectional vs. Bidirectional Operation"](#), on page 75) "Take OSM" only works at VNA port 1. Through characterization is not supported.

Remote command:

```
[SENSe<Ch>:]CORRection:COLLect:AUTO
[SENSe<Ch>:]CORRection:COLLect:AUTO:PORTs
[SENSe:]CORRection:COLLect:AUTO:PORTs:CONNection?
```

Next

Proceeds to [Step 2: Save Characterization Data](#) . Next is available when the R&S ZND has acquired characterization data for a single port.

Step 2: Save Characterization Data

Saves the characterization data to the calibration unit.

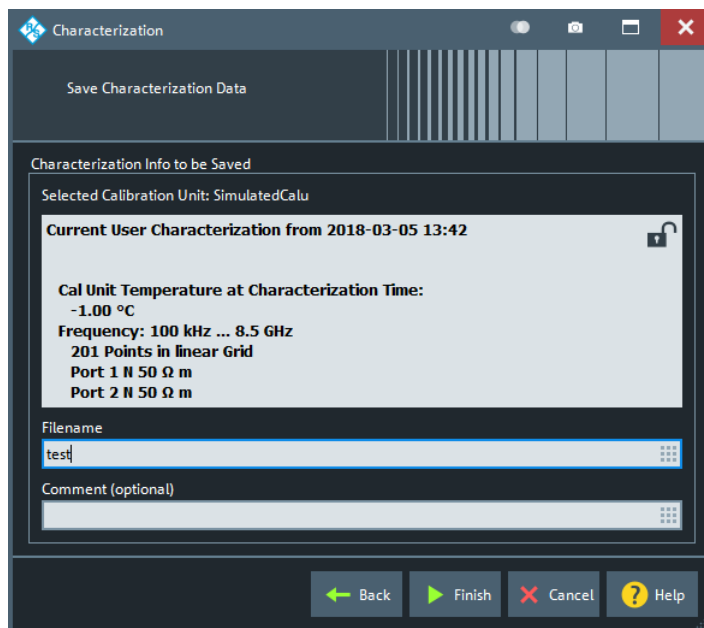

Figure 6-15: Save Characterization Data

Save File to SD Card

For all calibration units, characterization data can be saved to the calibration unit's internal flash memory. For some calibration units (e.g. the new models R&S ZN-Z5x and R&S ZN-Z15x), they can also be saved to an SD card inserted at the calibration unit. Activate this checkbox to save the characterization data to the SD card.

Tip: If the characterized calibration unit does not have an SD card slot, the checkbox is hidden. If the calibration unit has an SD card slot but the SD card is not accessible, the checkbox is grayed out.

File name / Comment (Optional)

Selects a filename to reference the characterization data set in the "Characterize Cal Unit" and "Calibration Unit" dialogs and a comment, to be written into the characterization file. A filename is required before you can "Finish" the characterization wizard and store the data.

Remote command:

[SENSe:]CORRection:COLLect:AUTO:CKIT

6.11.3 Pwr Cal Settings Tab

Gives access to all functions for power meter and power calibration data handling (transmission coefficients). Power calibration of the R&S ZND is a fully menu-guided process.



Efficient power calibration procedure

- For standard applications, open the "Start Cal" tab and select "Scalar Power Cal" – "Power Cal..." to perform the necessary calibration sweeps with default power calibration settings. You do not need any of the buttons in the "Pwr Cal Settings" tab.
- Select "Cal Power..." if you use an amplifier between the source port and the DUT.
- Select "Transm. Coefficients..." if you want to modify the power calibration procedure.



Background information

Refer to [Chapter 5.5.6, "Scalar Power Calibration"](#), on page 167.

6.11.3.1 Controls on the Pwr Cal Settings Tab

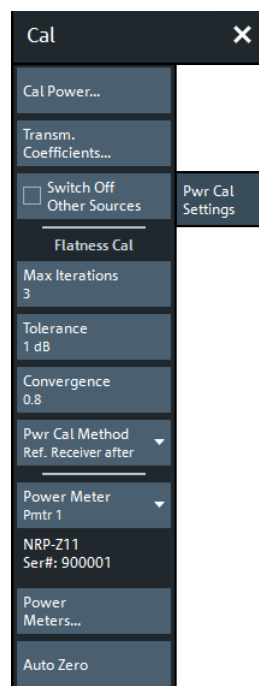

Some buttons serve as openers for additional dialogs:

- "Cal Power...": see [Chapter 6.11.3.2, "Modify Cal Power Dialog"](#), on page 416
- "Transm. Coefficients...": see [Chapter 6.11.3.3, "Power Meter Transmission Coefficients Dialog"](#), on page 418
- "Power Meters...": see [Chapter 5.7.19, "External Power Meters"](#), on page 208

Switch Off Other Sources

Ensures that the power at all sources except the calibrated source is switched off during the calibration. Recommended, if the measurement involves a combination of different signals.

Remote command:

```
SOURce<Ch>:POWer<PhyPt>:CORRection:OSources[:STATe]
```

Flatness Cal – Max Iterations

Sets a limit for the number of calibration sweeps. See also "[Calibration procedure](#)" on page 168.

Remote command:

```
SOURce<Ch>:POWer<PhyPt>:CORRection:NREadings
SOURce<Ch>:POWer<PhyPt>:CORRection:COLLect:AVERAge[:COUNT]
```

Flatness Cal – Tolerance

Defines the maximum deviation of the measured power from the cal power. The calibration procedure is stopped if "Max Iterations" is reached or if the measured power is within the "Tolerance".

Remote command:

```
SOURce<Ch>:POWer<PhyPt>:CORRection:COLLect:AVERAge:NTOLerance
```

Flatness Cal – Convergence

Modifies the amount of power correction for each of the flatness calibration sweeps. The power correction in each sweep, as controlled by the calibrated reference receiver (a-wave receiver), is multiplied by the selected convergence factor. With a convergence factor larger (smaller) than 1, the source power correction after each flatness calibration step is larger (smaller) than the measured deviation from the desired power.

For analyzer test ports, a convergence factor 1 is appropriate. It is recommendable to start the calibration with a convergence factor 1 and choose smaller values (0.8 ... 0.4) in case that the iteration fails. Inappropriate convergence factors can slow down the flatness calibration or even prevent convergence.

Remote command:

```
SOURce<Ch>:POWer<PhyPt>:CORRection:COLLect:CFACTOR
```

Flatness Cal – Pwr Cal Method

Defines how power calibrations are performed.

"Ref. Receiver after"	Use a power meter for the calibration of the reference receiver, and the calibrated reference receiver for the flatness calibration.
"Power Meter only"	Use a power meter for the calibration of the reference receiver <i>and</i> the flatness calibration.
"Ref. Receiver only"	Perform a flatness calibration using the reference receiver. Do not recalibrate the reference receiver; use the best available reference receiver calibration instead.

"Ref. Receiver after" is the default behavior.

Remote command:

```
SOURce<Ch>:POWer<PhyPt>:CORRection:COLLect:METHod
```

Embedding

Defines whether the source flatness cal uses the configured offset de-/embedding to get the power values at the DUT (instead of the calibrated reference plane).

This setting applies to all ports and channels. Default is "Off" (no offset or de-/embedding used).

Remote command:

```
SOURce:POWer:CORRection:COLLect:VNETworks
```

Power Meter

Shows a list of all power meters that have been properly configured and are available for the power calibration of a source port. The last configured power meter is selected by default. See ["Configured Devices"](#) on page 544.

Remote command:

```
SOURce:POWer:CORRection:PMETer:ID
```

Auto Zero

Initiates an automatic zeroing procedure of the power meter; see ["Zeroing"](#) on page 210.

Remote command:

```
SYSTem:COMMunicate:RDEvice:PMETer<Pmtr>:AZERo
```

6.11.3.2 Modify Cal Power Dialog

The "Modify Cal Power" dialog adjusts the target power for the power calibration (cal power) and defines the target power for the reference receiver calibration. These settings are particularly important for test setups involving external attenuators or amplifiers.

Access: CHANNEL – [CAL] > "Pwr Cal Settings" > "Cal Power..."

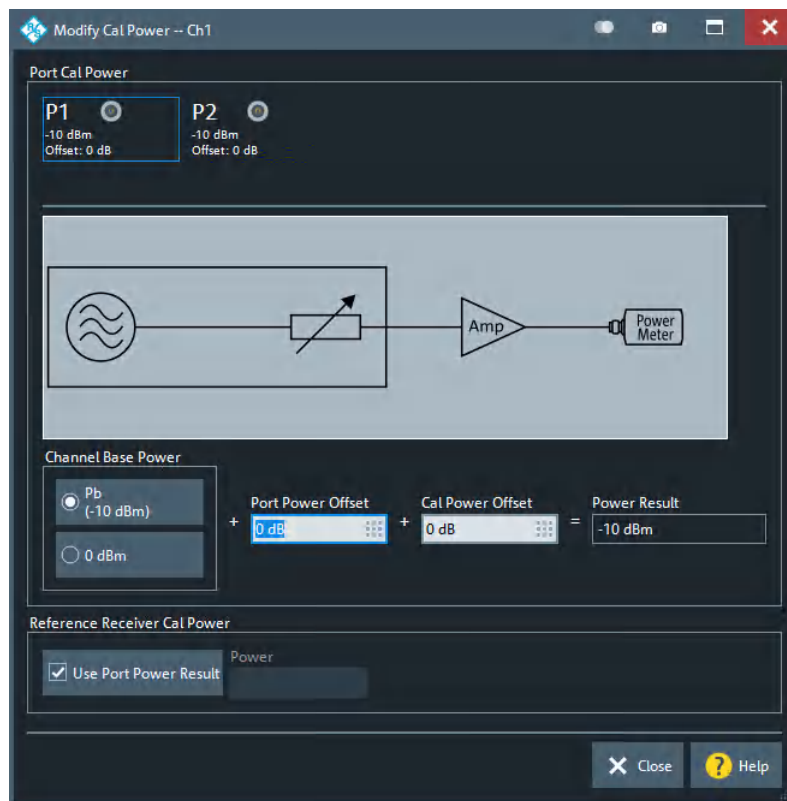

The diagram in the center of the dialog visualizes the settings and results below.

Port Cal Power

Allows you to define (port-specific) power levels for source power calibrations.

Port Overview ← Port Cal Power

The dialog shows all source ports of the network analyzer. Each port is displayed with the current "Power Result" at the input of the DUT (in dBm) and offset (i.e. the "Cal Power Offset" in dB).

Remote command:

```
SOURce<Ch>:POWER<PhyPt>[:LEVEL][:IMMEDIATE]:OFFSET
SOURce<Ch>:POWER<PhyPt>:CORREction:LEVEL:OFFSET
```

Channel Base Power ← Port Cal Power

Allows you to select between the channel base power P_b and a fixed value of 0 dBm.

Remote command:

```
SOURce<Ch>:POWER<PhyPt>[:LEVEL][:IMMEDIATE]:OFFSET
```

Port Power Offset ← Port Cal Power

Defines a port-specific offset to the [Channel Base Power](#). The actual output power at the port is equal to the "Channel Base Power" plus the "Port Power Offset".

If P_b is selected as "Channel Base Power", then for a power sweep the actual port power varies across the sweep. Otherwise the port power is constant.

Remote command:

```
SOURce<Ch>:POWer<PhyPt>[:LEVel] [:IMMediate]:OFFSet
```

Cal Power Offset ← Port Cal Power

For power calibrations only: Specifies a gain (positive values) or an attenuation (negative values) in the signal path between the source port and the calibrated reference plane. With a "Cal Power Offset" of n dB, the target power at the reference plane (cal power) is equal to the actual output power at the port plus n dB. The "Cal Power Offset" has no impact on the source power.

Example: Use of an amplifier in the signal path

Assume that a DUT requires a constant input power of +25 dBm, and that the measurement path contains an amplifier with a 30 dB gain. After a reset of the analyzer, the channel power P_b is -10 dBm. Select a "Port Power Offset" of +5 dB at the calibrated source port and a "Cal Power Offset" of +30 dB. Then the source power calibration ensures that the constant input power of +25 dBm is maintained across the entire sweep range. The actual output power of the analyzer is -5 dBm.

Notice that a power calibration with an appropriate "Cal Power Offset" can prevent excess input levels at the DUT.

Remote command:

```
SOURce<Ch>:POWer<PhyPt>:CORRection:LEVel:OFFSet
```

Reference Receiver Cal Power

Defines the source power settings the R&S ZND uses to perform the first calibration sweep of the source power calibration.

In this first sweep, the power meter reading is used to calibrate the reference receiver of the calibrated port. The following calibration sweeps are based solely on the reference receiver (see ["Calibration procedure"](#) on page 170).

By default, the "Reference Receiver Cal Power" is set to the resulting [Port Cal Power](#). However, the accuracy of the source power calibration depends on the power meter's measurement accuracy. Therefore it is advantageous to select a "Reference Receiver Cal Power" at which the power meter provides maximum accuracy.

Note: Risk of damage due to high power settings. If an external device (e.g. an amplifier) is connected between the calibrated test port and the power meter, ensure that the "Reference Receiver Cal Power" does not exceed its maximum input power.

Remote command:

```
SOURce<Ch>:POWer<PhyPt>:CORRection:PSElect
SOURce:POWer:CORRection:PPOWer
```

6.11.3.3 Power Meter Transmission Coefficients Dialog

The "Power Meter Transmission Coefficients" dialog allows you to modify the results of a scalar power calibration to account for an additional two-port device (with known transmission characteristics) in the test setup.

Access: CHANNEL – [CAL] > "Pwr Cal Settings" > "Transm. Coefficients..."



Background information

Refer to [Chapter 5.5.6.4, "Extended Test Setups"](#), on page 171.

Controls in the Power Meter Transmission Coefficients Dialog

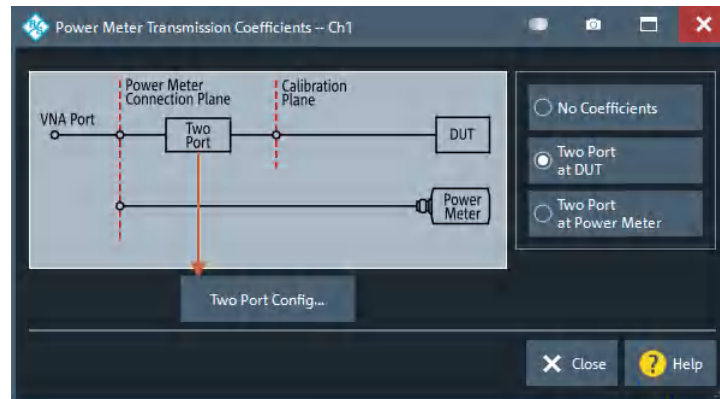

Test Setup

The button group on the right of the dialog allows you to select a test setup with an additional two-port device. This device can be located in front of the DUT (during the measurement) or in front of the power meter (during power calibration). "No Coefficients" disables the transmission coefficients but does not delete the entries in the [Two Port Configuration Dialog](#).

Remote command:

```
SOURce<Ch>:POWER<PhyPt>:CORRection:TCoefficient[:STATE]
SOURce<Ch>:POWER<PhyPt>:CORRection:TCoefficient:CALibration
```

Two Port Config...

Opens the "Two Port Configuration" dialog that allows you to define the transmission coefficients of the additional two-port device. See ["Two Port Configuration Dialog"](#) on page 419.

The button is disabled if "No Coefficients" is active. However, once you have configured the two-port device, you can disable it without losing its configuration.

Two Port Configuration Dialog

The "Two Port Configuration" dialog defines the transmission characteristics of an additional two-port in the calibrated frequency range.

Access: [Power Meter Transmission Coefficients Dialog](#) > "Two Port Config..."

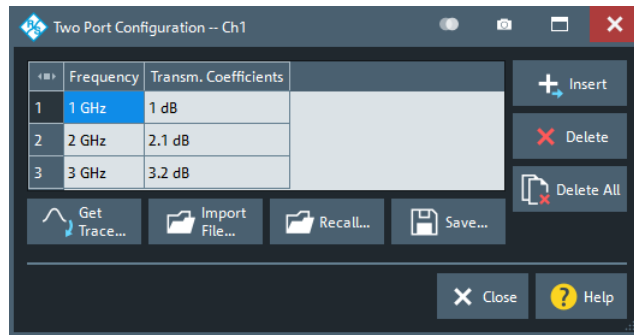

Frequency / Transm. Coefficients: Insert, Delete, Delete All

The required two-port information is a list of transmission coefficients at different frequency values (power loss list). The buttons in the dialog provide different ways of creating and modifying the list. Use "Insert", "Delete", "Delete All" to edit the list manually.

In a power, time or CW mode sweep, one point at the fixed CW frequency is sufficient. In a frequency sweep, it is possible to enter several coefficients to account for a frequency-dependent attenuation. Transmission coefficients are interpolated between the frequency points and extrapolated, if necessary.

If no transmission coefficient is defined at all, the R&S ZND assumes a 0 dB attenuation across the entire frequency range. This assumption is equivalent to an ideal through connection or selecting "No Coefficients" in the [Power Meter Transmission Coefficients Dialog](#).

Remote command:

```
SOURce<Ch>:POWer<PhyPt>:CORRection:TCoefficient:INSert<ListNo>
SOURce<Ch>:POWer<PhyPt>:CORRection:TCoefficient:DEFine<ListNo>
SOURce<Ch>:POWer<PhyPt>:CORRection:TCoefficient:COUNT?
SOURce<Ch>:POWer<PhyPt>:CORRection:TCoefficient:DELeTe<ListNo>[:
DUMMy]
SOURce<Ch>:POWer<PhyPt>:CORRection:TCoefficient:DELeTe<ListNo>:
ALL
```

Get Trace...

Opens a selection box containing all traces in the active recall set. The "dB Mag" values of the selected trace are used to define the transmission coefficients. Notice that if you combine different channels with different sweep points, the analyzer possibly has to interpolate or extrapolate the transmission coefficients.

Remote command:

```
SOURce<Ch>:POWer<PhyPt>:CORRection:TCoefficient:FEED
```

Import File...

Imports the transmission coefficients from a trace file. The imported file must be either in Touchstone (*.s<n>p) or in *.csv format; see also [Chapter 5.4.2, "Trace Files"](#), on page 129.

Remote command:

```
MMEMoRY:LOAD:CORRection:TCoefficient<Ch>
```

Recall... / Save...

You can save the displayed power loss list to a power meter correction list file with extension (*.pmc1) and reload it in later sessions.

Remote command:

```
MMEMory:LOAD:CORRection:TCoefficient<Ch>
```

```
MMEMory:STORe:CORRection:TCoefficient<Ch>
```

6.11.4 Use Cal Tab

Provides access to functions for activating, deactivating and managing calibrations.

**Background information**

Refer to the following sections:

- [Chapter 5.5, "Calibration"](#), on page 140

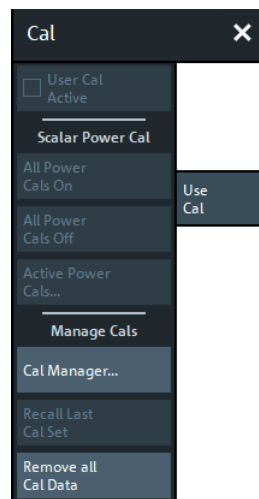
6.11.4.1 Controls on the Use Cal Tab

The buttons in the "Use Cal" tab open the following dialogs:

- "Scalar Power Cal" – "Active Power Cals...": [Active Power Cals Dialog](#)
- "Manage Cals" – "Cal Manager...": See [Calibration Manager Dialog](#)

User Cal Active

Activates or deactivates the system error correction in the active channel. "User Cal Active" is available only if a valid system error correction is available for the active channel; see "Channel State" in [Chapter 6.11.4.3, "Calibration Manager Dialog"](#), on page 423.

Note: A label "Cal Off" appears behind the trace list if the system error correction is switched off; see also [Chapter 5.5.4, "Calibration Labels"](#), on page 158. The calibration status of each channel and trace appears in the setup information ("Setup" > "Info..." > "Setup").

Remote command:

```
[SENSe<Ch>:]CORRection[:STATe]
```

Scalar Power Cal – All Power Cals On / All Power Cals Off

Activates or deactivates all scalar power calibrations in the active channel. "All Power Cals On" is only available if a valid power calibration is available for the active channel, but not active; see "Channel State" in [Chapter 6.11.4.3, "Calibration Manager Dialog"](#), on page 423.

Note: A label "PCal Off" appears behind the trace list of a wave quantity or a ratio if the power calibration is switched off; see also [Chapter 5.5.6.3, "Power Calibration Labels"](#), on page 170. The calibration status of each channel and trace appears in the setup information (see ["Setup Tab"](#) on page 534).

Remote command:

```
[SENSe<Ch>:]CORRection:PCAL
```

Manage Cals – Recall Last Cal Set

Loads and activates the recall set for which the last calibration was performed. If the last calibrated setup is already active, nothing is changed. The calibrated setups are automatically stored in the

```
C:\Users\Public\Documents\Rohde-Schwarz\Vna\Calibration\
RecallSets
```

 directory. A message box pops up if the directory is empty, e.g. because no calibration was performed yet.

Remote command:

n/a

Remove all Cal Data

This button cleans the active channel's existing calibration data and also removes links to the calibration pool.

Remote command:

```
[SENSe<Ch>:]CORRection:DELeTe
```

6.11.4.2 Active Power Cals Dialog

The "Active Power Cals" dialog shows the power calibrations that are compatible with the active channel configuration. It allows you to enable or disable the available power calibrations.

Access: CHANNEL – [CAL] > "Use Cal" > "Active Power Cals..."

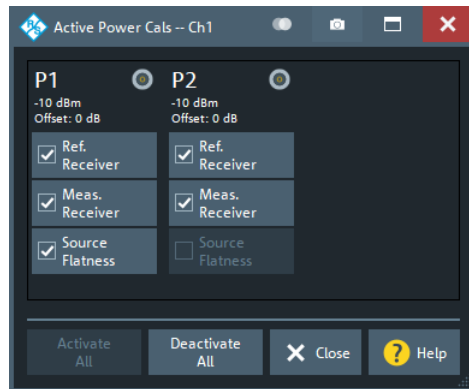

All possible power calibrations can be performed from the [Power Cal Wizard](#).

Port Overview

Shows all source ports together with their possible power calibrations. Unavailable calibrations (i.e. calibrations that have not been performed yet) are grayed out.

Note: For a unidirectional R&S ZND (see [Chapter 5.1.4.3, "R&S ZND: Unidirectional vs. Bidirectional Operation"](#), on page 75) P2 cannot serve as source port. Hence only a calibration of the measurement receiver can be performed at P2.

Remote command:

```
SOURCE<Ch>:POWER<PhyPt>:CORREction:STATe
[SENSE<Ch>:]CORREction:POWER<PhyPt>[:STATe]
[SENSE<Ch>:]CORREction:PCAL
```

6.11.4.3 Calibration Manager Dialog

The "Calibration Manager" dialog stores user correction data to the cal pool and assigns stored correction data to channels.

See [Chapter 5.5.3, "Calibration Pool"](#), on page 158 for background information.

Access: CHANNEL – [CAL] > "Use Cal" > "Cal Manager..."

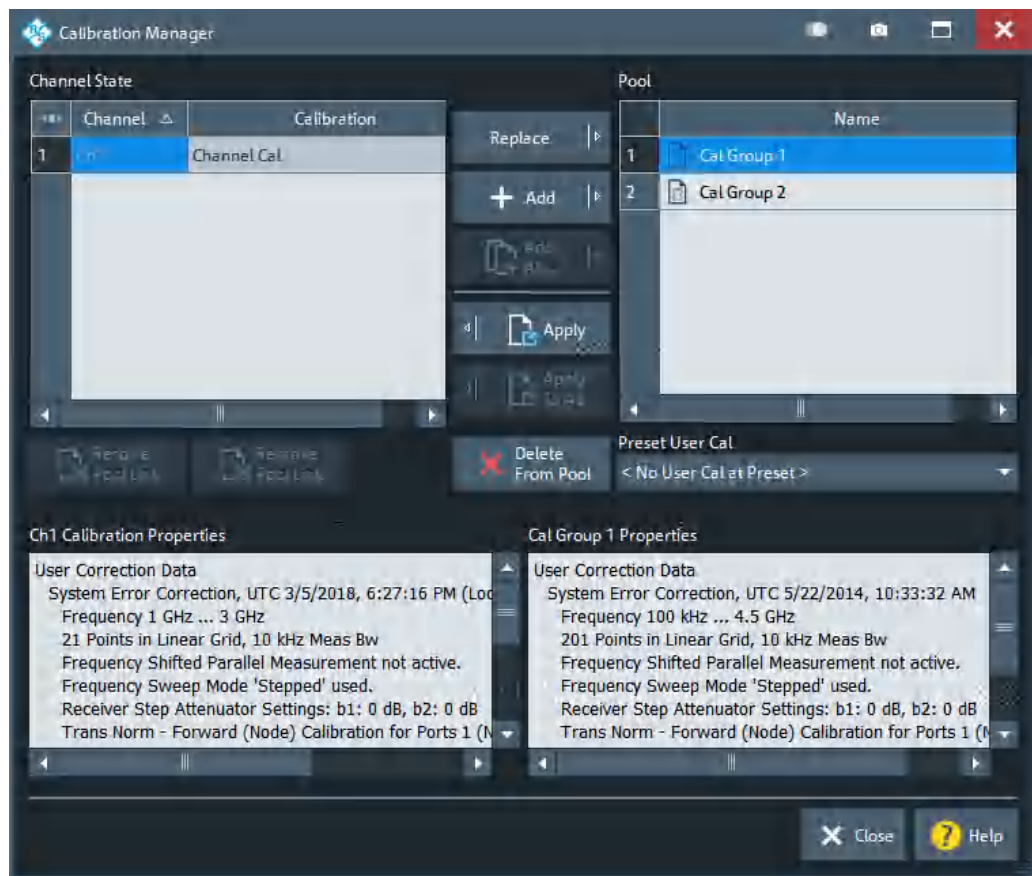

Channel State

The "Channel State" table shows all channels in the active recall set together with their current calibration. Channels can use either the active channel calibration (if available), a previously stored user correction data or the factory system error correction (indicated as '--').

Remote command:
n/a

Add / Add All... / Replace / Apply / Apply to All

The buttons between the tables are used to modify the calibration pool and apply calibration data sets (cal groups) to channels:

- "Add" copies the correction data of the selected channel to the cal pool, generating a new pool member (cal group).
- "Add All..." copies the correction data of all channels to the cal pool, generating new pool members (cal groups).
- "Replace" overwrites a cal group with new correction data.
- "Apply" assigns the selected cal group to the selected channel.
- "Apply to All" assigns the selected cal group to all channels in the "Channel State" table.

For channels that are linked to a "Cal Group" (using "Apply" or "Apply to All"), a new calibration overwrites the cal group data and hence affects all channels that are also linked to this cal group. An "Overwrite Warning" is displayed in this case. To continue with the calibration, confirm by using button "Overwrite Current File?" or "[Resolve Pool Link / Remove Pool Link](#)" on page 425.

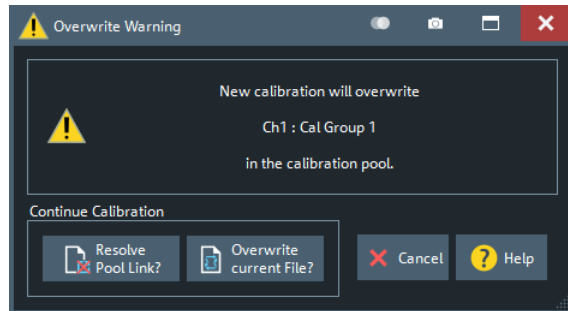

Remote command:

```
MMEMory:STORe:CORRection
MMEMory:LOAD:CORRection
MMEMory:LOAD:CORRection:MERGe
```

Pool / Delete from Pool

The "Pool" table shows all correction data sets `<CalGroup_name>.cal` in the directory `C:\Users\Public\Documents\Rohde-Schwarz\Vna\Calibration\Data`. The name of a pool data set can be modified directly in the corresponding table cell.

"Delete from Pool" deletes a cal group file from the pool. **Note** however, that calibrations being used in any of the opened recall sets cannot be deleted.

Remote command:

```
MMEMory:DELeTe:CORRection
```

Preset User Cal

Selects a cal group from the pool that is activated during a user-defined preset.

A "Preset User Cal" is particularly useful for scenarios involving [External Switch Matrices](#), because with switch matrices user correction is indispensable.

Remote command:

```
SYSTem:PRESet:USER:CAL
```

Resolve Pool Link / Remove Pool Link

Deletes a link between the selected channel and a "Cal Group" (previously created using "Apply" or "Apply to All"). With "Resolve Pool Link", the cal group data are still used as a channel calibration ("Channel Cal") for this channel. With "Remove Pool Link" the channel calibration is removed.

Remote command:

```
MMEMory:LOAD:CORRection:RESolve
```

Ch<n> Calibration Properties/Cal Group <n> Properties

Displays the basic channel settings and the properties of the system error correction and the power correction for the channel (calibration group) selected in the "Channel State" ("Pool") table.

In addition, it is stated whether sweep data are available for the selected calibration.

Remote command:

```
[SENSe<Ch>:]CORRection:DATE?
```

```
[SENSe<Ch>:]CORRection:DATA:PARAmeter<Sfk>?
```

```
[SENSe<Chn>:]CORRection:SSTate?
```

6.12 Channel Config Softtool

The "Channel Config" functions select, create and delete channels and optimize the measurement process.

Access: CHANNEL – [CHANNEL CONFIG] hardkey

6.12.1 Channels Tab

Allows you to create and delete channels, to modify the channel state, and to select a channel as the active channel.



You can monitor the channel activity using the `OUTPut<Ch>:UPORt[:VALue]` command and the output signals at pins 8 to 11 of the USER PORT connector.



Background information

Refer to [Chapter 5.1.3.3, "Active and Inactive Traces and Channels"](#), on page 72.

6.12.1.1 Controls on the Channels Tab

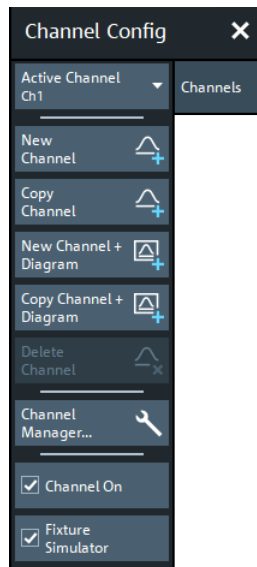

The buttons in the "Channels" tab open the following dialogs:

- "Channel Manager...": see [Chapter 6.12.1.2, "Channel Manager Dialog"](#), on page 429

Active Channel

Selects an arbitrary channel of the active recall set as the active channel. This function is disabled if the current recall set contains only one channel.

If one or several traces are assigned to the selected channel, one of these traces becomes the active trace.

The order of all channels in a recall set is given by the channels' creation time. By default, the channels are named Ch1, Ch2, ... so that Ch<n – 1> precedes Ch<n>. This order is always maintained, even if channels are renamed, invisible (because no traces are assigned to them) or distributed over several diagram areas.

Tip: You can also select a line in the channel list to activate the corresponding channel.

Remote command:

The numeric suffix <Ch> appended to the first-level mnemonic of a command selects a channel as the active channel.

New Channel

Creates a channel and a trace with default settings, and assigns the new trace to the active diagram area.

The new channel is named Ch<n>, where <n> is the largest of all existing channel numbers plus one. The name can be changed in the "Channel Manager" dialog.

Tips:

- To create a channel and a trace with default settings and to display the trace in a *new* diagram area, use [New Channel + Diagram](#).
- Use [Add Trace](#) to create a trace in the *active* channel.

Remote command:

```
CONFigure:CHANnel<Ch>[:STATe] ON
CALCulate<Ch>:PARAmeter:SDEFine
DISPlay[:WINDow<Wnd>]:TRACe<WndTr>:FEED
CONFigure:TRACe<Trc>:CHANnel:NAME?
CONFigure:TRACe<Trc>:CHANnel:NAME:ID?
```

Copy Channel

Copies the active channel with all its settings (including a possible channel calibration) and traces. The new traces are displayed in the active diagram area.

The new channel is named Ch<n>, where <n> is the largest of all existing channel numbers plus one. The name can be changed in the "Channel Manager" dialog.

Tips: Use [Copy Channel + Diagram](#) to display the copied traces in a *new* diagram area.

Remote command:

```
CONFigure:CHANnel<Ch>[:STATe] ON
CALCulate<Ch>:PARAmeter:SDEFine
DISPlay[:WINDow<Wnd>]:TRACe<WndTr>:FEED
CONFigure:TRACe<Trc>:CHANnel:NAME?
CONFigure:TRACe<Trc>:CHANnel:NAME:ID?
```

New Channel + Diagram

Creates a channel and a trace with default settings, and assigns the created trace to a new diagram area.

The new channel is named Ch<n>, where <n> is the largest of all existing channel numbers plus one. The name can be changed in the "Channel Manager" dialog.

Tip: To create a channel and a trace with default settings and to display the trace in the *active* diagram area, use [New Channel](#).

Copy Channel + Diagram

Copies the active channel with all its settings (including a possible channel calibration) and traces, and displays the created traces in a new diagram area.

The new channel is named Ch<n>, where <n> is the largest of all existing channel numbers plus one. The name can be changed in the "Channel Manager" dialog.

Tips: Use [Copy Channel](#) to display the new traces in an *existing* diagram area.

Delete Channel

Deletes the current channel including all the traces assigned to it and removes all display elements related to the channel from the diagram area. "Delete Channel" is disabled if the recall set contains only one channel: In manual control, each recall set must contain at least one diagram area with one channel and one trace.

Tips: Use the "Undo" function to restore a channel that was unintentionally deleted.

Remote command:

```
CONFigure:CHANnel<Ch>[:STATe] OFF
```

Channel On

Toggles the measurement state of the [Active Channel](#).

Remote command:

```
CONFigure:CHANnel<Ch>:MEASure[:STATe]
```

Fixture Simulator

The "Fixture Simulator" switch deactivates or activates the configured deembedding, embedding, balanced ports, and port impedance settings for the selected channel.

When "Fixture Simulator" is **deactivated**:

- all balanced ports are resolved to single ended ports
- all port impedances are set to default
- all de/embeddings are disabled

At the GUI, the "Balanced Ports" dialog and the de/embedding tabs and dock widgets are disabled. Related remote commands generate an error.

When "Fixture Simulator" is **reactivated**, the situation before the deactivation is restored.

Note: The "Offset" and "One Way Loss" settings are **not** affected by the "Fixture Simulator" switch. Use the "All Compensation Off"/"All Compensation On" functions of the "Fixture Compensation" dialog to de/activate these compensations as well (see [Chapter 6.13.2.2, "Fixture Compensation Dialog"](#), on page 447).

Remote command:

```
CALCulate<Ch>:TRANSform:VNETworks:FSIMulator[:STATe]
```

6.12.1.2 Channel Manager Dialog

The "Channel Manager" dialog allows you to rename channels and to change their measurement state and sweep mode.

Access: CHANNEL – [CHANNEL CONFIG] > "Channels" > "Channel Manager..."

**Background information**

Refer to [Chapter 5.1.3.3, "Active and Inactive Traces and Channels"](#), on page 72.

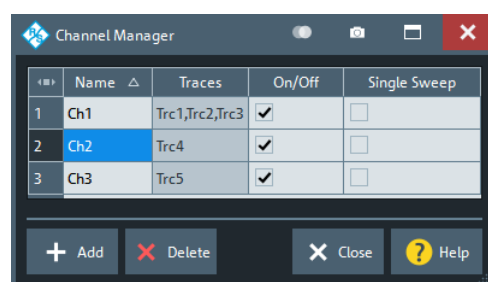
**Channel table**

The rows and columns of the channel table represent the existing channels (rows) together with certain editable (white) or non-editable (gray) properties (columns).

- "Name" indicates the name of the related channel.
- "Traces" indicates the names of all traces assigned to the related channel.

- "On/Off" toggles the measurement state of the related channel.
- "Single Sweep" toggles between "Continuous" and "Single" sweep mode (see ["Continuous / Single"](#) on page 370).

Remote command:

```
CONFigure:CHANnel:CATalog?
CONFigure:CHANnel<Ch>:NAME
CONFigure:CHANnel<Ch>:NAME:ID?
CONFigure:CHANnel<Ch>:MEASure[:STATe]
INITiate<Ch>:CONTinuous
```

Add / Delete

The buttons below the channel table add and delete channels.

- "Add" adds a new channel to the list. The new channel is named Ch<n>, where <n> is the largest of all existing channel numbers plus one.
- "Delete" deletes the channel selected in the table. This button is disabled if the setup contains only one channel: In manual control, each setup must contain at least one diagram area with one channel and one trace.

Remote command:

```
CONFigure:CHANnel<Ch>[:STATe]
```

6.12.2 Port Config Tab

Configures the ports of the R&S ZND.

6.12.2.1 Controls on the Port Config Tab

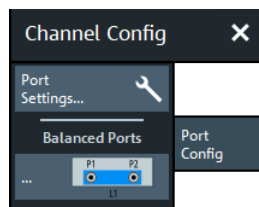

If the "Fixture Simulator" is disabled for the related channel (see ["Fixture Simulator"](#) on page 429), the "Balanced Ports..." button is inactive (grayed out).

Port Settings...

Opens a dialog that allows you to configure the ports of the R&S ZND: see [Chapter 6.12.2.2, "Port Settings Dialog"](#), on page 431.

Balanced Ports...

Opens a dialog that allows you to enable/disable physical ports and to define logical ports (balanced or unbalanced) in the active channel. See [Chapter 6.2.1.3, "Balanced Ports Dialog"](#), on page 226.

Note: If the "Fixture Simulator" is disabled for the related channel (see ["Fixture Simulator"](#) on page 429), the "Balanced Ports..." button is inactive (grayed out).

6.12.2.2 Port Settings Dialog

The "Port Settings" dialog is an example of a [Multi-channel Setup Dialog](#). It allows you to switch the RF port power off or on and gives convenient access to the stimulus settings for the selected channel.

Access: CHANNEL – [CHANNEL CONFIG] > "Port Config" > "Port Settings..."

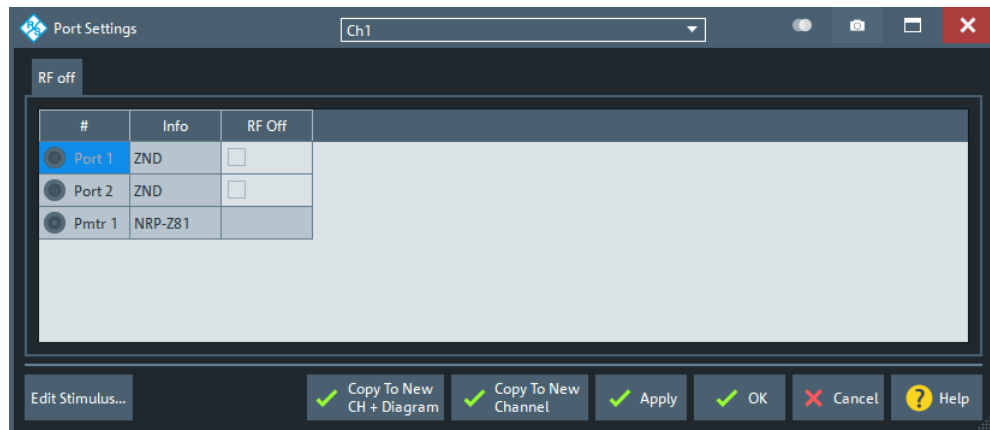

Related information

Refer to the following sections:

- [Chapter 6.17.4.2, "External Power Meters Dialog"](#), on page 543

Common Controls

Modified "Port Settings" take effect on "Apply" or "OK". Use "Cancel" to discard possible changes.

For non-segmented sweeps, the "Edit Stimulus..." button opens the [Stimulus Dialog](#), that allows you to access the stimulus settings without having to leave the "Port Settings" dialog.

Stimulus Dialog

The "Stimulus" dialog gives access to the parameters of a non-segmented sweep.

Access: [Port Settings Dialog](#) > "Edit Stimulus..."

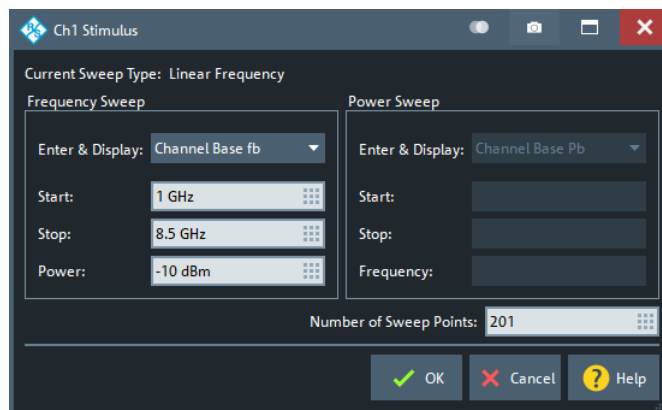

Figure 6-16: Stimulus Dialog: Linear Frequency Sweep

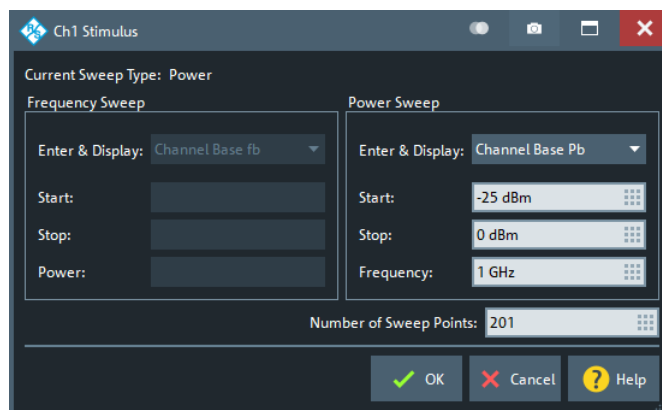

Figure 6-17: Stimulus Dialog: Power Sweep

All these parameters can also be set in the [Sweep Softtool](#). Depending on the channel's [Sweep Type](#), a different set of parameters can be modified.

Enter & Display

The "Enter & Display" combo boxes in the "Frequency Sweep" and "Power Sweep" sections of the "Stimulus" dialog control how frequency and power values are entered and displayed.

- channel base frequency fb/power
- frequency/power at logical port i
- source frequency/power at logical port i
- receiver frequency at logical port i

Note that setting "Enter & Display" to a particular port, source, or receiver is only possible if option R&S ZND-K4 is available. Furthermore, a particular port, source, or receiver can only be selected, if the user-defined linear function for calculating the respective frequency/power is not constant.

6.12.3 Mode Tab

Optimizes the measurement process.

6.12.3.1 Controls on the Mode Tab

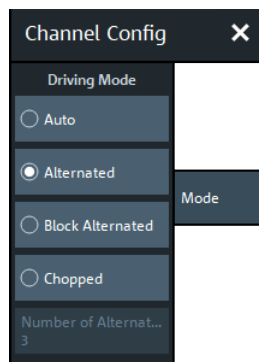

Driving Mode

Determines the order of partial measurements and sweeps.

- In "Auto" mode, the analyzer optimizes the display update: Fast sweeps are performed in "Alternated" mode, slower sweeps in "Chopped" mode.
- In "Alternated" mode, a partial measurement is performed at all sweep points (partial sweep) before the hardware settings are changed. The next partial measurement is carried out in an additional sweep. This mode is usually faster than "Chopped" mode.
- In "Block Alternated" mode, you can split the sweep range into several blocks of sweep points. The measurement then proceeds block per block, using the "Alternated" driving mode for each block.
- In "Chopped" mode, the analyzer completes the necessary sequence of partial measurements at each sweep point and obtains the result (measurement point) before proceeding to the next sweep point. A trace is obtained from the beginning of the sweep.

The "Driving Mode" setting is also used during a system error correction. For channels which require a single partial measurement only, the driving mode settings are equivalent. See also [Chapter 5.1.4.1, "Partial Measurements and Driving Mode"](#), on page 73.

Remote command:

```
[SENSe<Ch>:]COUPlE
```

Number of Alternated Blocks

Defines the number of blocks for the "Block Alternated" [Driving Mode](#).

If "Number of Alternated Blocks" is set to 1, "Block Alternated" is equivalent to "Alternated" mode. If it is set to the [number of sweep points](#), "Block Alternated" is equivalent to "Chopped" mode. By selecting a suitable [number of blocks](#), you can minimize the total sweep duration.

Note:

- If the number of sweep points is not divisible by the number of blocks, the first block is extended by the excessive number sweep points.
- For segmented sweeps the "Block Alternated"/"Number of Alternated Blocks" logic is applied to the individual sweep segments.

Remote command:

```
[SENSe<Ch>:]COUPlE BLOCk, <Number of Alternated Blocks>
```

6.12.4 Pwr Cal Settings Tab

Replicates the "Pwr Cal Settings" tab of the "Cal" softtool (see [Chapter 6.11.3, "Pwr Cal Settings Tab"](#), on page 414).

6.13 Offset Embed Softtool

The "Offset Embed" softtool allows you to define a length offset and loss for each test port. The offset compensates for the known length and loss of (non-dispersive and perfectly matched) transmission lines between the calibrated reference plane and the DUT. It also contains advanced functions for deembedding/embedding the DUT from/into more general physical/virtual (matching) networks placed between the calibrated reference plane and the DUT.

Access: CHANNEL – [OFFSET EMBED]



Background information

Refer to [Chapter 5.6, "Offset Parameters and De-/Embedding"](#), on page 173

6.13.1 Offset Embed Dock Widget

On activating a tab in the "Offset Embed" softtool, a dock widget is displayed beneath the trace area, whose content pane is synchronized with the selected softtool tab.

Access: CHANNEL – [OFFSET EMBED]

6.13.1.1 Overview Panel

Shows an overview of the overall calculation flow and provides quick access to the "Offset Embed" functions.

Access: CHANNEL – [OFFSET EMBED] > "Overview"

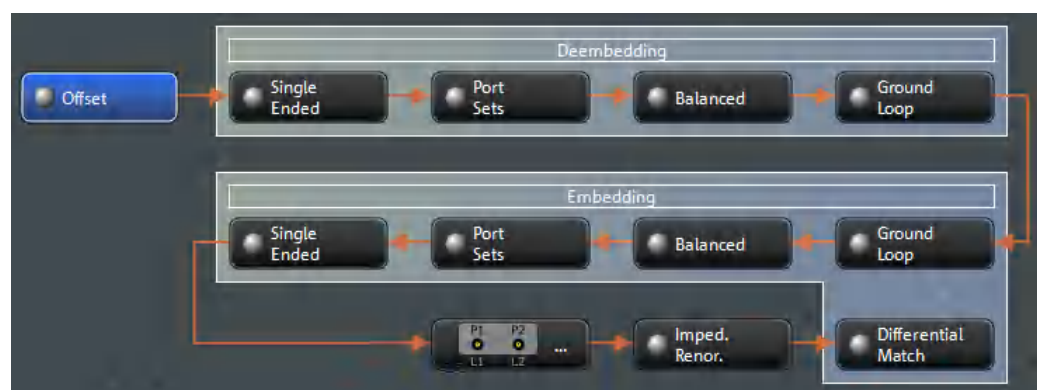

Figure 6-18: Offset Embed dock widget: Overview (Calculation Flow)

Use one of the buttons to configure the corresponding function. A green LED on a button indicates that the corresponding deembedding/embedding function is active.



If the "Fixture Simulator" is disabled for the related channel (see "Fixture Simulator" on page 429), all functions except the "Offset" function are inactive (grayed out in the "Overview").

6.13.1.2 Offset Panel

Allows you to activate or deactivate offset/loss correction for selected physical ports and to set related parameters.

Access: Overview Panel > "Offset"

Offset									
Offset	Active	Delay	Loss at DC	Loss at 1st Freq	1st Freq for Loss	Use 2nd Freq	Loss at 2nd Freq	2nd Freq for Loss	
P1 L1	<input checked="" type="checkbox"/>	0 s	0 dB	0 dB	1 GHz	<input type="checkbox"/>	0 dB	500 MHz	Reset Offsets
P2 L2	<input checked="" type="checkbox"/>	0 s	0 dB	0 dB	1 GHz	<input type="checkbox"/>	0 dB	500 MHz	All Offsets On
									All Offsets Off
									Displayed Columns...

Figure 6-19: Offset Embed dock widget: Offset panel

The "Offset" panel can also be activated by selecting the [Offset Tab](#) or [One Way Loss Tab](#). Refer to its description for additional functions and remote commands.

Active

The checkbox in the "Active" column activates/deactivates the configured length and loss parameters for the respective [Port](#) (i.e. adds/removes them to/from the calculation flow) without changing the parameter values.

Remote command:

```
[SENSe<Ch>:]CORRection:OFFSet<PhyPt>:COMPensation[:STATe]
```

Loss at DC / Loss at 1st Freq / 1st Freq for Loss / Use 2nd Freq / Loss at 2nd Freq / 2nd Freq for Loss

Defines the one-way loss parameters of the transmission line at the selected port.

In the limit case, where the length of the transmission line is considered to be "almost zero", the loss is considered constant:

$$Loss(f) = Loss_{DC}$$

Otherwise, if the loss at DC and one additional frequency f_1 is known, the loss at frequency f is approximated by:

$$Loss(f) = Loss_{DC} + (Loss(f_1) - Loss_{DC}) \cdot \sqrt{\frac{f}{f_1}}$$

If, in addition, the loss at a second frequency f_2 is known and "Use 2nd Freq" is enabled, then the loss is approximated by:

$$Loss(f) = Loss_{DC} + (Loss(f_1) - Loss_{DC}) \cdot \left(\frac{f}{f_1}\right)^b, \text{ where } b = \frac{\log_{10}\left(\left|\frac{Loss(f_1)}{Loss(f_2)}\right|\right)}{\log_{10}\left(\frac{f_1}{f_2}\right)}$$

See also [Chapter 5.6.1.2, "Definition of Loss Parameters"](#), on page 174.

Note: The entered parameters define the loss for a signal traveling in **one direction** through the transmission line. To account for the propagation in both directions, the magnitude shift of a reflection parameter due to a given loss is twice the magnitude shift of a transmission parameter. See also [Chapter 5.6.1.6, "Application and Effect of Offset Parameters"](#), on page 178.

Remote command:

```
[SENSe<Ch>:]CORRection:LOSS<PhyPt>:OFFSet
[SENSe<Ch>:]CORRection:LOSS<PhyPt>
[SENSe<Ch>:]CORRection:LOSS<PhyPt>:FREQuency
[SENSe<Ch>:]CORRection:LOSS<PhyPt>:SECond:STATe
[SENSe<Ch>:]CORRection:LOSS<PhyPt>:SECond
[SENSe<Ch>:]CORRection:LOSS<PhyPt>:SECond:FREQuency
```

Reset Offsets

The "Reset Offsets" button resets the length and loss parameters for all ports to their default values.

Remote command:

```
[SENSe<Ch>:]CORRection:OFFSet<PhyPt>[:STATe]
```

All Offsets On / All Offsets Off

Activates/deactivates the length and loss compensation for all ports.

Use the checkboxes in the [Active](#) column to activate/deactivate the length and loss compensation for selected ports.

Remote command:

```
[SENSe<Ch>:]CORRection:OFFSet<PhyPt>:COMPensation[:STATe]
```

Displayed Columns

Opens a dialog that lets you select between different ways to specify the offset, similar to [Delay / Electrical Length / Mech. Length](#) on the [Offset Tab](#).

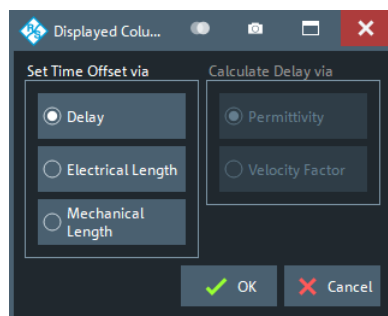

6.13.1.3 Single Ended Panel

Allows you to activate or deactivate single ended deembedding/embedding for selected physical ports. For the "2-Port Data" network type, it is also possible to change the underlying `s2p` Touchstone file from the dock widget.

Access: [Overview Panel](#) > "Single Ended"

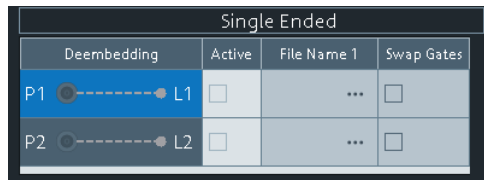

The "Single Ended" panel can also be activated by selecting the [Single Ended Tab](#) softtool tab. Refer to its description for background information, parameters and additional remote commands.

Active

The checkbox in the "Active" column activates or deactivates the selected "Single Ended" de-/embedding [Single Ended Tab](#) (i.e. adds or removes it to/from the calculation flow) without changing its parameters.

Remote command:

```
CALCulate<Ch>:TRANSform:VNETworks:SENDED:DEEMbedding<PhyPt>[:STATE]
```

```
CALCulate<Ch>:TRANSform:VNETworks:SENDED:EMBedding<PhyPt>[:STATE]
```

File Name 1 / Swap Gates

The ellipsis button in the "File Name 1" column is enabled as long as the "2-Port Data" network is selected (see [Single Ended Tab](#)). This network is defined by its S-parameters stored in a two-port Touchstone file (* .s2p). No additional parameters are required.

When loading the touchstone file, the analyzer by default assumes odd ports left (VNA side), even ports right (DUT side). However, it is also possible to **"Swap Gates"**, instructing the analyzer to reinterpret the loaded S-parameters (e.g. $S_{12} \rightarrow S_{21}$).

Note: The loaded S-parameters are stored in the active recall set. Recall sets contain the full embedding and deembedding data so that they can be transferred to other instruments.

Remote command:

```
MMEMemory:LOAD:VNETworks<Ch>:SENDED:DEEMbedding<PhyPt>
```

```
MMEMemory:LOAD:VNETworks<Ch>:SENDED:EMBedding<PhyPt>
```

6.13.1.4 Port Sets Panel

The "Port Sets" panel allows you to configure the "Port Sets" to whom a deembedding or embedding network can be assigned ("Add", "Delete"). The touchstone files defining these networks can also be selected from here ("...").

Access: [Overview Panel](#) > "Port Sets"

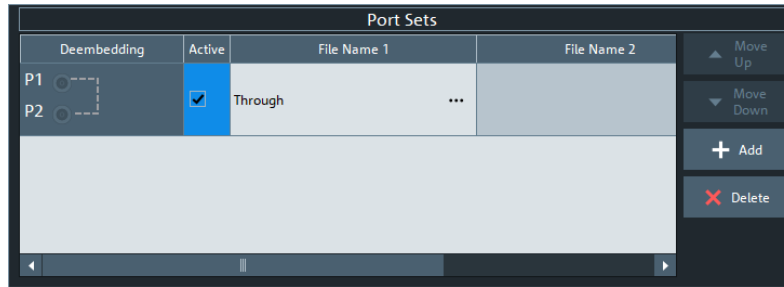

The "Port Sets" panel can also be activated by selecting the [Port Sets Tab](#). Refer to its description for background information, parameters and additional remote commands.

Move Up / Move Down

Allows you to modify the sequence in which the active port set deembeddings/embeddings are applied.

Add / Delete

Allows you to define the "Port Sets" to whom a deembedding or embedding network can be assigned.

The "Add" button opens the "Define Port Set" dialog that allows you to define an additional port set, comprising two ports (in arbitrary order).

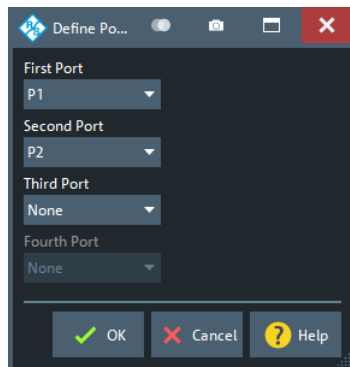

Use the controls on the right-hand side of the dialog to define the port set and the order of the ports within the port set.

Remote command:

```
CALCulate<Ch>:TRANSform:VNETworks:PPAir:DEEMbedding<ListId>:
DEFine
```

```
CALCulate<Ch>:TRANSform:VNETworks:PSET:DEEMbedding<ListId>:
DEFine
```

```
CALCulate<Ch>:TRANSform:VNETworks:PPAir:DEEMbedding:DELeTe
```

```
CALCulate<Ch>:TRANSform:VNETworks:PPAir:EMBedding<ListId>:DEFine
```

```
CALCulate<Ch>:TRANSform:VNETworks:PSET:EMBedding<ListId>:DEFine
```

```
CALCulate<Ch>:TRANSform:VNETworks:PPAir:EMBedding<ListId>:DELeTe
```

Active

The checkboxes in the "Active" column activate or deactivate the configured de-/embedding for the related port set (i.e. adds or removes it to/from the calculation flow) without changing its parameters.

Remote command:

```
CALCulate<Ch>:TRANSform:VNETworks:PPAir:DEEMbedding<ListId>[:STATE]
```

```
CALCulate<Ch>:TRANSform:VNETworks:PPAir:EMBedding<ListId>[:STATE]
```

File Name <i>/Inc. Seq. <i>

The "File Name 1" (and "File Name 2") buttons are enabled as long as the selected deembedding/embedding [Port Sets Tab](#) is defined using one or two Touchstone file(s).

When loading a touchstone file, the analyzer by default assumes odd ports left (VNA side), even ports right (DUT side). However, it is also possible to instruct the analyzer to assume an "Increasing Port Sequence", i.e. that the low port numbers are on the VNA side. Furthermore it is possible to "Swap Gates", i.e. to instruct the analyzer to swap the VNA and DUT side.

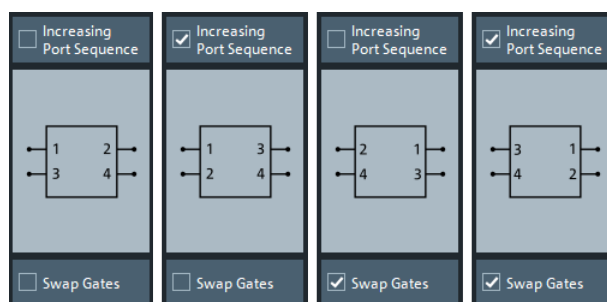

Note: The loaded file is stored in the active recall set. Persisted recall sets contain the full (de-)embedding data so that they can be transferred to other instruments.

Remote command:

```
MMEMory:LOAD:VNETworks<Ch>:PPAir:DEEMbedding<ListId>
```

```
MMEMory:LOAD:VNETworks<Ch>:PPAir:EMBedding<ListId>
```

6.13.1.5 Balanced Panel

This panel allows you to activate or deactivate deembedding/embedding of balanced ports.

Access: [Overview Panel](#) > "Balanced"

If the selected [Balanced Tab](#) is defined using a touchstone file, this file can be selected from the dock widget ("...").

For network types that are defined using one or more touchstone files, the required files can also be selected from here ("...").

If necessary, use the button on the right-hand side to open the [Balanced Ports Dialog](#) and change the balanced port configuration.

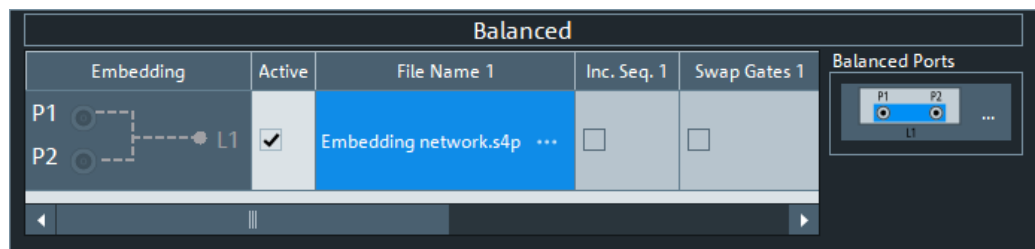

This panel can also be activated by selecting the [Balanced Tab](#). Refer to its description for background information, parameters and additional remote commands.

Active

The checkboxes in the "Active" column activate or deactivate the configured de-/embedding for the related balanced port (i.e. adds or removes it to/from the calculation flow) without changing its parameters.

Remote command:

```
CALCulate<Ch>:TRANSform:VNETworks:BALanced:DEEMbedding<LogPt>[:STATE]
```

```
CALCulate<Ch>:TRANSform:VNETworks:BALanced:EMBedding<LogPt>[:STATE]
```

File Name <i>/Swap Gates

The ellipsis button in the "File Name <i>" column is enabled as long as the selected [Balanced Tab](#) comprises a two-port or four-port data network (*.s2p or *.s4p file).

When loading a touchstone file, the analyzer by default assumes odd ports left (VNA side), even ports right (DUT side). However, it is also possible to instruct the analyzer to assume an "Increasing Port Sequence", i.e. that the low port numbers are on the VNA side. Furthermore it is possible to "Swap Gates", i.e. to instruct the analyzer to swap the VNA and DUT side.

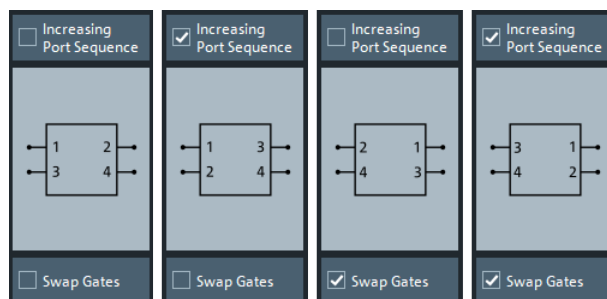

Note: The loaded S-parameters are stored in the active recall set. Persisted recall sets contain the full embedding and deembedding data so that they can be transferred to other instruments.

Remote command:

```
MMEMemory:LOAD:VNETworks<Ch>:BALanced:DEEMbedding<LogPt>
```

```
MMEMemory:LOAD:VNETworks<Ch>:BALanced:EMBedding<LogPt>
```

Balanced Ports

Provides access to the [Balanced Ports Dialog](#) that allows you to modify the balanced port configuration.

6.13.1.6 Ground Loop Panel

Allows you to activate or deactivate ground loop deembedding/embedding ("Active").

Access: [Overview Panel](#) > "Ground Loop"

For the "1-Port Data" network type, the required touchstone file can also be selected from here ("...").

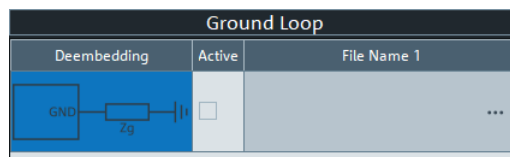

This panel can also be activated by selecting the [Ground Loop Tab](#) softtool tab. Refer to its description for background information, parameters and additional remote commands.

Active

The checkboxes in the "Active" column activate or deactivate the configured ground loop deembedding/embedding (i.e. adds or removes it to/from the calculation flow) without changing its parameters.

Remote command:

```
CALCulate<Ch>:TRANSform:VNETworks:GLOop:DEEMbedding[:STATe]
```

```
CALCulate<Ch>:TRANSform:VNETworks:GLOop:EMBedding[:STATe]
```

File Name 1

The ellipsis button in the "File Name 1" column is enabled if a 1-port data [Network](#) network (*.s1p file) is selected.

Note: The loaded S-parameter trace is stored in the active recall set. Persisted recall sets contain the full embedding and deembedding data so that they can be transferred to other instruments.

Remote command:

```
MMEMorY:LOAD:VNETworks<Ch>:GLOop:DEEMbedding
```

```
MMEMorY:LOAD:VNETworks<Ch>:GLOop:EMBedding<group>
```

6.13.1.7 Impedance Renormalization Panel

This panel provides alternative access to the reference impedance settings (see "[Reference Impedance Tab](#)" on page 229).

Access: [Overview Panel](#) > "Impedance Renor."

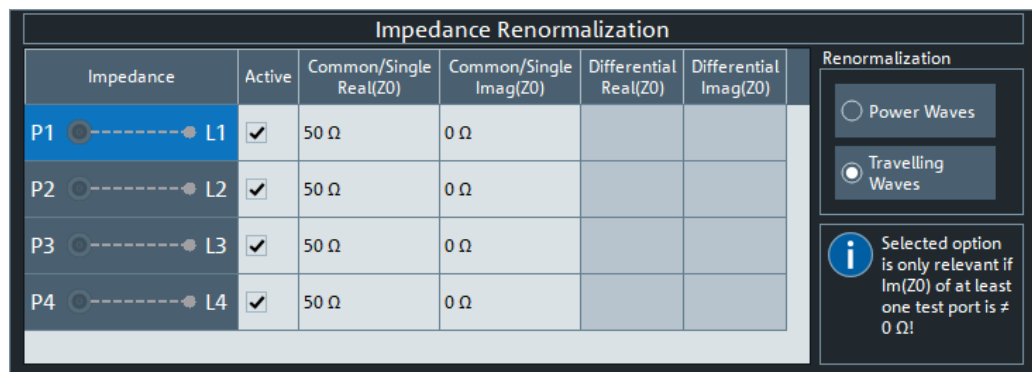

For a unidirectional R&S ZND (see [Chapter 5.1.4.3, "R&S ZND: Unidirectional vs. Bidirectional Operation"](#), on page 75) balanced measurements are not available and hence the columns for the "Differential" mode impedance are hidden.

Active

The "Active" flags are inversely related to the [Use Default](#) flags of the logical port configuration (see [Balanced Ports Dialog](#)).

"Active"	"Use Default"
<input checked="" type="checkbox"/>	<input type="checkbox"/>
<input type="checkbox"/>	<input checked="" type="checkbox"/>

6.13.1.8 Differential Match Panel

This panel allows you to activate or deactivate differential match embedding.

Access: [Overview Panel](#) > "Differential Match"

For the "2-Port Data" network type, the required touchstone file can also be selected from here ("...").

If necessary, use the button on the right hand side to open the [Balanced Ports Dialog](#) and change the balanced port configuration.

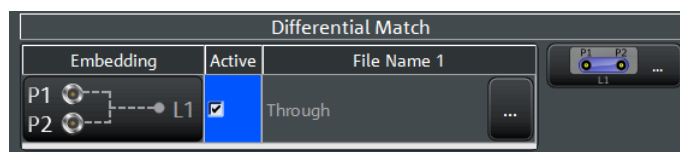

This panel can also be activated by selecting the [Differential Match Tab](#) softtool tab. Refer to its description of this softtool tab for background information, parameters and additional remote commands.

Active

The checkboxes in the "Active" column activate or deactivate the configured differential match embedding (i.e. adds or removes it to/from the calculation flow) without changing its parameters.

Remote command:

```
CALCulate<Ch>:TRANsform:VNETworks:DIFFerential:  
EMBedding<LogPt>[:STATE]
```

File Name 1

The ellipsis button in the "File Name 1" column is enabled if a 2-port data [Network](#) is selected.

When loading the touchstone file (*.s2p), the analyzer by default assumes odd ports left (VNA side), even ports right (DUT side). However, it is also possible to **"Swap Gates"**, instructing the analyzer to reinterpret the loaded S-parameters (e.g. S_{12} --> S_{21}).

Note: The loaded S-parameter traces are stored in the active recall set. Persisted recall sets contain the full embedding and deembedding data so that they can be transferred to other instruments.

Remote command:

```
MMEMory:LOAD:VNETworks<Ch>:DIFFerential:EMBedding<LogPt>
```

6.13.2 Offset Tab

Defines length offset parameters for each port.

Use the complementary dock widget to activate or deactivate length/loss compensation for selected ports (see [Chapter 6.13.1.2, "Offset Panel"](#), on page 435).



The marker function [Zero Delay at Marker](#) function overwrites the offset parameters.



Background information

Refer to the following sections.

- [Chapter 5.6, "Offset Parameters and De-/Embedding"](#), on page 173
- [Chapter 5.6.1.1, "Definition of Offset Parameters"](#), on page 173
- [Chapter 5.6.1.3, "Auto Length"](#), on page 174
- [Chapter 5.6.1.6, "Application and Effect of Offset Parameters"](#), on page 178
- [Chapter 5.6.1.7, "Offset Parameters for Balanced Ports"](#), on page 179
- [Chapter 5.6.1.5, "Fixture Compensation"](#), on page 177

6.13.2.1 Controls on the Offset Tab

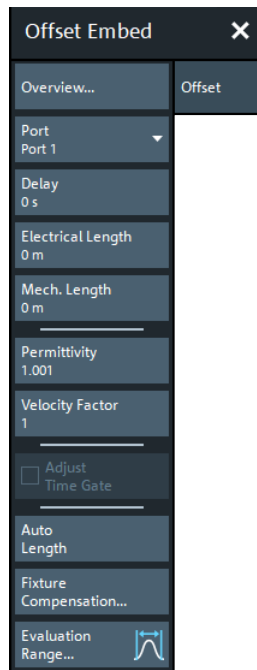

Overview

This button is available on all "Offset Embed" softtool tabs. It opens the [Overview Panel](#) in the [Offset Embed Dock Widget](#).

Port

Physical test port of the analyzer. You can define independent offset parameters for all ports.

Remote command:

The <PhyPt> numeric suffix in the [SENSe<Ch>:]CORRection:... commands identifies the physical port.

Delay / Electrical Length / Mech. Length

Defines the length offset at the selected port as a delay, an electrical length, or a mechanical length. The three quantities are related by:

$$Delay = \frac{L_{mech} \cdot \sqrt{\epsilon_r}}{c}; \quad Electrical\ Length = L_{mech} \cdot \sqrt{\epsilon_r}$$

and overwrite each other. See also [Chapter 5.6.1.1, "Definition of Offset Parameters"](#), on page 173.

Note: The entered parameters must correspond the actual (one-way) length of the transmission line. To account for the propagation in both directions, the phase shift of a reflection parameter due to a given length offset is twice the phase shift of a transmission parameter. For a numeric example, see [Chapter 5.6.1.6, "Application and Effect of Offset Parameters"](#), on page 178.

Remote command:

```
[SENSe<Ch>:]CORRection:EDELay<PhyPt>[:TIME]
[SENSe<Ch>:]CORRection:EDELay<PhyPt>:ELENgth
[SENSe<Ch>:]CORRection:EDELay<PhyPt>:DISTance
```

Permittivity / Velocity Factor

Defines the permittivity (ϵ_r) and velocity factor of the dielectric in the transmission line between the reference plane and the DUT. The velocity factor is $1/\sqrt{\epsilon_r}$ and is a measure for the velocity of light in a dielectric with permittivity ϵ_r relative to the velocity of light in the vacuum (velocity factor < 1). Permittivity and velocity factor are coupled parameters.

See also [Chapter 5.6.1.1, "Definition of Offset Parameters"](#), on page 173.

Remote command:

```
[SENSe<Ch>:]CORRection:EDELay<PhyPt>:DIElectric
```

Adjust Time Gate

Activates the operating mode where the time gate is moved in the opposite direction when the "Delay" setting (or any other length offset parameter) is changed. The button is available if a time gate is active (see ["Time Gate"](#) on page 284). In time domain, a positive delay shifts the time gate to the left, a negative delay shifts it to the right.

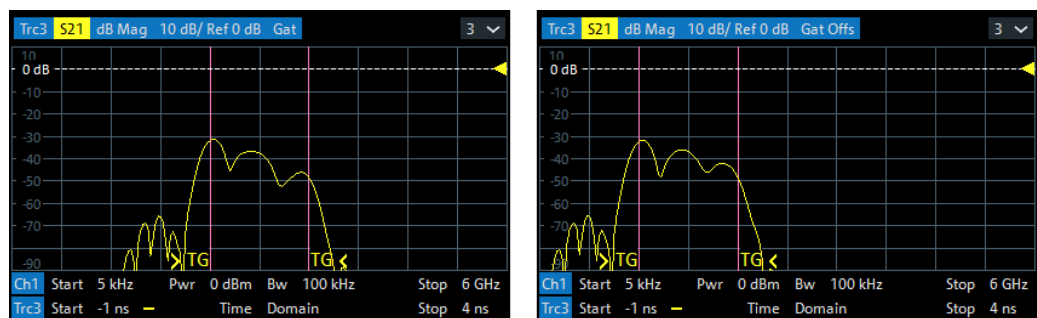

left = no delay
right = delay 1 ns

The position of the time gate is always relative to the end of the offset transmission line. As a consequence, "Adjust Time Gate" allows measurements at variable offset but fixed time gate position.

Example: The impedance of an antenna with possible faults is measured using a time gate and a variable length offset. If "Adjust Time Gate" is off, the time gate is at a constant distance from the offset-corrected reference plane (end of the offset transmission line). Its absolute position is varied along with the length offset.

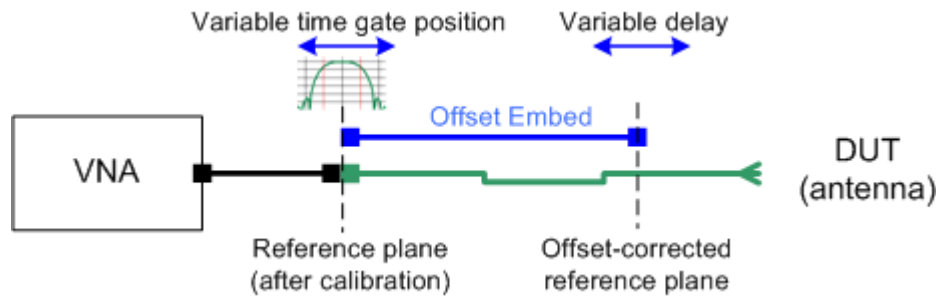

If "Adjust Time Gate" is on, the time gate is moved to left (right) when the offset-corrected reference plane is moved to the right (left). Its absolute position remains fixed. With this setting, it is possible, e.g., to keep the time gate at the position of the antenna connector while the antenna is measured at different length offsets.

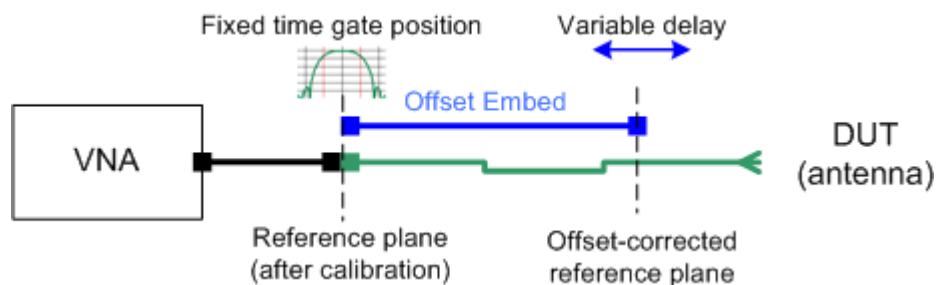

Remote command:

```
CALCulate:FILTer[:GATE]:TIME:AOFFset
```

Auto Length

Calculates the electrical length offset for the receive port of the active trace. See [Chapter 5.6.1.3, "Auto Length"](#), on page 174.

If "Delay" is the selected trace format, the entire trace is shifted in vertical direction and centered on zero. In phase format, the "Auto Length" corrected trace shows the deviation from linear phase.

Use [Evaluation Range...](#) to limit the frequency range for the calculation.

Note that in order to calculate the electrical length offset of port i , you have to select a trace that uses port i as one of its receive ports. It is **not** relevant for the "Auto Length" function which [Port](#) is selected.

If the measured quantity is a ratio, or if it is derived from a ratio, its receiving port is given as the index of the wave quantity in the numerator. If the active trace shows an S-parameter S_{ij} , then "Auto Length" adds a length offset at port i . If the receive port is balanced, then the same offset is applied to both its physical ports.

Remote command:

```
[SENSe<Ch>:]CORRection:EDELay:AUTO
```

Fixture Compensation...

The "Fixture Compensation..." button opens the [Fixture Compensation Dialog](#).

Evaluation Range...

The "Evaluation Range..." button opens the [Evaluation Range Dialog](#) that allows you to restrict the frequency range of auto length (and loss) calculations.

6.13.2.2 Fixture Compensation Dialog

This dialog allows you to correct the measurement result for the effects of a test fixture.

Access:

- CHANNEL – [OFFSET EMBED] > "Offset" > "Fixture Compensation..."
- CHANNEL – [OFFSET EMBED] > "One Way Loss" > "Fixture Compensation..."



Background Information

Refer to [Chapter 5.6.1.5, "Fixture Compensation"](#), on page 177.

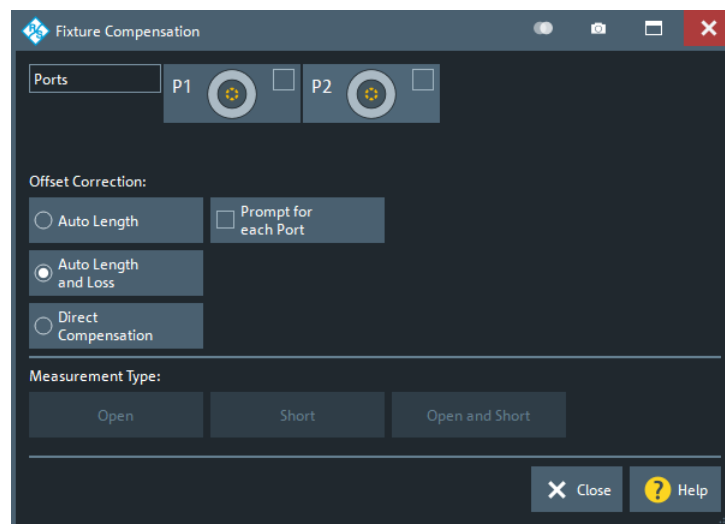

Ports

Selects the ports for whom fixture compensation data shall be acquired.

Note: For a unidirectional R&S ZND (see [Chapter 5.1.4.3, "R&S ZND: Unidirectional vs. Bidirectional Operation"](#), on page 75) port 2 cannot be used as source port and hence P2 is hidden in this dialog.

Auto Length / Auto Length and Loss

"Auto Length" or "Auto Length and Loss" implies that a global electrical length offset and loss is determined in analogy to the general offset compensation (see [Chapter 5.6.1.3, "Auto Length"](#), on page 174 and [Chapter 5.6.1.4, "Auto Length and Loss"](#), on page 176).

Remote command:

```
[SENSe:]CORRection:COLLect:FIXTure:LMPParameter:LOSS[:STATE]
```

Direct Compensation

With "Direct Compensation", a frequency-dependent transmission factor is calculated; see ["Auto Length and Loss vs. Direct Compensation"](#) on page 177.

Remote command:

```
[SENSe:]CORRection:COLLect:FIXTure:LMPParameter[:STATe]
[SENSe<Ch>:]CORRection:OFFSet<PhyPt>:DFComp[:STATe]?
```

Prompt for Each Port

Determines how the R&S ZND performs the sweeps for a given termination type (Open and/or Short; see ["Measurement Type"](#) on page 448).

- If unchecked, it performs the sweeps for Open/Short without interruption, implicitly assuming that **all** ports are terminated accordingly
- If checked, it interrupts the data acquisition process after each port, which allows you to modify the test setup (e.g. terminate the next measured port).

Measurement Type

The "Open", "Short", and "Open and Short" buttons bring up the ["Measure Fixture wizard"](#) dialog that guides you through the actual fixture measurement. See ["Open/Short vs. Open and Short compensation"](#) on page 178.

Measure Fixture wizard

The "Measure Fixture" dialog guides you through the previously configured fixture compensation measurements.

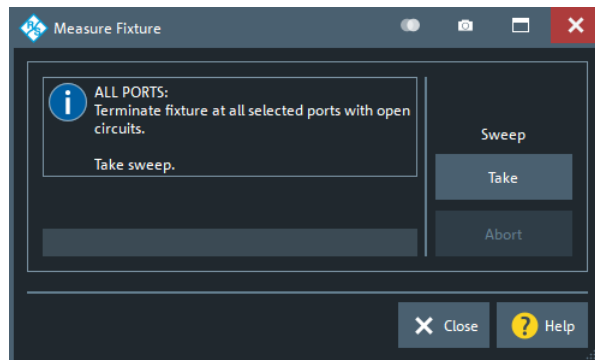
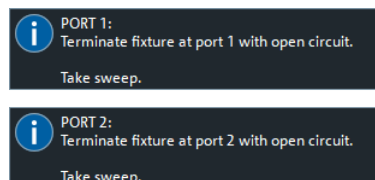

Figure 6-20: Measure Fixture dialog: Auto Length (and Loss)

To acquire the necessary data, proceed as indicated in the information area.

With Prompt for Each Port disabled, "Take" acquires data for all selected ports in one go. Otherwise sweeps are taken port by port.



For "Direct Compensation", it is also possible to save the acquired data to file. In future measurements, you can load these files instead of repeating the data acquisition.

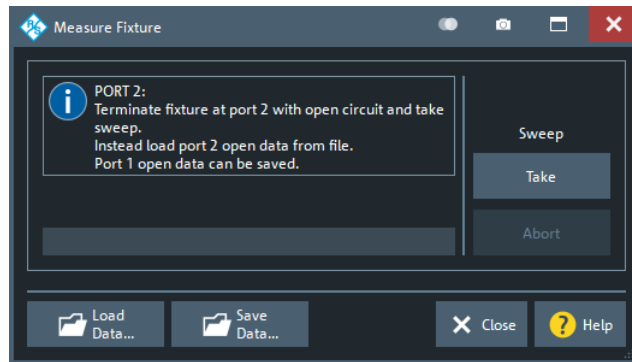

Figure 6-21: Measure Fixture dialog: Direct Compensation (and Prompt for Each Port)

"Direct Compensation" data files are standard trace files, containing reflection parameter traces for the related port and standard:

Table 6-3: Direct Compensation data

Prompt for Each Port	File Type	Description
disabled	csv	One csv trace file per standard, containing reflection traces for all selected ports; see Chapter 5.4.2.2, "ASCII (*.csv) Files" , on page 137
enabled	s1p	One 1-port Touchstone file per standard and port (see Chapter 5.4.2.1, "Touchstone Files" , on page 130)

Tip: Remote control provides additional flexibility. You can:

- Measure the same ports repeatedly without changing the standards and attribute the results to different channels.
- Calculate the compensation data for different ports, using mixed Open and Short standards.

Refer to the program example for `[SENSe<Ch>:]CORRection:COLLect:FIXTure[:ACQuire]`.

Remote command:

```
[SENSe<Ch>:]CORRection:COLLect:FIXTure:START
[SENSe<Ch>:]CORRection:COLLect:FIXTure[:ACQuire]
[SENSe<Ch>:]CORRection:COLLect:FIXTure:SAVE
[SENSe<Ch>:]CORRection:COLLect:FIXTure:EXPort
[SENSe<Ch>:]CORRection:COLLect:FIXTure:IMPort
```

6.13.3 One Way Loss Tab

Defines loss parameters for each physical port.

Use the complementary dock widget to activate or deactivate length/loss compensation for selected ports (see [Chapter 6.13.1.2, "Offset Panel"](#), on page 435).



Background information

Refer to the following sections.

- [Chapter 5.6, "Offset Parameters and De-/Embedding"](#), on page 173
- [Chapter 5.6.1.2, "Definition of Loss Parameters"](#), on page 174
- [Chapter 5.6.1.4, "Auto Length and Loss"](#), on page 176
- [Chapter 5.6.1.5, "Fixture Compensation"](#), on page 177

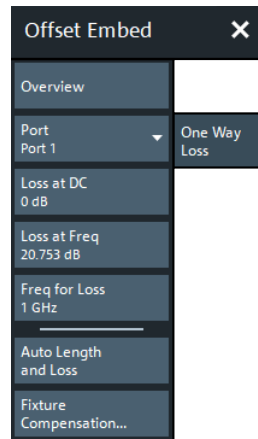

Overview

See ["Overview"](#) on page 444.

Port

Physical test port of the analyzer. You can define independent loss parameters for all ports.

Remote command:

The <PhyPt> numeric suffix in the [SENSe<Ch>:]CORRection:... commands identifies the physical port.

Loss at DC / Loss at 1st Freq / 1st Freq for Loss

See ["Loss at DC / Loss at 1st Freq / 1st Freq for Loss / Use 2nd Freq / Loss at 2nd Freq / 2nd Freq for Loss"](#) on page 435.

Auto Length and Loss

Determines the length offset and one-way loss parameters for the receive port of the active trace. See [Chapter 5.6.1.4, "Auto Length and Loss"](#), on page 176.

Use [Evaluation Range...](#) to limit the frequency range for the calculation.

Note:

- If "Auto Length and Loss" is used with a line connected to a test port, the end of the line should be left open.
- To calculate the electrical length offset and loss of port *i*, you have to select a trace that uses port *i* as one of its receive ports. It is **not** relevant for the "Auto Length and Loss" function which [Port](#) is selected.

If the measured quantity is a ratio, or if it is derived from a ratio, its receiving port is given as the index of the wave quantity in the numerator. If the active trace shows an S-parameter S_{ij} , then "Auto Length" adds a length offset at port i . If the receive port is balanced, then the same offset and length is applied to both its physical ports.

Remote command:

```
[SENSe<Ch>:]CORRection:LOSS:AUTO
```

Fixture Compensation...

The "Fixture Compensation..." button opens the [Fixture Compensation Dialog](#).

Evaluation Range...

The "Evaluation Range..." button opens the [Evaluation Range Dialog](#) that allows you to restrict the frequency range of auto length (and loss) calculations.

6.13.4 Single Ended Tab

Allows you to specify 2-port deembedding/embedding networks for each physical port.

Such a network is either defined:

- via its S-parameters stored in a two-port Touchstone file (*.s2p) or
- by selecting a predefined lumped element model and specifying the available parameters (resistances/conductances, capacitances, inductances)

See [Chapter 5.6.2.3, "Circuit Models for 2-Port Networks"](#), on page 181.

Use the complementary dock widget to activate or deactivate deembedding/embedding for selected ports (see [Chapter 6.13.1.3, "Single Ended Panel"](#), on page 437).



Background information

Refer to the section [Chapter 5.6.2.10, "Combining Several De-/Embedding Networks"](#), on page 189.

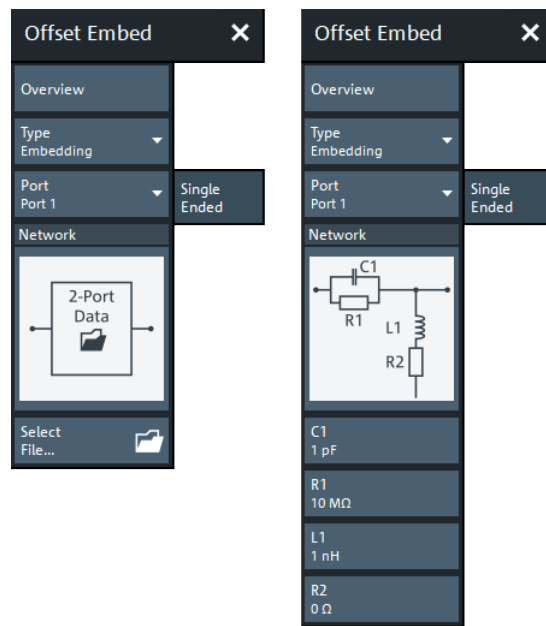

Figure 6-22: Offset Embed > Single Ended softtool

left = 2 port data file selected for deembedding

right = lumped element model selected for de-/embedding



If the "Fixture Simulator" is disabled for the related channel (see "Fixture Simulator" on page 429), this tab is inactive, i.e. all controls except the "Overview" button are grayed out.

Overview

See "Overview" on page 444.

Type

Switches between "Deembedding" and "Embedding" network definition.

Port

Physical port. The transformation networks are defined such that the analyzer is connected to the left of the circuit while the DUT is connected to the right side. You can define independent transformation networks for all ports.

Remote command:

The <PhyPt> numeric suffix in the embedding/deembedding commands identifies the physical port; see e.g. `CALCulate<Ch>:TRANSform:VNETworks:SENDED:DEEMbedding<PhyPt>[:STATe]` or `CALCulate<Ch>:TRANSform:VNETworks:SENDED:EMBedding<PhyPt>[:STATe]`.

All Deembedding Activated

Deactivates or activates all deembeddings (single-ended, balanced, port set, ground loop) for the active channel, if any.

This control is only visible if **Type** = "Deembedding".

Remote command:

n.a.

Network

The graphical list contains all available 2-port networks:

- The  symbol selects "no network" and disables single-ended de-/embedding.
- The "2-Port Data" network is defined by means of an s2p file (see [Select File...](#)). For deembedding, the s2p file can also be generated by a third-party fixture modeling tool (see ["Fixture Tool"](#) on page 454).
- The remaining networks are defined by lumped elements. Their parameters are displayed below the graphical list.

Tip: Drag and drop the network symbols in horizontal or vertical direction to switch to the next symbol. The lumped elements are numbered from top to bottom.

Remote command:

```
CALCulate<Ch>:TRANSform:VNETworks:SENDEd:DEEMbedding<PhyPt>[:
STATE]
CALCulate<Ch>:TRANSform:VNETworks:SENDEd:DEEMbedding<PhyPt>:
TNDefinition
CALCulate<Ch>:TRANSform:VNETworks:SENDEd:DEEMbedding<PhyPt>:
PARAMeters:C<Cmp>
CALCulate<Ch>:TRANSform:VNETworks:SENDEd:DEEMbedding<PhyPt>:
PARAMeters:G<Cmp>
CALCulate<Ch>:TRANSform:VNETworks:SENDEd:DEEMbedding<PhyPt>:
PARAMeters:L<Cmp>
CALCulate<Ch>:TRANSform:VNETworks:SENDEd:DEEMbedding<PhyPt>:
PARAMeters:R<Cmp>
CALCulate<Ch>:TRANSform:VNETworks:SENDEd:EMBedding<PhyPt>[:
STATE]
CALCulate<Ch>:TRANSform:VNETworks:SENDEd:EMBedding<PhyPt>:
TNDefinition
CALCulate<Ch>:TRANSform:VNETworks:SENDEd:EMBedding<PhyPt>:
PARAMeters:C<Cmp>
CALCulate<Ch>:TRANSform:VNETworks:SENDEd:EMBedding<PhyPt>:
PARAMeters:G<Cmp>
CALCulate<Ch>:TRANSform:VNETworks:SENDEd:EMBedding<PhyPt>:
PARAMeters:L<Cmp>
CALCulate<Ch>:TRANSform:VNETworks:SENDEd:EMBedding<PhyPt>:
PARAMeters:R<Cmp>
```

Select File...

"Select File..." is enabled as long as the "2-Port Data" network is selected. This network is defined by its S-parameters stored in a two-port Touchstone file (*.s2p). No additional parameters are required.

In case the port number conventions of the loaded two-port Touchstone file differ from network analyzer conventions (port 1 on the left, i.e. on the analyzer side; port 2 on the right, i.e. on the DUT side), it is possible to "Swap Gates". The analyzer will interchange the port numbers (e.g. $S_{12} \rightarrow S_{21}$) when loading the file.

Note: The loaded file is stored in the active recall set. Recall sets contain the full (de-)embedding data so that they can be transferred to other instruments.

Remote command:

```
MMEMory:LOAD:VNETworks<Ch>:SENDEd:DEEMbedding<PhyPt>
```

```
MMEMory:LOAD:VNETworks<Ch>:SENDEd:EMBedding<PhyPt>
```

Fixture Tool

The "Fixture Tool" section is only available for deembedding 2-port data networks.

Its controls allow you to select and run a third-party fixture modeling tool (see [Chapter 6.13.5, "Fixture Modeling Dialog"](#), on page 454) and to use its results for single-ended deembedding.

If the selected fixture modeling tool is not installed on the instrument, the "Run Tool" button is disabled/grayed out. Otherwise it opens the [Fixture Modeling Dialog](#) that guides you through the fixture modeling.

Use the "Info" button to get additional information about the selected tool. For background information, see [Chapter 5.6.2.9, "Fixture Modeling and Deembedding"](#), on page 187.

6.13.5 Fixture Modeling Dialog

Allows you to model a test fixture using the selected fixture modeling tool and to deembed selected ports using the generated touchstone files.



Background information

See [Chapter 5.6.2.9, "Fixture Modeling and Deembedding"](#), on page 187.

Access: CHANNEL – [OFFSET EMBED] > "Single Ended" / "Balanced" > "Run Tool"

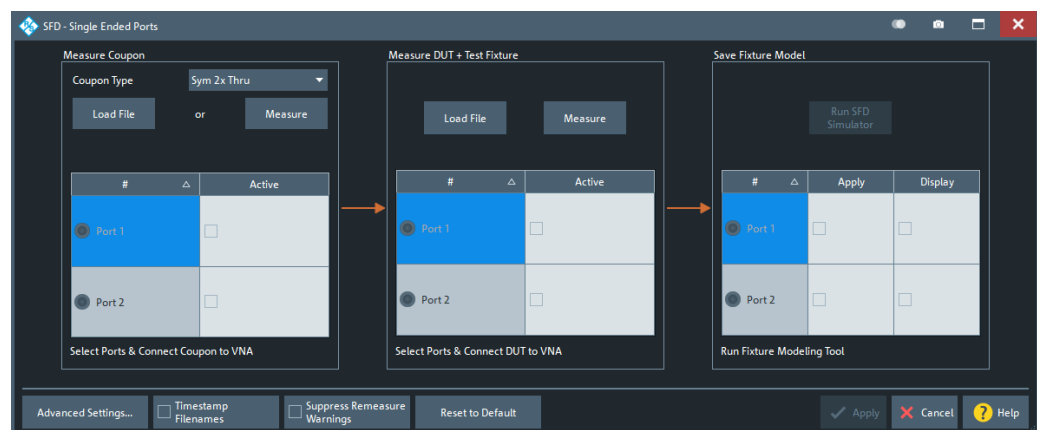

Figure 6-23: Fixture modeling dialog: SFD - Single Ended Ports

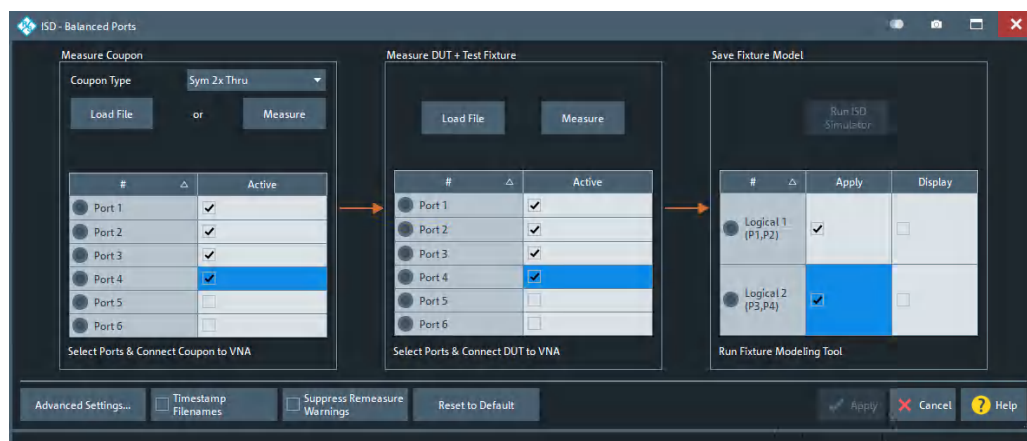

Figure 6-24: Fixture modeling dialog: ISD - Balanced Ports

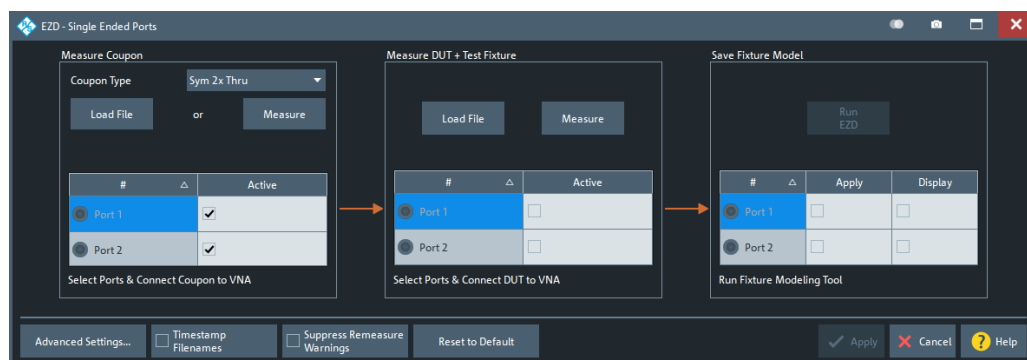

Figure 6-25: Fixture modeling dialog: EZD - Single Ended Ports

The fixture modeling proceeds in the following steps:

1. Measure one or more test coupons for the related fixture; see [Chapter 6.13.5.2, "Measure Coupon"](#), on page 457
The tools differ in the available coupon types.
2. Measure the DUT with the fixture; see [Chapter 6.13.5.3, "Measure DUT + Test Fixture"](#), on page 458
3. Run the selected tool to calculate the Touchstone files modeling the test fixture; see [Chapter 6.13.5.4, "Save Fixture Model"](#), on page 459.

The calculated s_{Np} file(s) can then be used to deembed the DUT at selected port(s).



All files generated by actions in this dialog are stored in the directory C:\Users\Public\Documents\Rohde-Schwarz\Vna\Embedding.



The current implementation assumes symmetrical lead-ins and lead-outs.

6.13.5.1 Common Controls on the Dialog

The following controls are located at the bottom of each dialog (ISD/SFD/EZD, single-ended/balanced):

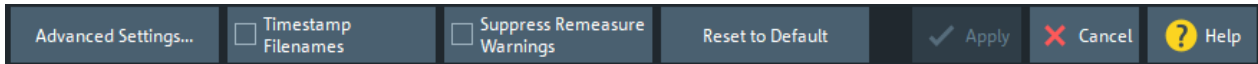

Advanced Settings ...

Opens the "Advanced Settings" dialog of the selected tool. See:

- [Chapter 6.13.5.6, "ISD Advanced Settings"](#), on page 461
- [Chapter 6.13.5.7, "SFD Advanced Settings"](#), on page 465
- [Chapter 6.13.5.8, "EZD Advanced Settings"](#), on page 466

Timestamp Filenames

If checked, the names of subsequently generated "Test Coupon" and "DUT + Test Fixture" files are prefixed with the current date and time.

Remote command:

`CALCulate:FMODEl:REName`

Suppress Remeasure Warnings

If checked, the [Measure Coupon](#) and [Measure DUT + Test Fixture](#) do not raise warnings, if the measurement is repeated with different ports.

Remote command:

n.a.

Reset to Default

Restores the default settings of the selected fixture modeling tool. This comprises:

- the states and settings in the [Measure Coupon](#), [Measure DUT + Test Fixture](#) and [Save Fixture Model](#) sections (common for all tools)
- the advanced settings of the selected tool (tool specific)

Remote command:

n.a.

Apply

This button is only active, if the selected deembedding tool has been successfully run (see [Chapter 6.13.5.4, "Save Fixture Model"](#), on page 459).

Applies the calculated deembedding files `<...>_left_DUT.sNp` and `<...>_right_DUT.sNp` to the ports marked "Active" in the [Save Fixture Model](#) section.

Remote command:

`MMEMory:LOAD:VNETworks<Ch>:SENDEd:DEEMbedding<PhyPt>`
`MMEMory:LOAD:VNETworks<Ch>:BALanced:DEEMbedding<LogPt>`

Cancel

Closes the dialog without applying any deembedding files.

6.13.5.2 Measure Coupon

The "Measure Coupon" section allows you to measure one or more test coupons for the related fixture.

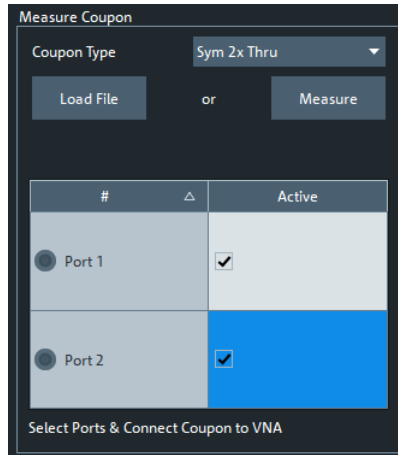

Coupon Type

Selects the coupon type to be measured. The following coupon types are supported:

	ISD	SFD	EZD
"Sym 2x Thru"	✓	✓	✓
"1x Open"	✓	✓	–
"1x Short"	✓	✓	–
"1x Open, 1x Short"	✓	–	–

Remote command:

```
CALCulate:FModel:ISD<Ph_pt>:COUPon:TYPE
```

```
CALCulate:FModel:SFD<Ph_pt>:COUPon:TYPE
```

Measure / Measure Open / Measure Short

Starts the coupon measurement at the **Active** ports.

The display area shows all the S parameter measurements being made. The resulting Touchstone file is written to C:\Users\Public\Documents\Rohde-Schwarz\Vna\Embedding.

For **Coupon Type** "1x Open, 1x Short" (ISD only) the measurement proceeds in two steps: one for the "1x Open" and one for the "1x Short" coupon. The label of the "Measure" button changes accordingly.

Remote command:

```
CALCulate:FModel:ISD<Ph_pt>:COUPon:MEASure
```

```
CALCulate:FModel:ISD<Ph_pt>:COUPon:MEASure:OPEN
```

```
CALCulate:FModel:ISD<Ph_pt>:COUPon:MEASure:SHORT
```

```
CALCulate:FModel:SFD<Ph_pt>:COUPon:MEASure
```

```
CALCulate:FModel:EZD<Ph_pt>:COUPon:MEASure on page 639
```

Load File / 1x Open Preset / 1x Short Preset

Allows you to load the coupon properties from a Touchstone file (*.s*p”).

Remote command:

```
CALCulate:FModel:ISD<Ph_pt>:COUPon:MEASure:FILEname
CALCulate:FModel:ISD<Ph_pt>:COUPon:MEASure:OPEN:FILEname
CALCulate:FModel:ISD<Ph_pt>:COUPon:MEASure:SHORT:FILEname
CALCulate:FModel:SFD<Ph_pt>:COUPon:MEASure:FILEname
CALCulate:FModel:EZD<Ph_pt>:COUPon:MEASure:FILEname
```

Active

Before starting to [measure](#) the test coupon, use these checkboxes to indicate the physical ports to which it is connected.

Table 6-4: Allowed numbers of active ports

	"Sym 2x Thru"	"1x Open, 1x Short"	other
Single-ended	2	1 or 2	1
Balanced	2 or 4	2 or 4	2

Remote command:

```
CALCulate:FModel:ISD<Ph_pt>:COUPon[:STATe]
CALCulate:FModel:SFD<Ph_pt>:COUPon[:STATe]
CALCulate:FModel:EZD<Ph_pt>:COUPon[:STATe]
```

6.13.5.3 Measure DUT + Test Fixture

The "Measure DUT + Test Fixture" section allows you to measure the whole structure, i.e. the DUT with the test fixture.



For EZD this section is only available if [impedance correction](#) is enabled in the "Advanced Settings".

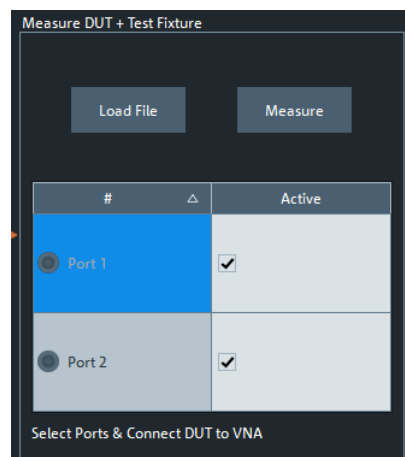

Load File

Load DUT + test fixture data from file

Remote command:

```
CALCulate:FModel:EZD<Ph_pt>:DUT:MEASure:FiLename
CALCulate:FModel:ISD<Ph_pt>:DUT:MEASure:FiLename
CALCulate:FModel:SFD<Ph_pt>:DUT:MEASure:FiLename
```

Measure

Starts the measurement of DUT + test fixture at the **Active** ports.

The display area shows all the S parameter measurements being made. The resulting Touchstone file is written to C:\Users\Public\Documents\Rohde-Schwarz\Vna\Embedding.

Remote command:

```
CALCulate:FModel:EZD<Ph_pt>:DUT:MEASure
CALCulate:FModel:ISD<Ph_pt>:DUT:MEASure
CALCulate:FModel:SFD<Ph_pt>:DUT:MEASure
```

Active

Before starting to **Measure**, use these checkboxes to indicate the physical ports to which DUT + test fixture are connected. For single-ended deembedding, 2 ports must be active, for balanced deembedding 4 ports.

Remote command:

```
CALCulate:FModel:EZD<Ph_pt>:DUT[:STATe]
CALCulate:FModel:ISD<Ph_pt>:DUT[:STATe]
CALCulate:FModel:SFD<Ph_pt>:DUT[:STATe]
```

6.13.5.4 Save Fixture Model

This section allows you to run the selected deembedding tool to generate the Touchstone files for fixture deembedding (and the Touchstone file of the de-embedded DUT).



Figure 6-26: Save Fixture Model section

left = single-ended
right = balanced

Run <Fixture Modeling Tool>

Runs the selected fixture deembedding tool.

This button is only active, if both:

- the test coupon measurement finished successfully or the test coupon data were successfully loaded from file (see [Chapter 6.13.5.2, "Measure Coupon"](#), on page 457)
- the measurement of DUT + test fixture finished successfully (see [Chapter 6.13.5.3, "Measure DUT + Test Fixture"](#), on page 458)

The resulting Touchstone files (S parameters of the lead-ins, the lead-outs, and the de-embedded DUT) are written to C:\Users\Public\Documents\Rohde-Schwarz\Vna\Embedding. If result files with the same names already exist, you can decide whether you want to rename or overwrite them.

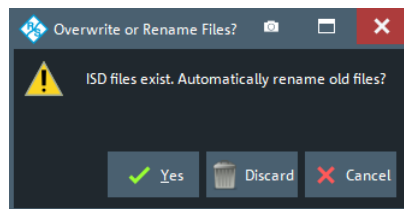

If running the deembedding tool causes errors, the [<Deembedding Tool> Errors Dialog](#) provides additional information.

Note: For ISD first a batch task file `Embeddingconfig_znb.abt` is created and then the tool is run in batch mode (see the ISD User Guide).

Remote command:

```
CALCulate:FMODe1:ISD<Ph_pt>:RUN:RUN
```

```
CALCulate:FMODe1:SFD<Ph_pt>:RUN:RUN
```

```
CALCulate:FMODe1:EZD<Ph_pt>:RUN:RUN
```

Apply

Use these checkboxes to indicate the ports (physical for single-ended deembedding, logical for balanced deembedding) to which the deembedding files (generated by [Run <Fixture Modeling Tool>](#)) shall be assigned when the dialog is closed using [Apply](#).

Note: For a "left" deembedding file the original port order is used, for a "right" deembedding files the swap gates (ports) function is used.

Remote command:

```
CALCulate:FMODe1:ISD<Ph_pt>:RUN[:STATe]
```

```
CALCulate:FMODe1:SFD<Ph_pt>:RUN[:STATe]
```

```
CALCulate:FMODe1:EZD<Ph_pt>:RUN[:STATe]
```

Display

Select "Display" to display some or all the S parameter traces of the generated touchstone file that are applied for deembedding. A dialog then allows you to select the S parameter traces to be imported to new memory traces:

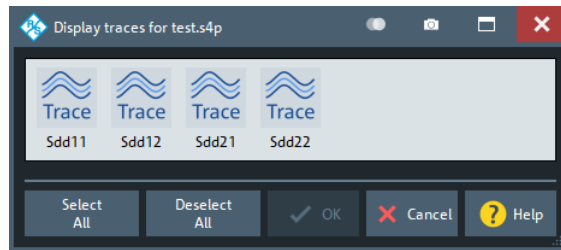

6.13.5.5 <Deembedding Tool> Errors Dialog

If running the related deembedding tool causes errors, a dialog provides additional information:

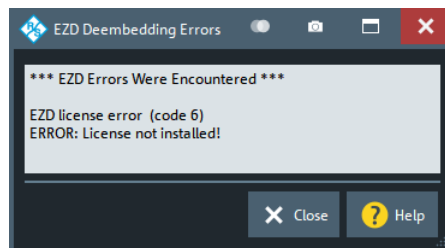

Figure 6-27: EZD error messages

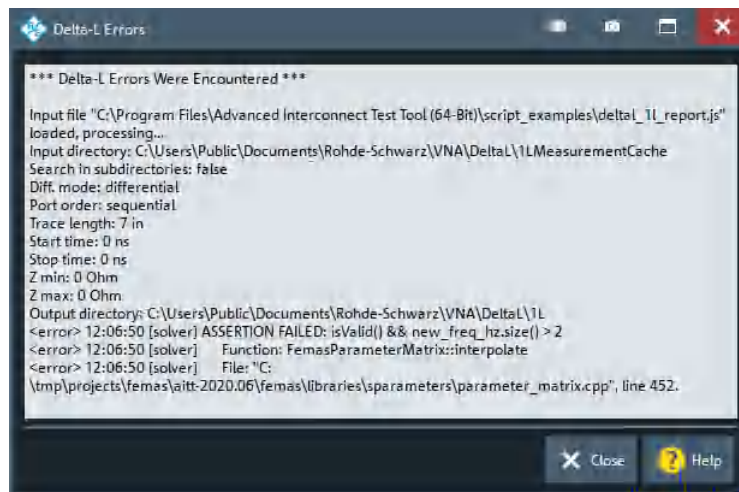
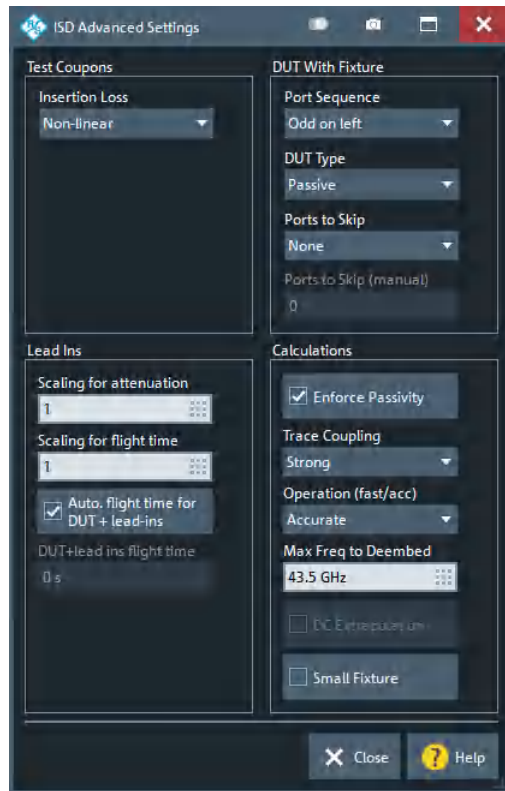

Figure 6-28: Delta-L error messages

6.13.5.6 ISD Advanced Settings

For details, see the ISD User Guide.



Test Coupons > Insertion Loss

Tells the ISD tool about the linearity of the 2xThru test coupon:

- "Linear": linear insertion loss
- "Non-Linear" (default): non-linear insertion loss
- "Resonant": the 2x Thru test coupon is split and used directly for deembedding. This option can be more accurate if the fixture and the 2x Thru have the same impedance at every location.

Remote command:

[CALCulate:FMODEl:ISD<Ph_pt>:ATTenuation:BEHavior](#) on page 616

Lead Ins

Defines how the ISD tool interprets the lead-in data.

Scaling for Lead In Atten ← Lead Ins

Scales the test coupon's attenuation.

Default is 1.

Remote command:

[CALCulate:FMODEl:ISD<Ph_pt>:SCALE:ATTenuation](#) on page 623

Scaling for Flt Tm ← Lead Ins

Overrides the lead-in's flight time (i.e. its delay) in case the through-trace test coupon is a bit too short or too long.

Default is 1.

Remote command:

```
CALCulate:FModel:ISD<Ph_pt>:SCALE:FTIME
```

Automatic Flt Tm for DUT + Lead Ins ← Lead Ins

If checked (default) the flight time for DUT + lead-ins is calculated automatically. Otherwise it can be specified (see "[Flt Tm for DUT + Lead Ins](#)" on page 463).

Remote command:

```
CALCulate:FModel:ISD<Ph_pt>:FTIME:OVERRIDE
```

Flt Tm for DUT + Lead Ins ← Lead Ins

If [Automatic Flt Tm for DUT + Lead Ins](#) is disabled, this allows you to set the flight time for DUT + Lead-ins manually.

This should be used if the "DUT + Test Fixture" does not have a Through response and the total flight time exceeds 10ns.

Remote command:

```
CALCulate:FModel:ISD<Ph_pt>:FTIME:DUT
```

DUT With Fixture

Defines how the ISD tool interprets the "DUT + Test Fixture" data.

Port Sequence ← DUT With Fixture

Tells the ISD tool about the arrangement of "DUT + Fixture" ports:

- "1 to N on left": ports 1 to N are on the left and ports N+1 to 2*N are on the right.
- "Odd on left" (default): 1, 3, 5, etc. are on the left and ports 2, 4, 6, etc. are on the right.
- "All on left": all ports are on the left

Note: Ports on the left/right are assumed to be coupled (if [Trace Coupling](#) is not set to "None". A port on the left side is not considered to be coupled to a port on the right side.

Remote command:

```
CALCulate:FModel:ISD<Ph_pt>:PORT:ORDER
```

DUT Type ← DUT With Fixture

Select "Passive"/"Active" if the DUT is passive/active.

Default is "Passive".

Remote command:

```
CALCulate:FModel:ISD<Ph_pt>:DUT:TYPE
```

Ports to Skip ← DUT With Fixture

Tells the ISD tool which ports (in the measured "DUT + Test Fixture" file) to skip when the tool is run.

- "None" (default): do not skip any ports
- "Ports on left": skip the ports on the left (according to the selected [Port Sequence](#))
- "Ports on right": skip the ports on the right (according to the selected port sequence)
- "Manually set ports": use [Ports to Skip \(manual\)](#) to define the ports to be skipped

Remote command:

```
CALCulate:FModel:ISD<Ph_pt>:PORT:SKIP:NONE
CALCulate:FModel:ISD<Ph_pt>:PORT:SKIP:LEFT
CALCulate:FModel:ISD<Ph_pt>:PORT:SKIP:RIGHT
```

Ports to Skip (manual) ← DUT With Fixture

If [Ports to Skip](#) is set to "Manually set ports", this text field allows you to define the ports to be skipped. Enter the port numbers, separated by blanks (e.g. '1 3 4').

Remote command:

```
CALCulate:FModel:ISD<Ph_pt>:PORT:SKIP
```

Calculations

Some additional parameters that define how the ISD tool calculates its output.

Enforce Passivity ← Calculations

If checked (default), the ISD tool enforces passivity and reciprocity for the test coupons and the test fixture.

Remote command:

```
CALCulate:FModel:ISD<Ph_pt>:PASSivity
```

Trace Coupling ← Calculations

Tells the ISD tool about coupling among lead-in traces

- "None": no coupling.
The ISD tool optimizes odd- and single-ended insertion losses.
- "Weak": coupling is extracted even if there are 2 ports enabled on the test coupon
- "Strong" (default): if the test coupon is a 4-port file, and there are two ports to be extracted, the ISD tool optimizes odd- and even-mode insertion losses.
The ISD tool automatically reverts to "Weak" if these conditions are not met.

Remote command:

```
CALCulate:FModel:ISD<Ph_pt>:TRACe:COUPling
```

Operation (fast/acc) ← Calculations

Influences the speed of execution and accuracy of the ISD tool.

- "Accurate" (default): normal execution mode
- "Fast": reduces the execution time to ~50%
Often this mode can be enabled with only little loss of accuracy.

Remote command:

```
CALCulate:FModel:ISD<Ph_pt>:OPERation
```

Max Freq to Deembed ← Calculations

When the test coupon's return loss is not less than the insertion loss, the maximum frequency to deembed together with the proper [Insertion Loss](#) setting gives the best accuracy.

By default, the maximum frequency is set to the maximum frequency the VNA can use.

Remote command:

```
CALCulate:FModel:ISD<Ph_pt>:SCALE:FREQuency
```

DC Extrapolation ← Calculations

This setting is only active, if a recent version of the ISD tool (from 2019-12 or later) is used.

If unchecked (default), the touchstone data of the generated deembedding file reach down to the start frequency of the instrument sweep. If checked, the ISD tool adds (extrapolated) S-parameter data for $f = 0$.

Remote command:

```
CALCulate:FModel:ISD<Ph_pt>:DCExtrapolat
```

Small Fixture ← Calculations

Enables/disables the ISD tool's small fixture mode.

Remote command:

```
CALCulate:FModel:ISD<Ph_pt>:SMALLfixture
```

6.13.5.7 SFD Advanced Settings

Allows you to specify advanced parameters for the SFD tool.

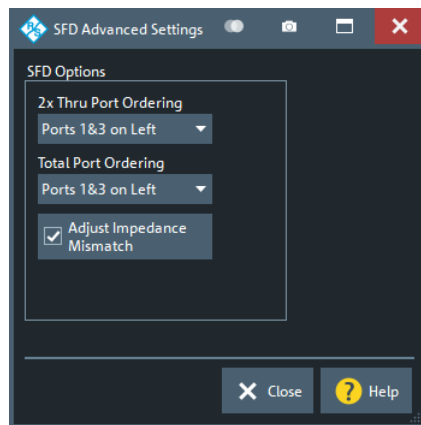
**2x Thru Port Ordering**

Tells the SFD tool about the port ordering of the 2x Thru test coupon

- "Ports 1&3 on Left" (default): odd ports are on the left and even ports are on the right
- "Ports 1&2 on Left" ports 1 to N are on the left and ports N+1 to 2·N are on the right

Remote command:

```
CALCulate:FModel:SFD<Ph_pt>:DIFFcfg
```

Total Port Ordering

Tells the SFD tool about the port ordering of the test fixture

- "Ports 1&3 on Left" (default): odd ports are on the left and even ports are on the right
- "Ports 1&2 on Left" ports 1 to N are on the left and ports N+1 to 2·N are on the right

Remote command:

`CALCulate:FMODEl:SFD<Ph_pt>:TOTaldiffcfg`

Adjust Impedance Mismatch

If checked, the SFD tool performs automatic impedance adjustments.

Remote command:

`CALCulate:FMODEl:SFD<Ph_pt>:AUTO` on page 625

6.13.5.8 EZD Advanced Settings

Allows you to specify advanced parameters for the EZD tool.

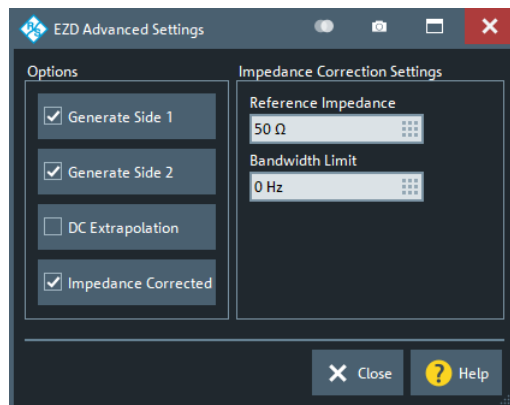

Generate Side 1/Generate Side2

If checked (default), the tool generates the deembedding file for side 1 / side 2.

Remote command:

`CALCulate:FMODEl:EZD<Ph_pt>:GENerate:SIDE<1|2>`

DC Extrapolation

If unchecked (default), the touchstone data of the generated deembedding file reach down to the start frequency of the instrument sweep. If checked, the EZD tool adds (extrapolated) S-parameter data for $f = 0$.

Remote command:

`CALCulate:FMODEl:EZD<Ph_pt>:DCEXtrapolat`

Impedance Corrected/Impedance Correction Settings

Disables/enables impedance correction and provides related settings.

Remote command:

`CALCulate:FMODEl:EZD<Ph_pt>:IMPedance` on page 641

`CALCulate:FMODEl:EZD<Ph_pt>:IMPedance:REFerence` on page 641

`CALCulate:FMODEl:EZD<Ph_pt>:IMPedance:BWIDlimit` on page 641

6.13.6 Port Sets Tab

Selects transformation networks for deembedding/embedding arbitrary port sets, defines their parameters, assigns them to a port set and enables embedding.

Use the complementary dock widget to create the required port sets and to activate or deactivate deembedding/embedding for selected port sets (see [Chapter 6.13.1.4, "Port Sets Panel"](#), on page 437).



Background information

Refer to [Chapter 5.6.2.5, "Port Pair De-/Embedding"](#), on page 184 and [Chapter 5.6.2.6, "Port Set De-/Embedding"](#), on page 184.

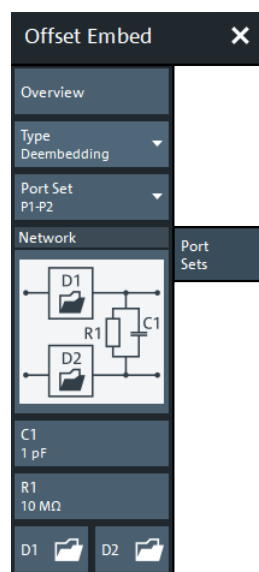

If the "Fixture Simulator" is disabled for the related channel (see ["Fixture Simulator"](#) on page 429), this tab is inactive, i.e. all controls except the "Overview" button are grayed out.

Overview

See ["Overview"](#) on page 444.

Type

Switches between "Deembedding" and "Embedding" network definition.

Port Set

Port sets, defined in the complementary [Port Sets Panel](#) dock widget panel. The transformation networks are defined such that the physical analyzer test ports are connected to the left of the circuit; the DUT ports are on the right side. You can define independent transformation networks for all port sets.

The port set number, i.e. the number at the beginning of each "Port Set" item, corresponds to the position of the port set in the [Port Sets Panel](#).

Remote command:

The port set number corresponds to the <ListId> numeric suffix in the port set de-/embedding commands; see e.g. `CALCulate<Ch>:TRANSform:VNETworks:PPAir:DEEMbedding<ListId>[:STATe]`.

All Deembedding Activated

Deactivates or activates all deembeddings (single-ended, balanced, port set, ground loop) for the active channel, if any.

This control is only visible if **Type** = "Deembedding".

Network

The 4-port deembedding/embedding network can either be defined via lumped element models (in combination with `s2p` Touchstone files) or via an `s4p` Touchstone file (see [Chapter 5.6.2.5, "Port Pair De-/Embedding"](#), on page 184). For networks (partly) defined by lumped elements, the lumped element parameters are displayed below the graphical network list. See [Chapter 5.6.2.4, "Circuit Models for 4-Port Networks"](#), on page 182.

The symbol selects "no network" and disables de-/embedding for the selected port set. The "D1" and "D2" networks are defined by imported S-parameter data; see [D1](#), [D2](#).

Tip:

- Drag and drop the network symbols in horizontal or vertical direction to switch to the next symbol. The lumped elements and S-parameter networks ("D1", "D2") are numbered from top to bottom.
- Use the [Conductance in Embedding Networks](#) switch to change from resistances in "Capacitor in parallel with resistor" circuit blocks to conductances and vice versa.

Remote command:

```
CALCulate<Ch>:TRANSform:VNETworks:PPAir:DEEMbedding<ListId>:
TNDefinition
CALCulate<Ch>:TRANSform:VNETworks:PPAir:DEEMbedding<ListId>:
PARAMeters:C<1|2|3>
CALCulate<Ch>:TRANSform:VNETworks:PPAir:DEEMbedding<ListId>:
PARAMeters:L<1|2|3>
CALCulate<Ch>:TRANSform:VNETworks:PPAir:DEEMbedding<ListId>:
PARAMeters:R<1|2|3>
CALCulate<Ch>:TRANSform:VNETworks:PPAir:DEEMbedding<ListId>:
PARAMeters:G<1|2|3>
CALCulate<Ch>:TRANSform:VNETworks:PPAir:EMBedding<ListId>:
TNDefinition
CALCulate<Ch>:TRANSform:VNETworks:PPAir:EMBedding<ListId>:
PARAMeters:C<1|2|3>
CALCulate<Ch>:TRANSform:VNETworks:PPAir:EMBedding<ListId>:
PARAMeters:L<1|2|3>
CALCulate<Ch>:TRANSform:VNETworks:PPAir:EMBedding<ListId>:
PARAMeters:R<1|2|3>
CALCulate<Ch>:TRANSform:VNETworks:PPAir:EMBedding<ListId>:
PARAMeters:G<1|2|3>
```

D1, D2

The "D1" (and "D2") buttons are enabled as long as the selected deembedding/embedding network is defined using Touchstone files.

When loading a touchstone file, the analyzer by default assumes odd ports left (VNA side), even ports right (DUT side). However, it is also possible to instruct the analyzer to assume an "Increasing Port Sequence", i.e. that the low port numbers are on the VNA side. Furthermore it is possible to "Swap Gates", i.e. to instruct the analyzer to swap the VNA and DUT side.

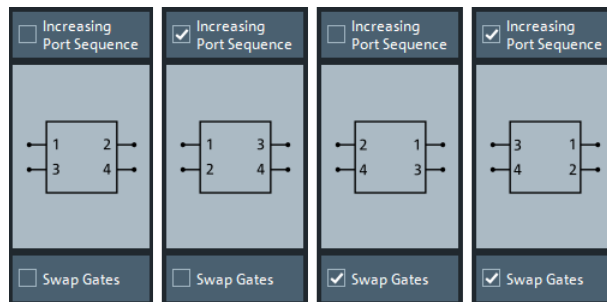

Note: The loaded file is stored in the active recall set. Persisted recall sets contain the full de-/embedding data so that they can be transferred to other instruments.

Remote command:

```
MMEMory:LOAD:VNETworks<Ch>:PPAir:DEEMbedding<ListId>
MMEMory:LOAD:VNETworks<Ch>:PPAir:EMBedding<ListId>
```

6.13.7 Balanced Tab

Selects 4-port transformation networks for balanced port deembedding/embedding, defines their parameters, assigns them to a balanced port and enables embedding.

Use the complementary dock widget to create [Balanced Panel](#) and to activate or deactivate deembedding/embedding for selected balanced ports (see [Chapter 6.13.1.5, "Balanced Panel"](#), on page 439).

**Background information**

Refer to the section [Chapter 5.6.2.10, "Combining Several De-/Embedding Networks"](#), on page 189.

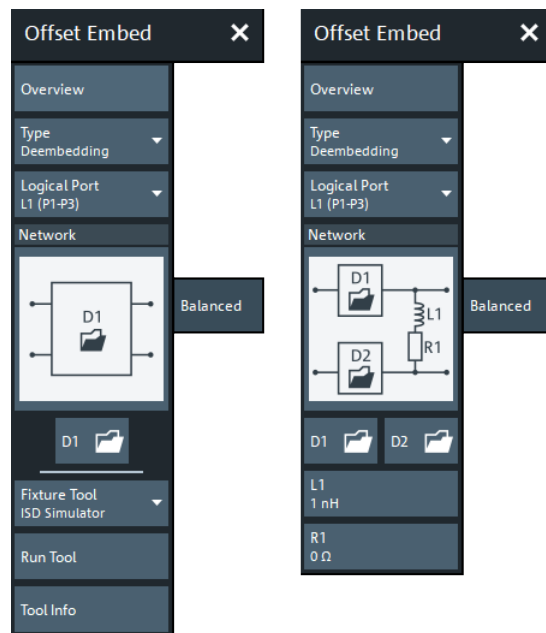

Figure 6-29: Offset Embed > Balanced softtool

left = 4 port data file selected for de-/embedding
 right = other network selected for de-/embedding



If the "Fixture Simulator" is disabled for the related channel (see "Fixture Simulator" on page 429), this tab is inactive, i.e. all controls except the "Overview" button are grayed out.

Overview

See "Overview" on page 444.

Type

Switches between "Deembedding" and "Embedding" network definition.

Logical Port

Logical analyzer port, as defined in the "Balanced Ports" configuration. The transformation networks are defined such that the physical analyzer test ports are connected to the left of the circuit; the DUT ports are on the right side.

Remote command:

The <LogPt> numeric suffix in the embedding/deembedding commands identifies the logical port; see e.g. `CALCulate<Ch>:TRANSform:VNETworks:BALanced:EMBedding<LogPt>[:STATe]`.

All Deembedding Activated

Deactivates or activates all deembeddings (single-ended, balanced, port set, ground loop) for the active channel, if any.

This control is only visible if **Type** = "Deembedding".

Remote command:

n.a.

Network

The graphical list contains all available 4-port networks (see [Chapter 5.6.2.4, "Circuit Models for 4-Port Networks"](#), on page 182).

The symbol selects "no network" and disables deembedding/embedding for the selected balanced port.

The 4-port data network (symbol "D1" only) is defined by means of an s4p file (see [D1, D2](#)). For deembedding, the s4p file can also be generated by a third-party fixture modeling tool (see ["Fixture Tool"](#) on page 454).

Other 2-port data-subnetworks (symbols "D1" and "D2") are defined by means of s2p files (see [Network](#)).

The parameters of lumped elements are displayed below the graphical list.

Tip:

- Drag and drop the network symbols in horizontal or vertical direction to switch to the next symbol. The lumped elements and S-parameter networks ("D1", "D2") are numbered from top to bottom.
- Use the [Conductance in Embedding Networks](#) switch to change from resistances in "Capacitor in parallel with resistor" circuit blocks to conductances and vice versa.

Remote command:

```
CALCulate<Ch>:TRANSform:VNETworks:BALanced:DEEMbedding<LogPt>:
TNDefinition
CALCulate<Ch>:TRANSform:VNETworks:BALanced:DEEMbedding<LogPt>:
PARAMeters:C<Cmp>
CALCulate<Ch>:TRANSform:VNETworks:BALanced:DEEMbedding<LogPt>:
PARAMeters:L<Cmp>
CALCulate<Ch>:TRANSform:VNETworks:BALanced:DEEMbedding<LogPt>:
PARAMeters:R<Cmp>
CALCulate<Ch>:TRANSform:VNETworks:BALanced:DEEMbedding<LogPt>:
PARAMeters:G<Cmp>
CALCulate<Ch>:TRANSform:VNETworks:BALanced:EMBedding<LogPt>:
TNDefinition
CALCulate<Ch>:TRANSform:VNETworks:BALanced:EMBedding<LogPt>:
PARAMeters:C<Cmp>
CALCulate<Ch>:TRANSform:VNETworks:BALanced:EMBedding<LogPt>:
PARAMeters:L<Cmp>
CALCulate<Ch>:TRANSform:VNETworks:BALanced:EMBedding<LogPt>:
PARAMeters:R<Cmp>
CALCulate<Ch>:TRANSform:VNETworks:BALanced:EMBedding<LogPt>:
PARAMeters:G<Cmp>
```

D1, D2

The "D1" and "D2" buttons are enabled as long as the selected [Network](#) comprises subnetworks that are defined via two-port or four-port Touchstone files (*.s2p, *.s4p).

When loading a touchstone file, the analyzer by default assumes odd ports left (VNA side), even ports right (DUT side). However, it is also possible to instruct the analyzer to assume an "Increasing Port Sequence", i.e. that the low port numbers are on the VNA side. Furthermore it is possible to "Swap Gates", i.e. to instruct the analyzer to swap the VNA and DUT side.

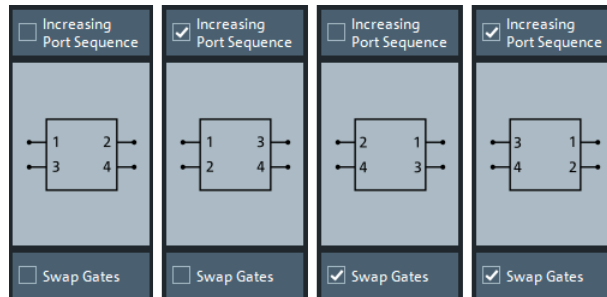

Note: The loaded file is stored in the active recall set. Persisted recall sets contain the full (de-)embedding data so that they can be transferred to other instruments.

Remote command:

```
MMEMory:LOAD:VNETworks<Ch>:BALanced:DEEMbedding<LogPt>
```

```
MMEMory:LOAD:VNETworks<Ch>:BALanced:EMBedding<LogPt>
```

6.13.8 Ground Loop Tab

Allows you to specify a 1-port ground loop deembedding/embedding network.

Such a network is either defined

- via its S-parameter stored in a one-port Touchstone file (*.s1p) or
- by selecting a predefined lumped element model (Shunt L or Shunt C) and specifying the available parameters (resistance/inductance or resistance/capacitance)

Use the complementary dock widget to activate or deactivate ground loop deembedding and embedding (see [Chapter 6.13.1.6, "Ground Loop Panel"](#), on page 441).



Background information

Refer to [Chapter 5.6.2.7, "Ground Loop De-/Embedding"](#), on page 186.

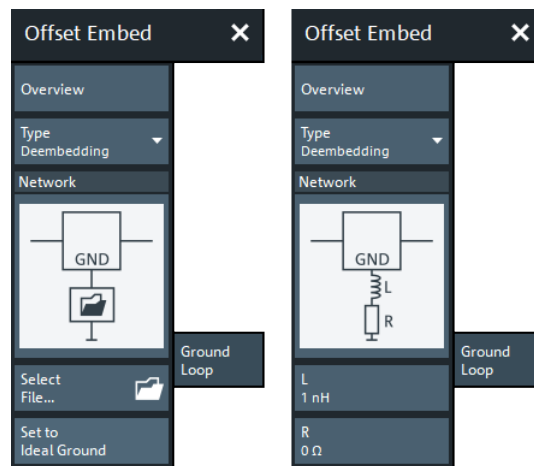

If the "Fixture Simulator" is disabled for the related channel (see "Fixture Simulator" on page 429), this tab is inactive, i.e. all controls except the "Overview" button are grayed out.

Overview

See "Overview" on page 444.

Type

Switches between "Deembedding" and "Embedding" network definition.

All Deembedding Activated

Deactivates or activates all deembeddings (single-ended, balanced, port set, ground loop) for the active channel, if any.

This control is only visible if **Type** = "Deembedding".

Network

The graphical list contains all available 1-port networks:

The symbol selects "no network" and disables ground loop de-/embedding.

The "1-Port Data" network is defined by imported S-parameter data; see [Select File...](#)

The remaining networks (Shunt L and Shunt C) are defined by lumped elements whose parameters are displayed below the graphical list.

Tip:

- Drag and drop the network symbols in horizontal or vertical direction to switch to the next symbol.
- Use the [Conductance in Embedding Networks](#) switch to change from resistances in "Capacitor in parallel with resistor" model to conductances and vice versa.

Remote command:

```
CALCulate<Ch>:TRANSform:VNETworks:GLOop:DEEMbedding:TNDefinition
CALCulate<Ch>:TRANSform:VNETworks:GLOop:DEEMbedding:PARAMeters:C
CALCulate<Ch>:TRANSform:VNETworks:GLOop:DEEMbedding:PARAMeters:L
CALCulate<Ch>:TRANSform:VNETworks:GLOop:DEEMbedding:PARAMeters:R
CALCulate<Ch>:TRANSform:VNETworks:GLOop:DEEMbedding:PARAMeters:G
```

```

CALCulate<Ch>:TRANSform:VNETworks:GLOop:EMBedding:TNDefinition
CALCulate<Ch>:TRANSform:VNETworks:GLOop:EMBedding:PARAMeters:C
CALCulate<Ch>:TRANSform:VNETworks:GLOop:EMBedding:PARAMeters:L
CALCulate<Ch>:TRANSform:VNETworks:GLOop:EMBedding:PARAMeters:R
CALCulate<Ch>:TRANSform:VNETworks:GLOop:EMBedding:PARAMeters:G

```

Select File...

"Select File..." is enabled as long as the "1-Port Data" network is selected. This network is defined by its S-parameters stored in a one-port Touchstone file (*.s1p). No additional parameters are required.

Note: The loaded file is stored in the active recall set. Persisted recall sets contain the full (de-)embedding data so that they can be transferred to other instruments.

Remote command:

```

MMEMory:LOAD:VNETworks<Ch>:GLOop:DEEMbedding
MMEMory:LOAD:VNETworks<Ch>:GLOop:EMBedding<group>

```

Set to Ideal Ground

This function is enabled as long as the 1-Port Data network is active. An imported S-parameter set is replaced by the S-parameters of an ideal through connection, which eliminates the transformation network.

6.13.9 Differential Match Tab

Allows you to specify a 2-port embedding network for the differential mode of a balanced port.

Such a network is either defined

- via its S-parameter stored in a two-port Touchstone file (*.s2p) or
- by specifying the parameters of a "Shunt L, Shunt C" lumped element model

Use the complementary dock widget to access the balanced port configuration and to activate or deactivate "Differential Match" embedding for selected balanced ports (see [Chapter 6.13.1.8, "Differential Match Panel"](#), on page 442).



Background information

Refer to [Chapter 5.6.2.8, "Differential Match Embedding"](#), on page 186.

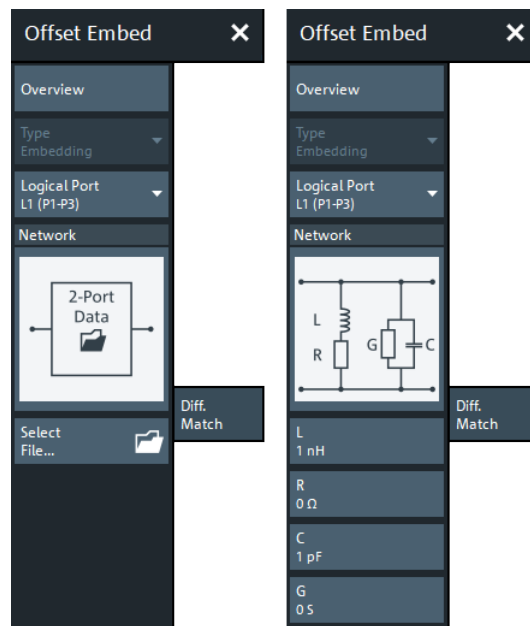

If the "Fixture Simulator" is disabled for the related channel (see ["Fixture Simulator"](#) on page 429), this tab is inactive, i.e. all controls except the "Overview" button are grayed out.

Overview

See ["Overview"](#) on page 444.

Type

Currently only Differential Match"Embedding" is supported.

Logical Port

Logical analyzer port, as defined in the "Balanced Ports" configuration. The transformation networks are defined such that the physical analyzer test ports are connected to the left of the circuit; the DUT ports are on the right side. You can define independent embedding networks for all balanced ports.

Remote command:

The <LogPt> numeric suffix in the embedding/deembedding commands identifies the logical port; see e.g. [CALCulate<Ch>:TRANSform:VNETworks:DIFFerential:EMBedding<LogPt>\[:STATE\]](#).

Network

The graphical list contains the available 2-port networks for Differential Match embedding:

- The  symbol selects "no network" and disables differential match embedding for the selected balanced port.
- The "2-Port Data" network is defined by means of imported S-parameter data; see [Select File...](#)
- The "Shunt L, Shunt C" network is defined by lumped elements whose parameters are displayed below the graphical list.

Tip: Drag and drop the network symbols in horizontal or vertical direction to switch to the next symbol.

Remote command:

```
CALCulate<Ch>:TRANSform:VNETworks:DIFFerential:EMBedding<LogPt>:
TNDefinition
CALCulate<Ch>:TRANSform:VNETworks:DIFFerential:EMBedding<LogPt>:
PARAmeters:L<Cmp>
CALCulate<Ch>:TRANSform:VNETworks:DIFFerential:EMBedding<LogPt>:
PARAmeters:R<Cmp>
CALCulate<Ch>:TRANSform:VNETworks:DIFFerential:EMBedding<LogPt>:
PARAmeters:C<Cmp>
CALCulate<Ch>:TRANSform:VNETworks:DIFFerential:EMBedding<LogPt>:
PARAmeters:G<Cmp>
```

Select File...

"Select File..." is enabled as long as the "2-Port Data" network is selected. This network is defined by its S-parameters stored in a two-port Touchstone file (*.s2p). No additional parameters are required.

Note: The loaded file is stored in the active recall set. Persisted recall sets contain the full (de-)embedding data so that they can be transferred to other instruments.

Remote command:

```
MMEMory:LOAD:VNETworks<Ch>:DIFFerential:EMBedding<LogPt>
```

6.13.10 Config Tab

The "Config" tab provides means to configure the overall "Offset Embed" calculation.

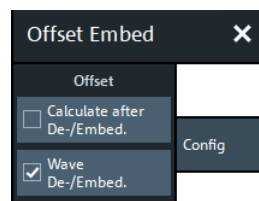

Offset > Calculate after De-/Embed.

Changes the position of the "Offset" calculation in the "Offset Embed" calculation chain.

If unchecked (default), the offset is calculated before de-/embedding. If checked, it is calculated after de-/embedding.

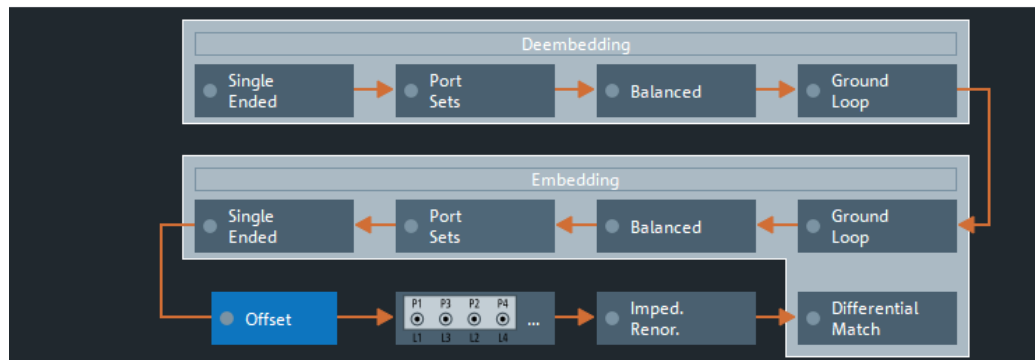
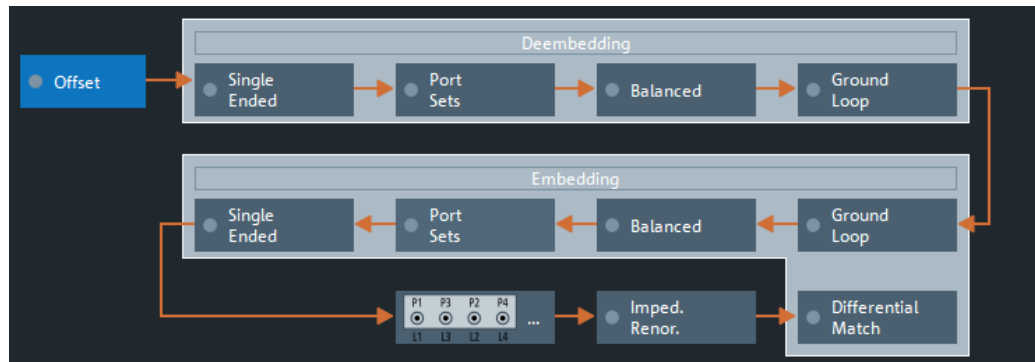

Top = Default offset calculation

Bottom = Offset calculation after de-/embedding (GUI mockup)

Remote command:

```
[SENSe:]CORRection:EDELay:VNETwork
```

Offset > Wave De-/Embed.

If checked, the firmware uses the new, wave-based de-/embedding calculation (default). Otherwise, the legacy S parameter-based calculation is used. See [Chapter 5.1.5, "Data Flow"](#), on page 77.

Remote command:

```
CALCulate<Ch>:TRANSform:VNETworks:WAVes
```

6.13.11 Delta-L Tab

The controls on the "Delta-L" tab allow you to set up and perform a Delta-L PCB characterization.



The "Delta-L" tab is only visible if option R&S ZND-K231 is installed on the instrument. See [Chapter 5.7.11, "Delta-L 4.0 PCB Characterization"](#), on page 204.

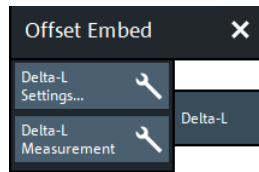

The "Delta-L Settings..." button opens the [Delta-L Settings Dialog](#), which allows you to configure a Delta-L measurement. The "Delta-L Measurement" button runs the configured measurement.

6.13.11.1 Delta-L Settings Dialog

From the "Delta-L Settings" dialog, you can set up the Delta-L measurement channel and how the external tool is run.

Access: CHANNEL – [OFFSET EMBED] > "Delta-L" > "Delta-L Settings..."

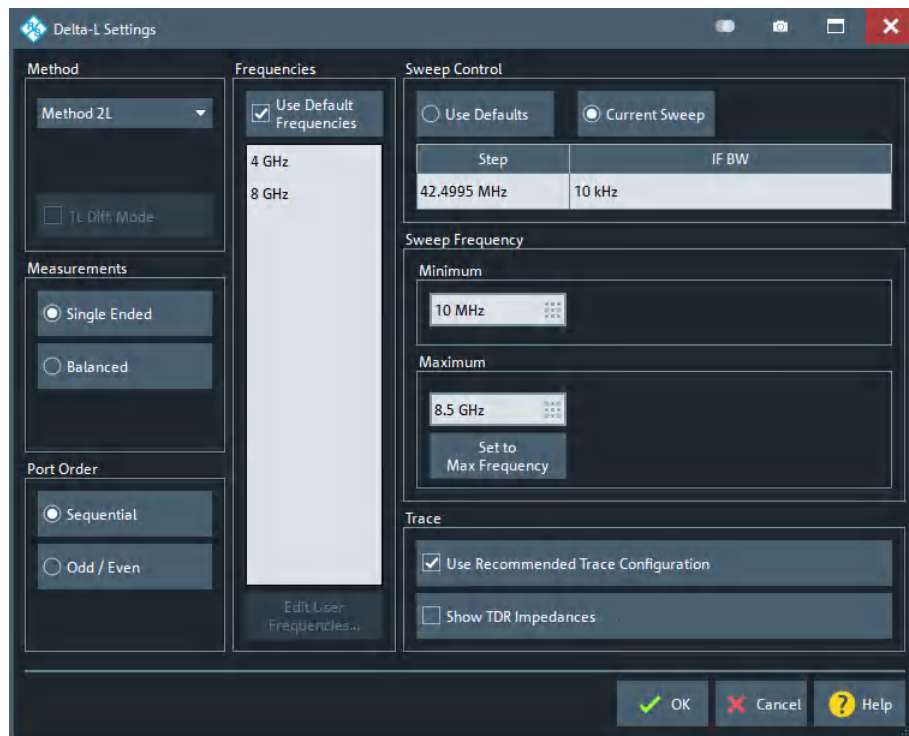

Method

Selects the Delta-L+ characterization method to be used. Default is "Method 2L". For background information, see [Delta-L 4.0 PCB Characterization](#).

"Method 1L" handles single-ended and balanced measurement results differently; activate "1L Diff. Mode" for balanced measurements. For "Method 2L" and "Method 3L" measurements can also be single-ended or balanced, but the tool does not distinguish between them.

Remote command:

`CALCulate:FMOdel:DELT<Ph_pt>:METHod`

`CALCulate:FMOdel:DELT:M1L:DIFFmode`

Measurements

Defines whether single-ended or balanced ports are measured for Delta-L characterizations.

Remote command:

```
CALCulate:FMODEl:DELT:MEASurement
```

Port Order

Declares how the DUT is connected to the measurement system. Choosing the wrong port ordering for your setup, can result in erroneous results.

"Sequential" Ports 1, 2 and 3, 4 form input/output pairs

"Odd / Even" Ports 1, 3 and 2, 4 form input/output pairs

Remote command:

```
CALCulate:FMODEl:DELT<Ph_pt>:PORDer
```

Frequencies

Delta-L computes the uncertainty in the loss-per-inch calculation at specified frequencies.

The "Frequencies" table is pre-populated with the frequencies recommended by Intel. If you want to enter your own values, uncheck "Use Default Frequencies" and select "Edit User Frequencies..." to bring up the "User Frequencies" dialog.

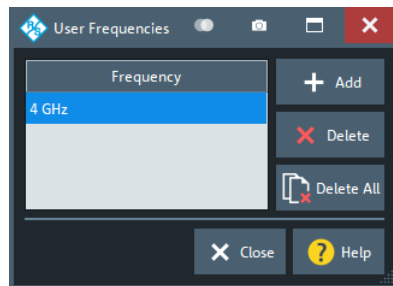

Remote command:

```
CALCulate:FMODEl:DELT<Ph_pt>:FREQuencies:USEDefault
CALCulate:FMODEl:DELT<Ph_pt>:FREQuencies:CURRent?
CALCulate:FMODEl:DELT<Ph_pt>:FREQuencies:CURRent:COUNT?
CALCulate:FMODEl:DELT<Ph_pt>:FREQuencies:DEFault?
CALCulate:FMODEl:DELT<Ph_pt>:FREQuencies:DEFault:COUNT?
CALCulate:FMODEl:DELT<Ph_pt>:FREQuencies:USER?
CALCulate:FMODEl:DELT<Ph_pt>:FREQuencies:USER:COUNT?
CALCulate:FMODEl:DELT<Ph_pt>:FREQuencies:USER:ADD
CALCulate:FMODEl:DELT<Ph_pt>:FREQuencies:USER:DELeTe
CALCulate:FMODEl:DELT<Ph_pt>:FREQuencies:USER:DELeTe:ALL
```

Sweep Control

The Delta-L measurement channel can either "Use Defaults" (10 MHz step size and 1 kHz IF bandwidth), or the "Current Sweep" settings (see "[Freq Step Size](#)" on page 353, and "[Bandwidth](#)" on page 350).

Remote command:

```
CALCulate:FModel:DELT<Ph_pt>:SWEep:CONTRol
CALCulate:FModel:DELT<Ph_pt>:SWEep:CONTRol:STEP?
CALCulate:FModel:DELT<Ph_pt>:SWEep:CONTRol:IFBW?
```

Sweep Frequency

Defines the sweep range of the Delta-L channel. The entered "Minimum" and "Maximum" values are set as [start and stop frequency](#) when the Delta-L settings are applied using "OK". Furthermore, the VNA collects data for the LPI computation at the "Minimum" and "Maximum" frequencies (in addition to the other specified "[Frequencies](#)" on page 479).

The default "Minimum" is the standard Delta-L start frequency of 10 MHz. The default "Maximum" is the instrument's maximum frequency, which can also be set using the "Set to Max Frequency" button.

If you set the "Minimum" to a non-standard value, a popup indicates that the Delta-L measurement possibly does not provide accurate results. Same is true for the "Maximum", which is inevitable, because the standard Delta-L maximum frequencies of 20 GHz and 40 GHz are far beyond the frequency range of the R&S ZND.

Remote command:

```
CALCulate:FModel:DELT<Ph_pt>:SWEep:FREQuency:MINimum on page 637
CALCulate:FModel:DELT<Ph_pt>:SWEep:FREQuency:MAXimum on page 637
```

Trace

On [OK](#), the VNA deletes the existing traces and sets up the traces whose measurement is required for the selected Delta-L [Method](#).

If "[Use Recommended Trace Configuration](#)" is checked, then each of the new traces is displayed in a separate diagram. Otherwise, the VNA places all traces in a single diagram.

If the [Time Domain Analysis](#) option R&S ZND-K2 is installed, "[Show TDR Impedances](#)" adds the TDR-based converted impedance traces to the recommended trace configuration.

Remote command:

```
CALCulate:FModel:DELT<Ph_pt>:TCONfig
CALCulate:FModel:DELT:TDR
```

OK

"OK" applies the Delta-L settings and starts the [Delta-L Measurement](#).

6.13.11.2 Delta-L Measurement

When the Delta-L measurement starts, the analyzer firmware prepares the Delta-L measurement channel, populates the diagram area with the required measurement traces, and opens the [Delta-L Measurement Dock Widget](#).

Delta-L Measurement Dock Widget

The "Delta-L Measurement" dock widget is where coupon measurements are performed and/or corresponding touchstone files are selected.



The **Measurements** setting in the "Delta-L Settings" dialog determines whether single-ended or balanced can be measured. "No ports available!" in the dock widget and "No Trace" in the diagram area indicates that no ports of the selected type are configured.

Access:

- CHANNEL – [OFFSET EMBED] > "Delta-L" > "Delta-L Measurement"
- [Delta-L Settings Dialog](#) > "OK"

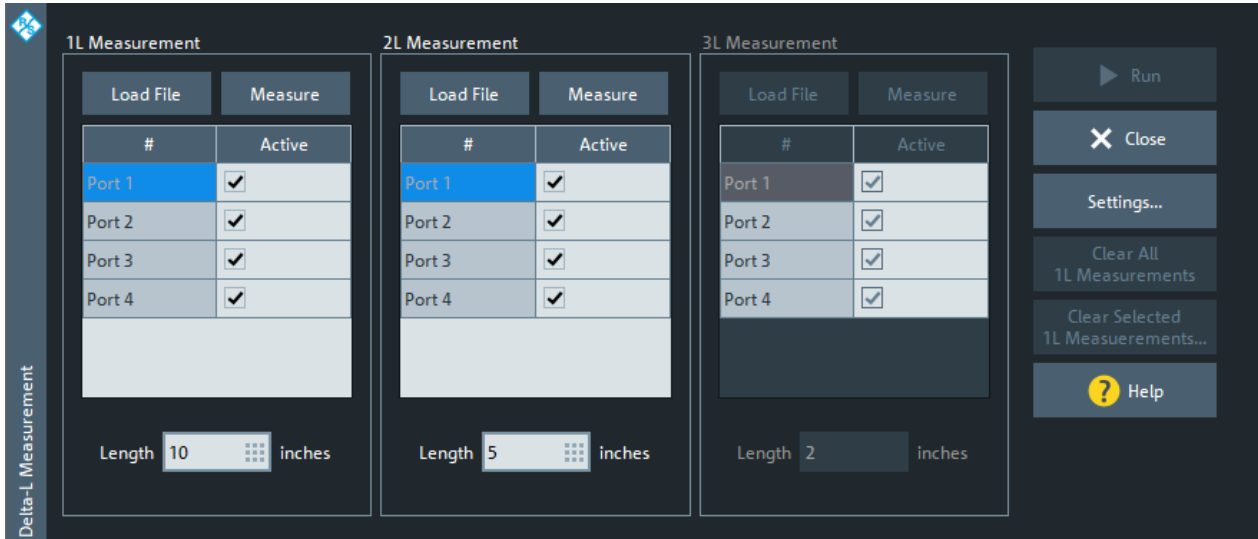

1L Measurement/2L Measurement/3L Measurement

The settings in the "1L Measurement"/"2L Measurement"/"3L Measurement" sections configure and control the measurement of the 1st/2nd/3rd line.

The "1L Measurement" is always enabled. Depending on the selected **"Method"** on page 478, the "2L Measurement" and "3L Measurement" can be disabled.

Load File ← 1L Measurement/2L Measurement/3L Measurement

Loads coupon measurement results from a s2p or s4p Touchstone file.

Remote command:

```
CALCulate:FModel:DELT<Ph_pt>:M1L:FILENAME
```

```
CALCulate:FModel:DELT<Ph_pt>:M2L:FILENAME
```

```
CALCulate:FModel:DELT<Ph_pt>:M3L:FILENAME
```

Measure ← 1L Measurement/2L Measurement/3L Measurement

Measures the full set of S-parameters at the selected **ports** (full 2- or 4-port).

Remote command:

```
CALCulate:FModel:DELT<Ph_pt>:M1L:MEASURE
```

```
CALCulate:FModel:DELT<Ph_pt>:M2L:MEASURE
```

```
CALCulate:FModel:DELT<Ph_pt>:M3L:MEASURE
```

Ports table ← 1L Measurement/2L Measurement/3L Measurement

Use the checkboxes in the "Active" column to include the respective port into the **measurement**.

If [Method 1L](#) is used, four ports have to be selected in the "1L Measurement" section.

Remote command:

```
CALCulate:FModel:DELT<Ph_pt>:M1L[:STATe]
```

```
CALCulate:FModel:DELT<Ph_pt>:M2L[:STATe]
```

```
CALCulate:FModel:DELT<Ph_pt>:M3L[:STATe]
```

Length ← 1L Measurement/2L Measurement/3L Measurement

Specifies the length of the related line.

Remote command:

```
CALCulate:FModel:DELT<Ph_pt>:M1L:LENGth
```

```
CALCulate:FModel:DELT<Ph_pt>:M2L:LENGth
```

```
CALCulate:FModel:DELT<Ph_pt>:M3L:LENGth
```

Run

Runs the AITT-DL tool with the collected measurement data and the configured [Delta-L settings](#).

The firmware enables this action when sufficient data for the required [lines](#) are available (either loaded or measured).

If the AITT-DL tool experiences errors, the analyzer firmware displays additional information (see [<Deembedding Tool> Errors Dialog](#)).

Remote command:

```
CALCulate:FModel:DELT<Ph_pt>:RUN
```

Clear All 1L Measurements/Clear Selected 1L Measurements

If [Method 1L](#) is selected in the "Delta-L Settings" dialog, the VNA firmware builds up a cache of coupon measurements (Touchstone files) in the

DeltaL\1LMeasurementCache subfolder of the user data folder

C:\Users\Public\Documents\Rohde-Schwarz\Vna.

"Clear All 1L Measurements" deletes this cache, "Clear Selected 1L Measurements" displays a "Delete files" dialog that allows you to select the cache files to be deleted.

Remote command:

```
CALCulate:FModel:DELT<Ph_pt>:M1L:CACHe:CLEar:ALL
```

```
CALCulate:FModel:DELT<Ph_pt>:M1L:CACHe:CLEar:SElected
```

Delta-L Diagram

Upon successfully running the external AITT-DL tool, the VNA displays the "Delta-L" diagram.

2L and 3L

For "Method 2L" and "Method 3L", the "Delta-L" diagram includes two traces for every combination of lines/lengths (12 for "Method 2L"; 12, 13, and 23 for "Method 2L")

- Raw traces "DeltaL12", ...
- Smoothed traces "DeltaL12S", ...
Smoothing is performed by the Delta-L algorithm.



Figure 6-30: Method 2L results

Markers are added to the smoothed traces at the [analysis frequencies](#). The marker name indicates to which analysis pair it belongs and the computed Delta-L uncertainty.

Method 1L

For "Method 1L", the Delta-L diagram displays the following traces:

- An insertion loss trace "L<i>" for each touchstone file L<i>.s<2 | 4>p (loaded or measured) in the measurement cache
- An additional trace "StdDev" representing the standard deviation of the 1L analysis at the [analysis frequencies](#)



Markers "DeltaL1..." are added to the "StdDev" trace at the [analysis frequencies](#). The marker names indicate the computed Delta-L uncertainties.

6.14 File Softtool

The "File" softtool allows you to work with recall sets and trace data.

Access: SYSTEM – [FILE]

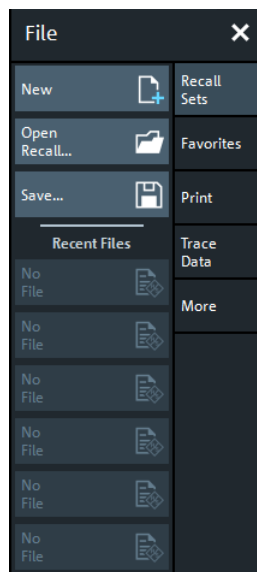

6.14.1 Recall Sets Tab

A recall set comprises a set of diagrams together with the underlying system, channel, trace and display settings. It can be stored to a VNA recall set file (*.znx | *.znxml).

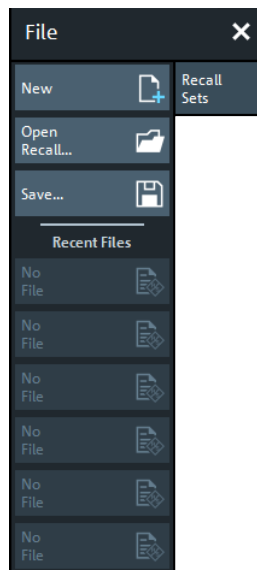

For background information, see [Chapter 5.1.2, "Recall Sets"](#), on page 70.

6.14.1.1 Basic Recall Set Functions

To create a recall set based on the current analyzer configuration, select [Save](#). To open an existing recall set, select [Open Recall....](#) To create an additional setup, select [New](#).



The R&S ZND supports two recall set file formats

- `znx` (default)
Binary file format, supported by all firmware versions of the R&S ZND
- `znxml`
XML based file format, introduced with the R&S ZNA; supported with firmware versions 3.00 and higher

New

Adds a new setup. The default names for new setups are "Set1", "Set2" etc. Recall sets are accessible via tabs in the diagram area:



Tip: To open an existing recall set, use "Open Recall...". To rename a setup, use "Save..."

Remote command:

`MEMory:DEFine`

Open Recall...

Loads a recall set from a file (`*.znx` | `*.znxml`).

Opens the [Open Dialog](#) with suitable file filters.

Check the "32 Bit File Mode" option on the right hand side of this dialog if you want to open a `znx` file that was saved by a 32-bit firmware.

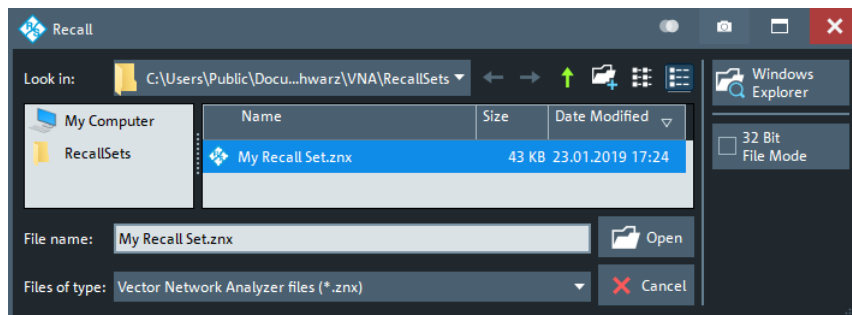

If the current setup includes [External Switch Matrices](#) and the recall set to be loaded does not contain a switch matrix configuration, recalling the setup is aborted. You are requested to delete the configured RF connections (see [Chapter 6.17.5.4, "Switch Matrix RF Connections Dialog"](#), on page 552) and to remove the switch matrix from the RF paths.

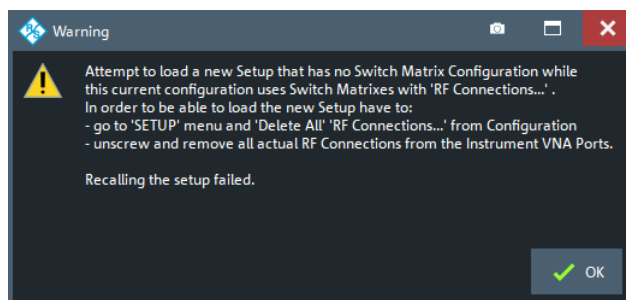

If the recall set to be loaded contains a switch matrix configuration and no differences to the current switch matrix configuration are detected, the recall set is loaded without further inquiry. Otherwise you are asked if you want to adapt the configuration:

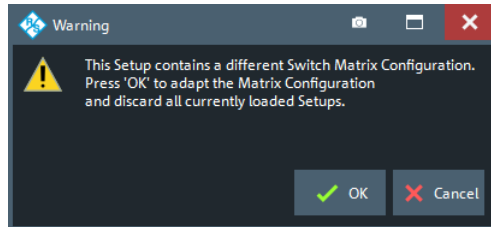

Select "Cancel" to abort the recall process or "OK" to open the [Restore Switch Matrix Configuration Dialog](#) that guides you through the required configuration changes.

Note: In case the recall set could only be loaded after adjusting some incompatible settings, the info message "**The setup data changed while loading**" is displayed. This may happen, for example, if you attempt to load a recall set of a different R&S ZND model or with different optioning.

Remote command:

`MMEMemory:LOAD:STATe`

Save

Saves the active recall set to a file (*.znx | *.znxml).

Displays the [Save Dialog](#) that allows you to specify a file name and location for the recall set file.

Remote command:

`MMEMemory:STORe:STATe`

Recent Files

The buttons are labeled with the last recall sets which were stored in the current or in previous sessions. They open the corresponding recall set.

6.14.1.2 Restore Switch Matrix Configuration Dialog

When opening an existing recall set file, it can be necessary to adapt the current system configuration to the switch matrix configuration of the recall set. The "Restore Switch Matrix Configuration" dialog guides you through this process.

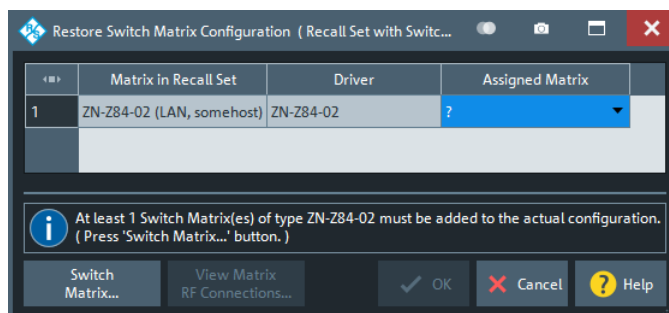

In the dialog proceed as follows:

1. **Reassign Matrices:** For each "Matrix in Recall Set", select a switch matrix of the same (driver) type as "Assigned Matrix".

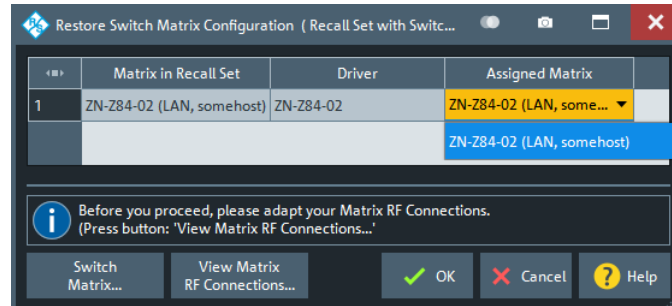

If no switch matrix of the same type exists, select "Switch Matrix" to open the [External Matrices Dialog](#) that allows you to register/configure additional switch matrices.

2. **Restore RF connections:** The recall set's switch matrix configuration comprises the physical RF connections of the related switch matrices. For each "Matrix in Recall Set", select the corresponding row and select "View Matrix RF Connections..." to view the respective matrix RF connections. Make sure that the "Assigned Matrix" is connected accordingly.



Background information

Refer to [Chapter 5.7.20, "External Switch Matrices"](#), on page 210.

View Matrix RF Connections...

This dialog presents the RF connections of a selected switch matrix as specified in the recall set you are about to load.

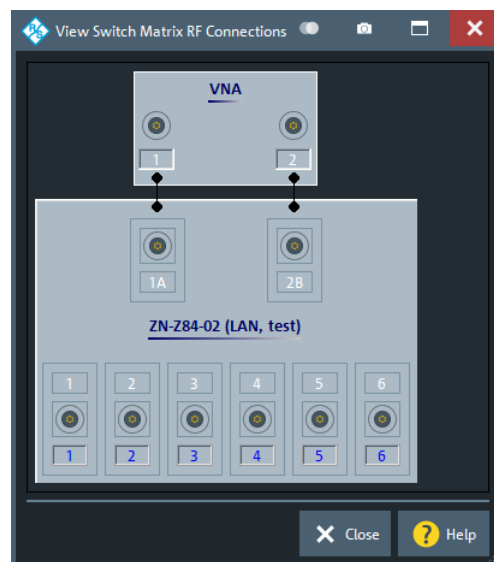

It is a read-only version of the [Switch Matrix RF Connections Dialog](#) you can later use to modify the actual configuration.

6.14.2 Favorites Tab

The "Favorites" tab allows you to manage a list of favorite recall sets.

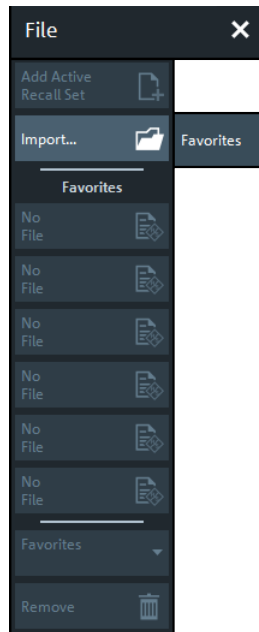

A favorite is actually a path to the related recall set, i.e.

- if the recall set is modified, then the modified recall set is loaded the next time the favorite is selected
- if the recall set is moved or deleted, the corresponding favorite is broken

The firmware can manage up to 6 favorites. New favorites are always created at the topmost spare position in the favorites list. If the list is complete (i.e. if there are no more spare positions), new favorites can only be added after existing ones were removed.

Add Active Recall Set

Adds the active recall set to the list of favorites.

This button is only active if the current setup was loaded from or saved to a recall set.

Import

Opens a file browser that allows you to add an arbitrary recall set to the favorites list.

Remote command:

`MMEMemory:FAVOrite<FavId>`

Favorites section

Select one of the active buttons to open the corresponding recall set.

Favorites combo-box / Remove

Use the "Favorites" combo-box to select the favorite to be removed from the list, then select "Remove"

6.14.3 Print Tab

The buttons on the "Print" tab allow you to send the diagrams of the active setup to an external printer, to a file or to the clipboard. Content and layout can be defined in the [Printer Setup Dialog](#).

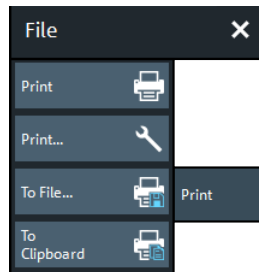

Print

Prints the diagrams using the current content, printer and page settings (see [Chapter 6.14.4, "Printer Setup Dialog"](#), on page 491).

Remote command:

The `HCOPY...` commands provide the printer settings; see [Chapter 8.3.7, "HCOPY Commands"](#), on page 830.

`HCOPY[:IMMEDIATE]` initiates printing.

Print...

Opens a dialog that allows to define the content, printer and page settings (see [Chapter 6.14.4, "Printer Setup Dialog"](#), on page 491).

To File...

Opens the "Save Image" dialog that allows you to select a graphics file type (`*.bmp`, `*.jpg` | `*.jpeg`, `*.pdf`, `*.png`, `*.svg`) and to save diagram content to a file of this type (see also ["Save Dialog"](#) on page 94).

Note that the diagram content to be saved can be configured in the [Content Tab](#) > "Print Charts" group of the "Printer Setup" dialog. E.g., if you select "All diagrams on their own page" there, then only the content of the active diagram is saved to file. If you select "No diagram at all", then "To File..." is disabled.

Remote command:

`HCOPY:DESTINATION`

To Clipboard

Copies diagram content to the clipboard, from where you can paste it into another application.

Note that the diagram content to be copied can be configured in the [Content Tab](#) > "Print Charts" group of the "Printer Setup" dialog. E.g., if you select "All diagrams on their own page" there, then only the content of the active diagram is copied to clipboard. If you select "No diagram at all", then "To Clipboard" is disabled.

6.14.4 Printer Setup Dialog

The "Printer Setup" dialog specifies how the diagram content of, and/or other information on the active recall set is printed. Printer options are specified in three tabs. The lower part of the dialog shows a preview of the print.

Access: SYSTEM – [FILE] > "Print" > "Print..."

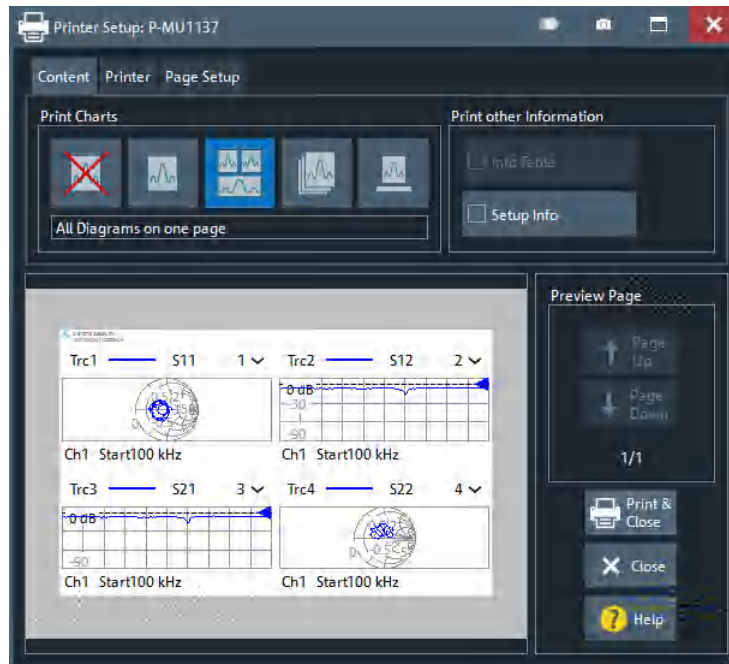

The `HCOPY...` commands provide the printer settings; see [Chapter 8.3.7, "HCOPY Commands"](#), on page 830.

6.14.4.1 Content Tab

The "Content" tab allows you to select the diagram content to be printed.

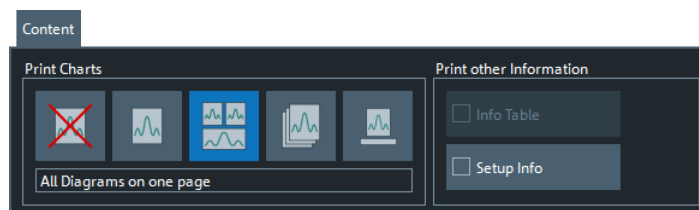

The selected item in the "Print Charts" group specifies how the diagram area of the active recall set is printed. Currently the following options are offered: "No Diagram at all", "Active Diagram only", "All diagrams on one page", "All diagrams on their own page" and "Hard copy of diagram area". The latter is a screenshot of the diagram area, which preserves colors and layout.

Note that the "Print Charts" setting also affects the [To File...](#) and [To Clipboard](#) actions of the [Print Tab](#).

If selected in the "Print other information" group, the content of the "Info Table" (see ["Info Table: Show / Position"](#) on page 510) and/or "Setup Info" (see ["Setup Tab"](#) on page 534) is printed on additional pages.

6.14.4.2 Printer Tab

The "Printer" settings select one of the installed printers and specify printer options.

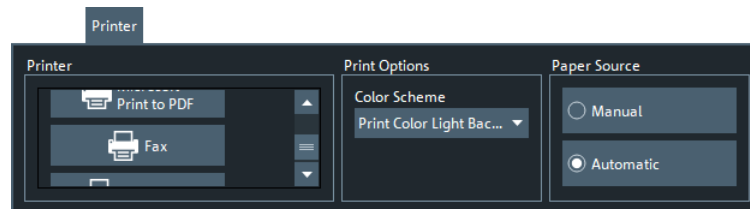

Printers can be installed using the Windows® "Devices and Printers" functionality; see also [Chapter 4.1.9.4, "Connecting a Printer"](#), on page 26.

Print Options

Selects the color scheme to be used for printing. In the current implementation:

- The "User Defined" color scheme can only be configured in the [Define User Color Scheme Dialog](#)
- Modified settings are only applied, if the "User Defined" color scheme is reassigned

Remote command:

`HCOPY:PAGE:COLor`

6.14.4.3 Page Setup Tab

The "Page Setup" settings are visualized in the preview page in the lower part of the dialog.

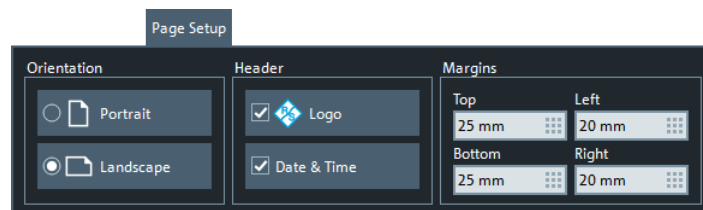

Tip: The printer settings are not affected by a preset of the R&S ZND. Use the "Remote" tab in the [System Config Dialog](#) to restore default settings.

6.14.5 Trace Data Tab

See [Chapter 6.5.11, "Trace Data Tab"](#), on page 296.

6.14.6 More Tab

The "More" buttons load simulation data or close the VNA application.

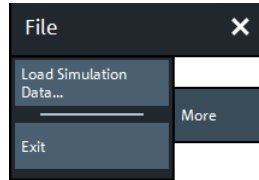

Load Simulation Data...

Imports previously stored trace data into the active diagram. The analyzer opens a dialog box to select the file from all trace files (*.s?p, *.csv, *.dat) stored on the file system; see "Open Dialog" on page 93. The opened trace replaces the active trace.

Exit

Persists the current state of all loaded recall sets and ends the analyzer session. These states are automatically recalled when the analyzer application is restarted.

Tip: This button is equivalent to the Windows® "Close window" command and to the close icon  in the title bar of the main firmware application window.

6.15 Applic Softtool

The "Applic" softtool gives access to applications and tools that extend the functionality of the analyzer firmware.

Access: SYSTEM – [APPLIC]

Use the combo-box at the top of the softtool to load one of the available applications and to display the softtool tabs related to this application.

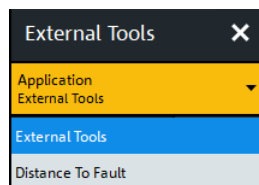

The "External Tools" application is always available, other applications are provided by certain software options.

6.15.1 External Tools Application

The "External Tools" application gives access to pre-installed and user-defined external tools.

Access: SYSTEM – [APPLIC] > "External Tools"

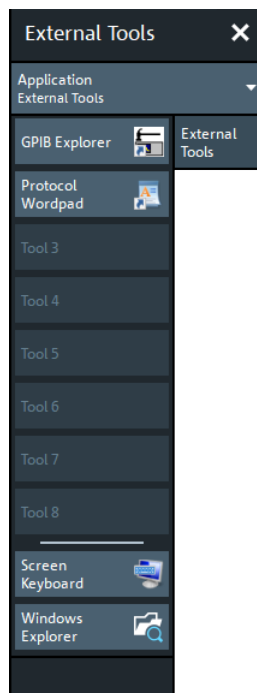

GPIB Explorer

Opens a tool that allows you to connect to the analyzer, obtain an overview of all implemented remote control programs, test programs, compile and run test scripts. For a detailed description, refer to [Chapter 7.1.2, "GPIB Explorer"](#), on page 560.

Protocol Wordpad

Convenience function for opening the WordPad word processor.

This may be used for creating ad hoc measurement protocols, reports etc.

Tool 3 ... Tool 8

Allows you to add your own external tools. Any new shortcut in the `C:\Users\Public\Documents\Rohde-Schwarz\Vna\External Tools` directory replaces one of the buttons.

Title and Bar Task Bar On

Displays or hides the title bar and the task bar across the bottom of the screen. Typically you can use the task bar to change between the VNA application and other external tools. See also [Chapter 4.3.2.1, "Title Bar"](#), on page 41.

Screen Keyboard

Opens the Windows "On-Screen Keyboard". This tool allows you to enter characters, in particular letters, if an input field cannot call up the analyzer's own on-screen keyboard, and if no external keyboard is connected.

See also [Chapter 4.3.5.4, "Using the Windows® On-Screen Keyboard"](#), on page 53.

Windows Explorer

Opens the Windows Explorer and shows you the contents of the `C:\Users\Public\Documents\Rohde-Schwarz\Vna\External Tools` application shortcut directory.

6.15.2 Distance to Fault Application

With option K3, the R&S ZND can locate faults and discontinuities on cables and transmission lines. The measured S_{ij} -parameter trace is mathematically converted to the time domain, and represented in the distance domain. The x-axis of the DtF trace (derived from S_{ij}) shows the distance from the calibrated reference plane; faults appear as peaks above a certain level.

If option R&S ZND-K3 is not installed on the R&S ZND, the "Distance to Fault" application is not available.



To achieve the best distance resolution, set the sweep span as large as possible and use the [Auto Number of Points](#) to adjust the number of sweep points.



Background information

Refer to [Chapter 5.7.6, "Distance-to-Fault Measurements"](#), on page 200.

6.15.2.1 Controls on the Distance to Fault Tab

The controls on the "Distance to Fault" tab allow you to enable and configure a standard Distance to Fault (DtF) measurement.

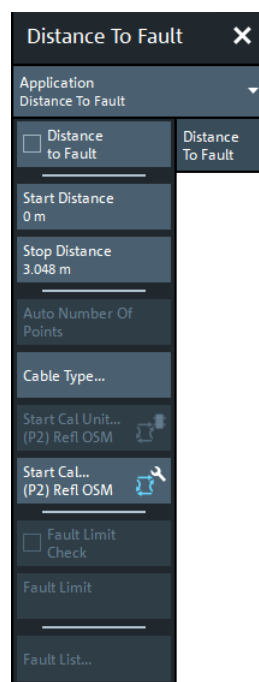

A standard DtF measurement is prepared in the order from top to bottom:

1. Enable DtF measurement, see "[Distance to Fault](#)" on page 496
2. Configure the distance window, see "[Start Distance / Stop Distance](#)" on page 496
3. Adjust the number of sweep points (and, if necessary, the frequency span), see [Auto Number of Points](#)
4. Select (or define and select) a suitable cable type, see "[Cable Type...](#)" on page 498
5. Perform a full one-port calibration at physical port 2, see "[Start Cal Unit... \(P2\) Refl OSM / Start Cal... \(P2\) Refl OSM](#)" on page 498

You should now be able to locate the faults (peaks) by examining the trace.

You can also let the firmware generate a list of faults by enabling [Fault Limit Check](#) and defining a suitable [Fault Limit](#). Use [Fault List...](#) to display (and export) the detected faults.

Distance to Fault

Activates/deactivates Distance to Fault representation for the active trace.

Note that "Distance to Fault" can only be enabled, if the active channel is configured to perform a [linear frequency sweep](#).

For unidirectional R&S ZND, the analyzer always assumes that the DUT is connected to port $p=1$. For bidirectional R&S ZND, if the active trace is a reflection trace S_{ij} , the analyzer firmware assumes that the DUT is connected to port $p=i$. Otherwise it assumes that the DUT is connected to port $p=2$.

When activating "Distance to Fault", the analyzer firmware

- sets S_{pp} as measured quantity of the active trace
- proposes a reflection normalization at port p (see "[Start Cal Unit... \(P2\) Refl OSM / Start Cal... \(P2\) Refl OSM](#)" on page 498)
- enables additional controls on the "Distance to Fault" tab
- appends the selected cable type to the trace label (see "[Cable Type...](#)" on page 498)
- displays an additional "Distance Domain" trace info line below the channel line

Ch1	Start 5 kHz	Pwr -10 dBm	Bw 10 kHz	Stop 3 GHz
Trc1	Start 0 m	Distance Domain	Stop 3.048 m	

Note that all info lines (channel info, trace info, "Distance Domain" trace info) allow quick access to related parameters via specific context menus:

"Distance to Fault" can also be enabled/disabled via the context menu of the trace label.

Remote command:

`CALCulate<Chn>:TRANSform:DTFault:STATe`

Start Distance / Stop Distance

Define the distance window for the Distance to Fault measurement. "Start Distance" and "Stop Distance" correspond to the left and right edge of the diagram area and are displayed in the "Distance Domain" trace info line.

Note:

- If the "Stop Distance" is so high that for the selected [cable type](#) the signal reflected at "far away discontinuities" would be too small, a warning tooltip is displayed:

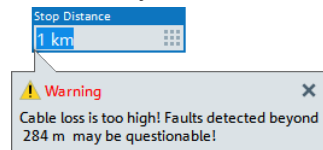

- If the "Stop Distance" exceeds the unambiguous range (for the given frequency span and number of sweep points), a warning is displayed in the instrument status bar:

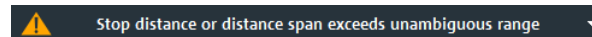

Use the [Auto Number of Points](#) function to adjust the number of sweep points so that the impulse response becomes unambiguous in the configured distance window.

Remote command:

```
CALCulate<Chn>:TRANSform:DTFault:START
CALCulate<Chn>:TRANSform:DTFault:STOP
CALCulate<Chn>:TRANSform:DTFault:CENTER
CALCulate<Chn>:TRANSform:DTFault:SPAN
```

Auto Number of Points

Selects the minimum number of sweep points that are required to provide an unambiguous display of fault locations for the active Distance to Fault trace.

If "Auto Number of Points" actually modifies the [Number of Points](#), a tooltip is displayed:

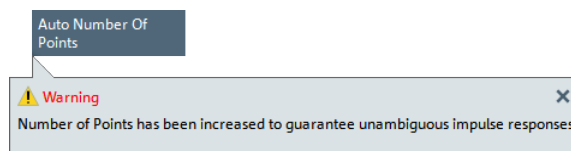

The required number of points depends on:

- the frequency span $\Delta f = f_{stop} - f_{start}$ (see ["Start Frequency / Stop Frequency / Center Frequency / Span Frequency"](#) on page 346),
- the stop distance d_{stop} (see ["Start Distance / Stop Distance"](#) on page 496), and
- the velocity factor v of the transmission line (see ["Cable Type..."](#) on page 498).

With c_0 denoting the speed of light in a vacuum, the analyzer sets the number of sweep points N to

$$N = \max \{ \lceil 2.6 \cdot d_{stop} \cdot \Delta f / (v \cdot c_0) \rceil, 201 \}$$

If the required number of sweep points would be higher than 100001 (the maximum number of sweep points of the R&S ZND), the analyzer sets N to 100001 and displays the following message box:

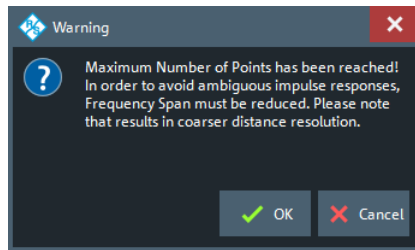

"OK" reduces the frequency span Δf to

$\Delta f = v \cdot c_0 \cdot 100001 / (2.6 \cdot d_{\text{stop}})$, which makes 100001 sweep points sufficient for unambiguous display (see the formula above). However, this reduction of the frequency span comes at the cost of coarser distance resolution.

"Cancel" (default) leaves the frequency unchanged.

Remote command:

`CALCulate<Chn>:TRANSform:DTFault:POINTs`

Cable Type...

Opens a dialog that allows to select a preconfigured cable type to be used for the calculation of the Distance to Fault traces on the active channel. A cable type is defined by its relative permittivity (or its velocity factor), and a frequency-dependent attenuation table.

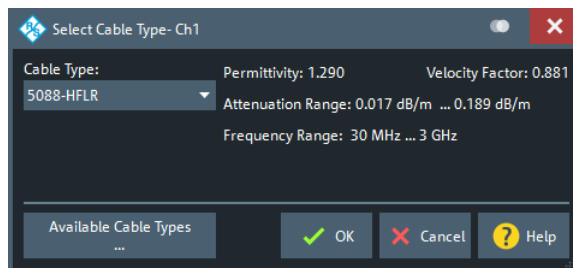

Select "Available Cable Types..." to access the list of predefined and user-defined cable types (see [Chapter 6.15.2.2, "Available Cable Types... Dialog"](#), on page 500).

Remote command:

`CALCulate<Chn>:TRANSform:DTFault:SElect`

Start Cal Unit... (P2) Refl OSM / Start Cal... (P2) Refl OSM

Sets up and runs the "Calibration Unit"/"Calibration Setting" wizard to perform a full one-port calibration at physical port 2 (only port 2 enabled and calibration type "Refl OSM" preselected).

The calibration serves several purposes:

- Adjust the reference plane (distance zero).
- Normalize the trace (total reflection of the signal corresponds to a 0 dB peak).
- Avoid spurious effects, e.g. peaks on the impulse response trace that are not due to a fault.

For descriptions of the calibration wizards and the corresponding remote commands, see [Calibration Unit Wizard](#) and [Calibration Setting Wizard](#).

Note: Make sure to select a sufficient number of sweep points and a suitable frequency span before you start the calibration. Otherwise the measurement can yield inaccurate results.

Use [Auto Number of Points](#) to let the firmware assist you.

Fault Limit Check

Enables/disables checking the current "Distance to Fault" trace for spikes above the given [Fault Limit](#) (red line).

The fault limit is defined relative to the 0 dB-line in the test diagram, i.e. the peak response value for total reflection after proper calibration.

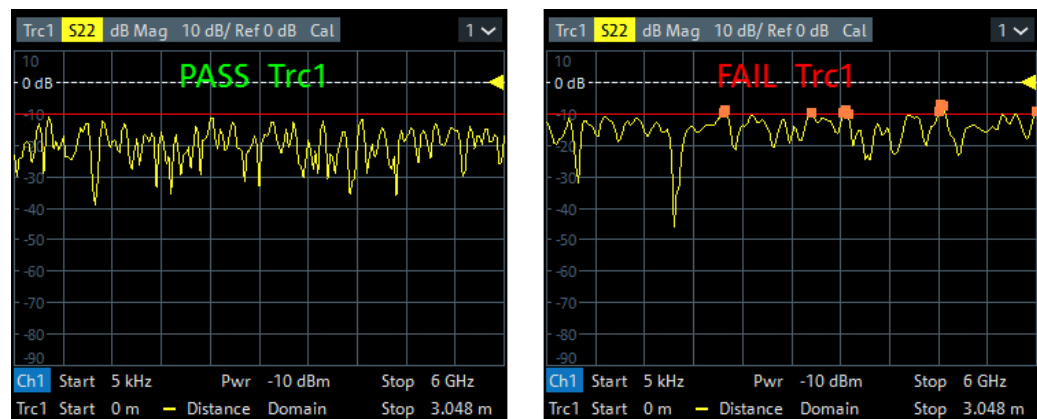

Note that the fault limit is handled like any other limit line. When "Fault Limit Check" is enabled, the current "Fault Limit" forms a new upper line segment replacing other previously defined limit lines (see [Chapter 6.6.1.2, "Define Limit Lines Dialog"](#), on page 308).

Remote command:

```
CALCulate<Chn>:TRANSform:DTFault:PEAK:STATE
```

Fault Limit

Determines the level above which peaks in the active "Distance to Fault" trace are considered as faults.

The fault limit is defined relative to the 0 dB-line in the test diagram, i.e. the peak response value for total reflection after proper calibration.

Note:

- When the "Fault Limit" is modified, the new "Fault Limit" replaces other limit lines (see [Chapter 6.6.1.2, "Define Limit Lines Dialog"](#), on page 308)
- This field is only enabled, if [Fault Limit Check](#) is active.

Remote command:

```
CALCulate<Chn>:TRANSform:DTFault:PEAK:THReshold
```

Fault List...

This button is only enabled, if [Fault Limit Check](#) is active.

It opens the [Fault List Dock Widget](#).

6.15.2.2 Available Cable Types... Dialog

The "Available Cable Types..." dialog allows you to display predefined and user-defined cable types and to add/modify/delete user-defined cable types.

Among the predefined cable types, there is an ideal air line (with a relative permittivity of 1, a corresponding velocity factor of 1, and zero attenuation) and a wide range of standard cable types.

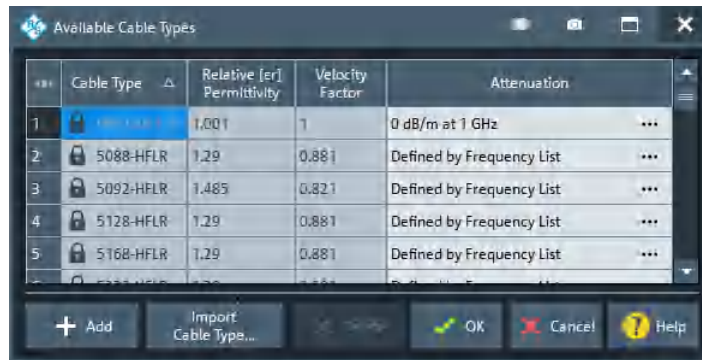

Cable types are defined by their relative permittivity ϵ_r or, equivalently, by their velocity factor $1/\sqrt{\epsilon_r}$, and a frequency-dependent attenuation table (see "[Frequency-Dependent Attenuation Table](#)" on page 500)

The velocity factor is a measure for the velocity of an electromagnetic wave in a dielectric with permittivity ϵ_r , relative to its velocity in a vacuum (velocity factor < 1). It is needed to convert the propagation times into distances.

Frequency-Dependent Attenuation Table

The "Attenuation of <Cable Type>" dialog defines the frequency dependence of the cable attenuation. The measured cables are assumed to be homogeneous so that the attenuation per length unit is constant. This means that the attenuation can be expressed in units of dB/m. Due to the skin effect and various other factors, the attenuation is frequency-dependent.



For predefined cables, the table is read-only.

Access: [Available Cable Types... Dialog](#) > "Attenuation" column > ...

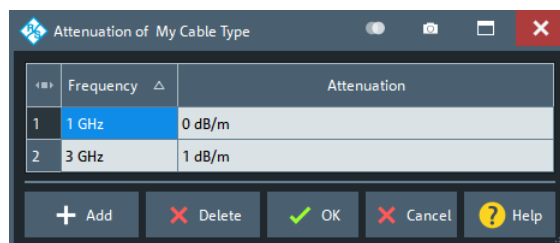

Given the specified attenuation values the R&S ZND calculates the attenuation factor at the center of the channel's sweep range and corrects the impulse response trace using this attenuation factor *Attenuation* (f_{center}).

The frequency dependence can be defined in two alternative ways:

- Single reference frequency**
 If the cable attenuation is specified at a single frequency f_1 , the R&S ZND calculates *Attenuation* (f_{center}) using

$$\text{Attenuation}(f_1) / \text{Attenuation}(f_{center}) = \text{sqrt}(f_1 / f_{center}),$$
 which accounts for the impact of the skin effect.
- Frequency list**
 If the cable attenuation is specified at several frequency points, the R&S ZND calculates the *Attenuation* (f_{center}) by linear interpolation. If f_{center} is below (above) the specified frequency range, then *Attenuation* (f_{center}) is linearly extrapolated from the two lowest (highest) frequency points.



It is recommended to specify the cable attenuation as accurately as possible. The correction due to the attenuation factor is proportional to the measured distance between the fault and the reference plane: The larger the distance, the larger the correction.

Add / Delete

Creates/deletes a user-defined cable type.

Remote command:

```
CALCulate<Chn>:TRANSform:DTFault:DEFine
CALCulate<Chn>:TRANSform:DTFault:DELeTe
MMEMorY:LOAD:CABLe
MMEMorY:STORe:CABLe
```

Import Cable Type

Opens the "Import Cable Type" variant of the [Open File](#) dialog that lets you select a cable type file (*.rsc) for import.

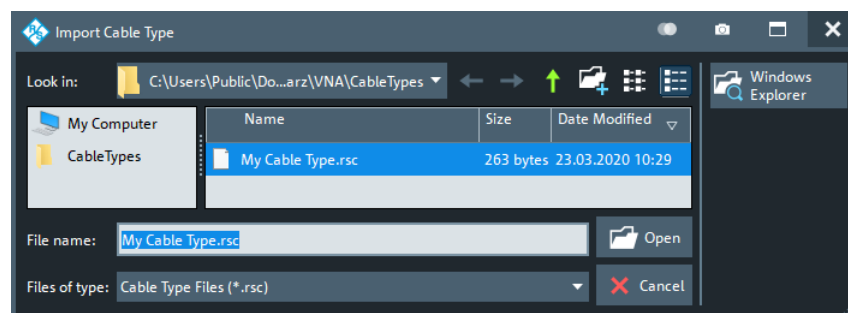

Remote command:

```
MMEMorY:LOAD:CABLe
```

6.15.2.3 Fault List Dock Widget

The "Fault List" dock widget allows you to explore and save all peaks that violate the active [Fault Limit](#).

Access: [Trace] > "Distance to Fault" > "Fault List..."

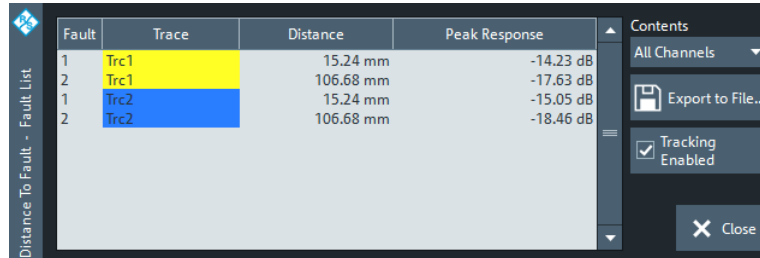

Fault	Trace	Distance	Peak Response
1	Trc1	15.24 mm	-14.23 dB
2	Trc1	106.68 mm	-17.63 dB
1	Trc2	15.24 mm	-15.05 dB
2	Trc2	106.68 mm	-18.46 dB

Contents: All Channels, Export to File..., Tracking Enabled, Close

Figure 6-31: Fault List Dock Widget

Fault Table

The displays a list of all peaks that violate the active [Fault Limit](#). Unless tracking is disabled (see "[Tracking Enabled](#)" on page 503), the table is updated with every sweep.

Remote command:

`CALCulate<Chn>:TRANSform:DTFault:PEAK:COUNT?`

`CALCulate<Chn>:TRANSform:DTFault:PEAK:DATA<FaultNo>`

Contents

Allows you to filter the [Fault Table](#):

- "All Channels" (default)
The table displays the faults of all Distance to Fault traces in the current recall set.
- "Active Channel"
The table displays the faults of all Distance to Fault traces in the active channel (if any).
- "Active Trace"
The table displays the faults of the active trace (in case it is a Distance to Fault trace).

Export to File... ← Contents

Opens a dialog that allows to export the (filtered) content of the fault list to an ASCII file with configurable "Field Separator" and "Decimal Separator".

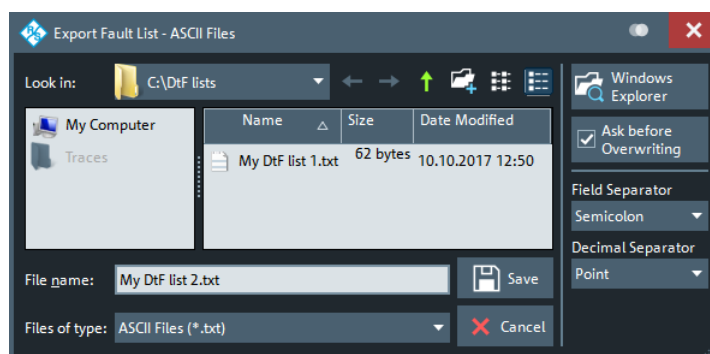

This CSV type file contains one line (terminated by CR+LF) per fault. With ";" as "Field Separator" and "." as "Decimal Separator", the fault list of [Figure 6-31](#) is exported to

```
1; Trc1; 457.2 mm; -8.56 dB
2; Trc1; 1.539 m; -9.24 dB
```

For an explanation of the possible filters, see ["Contents"](#) on page 502).

Tracking Enabled

If checked (default), the ["Fault Table"](#) on page 502 is cleared at every sweep start and populated in real time. Uncheck ["Tracking Enabled"](#) to freeze the table contents.

6.16 Display Softtool

The ["Display"](#) softtool provides all display settings and the functions for activating, modifying and arranging different diagrams.

Access: SYSTEM – [DISPLAY]



Related information

Refer to the following sections:

- [Chapter 5.1.3, "Traces, Channels and Diagrams"](#), on page 70
- [Chapter 5.2.1, "Display Elements of a Diagram"](#), on page 81
- [Chapter 4.3.4, "Handling Diagrams, Traces, and Markers"](#), on page 47

6.16.1 Diagram Tab

Selects a diagram as the active diagram, defines a title, deletes or adds diagrams and arranges them on the screen. Many of the functions are unavailable if the active recall set contains only one diagram.



Related settings

Use the icons in the toolbar to add diagrams and traces. Use the ["Zoom Active Trc"](#) icon to zoom into a rectangular portion inside a diagram. See also [Chapter 4.3.4, "Handling Diagrams, Traces, and Markers"](#), on page 47 and [Chapter 4.3.6.1, "Using the Graphical Zoom"](#), on page 54.

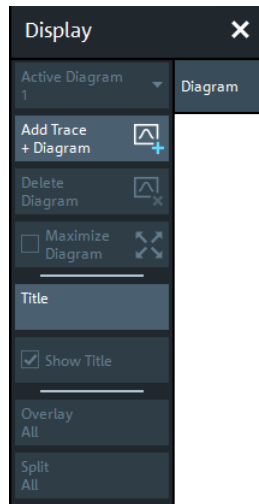

Active Diagram

Selects the active diagram.

Each recall set screen can display several diagrams simultaneously, each with a variable number of traces. One of these diagrams and traces is active at each time. The diagram number (or name) in the upper right corner of the active diagram is highlighted. At the same time, the active trace is highlighted in the trace list on top of the active diagram (Trc3 in the figure below):

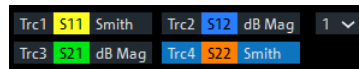

The analyzer provides several tools for activating diagrams:

- tap on a point in the diagram to activate the diagram including the last active trace in the diagram.
- tap on a trace list to activate the trace including the corresponding diagram.
- Some of the functions of the [Traces Tab](#) activate a particular trace including the corresponding diagram.

Remote command:

```
DISPlay[:WINDow<Wnd>]:TRACe<WndTr>:CATalog?
```

Add Tr+Diag

Creates a diagram and a trace which is displayed in the new diagram. The trace is created with the channel settings of the previous active trace but with default trace settings. The new diagram area is numbered <n>, where <n> is the largest of all existing diagram area numbers plus one.

Tip: Dragging the "Trc+" toolbar icon to a new diagram area is similar to "Add Tr +Diag".

Remote command:

```
DISPlay[:WINDow<Wnd>][:STATe] ON
```

Delete Diagram

Deletes the current diagram area including all traces displayed in the diagram area. The remaining diagrams are renumbered; each recall set always contains diagrams with contiguous numbers. "Delete Diag Area" is disabled if the recall set contains only one diagram area: In manual control, each recall set must contain at least one diagram area with one channel and one trace.

Tip: To restore a diagram area that was unintentionally deleted, use the undo functionality.

Remote command:

```
DISPlay[:WINDow<Wnd>][:STATe] OFF
```

Maximize Diagram

Maximizes the active diagram or restores the previous diagram arrangement.

For other split types, use the functions in the [Split Tab](#).

Remote command:

```
DISPlay[:WINDow<Wnd>]:MAXimize
```

Title

Defines a title for the [Active Diagram](#).

The visibility of the title area can be toggled using [Show Title](#).

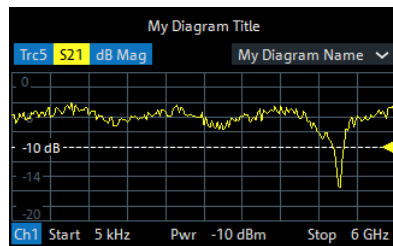

Remote command:

```
DISPlay[:WINDow<Wnd>]:TITLE:DATA
```

Via remote control, it is also possible to define a diagram **name**, and to retrieve the lists of diagrams together with their names:

```
DISPlay[:WINDow<Wnd>]:NAME
```

```
DISPlay[:WINDow<Wnd>]:CATalog?
```

Show Title

Displays or hides the title area of the active diagram.

This property can only be set if [Title](#) is non-empty. If "Title" is empty, the title area is always hidden

Remote command:

```
DISPlay[:WINDow<Wnd>]:TITLE[:STATe]
```

Overlay All

Places all traces in a single diagram area which is maximized to occupy the whole screen. This function is available irrespective of the trace format and the channel settings; it is even possible to overlay Cartesian and complex diagrams.

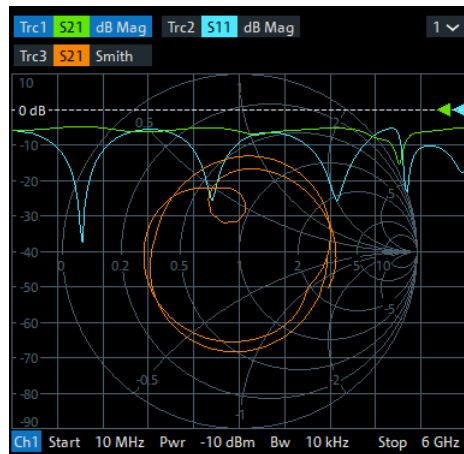

The active trace and active channel is highlighted. The scaling of the axes corresponds to the active trace.

Tip: To hide all traces except one, activate the context menu of the respective trace name segment in the trace list and select "Hide all other Traces".

Remote command:

No command; display configuration only.

Split All

Creates a separate diagram for each trace in the active recall set and automatically arranges those diagrams in the diagram area. Existing diagrams are deleted during this process.

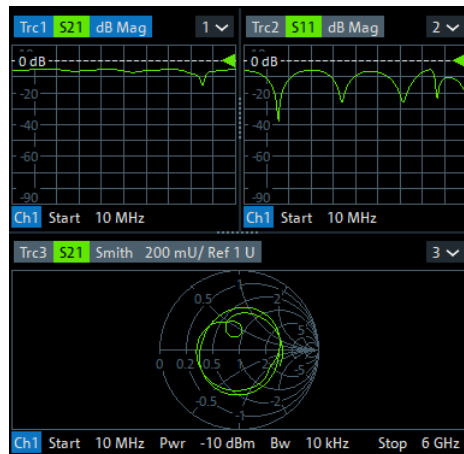

Tip: To vary the size and position of the diagram areas, drag and drop the separating frames or use the functions in the "Split" tab.

Remote command:

No command; display configuration only.

6.16.2 Split Tab

Arranges multiple diagrams on the screen.

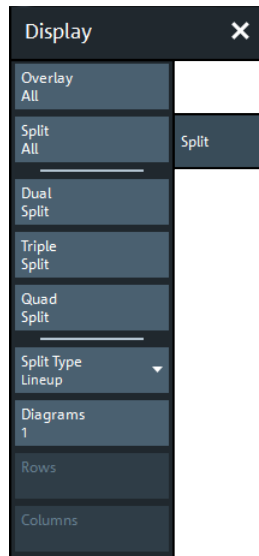

Some of the "Split" settings are also available in the [Diagram Tab](#). Refer to the following sections:

- ["Overlay All"](#) on page 505
- ["Split All"](#) on page 506

Dual Split / Triple Split / Quad Split

Splits the diagram area into two (three / four) diagrams and distributes the traces among the diagrams. Traces with different format and channel settings (e.g. Cartesian and complex diagrams) are separated, if possible. Example of four traces in "Quad Split" display:

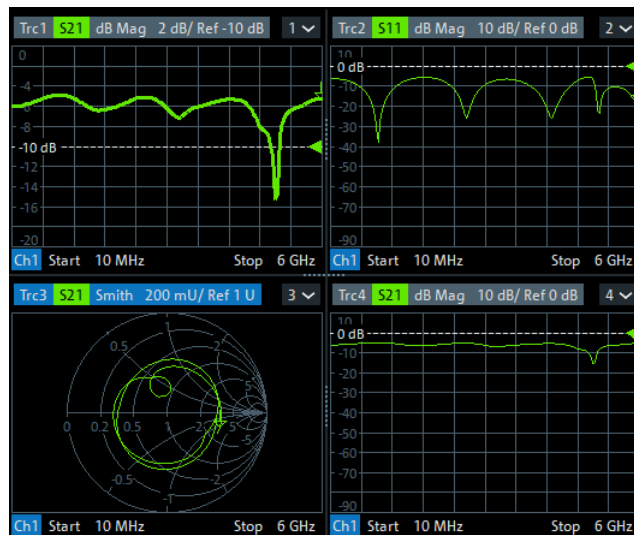

If less than two (three / four) traces are available, the new diagrams are created with a default trace. Dual (triple / quad) split corresponds to "Split Type: Tile Horizontal" with (3 / 4) diagrams.

Tip: To vary the size and position of the diagrams, drag and drop the separating frames or use the functions in the "Diagram" tab.

Remote command:

No command; display configuration only.

Split Type

The R&S ZND provides the following split types:

- "Lineup": The diagrams are arranged side by side; each diagram occupies the entire screen height.
- "Stack": The diagrams are arranged one below the other; each diagram occupies the entire screen width.
- "Tile Horizontal": The diagrams are arranged in rows. With 2 (3 / 4) diagrams, the result is equivalent to Dual Split (Triple Split / Quad Split); see ["Dual Split / Triple Split / Quad Split"](#) on page 507.
- "Tile Vertical": The diagrams are arranged in columns.
- "Rows + Cols": The diagrams are arranged as a rectangular matrix. The number of rows and columns is as defined in the corresponding input fields.

If the selected number of "Diagrams" exceeds the number of traces, some of the new diagrams are created with a default trace.

Tip: To vary the size and position of the diagrams, drag and drop the separating frames or use the functions in the "Diagram" tab.

Remote command:

`DISPlay:LAYout`

Diagrams / Rows / Columns

Selects the number of "Diagrams" (or "Rows" and "Columns") to which the traces in the active recall set are split. The split is performed according to the selected [Split Type](#).

If the entered number of "Diagrams" exceeds the number of previously existing traces, some of the new diagrams are created with default traces.

For a "Split Type" other than "Rows + Cols", only the total number of "Diagrams" can be specified.

Remote command:

`DISPlay:LAYout:GRID`

Additional Functionality: SCPI Commands

The analyzer provides remote control commands for efficient diagram handling. The commands listed below extend the functionality of the "Display > Diagram" and "Display > Split" softtool panels. For programming examples, refer to [Chapter 9.2.2.6, "Creating Diagrams"](#), on page 1127.

Remote command:

`DISPlay:LAYout:APPLY`

`DISPlay:LAYout:DEFine`

`DISPlay:LAYout:EXECute`

`DISPlay:LAYout:JOIN`

6.16.3 Config Tab

Displays or hides controls and information elements of the screen and controls the appearance of the individual diagrams.

Hiding the controls and information elements leaves more space for the diagrams. All elements can be shown or hidden simultaneously.



Related information

Refer to [Chapter 5.2.1, "Display Elements of a Diagram"](#), on page 81.

6.16.3.1 Controls on the Config Tab

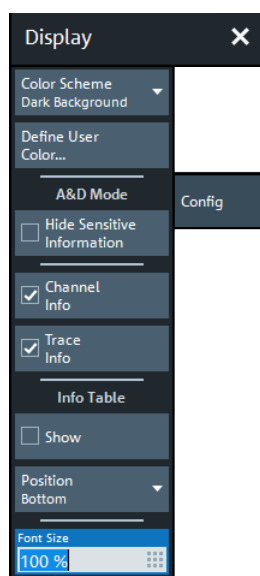

Color Scheme

Controls the colors in the diagram areas. Color schemes are global settings and apply to all active recall sets.

The following predefined color schemes are optimized for the analyzer screen and for color hardcopies, respectively:

- "Dark Background" sets a black background color. The traces and information elements in the diagram areas are displayed in different colors. This setting is usually suitable for observing results on the analyzer screen.
- "Light Background" sets a light background color. The traces and information elements in the diagram areas are displayed in different colors. This setting is suitable for generating color hardcopies of the screen.

The following predefined color schemes can be appropriate for generating black and white hardcopies of the screen:

- "Black and White Line Styles" sets a white background color. All traces and information elements in the diagram areas are black, however, the traces are drawn in different line styles.

- "Black and White Solid" sets a white background color. All traces and information elements in the diagram areas are black. All traces are drawn with solid lines.

"User Define..." opens a dialog to modify the predefined schemes, changing the colors and styles of the individual display elements.

See [Chapter 6.16.3.2, "Define User Color Scheme Dialog"](#), on page 511.

Remote command:

`SYSTem:DISPlay:COLor`

Hide Sensitive Information

Unmasks or masks all stimulus value occurrences in the VNA GUI for the current recall set.

When you check "Hide Sensitive Information" for a particular recall set (to mask the stimulus values), you are asked to set a password. If this password is non-empty, it is requested the next time someone tries to uncheck "Hide Sensitive Information" (to unmask all stimulus values) for this recall set.

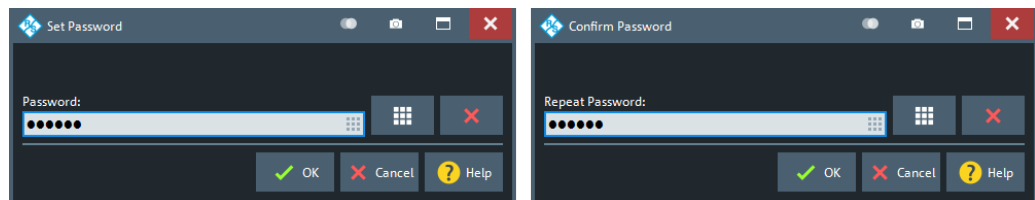

Both checked state and password are stored in (and loaded from) the active recall set.

Remote command:

`DISPlay:ANNOtation:FREQuency[:STATE]`

Channel Info

Shows or hides the channel lists in the lower part of the diagrams.

Ch1	Start	5 kHz	—	Pwr	-10 dBm	Bw	10 kHz	Stop	6 GHz
Ch2	Freq	1 GHz	—	Pwr	-10 dBm	Bw	10 kHz	Stop	201
Ch3	Freq	1 GHz	—	Pwr	-10 dBm	Bw	10 kHz	Stop	1 s
Ch4	Start	5 kHz	—	Pwr	-10 dBm	Bw	10 kHz	Stop	6 GHz
Trc4	Start	-1 ns	—	Time	Domain			Stop	4 ns

Remote command:

`DISPlay:ANNOtation:CHANnel[:STATE]`

Trace Info

Shows or hides the trace lists in the upper part of the diagrams.

Trc1	S11	Smith	Trc2	S12	dB Mag	1	▼
Trc3	S21	dB Mag	Trc4	S22	Smith		

Remote command:

`DISPlay:ANNOtation:TRACe[:STATE]`

Info Table: Show / Position

Shows or hides the info table and defines its position.

The info table is a possible container for info fields and can be placed to the bottom, to the left, or to the right of the screen. See also [Chapter 6.7.8, "Info Field Tab"](#), on page 343.

M1	Trc1	5.130001	GHz	-15.6388	dB	Bandstop Trc1	Ref to Max	Track
• M2	Trc1	4.718891	GHz	-7.3323	dB	Bandwidth	535.657892	MHz
M3	Trc1	5.254549	GHz	-7.3323	dB	Center	4.979523	GHz
M4	Trc1	4.979523	GHz	-9.5924	dB	Lower Edge	4.718891	GHz
						Upper Edge	5.254549	GHz
						Quality Factor (3dB)	9.296	U
						Loss	15.6388	dB

Remote command:

No command; display configuration only.

Info Window

Shows/hides the [Info Window](#)

Remote command:

`DISPlay: IWINdow[: STATE]`

Font Size

Scales the fonts in the diagrams. The scaling affects the trace and channel lists, and the info fields.

Remote command:

`DISPlay: RFSize`

6.16.3.2 Define User Color Scheme Dialog

The "Define User Color Scheme" dialog modifies the predefined color schemes, changing the colors and styles of the individual display elements. User-defined color schemes can be saved to a file for later re-use.

Access: SYSTEM – [DISPLAY] > "Config" > "Define User Color..."



Related settings

Refer to ["Color Scheme"](#) on page 509.

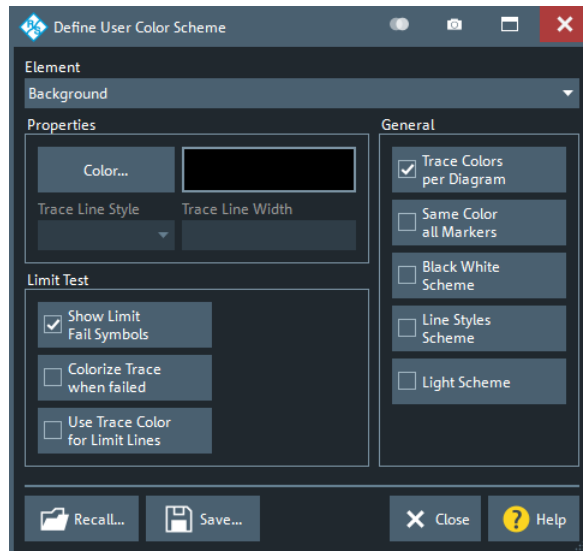

Element

Selects the screen element to be modified. The list contains the background and all traces (more precisely trace properties), text elements and lines in the diagrams.

The maximum number of trace properties can be configured in the "User Interface" tab of the "System Config" dialog (see ["Number of Trace Colors"](#) on page 524).

Remote command:

The `<DispEl>` suffix in the `DISPlay:CMAP<DispEl>...` commands identifies the screen element. See [DISPlay:CMAP<DispEl>:RGB](#).

Properties

Configures the selected screen element.

- "Color" opens a standard color dialog where you can assign a color to the selected element.
- "Trace Line Style" and "Trace Line Width" are enabled if the selected element is a trace.

Remote command:

[DISPlay:CMAP<DispEl>:RGB](#)

[DISPlay:CMAP:TRACe:RGB](#)

Limit Test > Show Limit Fail Symbols

Displays or hides the colored squares on the trace indicating failed measurement points. Hide the squares if they cover too much of the trace. Instead of using the limit fail symbols, you can colorize the trace to highlight failed trace sections.

Remote command:

[DISPlay:CMAP:LIMit:FSYMBOL\[:STATE\]](#)

Limit Test > Colorize Trace when Failed

Assigns a different trace color to failed trace segments.

The different color reaches from the last passed measurement point before the start of the failed segment to the last failed measurement point in the segment. Consequently, the colored trace segment can begin before the begin of the failed range and can end before its end.

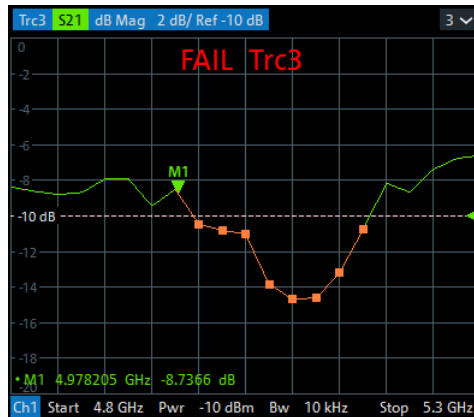

Remote command:

```
DISPlay:CMAP:LIMit:FCOLorize[:STATe]
```

Limit Test > Use Trc Color for Limit Lines

Assigns the trace color to all limit line segments associated with the trace. All other limit line color definitions are ignored.

Remote command:

```
DISPlay:CMAP:LIMit[:STATe]
```

General > Trace Colors per Diagram

Controls the color of traces that are created in a diagram or moved to another diagram.

- If "Trace Colors per Diagram" is enabled (factory preset), all diagrams use the same trace colors. The first trace in each diagram gets trace color 1, the second trace color 2 etc. (cyclically).
In particular, if a trace is removed from a diagram, then all traces in this diagram that were created after the removed one, will change their color. And if this trace is moved to another diagram, its color typically changes as well.
- If "Trace Colors per Diagram" is disabled, then the traces are colored with trace colors 1 to 8 (cyclically) in the order they are created. No matter to which diagram they are assigned.
All traces keep their original trace color (number).

Remote command:

```
DISPlay:CMAP:TRACe:COLor[:STATe]
```

General > Same Color all Markers

Selects a common marker color, which is independent of the trace colors.

Remote command:

```
DISPlay:CMAP:MARKer[:STATe]
```

General > Black White Scheme / Line Styles Scheme / Light Scheme

Modifies the user color scheme, in particular the trace and channel lines, in a predefined way. As an alternative, select predefined color schemes; see ["Color Scheme"](#) on page 509.

Remote command:

`DISPlay:CMAP<DispEl>:RGB`

Recall... / Save...

Opens standard dialogs to recall a previously saved color scheme or save the current scheme to a file. Color scheme files are non-editable files with the extension *.ColorScheme; the default directory is

`C:\Users\Public\Documents\Rohde-Schwarz\Vna\ColorSchemes.`

Remote command:

`MMEMoRY:STORe:CMAP`

`MMEMoRY:LOAD:CMAP`

6.16.3.3 Info Window

The "Info Window" displays a configurable set of marker properties and [Bandfilter Search](#) results. It automatically resizes the displayed text to fit the window height and width.

Access: SYSTEM – [DISPLAY] > "Config" > "Info Window" checkbox

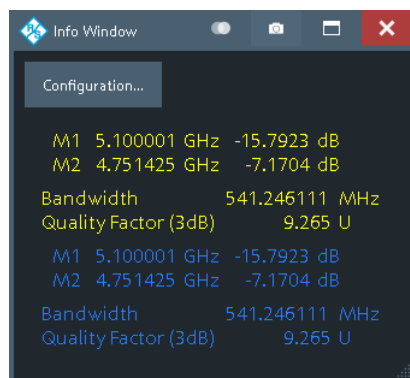

Use the "Configuration..." button to open the [Info Window Configuration Dialog](#) and select the information items to be displayed.

To disambiguate the displayed marker info fields, you can assign descriptive names to the markers (see ["Marker Name"](#) on page 326).



If a trace is hidden, then its marker and bandfilter search info is also hidden in the "Info Window".

Info Window Configuration Dialog

The "Info Window Configuration" dialog allows you to select the markers and [Display Elements of a Diagram](#) results to be displayed in the [Info Window](#).

Access: [Info Window](#) > "Configuration..."

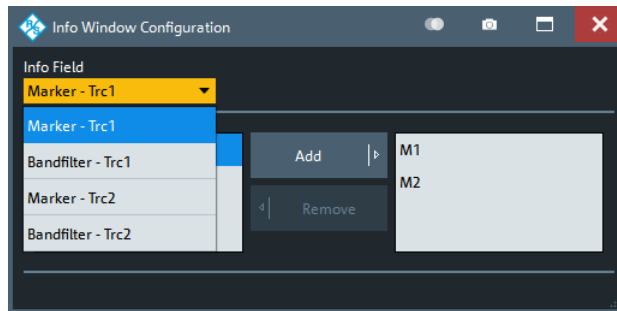

Use the "Info Field" combo box to select a marker or bandfilter search info field whose contents you want to display in parts or in total. It contains all info fields of the current recall set that are currently not displayed in the info table (see ["Info Table: Show / Position"](#) on page 510).

Content Selection

The lower part of the "Info Window Configuration" dialog allows you to pick the contents of the selected info field you want to display in the [Info Window](#).

For marker info fields, use the "Add" and "Remove" buttons to show/hide the selected marker in the "Info Window".

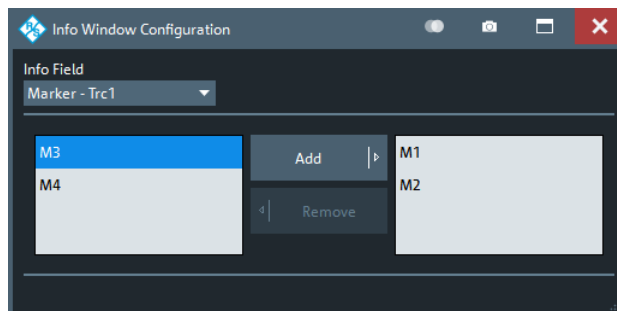

Figure 6-32: Content selection: marker info fields

For [Bandfilter Search](#) info fields simply pick the results to be displayed.

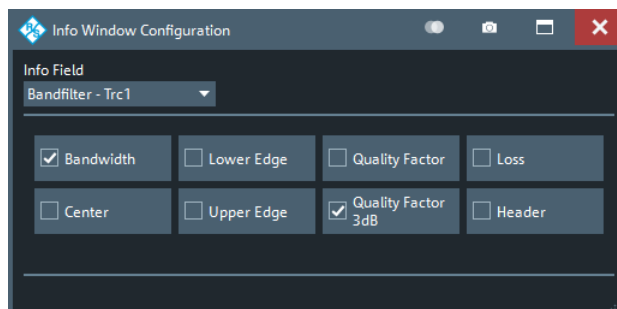

Figure 6-33: Content selection: bandfilter search info fields

Remote command:

```
DISPlay: IWINdow: MARKer<Mk> [ : STATE]
```

```
DISPlay: IWINdow: BFILter [ : STATE]
```

6.16.4 View Bar Tab

Displays or hides information panels and bars of the graphical user interface. Hiding the information elements leaves more space for the diagrams. All elements can be shown or hidden simultaneously.

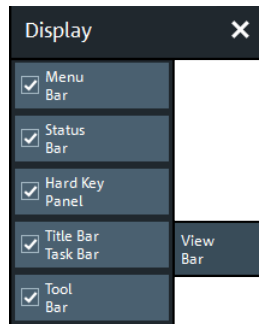

Menu Bar

Toggles the visibility of the "Menu Bar".

For background information, see [Chapter 4.3.2.4, "Menu Bar"](#), on page 43.

Remote command:

```
SYSTem:DISPlay:BAR:MENU[:STATe]
```

Status Bar

Toggles the visibility of the "Status Bar".

For background information, see [Chapter 4.3.2.7, "Status Bar"](#), on page 45.

Remote command:

```
SYSTem:DISPlay:BAR:STATus[:STATe]
```

Hard Key Panel

Toggles the visibility of the "Hard Key Panel".

For background information, see [Chapter 4.3.2.6, "Hardkey Panel"](#), on page 45.

The "Hard Key Panel" can also be closed via the "X" button in its top right corner.

Remote command:

```
SYSTem:DISPlay:BAR:HKEY[:STATe]
```

Title Bar Task Bar

Toggles the visibility of the title bar of the VNA application window and the Windows® task bar.

If unchecked (default) the VNA application is displayed in full screen mode with invisible title bar and Windows® task bar. If checked it is displayed as a regular window.

For background information, see [Chapter 4.3.2.1, "Title Bar"](#), on page 41.

Remote command:

```
SYSTem:DISPlay:BAR:TITLe[:STATe]
```

Tool Bar

Toggles the visibility of the "Tool Bar".

For background information, see [Chapter 4.3.2.2, "Toolbar"](#), on page 41.

Remote command:

```
SYSTem:DISPlay:BAR:TOOLs[:STATe]
```

Additional Function: Minimize/Maximize the Softtool Panel

The softtool panel can be minimized/maximized via the "X"/hamburger icon in its top right corner.

Remote command:

```
SYSTem:DISPlay:BAR:STOOLs[:STATe]
```

6.16.5 Touchscreen Tab

Allows you to lock the touchscreen functionality of the R&S ZND to prevent inadvertent entries.

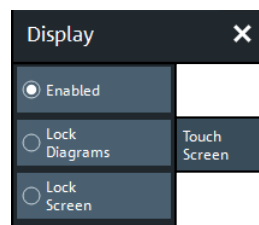

Enabled / Lock Diagrams / Lock Screen

- "Enabled" – touchscreen control of the R&S ZND fully enabled. All control elements are active.
- Lock diagrams – drag and drop functions in the diagrams are disabled, all other control elements (e.g. the softtool panels) are still active.
- Lock screen – all control elements are locked. Pressing any front panel key on the analyzer (or sending `SYSTem:TSLock OFF`) re-enables touchscreen control.

Remote command:

```
SYSTem:TSLock
```

6.17 Setup Softtool

The "Setup" softtool allows you to define various system-related settings, to manage global resources, to get system information and to execute service functions.

Access: SYSTEM – [SETUP]



Persistent vs. session settings

The settings in the "Setup" softtool and the configuration dialogs are global settings and not affected by a "Preset" or shutdown of the analyzer.

6.17.1 Setup Tab

Gives access to system-wide properties, settings, resources and service functions.

6.17.1.1 Controls on the Setup Tab

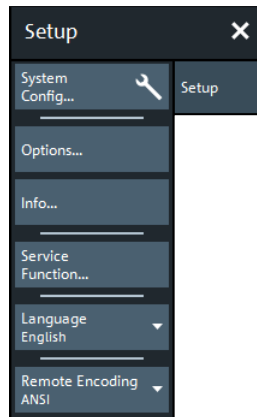

The following buttons in the "Setup" tab open related dialogs:

- **"System Config...":** [System Config Dialog](#)
- **"Options...":** "Info" dialog > [Options Tab](#)
- **"Info...":** "Info" dialog > [Setup Tab](#)
- **"Execute Selftest...":** "Info" dialog > [Selftest Tab](#)
(Runs the selftest first)
- **"Service Function...":** [Service Function Dialog](#)

Language

Selects the language of the graphical user interface. A message box indicates that the vector network analyzer application needs to be restarted to activate a different language.

English is the preinstalled language. A setup file for additional languages ("Vector Network Analyzer Translation Setup") is available for download from the [Rohde & Schwarz Internet site](#).

Remote command:

n/a

Remote Encoding

Selects the character encoding used at the remote interface. The selected encoding applies to directory and file names, calibration kit names, calibration unit characterizations and display titles.

Currently the following encodings are supported: ANSI (default), UTF-8, Shift JIS.

Remote command:

`SYSTem:COMMunicate:CODEc`

6.17.1.2 System Config Dialog

The "System Config" dialog allows you to define global settings that are not affected by an instrument reset. See [Chapter 5.1.1, "Global \(Persistent\) Settings"](#), on page 69.

Access: SYSTEM – [SETUP] > "Setup" > "System Config..."

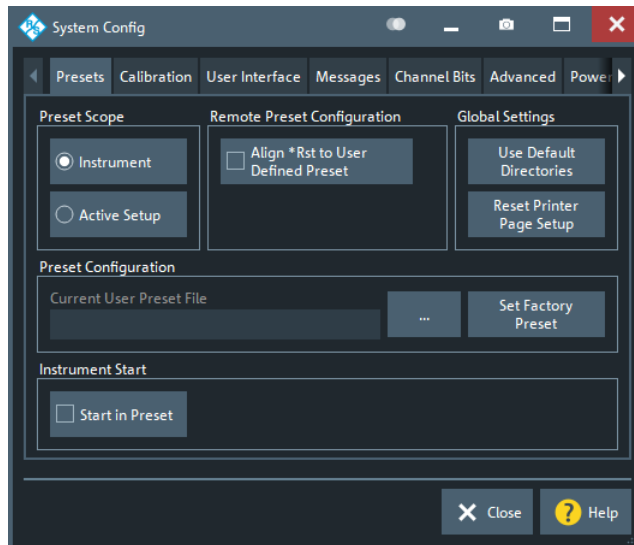

- [Presets Tab](#)..... 519
- [Calibration Tab](#)..... 521
- [User Interface Tab](#)..... 522
- [Messages Tab](#)..... 524
- [Channel Bits Tab](#)..... 525
- [Advanced Tab](#)..... 526
- [Power Tab](#)..... 528
- [Recovery Tab](#)..... 529
- [HUMS Tab](#)..... 530

Presets Tab

Specifies the behavior of the R&S ZND upon a preset.

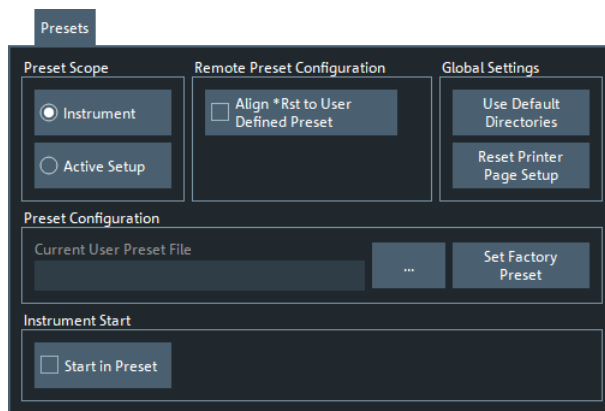

Preset Scope

Defines whether a preset affects all open recall sets ("Instrument") or the active recall set only.

The "Preset Scope" applies to the GUI and to the `SYSTEM:PRESet[:DUMMy]` command. The `*RST` command always resets all open recall sets.

Remote command:

`SYSTEM:PRESet:SCOPE`

Remote Preset Configuration

"Align *RST to User Defined Preset" defines the behavior of the `*RST` and `SYSTEM:PRESet` commands. If checked, and if a valid setup file is selected in the [Preset Configuration](#) section, then they perform a user-defined preset. Otherwise, they perform a factory preset.

Remote command:

`SYSTEM:PRESet:REMOte[:STATe]`

Global Settings

The two buttons reset all directory settings (e.g. the directories for storing trace data, limit lines, calibration data...) and all settings in the "Printer Setup" dialog to default values. See [Chapter 6.14.4, "Printer Setup Dialog"](#), on page 491.

Remote command:

n/a

Preset Configuration

Specifies whether the preset action performs a factory preset or restores a user preset file. A user preset file is an arbitrary recall set file (`*.znx|*.znxml`), that can be created from the active setup using `SYSTEM – [FILE] > "Save..."`. If the current user preset file is not found (e.g. because it was deleted or moved), `SYSTEM – [PRESET]` initiates a factory preset.

The preset configuration applies to:

- the `SYSTEM – [PRESET]` hardkey
- the remote commands `*RST` and `SYSTEM:PRESet` (if "Align *RST to User Defined Preset" is selected in the [Remote Preset Configuration](#) section).

Furthermore, the user preset file is used as a template, whenever [New](#) recall set files are created from the GUI.

Remote command:

`SYSTEM:PRESet:USER:NAME`

`SYSTEM:PRESet:USER[:STATe]`

Start in Preset

If this option is active, the R&S ZND FW always starts with the configured [Preset Configuration](#). Otherwise it starts with the previous state, i.e. the settings that were persisted during the previous shutdown.

Remote command:

`SYSTEM:PRESet:START`

Calibration Tab

Provides general system error correction (calibration) settings.

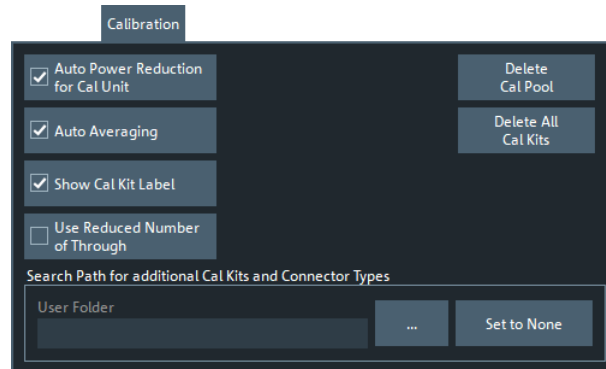

Auto Power Setting for Cal Unit

Sets the source power at all test ports to -10 dBm while an automatic calibration is active. Applying this source power to the ports of the calibration unit ensures best accuracy of the automatic calibration. The source powers are reset to their original values after the calibration is completed. The automatic power reduction can be deactivated in case that the test setup introduces a large attenuation.

Remote command:

```
SYSTem:COMMunicate:RDEvice:AKAL:PREduction[:STATe]
```

Auto Averaging

Activates automatic averaging, which means that the VNA performs multiple calibration sweeps and applies averaging to reduce trace noise. In contrast to regular averaging (see [Chapter 6.9.3, "Average Tab"](#), on page 350), the number of calibration sweeps is calculated automatically.

Remote command:

```
[SENSe:]CORrection:COLLect:AVERage
```

Show Cal Kit Label

Enables/disables the "Calibration Info" dialog during manual calibration (see ["Start Cal Sweep"](#) on page 391).

Independent of the state of the "Show Cal Kit Label" flag, cal kit labels are displayed in several other manual calibration dialogs.

Use Reduced Number of Through

Enables or disables the [Reduced Through](#) logic for every port assignment of an automatic calibration.

Note that for this to work, the port assignments must have a star topology, with a "Common Port" set using `[SENSe<Ch>:]CORrection:COLLect:AUTO:CPORT` on page 922.

Remote command:

```
[SENSe:]CORrection:COLLect:AUTO:MCONnect
```

Delete Cal Pool / Delete All Cal Kits

Deletes all calibration data and all cal kit data. See [Chapter 6.11.4.3, "Calibration Manager Dialog"](#), on page 423.

Remote command:

n/a

Search Path for additional Cal Kits and Connector Types

Contains the name and path of a special directory for cal kit files (*.calkit). All cal kit files in the special directory are loaded automatically as predefined kits (i.e. read-only kits which cannot be modified) every time the VNA application is started. It is possible to select the default cal kit directory

C:\Users\Public\Documents\Rohde-Schwarz\Vna\Calibration\Kits or any other directory. "None" means that no additional cal kit files are loaded on start-up.

Use the special directory to make sure that you do not have to import kits manually, even after terminating the VNA application improperly. In this case, previously imported cal kit files are not stored in the recall set file.

Remote command:

MMEMory:LOAD:CKIT:UDIRectory

User Interface Tab

Provides general user interface configurations.

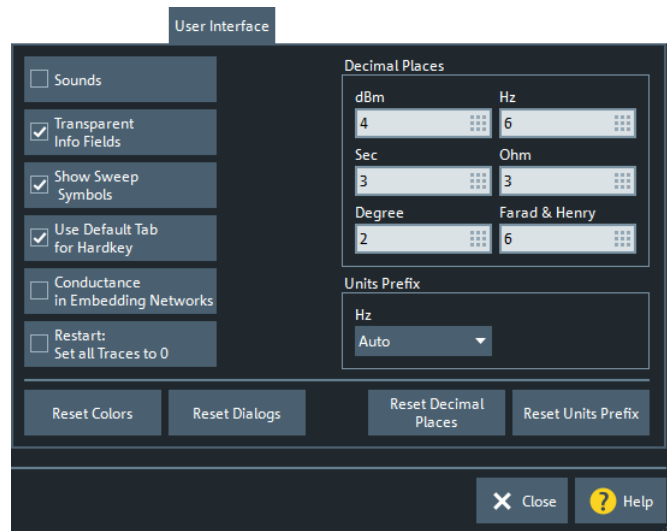
**Sounds**

Switches the sounds generated by the analyzer GUI on or off. Sounds are generated for certain GUI events, when the analyzer generates a notice, status or warning message (alarm sounds) or during calibration.

Limit fail beeps for [limit tests](#), [ripple tests](#), and [circle tests](#) is not affected by this setting. If enabled, those beeps are generated even if "Sounds" is unchecked.

These sounds are generated using the built-in sound chip and loudspeaker of the R&S ZND.

Remote command:

`SYSTem:SOUNd:ALARm[:STATe]`

`SYSTem:SOUNd:STATus[:STATe]`

Transparent Info Fields

This checkbox enables or disables transparent info fields for markers and trace statistics.

Transparent info fields do not hide an underlying trace.

Remote command:

n.a.

Show Sweep Symbols

This checkbox turns sweep symbols on or off.

Sweep symbols are arrows pointing downward onto the trace. They are displayed if the sweep time exceeds an upper limit, e.g. if the number of points is high or the measurement bandwidth is low.

Remote command:

n.a.

Use Default Tab for Hardkey

If the checkbox is selected (system default), the [Function Keys](#) activate the first enabled tab of their associated softtool. Otherwise the last used tab is activated.

For background information, see [Chapter 6.1, "Function Keys and Softtools"](#), on page 219.

Remote command:

n/a

Conductance in Embedding Networks

Changes the presentation of "capacitance C<i> in parallel with resistance R<i>" circuit blocks in lumped de/embedding networks (see [Chapter 5.6.2.3, "Circuit Models for 2-Port Networks"](#), on page 181 and [Chapter 5.6.2.4, "Circuit Models for 4-Port Networks"](#), on page 182).

If active, the resistance R<i> is displayed and specified as conductance G<i> ($=1/R<i>$).

Remote command:

`SYSTem:DISPlay:CONDUCTancesn/a`

Restart: Set all Traces to 0

Defines the behavior of the "Restart Sweep" function (see ["Restart Sweep"](#) on page 371).

If unchecked (factory default) the previous measurement data are preserved. If checked, they are deleted.

Remote command:

`SYSTem:TRESet[:STATe]` on page 1055

Number of Trace Colors

Defines the maximum number of trace colors (trace properties for the [user defined color scheme](#)).

Remote command:

`SYSTEM:DISPLAY:TRACes:CCOunt`

Decimal Places

Defines the number of fractional digits for quantities with different physical units. The settings affect entries and results, e.g. the values in the marker lists.

Note: If your instrument is equipped with option R&S ZND-K19, 1 mHz Frequency Resolution, set "Decimal Places" of unit "Hz" to 12 to utilize the high frequency resolution.

Remote command:

n/a

Units Prefix

Sets the unit prefix for frequencies (Base unit: Hz) to kilo (k), mega (M), giga (G) or tera (T) or lets the R&S ZND select the appropriate prefix ("Auto" = default setting).

Remote command:

n/a

Reset Colors / Reset Dialogs / Reset Decimal Places / Reset Units Prefix

Resets the color settings ("System" > "Display" < "Config"), the dialog properties, the "Decimal Places" and the "Units Prefix" settings. These settings are global and not affected by an instrument preset.

Remote command:

n/a

Messages Tab

Defines which instrument events are indicated by an information popup.

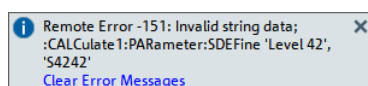

Display of information popups can be globally disabled or limited to certain event types.

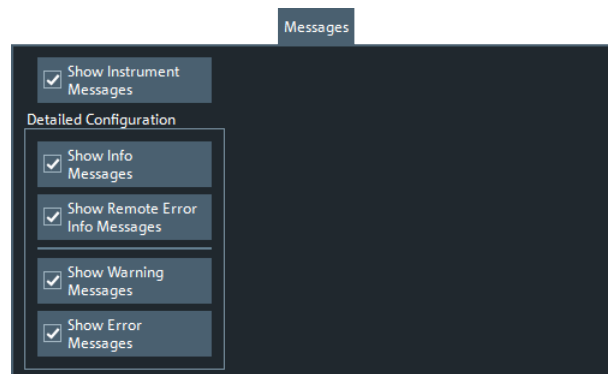

Show Instrument Messages

Defines whether information popups are displayed at all.

Remote command:

```
SYSTem:ERRor:DISPlay:STATe
```

Show Info Messages / Show Warning Messages / Show Error Messages

Selectively disables/enables display of information popups for the related event type.

If information popups are globally switched off ([Show Instrument Messages](#) unchecked), these buttons are disabled. However, their checked state is memorized.

Remote command:

```
SYSTem:ERRor:DISPlay:INFO
```

```
SYSTem:ERRor:DISPlay:WARNings
```

```
SYSTem:ERRor:DISPlay:ERRor
```

Show Remote Error Info Messages

Defines whether information popups are displayed whenever a remote control command error occurs.

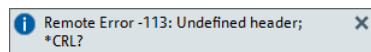

The displayed information can be useful for program development and optimization; it does not necessarily indicate that a remote control script is faulty or non-executable.

Note

- If either "Show Instrument Messages" or "Show Info Messages" is unchecked, this button is disabled. However, its checked state is memorized.
- For SCPI error -113, Undefined header, no tooltip is displayed.

Remote command:

```
SYSTem:ERRor:DISPlay[:REMote]
```

Channel Bits Tab

Sets a channel-dependent 8-bit decimal value (0, ..., 255) to control eight independent output signals at the USER PORT connector (lines 8 to 11 and 16 to 19).

Setting the channel bits does not change the analyzer state.

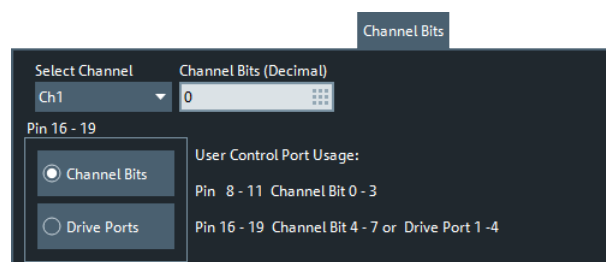

Channel Bits (Decimal)

Entry of the 8-bit decimal value (0 ... 255) for the selected channel. The channel bits control eight output signals at the USER PORT connector. The signals are 3.3 V TTL signals which can be used to differentiate between up to 256 independent analyzer states. For an application example, refer to the description of the remote-control command.

The decimal values have the following effect:

- 0 means that no output signals are enabled at any of the pins 8, 9, 10, 11 and 16, 17, 18, 19.
- 1 enables the output signal at pin 8. The signal is switched on while a measurement sweep is running in the selected channel. All other signals are inactive.
- 2 enables the output signal at pin 9.
- 3 enables the output signals at pins 8 and 9.
- ...
- 255 enables the output signals at all pins. See also "[Pin 16 - 19](#)" on page 526.

Remote command:

`OUTPut<Ch>:UPORT[:VALue]`

Pin 16 - 19

Selects the control mechanism for the signals at pins 16 to 19 of the USER PORT connector.

- **"Channel Bits"**: Signals are controlled by channel bits 4 to 7. No drive port indication at the USER PORT connector.
- **"Drive Ports"**: Signals indicate the active drive ports. The number of active channel bits is reduced to 4 (pins 8 to 11).

Remote command:

`OUTPut:UPORT:ECBits`

Advanced Tab

Collects several advanced settings.

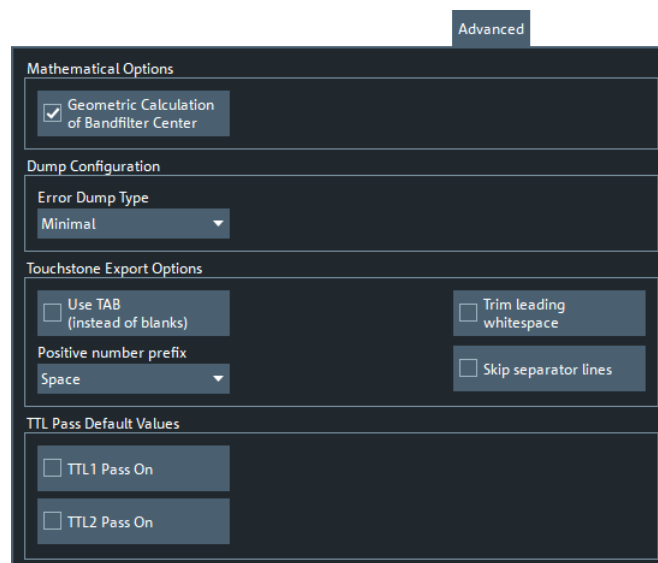

Geometric Calculation of Bandfilter Center

Defines how bandfilter searches calculate the center frequency of the passband or stopband (see ["Bandfilter Search"](#) on page 89).

If "Geometric Calculation of Bandfilter Center" is checked, the *geometric mean* of the lower band edge and upper band edge frequencies is used, otherwise their *arithmetic mean*.

Remote command:

```
CALCulate:MARKer:FUNCTion:BWIDth:GMCenter
```

Error Dump Type

Determines the level of detail ("Minimal", "Normal", "Large", "Full") and hence the size of the dump files that are created if a firmware exception occurs. "None" disables dump file creation.

The latest 5 exception dumps can be retrieved using the "Save Report" function of the "Info" dialog (see ["Create R&S Support Information"](#) on page 534).

For further information, see [Chapter 10, "Error Messages and Troubleshooting"](#), on page 1143.

Remote command:

```
DIAGnostic:DUMP:SIZE
```

Touchstone Export Options

Configures whitespace insertion during legacy [Version 1.1 \(ZNx\)](#) Touchstone file export.

The default export format is explained in [Chapter 5.4.2.1, "Touchstone Files"](#), on page 130:

- logical columns are vertically aligned using spaces
- positive and negative numbers are vertically aligned by prefixing positive numbers with blanks
- the frequencies are horizontally separated from the corresponding S matrices using leading spaces
- the content parts (header, S matrices for different frequencies) are separated by blank lines

Use TAB (instead of blanks) ← Touchstone Export Options

If checked, columns are separated by tabs rather than spaces.

Remote command:

```
MMEMory:STORe:TRACe:OPTion:TABS
```

Trim Leading Whitespace ← Touchstone Export Options

If checked, whitespace at the beginning of each line is removed.

Remote command:

```
MMEMory:STORe:TRACe:OPTion:TRIM
```

Positive Number Prefix ← Touchstone Export Options

Positive numbers can either be prefixed by blanks, by plus signs or not at all.

Remote command:

```
MMEMory:STORe:TRACe:OPTion:PLUS
```

Skip Separator Lines ← Touchstone Export Options

If checked, the content parts are no longer separated by blank lines.

Remote command:

```
MMEMory:STORe:TRACe:OPTion:SSEParator
```

TTL Pass Default Values

Defines the default values of [TTL1 Pass](#) / [TTL2 Pass](#) for new traces.

Remote command:

```
SYSTem:TTLout<Pt>:STATus[:STATE]
```

Power Tab

The settings in this tab define global power settings of the VNA.

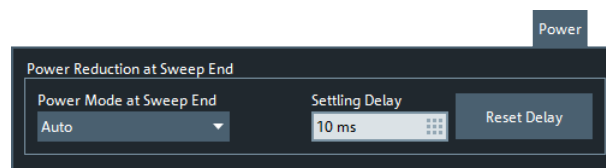

Power Reduction at Sweep End

The power reduction settings apply to all sweep modes but are particularly useful in single sweep mode.

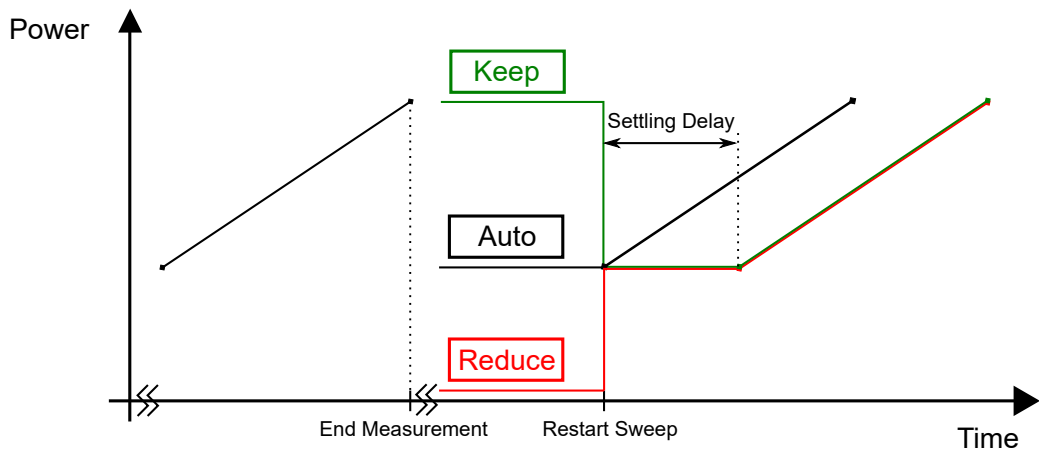

Figure 6-34: Power control at sweep end in Single Sweep mode (power sweep)

Note: By default, at sweep end the output power of the first measurement point is restored ("Auto" mode). After a small settling time (~10 ms), the sweep can be restarted.

Selecting a different behavior can result in a significantly longer total measurement time, in particular if a long "Settling Delay" is used. Do not forget to revert the [Power Mode at Sweep End](#) to "Auto" mode if it is not necessary to "Reduce" or "Keep" the power at the sweep end. A preset is not sufficient for this purpose.

Power Mode at Sweep End ← Power Reduction at Sweep End

The analyzer offers three power modes at sweep end:

- "Auto" results in the shortest measurement time (default setting). If enabled, at sweep end the output power of the first measurement point is restored. The configured [Settling Delay](#) is not applied.
- "Reduce" is intended for measurements on sensitive DUTs (primarily: power sweeps). If enabled, at sweep end the output power of the driving port is reduced as if the channel base power was set to its minimum possible value. The configured settling delay is applied.
- "Keep" is intended for power sweeps. If enabled, at sweep end the output power of the last measurement point is kept. The configured settling delay is applied.

See [Figure 6-34](#) for an illustration.

Note:

- Compared to "Auto" mode, "Reduce" and "Keep" can result in significantly longer measurement times - in particular if an extended settling delay is used.
- The output power is not altered if there is only a single channel with a single driving port, performing a "Time" or "CW Mode" sweep.
- In triggered mode, the analyzer always uses the settings of the first measurement point while waiting for the trigger signal.

Remote command:

```
SOURce:POWer:SWEepend:MODE
```

Settling Delay / Reset Delay ← Power Reduction at Sweep End

If [Power Mode at Sweep End](#) is set to "Reduce" or "Keep", the "Settling Delay" defines the time between [Restart Sweep](#) request and sweep start. See [Figure 6-34](#) for an illustration.

Use the "Reset Delay" button to adjust the "Settling Delay" to its default value.

Remote command:

```
SOURce:POWer:SWEepend:SDELay
```

Recovery Tab

Provides a single function "Boot into Recovery Screen" that allows you reboot the instrument and launch the "R&S Recovery Environment". From there you can restore the original system image (including operating system and firmware).

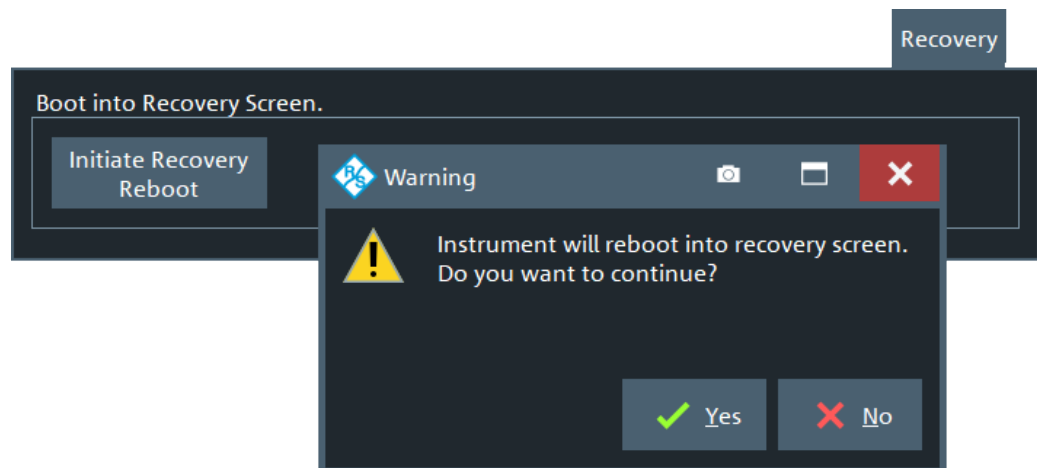

See [Chapter 11.2, "System Recovery"](#), on page 1155.

HUMS Tab

The "HUMS" tab allows you to enable and configure R&S HUMS (see [Chapter 5.7.12, "Health and Usage Monitoring Service \(HUMS\)"](#), on page 205). It is only available if software option R&S ZND-K980 is installed.

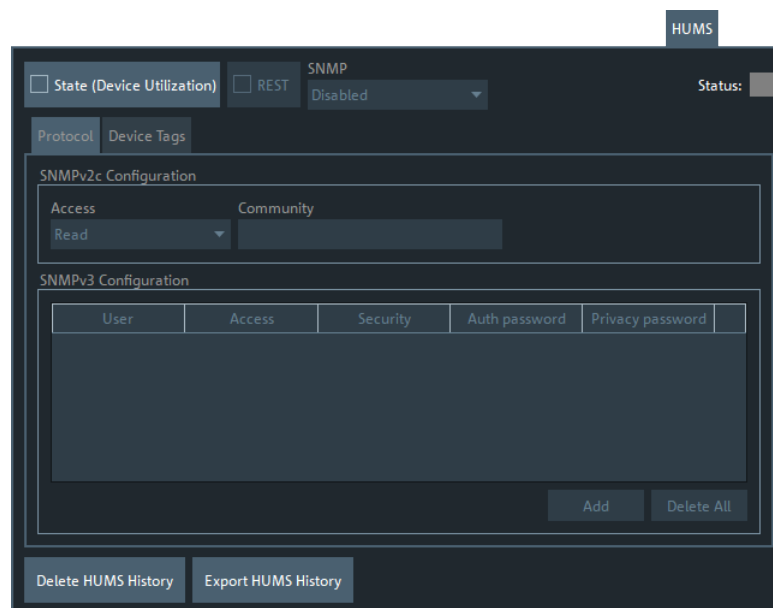

Common Controls

State (Device Utilization)/Status

Enables/disables the HUMS service.

The "Status" LED indicates the current state of the HUMS service:

- grey: inactive
- green: up and running

If HUMS has been used before, turning on restores the previous [protocol settings](#).

Remote command:

`DIAGnostic:HUMS:STATE`

REST ← State (Device Utilization)/Status

Enables/disables the **REST** interface to the HUMS service.

Remote command:

`SYSTEM:COMMunicate:REST:ENABLE`

SNMP ← State (Device Utilization)/Status

Enables/disables the **SNMP** interface to the HUMS service and allows you to select the supported SNMP protocol versions.

Depending on the enabled versions, different parts of the **Protocol Subtab** are enabled.

Note: If you activate v2c, version v1 is also active.

Remote command:

`SYSTEM:COMMunicate:SNMP:VERSION`

Delete HUMS History

Allows you to delete the previously collected health and monitoring information from the instrument.

Remote command:

`DIAGnostic:HUMS:DELETE:ALL`

Export HUMS History

Allows you to export the previously collected health and monitoring information to a zipped JSON file.

Remote command:

`DIAGnostic:HUMS:DELETE:ALL` on page 1073

Protocol Subtab

Gives access to SNMP configuration options for protocol version 2c and 3.

SNMPv2c Configuration

Allows you to grant read or read-write access via SNMPv2c, and to specify the related community string.

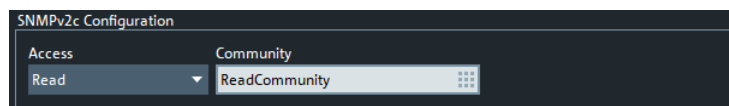

An SNMP community represents a collection of devices and agents grouped to monitor them. Authorized managers and the managed devices belong to an SNMP community. You can specify different communities for read-write and read-only access.

Remote command:

`SYSTEM:COMMunicate:SNMP:COMMunity:RO`

`SYSTEM:COMMunicate:SNMP:COMMunity:RW`

SNMPv3 Configuration

Allows you to enable and configure the SNMPv3-specific authentication and privacy features (passwords for access security and data encryption).

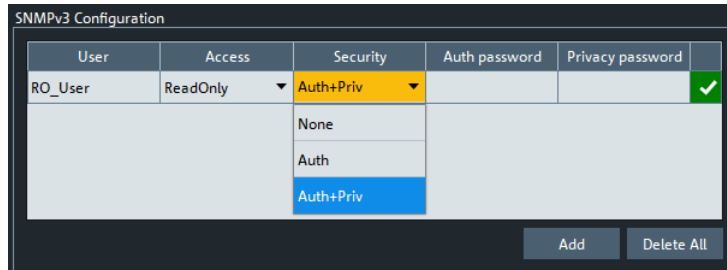

- To add a new user, select the "Add" button, enter the data and create the user by selecting the "✓" icon.
- To delete a single user, select the trash icon in the corresponding row.
- To delete all users, select the "Delete All" button.

Remote command:

```
SYSTEM:COMMunicate:SNMP:USM:USER:ALL?
SYSTEM:COMMunicate:SNMP:USM:USER
SYSTEM:COMMunicate:SNMP:USM:USER:DElete
SYSTEM:COMMunicate:SNMP:USM:USER:DElete:ALL
```

Device Tags Subtab

Allows you to manage key-value pairs for HUMS device tagging.

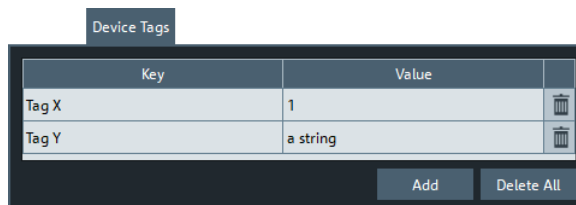

A device tag is a label to assign to your instrument. You can create any device tag for your instrument and define it by a specific key and value.

Add / Delete (Trash) / Delete All

- To add a new device tag, select the "Add" button and enter the "Key" and "Value strings".
The "Key" must be unique.
- To delete a single device tag, select the trash icon in the corresponding row.
- To delete all device tags, select the "Delete All" button.

Remote command:

```
DIAGnostic:HUMS:TAgS:ALL?
DIAGnostic:HUMS:TAgS[:VALue]
DIAGnostic:HUMS:TAgS:DElete
DIAGnostic:HUMS:TAgS:DElete:ALL
```



6.17.1.3 Info Dialog

The "Info" dialog displays information about the instrument and its operation. All functions are primarily intended for error diagnostic and service purposes; see [Chapter 10.3, "Collecting Information for Technical Support"](#), on page 1146. Many "Info" tabs also display softkeys for printing the contents or saving them to a file.

Access: SYSTEM – [SETUP] > "Setup" > "Info..."

Common Controls in the Info Dialog

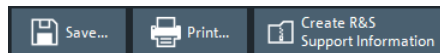
The "Save...", "Print...", and " Save Report" buttons at the bottom of the "Info" dialog allow you to save the contents of the open tab to a file or to create a hardcopy.



Save...

Allows you to save the contents of the open tab to an HTML file.

Remote command:

`DIAGnostic:DEVIce:STATe`

`SYSTem:DFPPrint?`

Print...

Allows you to print the contents of the open tab. Opens a "Print Preview" dialog for printer and paper setup.



Create R&S Support Information

Saves the current selftest results to a zipped report file you can send to R&S Support for fault diagnosis; see [Chapter 10.3, "Collecting Information for Technical Support"](#), on page 1146.

Remote command:

```
DIAGnostic:DEVIce:STATe
SYSTem:DFPRint?
```

Setup Tab

Displays the channel and trace settings of the active recall set and the main characteristics of the instrument, including its IP address.



Options Tab

Shows the installed software and hardware options. You can also enable additional software options using the option key supplied with the option. Proceed according to the instructions in the dialog.

For an overview of options, refer to [Chapter 5.7, "Optional Extensions and Accessories"](#), on page 191.

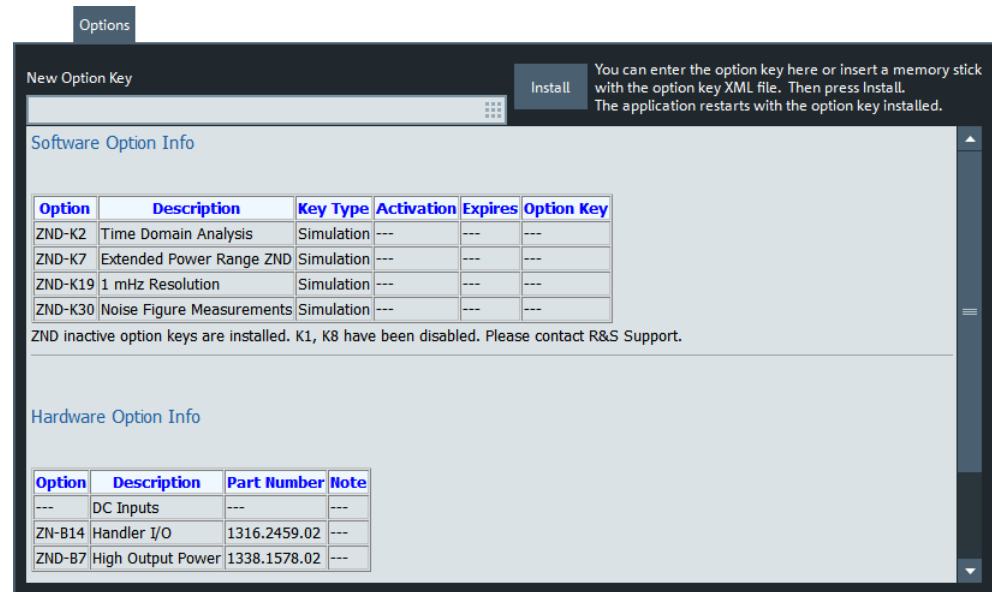

Software Option Info

Software options are listed with their name and description, the option key and key type, and the activation and expiration date (if applicable).

Remote command:

`DIAGnostic:PRODUct:OPTion:INFO?`

Hardware Tab

Gives an overview of the analyzer's hardware configuration and basic hardware-related instrument settings.

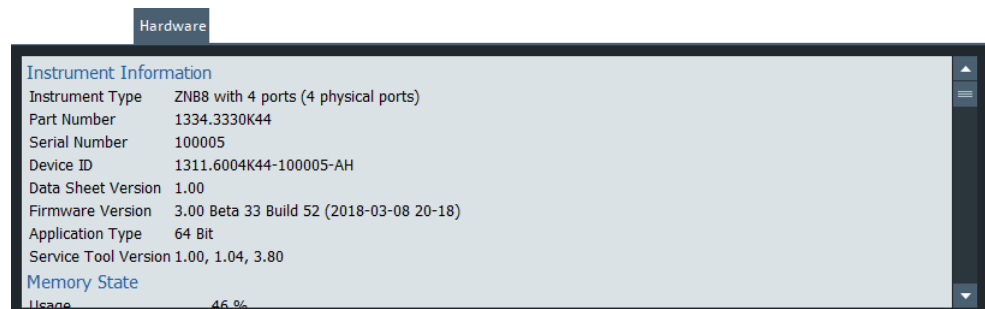

Configured External Switch Matrices

The "Hardware" tab also provides information about connected switch matrices. In particular, for mechanical matrices the current relay switch counts are reported (if supported by the matrix).

Remote command:

`SYSTem:COMMunicate:RDEvice:SMATrix<Matr>:RELAys:SWITCh:COUNT?`

Selftest Tab

Allows to run an automatic selftest on the analyzer, and to displays its results. Check "Show Details" to see the detailed test results.

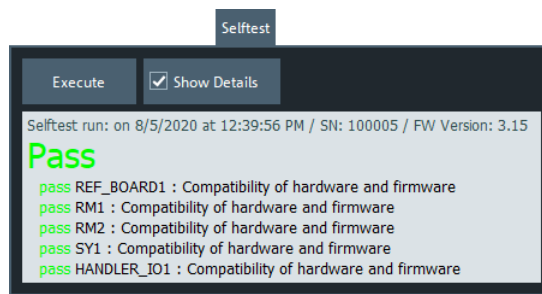

Error Log Tab

Contains a chronological record of errors that occurred in the current and in previous sessions (see [Chapter 10.1, "Errors during Firmware Operation"](#), on page 1143).

The "Error" tab comes with an additional button for clearing the log ("Delete Error Log").

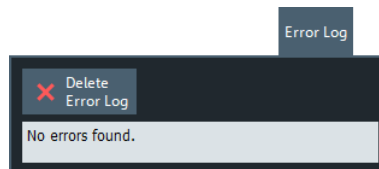

Cal Validation Tab

Displays the result of the last cal validation. See "[Cal Validation ...](#)" on page 375.

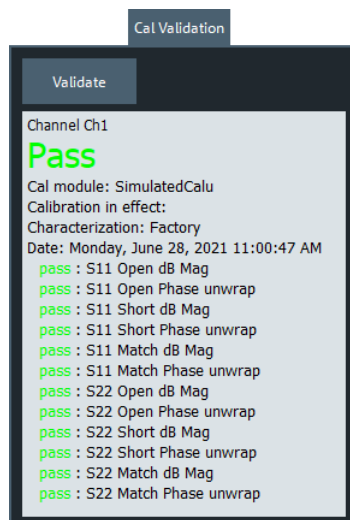

Service Tab

Allows you to read or specify service-related information. This information can be read via [R&S HUMS](#), however, it does not require the corresponding option R&S ZND-K980.

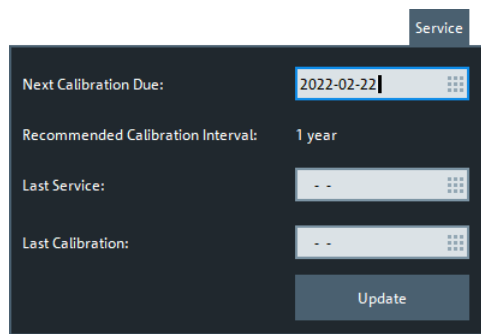

Next Calibration Due

The date (and time) the instrument needs calibration to be done.

Remote command:

```
DIAGnostic:SERvice:CALibration:DUE:DATE
```

Recommended Calibration Interval

Queries the recommended calibration interval, set by Rohde&Schwarz service.

Remote command:

```
DIAGnostic:SERvice:CALibration:INTERval?
```

Last Service

The last date (and time) the instrument was serviced.

Typically set by Rohde&Schwarz service.

Remote command:

```
DIAGnostic:SERvice:DATE
```

Last Calibration

The last date (and time) the instrument was calibrated.

Typically set by Rohde&Schwarz service.

Remote command:

```
DIAGnostic:SERvice:CALibration:DATE
```

6.17.1.4 Service Function Dialog

The "Service Function" dialog gives access to the service functions of the instrument.

Access: [SETUP] > "Setup" > "Service Function..."

Most of the service functions require a service level > 0 that is protected by a password. Those service functions should be used by a Rohde & Schwarz service representative only. Refer to the service manual for more information.

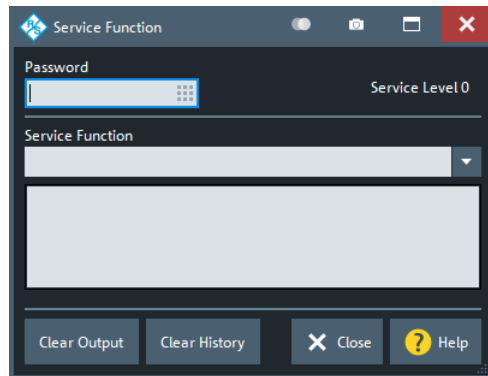

Password

Enter a password here to activate the required service level.

Remote command:

`SYSTEM:PASSWORD[:CENable]`

Service Function

Identifier of the service function in "dotted textual" (example: sw.common.memory_usage) or "dotted decimal" (example: 0.1.18.0) representation.

Remote command:

`DIAGNOSTIC:SERVICE:SFUNCTION`

6.17.2 Freq. Ref. Tab

Selects a reference signal for synchronization between the R&S ZND and external devices. A common reference frequency is advisable to ensure frequency accuracy and frequency stability in the test setup.

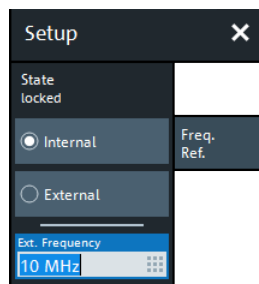

State

Indicates the state of the internal phase locked loop: If the frequencies are properly synchronized, the state is "locked".

Remote command:

n/a

Internal/External

Selects the internal or an external reference clock signal for synchronization.

- **Internal:** The analyzer synchronizes to its internal 10 MHz reference clock.

Use the REF OUT connector at the rear of the instrument to synchronize other devices (e.g. signal generators or a second R&S ZND network analyzer).

- **External:** The analyzer synchronizes to an external reference clock via the REF IN connector at the rear of the instrument.

The external reference signal has to meet the specifications of the data sheet; its frequency must be specified in the "Ext Frequency" field. The internal reference signal is synchronized to the external signal. The external signal is also looped to REF OUT, so that it can be reused to synchronize other devices.

Remote command:

```
[SENSe<Ch>:]ROSCillator[:SOURce]
```

Ext Frequency

Specifies the frequency of the external reference clock signal at REF IN.

Remote command:

```
[SENSe:]ROSCillator:EXTernal:FREQuency
```

6.17.3 Remote Settings Tab

Configures the remote control interfaces of the R&S ZND.

6.17.3.1 Controls on the Remote Settings Tab

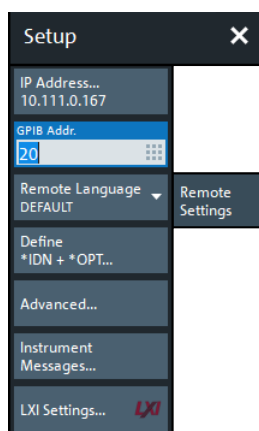

IP Address

Displays the current IP4 address of the R&S ZND. By default, the analyzer is configured to use dynamic TCP/IP configuration (DHCP) and obtain all IP address information automatically. See [Chapter 11.1.3.1, "Assigning an IP Address"](#), on page 1151.

The button opens the Windows "Network Connections" system config dialog that allows you to configure the IP4 (and IP6) settings of your instrument.

GPIB Address

Defines the analyzer's GPIB address. The address must be in the range between 0 and 30.

Remote command:

```
SYSTem:COMMunicate:GPIB[:SELF]:ADDRESS
```

```
SYSTem:COMMunicate:GPIB[:SELF]:DClear:SUPPress
```

Remote Language

Selects the syntax of the R&S ZND's instrument control commands.

- The DEFAULT language corresponds to the commands reported in this documentation; see [Chapter 8.3, "SCPI Command Reference"](#), on page 597.
- The ZVABT language ensures compatibility with network analyzers of the R&S ZVA/B/T family. E.g., compared to the DEFAULT language, the command set does not include `INITiate:CONTinuous:ALL` and `INITiate[:IMMediate]:ALL`. The function of `INITiate:CONTinuous` and `INITiate[:IMMediate][:DUMMy]` is modified; refer to the remote control documentation in [Chapter 8.3.8, "INITiate Commands"](#), on page 835.
- The ZVR language ensures compatibility with network analyzers of the R&S ZVR family. See also [Chapter 8.5, "R&S ZVR/ZVABT Compatible Commands"](#), on page 1087.
- PNA, ENA, HP8510, HP8720, HP8753 ... denote command sets for network analyzers from other instruments or manufacturers.

Note: Remote languages other than DEFAULT are intended for remote control of the analyzer. A mixed approach, with part of the instrument configuration defined via the GUI, is possible but can cause unexpected results in some instances.

Remote command:

```
SYSTem:LANGuage
```

Define *IDN + *OPT...

Defines a format for the ID string and the option string of the analyzer. The default strings are automatically adjusted to the selected "Remote Language". The strings can be queried via `*IDN?` and `*OPT?`, respectively.

- If the DEFAULT language is activated, the factory ID string *Rohde&Schwarz,ZND-<Ports>Port,<Order and Serial No>,<FWVersion>* (e.g. *Rohde-Schwarz,ZND-2Port,131160041212345,1.10.05*) is set. The option string is a comma-separated list of all installed software and hardware options. The bit order for transferred binary data is swapped (`FORMat:BORDER SWAPped`).
- If the PNA language is activated, Keysight-compatible ID and option strings are set. The bit order for transferred binary data is normal.
- If one of the "HP xxxx" languages is activated, "HP xxxx"-compatible ID and option strings are set. Binary data is transferred in a device-specific bit order, however, the bit order can be changed using "HP xxxx"-specific commands.

The ID and option strings can be changed or reset to the R&S factory ID string.

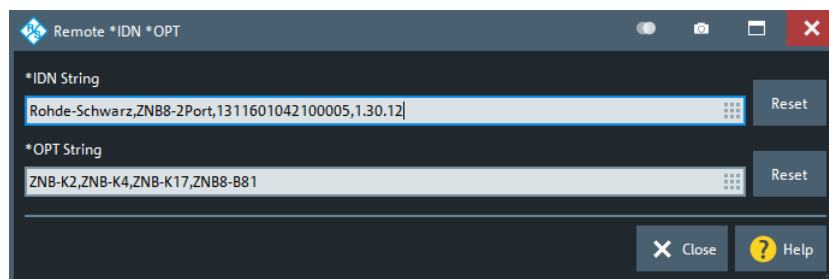

Remote command:

```

SYSTEM:IDENTify[:STRing]
SYSTEM:IDENTify:FACTory
SYSTEM:OPTions[:STRing]
SYSTEM:OPTions:FACTory
FORMat:BORDER

```

Advanced ...

Opens a dialog that allows to set the following parameters:

- "Wait for Data after Sweep" determines the execution behavior of `INITiate[:IMMEDIATE]` commands (see [Chapter 8.3.8, "INITiate Commands"](#), on page 835).
If enabled, an automatic `*WAI` is added (see [Chapter 8.2, "Common Commands"](#), on page 596).
By default this is disabled.
- "Auto-Align Logical Ports" determines the logical port creation logic.
If enabled (default), logical ports are aligned and must be set from low to high port (which was the only possibility prior to firmware V1.91). If set to disabled, new ports can be created freely, like in manual operation.
- "No Device Clear" suppresses Device Clear (DCL, SDC) GPIB interface messages.

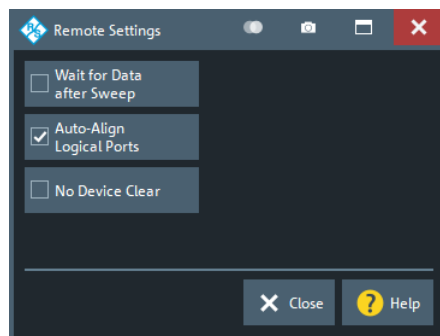

Remote command:

```

SYSTEM:COMMunicate:GPIB[:SELF]:INIT:WAIT
SYSTEM:COMMunicate:GPIB[:SELF]:LPORT:ALIGn
SYSTEM:COMMunicate:GPIB[:SELF]:DCLear:SUPPpress

```

Instrument Messages...

Opens the System Configuration dialog with the [Messages Tab](#) selected. From there you can configure the display of instrument messages as information popups, in particular the display of remote control command errors.

6.17.4 External Devices Tab

Allows you to set up and configure external power meters and calibration units and to enable error logging for the current session.



Background information

Refer to the following sections:

- [Chapter 5.7.19, "External Power Meters"](#), on page 208
- [Chapter 5.5.5, "Automatic Calibration"](#), on page 159

6.17.4.1 Controls on the External Devices Tab



The buttons in the "External Devices" panel open the following dialogs:

- "Power Meters...", see [Chapter 6.17.4.2, "External Power Meters Dialog"](#), on page 543
- "Power Meter Config...", see [Chapter 6.17.4.3, "External Power Meter Config Dialog"](#), on page 546
This button is active only if at least one external power meter is online (physically connected, switched on, ready to be used).



Switch matrices can be configured on the "External Ports" tab, see [Chapter 6.17.5.2, "External Matrices Dialog"](#), on page 548 and [Chapter 6.17.5.4, "Switch Matrix RF Connections Dialog"](#), on page 552.



Remote control via GPIB

The R&S ZND-B10 can be used control external devices via GPIB. An additional [USB-to-IEC/IEEE Adapter](#) is only required in case you want to control the R&S ZND via GPIB at the same time.

Log Errors

Enables the transfer of error messages for external devices (e.g. connection errors) to the error log. The error log appears in the "Info" dialog; see [Chapter 6.17.1.3, "Info Dialog"](#), on page 533.

Remote command:

n/a

6.17.4.2 External Power Meters Dialog

The "External Power Meters" dialog configures external power meters so that they can be used for measurements and power calibrations.

Access: SYSTEM – [SETUP] > "External Devices" > "Power Meters..."



Background information

Refer to section [Chapter 5.7.19, "External Power Meters"](#), on page 208.

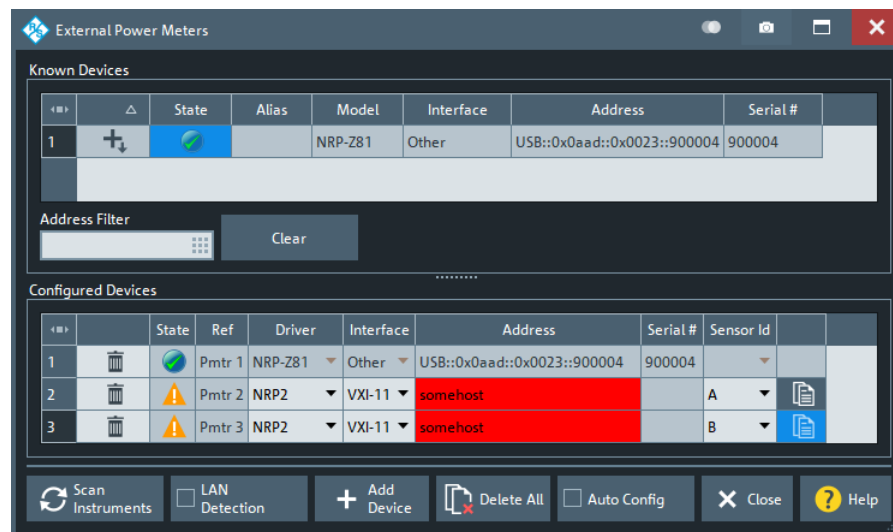

The configuration of a new external power meter involves the following steps:

1. Connect the power meter to your R&S ZND using a LAN (VXI-11), GPIB, or USB interface.
2. If the power meter is connected via LAN, enable [LAN Detection](#)
3. Select [Scan Instruments](#) and wait until the power meter appears in the table of "Known Devices".
4. Select \uparrow to add the power meter to the list of [Configured Devices](#).

If the R&S ZND fails to detect a connected power meter:

- ▶ Select [Add Device](#) to define the interface type and address.

The R&S ZND can auto-detect the instrument type (driver) and the serial number of the connected power meter.



To control external devices via GPIB, the pre-installed RS Visa library (`visa32.dll`) must be replaced by the **NI Visa** library.

Known Devices

Table with all power sensors/meters the analyzer detects to be on line (i.e. connected and switched on). "Scan Instruments" refreshes the table.

Select  to add a power sensor/meter to the table of [Configured Devices](#).

Note: Even though an R&S NRP2 power meter can appear in the table of "Known Devices", adding it to the list of "Configured Devices" directly results in an invalid configuration. Use [Add Device](#) to configure it manually instead.

Remote command:

n/a

Configured Devices

Table with all power meters in use with their properties.



Except for the auto-detected [Known Devices](#), to appear in the table of "Configured Devices" a power sensor/meter must have been configured manually using [Add Device](#). The properties of manually configured power meters ([Add Device](#)) can be changed in the table cells.

The **"Sensor Id"** column is used for power meters that can control several power sensors, such as the R&S NRP2. By selecting the suitable "Sensor Id", you can address the related power sensor.

The R&S NRP2, for example, has four power sensor connectors, Sensor A to Sensor D. By selecting "A", "B", "C", or "D" you can address the power sensor that is attached to this connector.

Use the  icon beneath the "Sensor Id" cell to take control over another power sensor attached to the same power meter.

The following symbols (grayed out for *used* devices) indicate the status of the respective device:

-  – The device is online (connected, switched on, ready to be used).
-  – There is a problem with the device.
This state can be caused by different problems:
 - General communication error
In this case, check whether the device is properly connected to the configured interface.
 - Self test error
In this case enable error logging for external devices (see ["Log Errors"](#) on page 542), and search the [Error Log Tab](#) for self test error codes of the device.
-  – The device driver does not match exactly the device type. Probably the device cannot be controlled properly. Measurements results are questionable.

Remote command:

```
SYSTem:COMMunicate:RDEvice:PMETer<Pmtr>:DEFine
```

```
SYSTem:COMMunicate:RDEvice:PMETer:DELeTe
```

```
SYSTem:COMMunicate:RDEvice:PMETer:CATalog?
```

```
SYSTem:COMMunicate:RDEvice:PMETer:COUNT?
```

Scan Instruments

Performs an autodetection of "Known Devices" on the supported interfaces.

Note: Unintentional switchover to remote control

When using the NI-VISA library, ensure that the network analyzer itself is not listed as a network device in the Measurement & Automation Explorer. Otherwise, "Scan Instruments" initiates an identification query (*IDN?), causing the analyzer to close the "External Power Meters" dialog (without executing "Scan Instruments") and to activate the remote screen.

Remote command:

n/a

LAN Detection

Activate "LAN Detection" to include the LAN interface in the autodetection sequence (see [Scan Instruments](#)).

Note: "LAN detection" only works for external devices on the IP subnet with the R&S ZND.

As a prerequisite, the R&S ZND must accept incoming connections on UDP port 2473. If necessary, add a corresponding inbound rule to your firewall settings.

Remote command:

n/a

Add Device

Adds a new instrument to the list of "Configured Devices".

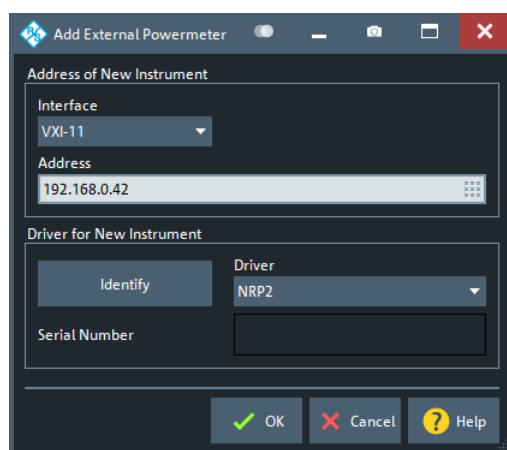

In the "Add External Power Meter" dialog, you can specify the instrument and connection properties:

- "Interface" selects an interface/protocol type for the connection. In addition to the GPIB, VXI-11 and SOCKET interface types, the analyzer accepts any "Other" interface supported by the installed VISA library. The former is applicable for devices connected to the GPIB Bus or LAN connectors on the rear panel of the analyzer, respectively. "Other" is used in particular for USB connections, e.g. for auto-detected R&S NRP-Zxx sensors.
- "Address" contains the address for the current interface type. GPIB addresses must be unique for all devices connected to the GPIB bus (range: 0 to 30), GPIB and IP addresses must agree with the entries in the VISA library. The remaining interface types require composite address formats; see [Table 6-5](#).

If an instrument is connected to the R&S ZND, the entries in the [Driver for New Instrument] panel can be auto-detected for the specified interface type and address.

- "Identify" sends an identification query ("IDN?") to the specified device address to identify the type and serial number of the connected power meter and select an appropriate driver file. Power meter driver files (*.pwm) are stored in the Resources\ExtDev subdirectory of the analyzer's program directory.

Table 6-5: Interface types for external power meters and address formats

Physical interface (connector)	Interface (protocol)	Address	Remarks
LAN	VXI-11	<IpAddress> for example 10.11.12.13	Full VISA resource string: TCPIP[board]::<Address>[::INSTR]
	SOCKET	<IpAddress>::<PortNo> for example 10.11.12.13::50000	LAN connection with pure TCP/IP protocol; refer to your VISA user documentation.
GPIB	GPIB0 ... GPIB9	<Address> for example 20	Full VISA resource string: GPIB[board]::<Address>[::INSTR]
LAN or USB	Other	Interface-specific, e.g. for SOCKET: TCPIP0::<IpAddress>::<PortNo>::SOCKET	Use complete VISA resource string.

Remote command:

```
SYSTem:COMMunicate:RDEvice:PMETer<Pmtr>:DEFine
```

Auto Config

Causes the analyzer to clear the lists of "Known Devices" and "Configured Devices" and to configure all R&S NRPxxS/SN power sensors, detected at any of the USB ports, automatically. No manual configuration is required.

Remote command:

```
SYSTem:COMMunicate:RDEvice:PMETer:CONFigure:AUTO[:STATe]
```

6.17.4.3 External Power Meter Config Dialog

Allows to modify configuration of certain external power meters, i.e. settings that are persistently stored on the power meter (and NOT on the R&S ZND). This requires the respective device to be online, i.e. connected, switched on and ready to be used.

Access: SYSTEM – [SETUP] > "External Devices" > "Power Meter Config..."

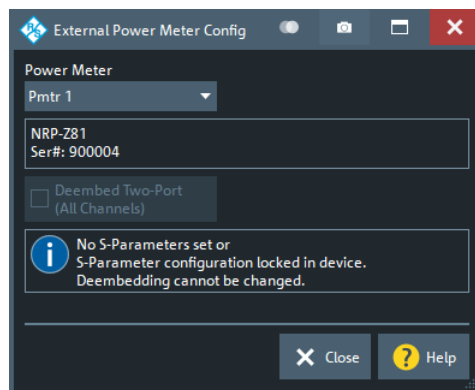

Deembed Two-Port (All Channels)

Reads and modifies the state of the built-in S-parameter correction that is available on certain R&S®NRP-Z power sensors. See Application Note 1GP70 "Using S-Parameters with R&S®NRP-Z Power Sensors" for background information. This Application Note is available on the Rohde & Schwarz internet at <http://www.rohde-schwarz.com/appnotes/1GP70>.

Remote command:

```
SYSTem:COMMunicate:RDEvice:PMETer<Pmtr>:SPCorrection[:STATe]
```

6.17.5 External Ports Tab

Allows you to set up switch matrices.



Background information

Refer to:

- [Chapter 5.7.20, "External Switch Matrices"](#), on page 210

6.17.5.1 Controls on the External Ports Tab

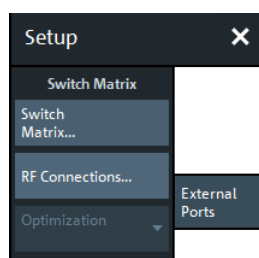

The buttons in the "External Ports" panel open the following dialogs:

- "Switch Matrix...", see [Chapter 6.17.5.2, "External Matrices Dialog"](#), on page 548
- "RF Connections...", see [Chapter 6.17.5.4, "Switch Matrix RF Connections Dialog"](#), on page 552

"RF Connections" is enabled if at least one switch matrix is configured.

Optimization

Allows you to select between different switch matrix routing optimizations:

- "Speed" – switch as little as possible
- "Precision" – always use the best possible route in terms of quality ("priority")

See [Chapter 5.7.20.4, "Multiple Paths: Precision vs. Speed"](#), on page 213 for background information.

The selection is only enabled, if at least one of the connected switch matrices has multiple routes with non-identical priorities.

6.17.5.2 External Matrices Dialog

The "External Matrices" dialog allows you to discover and register external switch matrices.

Access: SYSTEM – [SETUP] > "External Ports" > "Switch Matrix..."



Background information

Refer to section [Chapter 5.7.20, "External Switch Matrices"](#), on page 210.

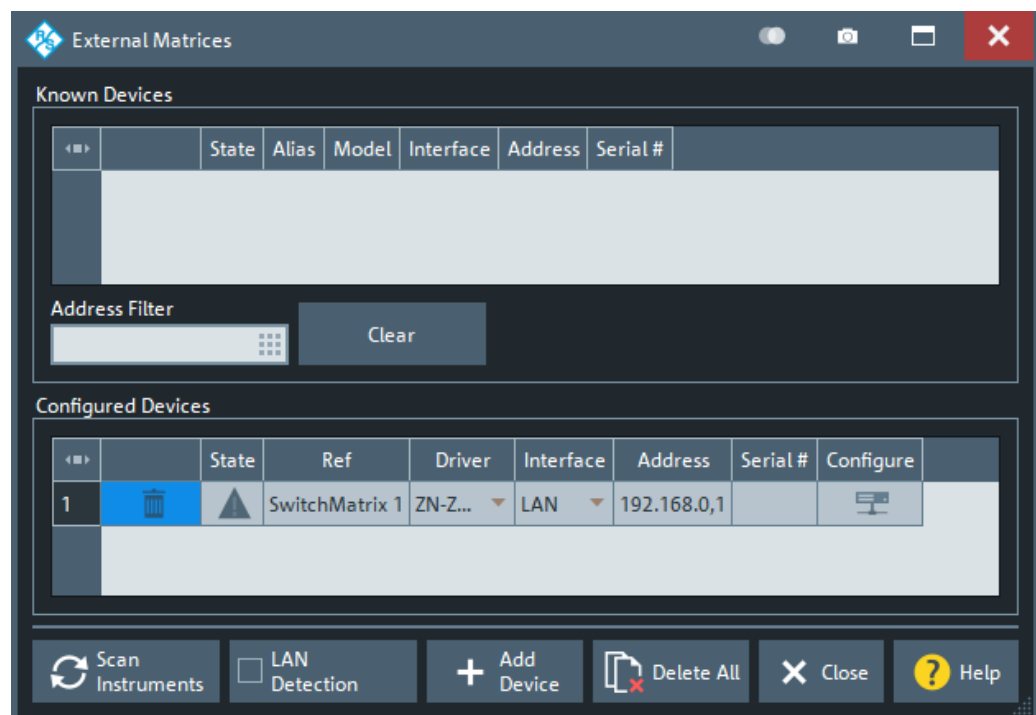

The registration of a new external switch matrix typically involves the following steps:

1. connect the switch matrix to your R&S ZND using LAN or USB interface.
2. If the switch matrix is connected via LAN, enable "LAN detection".
3. tap "Scan Instruments" and wait until the switch matrix appears in the table of "Known Devices".

4. tap  to copy the switch matrix to the list of configured devices.

If "LAN Detection" fails for some reason (see below for details), the external switch matrix can also be registered manually:

1. tap "Add Device" to open the "Add External Switchmatrix" dialog (see figure below).
2. In the "Add External Switchmatrix" dialog:
 - a) specify the IP address or hostname of the switch matrix.
 - b) tap "Identify" to auto-detect the matrix type ("Driver") of the remote switch matrix.
If the device cannot be identified (e.g. because it is temporarily unavailable), select the appropriate "Driver" manually.



Registering a switch matrix is only the first step. To make the external ports available to the vector network analyzer, the RF connections have to be configured, as described in [Chapter 6.17.5.4, "Switch Matrix RF Connections Dialog"](#), on page 552.

Known Devices

Table with the discovered switch matrices.

"Scan Instruments" refreshes the table;  copies a discovered switch matrix to the table of "Configured Devices".

Remote command:
n/a

Configured Devices

Table displaying the registered switch matrices.



A distinction is made between those switch matrices that are used in RF connections (see [Chapter 6.17.5.4, "Switch Matrix RF Connections Dialog"](#), on page 552) and those that are not.

- *Used* matrices are represented by inactive rows (grayed out).
- *Unused* matrices are represented by active table rows (colored).

For unused switch matrices that were manually registered via "Add Device", some properties can be changed by editing the corresponding table cells.

A matrix can always be unregistered using the  button of the respective row. This automatically deletes the related RF connections and renumbers the remaining test ports.

The following symbols (grayed out for *used* devices) indicate the status of the respective device:

-  – The device is online (connected, switched on, ready to be used).
-  – There is a problem with the device.
This state can be caused by different problems:
 - General communication error
In this case, check whether the device is properly connected to the configured interface.
 - Self test error

In this case enable error logging for external devices (see ["Log Errors"](#) on page 542), and search the [Error Log Tab](#) for self test error codes of the device.

-  – The device driver does not match exactly the device type. Probably the device cannot be controlled properly. Measurements results are questionable.

For matrices with LAN interface, the  button in the last column of the "Configured Devices" table opens the "Device LAN configuration" dialog which allows to read and modify their "IP Configuration" (see [Chapter 6.17.5.3, "Device LAN Configuration Dialog"](#), on page 551).

The related switch matrix must be **online** and connected via USB (and not via LAN interface). Otherwise the button is disabled.

Remote command:

```
SYSTem:COMMunicate:RDEvice:SMATrix:COUNT?
```

```
SYSTem:COMMunicate:RDEvice:SMATrix<Matr>:SERial?
```

Scan Instruments

Performs an autodetection of "Known Devices" on the supported interfaces.

Note: Unintentional switchover to remote control

When using the NI-VISA library, ensure that the network analyzer itself is not listed as a network device in the Measurement & Automation Explorer. Otherwise, "Scan Instruments" will send an identification query (*IDN?), causing the analyzer to close the "External Switch Matrix" dialog (without executing "Scan Instruments") and to activate the remote screen.

Remote command:

```
SYSTem:COMMunicate:RDEvice:SMATrix:SCAN?
```

LAN Detection

Activate "LAN Detection" to include the LAN interface in the autodetection sequence (see [Scan Instruments](#)).

Note: "LAN detection" will only work for external devices sharing the same IP subnet with the R&S ZND.

As a prerequisite, the R&S ZND must accept incoming connections on UDP port 2473. If necessary, add a corresponding inbound rule to your firewall settings.

Remote command:

n/a

Add Device

Opens the "Add External Switchmatrix" dialog that allows manual registration of an external switch matrix.

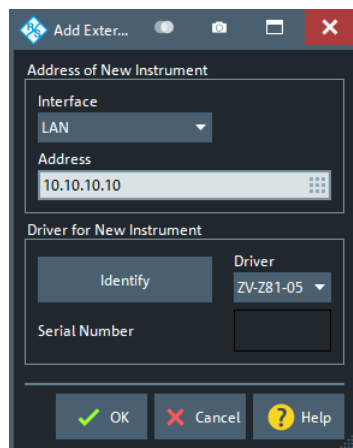

In the "Address of New Instrument" part, you can specify the required connection properties:

- "Interface" selects the connection type; currently only "LAN" is available.
- "Address" specifies the IP address or hostname of the external switch matrix.

If a connection can be established, the entries in the [Driver for New Instrument] panel can be auto-detected: "Identify" sends an identification query ("IDN?") to the specified device address in order to get the type and serial number of the connected switch matrix and to select the appropriate driver file.

Otherwise, manually select the "Driver". Matrix driver files (*.matrix) are stored in the `Resources\ExtDev` subdirectory of the analyzer's program directory.

Remote command:

```
SYSTEM:COMMunicate:RDEvice:SMATrix<Matr>:DEFine
SYSTEM:COMMunicate:RDEvice:SMATrix<Matr>:SERial?
```

Delete All

Unregisters all switch matrices, automatically deleting all switch matrix RF connections.

Remote command:

```
SYSTEM:COMMunicate:RDEvice:SMATrix:DELeTe
```

6.17.5.3 Device LAN Configuration Dialog

The "Device LAN Configuration" dialog allows to read and modify the "IP Configuration" of an external device that is equipped with a LAN interface.

Access: [External Matrices Dialog](#) > "Configure"



Because the IP configuration is actually written to the device, the device must be **online** for the settings to be applied.

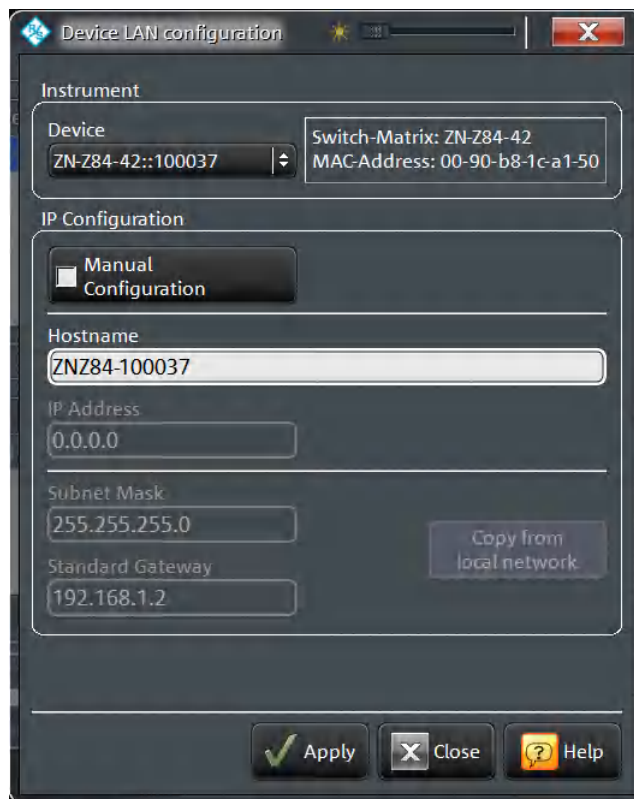

Uncheck "Manual Configuration" if the device shall discover its host configuration via DHCP. In this case only the device's "Hostname" can be specified.

In "Manual Configuration" mode also the unit's "IP Address", "Subnet Mask" and "Standard Gateway" can be set. If the unit is located in the same subnet as the analyzer, simply use "Copy from local network" to copy the "Subnet Mask" and "Standard Gateway" from the analyzer's IP settings.

6.17.5.4 Switch Matrix RF Connections Dialog

The "Switch Matrix RF Connections" dialog allows you to define the RF connections between the VNA and the switch matrices and the RF connections to the (DUT) test ports.

Access: SYSTEM – [SETUP] > "External Ports" > "RF Connections..."

The following configuration rules apply:

- Every VNA port must either be connected to a matrix port or directly assigned to a DUT test port
- Every matrix that was added to the connection configuration must be connected to the VNA by at least one RF connection
- Every VNA port that is not connected to a matrix must be assigned to a test port
- The test ports must be numbered consecutively, starting with 1

Configuration errors are displayed in balloon popups appearing at the lower left corner of the dialog.



Background information

Refer to section [Chapter 5.7.20, "External Switch Matrices"](#), on page 210.

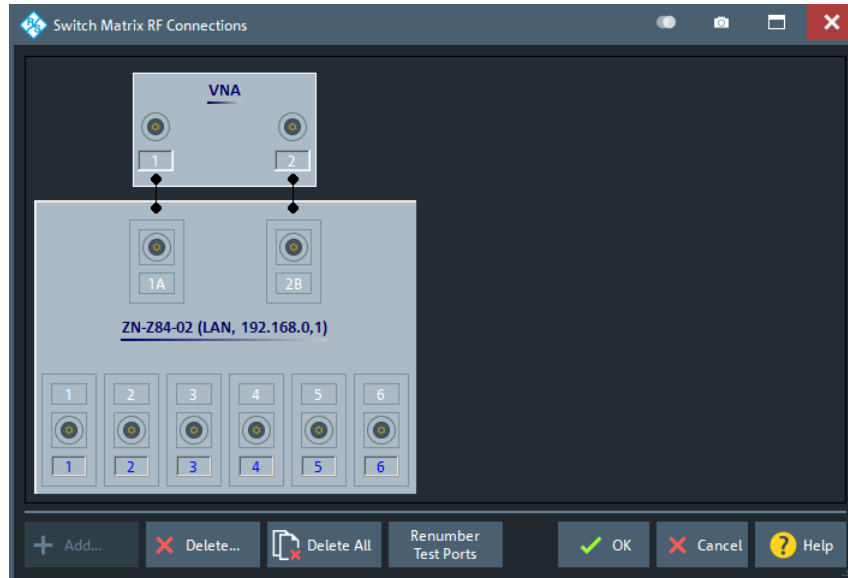

The definition of the RF connections typically involves the following steps:

1. "Add" one or more switching matrices
These matrices must have been registered before; see [Chapter 6.17.5.2, "External Matrices Dialog"](#), on page 548 for details.
2. For every matrix VNA port (the "north" ports in the graphical representation), specify the VNA port to which this matrix VNA port is physically connected or set it to "Unused" in case no such connection exists.
3. For some matrix test ports and every VNA port that is not connected to a matrix, assign a test port

Add

Opens the "Add Switch Matrix" dialog:

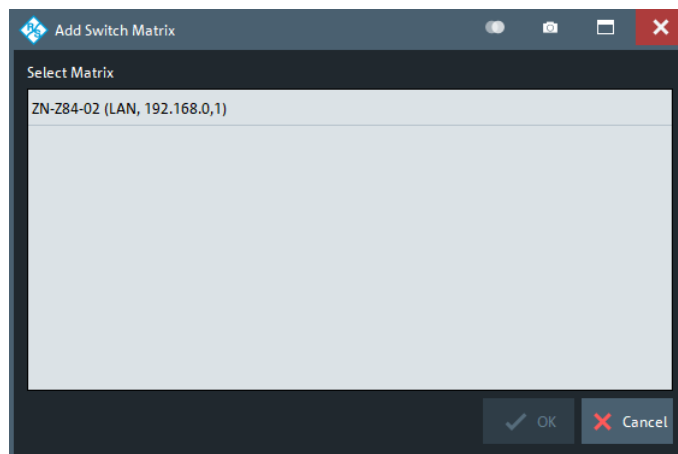

Select the required matrices and tap "OK" to add them to the RF connection configuration or tap "Cancel" to quit the dialog without adding a switch matrix to the RF connection configuration

Note:

- This dialog is shown automatically, in case no matrix has been added to the RF connection configuration yet.
- If the RF configuration already contains all registered switch matrices, the "Add" button is disabled.

Remote command:

n.a.

Delete

Opens the "Delete Switch Matrix" dialog:

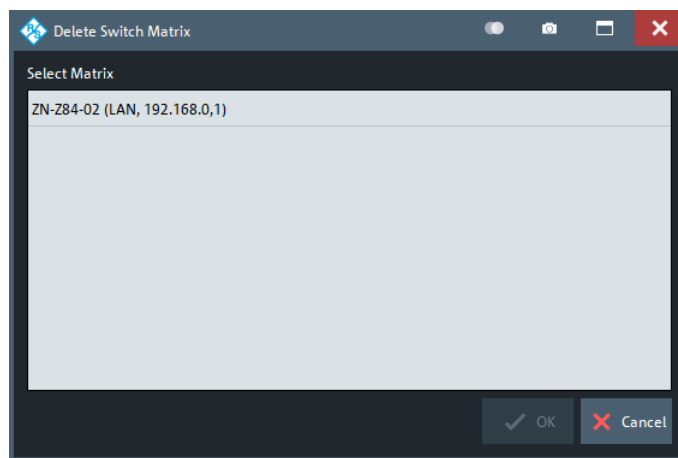

Select some matrices and tap "OK" to remove them from the RF connection configuration or tap "Cancel" to quit the dialog without removing a switch matrix from the RF connection configuration.

Delete All

Opens a confirmation dialog

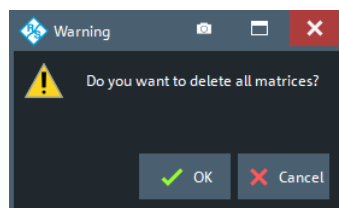

Either tap "OK" to remove all switch matrices from the RF connection configuration or tap "Cancel" to quit the dialog without removing a switch matrix.

Remote command:

[SYSTEM:COMMunicate:RDEvice:SMATrix:DELeTe](#)

Renumber Test Ports

Applies a default test port assignment to the available matrix test ports and VNA ports.

You can use this function at any time to number the used test ports in ascending order, e.g. after editing port connections. Note however that in general this will not preserve any manually created test port connections.

Remote command:

n.a.

Edit Matrix VNA Port Connections

To edit a matrix VNA port connection, tap on the corresponding port symbol.

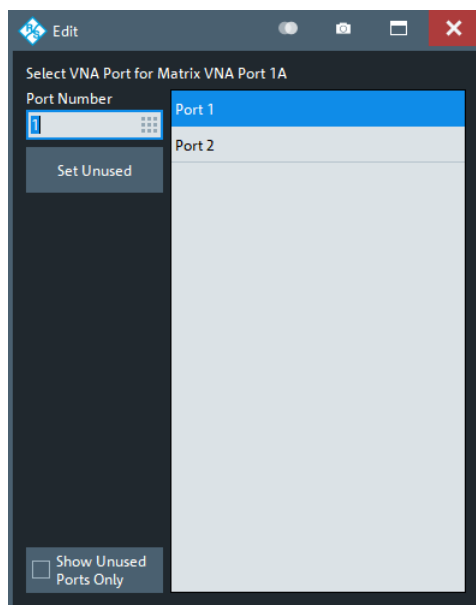

In the "Edit" dialog select the appropriate VNA port or tap "Set Unused" to delete the VNA port association.

Remote command:

```
SYSTEM:COMMunicate:RDEVICE:SMATrix<Matr>:CONFigure:MVNA  
SYSTEM:COMMunicate:RDEVICE:SMATrix<Matr>:CONFigure:MLVNA
```

Edit Test Port Connection

To edit a test port connection, tap on the corresponding port symbol.

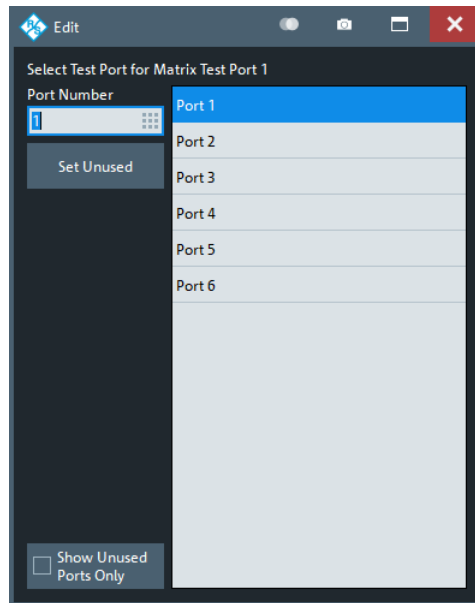

In the "Edit" dialog, select the appropriate test port or tap "Set Unused" to delete the test port association.

Remote command:

```

SYSTEM:COMMUNICATE:RDEVICE:SMATRIX<Matr>:CONFIGURE:MTEST
SYSTEM:COMMUNICATE:RDEVICE:SMATRIX<Matr>:CONFIGURE:MLTEST
SYSTEM:COMMUNICATE:RDEVICE:SMATRIX:CONFIGURE:TVNA

```

6.18 Help Softtool

The "Help" softtool presents the functions of the menu bar's "Help" menu, except calling context sensitive help.

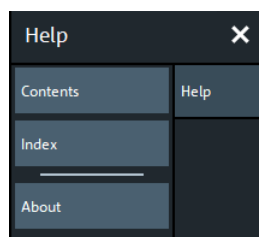

Access: "Help" – "Contents..." | "Index..." | "About..." from the menu bar.

Contents...

Opens the help browser and activates its "Contents" tab.

The "Contents" tab displays the table of contents of the analyzer's online help.

Index...

Opens the help browser and activates its "Index" tab.

The "Index" tab displays the index keywords of the analyzer's online help.

About...

Opens the "About Vna" dialog.

The "About Vna" provides basic information about the analyzer model and the current firmware. It also gives access to related license agreements.

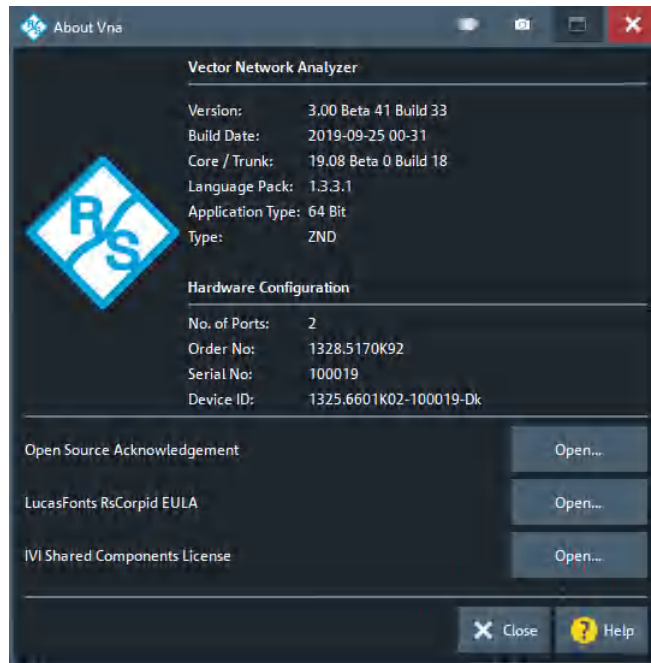

Open the [Info Dialog](#) for full information about the instrument.

6.19 Additional Function Keys

The SYSTEM hardkey panel also provides the Windows®, [HELP] and [PRESET] keys that do not open a softtool but perform an immediate action.

The DATA ENTRY panel provides hardkeys for undo and redo.

SYSTEM – [PRESET]

Performs a preset of all instrument settings or of the active recall set, depending on the settings in the [Presets Tab](#) of the "System Config" dialog.

A preset can be a factory preset or a user-defined preset. It does not affect global settings and resources (e.g. "System Config" settings, calibration kits and calibration pool etc.).

Tip: If you perform a [PRESET] by mistake, use [UNDO] to restore your previous instrument settings.

Remote command:

*RST

[SYSTem:PRESet:SCOPE](#)

[SYSTem:PRESet:USER:NAME](#)

SYSTem:PRESet:USER[:STATe]

SYSTem:PRESet[:DUMMy]

DATA ENTRY – [UNDO] / [REDO]

[UNDO] reverses the last action, [REDO] reverses a preceding [UNDO].

In the [Toolbar](#), the corresponding icons are disabled (grayed out) if an undo or redo is not possible. In general, the undo and redo actions are disabled if the size of the active recall set file exceeds 1 MB.

Tip: You can also use [UNDO] after a [SYSTEM – \[PRESET\]](#), to restore your previous instrument settings.

7 Remote Control

This chapter provides instructions on how to set up the analyzer for remote control, a general introduction to remote control of programmable instruments, and the description of the analyzer's remote control concept. For reference information about all remote control commands implemented by the instrument, complemented by comprehensive program examples, refer to [Chapter 8, "Command Reference"](#), on page 594.

7.1 Introduction to Remote Control

The instrument offers different interfaces for remote control:

- **LAN**
Analyzers connected to a LAN can be remote-controlled via the RSIB, VXI-11, or HiSLIP protocols. The LAN connector is on the rear panel of the instrument (see [Chapter 4.2, "Instrument Tour"](#), on page 28). A VISA installation on the remote control PC is required.
- **GPIB**
With option R&S ZND-B10, the analyzer offers a GPIB bus interface according to standard IEC 625.1/IEEE 488.1. If equipped, the GPIB bus connector is on the rear panel of the instrument. The R&S ZND can be remote-controlled via GPIB.
- The network analyzer can itself act as a master and control external devices via LAN, USB, or GPIB. A VISA installation on the analyzer is a prerequisite for this type of remote control. The RS VISA library is installed with the VNA firmware.
 - To control external devices via USB, the "IVI Visa Shared Components" must be installed in addition. You can easily install it from the "Start" menu of your analyzer.
 - To control external devices from the R&S ZND via GPIB, the R&S ZND-B10 can be used. An additional [USB-to-IEC/IEEE Adapter](#) is only required in case you want to control the R&S ZND via GPIB at the same time.



VISA library

VISA is a standardized software interface library providing input and output functions to communicate with instruments. The I/O channel (LAN, USB, GPIB, ...) is selected at initialization time by its channel-specific resource string (also termed address string), or by an appropriately defined VISA alias (short name).

For more information about VISA, refer to the installed library's user documentation.



HiSLIP protocol

The HiSLIP (High Speed LAN Instrument Protocol) is a protocol for TCP-based instruments specified by the IVI foundation. Compared to its predecessor VXI-11, it provides speed and other improvements. HiSLIP is encapsulated in VISA; the resource string reads `TCPIP::::hislip0`.

The RS Visa library supports HiSLIP. If the connection fails, access the Windows control panel of the controlled instrument and open port 4880 for incoming connections.

7.1.1 Starting a Remote Control Session

A remote control program must open a connection to the analyzer (using VISA functionality), before it can send commands to the analyzer and receive device responses (e.g. measurement data). The programming details depend on the library version used and on the programming language. For this reason, the examples in chapters "Command Reference" and "Programming Examples" are reduced to the mere SCPI syntax.

Example controller programs can be obtained from the Rohde & Schwarz support centers. However, it can be preferable to integrate the controller program into post-processing tools (e.g. Microsoft Excel) to list, draw, or manipulate the measured values retrieved from the analyzer.

The following tools can make remote control more comfortable and faster:

- Various software tools provide an easy-to-use graphical user interface for remote control. An example is the "GPIB Explorer" (also termed "IECWIN32") which is pre-installed on the analyzer. See [Chapter 7.1.2, "GPIB Explorer"](#), on page 560.
- Instrument drivers provide an improved interface between the test software and the test instruments. They perform the actual control of the instrument using higher-level functions for operations such as configuring, reading from, writing to, and triggering the instrument. Hence, drivers can reduce development time, eliminating the need to learn the specific command set for each instrument. In general, program development is further simplified by a graphical program environment. Rohde & Schwarz offers various R&S ZND driver types (LabView, LabWindows/CVI, IVI, VXIplug&play...) for different programming languages. The drivers are available free of charge on the product pages in the R&S internet, along with installation information.

7.1.2 GPIB Explorer

The GPIB Explorer is a software tool that allows you to connect to the analyzer, and to obtain an overview of all implemented remote control commands. You can use it to compile and run test scripts. The program can be opened from the Windows® start menu: "Programs – R&S Vector Network Analyzer – GPIB Explorer" or via SYSTEM – [APPLIC] "External Tools " > "GPIB Explorer". You can also start the executable file `iecw32.exe` in the program directory of the network analyzer (e.g.

`C:\Program Files\Rohde-Schwarz\Vector Network Analyzer\ZNB\Bin`).

After the GPIB Explorer is started, the interface and protocol for the connection to the instrument can be selected in a dialog:

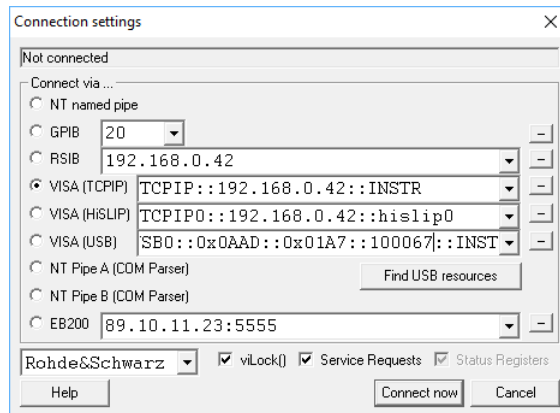

The following options are provided:

- **NT named pipe** (currently not supported)
- **GPIB address** (for connection to controllers equipped with a National Instruments GPIB interface using the GPIB bus connector)
- **RSIB, VISA (TCPIP)** and **VISA (HSLIP)** (for LAN connection, requires an appropriate IP or local host address); see [Chapter 11.1.3.1, "Assigning an IP Address"](#), on page 1151.
- **VISA (USB)**
Remote control via USB is not possible for R&S ZND.
- **NT pipe A/B (COM Parser)** (only for a GPIB Explorer installed on the analyzer, recommended for "remote" test on the instrument)
- **EB200** (currently not supported)



Select "SETUP > Setup > Info..." to look up the IP address information of your analyzer. If you run the GPIB explorer on the analyzer, the local host address (loopback address) is 127.0.0.1.

After the connection is established, the GPIB explorer displays a tree view of all commands included in the current firmware version of the network analyzer. The programs can be selected for execution by a single mouse click.

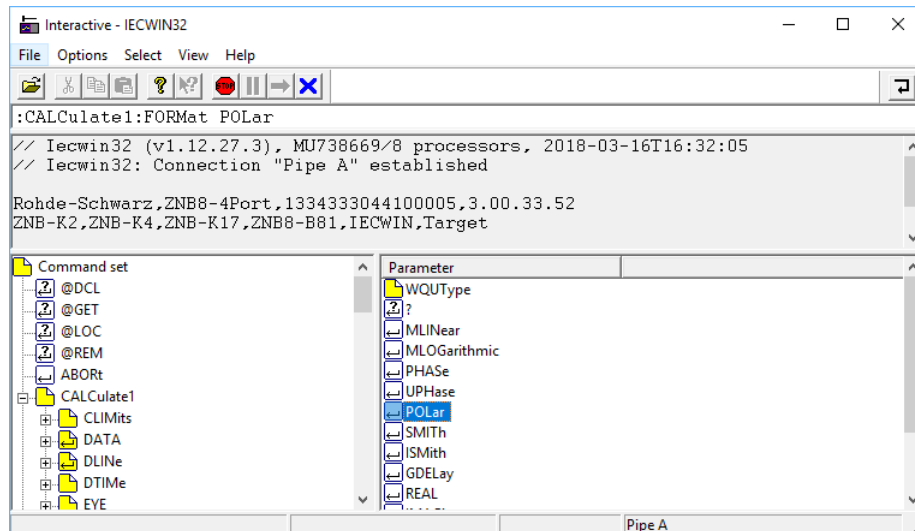

If remote logging is enabled (SYSTEM:LOGGING:REMOte[:STATE] ON) the analyzer stores all received commands to the file

'C:\Users\Public\Documents\Rohde-Schwarz\Vna\RemoteLog'.

7.1.3 Switchover to Remote Control

On power-up, the instrument is always in the manual operating state and can be operated via the front panel controls. The instrument is switched to remote control when it receives a command from the controller. If the instrument is controlled via RSIB or VXI-11 protocol, the alternative commands @REM and @LOC can be used to switch from manual to remote control and back.

While remote control is active, operation via the front panel is disabled except the "Remote" softtool. The instrument settings are optimized for maximum measurement speed; the display is switched off:

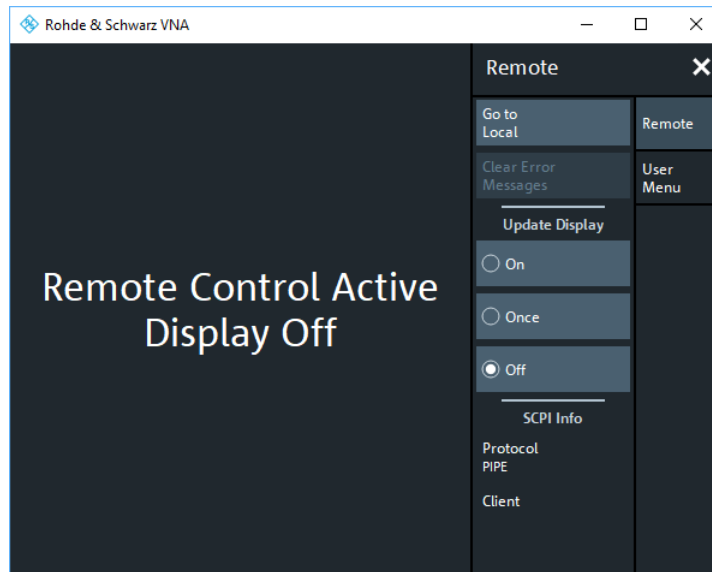

The softkeys in the remote screen are used to modify or quit the remote state:

- "Go to Local" switches the instrument to local state.
- "Display" switches the display on or off.
- If a remote error message is displayed at the bottom of the remote screen, you can use "Clear Error Messages" to delete it.

The remaining controls are for future extensions.

Display on and off states

Switching on the display means that the analyzer shows the measurement screen with the current recall sets, diagram areas and traces without leaving the remote state. In this operating mode, it is possible to observe the screen while a remote control script is executed and the control elements on the front panel are still disabled.

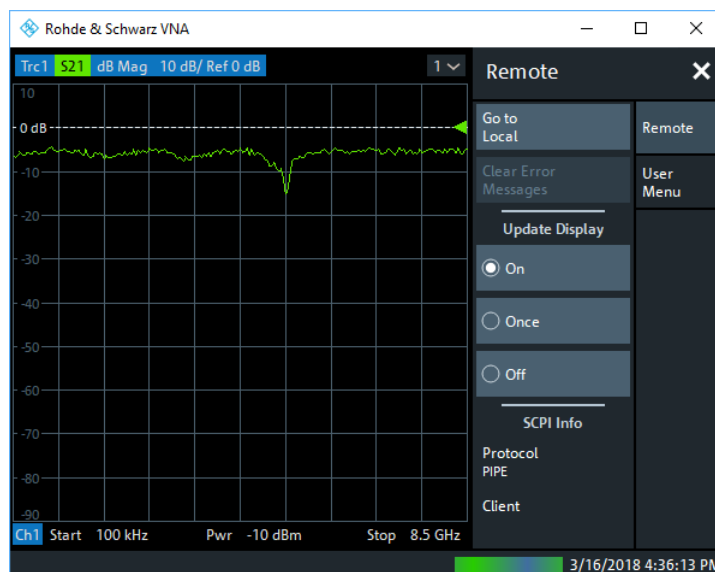

Switching on the display is ideal for program test purposes but tends to slow down the measurement. Therefore, it is recommended to switch off the display in real measurement applications where a tested program script is to be executed repeatedly.



The analyzer provides a third display option where the measurement screen is only updated when triggered by the remote control command `SYSTem:DISPlay:UPDate ONCE`.

The instrument remains in the remote state until it is reset to the manual state via the GUI or via remote control (see [Chapter 7.1.3.2, "Returning to Manual Operation"](#), on page 564). You can also lock the remote (touch) screen using `SYSTem:TSLock SCReen`.

A tooltip across the bottom of the remote screen indicates a remote command error. You can switch off this tooltip using `SYSTem:ERRor:DISPlay:REMote OFF`.

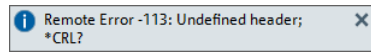

SCPI commands:

```
@REM
```

```
SYSTem:DISPlay:UPDate
```

```
SYSTem:TSLock
```

```
SYSTem:ERRor:DISPlay[:REMote]
```

7.1.3.1 Setting the Device Address

The GPIB address (primary address) of the instrument is factory-set to 20. It can be changed manually in the SYSTEM – [SETUP] > "Remote Settings" tab or via remote control. For remote control, addresses 0 through 30 are permissible. The GPIB address is maintained after a reset of the instrument settings.

SCPI commands:

```
SYSTem:COMMunicate:GPIB[:SELF]:ADDRESS
```

7.1.3.2 Returning to Manual Operation

Return to manual operation can be initiated via the front panel or via remote control.

- Manually: tap the Local softkey in the remote screen.
- Via GPIB bus: CALL IBLOC(device%)
- Via RSIB or VXI-11 protocol: @LOC and @REM can be used to switch from remote to manual control and back.



Local lockout

Before returning to manual control, command processing must be completed. If not, the analyzer switches back to remote control immediately.

Returning to manual control by tapping the "Go to Local" softkey can be disabled, e.g., by the Local Lockout Message (via GPIB: LLO; see [Chapter 11.3.3.2, "Interface Messages"](#), on page 1160). The lockout prevents unintentional switch-over, i.e. return to manual control is possible via remote control only.

Returning to manual control via the front panel keys can be enabled again, e.g. by deactivating the REN control line of the GPIB bus.

7.1.4 Combining Manual and Remote Control

Using a remote control script is the quickest and easiest way of performing complicated tasks which need to be repeated many times. However, it is often preferable to control a previously configured measurement manually to observe the result on the screen.

The analyzer provides various tools for combining manual and remote control:

- **User Keys**

The remote control commands `SYSTEM:USER:KEY...` place up to 8 softkeys with arbitrary functionality on the remote screen. The softkeys appear in the "User Menu" tab of the "Remote" softtool. When a softkey is selected, the ESR bit no. 6 (User Request) is set, and the response for `SYSTEM:USER:KEY?` is changed. This behavior can serve as a control mechanism in remote control scripts.

SCPI commands:

`SYSTEM:USER:KEY`

7.2 Messages

The messages transferred on the data lines of the GPIB bus or via the RSIB / VXI-11 protocol can be either interface messages or device messages. For a description of interface messages refer to the relevant sections:

- [Chapter 11.3.3, "GPIB Interface"](#), on page 1158
- [Chapter 11.3.2, "LAN Interface"](#), on page 1157

7.2.1 Device Messages (Commands and Device Responses)

Depending on the selected "Codec" (see `SYSTEM:COMMunicate:CODeC` on page 1020), device messages are either transferred in ANSI, UTF-8 or Shift JIS format. A distinction is made according to the direction in which device messages are transferred:

- Commands are messages the controller sends to the instrument. They operate the device functions and request information.

- Device responses are messages the instrument sends to the controller after a query. They can contain measurement results, instrument settings and information on the instrument status.

Commands are subdivided according to two criteria:

1. According to the effect they have on the instrument:
 - Setting commands cause instrument settings such as a reset of the instrument or setting the output level to some value.
 - Queries cause data to be provided for output on the GPIB bus, e.g. for identification of the device or polling the active input.
2. According to their definition in standard IEEE 488.2:
 - Common commands have a function and syntax that is precisely defined in standard IEEE 488.2. Typical tasks are the management of the standardized status registers, reset and selftest.
 - Instrument-control commands are functions that depend on the features of the instrument such as frequency settings. Most of these commands has also been standardized by the SCPI consortium.

The device messages have a characteristic structure and syntax. In the SCPI reference chapter, all commands are listed and explained in detail.

7.2.2 SCPI Command Structure and Syntax

SCPI commands consist of a so-called header and, usually, one or more parameters. The header and the parameters are separated by a white space (ASCII code 0 to 9, 11 to 32 decimal, e.g. blank). The headers may consist of several mnemonics. Queries are formed by directly appending a question mark to the header.

Common commands and device-specific commands differ in their syntax.

SCPI compatibility

The analyzers are compatible to the final SCPI version 1999.0. Not all the commands supported by the instrument are taken from the SCPI standard (Standard Commands for Programmable Instruments), however, their syntax follows SCPI rules. The SCPI standard is based on standard IEEE 488.2 and aims at the standardization of instrument-control commands, error handling and the status registers.

The requirements that the SCPI standard places on command syntax, error handling and configuration of the status registers are explained in detail in the following sections.



Reset values

In contrast to instruments with manual control, which are designed for maximum operating convenience, the priority of remote control is the predictability of the device status. This means that when incompatible settings are attempted, the command is ignored and the device status remains unchanged, i.e. other settings are not automatically adapted. Therefore, GPIB bus control programs should always define an initial device status (e.g. with the command *RST) and then implement the required settings.

7.2.2.1 Common Commands

Common (=device-independent) commands consist of a header preceded by an asterisk "*" and possibly one or more parameters.

Examples:	
*RST	RESET, resets the instrument.
*ESE 253	EVENT STATUS ENABLE, sets the bits of the event status enable registers.
*ESR?	EVENT STATUS QUERY, queries the contents of the event status register.

7.2.2.2 Instrument-Control Commands

Instrument-control commands are based on a hierarchical structure and can be represented in a command tree. The command headers are built with one or several mnemonics (keywords). The first level (root level) mnemonic identifies a complete command system.

<p>Example:</p> <p>SENSe This mnemonic identifies the command system SENSe.</p> <p>For commands of lower levels, the complete path has to be specified, starting on the left with the highest level, the individual mnemonics being separated by a colon ":".</p>
<p>Example:</p> <p>SENSe:FREQuency:START 1GHZ</p> <p>This command is located on the third level of the SENSe system. It defines the start frequency of the sweep.</p>

The following rules simplify and abbreviate the command syntax:

- **Multiple mnemonics**
Some mnemonics occur on several levels within one command system. Their effect depends on the structure of the command, i. e. on the position in the command header they are inserted in.

Example:

SOURce:FREQuency:CW 1GHZ

This command contains the mnemonic SOURce in the first command level. It defines the frequency for sweep types operating at fixed frequency.

TRIGger:SOURce EXTernal

This command contains the mnemonic `SOURce` in the second command level. It defines the trigger source “external trigger”.

- **Optional mnemonics**

Some command systems permit certain mnemonics to be optionally inserted into the header or omitted. These mnemonics are marked by square brackets in this manual. The full command length must be recognized by the instrument for reasons of compatibility with the SCPI standard. Some commands are considerably shortened by omitting optional mnemonics.

Example:

```
TRIGger[:SEquence]:SOURce EXTernal
```

This command defines the trigger source “external trigger”. The following command has the same effect:

```
TRIGger:SOURce EXTernal
```

Note:

The short form is marked by uppercase letters, the long form corresponds to the complete word. Uppercase and lowercase notation only serves to distinguish the two forms in the manual, the instrument itself is case-insensitive.

- **Parameters**

Parameters must be separated from the header by a white space. If several parameters are specified in a command, they are separated by a comma “,”. For a description of the parameter types, refer to section Parameters.

Example:

```
SOURce:GROup 1,1
```

This command defines a group of measured ports.

- **Numeric suffix**

If a device features several functions or features of the same kind, e.g. several channels or test ports, the desired function can be selected by a suffix added to the command. Entries without suffix are interpreted like entries with the suffix 1.

Example:

```
SOURce:GROup2 1,1
```

This command defines a second group (group no 2) of measured ports.

7.2.2.3 Structure of a Command Line

A command line may consist of one or several commands. It is terminated by a <New Line>, a <New Line> with EOI or an EOI together with the last data byte. Tools like the GPIB Explorer automatically produce an EOI together with the last data byte.

Several commands in a command line must be separated by a semicolon “;”. If the next command belongs to a different command system, the semicolon is followed by a colon.

Example: `TRIGger:SOURce EXTernal;;SENSe:FREQuency:STArT 1GHZ`

This command line contains two commands. The first command belongs to the `TRIGger` system and defines the trigger source (external trigger). The second command belongs to the `SENSe` system and defines the start frequency of the sweep.

If the successive commands belong to the same system, having one or several levels in common, the command line can be abbreviated. To this end, the second command

after the semicolon starts with the level that lies below the common levels. The colon following the semicolon must be omitted in this case.

Example: TRIG:SOUR EXT; :TRIG:TIM 0.1

This command line is represented in its full length and contains two commands separated from each other by the semicolon. Both commands are part of the TRIGger command system, i.e. they have one level in common.

When abbreviating the command line, the second command begins with the level below TRIG. The colon after the semicolon is omitted. The abbreviated form of the command line reads as follows:

TRIG:SOUR EXT; TIM 0.1

However, a new command line always begins with the complete path.

Example:	TRIG:SOUR EXT TRIG:THR LOW
-----------------	-------------------------------

7.2.2.4 Responses to Queries

A query is defined for each setting command unless explicitly specified otherwise. It is formed by adding a question mark to the associated setting command. According to SCPI, the responses to queries are partly subject to stricter rules than in standard IEEE 488.2.

1. The requested parameter is transmitted without header.
Example: TRIGger:SOURce? **Response:** IMM
2. Maximum values, minimum values and all further quantities which are requested via a special text parameter are returned as numerical values.
Example: SENSE:FREQuency:STOP? MAX **Response:** 8000000000
3. Numerical values are output without their unit. The default unit for each command is reported in the SCPI command description.
Example: SENSE:FREQuency:STOP? MAX **Response:** 8000000000 for 8 GHz
4. Boolean values are returned as 0 (for OFF) and 1 (for ON).
Example: SWEep:TIME:AUTO? **Response:** 1
5. Text (character data) is returned in short form (see also next section).
Example: TRIGger:SOURce? **Response:** IMM

7.2.3 SCPI Parameters

Many commands are supplemented by a parameter or a list of parameters. The parameters must be separated from the header by a "white space". Permissible parameters are numerical values, Boolean parameters, text, character strings and block data. The type of parameter required for the respective command and the permissible range of values are specified in the command description.

7.2.3.1 Numeric Values

Numeric values can be entered in any form, i.e. with sign, decimal point and exponent. Values exceeding the resolution of the instrument are rounded up or down. The mantissa may comprise up to 255 characters, the values must be in the value range – 9.9E37 to 9.9E37. The exponent is introduced by an E or e. Entry of the exponent alone is not allowed. In the case of physical quantities, the unit can be entered. Permissible unit prefixes are G (giga), MA (mega), MOHM and MHZ are also permissible), K (kilo), M (milli), U (micro) and N (nano). If the unit is missing, the default unit is used.

Example:

SOUR:RFG:FREQ 1.5GHz is equivalent to:

SOUR:RFG:FREQ 1.5E9

Special numeric values

The texts `MINimum`, `MAXimum`, `DEFault`, `UP` and `DOWN` are interpreted as special numeric values. A query returns the associated numerical value.

Example:

Setting command: `SENSe:FREQuency:StARt MINimum`

The query `SENSe:FREQuency:StARt?` returns 300000 (the exact value depends on the analyzer model).

The following special values can be used:

- `MIN/MAX MINimum` and `MAXimum` denote the minimum and maximum value of a range of numeric values.
- `DEF DEFault` denotes the preset value. This value is set by the `*RST` command.
- **UP/DOWN** `UP`, `DOWN` increases or reduces the numeric value by one step. The step width is reported in the detailed command description.
- `INF/NINF Negative INFIinity (NINF)` represent the numerical values –9.9E37 or +9.9E37, respectively. `INF` and `NINF` are only sent as device responses.
- `NAN Not a Number (NAN)` represents the value 9.91E37. `NAN` is only sent as device response. This value is not defined. Possible causes are division by zero, subtraction or addition of infinite and the representation of missing values.



Unless it is explicitly stated in the command description, you can use the special numeric parameters for all commands of the analyzer.

7.2.3.2 Boolean Parameters

Boolean parameters represent two states. The **ON** state (logically true) is represented by **ON** or a numerical value different from 0. The **OFF** state (logically false) is represented by **OFF** or the numerical value 0. A query responds with 0 or 1.

Example: Setting command: `SWEp:TIME:AUTO ON`

Query: `SWEp:TIME:AUTO?` returns 1

7.2.3.3 Text Parameters

Text parameters observe the syntax rules for mnemonics, i.e. they can be entered using a short or long form. Like any parameter, they have to be separated from the header by a white space. In the case of a query, the short form of the text is provided.

Example: Setting command: `TRIGger:SOURce EXTernal`

Query: `TRIGger:SOURce?` returns `EXT`

7.2.3.4 Strings

Strings must always be entered within single or double quotation marks (' or).

Example: `CONFigure:CHANnel:NAME "Channel 4"` or

`CONFigure:CHANnel:NAME 'Channel 4'`

7.2.3.5 Block Data Format

Block data is a transmission format which is suitable for the transmission of large amounts of data. A command using a block data parameter with definite length has the following structure:

Example: `HEADer:HEADer #45168xxxxxxxx`

The hash symbol # introduces the data block. The next number indicates how many of the following digits describe the length of the data block. In the example the 4 following digits indicate the length to be 5168 bytes. The data bytes follow. During the transmission of these data bytes all End or other control signs are ignored until all bytes are transmitted.

A #0 combination introduces a data block of indefinite length. The use of the indefinite format requires a `NL^END` message to terminate the data block. This format is useful when the length of the transmission is not known or if speed or other considerations prevent segmentation of the data into blocks of definite length.

7.2.3.6 Overview of Syntax Elements

:	The colon separates the mnemonics of a command. In a command line, the separating semicolon marks the uppermost command level.
;	The semicolon separates two commands of a command line. It does not alter the path.
,	The comma separates several parameters of a command.
?	The question mark forms a query.
*	The asterisk marks a common command.
','	Quotation marks introduce a string and terminate it.

#	The hash sign # introduces binary, octal, hexadecimal and block data. Binary: #B10110 Octal: #O7612 Hexadecimal: #HF3A7 Block: #21312
	A "white space" (ASCII-Code 0 to 9, 11 to 32 decimal, e.g. blank) separates header and parameter.

7.3 Basic Remote Control Concepts

The functionality of the network analyzer's remote control commands has been defined in close analogy to the menu commands and control elements of the graphical user interface (GUI). The basic concepts of recall sets, traces, channels, and diagram areas remain valid in remote control. Moreover, all commands follow SCPI syntax rules, and SCPI-confirmed commands have been used whenever possible. These principles largely simplify the development of remote control scripts.

The GUI and the remote control command set both aim at maximum operating convenience. In manual control this generally means that the control elements are easy to find and intuitive to handle, and that the effect of each operation is easy to verify on the screen. Convenient remote control operation depends on a simple and systematic program syntax and on a predictable instrument state; the display of results is secondary.

These differences suggest the peculiarities in the analyzer's remote control concept discussed in the following sections.

7.3.1 Traces, Channels, and Diagram Areas

Like in manual control, traces can be assigned to a channel and displayed in diagram areas (see section Traces, Channels and Diagram Areas in Chapter 3). There are two main differences between manual and remote control:

- A trace can be created without being displayed on the screen.
- A channel must not necessarily contain a trace. Channel and trace configurations are independent of each other.

The following frequently used commands create and delete traces, channels, and diagram areas:

Create new trace and new channel (if channel <Ch> does not exist yet)	CALCulate<Ch>:PARAmeter:SDEFine '<Trace Name>', '< Meas Parameter>
Delete trace	CALCulate<Ch>:PARAmeter:DELEte '<Trace Name>'
Create or delete channel	CONFigure:CHANnel<Ch>[:STATe] ON OFF
Create or delete diagram area	DISPlay:WINDow<Wnd>:STATe ON OFF
Display trace in diagram area	DISPlay:WINDow<Wnd>:TRACe<WndTr>:FEED

The assignment between traces, channels, and diagram areas is defined via numeric suffixes as illustrated in the following example:

Example:

```
CALC4:PAR:SDEF 'Ch4Tr1', 'S11'
```

Create channel 4 (channel suffix 4) and a trace named "Ch4Tr1" to measure the input reflection coefficient S11. The trace is created but not displayed.

```
DISP:WIND2:STAT ON
```

Create diagram area no. 2 (window suffix 2).

```
DISP:WIND2:TRAC9:FEED 'CH4TR1'
```

Display the generated trace (identified by its name "Ch4Tr1") in diagram area no. 2 (window suffix 2), assigning the trace number 9 (trace suffix 9) to it.

7.3.2 Active Traces in Remote Control

In manual control there is always exactly one active trace, irrespective of the number of channels and traces defined. The "active channel" contains the active trace; see [Chapter 5.1.3.1, "Trace Settings"](#), on page 71.

In remote control, each channel contains an active trace (unless the channel contains no trace at all). This principle actually simplifies the remote control command syntax, because it allows the active trace in a particular channel to be referenced by means of the channel suffix. No additional trace identifier is needed; there is no need either to distinguish channel and trace settings using mnemonics or suffixes.

The active traces are handled as follows:

- After a preset (*RST), the analyzer displays a single diagram area with the default trace no. 1 named Trc1. The trace is active in manual and in remote control.
- In manual control, a new, added trace automatically becomes the active trace. To select another trace as the active trace, tap inside the trace list.
- In remote control, a new trace added via CALCulate<Ch>:PARAmeter:SDEFine '<trace_name>', '<parameter>' also becomes the active trace. To select another trace as the active trace, use (CALCulate<Ch>:PARAmeter:SElect '<trace_name>').
- The active traces for manual and remote control may be different.

The following program example illustrates how to create, select and reference traces. It is instructive to observe the analyzer screen in order to check the effect of each step.

Example:

```
*RST
```

Reset the analyzer, creating channel no. 1 with the default trace "Trc1". The trace is displayed in diagram area no. 1.

```
CALC1:PAR:SDEF 'Trc2', 'S11'; DISP:WIND:TRAC2:FEED 'Trc2'
```

Create a new trace named "Trc2", assigned to channel no. 1 (the suffix 1 after CALC, may be omitted), and display the trace. The new trace automatically becomes the active trace for manual and for remote control. To check this, tap "Trace – Marker – Marker 1" to create a marker. The marker is assigned to "Trc2". Delete all markers ("Trace – Marker – All Markers Off").

```
CALC1:MARK ON
```

Example:

To verify that "Trc2" is also active for remote control, use the channel suffix 1 after CALC (may be omitted) to reference the active trace in channel 1 and create a marker "Mkr 1". The marker is assigned to "Trc2".

Example:

```
CALC:PAR:SEL 'Trc1'; CALC1:MARK ON
```

Select the old default trace "Trc1" as the active trace for remote control. Create a new marker to verify that "Trc1" is now the active trace in channel 1.



In the SCPI command description, the numeric suffix <Ch> is used for channel settings (it denotes the configured channel), whereas <Chn> is used for trace settings (it refers to the active trace in the channel).

7.3.3 Initiating Measurements, Speed Considerations

After a reset the network analyzer measures in continuous mode. The displayed trace shows the result of the last sweep and is continuously updated. This provides a permanent visual control over the measurement and the effect of any analyzer settings.

In remote control, it is advisable to follow a different approach in order use the analyzer's resources to full capacity and gain measurement speed. The following principles can help to optimize a remote control program (see also programming example in [Chapter 9.1.1, "Typical Stages of a Remote Control Program"](#), on page 1110):

- Switch off the measurement while configuring your instrument.
- Use a minimum number of suitably positioned sweep points.
- Start a single sweep, observing proper command synchronization, and retrieve your results.

The following command sequence performs a single sweep in a single channel.

Example:

```
*RST; :INITiate:CONTinuous:ALL OFF
```

Activate single sweep mode for all channels (including the channels created later).

```
INITiate1:IMMediate; *WAI
```

Start a single sweep in channel no. 1, wait until the sweep is terminated before proceeding to the next command (see [Chapter 7.4, "Command Processing"](#), on page 576).

**Sweeps in several channels**

It is also possible to subdivide the channels within a recall set into active and inactive channels. The analyzer will then measure in the subset of active channels only; see program example for `CONFigure:CHANnel<Ch>:MEASure[:STATe]`.

7.3.4 Addressing Traces and Channels

The analyzer provides a variety of schemes for addressing traces and channels and for querying trace and channel names. The following tables give an overview.

Table 7-1: Addressing channels

Method	Commands / Example
Channel number <Ch> as a numeric suffix	CONFigure:CHANnel<Ch>[:STATe] ON
Query all channel names	CONFigure:CHANnel:CATalog? (returns the names of all channels)
Assign or query channel name of a channel numbered <Ch>	CONFigure:CHANnel<Ch>:NAME 'ABCD' CONFigure:CHANnel<Ch>:NAME? (returns 'ABCD')
Query channel number assigned to a channel named 'ABCD'	CONFigure:CHANnel<Ch>:NAME:ID? 'ABCD' (returns the actual channel number, the channel suffix is ignored)

Table 7-2: Addressing traces

Method	Commands / Example
Channel number <Chn> used as a reference for the active trace in the channel	CALCulate<Chn>:MARKer<Mk>[:STATe] ON
Trace name (string variable) used as a reference for the trace	CALCulate<Ch>:PARAMeter:DElete '<Trace Name>'
Trace number <Trc> as a numeric suffix (exception!)	CONFigure:TRACe<Trc>:NAME?
Trace number <WndTr> within a particular diagram area <Wnd>	DISPlay:WINDow<Wnd>:TRACe<WndTr>:FEED
Query all trace names	CONFigure:TRACe:CATalog? (returns the names of all traces)

Method	Commands / Example
Assign or query trace name of a trace numbered <Trc>	CONFigure:TRACe<Trc>:NAME 'ABCD' CONFigure:TRACe<Trc>:NAME? (returns 'ABCD')
Query trace number assigned to a trace named 'ABCD'	CONFigure:TRACe<Trc>:NAME:ID? 'ABCD' (returns the actual trace number; the trace suffix is ignored)

Table 7-3: Mixed commands

Method	Commands / Example
Query channel name for a trace referenced by its trace name	CONFigure:TRACe<Trc>:CHANnel:NAME? 'ABCD' (returns the channel name for trace 'ABCD'; the trace suffix is ignored)
Query channel number for a trace referenced by its trace name	CONFigure:TRACe<Trc>:CHANnel:NAME:ID? 'ABCD' (returns the actual channel number for trace 'ABCD'; the trace suffix is ignored)

7.4 Command Processing

The block diagram below shows how commands are serviced in the instrument.

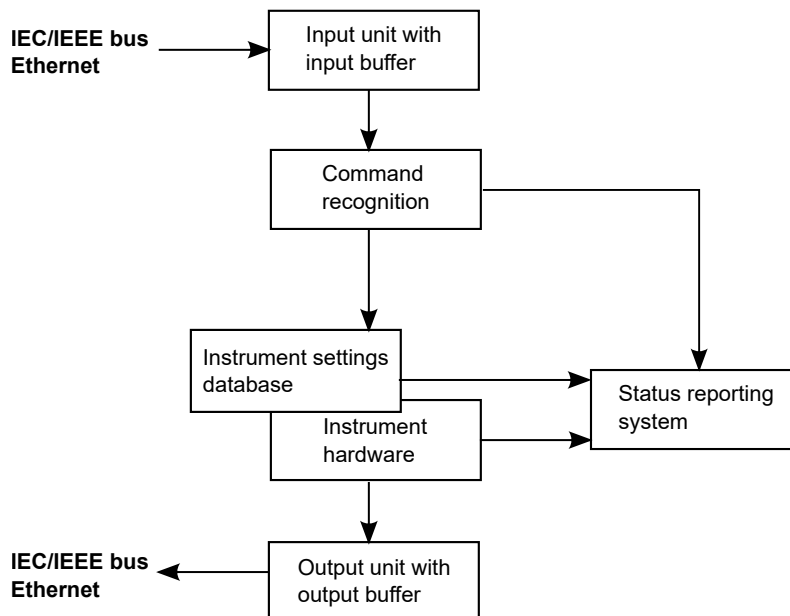

The individual components work independently and simultaneously. They communicate with each other with so-called messages.

7.4.1 Input Unit

The input unit receives commands character by character from the controller and collects them in the input buffer. The input unit sends a message to the command recog-

tion when the input buffer is full or when it receives a delimiter, <PROGRAM MESSAGE TERMINATOR>, as defined in IEEE 488.2, or the interface message DCL.

If the input buffer is full, the message data traffic is stopped and the data received up to then is processed. Subsequently the traffic is continued. If, however, the buffer is not yet full when receiving the delimiter, the input unit can already receive the next command during command recognition and execution. The receipt of a DCL clears the input buffer and immediately initiates a message to the command recognition.

7.4.2 Command Recognition

The command recognition stage analyzes the data received from the input unit. It proceeds in the order in which it receives the data. Only a DCL is serviced with priority, e.g. a GET (Group Execute Trigger) is only executed after the commands received before. Each recognized command is immediately transferred to the data set but not executed immediately.

The command recognition detects syntax errors in the commands and transfers them to the status reporting system. The rest of a command line after a syntax error is still executed, if possible. After the syntax check, the range of the numerical parameters is checked, if necessary.

If the command recognition detects a delimiter or a DCL, it also requests the data set to perform the necessary instrument hardware settings. Subsequently it is immediately prepared to process further commands. This means that new commands can already be serviced while the hardware is still being set (overlapping execution).

7.4.3 Data Base and Instrument Hardware

The expression instrument hardware denotes the part of the instrument fulfilling the actual instrument function – signal generation, measurement etc. The controller is not included. The data base manages all the parameters and associated settings required for the instrument hardware.

Setting commands lead to an alteration in the data set. The data set management enters the new values (e.g. frequency) into the data set, however, it only passes them on to the hardware when requested by the command recognition. This can only occur at the end of a command line, therefore the order of the setting commands in the command line is not relevant.

The commands are only checked for their compatibility among each other and with the instrument hardware immediately before they are transmitted to the instrument hardware. If the instrument detects that execution is not possible, an execution error is signaled to the status reporting system. All alterations of the data set are canceled, the instrument hardware is not reset. Due to the delayed checking and hardware setting, however, impermissible instrument states can be set for a short period of time within one command line without this leading to an error message (example: simultaneous activation of a frequency and a power sweep). At the end of the command line, however, a permissible instrument state must have been reached again.

Before passing on the data to the hardware, the settling bit in the `STATUS:OPERation` register is set (see [Chapter 7.5.3.4, "STATUS:OPERation"](#), on page 586). The hardware executes the settings and resets the bit again as soon as the new state has settled. This fact can be used to synchronize command servicing.

Queries induce the data set management to send the desired data to the output unit.

7.4.4 Status Reporting System

The status reporting system collects information on the instrument state and makes it available to the output unit on request. The exact structure and function are described in [Chapter 7.5, "Status Reporting System"](#), on page 580.

7.4.5 Output Unit

The output unit collects the information requested by the controller, which it receives from the data set management. It processes it according to the SCPI rules and makes it available in the output buffer. If the information requested is longer, it is made available in portions without this being recognized by the controller.

If the instrument is addressed as a talker without the output buffer containing data or awaiting data from the data set management, the output unit sends the error message `Query UNTERMINATED` to the status reporting system. No data is sent on the GPIB bus or via the Ethernet, the controller waits until it has reached its time limit. This behavior is specified by SCPI.

7.4.6 Command Sequence and Command Synchronization

IEEE 488.2 defines a distinction between overlapped and sequential commands:

- A sequential command is one which finishes executing before the next command starts executing. Commands that are processed quickly are usually implemented as sequential commands.
- An overlapping command is one which does not automatically finish executing before the next command starts executing. Usually, overlapping commands take longer to process and allow the program to do other tasks while being executed. If overlapping commands do have to be executed in a defined order, e.g. to avoid wrong measurement results, they must be serviced sequentially. This is called synchronization between the controller and the analyzer.

According to [Chapter 7.4.3, "Data Base and Instrument Hardware"](#), on page 577, setting commands within one command line, even though they may be implemented as sequential commands, are not necessarily serviced in the order in which they have been received. To make sure that commands are actually carried out in a certain order, each command must be sent in a separate command line. Examples:

Example 1: Commands and queries in one message

The response to a query combined in a program message with commands that affect the queried value is not predictable. Sending

```
:FREQ:STAR 1GHZ;SPAN 100
```

```
:FREQ:STAR?
```

always returns 1000000000 (1 GHz). When:

```
:FREQ:STAR 1GHz;STAR?;SPAN 1000000
```

is sent, however, the result is not specified by SCPI. The result could be the value of `START` before the command was sent since the instrument might defer executing the individual commands until a program message terminator is received. The result could also be 1 GHz if the instrument executes commands as they are received.

As a rule, send commands and queries in different program messages.

Example 2: Overlapping command with *OPC

The analyzer implements `INITiate[:IMMEDIATE]...` commands as overlapped commands. Assuming, e.g., that `INITiate[:IMMEDIATE][:DUMMY]` takes longer to execute than `*OPC`, sending the command sequence:

```
INIT; *OPC.
```

results in initiating a sweep and, after some time, setting the OPC bit in the ESR. Sending the commands:

```
INIT; *OPC; *CLS
```

still initiates a sweep. Since the operation is still pending when the analyzer executes `*CLS`, forcing it into the Operation Complete Command Idle State (OCIS), `*OPC` is effectively skipped. The OPC bit is not set until the analyzer executes another `*OPC` command.



The analyzer provides only two overlapped commands, `INITiate<Ch>[:IMMEDIATE][:DUMMY]` and `INITiate<Ch>[:IMMEDIATE]:ALL`. What is said below is not relevant for the other (sequential) SCPI commands.



Preventing overlapping execution

To prevent an overlapping execution of commands, one of the commands `*OPC`, `*OPC?` or `*WAI` can be used. For a programming example, refer to [Chapter 9.1.1.3, "Start of the Measurement and Command Synchronization"](#), on page 1111.

Command	Action after the hardware has settled	Programming the controller
*WAI	Stops further command processing until all commands sent before *WAI have been executed Note: The GPIB bus handshake is not stopped	Send *WAI directly after the command which should be terminated before the next command is executed.
*OPC?	Stops command processing until 1 is returned, i.e. until the "Operation Complete" bit has been set in the ESR. This bit indicates that the previous commands have been completed.	Send *OPC? directly after the command which should be terminated before the next command is executed.
*OPC	Sets the operation complete bit in the ESR after all previous commands have been executed.	<ul style="list-style-type: none"> – Set bit 0 in the ESE – Set bit 5 in the SRE – Wait for service request (SRQ)

7.5 Status Reporting System

The status reporting system stores all information on the present operating state of the instrument, and on errors which have occurred. This information is stored in the status registers and in the error queue. Both can be queried using the `STATus...` commands.

Hierarchy of status registers

As shown in section [Overview of Status Registers](#), the status information is of hierarchical structure.

- **STB, SRE:**
The `STatus Byte (STB)` register and its associated mask register `Service Request Enable (SRE)` make up the highest level of the status reporting system. The `STB` provides a rough overview of the instrument status, collecting the information of the lower-level registers.
- The `STB` receives its information from:
The `Event Status Register (ESR)` with the associated mask register `standard Event Status Enable (ESE)`.
The `STATus:OPERation` and `STATus:QUESTIONable` registers which are defined by `SCPI` and contain detailed information on the instrument.
- **IST, PPE:**
The `Individual STatus (IST)` flag, like the `SRQ`, combines the entire instrument status in a single bit. The `PPE` is associated to the `IST` flag. It fulfills an analogous function for the `IST` flag as the `SRE` does for the service request.
- **Output buffer:**
contains the messages the instrument returns to the controller. It is not part of the status reporting system but determines the value of the `MAV` bit in the `STB`.

All status registers have the same internal structure, see [Structure of a SCPI Status Register](#).

For more information on the individual status registers, see [Contents of the Status Registers](#).



SRE register

The service request enable register SRE can be used as ENABLE part of the STB if the STB is structured according to SCPI. By analogy, the ESE can be used as the ENABLE part of the ESR.

7.5.1 Overview of Status Registers

The status registers of the R&S ZND are implemented as shown below.

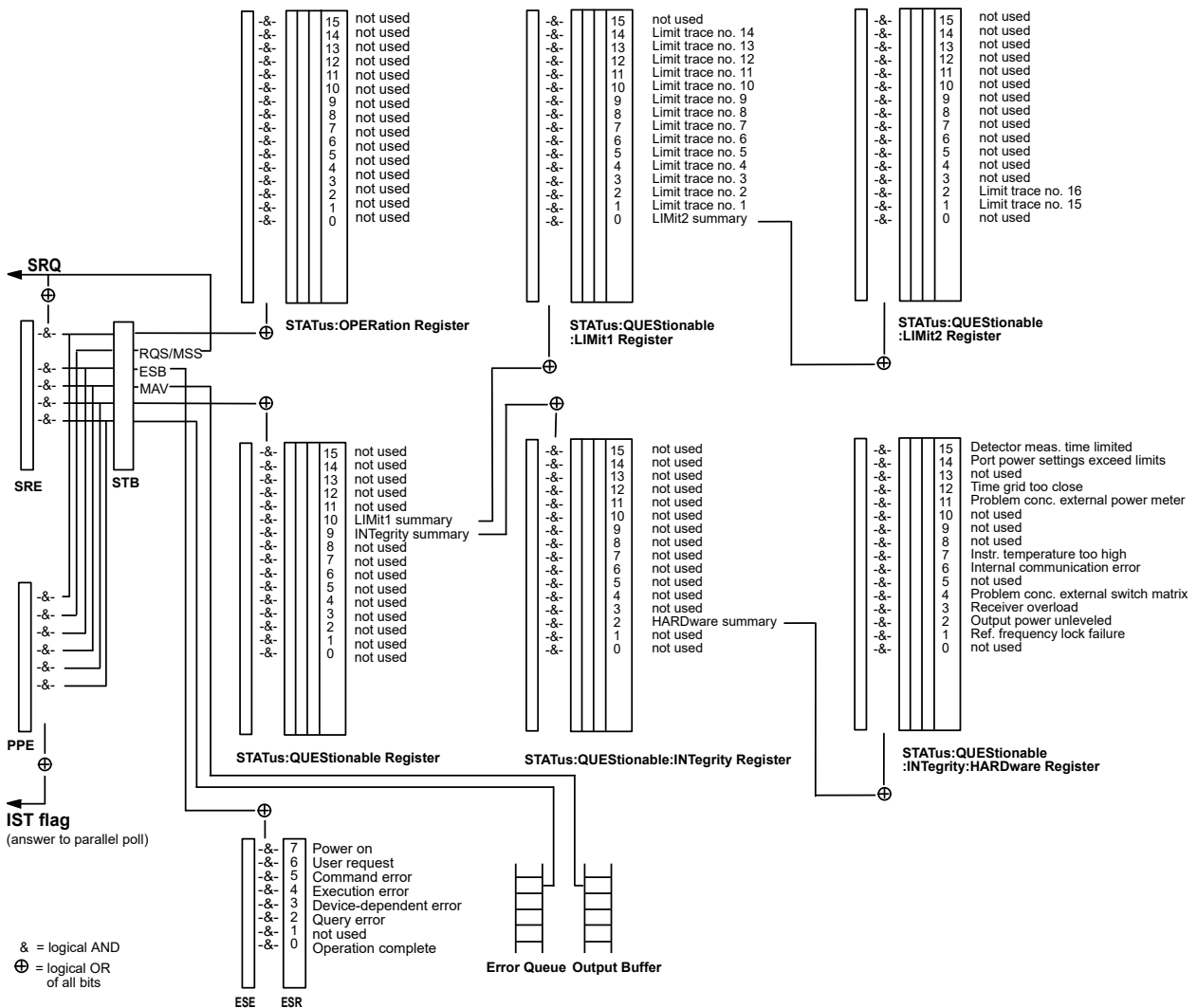

7.5.2 Structure of a SCPI Status Register

Each standard SCPI register consists of 5 parts which each have a width of 16 bits and have different functions. The individual bits are independent of each other, i.e. each hardware status is assigned a bit number which is valid for all five parts. Bit 15 (the

most significant bit) is set to zero for all parts. Thus the contents of the register parts can be processed by the controller as positive integer.

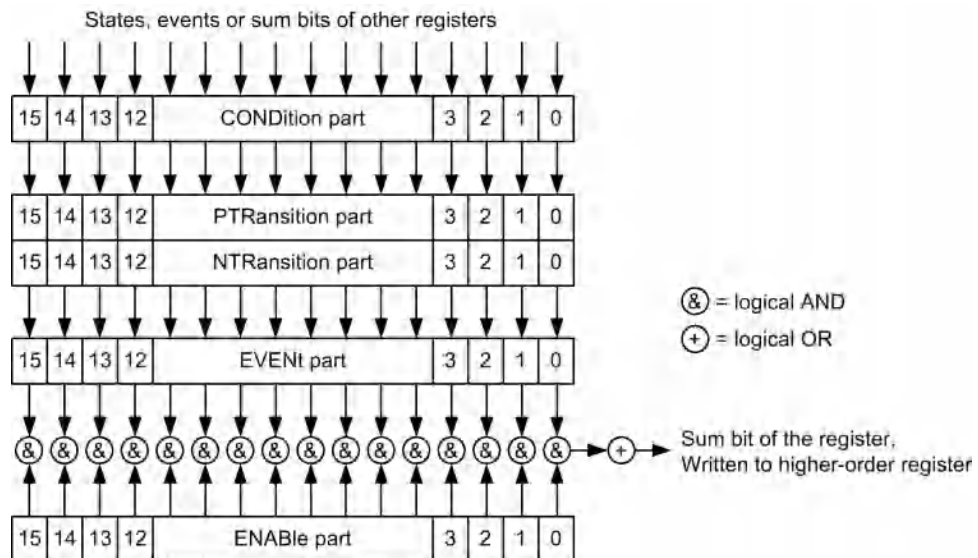

The sum bit is obtained from the EVENT and ENABLE part for each register. The result is then entered into a bit of the CONDition part of the higher-order register.

The instrument automatically generates the sum bit for each register. Thus an event can lead to a [Service Request](#) throughout all levels of the hierarchy.

The five parts of a SCPI register have different properties and function as described below.

CONDition

The CONDition part is permanently overwritten by the hardware or the sum bit of the next lower register. Its contents always reflect the current instrument state.

This register part can only be read, but not overwritten or cleared. Reading the CONDition register is nondestructive.

PTRansition

The two transition register parts define which state transition of the condition part (none, 0 to 1, 1 to 0 or both) is stored in the EVENT part.

The Positive TRansition part acts as a transition filter. When a bit of the CONDition part is changed from 0 to 1, the associated PTR bit decides whether the EVENT bit is set to 1:

- PTR bit = 1: the EVENT bit is set
- PTR bit = 0: the EVENT bit is not set

This status register part can be overwritten and read at will. Reading the PTRansition register is nondestructive.

NTRansition

The Negative TRansition part also acts as a transition filter. When a bit of the CONDi-tion part is changed from 1 to 0, the associated NTR bit decides whether the EVENt bit is set to 1.

- NTR bit = 1: the EVENt bit is set.
- NTR bit = 0: the EVENt bit is not set.

This part can be overwritten and read at will. Reading the PTRansition register is non-destructive.

EVENT

The EVENt part indicates whether an event has occurred since the last reading, it is the "memory" of the condition part. It only indicates events passed on by the transition filters. It is permanently updated by the instrument. This part can only be read by the user. Reading the register clears it. This part is often equated with the entire register.

ENABLE

The ENABle part determines whether the associated EVENt bit contributes to the sum bit (cf. below). Each bit of the EVENt part is ANDed with the associated ENABle bit (symbol '&'). The results of all logical operations of this part are passed on to the sum bit via an OR function (symbol '+').

- ENAB bit = 0: The associated EVENt bit does not contribute to the sum bit.
- ENAB bit = 1: If the associated EVENt bit is "1", the sum bit is set to "1" as well.

This part can be overwritten and read by the user at will. Its contents are not affected by reading.

The **sum bit** is obtained from the EVENt and ENABle part for each register. The result is then entered into a bit of the CONDi-tion part of the higher-order register. The instrument automatically generates the sum bit for each register. Thus an event can lead to a service request throughout all levels of the hierarchy.

7.5.3 Contents of the Status Registers

The individual status registers are used to report different classes of instrument states or errors. The following status registers belong to the general model described in IEEE 488.2:

- The SStatus Byte (STB) gives a rough overview of the instrument status.
- The Individual SStatus (IST) flag combines the entire status information into a single bit that can be queried in a [Parallel Poll](#).
- The Event Status Register (ESR) indicates general instrument states.

The status registers below belong to the device-dependent SCPI register model:

- The STATus:OPERation register contains conditions which are part of the instrument's normal operation.
- The STATus:QUEStionable register indicates whether the data currently being acquired is of questionable quality.

- The `STATUS:QUESTIONABLE:LIMIT<1|2>` register indicates the result of the limit check.
- The `STATUS:QUESTIONABLE:INTEGRITY` register monitors hardware failures of the analyzer.

7.5.3.1 STB and SRE

The Status Byte (STB) provides a rough overview of the instrument status by collecting the pieces of information of the lower registers. The STB represents the highest level within the SCPI hierarchy. A special feature is that bit 6 acts as the summary bit of the remaining bits of the status byte.

The STB is linked to the Service Request Enable (SRE) register on a bit-by-bit basis.

- The STB corresponds to the `EVENT` part of a SCPI register, indicating the current instrument state. This register is cleared when it is read.
- The SRE corresponds to the `ENABLE` part of a SCPI register. If a bit is set in the SRE and the associated bit in the STB changes from 0 to 1, a [Service Request \(SRQ\)](#) is generated. Bit 6 of the SRE is ignored, because it corresponds to the summary bit of the STB.

The bits in the STB are defined as follows:

Bit No.	Meaning
2	<p>Error queue not empty</p> <p>If this bit is enabled by the SRE, each entry of the error queue generates a Service Request (SRQ). Thus an error can be recognized and further pinned down by polling the error queue. The poll provides an informative error message.</p>
3	<p>QUESTIONABLE status summary bit</p> <p>This bit is set if an <code>EVENT</code> bit is set in the <code>STATUS:QUESTIONABLE</code> register and the associated <code>ENABLE</code> bit is set to 1.</p> <p>The bit indicates a questionable instrument status, which can be further pinned down by polling the <code>QUESTIONABLE</code> register.</p>
4	<p>MAV bit (message available)</p> <p>This bit is set if a message is available and can be read from the output buffer.</p> <p>This bit can be used to transfer data from the instrument to the controller automatically.</p>
5	<p>ESB bit</p> <p>Sum bit of the event status register. It is set if one of the bits in the event status register is set and enabled in the event status enable register.</p> <p>Setting of this bit implies an error or an event which can be further pinned down by polling the event status register.</p>
6	<p>MSS bit (master status summary bit)</p> <p>This bit is set if the instrument triggers a service request, which happens if one of the other bits of this register is set together with its mask bit in the SRE register.</p>
7	<p>OPERATION status register summary bit</p> <p>This bit is set if an <code>EVENT</code> bit is set in the <code>OPERATION</code> status register and the associated <code>ENABLE</code> bit is set to 1.</p> <p>The bit indicates that the instrument is performing an action. The type of action can be determined by polling the <code>STATUS:OPERATION</code> register.</p>

Related common commands

The STB is read out using the command `*STB?` or a [Serial Poll](#).

The SRE can be set using command `*SRE` and read using `*SRE?`.

7.5.3.2 IST Flag and PPE

In analogy to the [Service Request](#) (SRQ), the Individual Status (IST) flag combines the entire status information in a single bit. It can be queried by a [Parallel Poll](#).

The Parallel Poll Enable (PPE) register determines which bits of the STB contribute to the IST flag. The bits of the STB are ANDed with the corresponding bits of the PPE, with bit 6 being used as well in contrast to the SRE. The IST flag results from ORing all results.

Related common commands

The IST flag is queried using the common command `*IST?`. The PPE can be set using `*PRE` and read using `*PRE?`.

See also [Common Commands](#).

7.5.3.3 ESR and ESE

The Event Status Register (ESR) indicates general instrument states. It is linked to the Event Status Enable (ESE) register on a bit-by-bit basis.

- The ESR corresponds to the CONDition part of a SCPI register indicating the current instrument state (although reading is destructive).
- The ESE corresponds to the ENABLE part of a SCPI register. If a bit is set in the ESE and the associated bit in the ESR changes from 0 to 1, the ESB bit in the Status Byte (STB) is set.

The bits in the ESR are defined as follows:

Bit No.	Meaning
0	<p>Operation complete</p> <p>This bit is set on receipt of the command <code>*OPC</code> after all previous commands have been executed.</p>
2	<p>Query error</p> <p>This bit is set if either the controller wants to read data from the instrument without having sent a query, or if it does not fetch requested data and sends new instructions to the instrument instead. The cause is often a query which is faulty and hence cannot be executed.</p>
3	<p>Device-dependent error</p> <p>This bit is set if a device-dependent error occurs. An error message with a number between -300 and -399 or a positive error number, which describes the error in greater detail, is entered into the error queue. See also Chapter 10, "Error Messages and Troubleshooting", on page 1143.</p>

Bit No.	Meaning
4	Execution error This bit is set if a received command is syntactically correct, but cannot be performed for other reasons. An error message with a number between -200 and -300, which describes the error in greater detail, is entered into the error queue.
5	Command error This bit is set if a command which is undefined or syntactically incorrect is received. An error message with a number between -100 and -200, which describes the error in greater detail, is entered into the error queue.
6	User request This bit is set when the instrument is switched over to manual control or when a user-defined softkey is used (see SYSTem:USER:KEY).
7	Power On (supply voltage on) This bit is set when the instrument is switched on.

Related common commands

The Event Status Register (ESR) can be queried using `ESR?`. The Event Status Enable (ESE) register can be set using the command `*ESE` and read using `*ESE?`.

See also [Common Commands](#).

7.5.3.4 STATus:OPERation

The STATus:OPERation register contains conditions which are part of the instrument's normal operation. The analyzer does not use the STATus:OPERation register.

7.5.3.5 STATus:QUEStionable

The STATus:QUEStionable register indicates whether the acquired data is of questionable quality and monitors hardware failures of the analyzer. It can be queried using the commands `STATus:QUEStionable:CONDition?` or `STATus:QUEStionable:EVENT?`.

Bit No.	Meaning
9	INTEgrity register summary This bit is set if a bit is set in the STATus:QUEStionable:INTEgrity register and the associated ENABLE bit is set to 1.
10	LIMit register summary This bit is set if a bit is set in the STATus:QUEStionable:LIMit1 register and the associated ENABLE bit is set to 1.

STATus:QUEStionable:LIMit<1|2>

The STATus:QUEStionable:LIMit<1|2> registers indicate the result of the limit check. They can be queried using the commands `STATus:QUEStionable:LIMit<1|2>:CONDition?` or

`STATUS:QUESTIONABLE:LIMIT<1|2>[:EVENT]?`

`STATUS:QUESTIONABLE:LIMIT1` is also the summary register of the lower level

`STATUS:QUESTIONABLE:LIMIT2` register.

The bits in the `STATUS:QUESTIONABLE:LIMIT1` register are defined as follows:

Bit No.	Meaning
0	LIMIT2 register summary This bit is set if a bit is set in the <code>STATUS:QUESTIONABLE:LIMIT2</code> register and the associated <code>ENABLE</code> bit is set to 1.
1	Failed limit check for trace no. 1 This bit is set if any point on trace no. 1 fails the limit check.
...	...
14	Failed limit check for trace no. 14 This bit is set if any point on trace no. 14 fails the limit check.

The bits in the `STATUS:QUESTIONABLE:LIMIT2` register are defined as follows:

Bit No.	Meaning
0	Not used
1	Failed limit check for trace no. 15 This bit is set if any point on trace no. 15 fails the limit check.
2	Failed limit check for trace no. 16 This bit is set if any point on trace no. 16 fails the limit check.

Numbering of traces

The traces numbers 1 to 16 are assigned as follows:

- Traces assigned to channels with smaller channel numbers have smaller trace numbers.
- Within a channel, the order of traces reflects their creation time: The oldest trace has the smallest, the newest trace has the largest trace number. This is equivalent to the order of traces in the response string of the `CALCulate<Ch>:PARAMeter:CATalog? query`.
- The number of traces monitored cannot exceed 16. If a setup contains more traces, the newest traces are not monitored.

STATUS:QUESTIONABLE:INTEGRITY...

The `STATUS:QUESTIONABLE:INTEGRITY` register monitors hardware failures of the analyzer. It can be queried using the commands

`STATUS:QUESTIONABLE:INTEGRITY:CONDITION?` or

`STATUS:QUESTIONABLE:INTEGRITY[:EVENT]?`

`STATUS:QUESTIONABLE:INTEGRITY` is also the summary register of the lower level

`STATUS:QUESTIONABLE:INTEGRITY:HARDWARE` register.



Refer to the [Chapter 10, "Error Messages and Troubleshooting"](#), on page 1143 for a detailed description of hardware errors including possible remedies.

The bits in the `STATUS:QUESTIONABLE:INTEGRITY` register are defined as follows.

Bit No.	Meaning
2	<p>HARDware register summary</p> <p>This bit is set if a bit is set in the <code>STATUS:QUESTIONABLE:INTEGRITY:HARDWARE</code> register and the associated <code>ENABLE</code> bit is set to 1.</p>

`STATUS:QUESTIONABLE:INTEGRITY:HARDWARE`

The `STATUS:QUESTIONABLE:INTEGRITY:HARDWARE` register can be queried using the commands `STATUS:QUESTIONABLE:INTEGRITY:HARDWARE:CONDITION?` or `STATUS:QUESTIONABLE:INTEGRITY:HARDWARE[:EVENT]?`

The bits in the `STATUS:QUESTIONABLE:INTEGRITY:HARDWARE` register are defined as follows.

Bit No.	Meaning
0	Not used
1	<p>Reference frequency lock failure</p> <p>If an external reference signal is used, the local oscillator is phase locked to a reference signal. This bit is set if this phase locked loop (PLL) fails.</p> <p>For external reference: check frequency and level of the supplied reference signal.</p>
2	<p>Output power unlevelled</p> <p>This bit is set if the level control at one of the ports is unsettled or unstable, possibly due to an external disturbing signal.</p> <p>Change generator level at the port; check external components.</p>
3	<p>Receiver overload protection tripped</p> <p>This bit is set if the analyzer detects an excessive input level at one of the ports. If this condition persists, all internal sources are switched off.</p> <p>Reduce RF input level at the port. Check amplifiers in the external test setup, then switch on the internal source using <code>OUTPUT ON</code>.</p>
4	<p>Problem concerning external switch matrix</p> <p>This bit is set if an external matrix has been configured but cannot be controlled or provides error messages.</p> <p>Check whether the matrix is properly connected and switched on. Check for proper wiring of the interfaces, in particular on input and output. If the LAN or USB interface is configured, disconnect the <code>Direct CTRL</code> plug. Exclude address conflicts when using several external switch matrices or other external devices.</p>
6	<p>Internal communication error</p> <p>This bit is set if an internal error caused the analyzer to perform an automatic hardware reset. The current measurement results are possibly invalid.</p> <p>The bit is automatically cleared at the beginning of the next sweep, no action is required.</p>

Bit No.	Meaning
7	<p>Instrument temperature is too high</p> <p>This bit is set if the analyzer detects that the instrument temperature is too high. Reduce ambient temperature, keep ventilation holes of the casing unobstructed.</p>
8	<p>Oven cold</p> <p>This bit is set if the oven for the internal high precision clock (option B4) is not at its operating temperature. Wait until the oven has been heated up.</p>
9	<p>Unstable level control</p> <p>This bit is set if the analyzer detects an excessive source level at one of the ports. The signal is turned off and the sweep halted. Check signal path for the received wave, especially check external components. Then restart the sweep (<code>INITiate<Ch>[:IMMEDIATE]</code>).</p>
11	<p>Problem concerning external power meter</p> <p>This bit is set if an external power meter has been configured but cannot be controlled or provides error messages. Check whether the power meter is properly connected and switched on. Check the GPIB address; exclude address conflicts when using several external power meters or other equipment.</p>
12	<p>Time grid too close</p> <p>This bit is set if the sweep points for a time sweep are too close, so that the analyzer cannot process the measurement data until the next sweep point starts. Increase stop time, reduce no. of points, increase IF bandwidth. If possible reduce number of partial measurements, e.g. by restricting the number of ports measured.</p>
14	<p>Power settings exceed hardware limits</p> <p>This bit is set if the source power at one of the test ports is too high or too low. Reduce or increase the source power.</p>
15	<p>Detector MEAS time has been internally limited</p> <p>This bit is set if the selected measurement time for a detector (observation time) is too long. If desired, reduce the measurement time or select a smaller IF bandwidth.</p>

7.5.4 Application of the Status Reporting System

The purpose of the status reporting system is to monitor the status of one or several devices in a measuring system. To do this and react appropriately, the controller must receive and evaluate the information of all devices. The following standard methods described in the following sections are used:

- Service request (SRQ) initiated by the measuring device
- Serial poll of all devices in the bus system, initiated by the controller to find out who sent an SRQ and why
- Parallel poll of all devices
- Query of a specific instrument status by commands
- Query of the error queue

7.5.4.1 Service Request

The R&S ZND can send a service request (SRQ) to the controller. Usually this service request causes an interrupt, to which the control program can react appropriately.

Initiating an SRQ

As shown in section [Overview of Status Registers](#), an SRQ is initiated if one or several of bits 2, 3, 4, 5 or 7 of the status byte are set and enabled in the SRE. Each of these bits summarizes the information of a further register, the error queue or the output buffer.

The ENABLE parts of the status registers can be set such that arbitrary bits in an arbitrary status register initiate an SRQ. To use the possibilities of the service request effectively, all bits in the enable registers SRE and ESE must be set to "1".

Example: Use *OPC to generate an SRQ

1. Set bit 0 in the ESE (Operation Complete).
2. Set bit 5 in the SRE (ESB).
3. Insert *OPC in the command sequence (e.g. at the end of a sweep).

When all commands preceding *OPC have been completed, the instrument generates an SRQ.

Example: Generate an SRQ when a limit is exceeded

1. Set bit 3 in the SRE (summary bit of the `STATUS:QUESTIONABLE` register, set after `STATUS:PRESet`)
2. Set bit 10 in the `STATUS:QUESTIONABLE:ENABLE` register (summary bit of the `STATUS:QUESTIONABLE:LIMIT1` register)
3. Set bit 1 in the `STATUS:QUESTIONABLE:LIMIT1:ENABLE` register

The R&S ZND generates an SRQ when the event associated with bit 1 of the `STATUS:QUESTIONABLE:LIMIT1:ENABLE` register occurs, i.e. when any point on the first trace fails the limit check.

Example: Find out which event caused an SRQ

The procedure to find out which event caused an SRQ is analogous the procedure to generate an SRQ:

1. `STB?` (query the contents of the status byte in decimal form)
If bit 3 (`QUESTIONABLE` summary bit) is set, then:
2. `STAT:QUES:EVENT?` (query `STATUS:QUESTIONABLE` register)
If bit 10 (`QUESTIONABLE:LIMIT1` summary bit) is set, then:

3. Query `STAT:QUES:LIMit1:EVENT?` (query `STATus:QUEStionable:LIMit1` register)
If bit 1 is set, then the first trace failed the limit check.



The SRQ is the only possibility for the instrument to become active on its own. Each controller program should set the instrument such that a service request is initiated in the case of malfunction. The program should react appropriately to the service request.

7.5.4.2 Serial Poll

In a serial poll, the controller queries the `STatus Bytes` of the devices in the bus system one after another. The query is made via interface messages, so it is faster than a poll using `*STB?`.

The serial poll method is defined in IEEE 488.1 and used to be the only standard possibility for different instruments to poll the status byte. The method also works for instruments which do not adhere to SCPI or IEEE 488.2.

The serial poll is used to obtain a fast overview of the state of several instruments connected to the controller.

7.5.4.3 Parallel Poll

In a parallel poll, up to eight instruments are simultaneously requested by the controller with a single command to transmit 1 bit of information each on the data lines, i.e., to set the data line allocated to each instrument to a logical "0" or "1".

In addition to the `SRE` register, which determines the conditions under which an SRQ is generated, there is a `Parallel Poll Enable (PPE)` register. This register is ANDed with the `STB` bit by bit, considering bit 6 as well. The results are ORed, the result is possibly inverted and then sent as a response to the parallel poll of the controller. The result can also be queried without parallel poll with the command `*IST?`.

The parallel poll method is used to find out quickly which one of the instruments connected to the controller has sent a service request. To this effect, `SRE` and `PPE` must be set to the same value.

7.5.4.4 Query of an Instrument Status

Each part of any status register can be read using queries. There are two types of commands:

- The common commands `*ESR?`, `*IDN?`, `*IST?`, `*STB?` query the higher-level registers.
- The commands of the `STATus` system query the SCPI registers (e.g. `STATus:OPERation...`)

All queries return a decimal number which represents the bit pattern of the status register. This number is evaluated by the controller program.

Queries are usually used after an SRQ to obtain more detailed information on its cause.

Decimal representation of a bit pattern

The STB and ESR registers contain 8 bits, the SCPI registers 16 bits. The contents of a status register is keyed and transferred as a single decimal number. To make this possible, each bit is assigned a weighted value. The decimal number is calculated as the sum of the weighted values of all bits in the register that are set to 1.

Bits	0	1	2	3	4	5	6	7	...
Weight	1	2	4	8	16	32	64	128	...

Example: The decimal value 40 = 32 + 8 indicates that bits no. 3 and 5 in the status register (e.g. the QUEStionable status summary bit and the ESB bit in the STB) are set.

7.5.4.5 Error Queue

Each error state in the instrument leads to an entry in the error queue, whose current number of entries can be queried using `SYSTem:ERRor:COUnT?`. The entries of the error queue are detailed plain text error messages that can be queried via remote control using `SYSTem:ERRor[:NEXT]?` or `SYSTem:ERRor:ALL?`. Each call of `SYSTem:ERRor[:NEXT]?` provides one entry from the error queue. If no error messages are stored there any more, the instrument responds with 0, "No error".

The error queue should be queried after every SRQ in the controller program as the entries describe the cause of an error more precisely than the status registers. Especially in the test phase of a controller program the error queue should be queried regularly since faulty commands from the controller to the instrument are recorded there as well.

7.5.5 Reset Values of the Status Reporting System

The table below indicates the effects of various commands upon the status reporting system of the R&S ZND.

DCL, SDC (Device Clear, Selected Device Clear)

Event	Switching on supply voltage Power-On-Status-Clear		DCL, SDC (Device Clear, Selected Device Clear)	*RST or SYS-Tem:PRE-Set:ALL	STA-Tus:PRE-Set	*CLS
	0	1				
Effect	0	1				
Clear STB, ESR		yes				yes
Clear SRE, ESE		yes				
Clear PPE		yes				

Event	Switching on supply voltage Power-On-Status-Clear		DCL, SDC (Device Clear, Selected Device Clear)	*RST or SYS-Tem:PRE-Set:ALL	STA-Tus:PRE-Set	*CLS
Clear EVENT parts of the registers		yes				yes
Clear ENABLE parts of all OPERATION and QUESTIONABLE registers, Fill ENABLE parts of all other registers with "1".		yes			yes	
Fill PTRansition parts with "1" Clear NTRansition parts		yes			yes	
Clear error queue	yes	yes				yes
Clear output buffer	yes	yes	yes	1)	1)	1)
Clear command processing and input buffer	yes	yes	yes			

1) Every command being the first in a command line, i.e. immediately following a <PROGRAM MESSAGE TERMINATOR> clears the output buffer.

8 Command Reference

This chapter describes all common commands and SCPI commands implemented by the analyzer.



Validity of the command set

The commands reported in this chapter are valid for vector network analyzers with any number of ports. However, some of the program examples assume that more than 2 ports are available. In most cases, a simple adjustment of the port suffixes or parameters ensures compatibility with 2-port analyzers.

Compatibility with R&S ZVB and older instruments

The SCPI command set for the R&S ZND vector network analyzer has been designed for compatibility with network analyzers R&S ZVA and R&S ZVB. A special subset of commands has been implemented for compatibility with older analyzers of the R&S ZVR family. These commands are listed in [Chapter 8.5, "R&S ZVR/ZVABT Compatible Commands"](#), on page 1087.

If you want to make full use of the R&S ZND features but do not need R&S ZVR compatibility, you should use the commands listed in [Chapter 8.3, "SCPI Command Reference"](#), on page 597.

8.1 Special Terms and Notation

This section explains the meaning of special syntax elements used in the SCPI command reference sections.

The following information is provided in the reference sections:

- Complete command syntax and parameter list
- Description of the command and its relationship with other commands
- List and description of the parameters with their numerical ranges, default values and default units
- Supported command types (setting command, query). If nothing is mentioned, the command can be used to write **and** read data (setting command and query).
- Program example

The SCPI conformance information is stated at the beginning of each section. Unless otherwise stated, the commands are device-specific.

The commands are generally arranged in alphabetical order. Commands with similar function (e.g. a pair of `...START` and `...STOP` commands) may be described in a common section, which in some instances disrupts the strict alphabetical order.

8.1.1 Upper/Lower Case

Upper/lower case characters characterize the long and short form of the mnemonics in a command. The short form consists of all uppercase characters, the long form of all uppercase plus all lowercase characters. It is recommended to use either the short form or the long form; mixed forms are not always recognized. The R&S ZND itself does not distinguish uppercase and lowercase characters.

8.1.2 Special Characters

The following special characters are frequently used in the command description:

- **|** A vertical stroke characterizes alternative parameter settings. Only one of the parameters separated by | must be selected.
- **[]** Mnemonics in square brackets can be omitted when composing the command header. The complete command must be recognized by the instrument for reasons of compatibility with the SCPI standard. Parameters in square brackets are optional as well. They may be used in some application contexts, omitted in others.
- **{ }** Braces or curly brackets enclose one or more parameters that may be included zero or more times.

8.1.3 Parameters

Many commands are supplemented by a parameter or a list of parameters. Parameters either provide alternative options (setting a or setting b or setting c ..., see special character "|"), or they form a list separated by commas (setting x, y).

- **<Parameter1>, <Parameter2>...**: In the command tables and lists, parameters are generally described by a name (Parameter1, Parameter2...) written in angle brackets (<>). In an application program, <Parameter1>, <Parameter2>... must be replaced by one of the possible settings reported in the detailed parameter description.

Example: `CONTRol:AUXiliary:C[:DATA] <DecValue>`

with <DecValue> = 0 to 255

--> possible command syntax: `CONTRol:AUXiliary:C:DATA 1`

- **NAN (Not A Number)** (as a returned value) is generally used to represent missing data, e.g. if a portion of a trace has not been acquired yet. It is also returned after invalid mathematical operations such as division by zero. As defined in the SCPI standard, NAN is represented as 9.91 E 37.
- **INV (INValid)** is returned e.g. if a limit check is performed without defining the appropriate tolerance values.

8.1.4 Numeric Suffixes

Symbols in angular brackets (<Ch>, <Chn>, <Mk>...) are numeric suffixes. Numeric suffixes are replaced by integer numbers to distinguish various items of the same type.

The analyzer provides numeric suffixes for channels, traces, ports, markers etc. If unspecified, a numeric suffix is replaced by 1.

The number of ports depends on the analyzer model. No restrictions apply to number of markers, channel, trace, and diagram suffixes.

In remote control, one active trace can be selected for each channel; see [Chapter 7.3.2, "Active Traces in Remote Control"](#), on page 573. This concept simplifies the remote control command syntax, because it allows the active trace in a particular channel to be referenced by means of the channel suffix.

To keep the syntax transparent,

- <Ch> is used for channel settings (<Ch> refers to the configured channel)
- <Chn> is used for trace settings (<Chn> refers to the channel whose active trace is configured)

8.2 Common Commands

Common commands are described in the IEEE 488.2 (IEC 625-2) standard. These commands have the same effect and are employed in the same way on different devices. The headers of these commands consist of "*" followed by three letters. Many common commands are related to the status reporting system; see [Chapter 7.5, "Status Reporting System"](#), on page 580.

Table 8-1: List of common commands

Command	Parameters / Remarks	Short Description
*CLS Clear Status	– / no query	Sets the status byte (STB), the standard event register (ESR) and the EVENT part of the QUESTIONable and the OPERATION register to zero. The command does not alter the mask and transition parts of the registers. It clears the output buffer and the tooltip error messages for remote control.
*ESE Event Status Enable	0...255	Sets the event status enable register to the value indicated. The query *ESE? returns the contents of the event status enable register in decimal form.
*ESR? Event Status Read	– / query only	Returns the contents of the event status register in decimal form (0 to 255) and sets the register to zero.
*IDN? Identification Query	– / query only	Queries the instrument identification string of the R&S ZND, including the manufacturer, the instrument type, its serial number, and the software revision. For the R&S ZND, the response is of the form Rohde-Schwarz,ZND-<Ports>Port,<Order and Serial No.>,<FW_Version>, e.g. Rohde-Schwarz,ZND-2Port,1328517092100005,2.90.1.125. The IDN information is editable; see "Define *IDN + *OPT..." on page 540.
*IST? Individual Status query	– / query only	Returns the contents of the IST flag in decimal form (0 1). The IST-flag is the status bit which is sent during a parallel poll.
*OPC Operation Complete	–	Sets bit 0 in the event status register when all preceding commands have been executed. This bit can be used to initiate a service request. The query form writes a "1" to the output buffer when all preceding commands have been executed. This logic is used for command synchronization.

Command	Parameters / Remarks	Short Description
*OPT? OPTion identification query	– query only	Queries the options included in the instrument and returns a list of the options installed. The response consists of arbitrary ASCII response data according to IEEE 488.2. The options are returned at fixed positions in a comma-separated string. A zero is returned for options that are not installed. The OPT information is editable; see "Define *IDN + *OPT..." on page 540.
*PCB Pass Control Back	0...30 / no query	Indicates the controller address to which GPIB bus control is returned after termination of the triggered action.
*PRE Parallel poll Register Enable	0...255	Sets parallel poll enable register to the value indicated. Query *PRE? returns the contents of the parallel poll enable register in decimal form.
*PSC Power on Status Clear	0 1	Determines whether the contents of the ENABLE registers is maintained or reset when the instrument is switched on. *PSC = 0 causes the contents of the status registers to be maintained. Thus a service request can be triggered on switching on in the case of a corresponding configuration of status registers ESE and SRE. *PSC = 1 resets the registers. Query *PSC? reads out the contents of the power-on-status-clear flag. The response can be 0 or 1.
*RST Reset	– / no query	Sets the instrument to a defined default status. The command is equivalent to <code>SYSTem:PRESet [:DUMMy]</code> . The *RST value of each command is reported in the reference description. See also <code>SYSTem:PRESet:SCOPE</code> .
*SRE Service Request Enable	0...255	Sets the service request enable register to the value indicated. Bit 6 (MSS mask bit) remains 0. This command determines under which conditions a service request is triggered. The query *SRE? returns the contents of the service request enable register in decimal form. Bit 6 is always 0.
*STB? Status Byte query	– / query only	Reads the contents of the status byte in decimal form.
*TRG Trigger	– / no query	Triggers all actions waiting for a trigger event. *TRG generates a manual trigger signal. This common command complements the <code>TRIGger...</code> commands of the analyzer.
*WAI Wait to continue	– / no query	Prevents servicing of the subsequent commands until all preceding commands have been executed and all signals have settled.

8.3 SCPI Command Reference

The following sections provide detailed reference information on the instrument control commands implemented by the R&S ZND network analyzer.

- [CALCulate Commands](#)..... 598
- [CONFigure Commands](#).....783
- [CONTRol Commands](#).....791
- [DIAGnostic Commands](#).....800
- [DISPlay Commands](#).....802
- [FORMat Commands](#)..... 828
- [HCOPy Commands](#).....830
- [INITiate Commands](#)..... 835
- [INSTrument Commands](#)..... 838
- [MEMory](#).....839

•	MMEMory Commands	841
•	OUTPut Commands	878
•	PROGram Commands	883
•	[SENSE:] Commands	886
•	SOURce Commands	989
•	STATus Commands	1015
•	SYSTem Commands	1018
•	TRACe Commands	1057
•	TRIGger Commands	1060

8.3.1 CALCulate Commands

The `CALCulate...` commands perform post-acquisition data processing. Functions in the `SENSe` subsystem are related to data acquisition, while the `CALCulate` subsystem operates on the data acquired by a `SENSe` function.

8.3.1.1 CALCulate:CLIMits...

The `CALCulate:CLIMits...` commands control the composite limit check.

CALCulate:CLIMits:FAIL?

Returns a 0 or 1 to indicate whether or not a global, composite limit check on several traces has failed.

Since V2.20 of the R&S ZND FW the result is automatically recalculated whenever a relevant setting is changed, i.e. a subsequent query will return the updated limit violation state.

Example:

```
*RST; CALC:LIM:CONT 1 GHZ, 2 GHZ
```

Define an upper limit line segment in the stimulus range between 1 GHz and 2 GHz, using default response values.

```
CALC:LIM:STAT ON; FAIL?
```

Switch the limit check on and query the result.

```
CALC:CLIM:FAIL?
```

Query the result for the composite limit check. As only one trace is tested, the response should be equal to the previous response.

Usage: Query only

Manual operation: See "[Global Check](#)" on page 307

8.3.1.2 CALCulate:CALValidate...

Commands related to [Calibration Validation](#).

CALCulate:CALValidate:CHARacteriza <String>

Selects the CalU characterization to be used for the cal validation.

Use `CALCulate:CALValidate:STANdard` to select the CalU standard to be used for the validation.

Parameters:

<String> *RST: 'Factory'

Manual operation: See "[Characterization](#)" on page 400

CALCulate:CALValidate:RESPonse:MAGNitude:LOWer <Port>, <Value>

CALCulate:CALValidate:RESPonse:MAGNitude:UPPer <Port>, <Value>

Defines the maximum magnitude deviations from the reference characterization S-parameters that are allowed during cal validation.

Use `CALCulate:CALValidate:CHARacteriza` to select the reference characterization.

Parameters:

<Port> Physical analyzer port no.

<Value> *RST: -0.2 (LOWer) | +0.2 (UPPer)
Default unit: dB

Manual operation: See "[Validation Limits](#)" on page 400

CALCulate:CALValidate:RESPonse:PHASe:LOWer <Port>, <Value>

CALCulate:CALValidate:RESPonse:PHASe:UPPer <Port>, <Value>

Defines the maximum phase deviations from the reference characterization S-parameters that are allowed during cal validation.

Use `CALCulate:CALValidate:CHARacteriza` to select the reference characterization.

Parameters:

<Port>

<Value> *RST: -2 (LOWer) | +2 (UPPer)
Default unit: degrees

Manual operation: See "[Validation Limits](#)" on page 400

CALCulate:CALValidate:RUN

Runs the cal validation with its configured settings.

Usage: Event

Manual operation: See "[Validate](#)" on page 399

CALCulate:CALValidate:STANdard <Standard>

Selects the CalU standard to be used for cal validation.

Parameters:

<Standard> OPEN | SHORt | MATCh

8.3.1.3 CALCulate:DATA...

The `CALCulate:DATA...` commands provide access to the results of a measurement.

**Data format**

The trace data is transferred in either ASCII or block data (REAL) format, depending on the `FORMat[:DATA]` setting. If block data format is used, it is recommended to select EOI as a receive terminator (`SYSTem:COMMunicate:GPIB[:SELF]:RTERminator EOI`).

<code>CALCulate:DATA:ALL?</code>	600
<code>CALCulate:DATA:DALL?</code>	601
<code>CALCulate:DATA:TRACe</code>	601
<code>CALCulate<Ch>:DATA:CALL</code>	601
<code>CALCulate<Ch>:DATA:CALL:CATalog?</code>	603
<code>CALCulate<Ch>:DATA:CHANnel:ALL?</code>	603
<code>CALCulate<Ch>:DATA:CHANnel:DALL?</code>	603
<code>CALCulate<Ch>:DATA:MDATa:INTerpolate</code>	604
<code>CALCulate<Ch>:DATA:SGRoup?</code>	604
<code>CALCulate<Chn>:DATA</code>	604
<code>CALCulate<Chn>:DATA:NSWeep[:LAST]?</code>	607
<code>CALCulate<Chn>:DATA:NSWeep:COUNT?</code>	608
<code>CALCulate<Chn>:DATA:NSWeep:FIRSt?</code>	608
<code>CALCulate<Chn>:DATA:STIMulus?</code>	609

CALCulate:DATA:ALL? <Format>[, <RecallSet>]

Reads the current response values of all traces of the referenced recall set.

Query parameters:

<Format> FDATA | SDATa | MDATa
 Output format for the S-parameter data, see
 `CALCulate<Chn>:DATA`.

<RecallSet> Recall set name; if omitted the active recall set is used

Return values:

<Data> Response values either in ASCII or block data format, depending on the current `FORMat[:DATA]` setting.

Example: See `CALCulate<Chn>:DATA`

Usage: Query only

CALCulate:DATA:DALL? <Format>

Reads the current response values of all data traces of the current recall set. Use [CALCulate:DATA:ALL?](#) to query data traces and memory traces.

Query parameters:

<Format> FDATa | SDATa | MDATa
Output format for the S-parameter data, see [CALCulate<Chn>:DATA](#).

Return values:

<Data> Response values either in ASCII or block data format, depending on the current [FORMat\[:DATA\]](#) setting.

Example: Analogous to [CALCulate:DATA:DALL?](#); see [CALCulate<Chn>:DATA](#).

Usage: Query only

CALCulate:DATA:TRACe <TraceName>, <Format>, <Data>...

The query gets the trace data of an arbitrary (not necessarily the active) trace, referenced by its trace name <TraceName>.

The "set direction" allows to import formatted or unformatted trace data to an existing trace (data access point 3 or 2 in [Chapter 5.1.5, "Data Flow"](#), on page 77).

Note

- Unformatted trace data (SDATa) can only be imported to memory traces
- Formatted trace data (FDATa) can only be imported to "live" traces if the related channel is in single sweep mode ([INITiate<Ch>:CONTinuous OFF](#)). Before the import, the target trace must be prepared according to the settings used during export. Any request for new data from the hardware ("Restart Sweep" in single sweep mode or switching to continuous sweep mode) discards imported data and switches back the display to measured data.

Parameters:

<TraceName> String parameter containing the trace name

<Format> FDATa | SDATa | MDATa | NCDat | UCData
Data format; see [Table 8-2](#).

<Data> Trace data for FDATa | SDATa import either in ASCII or block data format, depending on the current [FORMat\[:DATA\]](#) setting. The column order must match the one used during export.

Example: See [CALCulate<Chn>:DATA](#).

CALCulate<Ch>:DATA:CALL <Format>, <Data>...

The query reads the current response values of all S-parameter data traces at channel <Ch>'s data access point <DACPoint>.

If a full n-port system error correction is active in the related channel, the command reads the full nxn S-matrix of the calibrated ports (there is no need to create or display the S-parameter traces). Use `CALCulate<Ch>:DATA:CALL:CATalog?` to query the available traces.

The "set direction" allows you to import measurement data at the "Fixture Simulation Input" data access point (see [Chapter 5.1.5, "Data Flow"](#), on page 77).

Note

- Importing data is only supported in single sweep mode (`INITiate<Ch>:CONTinuous OFF`)
- Before importing data, the channel must be configured with the same settings that were used during export (user calibration, balanced port configuration, stimulus axis etc.). Furthermore the switch matrix configuration must match.
- After importing data, "downstream" parameters in the data flow can be changed and their effect is shown directly
- Any request for new data from the hardware (Restart Sweep in single sweep mode or switching to continuous sweep mode) discards imported data and switches back the display to measured data

Suffix:

<Ch> Channel number

Parameters:

<Format> SDATa | FSIData

SDATa

Output as unformatted trace data; see `CALCulate<Chn>:DATA`. Query only.

FSIData

Output or input at "Fixture Simulation Input" data access point.

<Data> Trace data either in ASCII or block data format, depending on the current `FORMat [:DATA]` setting. The column order must match the one used during export.

Example:

Suppose that a TOSM calibration for ports 1 and 2 is active in channel no. 1.

```
CALCulate:DATA:CALL:CATalog?
```

Query the traces available for `CALCulate<Ch>:DATA:CALL?`.

The response is 'S11, S12, S21, S22'.

```
CALCulate:DATA:CALL? SDATa
```

Return the complex response values of all traces. The traces in the catalog list are read one after another: The response array contains n (number of points) pairs of real and imaginary values for S_{11} , followed by n pairs of values for S_{12} , S_{21} , and S_{22} .

CALCulate<Ch>:DATA:CALL:CATalog?

Returns all traces which are available for `CALCulate<Ch>:DATA:CALL` in channel no. <Ch>. The response is a string parameter with all S-parameter traces in the current channel or in the active system error correction; see example.

Suffix:

<Ch> Channel number

Example:

See `CALCulate<Ch>:DATA:CALL`

Usage:

Query only

CALCulate<Ch>:DATA:CHANnel:ALL? <Format>

Reads the current response values of all traces of the selected channel.

Suffix:

<Ch> Channel number

Query parameters:

<Format> FDATa | SDATa | MDATa
Output format for the S-parameter data, see `CALCulate<Chn>:DATA`.

Return values:

<Data> Trace data either in ASCII or block data format, depending on the current `FORMat [:DATA]` setting.

Usage:

Query only

CALCulate<Ch>:DATA:CHANnel:DALL? <Format>

Reads the current response values of all data traces of the selected channel. Use `CALCulate<Ch>:DATA:CHANnel:ALL?` to query data traces and memory traces.

Suffix:

<Ch> Channel number

Query parameters:

<Format> FDATa | SDATa | MDATa
Output format for the S-parameter data, see `CALCulate<Chn>:DATA`.

Return values:

<Data> Trace data either in ASCII or block data format, depending on the current `FORMat [:DATA]` setting.

Usage:

Query only

CALCulate<Ch>:DATA:MDATa:INTerpolate

Uses linear inter-/extrapolation to "regrid" all memory traces of the related channel to the channel's current stimulus values.

Suffix:

<Ch> Channel number

Usage:

Event

CALCulate<Ch>:DATA:SGRoup? <Format>

Reads the current response values of all S-parameters associated to a group of logical ports (S-parameter group). The S-parameter group must be created before using [CALCulate<Ch>:PARAmeter:DEFine:SGRoup](#).

Suffix:

<Ch> Channel number of the previously defined S-parameter group.

Query parameters:

<Format> FDATa | SDATa | MDATa
Output format for the S-parameter data, see [CALCulate<Chn>:DATA](#) on page 604.

Example:

See [CALCulate<Ch>:PARAmeter:DEFine:SGRoup](#)

Usage:

Query only

CALCulate<Chn>:DATA <Format>, <Data>...**CALCulate<Chn>:DATA? <Format>**

The query reads the response values of the selected channel's active trace or reads error terms of the selected channel.

The "set command" either imports formatted or unformatted trace data to the selected channel's active trace (see [Chapter 5.1.5, "Data Flow"](#), on page 77) or writes error terms of the selected channel.

Note

- The data format is parameter-dependent; see tables below. The unit is the default unit of the measured parameter; see [CALCulate<Ch>:PARAmeter:SDEFine](#).
- Unformatted trace data (SDATa) can only be imported to memory traces
- Formatted trace data (FDATa) can only be imported to "live" traces if the related channel is in single sweep mode ([INITiate<Ch>:CONTInuous OFF](#)).
Before the import, the target trace must be prepared according to the settings used during export. Any request for new data from the hardware ("Restart Sweep" in single sweep mode or switching to continuous sweep mode) discards imported data and switches back the display to measured data.

Suffix:

<Chn> Channel number used to identify the active trace

Parameters:

<Data> Trace data either in ASCII or block data format, depending on the current `FORMat [:DATA]` setting.

Parameters for setting and query:

<Format> FDATa | SDATa | MDATa | NCDat | UCData | SCORr1 | SCORr2 | SCORr3 | SCORr4 | SCORr5 | SCORr6 | SCORr7 | SCORr8 | SCORr9 | SCORr10 | SCORr11 | SCORr12 | SCORr13 | SCORr14 | SCORr15 | SCORr16 | SCORr17 | SCORr18 | SCORr19 | SCORr20 | SCORr21 | SCORr22 | SCORr23 | SCORr24 | SCORr25 | SCORr26 | SCORr27

See list of parameters below.

Example:

```
*RST; SWE:POIN 20
```

Create a trace with 20 sweep points, making the created trace the active trace of channel 1 (omitted optional mnemonic `SENSe1`).

```
CALC:DATA? FDAT
```

Query the 20 response values of the created trace. In the `FDATa` setting, 20 comma-separated ASCII values are returned.

```
CALC:DATA:STIM?
```

Query the 20 stimulus values of the created trace. 20 comma-separated ASCII values are returned.

```
CALC2:PAR:SDEF 'Trc2', 'S11'
```

Create a second trace in a new channel no. 2. The second trace does not become the active trace and is not displayed.

```
CALC:DATA:TRAC? 'Trc2', FDAT
```

Query the response values of the second (non-active) trace. 20 comma-separated ASCII values are returned.

```
CALC:DATA:ALL? FDAT
```

Query the response values of all traces. 40 comma-separated ASCII values are returned.

Example:**Writing memory traces**

```
*RST; SWE:POIN 3
```

Create a data trace 'Trc1' with 3 sweep points, making the created trace the active trace of channel 1 (omitted optional mnemonic `SENSe1`).

```
TRAC:COPY 'MemTrc1','Trc1'; :CALC:PAR:SEL 'MemTrc1'
```

Copy the data trace to a memory trace and select the memory trace as an active trace.

```
CALC:DATA SDAT, 1,2, 3,4, 5,6
```

Write numbers (1,2), (3,4), (5,6) to the memory trace.

```
CALC:DATA? SDAT
```

Query the memory trace. The response is 1,2,3,4,5,6.

```
FORM REAL, 32
```

Change the data format to 4-byte block data.

```
CALC:DATA SDAT, #224123456789012345678901234
```

Write 24 bytes (= 4 * 2 * 3 bytes) of data to the memory trace.

The following parameters are related to trace data (see also diagram in [Chapter 5.1.5, "Data Flow"](#), on page 77):

Table 8-2: Data format identifiers used in the CALCulate:DATA... commands

FDATA	Formatted trace data, according to the selected trace format (CALCulate<Chn>:FORMat). One value per trace point for Cartesian diagrams, two values for polar diagrams. [Data access point 6]
SDATA	Unformatted trace data: real and imaginary part of each measurement point. Two values per trace point irrespective of the selected trace format. The trace mathematics is not taken into account. [Data access point 4]
MDATA	Unformatted trace data (see SDATA) after evaluation of trace mathematics. [Data access point 5]
NCDATA	Factory calibrated trace data: the values are obtained right after applying the factory calibration but before applying a user-defined calibration (if any). [Data access point 1]
UCDATA	Uncalibrated trace data. [Data access point 0] Note: <ul style="list-style-type: none"> the respective trace must represent a wave quantity or ratio driving and receiving port must not be on a switch matrix Otherwise an error occurs.

The following parameters denote the error terms generated during a calibration.

Table 8-3: Error terms in the CALCulate:DATA... commands

Error Term	Description	Receive Ports (S-parameter)
SCORr1, ..., SCORr12	2-port error terms; see [SENSe<Ch>:]CORRection:DATA.	1 and 2 (S11, S12, S21, S22)
SCORr13	Directivity	3 (S33)
SCORr14	Source match	3 (S33)
SCORr15	Reflection tracking	3 (S33)
SCORr16	Isolation	3 (S31)
SCORr17	Load match	3 (S31)
SCORr18	Transmission tracking	3 (S13)
SCORr19	Isolation	1 (S13)
SCORr20	Load match	1 (S13)
SCORr21	Transmission tracking	1 (S13)
SCORr22	Isolation	3 (S32)
SCORr23	Load match	3 (S32)
SCORr24	Transmission tracking	3 (S32)
SCORr25	Isolation	2 (S23)

Error Term	Description	Receive Ports (S-parameter)
SCORr26	Load match	2 (S23)
SCORr27	Transmission tracking	2 (S23)

Note: The error terms are channel-specific; they apply to the active calibration of channel no. <Chn> or to the factory calibration (if no channel calibration is active). For the factory calibration, the query form is allowed only (no change of factory calibration data).

Tip: Use the generalized command `[SENSe<Ch>:]CORRection:CDATa` to read or write error terms for arbitrary analyzer ports. For additional programming examples refer to [Chapter 9.2.5.3, "Saving and Recalling Error Terms"](#), on page 1138.

CALCulate<Chn>:DATA:NSWeep[:LAST]? <Format>, <RvCount>

Reads the response values of a trace acquired in single sweep mode (`INITiate<Ch>:CONTinuous OFF`). The trace can be any of the traces acquired during the single sweep cycle.

Tip:

- This command can only be used for `[SENSe<Ch>:]SWEep:COUNT > 1`.
- Ensure that the single sweep is terminated before using this command, otherwise the results of the trace count will be unpredictable (see example below). Alternatively, use the `CALCulate<Chn>:DATA:NSWeep:FIRSt?` command.

Suffix:

<Chn> Channel number used to identify the active trace

Query parameters:

<Format> SDATa

Read unformatted sweep data (fixed parameter): Returns the real and imaginary part of each measurement point (2 values per trace point, irrespective of the selected trace format).

<RvCount> Number of sweep to be read. 1 denotes the last sweep acquired, 2 denotes the second-last and so forth.

Range: 1 to sweep count defined via `[SENSe<Ch>:]SWEep:COUNT`

Example:

```
SWE:COUN 10
```

Define the number of sweeps (10) to be measured in single sweep mode.

```
INIT:CONT OFF; :INIT; *OPC?
```

Activate single sweep mode and start a single sweep sequence in channel no. 1. Wait until the single sweep sequence is complete.

```
CALC:DATA:NSW? SDAT, 3
```

Query the results of the 8th sweep.

See also [Chapter 9.2.4.3, "Retrieving the Results of Previous Sweeps"](#), on page 1133.

Usage: Query only

CALCulate<Chn>:DATA:NSweep:COUNT?

Reads the number of completed sweeps in single sweep mode (`INITiate<Ch>:CONTinuous OFF`). The trace can be any of the traces acquired during the single sweep cycle.

Tip:

This command can only be used for `[SENSe<Ch>:]SWEep:COUNT > 1`.

Suffix:

<Chn> Channel number used to identify the active trace

Example: See `CALCulate<Chn>:DATA:NSweep:FIRSt?`

Usage: Query only

CALCulate<Chn>:DATA:NSweep:FIRSt? <Format>, <FwCount>[, <FwCountEnd>]

Reads the response values of a trace or a consecutive group of traces acquired in single sweep mode (`INITiate<Ch>:CONTinuous OFF`).

Tip:

This command can only be used for `[SENSe<Ch>:]SWEep:COUNT > 1`.

Suffix:

<Chn> Channel number used to identify the active trace

Query parameters:

<Format> SDATa

Read unformatted sweep data (fixed parameter): Returns the real and imaginary part of each measurement point (2 values per trace point irrespective of the selected trace format).

<FwCount> Number of first sweep to be read. 1 denotes the first sweep acquired, 2 denotes the second and so forth. The sweep count in single sweep mode is defined via `[SENSe<Ch>:]SWEep:COUNT`.

Range: 1 to sweep count

<FwCountEnd> Number of last sweep to be read. If this parameter is omitted, it is implicitly set to <FwCount> (a single sweep is read).

Range: <FwCount> to sweep count

Return values:

<Data> Response values either in ASCII or block data format, depending on the current `FORMat[:DATA]` setting.

Example: `SWE:COUN 10`
 Define the number of sweeps (10) to be measured in single sweep mode.
`INIT:CONT OFF; :INIT;`
 Activate single sweep mode and start a single sweep sequence in channel no. 1. No synchronization is necessary.
`if (CALC:DATA:NSW:COUN? > 4)`
`CALC:DATA:NSW:FIRS? SDAT, 5`
 Wait until 5 sweeps have been measured, then query the results of the 5th sweep.
 See also [Chapter 9.2.4.3, "Retrieving the Results of Previous Sweeps"](#), on page 1133.

Usage: Query only

CALCulate<Chn>:DATA:STIMulus?

Reads the stimulus values of the active data or memory trace.

Suffix:
 <Chn> Channel number used to identify the active trace

Example: See [CALCulate<Chn>:DATA](#)

Usage: Query only

8.3.1.4 CALCulate:DLINe...

The `CALCulate:DLINe...` commands control the horizontal line used to mark and retrieve response values (display line).

[CALCulate<Chn>:DLINe.....](#)609
[CALCulate<Chn>:DLINe:STATe.....](#)610

CALCulate<Chn>:DLINe <Position>

Defines the position (response value) of the horizontal line.

Suffix:
 <Chn> Channel number used to identify the active trace

Parameters:
 <Position> See list of parameters below.
 Default unit: NN

Example: `*RST; :CALC:DLIN 10`
 Define the position of the horizontal line in the default dB Mag diagram at +10 dB.
`CALC:DLIN:STAT ON`
 Display the defined horizontal line.

Manual operation: See ["Response Value"](#) on page 322

CALCulate<Chn>:DLINe:STATe <Boolean>

Switches the horizontal line on or off.

Suffix:

<Chn> Channel number used to identify the active trace

Parameters:

<Boolean> ON | OFF - horizontal line on or off
*RST: OFF

Example: See [CALCulate<Chn>:DLINe](#)

Manual operation: See "Show Horiz. Line" on page 322

8.3.1.5 CALCulate:FILTer[:GATE]...

The `CALCulate:FILTer[:GATE]...` commands define the properties of the time gate which is used to optimize the time domain response.

CALCulate:FILTer[:GATE]:TIME:AOFFset	610
CALCulate<Chn>:FILTer[:GATE]:TIME[:TYPE]	611
CALCulate<Chn>:FILTer[:GATE]:TIME:CENTer	611
CALCulate<Chn>:FILTer[:GATE]:TIME:DCHebyshev	612
CALCulate<Chn>:FILTer[:GATE]:TIME:SHAPE	612
CALCulate<Chn>:FILTer[:GATE]:TIME:SHOW	613
CALCulate<Chn>:FILTer[:GATE]:TIME:SPAN	613
CALCulate<Chn>:FILTer[:GATE]:TIME:START	614
CALCulate<Chn>:FILTer[:GATE]:TIME:STOP	614
CALCulate<Chn>:FILTer[:GATE]:TIME:STATe	614
CALCulate<Chn>:FILTer[:GATE]:TIME:WINDow	615

CALCulate:FILTer[:GATE]:TIME:AOFFset <Boolean>

Activates the operating mode where the time gate is moved in the opposite direction when the "Delay" setting is changed.

Parameters:

<Boolean> ON | OFF - enable or disable "Adjust Time Gate".
*RST: OFF

Example:

```
*RST; :CALCulate1:TRANSform:TIME:STATE ON
CALCulate1:FILTer:GATE:TIME:STATE ON; SHOW ON
Activate time domain representation and a time gate in channel
no. 1. Display the time gate
CALCulate1:FILTer:GATE:TIME:START 2ns; STOP 3
ns
Restrict the time gate to the time interval between 2 ns and 3 ns.
CALCulate:FILTer:GATE:TIME:AOFFset ON
Activate an offset of the time gate according to a new delay set-
ting.
SENSE1:CORRection:EDELay1:TIME 1ns
Specify a 1 ns delay at port 1.
CALCulate1:FILTer:GATE:TIME:START?; STOP?
Query the time gate position. The response is 1E-009;2E-009.
```

Manual operation: See "[Adjust Time Gate](#)" on page 445

CALCulate<Chn>:FILTer[:GATE]:TIME[:TYPE] <TimeGateFilter>

Selects the time gate filter type, defining what occurs to the data in the specific time region.

Suffix:

<Chn> Channel number used to identify the active trace

Parameters:

<TimeGateFilter> BPASs | NOTCh

BPASs

Band pass filter: Pass all information in specified time region and reject everything else

NOTCh

Notch filter: Reject all information in specified time region and pass everything else

```
*RST: BPASs
```

Example:

```
*RST; :CALC:FILT:TIME:STAT ON
Reset the instrument and enable the time gate.
CALC:FILT:TIME NOTCh
Select a notch filter in order to reject unwanted pulses.
```

Manual operation: See "[Bandpass / Notch](#)" on page 285

CALCulate<Chn>:FILTer[:GATE]:TIME:CENTer <CenterTime>

Defines the center time of the time gate.

Suffix:

<Chn> Channel number used to identify the active trace

Parameters:

<CenterTime> Center time of the time gate
 Range: -99.8999999 s to +99.8999999 s
 Increment: 0.1 ns
 *RST: 1.5E-009 s
 Default unit: s

Example:

```
*RST; :CALC:TRAN:TIME:STAT ON; :CALC:FILT:TIME:STAT ON
```

Reset the instrument and enable the time domain representation and the time gate.

```
CALC:FILT:TIME:CENT 0; SPAN 5ns
```

Set the center time to 0 ns and the time span to 5 ns.

Manual operation: See ["Axis Pair"](#) on page 285

CALCulate<Chn>:FILTer[:GATE]:TIME:DCHebshev <SidebandSup>

Sets the sideband suppression for the Dolph-Chebyshev time gate. The command is only available if a Dolph-Chebyshev time gate is active ([CALCulate<Chn>:FILTer\[:GATE\]:TIME:WINDow DCHebshev](#)).

Suffix:

<Chn> Channel number used to identify the active trace

Parameters:

<SidebandSup> Sideband suppression
 Range: 10 dB to 120 dB
 Increment: 10 dB
 *RST: 32 dB
 Default unit: dB

Example:

```
*RST; :CALC:FILT:TIME:WIND DCH
```

Reset the instrument and select a Dolph-Chebyshev time gate for filtering the data in the frequency domain.

```
CALC:FILT:TIME:DCH 25
```

Set the sideband suppression to 25 dB.

Manual operation: See ["Side Lobe Level"](#) on page 285

CALCulate<Chn>:FILTer[:GATE]:TIME:SHAPE <TimeGate>

Selects the time gate to be applied to the time domain transform.

Tip:

Use the generalized command [CALCulate<Chn>:FILTer\[:GATE\]:TIME:WINDow](#) if you wish to select a Dolph-Chebyshev time gate.

Suffix:

<Chn> Channel number used to identify the active trace

Parameters:

<TimeGate> MAXimum | WIDE | NORMal | MINimum
 MINimum - Steepest edges (rectangle)
 WIDE - Normal gate (Hann)
 NORM - Steep edges (Hamming)
 Maximum - Maximum flatness (Bohman)
 *RST: WIDE

Example:

*RST; :CALC:FILT:TIME:SHAP?

Reset the instrument and query the type of time gate used. The response is WIDE.

Manual operation: See ["Shape"](#) on page 285

CALCulate<Chn>:FILTer[:GATE]:TIME:SHOW <Boolean>

Enables or disables permanent display of the gate limits.

Suffix:

<Chn> Channel number used to identify the active trace

Parameters:

<Boolean> ON - time gate permanently displayed
 OFF - time gate hidden
 *RST: OFF

Example:

See [CALCulate<Chn>:FILTer\[:GATE\]:TIME:CENTer](#)

Manual operation: See ["Show Range Lines"](#) on page 285

**CALCulate<Chn>:FILTer[:GATE]:TIME:SPAN **

Defines the span of the time gate.

Suffix:

<Chn> Channel number used to identify the active trace

Parameters:

 Span of the time gate.
 Range: 2E-012 s to 200 s
 Increment: 0.1 ns
 *RST: 5E-009 s
 Default unit: s

Example:

See [CALCulate<Chn>:FILTer\[:GATE\]:TIME:CENTer](#)

Manual operation: See ["Gate Span"](#) on page 281

CALCulate<Chn>:FILTer[:GATE]:TIME:STARt <StartTime>

CALCulate<Chn>:FILTer[:GATE]:TIME:STOP <StopTime>

These commands define the start and stop times of the time gate, respectively.

Suffix:

<Chn> Channel number used to identify the active trace

Parameters:

<StopTime> Start or stop time of the time gate.
 Range: -100 s to +99.99999999998 s (start time) and
 -99.99999999998 s to +100 s (stop time)
 Increment: 0.1 ns
 *RST: -1E-009 s (start time) to +4E-009 s (stop time)
 Default unit: s

Example:

```
*RST; :CALC:TRAN:TIME:STAT ON; :CALC:FILT:TIME:
STAT ON
```

Reset the instrument and enable the time domain representation and the time gate.

```
CALC:FILT:TIME:STAR 0; STOP 10ns; SHOW ON
```

Set the start time to 0 ns and the stop time to 10 ns and display the time gate permanently.

Manual operation: See "Axis Pair" on page 285

Note: If the start frequency entered is greater than the current stop frequency, the stop frequency is set to the start frequency plus the minimum frequency span (`CALCulate<Chn>:FILTer[:GATE]:TIME:SPAN`).

If the stop frequency entered is smaller than the current start frequency, the start frequency is set to the stop frequency minus the minimum frequency span.

CALCulate<Chn>:FILTer[:GATE]:TIME:STATe <Boolean>

Determines whether the time gate for trace no. <Chn> is enabled.

Suffix:

<Chn> Channel number used to identify the active trace

Parameters:

<Boolean> ON - time gate enabled
 OFF - time gate disabled
 *RST: OFF

Example:

```
*RST; :CALC:TRAN:TIME:STAT?
CALC:FILT:TIME:STAT?
```

Reset the instrument, activating a frequency sweep, and query whether the default trace is displayed in the time domain and whether the time gate is enabled. The response to both queries is 0.

Manual operation: See "Time Gate" on page 284

CALCulate<Chn>:FILTer[:GATE]:TIME:WINDow <TimeGate>

Selects the time gate to be applied to the time domain transform.

Suffix:

<Chn> Channel number used to identify the active trace

Parameters:

<TimeGate> RECT | HAMMing | HANNing | BOHMan | DCHebyshev
 RECT - steepest edges (rectangle)
 HANN - normal gate (Hann)
 HAMMing - steep edges (Hamming)
 BOHMan - minimum flatness (Bohman)
 DCHebyshev - arbitrary gate shape (Dolph-Chebyshev)
 *RST: HANN

Example: See `CALCulate<Chn>:FILTer[:GATE]:TIME:DCHebyshev`

Manual operation: See "Shape" on page 285

8.3.1.6 CALCulate:FMODEl...

The `CALCulate:FMODEl...` commands are related to "fixture modeling" tools (see [Chapter 5.6.2.9, "Fixture Modeling and Deembedding"](#), on page 187).



In the current implementation the firmware assumes that balanced fixture modeling and dembedding is required, whenever a balanced port is configured.

A mixture of single-ended and balanced fixture modeling is not supported.

CALCulate:FMODEl:ISD...

Commands for AtaiTec's *In Situ De-Embedding* (ISD) tool, see <http://ataitec.com/products/isd/>

<code>CALCulate:FMODEl:ISD<Ph_pt>:ATTenuation:BEHavior</code>	616
<code>CALCulate:FMODEl:ISD<Ph_pt>:COUPon:MEASure</code>	616
<code>CALCulate:FMODEl:ISD<Ph_pt>:COUPon:MEASure:FILEname</code>	617
<code>CALCulate:FMODEl:ISD<Ph_pt>:COUPon:MEASure:OPEN</code>	617
<code>CALCulate:FMODEl:ISD<Ph_pt>:COUPon:MEASure:OPEN:FILEname</code>	617
<code>CALCulate:FMODEl:ISD<Ph_pt>:COUPon:MEASure:SHORT</code>	617
<code>CALCulate:FMODEl:ISD<Ph_pt>:COUPon:MEASure:SHORT:FILEname</code>	618
<code>CALCulate:FMODEl:ISD<Ph_pt>:COUPon:TYPE</code>	618
<code>CALCulate:FMODEl:ISD<Ph_pt>:COUPon[:STATe]</code>	618
<code>CALCulate:FMODEl:ISD<Ph_pt>:DCExtrapolat</code>	619
<code>CALCulate:FMODEl:ISD<Ph_pt>:DUT:MEASure</code>	619
<code>CALCulate:FMODEl:ISD<Ph_pt>:DUT:MEASure:FILEname</code>	619
<code>CALCulate:FMODEl:ISD<Ph_pt>:SMALIfixture</code>	619
<code>CALCulate:FMODEl:ISD<Ph_pt>:SMALIfixture</code>	620
<code>CALCulate:FMODEl:ISD<Ph_pt>:DUT:TYPE</code>	620
<code>CALCulate:FMODEl:ISD<Ph_pt>:DUT[:STATe]</code>	620
<code>CALCulate:FMODEl:ISD<Ph_pt>:FTIME:DUT</code>	620

CALCulate:FMODEl:ISD<Ph_pt>:FTIME:OVERride.....	621
CALCulate:FMODEl:ISD<Ph_pt>:OPERation.....	621
CALCulate:FMODEl:ISD<Ph_pt>:PASSivity.....	621
CALCulate:FMODEl:ISD<Ph_pt>:PORT:ORDER.....	622
CALCulate:FMODEl:ISD<Ph_pt>:PORT:SKIP.....	622
CALCulate:FMODEl:ISD<Ph_pt>:PORT:SKIP:LEFT.....	622
CALCulate:FMODEl:ISD<Ph_pt>:PORT:SKIP:NONE.....	622
CALCulate:FMODEl:ISD<Ph_pt>:PORT:SKIP:RIGHT.....	622
CALCulate:FMODEl:ISD<Ph_pt>:RUN:RUN.....	623
CALCulate:FMODEl:ISD<Ph_pt>:RUN[:STATE].....	623
CALCulate:FMODEl:ISD<Ph_pt>:SCALE:ATTenuation.....	623
CALCulate:FMODEl:ISD<Ph_pt>:SCALE:FREQuency.....	624
CALCulate:FMODEl:ISD<Ph_pt>:SCALE:FTIME.....	624
CALCulate:FMODEl:ISD<Ph_pt>:TRACe:COUPling.....	624

CALCulate:FMODEl:ISD<Ph_pt>:ATTenuation:BEHavior <AttenuationBehavior>

Sets/gets the `linear_2x` batch mode parameter of the ISD tool:

- LINear (parameter value 1): Used for linear insertion loss of test coupon
- NONLinear (2): Used for non-linear insertion loss of test coupon
- RESonant (3): The 2x thru test coupon will be split and used directly for deembedding.
This option may be more accurate when the fixture and 2x Thru have the same impedance at every location

Suffix:

<Ph_pt> This suffix is ignored.

Parameters:

<AttenuationBehavior>RESonant | LINear | NONLinear

Manual operation: See "[Test Coupons > Insertion Loss](#)" on page 462

CALCulate:FMODEl:ISD<Ph_pt>:COUPon:MEASure

For a fixture modeling with the ISD tool and coupon types SYMMetric2x | OPEN1x | SHORT1x (see `CALCulate:FMODEl:ISD<Ph_pt>:COUPon:TYPE`), this command starts the measurement of the coupon at the active ports (see `CALCulate:FMODEl:ISD<Ph_pt>:COUPon[:STATE]`).

Suffix:

<Ph_pt> This suffix is ignored.

Example:

See [Chapter 9.2.6, "Fixture Modeling"](#), on page 1141

Usage:

Event

Manual operation: See "[Measure / Measure Open / Measure Short](#)" on page 457

CALCulate:FMODEl:ISD<Ph_pt>:COUPon:MEASure:FILEname <String>

For a fixture modeling with the ISD tool and coupon types SYMMetric2x | OPEN1x | SHORt1x (see [CALCulate:FMODEl:ISD<Ph_pt>:COUPon:TYPE](#)), this command loads the coupon properties from a Touchstone file.

Suffix:

<Ph_pt> This suffix is ignored.

Parameters:

<String> Path to the Touchstone file, either absolute or relative to the current directory (see [MMEMemory:CDIRectory](#))

Manual operation: See "[Load File / 1x Open Preset / 1x Short Preset](#)" on page 458

CALCulate:FMODEl:ISD<Ph_pt>:COUPon:MEASure:OPEN

For a fixture modeling with the ISD tool and coupon type OPSHort1x (see [CALCulate:FMODEl:ISD<Ph_pt>:COUPon:TYPE](#)), this command starts the measurement of the **Open** coupon at the active ports (see [CALCulate:FMODEl:ISD<Ph_pt>:COUPon\[:STATe\]](#)).

Suffix:

<Ph_pt> This suffix is ignored.

Usage:

Event

Manual operation: See "[Measure / Measure Open / Measure Short](#)" on page 457

CALCulate:FMODEl:ISD<Ph_pt>:COUPon:MEASure:OPEN:FILEname <String>

For a fixture modeling with the ISD tool and coupon type OPSHort1x (see [CALCulate:FMODEl:ISD<Ph_pt>:COUPon:TYPE](#)), this command loads the properties of the Open coupon from a Touchstone file.

Suffix:

<Ph_pt> This suffix is ignored.

Parameters:

<String> Path to the Touchstone file, either absolute or relative to the current directory (see [MMEMemory:CDIRectory](#))

Manual operation: See "[Load File / 1x Open Preset / 1x Short Preset](#)" on page 458

CALCulate:FMODEl:ISD<Ph_pt>:COUPon:MEASure:SHORT

For a fixture modeling with the ISD tool and coupon type OPSHort1x (see [CALCulate:FMODEl:ISD<Ph_pt>:COUPon:TYPE](#)), this command starts the measurement of the **Short** coupon at the active ports (see [CALCulate:FMODEl:ISD<Ph_pt>:COUPon\[:STATe\]](#)).

Suffix:

<Ph_pt> This suffix is ignored.

Usage: Event

Manual operation: See ["Measure / Measure Open / Measure Short"](#) on page 457

CALCulate:FMODEl:ISD<Ph_pt>:COUPon:MEASure:SHORT:FILEname <String>

For a fixture modeling with the ISD tool and coupon type OPShort1x (see [CALCulate:FMODEl:ISD<Ph_pt>:COUPon:TYPE](#)), this command loads the properties of the Short coupon from a Touchstone file.

Suffix:

<Ph_pt> This suffix is ignored.

Parameters:

<String> Path to the Touchstone file, either absolute or relative to the current directory (see [MMEMory:CDIRectory](#))

Manual operation: See ["Load File / 1x Open Preset / 1x Short Preset"](#) on page 458

CALCulate:FMODEl:ISD<Ph_pt>:COUPon:TYPE <CouponType>

Sets/gets the coupon type to be measured for a fixture modeling with the ISD tool.

Suffix:

<Ph_pt> This suffix is ignored.

Parameters:

<CouponType> SYMMetric2x | OPEN1x | SHORT1x | OPShort1x

Example: See [Chapter 9.2.6, "Fixture Modeling"](#), on page 1141

Manual operation: See ["Coupon Type"](#) on page 457

CALCulate:FMODEl:ISD<Ph_pt>:COUPon[:STATe] <Boolean>

For a fixture modeling with the ISD tool, this command allows to specify the ports to which the test coupon is connected.

This has to be defined before measuring the test coupon (using [CALCulate:FMODEl:ISD<Ph_pt>:COUPon:MEASure](#) or [CALCulate:FMODEl:ISD<Ph_pt>:COUPon:MEASure:OPEN](#) and [CALCulate:FMODEl:ISD<Ph_pt>:COUPon:MEASure:SHORT](#)).

Suffix:

<Ph_pt> Physical port number

Parameters:

<Boolean> 1 (ON, true) if the test coupon is connected to port <Ph_pt>, 0 (OFF, false) otherwise

Example: See [Chapter 9.2.6, "Fixture Modeling"](#), on page 1141

Manual operation: See ["Active"](#) on page 458

CALCulate:FMODEl:ISD<Ph_pt>:DCEXtrapolat <Boolean>

Defines whether the de-/embedding file generated by the ISD tool contains (extrapolated) DC data.

Can only be set to ON, if a recent version of the ISD tool (from 2019-12 or later) is used. ON corresponds to `add_dc=1` in the tool's batch mode.

Suffix:

<Ph_pt> This suffix is ignored.

Parameters:

<Boolean>

OFF (0)

No DC data added, i.e. the touchstone data reach down to the start frequency of the instrument sweep.

ON (1)

The ISD tool adds (extrapolated) S-parameter data for $f = 0$.

*RST: OFF (0)

Manual operation: See "[DC Extrapolation](#)" on page 465

CALCulate:FMODEl:ISD<Ph_pt>:DUT:MEASure

For a fixture modeling with the ISD tool, this command allows to measure DUT + Fixture at the active ports (see [CALCulate:FMODEl:ISD<Ph_pt>:DUT\[:STATe\]](#))

Suffix:

<Ph_pt> This suffix is ignored.

Example:

See [Chapter 9.2.6, "Fixture Modeling"](#), on page 1141

Usage:

Event

Manual operation: See "[Measure](#)" on page 459

CALCulate:FMODEl:ISD<Ph_pt>:DUT:MEASure:FILEname <String>**Suffix:**

<Ph_pt>

Parameters:

<String>

Manual operation: See "[Load File](#)" on page 459

CALCulate:FMODEl:ISD<Ph_pt>:SMALIfixture <Boolean>

Enables/disables the ISD tool's small fixture mode.

Parameters:

<Boolean>

Manual operation: See "[Small Fixture](#)" on page 465

CALCulate:FMODEl:ISD<Ph_pt>:SMALIfixture <Boolean>

Enables/disables the ISD tool's small fixture mode.

Parameters:

<Boolean>

Manual operation: See ["Small Fixture"](#) on page 465

CALCulate:FMODEl:ISD<Ph_pt>:DUT:TYPE <DUTType>

Defines whether the DUT is active or passive.

Corresponds to the `active_dut` batch mode parameter of the ISD tool.

Suffix:

<Ph_pt> This suffix is ignored.

Parameters:

<DUTType> PASSive | ACTive

Manual operation: See ["DUT Type"](#) on page 463

CALCulate:FMODEl:ISD<Ph_pt>:DUT[:STATe] <Boolean>

For a fixture modeling with the ISD tool, this command allows to specify the ports to which the test fixture is connected.

This has to be defined before measuring DUT + Fixture (using `CALCulate:FMODEl:ISD<Ph_pt>:DUT:MEASure`).

Suffix:

<Ph_pt> Physical port number

Parameters:

<Boolean> 1 (ON, true) if the test fixture is connected to port <Ph_pt>, 0 (OFF, false) otherwise

Example: See [Chapter 9.2.6, "Fixture Modeling"](#), on page 1141

Manual operation: See ["Active"](#) on page 459

CALCulate:FMODEl:ISD<Ph_pt>:FTIME:DUT <FltDutAndLeadIns>

If `CALCulate:FMODEl:ISD<Ph_pt>:FTIME:OVERride` is set to TRUE, this command allows to set the flight time for DUT + Lead-ins manually.

This is equivalent to setting the `leadin_dut_time` batch mode parameter of the ISD tool to a numeric value (not `auto`).

Suffix:

<Ph_pt> This suffix is ignored.

Parameters:

<FltDutAndLeadIns> Default unit: s

Manual operation: See ["Flt Tm for DUT + Lead Ins"](#) on page 463

CALCulate:FMODEl:ISD<Ph_pt>:FTIME:OVERride <Boolean>

If set to true, the flight time for DUT + lead-in is specified using `CALCulate:FMODEl:ISD<Ph_pt>:FTIME:DUT`. Otherwise, it is calculated automatically.

True is equivalent to setting the `leadin_dut_time` batch mode parameter of the ISD tool to `auto`.

Suffix:

<Ph_pt> This suffix is ignored.

Parameters:

<Boolean>

Manual operation: See ["Automatic Flt Tm for DUT + Lead Ins"](#) on page 463

CALCulate:FMODEl:ISD<Ph_pt>:OPERation <Operation>

Defines the execution mode of the ISD tool.

Suffix:

<Ph_pt> This suffix is ignored.

Parameters:

<Operation>

FAST | ACCurate

ACCurate: normal execution mode

FAST: reduces the execution time to ~50%

In many cases the FAST mode can be enabled with only little loss of accuracy.

Manual operation: See ["Operation \(fast/acc\)"](#) on page 464

CALCulate:FMODEl:ISD<Ph_pt>:PASSivity <Boolean>

Defines whether the ISD tool shall enforce passivity and reciprocity for the test coupons and the test fixture.

Corresponds to the `passive` batch mode parameter of the ISD tool.

Suffix:

<Ph_pt> This suffix is ignored.

Parameters:

<Boolean>

ON (0): enforce passivity and reciprocity

OFF (0): do not enforce passivity and reciprocity

Manual operation: See ["Enforce Passitivity"](#) on page 464

CALCulate:FMODEl:ISD<Ph_pt>:PORT:ORDER <PortOrder>

Defines how the ISD tool shall interpret the DUT + Fixture data (see [CALCulate:FMODEl:ISD<Ph_pt>:DUT:MEASure](#)):

- **NON:** ports 1 to N are on the left and ports N+1 to 2*N are on the right
- **ODD:** ports 1, 3, 5, etc. are on the left and ports 2, 4, 6, etc. are on the right.
- **ALL:** use this to tell the ISD tool that all ports are on the left (i.e. assumed to be coupled)

Corresponds to the `port_order` batch mode parameter of the ISD tool.

Suffix:

<Ph_pt> This suffix is ignored.

Parameters:

<PortOrder> ODD | NON | ALL

Manual operation: See "[Port Sequence](#)" on page 463

CALCulate:FMODEl:ISD<Ph_pt>:PORT:SKIP <String>

Tells the ISD tool which ports (in the measured DUT + Test Fixture file) shall be skip-ped when the tool is run.

Equivalent to using the `ports_to_skip` batch mode parameter of the ISD tool with a list of (positive) port numbers.

Suffix:

<Ph_pt> This suffix is ignored.

Parameters:

<String> The port numbers, separated by blanks (e.g. '1 3 4').

Manual operation: See "[Ports to Skip \(manual\)](#)" on page 464

CALCulate:FMODEl:ISD<Ph_pt>:PORT:SKIP:LEFT**CALCulate:FMODEl:ISD<Ph_pt>:PORT:SKIP:NONE****CALCulate:FMODEl:ISD<Ph_pt>:PORT:SKIP:RIGHT**

Tells the ISD tool which ports (in the measured DUT + Test Fixture file) shall be skip-ped when the tool is run.

- **...:LEFT:** skip the ports on the left (according to the port order specified using [CALCulate:FMODEl:ISD<Ph_pt>:PORT:ORDER](#))
- **...:NONE:** do not skip any ports
- **...:RIGHT:** skip the ports on the right (according to the port order specified using [CALCulate:FMODEl:ISD<Ph_pt>:PORT:ORDER](#))

Equivalent to setting the `ports_to_skip` batch mode parameter of the ISD tool to -1, 0 or -2, respectively.

Use [CALCulate:FMODEl:ISD<Ph_pt>:PORT:SKIP](#) to define an arbitrary set of ports to be skipped.

Suffix:
<Ph_pt> This suffix is ignored.

Usage: Event

Manual operation: See "Ports to Skip" on page 463

CALCulate:FMODEl:ISD<Ph_pt>:RUN:RUN

Runs the ISD tool.

Before executing this command, make sure that

- the test coupon measurement (using `CALCulate:FMODEl:ISD<Ph_pt>:COUPon:MEASure:OPEN` and `CALCulate:FMODEl:ISD<Ph_pt>:COUPon:MEASure:SHORT` for 1xOpen+1xShort, `CALCulate:FMODEl:ISD<Ph_pt>:COUPon:MEASure` otherwise) finished successfully, or the test coupon data were successfully loaded from file (using `CALCulate:FMODEl:ISD<Ph_pt>:COUPon:MEASure:FILENAME`)
- the measurement of DUT + test fixture (using `CALCulate:FMODEl:ISD<Ph_pt>:DUT:MEASure`) finished successfully

The resulting Touchstone files are written to C:\Users\Public\Documents\Rohde-Schwarz\Vna\Embedding. If result files with the same name already exist, they will be overwritten.

Suffix:
<Ph_pt> This suffix is ignored.

Example: See [Chapter 9.2.6, "Fixture Modeling"](#), on page 1141

Usage: Event

Manual operation: See "Run <Fixture Modeling Tool>" on page 460

CALCulate:FMODEl:ISD<Ph_pt>:RUN[:STATe] <Boolean>

For a fixture modeling with the ISD tool, this command allows to specify the ports to which the deembedding files shall be assigned after the tool has run.

Suffix:
<Ph_pt> Physical port number for single-ended deembedding, logical port number for balanced deembedding.

Parameters:
<Boolean> 1 (ON) if a deembedding file shall be assigned to port <Pt>, 0 (OFF) otherwise

Example: See [Chapter 9.2.6, "Fixture Modeling"](#), on page 1141

Manual operation: See "Apply" on page 460

CALCulate:FMODEl:ISD<Ph_pt>:SCALE:ATTenuation <AttenLeadInScaling>

Scales the test coupon's attenuation (dB).

Sets/gets the `atten_scale 1` batch mode parameter of the ISD tool

Suffix:

<Ph_pt> This suffix is ignored.

Parameters:

<AttenLeadInScaling>

Manual operation: See ["Scaling for Lead In Atten"](#) on page 462

CALCulate:FMODEl:ISD<Ph_pt>:SCALE:FREQuency <MaxFrequency>

Defines the maximum frequency to deembed.

Corresponds to the `max_frequency` batch mode parameter of the ISD tool.

Suffix:

<Ph_pt> This suffix is ignored.

Parameters:

<MaxFrequency> Default unit: Hz

Manual operation: See ["Max Freq to Deembed"](#) on page 464

CALCulate:FMODEl:ISD<Ph_pt>:SCALE:FTIME <FltLeadInScalingTime>

Overrides the lead-in's flight time in case the through-trace test coupon is a bit too short or too long.

Sets/gets the `atten_scale 1` batch mode parameter of the ISD tool.

Suffix:

<Ph_pt> This suffix is ignored.

Parameters:

<FltLeadInScalingTime>

Manual operation: See ["Scaling for Flt Tm"](#) on page 462

CALCulate:FMODEl:ISD<Ph_pt>:TRACe:COUPling <TraceCoupling>

Tells the ISD tool about coupling among lead-in traces.

Corresponds to the `coupling` batch mode parameter of the ISD tool.

Suffix:

<Ph_pt> This suffix is ignored.

Parameters:

<TraceCoupling> NONE | WEAK | STRong
 NONE: no coupling.
 WEAK: coupling will be extracted even if there are 2 ports enabled on the test coupon
 STRong: if the test coupon is a 4-port file, and there are two ports to be extracted, the ISD tool will optimize odd- and even-mode insertion losses

Manual operation: See "Trace Coupling" on page 464

CALCulate:FMODEl:SFD...

Commands for PacketMicro's *Smart Fixture De-embedding* (SFD), see <https://www.packetmicro.com/Products/sfd-tool.html>

CALCulate:FMODEl:SFD<Ph_pt>:AUTO.....	625
CALCulate:FMODEl:SFD<Ph_pt>:COUPon:MEASure.....	625
CALCulate:FMODEl:SFD<Ph_pt>:COUPon:MEASure:FILEname.....	626
CALCulate:FMODEl:SFD<Ph_pt>:COUPon:TYPE.....	626
CALCulate:FMODEl:SFD<Ph_pt>:COUPon[:STATe].....	626
CALCulate:FMODEl:SFD<Ph_pt>:DIFFcfg.....	626
CALCulate:FMODEl:SFD<Ph_pt>:DUT:MEASure.....	627
CALCulate:FMODEl:SFD<Ph_pt>:DUT:MEASure:FILEname.....	627
CALCulate:FMODEl:SFD<Ph_pt>:DUT[:STATe].....	627
CALCulate:FMODEl:SFD<Ph_pt>:RUN:RUN.....	627
CALCulate:FMODEl:SFD<Ph_pt>:RUN[:STATe].....	628
CALCulate:FMODEl:SFD<Ph_pt>:TOTaldiffcfg.....	628

CALCulate:FMODEl:SFD<Ph_pt>:AUTO <Boolean>

Defines whether the SFD tool shall perform automatic impedance adjustments.

Suffix:

<Ph_pt> This suffix is ignored.

Parameters:

<Boolean>

Manual operation: See "Adjust Impedance Mismatch" on page 466

CALCulate:FMODEl:SFD<Ph_pt>:COUPon:MEASure

For a fixture modeling with the SFD tool, this command starts the measurement of the coupon at the active ports (see `CALCulate:FMODEl:SFD<Ph_pt>:COUPon[:STATe]`).

The coupon type can be selected using `CALCulate:FMODEl:SFD<Ph_pt>:COUPon:TYPE`.

Suffix:

<Ph_pt> This suffix is ignored.

Usage: Event

Manual operation: See "[Measure / Measure Open / Measure Short](#)" on page 457

CALCulate:FMODEl:SFD<Ph_pt>:COUPon:MEASure:FILEname <String>

For a fixture modeling with the SFD tool, this command loads the coupon properties from a Touchstone file.

The coupon type can be selected using [CALCulate:FMODEl:SFD<Ph_pt>:COUPon:TYPE](#).

Suffix:
<Ph_pt> This suffix is ignored.

Parameters:
<String> Path to the Touchstone file, either absolute or relative to the current directory (see [MMEMory:CDIRECTory](#))

Manual operation: See "[Load File / 1x Open Preset / 1x Short Preset](#)" on page 458

CALCulate:FMODEl:SFD<Ph_pt>:COUPon:TYPE <CouponType>

Sets/gets the coupon type to be measured for a fixture modelling with the SFD tool.

Suffix:
<Ph_pt> This suffix is ignored.

Parameters:
<CouponType> SYMMetric2x | OPEN1x | SHORt1x

Manual operation: See "[Coupon Type](#)" on page 457

CALCulate:FMODEl:SFD<Ph_pt>:COUPon[:STATe] <Boolean>

For a fixture modeling with the SFD tool, this command allows to specify the ports to which the test coupon is connected.

This has to be defined before measuring the test coupon (using [CALCulate:FMODEl:SFD<Ph_pt>:DUT:MEASure](#)).

Suffix:
<Ph_pt> Physical port number

Parameters:
<Boolean> 1 (ON, true) if the test coupon is connected to port <Ph_pt>, 0 (OFF, false) otherwise

Manual operation: See "[Active](#)" on page 458

CALCulate:FMODEl:SFD<Ph_pt>:DIFFCfg <SFDPortConfig>

Tells the SFD tool about the port ordering of the 2x Thru test coupon.

Suffix:
 <Ph_pt> This suffix is ignored.

Parameters:
 <SFDPortConfig> ODD | NON
 ODD: odd ports are on the left and even ports are on the right
 NON: ports 1 to N are on the left and ports N+1 to 2·N are on the right

Manual operation: See ["2x Thru Port Ordering"](#) on page 465

CALCulate:FMODEl:SFD<Ph_pt>:DUT:MEASure

For a fixture modeling with the ISD tool, this command allows to measure the DUT + Fixture at the active ports (see [CALCulate:FMODEl:SFD<Ph_pt>:DUT\[:STATe\]](#)).

Suffix:
 <Ph_pt> This suffix is ignored.

Usage: Event

Manual operation: See ["Measure"](#) on page 459

CALCulate:FMODEl:SFD<Ph_pt>:DUT:MEASure:FILEname <String>

Suffix:
 <Ph_pt>

Parameters:
 <String>

Manual operation: See ["Load File"](#) on page 459

CALCulate:FMODEl:SFD<Ph_pt>:DUT[:STATe] <Boolean>

For a fixture modeling with the SFD tool, this command allows to specify the ports to which the test fixture is connected.

This has to be defined before measuring DUT + Fixture (using [CALCulate:FMODEl:SFD<Ph_pt>:DUT:MEASure](#)).

Suffix:
 <Ph_pt> Physical port number

Parameters:
 <Boolean> 1 (ON, true) if the test fixture is connected to port <Ph_pt>, 0 (OFF, false) otherwise

Manual operation: See ["Active"](#) on page 459

CALCulate:FMODEl:SFD<Ph_pt>:RUN:RUN

Runs the SFD tool.

Before executing this command, make sure that:

- The test coupon measurement (using `CALCulate:FMODEl:SFD<Ph_pt>:COUPon:MEASure`) finished successfully, or the test coupon data were successfully loaded from file (using `CALCulate:FMODEl:SFD<Ph_pt>:COUPon:MEASure:FILEname`)
- The measurement of DUT + test fixture (using `CALCulate:FMODEl:SFD<Ph_pt>:DUT:MEASure`) finished successfully.

The resulting Touchstone files are written to C:\Users\Public\Documents\Rohde-Schwarz\Vna\Embedding. If result files with the same name already exist, they are overwritten.

Suffix:

<Ph_pt> This suffix is ignored

Usage: Event

Manual operation: See "[Run <Fixture Modeling Tool>](#)" on page 460

CALCulate:FMODEl:SFD<Ph_pt>:RUN[:STATe] <Boolean>

For a fixture modeling with the SFD tool, this command allows to specify the ports to which the deembedding files shall be assigned after the tool has run.

Suffix:

<Ph_pt> Physical port number for single-ended deembedding, logical port number for balanced deembedding.

Parameters:

<Boolean> 1 (ON) if a deembedding file shall be assigned to port <Pt>, 0 (OFF) otherwise

Manual operation: See "[Apply](#)" on page 460

CALCulate:FMODEl:SFD<Ph_pt>:TOTAlDIFFcFg <SFDPortConfig>

Tells the SFD tool about the port ordering of the Test Fixture.

Suffix:

<Ph_pt> This suffix is ignored.

Parameters:

<SFDPortConfig> ODD | NON
 ODD: odd ports are on the left and even ports are on the right
 NON: ports 1 to N are on the left and ports N+1 to 2·N are on the right

Manual operation: See "[Total Port Ordering](#)" on page 465

CALCulate:FMODEl:DELT...

Commands for *Delta-L* PCB characterization (see [Chapter 5.7.11, "Delta-L 4.0 PCB Characterization"](#), on page 204).

CALCulate:FMODEl:DELT<Ph_pt>:FREQUencies:CURRent?	629
CALCulate:FMODEl:DELT<Ph_pt>:FREQUencies:CURRent:COUNT?	630
CALCulate:FMODEl:DELT<Ph_pt>:FREQUencies:DEFault?	630
CALCulate:FMODEl:DELT<Ph_pt>:FREQUencies:DEFault:COUNT?	630
CALCulate:FMODEl:DELT<Ph_pt>:FREQUencies:USEDefault	631
CALCulate:FMODEl:DELT<Ph_pt>:FREQUencies:USER?	631
CALCulate:FMODEl:DELT<Ph_pt>:FREQUencies:USER:COUNT?	631
CALCulate:FMODEl:DELT<Ph_pt>:FREQUencies:USER:ADD	632
CALCulate:FMODEl:DELT<Ph_pt>:FREQUencies:USER:DELeTe	632
CALCulate:FMODEl:DELT<Ph_pt>:FREQUencies:USER:DELeTe:ALL	632
CALCulate:FMODEl:DELT<Ph_pt>:M1L:CACHe:CLEAr:ALL	632
CALCulate:FMODEl:DELT<Ph_pt>:M1L:CACHe:CLEAr:SELeCted	633
CALCulate:FMODEl:DELT<Ph_pt>:M1L:FILeName	633
CALCulate:FMODEl:DELT<Ph_pt>:M2L:FILeName	633
CALCulate:FMODEl:DELT<Ph_pt>:M3L:FILeName	633
CALCulate:FMODEl:DELT<Ph_pt>:M1L:LENGth	633
CALCulate:FMODEl:DELT<Ph_pt>:M2L:LENGth	633
CALCulate:FMODEl:DELT<Ph_pt>:M3L:LENGth	633
CALCulate:FMODEl:DELT<Ph_pt>:M1L:MEASure	634
CALCulate:FMODEl:DELT<Ph_pt>:M2L:MEASure	634
CALCulate:FMODEl:DELT<Ph_pt>:M3L:MEASure	634
CALCulate:FMODEl:DELT<Ph_pt>:M1L[:STATe]	634
CALCulate:FMODEl:DELT<Ph_pt>:M2L[:STATe]	634
CALCulate:FMODEl:DELT<Ph_pt>:M3L[:STATe]	634
CALCulate:FMODEl:DELT:M1L:DIFFmode	635
CALCulate:FMODEl:DELT:MEASurement	635
CALCulate:FMODEl:DELT<Ph_pt>:METHod	635
CALCulate:FMODEl:DELT<Ph_pt>:PORDer	636
CALCulate:FMODEl:DELT<Ph_pt>:RUN	636
CALCulate:FMODEl:DELT<Ph_pt>:SWEep:CONTRol	636
CALCulate:FMODEl:DELT<Ph_pt>:SWEep:CONTRol:IFBW?	637
CALCulate:FMODEl:DELT<Ph_pt>:SWEep:CONTRol:STEP?	637
CALCulate:FMODEl:DELT<Ph_pt>:SWEep:FREQUency:MAXimum	637
CALCulate:FMODEl:DELT<Ph_pt>:SWEep:FREQUency:MINimum	637
CALCulate:FMODEl:DELT<Ph_pt>:TCONfig	638
CALCulate:FMODEl:DELT:TDR	638

CALCulate:FMODEl:DELT<Ph_pt>:FREQUencies:CURRent?

Returns the frequencies at which the Delta-L algorithm calculates the loss-per-inch uncertainties.

You can use the algorithms's default or custom frequencies (see [CALCulate:FMODEl:DELT<Ph_pt>:FREQUencies:USEDefault](#)).

Suffix:

<Ph_pt> This suffix is ignored

Usage: Query only
Options: R&S ZND-K231
Manual operation: See "[Frequencies](#)" on page 479

CALCulate:FMODEl:DELT<Ph_pt>:FREQuencies:CURRent:COUNT?

Returns at how many frequencies the Delta-L algorithm calculates the loss-per-inch uncertainties.

Use `CALCulate:FMODEl:DELT<Ph_pt>:FREQuencies:CURRent?` to query the list of frequencies.

Suffix:
<Ph_pt> This suffix is ignored
Usage: Query only
Options: R&S ZND-K231
Manual operation: See "[Frequencies](#)" on page 479

CALCulate:FMODEl:DELT<Ph_pt>:FREQuencies:DEFault?

Returns the frequencies at which the Delta-L algorithm calculates the loss-per-inch uncertainties per default.

You can either use the algorithms's default or custom frequencies (see `CALCulate:FMODEl:DELT<Ph_pt>:FREQuencies:USEDefault`).

Suffix:
<Ph_pt> This suffix is ignored
Usage: Query only
Options: R&S ZND-K231
Manual operation: See "[Frequencies](#)" on page 479

CALCulate:FMODEl:DELT<Ph_pt>:FREQuencies:DEFault:COUNT?

Returns the number of frequencies at which the Delta-L algorithm calculates the loss-per-inch uncertainties per default.

Use `CALCulate:FMODEl:DELT<Ph_pt>:FREQuencies:DEFault?` to query the frequencies.

Suffix:
<Ph_pt> This suffix is ignored
Usage: Query only
Options: R&S ZND-K231
Manual operation: See "[Frequencies](#)" on page 479

CALCulate:FMODEl:DELT<Ph_pt>:FREQuencies:USEDefault <Boolean>

Delta-L computes the uncertainty in the loss-per-inch calculation at specified frequencies.

This command specifies whether to use the tool's default frequencies or custom frequencies, which can be defined using `CALCulate:FMODEl:DELT<Ph_pt>:FREQuencies:USER` commands.

Suffix:

<Ph_pt> This suffix is ignored

Parameters:

<Boolean> **ON (1)**
Use default frequencies
OFF (0)
Use custom frequencies

Options: R&S ZND-K231

Manual operation: See "[Frequencies](#)" on page 479

CALCulate:FMODEl:DELT<Ph_pt>:FREQuencies:USER?

The Delta-L algorithm can calculate the loss-per-inch uncertainties either at default or at custom frequencies (see `CALCulate:FMODEl:DELT<Ph_pt>:FREQuencies:USEDefault`).

This command returns the custom frequencies, defined using `CALCulate:FMODEl:DELT<Ph_pt>:FREQuencies:USER:ADD` etc.

Suffix:

<Ph_pt> This suffix is ignored

Usage: Query only

Options: R&S ZND-K231

Manual operation: See "[Frequencies](#)" on page 479

CALCulate:FMODEl:DELT<Ph_pt>:FREQuencies:USER:COUNT?

The Delta-L algorithm can calculate the loss-per-inch uncertainties either at default or at custom frequencies (see `CALCulate:FMODEl:DELT<Ph_pt>:FREQuencies:USEDefault`).

This command returns the number of custom frequencies, defined using `CALCulate:FMODEl:DELT<Ph_pt>:FREQuencies:USER:ADD` etc.

Suffix:

<Ph_pt> This suffix is ignored

Usage: Query only

Options: R&S ZND-K231

Manual operation: See "Frequencies" on page 479

CALCulate:FMODEl:DELT<Ph_pt>:FREQuencies:USER:ADD <UserFrequencies>
CALCulate:FMODEl:DELT<Ph_pt>:FREQuencies:USER:DELeTe <Frequency>

The Delta-L algorithm can calculate the loss-per-inch uncertainties either at default or at custom frequencies (see [CALCulate:FMODEl:DELT<Ph_pt>:FREQuencies:USEDefault](#)).

`CALCulate:FMODEl:DELT<Ph_pt>:FREQuencies:USER:ADD|DELeTe` adds/deletes a frequency to/from the list of custom frequencies.

Suffix:

<Ph_pt> This suffix is ignored

Setting parameters:

<Frequency> Custom frequency
 Range: The frequency range of the analyzer
 Default unit: Hz

Usage: Setting only

Options: R&S ZND-K231

Manual operation: See "Frequencies" on page 479

CALCulate:FMODEl:DELT<Ph_pt>:FREQuencies:USER:DELeTe:ALL

The Delta-L algorithm can calculate the loss-per-inch uncertainties either at default or at custom frequencies (see [CALCulate:FMODEl:DELT<Ph_pt>:FREQuencies:USEDefault](#)).

This command clears the list of custom frequencies.

Suffix:

<Ph_pt> This suffix is ignored

Usage: Event

Options: R&S ZND-K231

Manual operation: See "Frequencies" on page 479

CALCulate:FMODEl:DELT<Ph_pt>:M1L:CAChE:CLEAr:ALL

If the 1-length method is used ([CALCulate:FMODEl:DELT<Ph_pt>:METHod M1L](#)), the VNA firmware builds up a cache of coupon measurements (Touchstone files) in the `Delta\1LMeasurementCache` subfolder of the user data folder `C:\Users\Public\Documents\Rohde-Schwarz\Vna`.

This command clears this cache.

Suffix:

<Ph_pt> This suffix is ignored

Usage: Event

Options: R&S ZND-K231

Manual operation: See "[Clear All 1L Measurements/Clear Selected 1L Measurements](#)" on page 482

CALCulate:FMODEl:DELT<Ph_pt>:M1L:CAChE:CLEAr:SELEcted <String>

If the 1-length method is used (`CALCulate:FMODEl:DELT<Ph_pt>:METHod M1L`), the VNA firmware builds up a cache of coupon measurements (Touchstone files) in the `DeltaL\1LMeasurementCache` subfolder of the user data folder

`C:\Users\Public\Documents\Rohde-Schwarz\Vna.`

This command deletes the selected file from this cache.

Suffix:
<Ph_pt> Physical port number

Setting parameters:
<String> Path to the Touchstone file, relative to the cache directory.

Usage: Setting only

Options: R&S ZND-K231

Manual operation: See "[Clear All 1L Measurements/Clear Selected 1L Measurements](#)" on page 482

CALCulate:FMODEl:DELT<Ph_pt>:M1L:FILEname <String>

CALCulate:FMODEl:DELT<Ph_pt>:M2L:FILEname <String>

CALCulate:FMODEl:DELT<Ph_pt>:M3L:FILEname <String>

Loads coupon measurement results for the 1st/2nd/3rd line from a `s2p` or `s4p` Touchstone file.

Suffix:
<Ph_pt> This suffix is ignored

Parameters:
<String> Path to the Touchstone file, either absolute or relative to the current directory (see `MMEMoRY:CDIRectory`).

Options: R&S ZND-K231

Manual operation: See "[Load File](#)" on page 481

CALCulate:FMODEl:DELT<Ph_pt>:M1L:LENGth <Length>

CALCulate:FMODEl:DELT<Ph_pt>:M2L:LENGth <Length>

CALCulate:FMODEl:DELT<Ph_pt>:M3L:LENGth <Length>

Specifies the length of the 1st/2nd/3rd line in Delta-L measurements (`CALCulate:FMODEl:DELT<Ph_pt>:M1L|M2L|M3L:MEASure`).

Suffix:
 <Ph_pt> This suffix is ignored

Parameters:
 <Length> Length in inches

Options: R&S ZND-K231

Manual operation: See "[Length](#)" on page 482

CALCulate:FMODEl:DELt<Ph_pt>:M1L:MEASure
CALCulate:FMODEl:DELt<Ph_pt>:M2L:MEASure
CALCulate:FMODEl:DELt<Ph_pt>:M3L:MEASure

Measures the full set of S-parameters at the active ports (see [CALCulate:FMODEl:DELt<Ph_pt>:M1L|M2L|M3L\[:STATe\]](#)).

Suffix:
 <Ph_pt> This suffix is ignored

Usage: Event

Options: R&S ZND-K231

Manual operation: See "[Measure](#)" on page 481

CALCulate:FMODEl:DELt<Ph_pt>:M1L[:STATe] <Boolean>
CALCulate:FMODEl:DELt<Ph_pt>:M2L[:STATe] <Boolean>
CALCulate:FMODEl:DELt<Ph_pt>:M3L[:STATe] <Boolean>

Defines the active ports for the 1st/2nd/3rd line Delta-L measurement ([CALCulate:FMODEl:DELt<Ph_pt>:M1L|M2L|M3L:MEASure](#)).

For each measurement, either two or four ports must be active. If the 1-length method is used ([CALCulate:FMODEl:DELt<Ph_pt>:METHod M1L](#)), then four ports must be active for the first line.

Suffix:
 <Ph_pt> Physical port number

Parameters:
 <Boolean> **ON (1)**
 Port <Ph_pt> is active in the respective measurement
OFF (0)
 Port <Ph_pt> is inactive in the respective measurement

Options: R&S ZND-K231

Manual operation: See "[Ports table](#)" on page 481

CALCulate:FMODEl:DELT:M1L:DIFFmode <Boolean>

The one-length method (`CALCulate:FMODEl:DELT<Ph_pt>:METHod M1L`) handles single-ended and balanced measurement results differently. This command selects between the two modes.

Parameters:

<Boolean> **OFF (0)**
Single-ended mode

ON (1)
Differential mode

*RST: OFF (0)

Options: R&S ZND-K231

Manual operation: See "[Method](#)" on page 478

CALCulate:FMODEl:DELT:MEASurement <Measurement>

Defines whether single-ended or balanced ports are measured for Delta-L characterizations.

Parameters:

<Measurement> SINGleended | BALanced

SINGleended
Single-ended ports only

BALanced
Balanced ports only

*RST: SINGleended

Options: R&S ZND-K231

Manual operation: See "[Measurements](#)" on page 479

CALCulate:FMODEl:DELT<Ph_pt>:METHod <Method>

Selects the Delta-L+ characterization method to be used.

Suffix:

<Ph_pt> This suffix is ignored.

Parameters:

<Method> M1L | M2L | M3L

 One, two, or three line/length analysis

Options: R&S ZND-K231

Manual operation: See "[Method](#)" on page 478

CALCulate:FMODEl:DELT<Ph_pt>:PORDer <PortOrder>

Declares how the DUT is connected to the measurement system. Choosing the wrong port ordering for your setup, can result in erroneous results.

Suffix:

<Ph_pt> This suffix is ignored

Parameters:

<PortOrder> ODDeven | SEQuential

ODDeven

Ports 1, 3 and 2, 4 form input/output pairs

SEQuential

Ports 1, 2 and 3, 4 form input/output pairs

Options:

R&S ZND-K231

Manual operation: See "[Port Order](#)" on page 479

CALCulate:FMODEl:DELT<Ph_pt>:RUN

Runs the AITT-DL tool with the collected measurement data and the configured Delta-L settings.

Suffix:

<Ph_pt> This suffix is ignored

Usage:

Event

Options:

R&S ZND-K231

Manual operation: See "[Run](#)" on page 482

CALCulate:FMODEl:DELT<Ph_pt>:SWEep:CONTRol <SweepControl>

Tells the firmware to use either default values for frequency step size and IF bandwidth, or the settings of the active channel for the Delta-L measurement.

The resulting frequency step size and IF bandwidth can be queried using [CALCulate:FMODEl:DELT<Ph_pt>:SWEep:CONTRol:STEP?](#) on page 637 and [CALCulate:FMODEl:DELT<Ph_pt>:SWEep:CONTRol:IFBW?](#) on page 637, respectively.

Suffix:

<Ph_pt> This suffix is ignored

Parameters:

<SweepControl> DEFault | CURRent

DEFault

Use the default values of the Delta-L algorithm:
10 MHz frequency step size, 1 kHz IF bandwidth

SweepControl

Use the values of the active channel

Options:

R&S ZND-K231

Manual operation: See "Sweep Control" on page 479

CALCulate:FMODEl:DELT<Ph_pt>:SWEep:CONTrol:IFBW?

For the Delta-L measurement, the firmware can either use a default IF bandwidth, or the active channel setting (see [CALCulate:FMODEl:DELT<Ph_pt>:SWEep:CONTrol](#)).

This query returns the resulting IF bandwidth.

Suffix:

<Ph_pt> This suffix is ignored

Usage: Query only

Options: R&S ZND-K231

Manual operation: See "Sweep Control" on page 479

CALCulate:FMODEl:DELT<Ph_pt>:SWEep:CONTrol:STEP?

For the Delta-L measurement, the firmware can either use a default frequency step size, or the active channel setting (see [CALCulate:FMODEl:DELT<Ph_pt>:SWEep:CONTrol](#)).

This query returns the resulting frequency step size.

Suffix:

<Ph_pt> This suffix is ignored

Usage: Query only

Options: R&S ZND-K231

Manual operation: See "Sweep Control" on page 479

CALCulate:FMODEl:DELT<Ph_pt>:SWEep:FREQuency:MAXimum <Frequency>

CALCulate:FMODEl:DELT<Ph_pt>:SWEep:FREQuency:MINimum <Frequency>

Defines the sweep range of the Delta-L measurement channel. The entered MAXimum and MINimum values are set as [\[SENSe<Ch>:\]FREQuency:STOP](#) and [\[SENSe<Ch>:\]FREQuency:START](#), respectively.

Furthermore, the VNA collects data for the LPI computation at the MAXimum and MINimum frequencies (in addition to [CALCulate:FMODEl:DELT<Ph_pt>:FREQuencies:CURRent?](#)).

Suffix:

<Ph_pt> This suffix is ignored

Parameters:

<Frequency>

Frequency values

The default MINimum frequency is the standard Delta-L start frequency of 10 MHz. The default MAXimum frequency is the instrument's maximum frequency.

Default unit: Hz

Options:

R&S ZND-K231

Manual operation: See "[Sweep Frequency](#)" on page 480**CALCulate:FMODEl:DELT<Ph_pt>:TCONfig <Boolean>**

Defines how the analyzer firmware sets up the diagram area for the Delta-L measurement.

Suffix:

<Ph_pt>

This suffix is ignored

Parameters:

<Boolean>

ON (1)

Use the recommended trace configuration, i.e. display each of the traces in a separate diagram.

OFF (0)

Display all traces in a single diagram.

Options:

R&S ZND-K231

Manual operation: See "[Trace](#)" on page 480**CALCulate:FMODEl:DELT:TDR <Boolean>**

If the [Time Domain Analysis](#) option R&S ZND-K2 is installed, this command allows you to add the TDR-based converted impedance traces to the recommended trace configuration.

Parameters:

<Boolean>

OFF (0)

TDR-based impedance traces added

ON (1)

TDR-based impedance traces not added

*RST: OFF

Options:

R&S ZND-K231

Manual operation: See "[Trace](#)" on page 480**CALCulate:FMODEl:EZD...**

Commands for *Eazy Deembedding* (see [Chapter 5.7.8, "Eazy De-embedding Based on IEEE 370"](#), on page 202).

CALCulate:FMODEl:EZD<Ph_pt>:COUPon:MEASure

For a fixture modeling with the Easy De-embedding (EZD) tool, this command starts the measurement of the symmetrical 2xThru coupon at the active ports (see [CALCulate:FMODEl:EZD<Ph_pt>:COUPon\[:STATe\]](#) on page 639).

Suffix:

<Ph_pt> This suffix is ignored.

Usage:

Event

Options:

R&S ZND-K210

Manual operation: See "[Measure / Measure Open / Measure Short](#)" on page 457

CALCulate:FMODEl:EZD<Ph_pt>:COUPon:MEASure:FILEname <String>

For a fixture modeling with the EZD tool, this command loads the coupon properties from a Touchstone file.

Suffix:

<Ph_pt> This suffix is ignored.

Parameters:

<String> Path to the Touchstone file, either absolute or relative to the current directory (see [MMEMory:CDIRectory](#))

Options:

R&S ZND-K210

Manual operation: See "[Load File / 1x Open Preset / 1x Short Preset](#)" on page 458

CALCulate:FMODEl:EZD<Ph_pt>:COUPon[:STATe] <Boolean>

For a fixture modeling with the EZD tool, this command allows to specify the ports to which the test coupon is connected.

This has to be defined before measuring the test coupon (using [CALCulate:FMODEl:EZD<Ph_pt>:COUPon:MEASure](#)).

Suffix:

<Ph_pt> Physical port number

Parameters:

<Boolean> **ON (1)**
if the test coupon is connected to port <Ph_pt>
OFF (0)
otherwise

Options:

R&S ZND-K210

Manual operation: See "[Active](#)" on page 458

CALCulate:FMODEl:EZD<Ph_pt>:DCEXtrapolat <Boolean>

Defines whether the Touchstone de-embedding file generated by the EZD tool contains data for DC.

Suffix:

<Ph_pt> This suffix is ignored.

Parameters:

<Boolean>

ON (1)

The EZD tool adds (extrapolated) S-parameter data for $f = 0$.

OFF (0)

The frequencies only reach down to the start frequency of the instrument sweep.

Options:

R&S ZND-K210

Manual operation: See "[DC Extrapolation](#)" on page 466

CALCulate:FMODEl:EZD<Ph_pt>:DUT:MEASure**Suffix:**

<Ph_pt>

Usage:

Event

Manual operation: See "[Measure](#)" on page 459

CALCulate:FMODEl:EZD<Ph_pt>:DUT:MEASure:FILEname <String>**Suffix:**

<Ph_pt>

Parameters:

<String>

Manual operation: See "[Load File](#)" on page 459

CALCulate:FMODEl:EZD<Ph_pt>:DUT[:STATe] <Boolean>**Suffix:**

<Ph_pt>

Parameters:

<Boolean>

Manual operation: See "[Active](#)" on page 459

CALCulate:FMODEl:EZD<Ph_pt>:GENerate:SIDE<1|2> <Boolean>

The EZD tool can create fixture deembedding data at side 1, at side 2, or at both sides.

Suffix:

<Ph_pt>

<1|2> Side

Parameters:

<Boolean>

ON (1)

Create fixture deembedding data at the specified side (<1|2>)

OFF (0)

Do not create fixture deembedding data at the specified side (<1|2>)

Options:

R&S ZND-K210

Manual operation: See ["Generate Side 1/Generate Side2"](#) on page 466**CALCulate:FModel:EZD<Ph_pt>:IMPedance** <Boolean>**Suffix:**

<Ph_pt>

Parameters:

<Boolean>

Manual operation: See ["Impedance Corrected/Impedance Correction Settings"](#) on page 466**CALCulate:FModel:EZD<Ph_pt>:IMPedance:BWIDlimit** <Value>**Suffix:**

<Ph_pt>

Parameters:

<Value> Default unit: Hz

Manual operation: See ["Impedance Corrected/Impedance Correction Settings"](#) on page 466**CALCulate:FModel:EZD<Ph_pt>:IMPedance:REFerence** <Value>**Suffix:**

<Ph_pt>

Parameters:

<Value> Default unit: Ohm

Manual operation: See ["Impedance Corrected/Impedance Correction Settings"](#) on page 466**CALCulate:FModel:EZD<Ph_pt>:RUN:RUN**

Runs the EZD tool.

Before executing this command, make sure that:

- The test coupon measurement (using `CALCulate:FMODEl:EZD<Ph_pt>:COUPon:MEASure`) finished successfully, or the test coupon data were successfully loaded from file (using `CALCulate:FMODEl:EZD<Ph_pt>:COUPon:MEASure:FILEname`)
- The measurement of DUT + test fixture (using `CALCulate:FMODEl:EZD<Ph_pt>:COUPon:MEASure`) finished successfully.

The resulting Touchstone files are written to C:\Users\Public\Documents\Rohde-Schwarz\Vna\Embedding. If result files with the same name already exist, they are overwritten.

Suffix:

<Ph_pt> This suffix is ignored

Usage: Event

Options: R&S ZND-K210

Manual operation: See "[Run <Fixture Modeling Tool>](#)" on page 460

CALCulate:FMODEl:EZD<Ph_pt>:RUN[:STATe] <Boolean>

For a fixture modeling with the EZD tool, this command allows to specify the ports to which the deembedding files shall be assigned after the tool has run.

Suffix:

<Ph_pt> Physical port number for single-ended deembedding, logical port number for balanced deembedding.

Parameters:

<Boolean> 1 (ON) , 0 (OFF) otherwise

ON (1)

if a deembedding file shall be assigned to port <Ph_pt>

OFF (0)

otherwise

Options: R&S ZND-K210

Manual operation: See "[Apply](#)" on page 460

More...

CALCulate:FMODEl:REName <Boolean>

If set to ON (1), the names of subsequently generated "Test Coupon" and "DUT + Test Fixture" files are prefixed with the current date and time.

Parameters:

<Boolean>

Manual operation: See "[Timestamp Filenames](#)" on page 456

8.3.1.7 CALCulate:FORMat...

The `CALCulate:FORMat...` commands determine the post-processing of the measured data in order to obtain various display formats.

CALCulate<Chn>:FORMat <Type>

Defines how the measured result at any sweep point is post-processed and presented in the graphical display.

Note: The analyzer allows arbitrary combinations of display formats and measured quantities; see [Chapter 6.3, "Format Softtool"](#), on page 252 and `CALCulate<Ch>:PARAmeter...` commands. Nevertheless, it is advisable to check which display formats are generally appropriate for an analysis of a particular measured quantity; see [Chapter 5.2.3.3, "Measured Quantities and Trace Formats"](#), on page 103.

Suffix:

<Chn> Channel number used to identify the active trace

Parameters:

<Type> MLINear | MLOGarithmic | PHASe | UPHase | POLar | SMITH | ISMith | GDELay | REAL | IMAGinary | SWR | COMPLex | MAGNitude | LOGarithmic

See list of parameters below.

*RST: MLOGarithmic

Example:

```
CALC4:PAR:SDEF 'Ch4Tr1', 'S11'
```

Create channel 4 and a trace named `Ch4Tr1` to measure the input reflection coefficient S_{11} . The trace becomes the active trace in channel 4.

```
CALC4:FORM MLIN; :DISP:WIND:TRAC2:FEED 'CH4TR1'
```

Calculate the magnitude of S_{11} and display it in a linearly scaled Cartesian diagram, assigning the trace number 2.

Manual operation: See ["dB Mag"](#) on page 253

Assume that the result at a sweep point is given by the complex quantity $z = x + jy$. Then the magnitude of z is calculated as

$$|z| = \sqrt{x^2 + y^2}$$

and in phase notation we have

$$z = |z| e^{j \text{Phase}(z)}, \text{ where } \text{Phase}(z) = \arctan(y/x).$$

The meaning of the parameters is as follows (see also table in [CALCulate<Chn>:MARKer<Mk>:FORMat](#) description):

MLINear	Displays $ z $ in a Cartesian diagram
MLOGarithmic MAGNitude (for compatibility with R&S ZVR analyzers)	Calculates $ z $ in dB ($= 20 \log z $) and displays it in a Cartesian diagram

PHASe	Calculates Phase(z) in the range between -180° and +180° and displays it in a Cartesian diagram
UPHase	Calculates Phase(z) (unwrapped) and displays it in a Cartesian diagram
POLar COMPLex (for compatibility with R&S ZVR analyzers)	Displays z in a polar diagram
SMITH	Displays z in a Smith diagram
ISMITH	Displays z in an inverted Smith diagram
GDELay	For frequency sweeps only Calculates the group delay at the related sweep point and displays it in a Cartesian diagram
REAL	Calculates $\text{Re}(z) = x$ and displays it in a Cartesian diagram
IMAGinary	Calculates $\text{Im}(z) = y$ and displays it in a Cartesian diagram
SWR	Calculates the standing wave ratio $(1 + z) / (1 - z)$ and displays it in a Cartesian diagram
LOGarithmic	Displays z in a Cartesian diagram with logarithmic scale

CALCulate<Chn>:FORMat:WQUType <Unit>

Selects the physical unit of the displayed trace.

Suffix:

<Chn> Channel number used to identify the active trace

Parameters:

<Unit> POWER | VOLTage
Power or voltage units
*RST: POWER

Example:

```
CALC4:PAR:SDEF 'Ch4Tr1', 'b1'
```

Create channel 4 and a trace named Ch4Tr1 to measure the wave quantity b_1 . The trace becomes the active trace in channel 4.

```
CALC4:FORM:WQUType VOLT
```

Select voltage units for the created trace (identified by the suffix 4).

Manual operation: See "[Show as](#)" on page 236

8.3.1.8 CALCulate:GDAPerture...

The CALCulate:GDAPerture... commands configure the group delay measurement.

CALCulate<Chn>:GDAPerture:SCOunt <Steps>

Defines an aperture for the calculation of the group delay as an integer number of frequency sweep steps.

Suffix:

<Chn> Channel number used to identify the active trace

Parameters:

<Steps> Number of steps
 Range: 1 to 10000
 *RST: 10

Example:

```
*RST; :CALC:FORM GDEL
Select group delay calculation for the active trace.
CALC:GDAP:SCO 15
Select an aperture of 15 steps.
```

Manual operation: See "[Aperture Points](#)" on page 257

8.3.1.9 CALCulate:IAverage**CALCulate<Chn>:IAverage[:STATE] <Boolean>**

Turns infinite averaging on or off.

The averaging mode can be selected using `CALCulate<Chn>:IAverage:MODE`.

Suffix:

<Chn> Channel number used to identify the active trace

Parameters:

<Boolean> ON | OFF | 1 | 0
 *RST: 0

Manual operation: See "[Infinite Average/Restart](#)" on page 296

CALCulate<Chn>:IAverage:MODE <Mode>

Selects the quantities to be averaged if infinite averaging is enabled

(`CALCulate<Chn>:IAverage[:STATE] ON`).

Suffix:

<Chn> Channel number used to identify the active trace

Parameters:

<Mode> MAGPhase | REIMag
 Selects the averaging mode.

MAGPhase

Averaging of magnitude and phase (default) of the complex trace value

REIMag

Averaging of real and imaginary part of the complex trace value

Manual operation: See "Mode" on page 296

8.3.1.10 CALCulate:LIMit...

The `CALCulate:LIMit...` commands define the limit lines and control the limit check.

<code>CALCulate:LIMit:CIRClE:FAIL:ALL?</code>	647
<code>CALCulate:LIMit:FAIL:ALL?</code>	647
<code>CALCulate:LIMit:FAIL:DATA?</code>	647
<code>CALCulate<Chn>:LIMit:CIRClE[:STATe]</code>	647
<code>CALCulate<Chn>:LIMit:CIRClE:CLear</code>	648
<code>CALCulate<Chn>:LIMit:CIRClE:DATA</code>	648
<code>CALCulate<Chn>:LIMit:CIRClE:DISPlay[:STATe]</code>	648
<code>CALCulate<Chn>:LIMit:CIRClE:FAIL?</code>	649
<code>CALCulate<Chn>:LIMit:CIRClE:SOUNd[:STATe]</code>	649
<code>CALCulate<Chn>:LIMit:CLear</code>	649
<code>CALCulate<Chn>:LIMit:CONTRol[:DATA]</code>	649
<code>CALCulate<Chn>:LIMit:CONTRol:SHIFt</code>	650
<code>CALCulate<Chn>:LIMit:DATA</code>	651
<code>CALCulate<Chn>:LIMit:DCIRclE[:STATe]</code>	652
<code>CALCulate<Chn>:LIMit:DCIRclE:CLear</code>	652
<code>CALCulate<Chn>:LIMit:DCIRclE:DATA</code>	652
<code>CALCulate<Chn>:LIMit:DCIRclE:DISPlay[:STATe]</code>	653
<code>CALCulate<Chn>:LIMit:DELeTe:ALL</code>	653
<code>CALCulate<Chn>:LIMit:DISPlay[:STATe]</code>	653
<code>CALCulate<Chn>:LIMit:FAIL?</code>	654
<code>CALCulate<Chn>:LIMit:LOWer[:DATA]</code>	654
<code>CALCulate<Chn>:LIMit:UPPer[:DATA]</code>	654
<code>CALCulate<Chn>:LIMit:LOWer:FEED</code>	656
<code>CALCulate<Chn>:LIMit:UPPer:FEED</code>	656
<code>CALCulate<Chn>:LIMit:LOWer:SHIFt</code>	656
<code>CALCulate<Chn>:LIMit:UPPer:SHIFt</code>	656
<code>CALCulate<Chn>:LIMit:SEGMENT<Seg>:AMPLitude:START</code>	657
<code>CALCulate<Chn>:LIMit:SEGMENT<Seg>:AMPLitude:STOP</code>	657
<code>CALCulate<Chn>:LIMit:SEGMENT:COUNT?</code>	658
<code>CALCulate<Chn>:LIMit:SEGMENT<Seg>:FORMula</code>	658
<code>CALCulate<Chn>:LIMit:SEGMENT<Seg>:FORMula:STATe</code>	658
<code>CALCulate<Chn>:LIMit:SEGMENT<Seg>:INTERpol</code>	659
<code>CALCulate<Chn>:LIMit:SEGMENT<Seg>:STIMulus:START</code>	659
<code>CALCulate<Chn>:LIMit:SEGMENT<Seg>:STIMulus:STOP</code>	659
<code>CALCulate<Chn>:LIMit:SEGMENT<Seg>:TYPE</code>	660
<code>CALCulate<Chn>:LIMit:SOUNd[:STATe]</code>	661
<code>CALCulate<Chn>:LIMit:STATe</code>	661
<code>CALCulate<Chn>:LIMit:STATe:AREA</code>	661
<code>CALCulate<Chn>:LIMit:TTLout<Pt>[:STATe]</code>	662

CALCulate:LIMit:CIRClE:FAIL:ALL? [<RecallSet>]

Returns a 0 or 1 to indicate whether or not the circle limit check has failed for at least one channel in the referenced recall set. 0 represents pass and 1 represents fail

Query parameters:

<RecallSet> Recall set name; if omitted the active recall set is used

Usage: Query only

Manual operation: See "[Limit Check](#)" on page 318

CALCulate:LIMit:FAIL:ALL? [<RecallSet>]

Returns a 0 or 1 to indicate whether or not the limit line check has failed for at least one channel in the referenced recall set. 0 represents pass and 1 represents fail.

Query parameters:

<RecallSet> Recall set name; if omitted the active recall set is used

Usage: Query only

Manual operation: See "[Limit Check](#)" on page 306

CALCulate:LIMit:FAIL:DATA? <TraceName>, <LimitFailType>

Returns those sweep points that have caused a limit violation of the given <LimitFailType> for trace <TraceName>.

Query parameters:

<TraceName> Trace name, uniquely identifying the related trace

<LimitFailType> LIMit | RIPPlE | CIRClE
Limit (fail) type

Usage: Query only

CALCulate<Chn>:LIMit:CIRClE[:STATe] <Boolean>

Switches the circle limit check on or off.

Suffix:

<Chn> Channel number used to identify the active trace

Parameters:

<Boolean>

Example:

```
*RST; CALCulate:LIMit:CIRClE:DATA 0, 0, 0.5
```

Define a circle limit line centered around the origin of the polar diagram, assigning a radius of 0.5 U.

```
CALCulate:LIMit:CIRClE:STATe ON; FAIL?
```

Switch the limit check on and query the result.

Manual operation: See "[Limit Check](#)" on page 318

CALCulate<Chn>:LIMit:CIRClE:CLEar

Resets the circle test for the active trace of channel <Chn>.

Suffix:

<Chn> Channel number used to identify the active trace

Usage: Event

Manual operation: See ["Clear Test"](#) on page 320

CALCulate<Chn>:LIMit:CIRClE:DATA <CenterX>, <CenterY>, <Radius>

Defines a circle limit lines by its center coordinates and its radius.

Suffix:

<Chn> Channel number used to identify the active trace

Parameters:

<CenterX> Range: Virtually no restriction for center coordinates.
*RST: 0
Default unit: NN

<CenterY> Range: Virtually no restriction for center coordinates.
*RST: 0
Default unit: NN

<Radius> Range: Virtually no restriction for radius (use positive values).
*RST: 1
Default unit: NN

Example: See [CALCulate<Chn>:LIMit:CIRClE\[:STATe\]](#)

Manual operation: See ["Radius / Center X / Center Y"](#) on page 320

CALCulate<Chn>:LIMit:CIRClE:DISPlay[:STATe] <Boolean>

Displays or hides the circle limit line associated to the active trace.

Suffix:

<Chn> Channel number used to identify the active trace

Parameters:

<Boolean> ON | OFF - Circle limit line on or off.
*RST: OFF

Example: *RST; CALCulate:LIMit:CIRClE:DATA 0, 0, 0.5
Define a circle limit line centered around the origin of the polar diagram, assigning a radius of 0.5 U.
CALCulate:FORMat POLar
CALCulate:LIMit:CIRClE:DISPlay ON
Activate a polar diagram and show the circle limit line in the diagram.

Manual operation: See ["Show Limit Circle"](#) on page 318

CALCulate<Chn>:LIMit:CIRClE:FAIL?

Returns a 0 or 1 to indicate whether or not the circle limit check has failed. 0 represents pass and 1 represents fail

Tip: Use `CALCulate:CLIMits:FAIL?` to perform a composite (global) limit check.

Suffix:

<Chn> Channel number used to identify the active trace

Example:

See `CALCulate<Chn>:LIMit:CIRClE[:STATe]`

Usage:

Query only

Manual operation: See ["Limit Check"](#) on page 318

CALCulate<Chn>:LIMit:CIRClE:SOUNd[:STATe] <Boolean>

Switches the acoustic signal (fail beep) on or off. The fail beep is generated each time the analyzer detects an exceeded circle limit.

Suffix:

<Chn> Channel number used to identify the active trace

Parameters:

<Boolean> ON | OFF - Fail beep on or off.

*RST: OFF

Example:

`CALCulate:LIMit:CIRClE:STATe ON; SOUNd ON`

Switch the limit check on and activate the fail beep.

Manual operation: See ["Limit Fail Beep"](#) on page 320

CALCulate<Chn>:LIMit:CLEar

Resets the limit check results for the limit line test.

Suffix:

<Chn> Channel number used to identify the active trace

Usage:

Event

Manual operation: See ["Clear Test"](#) on page 307

CALCulate<Chn>:LIMit:CONTRol[:DATA] <StartStim>, <StopStim>[, ...]

Defines the stimulus values of the limit line and/or creates new limit line segments. See also [Chapter 5.4.1.1, "Rules for Limit Line Definition"](#), on page 123.

Rules for creating segments

The following rules apply to an active trace with n existing limit line segments:

- An odd number of values is rejected; an error message -109, "Missing parameter..." is generated.
- An even number of $2*k$ values updates or generates k limit line segments.
- For $n > k$ the stimulus values of all existing limit line segments no. 1 to k are updated, the existing limit line segments no. $k+1$, ..., n are deleted.
- For $n < k$ the stimulus values of the limit line segments no. 1 to n are updated, the limit line segments $n+1$, ..., k are generated with default response values (see `CALCulate<Chn>:LIMit:UPPer[:DATA]`, `CALCulate<Chn>:LIMit:LOWer[:DATA]`).

Note: The generated segments are upper or lower limit line segments, depending on the `CALCulate<Chn>:LIMit:SEGment<Seg>:TYPE` setting.

`CALCulate<Ch>:LIMit:CONTRol[:DATA]` does not overwrite the type setting.

Tip: To define additional new limit line segments without overwriting the old segments use `CALCulate<Chn>:LIMit:DATA`.

Suffix:

<Chn> Channel number used to identify the active trace

Parameters:

<StartStim>

<StopStim>

Pairs of stimulus values, each pair confining a limit line segment. See also [Chapter 5.4.1.1, "Rules for Limit Line Definition"](#), on page 123.

If not specified, the units are adjusted to the sweep type of the active channel (`[SENSe<Ch>:]SWEep:TYPE`).

Range: Virtually no restriction for limit segments.

*RST: A segment that is created implicitly, e.g. by means of `CALCulate<Ch>:LIMit:UPPer[:DATA]` or `CALCulate<Ch>:LIMit:LOWer[:DATA,]`, covers the maximum sweep range of the analyzer.

Example:

```
*RST; :CALC:LIM:CONT 1 GHz, 2 GHz
```

Select a lin. frequency sweep (default) and define an upper limit line segment in the stimulus range between 1 GHz and 2 GHz, using default response values (-40 dB).

```
CALC:LIM:DISP ON
```

Show the limit line segment in the active diagram.

Manual operation: See ["Segment List"](#) on page 309

CALCulate<Chn>:LIMit:CONTRol:SHIFt <LimShift>

Shifts an existing limit line in horizontal direction. See also [Chapter 5.4.1.1, "Rules for Limit Line Definition"](#), on page 123.

Suffix:

<Chn> Channel number used to identify the active trace

Setting parameters:

<LimShift> Offset value for the limit line
 Range: Virtually no restriction for limit segments
 Default unit: NN

Example:

```
*RST; :CALC:LIM:CONT 1 GHZ, 2 GHZ
```

Define a limit line segment in the stimulus range between 1 GHz and 2 GHz, using default response values.

```
CALC:LIM:CONT:SHIF 1; :CALC:LIM:CONT?
```

Shift the segment by 1 Hz. The modified limit line segment ranges from 1000000001 (Hz) to 2000000001 (Hz).

Usage: Setting only

Manual operation: See ["Shift Lines"](#) on page 308

CALCulate<Chn>:LIMit:DATA <Type>, <StartStim>, <StopStim>, <StartResp>, <StopResp>

Defines the limit line type, the stimulus and response values for a limit line with an arbitrary number of limit line segments. See [Chapter 5.4.1.1, "Rules for Limit Line Definition"](#), on page 123.

Note: In contrast to `CALCulate<Chn>:LIMit:CONTRol[:DATA]`, this command does not overwrite existing limit line segments. The defined segments are appended to the segment list as new segments.

Suffix:

<Chn> Channel number used to identify the active trace

Parameters:

<Type> Identifier for the type of the limit line segment:
 0 – limit line segment off, segment defined but no limit check performed.
 1 – upper limit line segment
 2 – lower limit line segment

Range: 0, 1, 2 (see above)

<StartStim>, <StopStim>, <StartResp>, <StopResp>
 Stimulus and response values of the first and last points of the limit line segment.
 The unit of the stimulus values is adjusted to the sweep type of the active channel (`[SENSe<Ch>:]SWEep:TYPE`), the unit of the ripple limit is adjusted to the format of the active trace (`CALCulate<Chn>:FORMat`).

Example: *RST; :CALC:LIM:CONT 1 GHZ, 1.5 GHZ
 Define an upper limit line segment in the stimulus range between 1 GHz and 1.5 GHz, using default response values.
 CALC:LIM:DATA 1, 1500000000, 2000000000, 2, 3
 Define an upper limit line segment in the stimulus range between 1.5 GHz and 2 GHz, assigning response values of +2 dB and +3 dB.
 CALC:LIM:DISP ON
 Show the limit line segment in the active diagram.

Manual operation: See "[Segment List](#)" on page 309

CALCulate<Chn>:LIMit:DCIRcle[:STATE] <Boolean>

Sets/queries the state of the display circle for the active trace of channel <Chn>.

The display circle is defined using `CALCulate<Chn>:LIMit:DCIRcle:DATA`.

Suffix:

<Chn> Channel number used to identify the active trace

Parameters:

<Boolean> If set to ON, only trace points within the display circle are shown at the GUI whenever the related trace is displayed in complex format.

Manual operation: See "[Limit to Circle On/Off](#)" on page 321

CALCulate<Chn>:LIMit:DCIRcle:CLEar

Resets the display circle to its default configuration (unit circle; show border: off; limit to circle: off).

Suffix:

<Chn> Channel number used to identify the active trace

Usage: Event

Manual operation: See "[Clear Circle](#)" on page 322

CALCulate<Chn>:LIMit:DCIRcle:DATA <CenterX>, <CenterY>, <Radius>

Defines the display circle for the active trace of channel <Chn>.

Suffix:

<Chn> Channel number used to identify the active trace

Parameters:

<CenterX> X position (real part) of the display circle's center

<CenterY> Y position (imaginary part) of the display circle's center

<Radius> Radius of the display circle

Manual operation: See "[Draw Circle / Radius, Center X, Center Y](#)" on page 322

CALCulate<Chn>:LIMit:DCIRcle:DISPlay[:STATe] <Boolean>

Sets/queries the visibility of the display circle for the active trace of channel <Chn>.

The display circle is defined using `CALCulate<Chn>:LIMit:DCIRcle:DATA`.

Suffix:

<Chn> Channel number used to identify the active trace

Parameters:

<Boolean> If set to ON, the line of the display circle is shown whenever the related trace is displayed in complex format.

Manual operation: See ["Show Border"](#) on page 321

CALCulate<Chn>:LIMit:DELeTe:ALL

Deletes all limit line segments.

Suffix:

<Chn> Channel number used to identify the active trace

Example:

```
*RST; :CALC:LIM:CONT 1 GHz, 1.5 GHz
```

Define an upper limit line segment in the stimulus range between 1 GHz and 1.5 GHz, using default response values.

```
CALC:LIM:DATA 1,1500000000, 2000000000,2,3
```

Define an upper limit line segment in the stimulus range between 1.5 GHz and 2 GHz, assigning response values of +2 dB and +3 dB.

```
CALC:LIM:DEL:ALL
```

Delete both created limit line segments.

Usage: Event

Manual operation: See ["Add / Insert / Delete / Delete All"](#) on page 310

CALCulate<Chn>:LIMit:DISPlay[:STATe] <Boolean>

Displays or hides the entire limit line (including all segments) associated to the active trace.

Suffix:

<Chn> Channel number used to identify the active trace

Parameters:

<Boolean> ON | OFF - Limit line on or off.

```
*RST: OFF
```

Example:

```
*RST; :CALC:LIM:CONT 1 GHz, 2 GHz
```

Define an upper limit line segment in the stimulus range between 1 GHz and 2 GHz, using default response values.

```
CALC:LIM:DISP ON
```

Show the limit line segment in the active diagram.

Manual operation: See ["Show Limit Line"](#) on page 305

CALCulate<Chn>:LIMit:FAIL?

Returns a 0 or 1 to indicate whether or not the limit check has failed. 0 represents pass and 1 represents fail

Tip: Use `CALCulate:CLIMits:FAIL?` to perform a composite (global) limit check.

Since V2.20 of the R&S ZND FW the result is automatically recalculated whenever a relevant setting is changed, i.e. a subsequent query will return the updated limit violation state.

Suffix:

<Chn> Channel number used to identify the active trace

Example:

```
*RST; :CALC:LIM:CONT 1 GHz, 2 GHz
```

Define an upper limit line segment in the stimulus range between 1 GHz and 2 GHz, using default response values.

```
CALC:LIM:STAT ON; FAIL?
```

Switch the limit check on and query the result.

```
CALC:LIM:STAT:AREA LEFT, TOP
```

For a subsequent check at the GUI or a hardcopy, move the pass/fail message to the top left position.

Usage: Query only

Manual operation: See "[Limit Check](#)" on page 306

CALCulate<Chn>:LIMit:LOWer[:DATA] <ResponseValue>, <ResponseValue>...

CALCulate<Chn>:LIMit:UPPer[:DATA] <StartResponse>, <StopResponse>[,<StartResponse>, <StopResponse>[,...]]

Sets/gets the response (y-axis) values of the lower/upper limit lines and/or creates new limit line segments. See also [Chapter 5.4.1.1, "Rules for Limit Line Definition"](#), on page 123.

Note that in contrast to commands addressing a single limit line segment <Seg> (such as `CALCulate<Chn>:LIMit:SEGment<Seg>:TYPE`), these commands **assume** that

- lower limit line segments are assigned even numbers (<Seg> = 2, 4, 6, ...) and
- upper limit line segments are assigned odd numbers (<Seg> = 1, 3, 5, ...).

`CALCulate<Chn>:LIMit:LOWer/UPPer` sets the type and response values of even/odd limit line segments and gets the response values of even/odd limit line segments - no matter what the current type of these segments actually is!

Both commands will only work, if the total number of limit line segments is even.

Rules for creating and updating segments

Suppose that the active trace is equipped with 2s limit line segments (of any type) and k pairs of response values are passed with the command.

- `CALCulate:LIMit:LOWer`
 - deletes "obsolete" limit line segments 2k+1, ..., 2s

- updates even limit line segments 2, 4, ..., 2s with type=lower and the given response values
- creates lower limit line segments 2s+2, 2s+4, ..., 2k with (type=lower and) the given response values
- creates "missing" upper limit line segments 2s+1, 2s+3, ..., 2k-1 with (type=upper and) default response values
- `CALCulate:LIMit:UPPer`
 - deletes "obsolete" limit line segments 2k+1, ..., 2s
 - updates odd limit line segments 1, 3, ..., 2s-1 with type=upper and the given response values
 - creates upper limit line segments 2s+1, 2s+3, ..., 2k-1 with (type=upper and) the given response values
 - creates "missing" lower limit line segments 2s+2, 2s+4, ..., 2k with (type=lower and) default response values

If $s > 0$, newly created lower/upper limit line segments inherit their start and stop stimuli from the limit line segment with the highest even/odd number. Otherwise their stimulus range is set to the entire sweep range.

See `CALCulate<Chn>:LIMit:CONTrol[:DATA]` on how to change the stimulus values of a limit line segment.

Suffix:

<Chn> Channel number used to identify the active trace

Parameters:

<StartResponse>, Pair(s) of response values. In the parameter list, item 2s-1 defines the "Start Response" and item 2s defines the "Stop Response" of upper/lower limit line segment $s = 1, 2, \dots$
 <StopResponse>, ... An odd number of values is rejected with an error message -109, "Missing parameter...".

Range: Virtually no restriction for limit segments.

*RST: Implicitly created segments are created with a default response value of -40dB.

Default unit: dB

Example:

```
CALC:LIM:LOW -10, 0, 0, -10
```

Define two limit line segments covering the entire sweep range. Two upper limit line segments with default response values are created in addition.

```
CALC:LIM:UPP 0, 10, 10, 0
```

Change the response values of the upper limit line segments .

```
CALC:LIM:DISP ON
```

Show the limit line segments in the active diagram.

Manual operation: See "[Segment List](#)" on page 309

CALCulate<Chn>:LIMit:LOWer:FEED <StimulusOffset>, <ResponseOffset>[, <TraceName>]

CALCulate<Chn>:LIMit:UPPer:FEED <StimulusOffset>, <ResponseOffset>[, <TraceName>]

Generates a lower or an upper limit line using the stimulus values of a data or memory trace and specified offset values.

Suffix:

<Chn> Channel number used to identify the active trace. This trace provides the stimulus data for the limit line unless another trace <TraceName> is specified.

Setting parameters:

<StimulusOffset> Stimulus offset value, used to shift all imported limit line segments in horizontal direction.

Default unit: NN

<ResponseOffset> Response offset value, used to shift all imported limit line segments in vertical direction.

Default unit: dB

<TraceName> Name of the selected trace as used e.g. in [CALCulate<Ch>:PARAmeter:SDEFine](#). If no trace name is specified the analyzer uses the active trace no. <Chn>.

Example:

`CALC:LIM:LOW:FEED 1 GHZ, -10`

Use the stimulus values of the active trace, shifted by 1 GHz to the right and decreased by -10 dB, to create a lower limit line.

`CALC:LIM:UPP:FEED 1 GHZ, 10`

Use the stimulus values of the active trace, shifted by 1 GHz to the right and increased by 10 dB, to create an upper limit line.

`CALC:LIM:LOW:SHIF -3; :CALC:LIM:CONT:SHIF 1 GHZ`

Shift the lower limit line by an additional -3 dB in vertical and by 1 GHz in horizontal direction. The upper limit line is also shifted.

Usage: Setting only

Manual operation: See "[Segment List](#)" on page 309

CALCulate<Chn>:LIMit:LOWer:SHIFt <LimShift>

CALCulate<Chn>:LIMit:UPPer:SHIFt <LimShift>

These commands shift all lower and upper limit line segments assigned to the active trace in vertical direction. Both commands shift **all** limit lines; they have the same functionality. See also [Chapter 5.4.1.1, "Rules for Limit Line Definition"](#), on page 123.

Suffix:

<Chn> Channel number used to identify the active trace

Setting parameters:

<LimShift> Response offset value for all limit line segments.
 Range: Virtually no restriction for limit segments
 Default unit: NN

Example: See `CALCulate<Chn>:LIMit:LOWer:FEED`

Usage: Setting only

Manual operation: See "[Shift Lines](#)" on page 308

`CALCulate<Chn>:LIMit:SEGment<Seg>:AMPLitude:STARt <Response>`

`CALCulate<Chn>:LIMit:SEGment<Seg>:AMPLitude:STOP <Response>`

These commands change the start or the stop response values (i.e. the response values assigned to the start or stop stimulus values) of a limit line segment. A segment must be created first to enable the commands (e.g. `CALCulate<Chn>:LIMit:DATA`). See also [Chapter 5.4.1.1, "Rules for Limit Line Definition"](#), on page 123.

Tip: To define the response values of several limit line segments with a single command, use `CALCulate<Chn>:LIMit:LOWer[:DATA]` or `CALCulate<Chn>:LIMit:UPPer[:DATA]`.

Suffix:

<Chn> Channel number used to identify the active trace

<Seg> Segment number

Parameters:

<Response> Response value
 Range: Virtually no restriction for limit segments
 *RST: The default response values of a segment that is created by defining its stimulus values only (e.g. by means of `CALCulate<Ch>:LIMit:CONTRol[:DATA]`), are -40 dB.
 Default unit: NN

Example:

```
CALC:LIM:DATA 1,1500000000, 2000000000,2,3
```

Define an upper limit line segment (segment no. 1) in the stimulus range between 1.5 GHz and 2 GHz, assigning response values of +2 dB and +3 dB.

```
:CALC:LIM:SEGM:AMPL:STAR 5; STOP 5; :CALC:LIM:SEGM:TYPE LMIN
```

Change the segment to a lower limit line segment with a constant response value of +5 dB.

```
CALC:LIM:DATA?
```

Query the type, the stimulus and response values of the created segment with a single command. The response is 2,1500000000,2000000000,5,5.

Manual operation: See "[Segment List](#)" on page 309

CALCulate<Chn>:LIMit:SEGMent:COUNT?

Returns the number of limit line segments, including enabled and disabled segments.

Suffix:

<Chn> Channel number used to identify the active trace

Example:

```
CALC:LIM:DATA 1,1500000000, 2000000000,2,3
Define an upper limit line segment (segment no. 1) in the stimu-
lus range between 1.5 GHz and 2 GHz, assigning response val-
ues of +2 dB and +3 dB.
CALC:LIM:SEGM:COUNT?
Query the number of segments. The response is 1.
```

Usage:

Query only

Manual operation: See "[Segment List](#)" on page 309

CALCulate<Chn>:LIMit:SEGMent<Seg>:FORMula <Formula>

Defines a custom formula for limit line segment <Seg> of the related trace.

The formula is only used, if `CALCulate<Chn>:LIMit:SEGMent<Seg>:FORMula` is set to ON.

Suffix:

<Chn> Channel number used to identify the active trace

<Seg> Segment number

Parameters:

<Formula> User-defined formula (string).
Allows for the same mathematical expressions as `CALCulate<Chn>:MATH[:EXPRession]:SDEFine`.

Example:

```
*RST
SENS:FREQ:STAR 1GHz
SENS:FREQ:STOP 3GHz
CALC:LIM:CONT 1GHz, 2GHz, 2GHz, 3GHz
CALC:LIM:SEGM1:FORM '22-(20/25.78)*StimVal/1e9'
CALC:LIM:SEGM1:FORM:STAT ON
CALC:LIM:SEGM2:FORM '15-(6/25.78)*StimVal/1e9'
CALC:LIM:SEGM2:TYPE LMIN
CALC:LIM:DISP ON
CALC:LIM:STAT ON
```

Manual operation: See "[Linear/Formula](#)" on page 312

CALCulate<Chn>:LIMit:SEGMent<Seg>:FORMula:STATe <State>

Defines whether a custom formula is used for limit line segment <Seg> of the related trace.

Suffix:

<Chn> Channel number used to identify the active trace

<Seg> Segment number
If you want to use a custom formula for a segment, use `CALCulate<Chn>:LIMit:CONTRol[:DATA]` to create it.

Parameters:

<State> **OFF (0)**
The line segment is a straight line, connecting the endpoints specified in the segment definition.

ON (1)
The line segment is defined by a custom formula. Use `CALCulate<Chn>:LIMit:SEGMENT<Seg>:FORMula` to specify the formula.

*RST: OFF

Example: See `CALCulate<Chn>:LIMit:SEGMENT<Seg>:FORMula` on page 658

Manual operation: See "Linear/Formula" on page 312

CALCulate<Chn>:LIMit:SEGMENT<Seg>:INTERpol <LimLineInterpolation>

"Interpolation" determines whether the limit line segment is interpolated linearly or logarithmically. The latter may be more suitable for logarithmic sweeps.

Suffix:

<Chn> Channel number used to identify the active trace

<Seg> Segment number

Parameters:

<LimLineInterpolation> LOGarithmic | LINear

Manual operation: See "Segment List" on page 309

CALCulate<Chn>:LIMit:SEGMENT<Seg>:STIMulus:START <FreqPowTime>**CALCulate<Chn>:LIMit:SEGMENT<Seg>:STIMulus:STOP <StimVal>**

These commands change the start and stop stimulus values (i.e. the smallest and the largest stimulus values) of a limit line segment. A segment must be created first to enable the commands (e.g. `CALCulate<Chn>:LIMit:DATA`). See also [Chapter 5.4.1.1, "Rules for Limit Line Definition"](#), on page 123.

Tip: To define the stimulus values of several limit line segments with a single command, use `CALCulate<Chn>:LIMit:CONTRol[:DATA]`.

Suffix:

<Chn> Channel number used to identify the active trace

<Seg> Segment number

Parameters:

<StimVal>

Stimulus value confining the limit line segment.

If specified, the unit of a stimulus value must in accordance with the sweep type of the active channel (`[SENSe<Ch>:]SWEep:TYPE`). Default units are *Hz* for frequency sweeps, *dBm* for power sweeps, and *s* for time sweeps. For CW mode sweeps, stimulus values are dimensionless.

Default unit: NN

Example:

```
CALC:LIM:DATA 1,1500000000, 2000000000,2,3
```

Define an upper limit line segment (segment no. 1) in the stimulus range between 1.5 GHz and 2 GHz, assigning response values of +2 dB and +3 dB.

```
CALC:LIM:SEGM:STIM:STAR 1GHZ; STOP 2 GHZ; :
```

```
CALC:LIM:SEGM:TYPE LMIN
```

Change the segment to a lower limit line segment with a stimulus range between 1 GHz and 2 GHz.

```
CALC:LIM:DATA?
```

Query the type, the stimulus and response values of the created segment with a single command. The response is 2,1000000000,2000000000,2,3.

Manual operation: See "[Segment List](#)" on page 309

CALCulate<Chn>:LIMit:SEGment<Seg>:TYPE <LimLineType>

Selects the limit line type for a limit line segment. This can be done before or after defining the stimulus and response values of the segment, however, a segment must be created first to enable this command (e.g `CALC:LIM:DATA`).

Note: The type command overwrites the `CALCulate<Chn>:LIMit:DATA` settings and is overwritten by them. It is not affected by the other commands in the `CALCulate<Chn>:LIMit...` subsystem defining stimulus and response values of limit lines.

Suffix:

<Chn>

Channel number used to identify the active trace

<Seg>

Segment number

Parameters:

<LimLineType>

LMIN | LMAX | OFF

Limit line type

Range: LMAX (upper limit line segment), LMIN (lower limit line segment), OFF (limit check switched off, limit line segment not deleted)

*RST: LMAX

Example: `*RST; :CALC:LIM:UPP 0, 0`
 Define an upper limit line segment across the entire sweep range, using a constant upper limit of 0 dBm.
`CALC:LIM:SEGM:TYPE LMIN`
 Turn the defined limit line segment into a lower limit line segment.

Manual operation: See "[Segment List](#)" on page 309

CALCulate<Chn>:LIMit:SOUND[:STATe] <Boolean>

Switches the acoustic signal (fail beep) on or off. The fail beep is generated each time the analyzer detects an exceeded limit.

Suffix:
 <Chn> Channel number used to identify the active trace

Parameters:
 <Boolean> ON | OFF - Fail beep on or off.
 *RST: OFF

Example: `CALC:LIM:STAT ON; SOUN ON`
 Switch the limit check on and activate the fail beep.

Manual operation: See "[Limit Fail Beep](#)" on page 307

CALCulate<Chn>:LIMit:STATe <Boolean>

Switches the limit check (including upper and lower limits) on or off.

Tip: Use `CALCulate<Ch>:LIMit:UPPer:STATe` or `CALCulate<Ch>:LIMit:LOWer:STATe` to switch on or off the individual limit checks for upper or lower limit lines.

Suffix:
 <Chn> Channel number used to identify the active trace

Parameters:
 <Boolean> ON | OFF - Limit check on or off.
 *RST: OFF

Example: `*RST; CALC:LIM:CONT 1 GHZ, 2 GHZ`
 Define an upper limit line segment in the stimulus range between 1 GHz and 2 GHz, using default response values.
`CALC:LIM:STAT ON; FAIL?`
 Switch the limit check on and query the result.

Manual operation: See "[Limit Check](#)" on page 306

CALCulate<Chn>:LIMit:STATe:AREA <HorizontalPos>, <VerticalPos>

Moves the limit check pass/fail message for the active trace <Chn> to one of nine pre-defined positions in the active diagram.

Suffix:	
<Chn>	Channel number used to identify the active trace
Parameters:	
<HorizontalPos>	LEFT MID RIGHT Horizontal position
<VerticalPos>	TOP MID BOTTOm Vertical position
Example:	See CALCulate<Chn>:LIMit:FAIL?
Manual operation:	See " Limit Check " on page 306

CALCulate<Chn>:LIMit:TTLout<Pt>[:STATe] <Boolean>

Switches the TTL pass/fail signals on or off. The signals are applied to the USER PORT as long as the active trace <Chn> is within limits, including the ripple limits.

See [Chapter 11.3.1.1, "USER PORT"](#), on page 1156.

Default values for new traces can be set using [SYSTem:TTLout<Pt>:STATus\[:STATe\]](#).

Suffix:	
<Chn>	Channel number used to identify the active trace
<Pt>	1 - TTL out pass 1 (pin 13 of USER PORT connector) 2 - TTL out pass 2 (pin 14 of USER PORT connector)
Parameters:	
<Boolean>	ON OFF - TTL output signal on or off. *RST: OFF
Example:	*RST; :CALC:LIM:CONT 1 GHZ, 2 GHZ Define an upper limit line segment in the stimulus range between 1 GHz and 2 GHz, using default response values. CALC:LIM:STAT ON; TTL2 ON Switch the limit check on and activate the TTL out pass 2 signal.
Manual operation:	See " TTL1 Pass / TTL2 Pass " on page 307

8.3.1.11 CALCulate:MARKer...

The `CALCulate:MARKer...` commands control the marker functions. The commands are device-specific and beyond what is specified in the SCPI subsystem `SOURce:MARKer...`

CALCulate:MARKer:COUPled[:STATe]	663
CALCulate:MARKer:COUPled:TYPE	664
CALCulate:MARKer:FUNCTion:BWIDth:GMCenter	664
CALCulate<Chn>:MARKer[:STATe]:AREA	665
CALCulate<Chn>:MARKer:DEFault:FORMat	665
CALCulate<Chn>:MARKer:MPEak:EXCURsion	666

CALCulate<Chn>:MARKer:MPEak:EXCursion:STATe.....	667
CALCulate<Chn>:MARKer:MPEak:THReshold.....	667
CALCulate<Chn>:MARKer:MPEak:THReshold:STATe.....	667
CALCulate<Chn>:MARKer:SEARch:BFILter:RESult[:STATe].....	668
CALCulate<Chn>:MARKer:SEARch:BFILter:RESult[:STATe]:AREA.....	668
CALCulate<Chn>:MARKer<Mk>:AOFF.....	668
CALCulate<Chn>:MARKer<Mk>:BWIDth.....	669
CALCulate<Chn>:MARKer<Mk>:DELTA[:STATe].....	670
CALCulate<Chn>:MARKer<Mk>:EXCursion.....	670
CALCulate<Chn>:MARKer<Mk>:EXCursion:STATe.....	671
CALCulate<Chn>:MARKer<Mk>:FORMat.....	671
CALCulate<Chn>:MARKer<Mk>:FUNction:BWIDth:MODE.....	672
CALCulate<Chn>:MARKer<Mk>:FUNction:CENter.....	672
CALCulate<Chn>:MARKer<Mk>:FUNction:DOMain:USER[:RANGe].....	673
CALCulate<Chn>:MARKer<Mk>:FUNction:DOMain:USER:SHOW.....	673
CALCulate<Chn>:MARKer<Mk>:FUNction:DOMain:USER:STARt.....	674
CALCulate<Chn>:MARKer<Mk>:FUNction:DOMain:USER:STOP.....	674
CALCulate<Chn>:MARKer<Mk>:FUNction:EXECute.....	674
CALCulate<Chn>:MARKer<Mk>:FUNction:RESult?.....	675
CALCulate<Chn>:MARKer<Mk>:FUNction:SPAN.....	675
CALCulate<Chn>:MARKer<Mk>:FUNction:STARt.....	676
CALCulate<Chn>:MARKer<Mk>:FUNction:STOP.....	676
CALCulate<Chn>:MARKer<Mk>:MODE.....	676
CALCulate<Chn>:MARKer<Mk>:NAME.....	677
CALCulate<Chn>:MARKer<Mk>:REFerence[:STATe].....	677
CALCulate<Chn>:MARKer<Mk>:REFerence:FORMat.....	678
CALCulate<Chn>:MARKer<Mk>:REFerence:MODE.....	678
CALCulate<Chn>:MARKer<Mk>:REFerence:NAME.....	679
CALCulate<Chn>:MARKer<Mk>:REFerence:TYPE.....	679
CALCulate<Chn>:MARKer<Mk>:REFerence:X.....	680
CALCulate<Chn>:MARKer<Mk>:REFerence:Y.....	680
CALCulate<Chn>:MARKer<Mk>:SEARch:TRACKing.....	681
CALCulate<Chn>:MARKer<Mk>:SEARch:FORMat.....	682
CALCulate<Chn>:MARKer<Mk>[:STATe].....	683
CALCulate<Chn>:MARKer<Mk>:TARGet.....	683
CALCulate<Chn>:MARKer<Mk>:THReshold.....	684
CALCulate<Chn>:MARKer<Mk>:THReshold:STATe.....	684
CALCulate<Chn>:MARKer<Mk>:TYPE.....	685
CALCulate<Chn>:MARKer<Mk>:X.....	686
CALCulate<Chn>:MARKer<Mk>:Y.....	686

CALCulate:MARKer:COUPled[:STATe] <Boolean>

Enables marker coupling to the active trace of the active channel or disables it.

Use `CALCulate:MARKer:COUPled:TYPE` to select the suitable coupling type before setting `CALCulate:MARKer:COUPled:STATe` to ON.

Parameters:

<Boolean> ON | OFF - enables or disables marker coupling.
 *RST: OFF

Example: Suppose that the active recall set contains traces Trc1 and Trc2, assigned to channels no. 1 and 2, respectively.

```
:CALC2:PAR:SEL 'TRC2'; :CALC2:MARK1 ON; MARK2 ON
```

Select Trc2 as the active trace of channel 2 and activate markers 1 and 2 for it. The default position for both markers is the center of the sweep range.

```
INSTRUMENT:NSELECT 2
```

Make channel 2 the active channel.

```
CALCulate:MARKer:COUPled:TYPE ALL
```

Select coupling type "All" (recall set-wide coupling).

```
CALC:MARK:COUP ON
```

Activate marker coupling to Trc2 (the active trace of the active channel). Automatically creates markers no. 1 and 2 on Trc1 and couples them to the respective markers of Trc2.

Manual operation: See ["Coupled Markers"](#) on page 325

CALCulate:MARKer:COUPled:TYPE <Type>

Selects the marker coupling type to be used in the current recall set.

Marker coupling is enabled using `CALCulate:MARKer:COUPled[:STATE] ON`. Changing the coupling type automatically disables marker coupling throughout the recall set.

Parameters:

<Type> ALL | CHANnel | DIAGram

Marker coupling mode

ALL

recall set-wide

CHANnel

channel-wide

DIAGram

diagram-wide

Example: See `CALCulate:MARKer:COUPled[:STATE]` on page 663

Manual operation: See ["Coupling Type"](#) on page 344

CALCulate:MARKer:FUNction:BWIDth:GMCenter <arg0>

Defines how bandfilter searches calculate the center frequency of the passband or stopband.

Parameters:

<arg0>

ON – use **geometric** mean of lower and upper band edge

OFF – use **arithmetic** mean

*RST: n/a (*RST does not affect the calculation rule; the factory setting is ON/geometric mean)

Manual operation: See ["Geometric Calculation of Bandfilter Center"](#) on page 527

CALCulate<Chn>:MARKer[:STATe]:AREA <HorizontalPos>, <VerticalPos>

Moves the marker info field for the active trace <Chn> to one of nine predefined positions in the active diagram.

Suffix:

<Chn> Channel number used to identify the active trace

Parameters:

<HorizontalPos> LEFT | MID | RIGHT
Horizontal position

<VerticalPos> TOP | MID | BOTTOm
Vertical position

Example: See [CALCulate<Chn>:MARKer<Mk>:Y](#)

Manual operation: See ["Mkr 1 ... Mkr 10"](#) on page 325

CALCulate<Chn>:MARKer:DEFault:FORMat <OutFormat>

Defines the default marker format of the selected channel's active trace.

New markers will be formatted with the default marker format; previously existing markers will be reformatted if (and only if) their marker format is set to (Trace) DEFault (using [CALCulate<Chn>:MARKer<Mk>:FORMat](#)).

Suffix:

<Chn> Channel number used to identify the active trace

Parameters:

<OutFormat> MLINear | MLOGarithmic | PHASe | POLar | GDELay | REAL | IMAGinary | SWR | LINPhase | LOGPhase | IMPedance | ADMittance | DEFault | COMPLex | MDB | MLPPhase | MDPHase | MIMPedance | PIMPedance | PADmittance | MADmittance | MPIMPedance | MPADmittance | INDX

DEFault means the default marker format is dynamically adjusted to the selected trace format ([CALCulate<Chn>:FORMat](#)).

For the other marker formats see the table below and the description in ["Marker Format"](#) on page 86.

*RST: DEFault

Manual operation: See [" Dflt Marker Frmt"](#) on page 259

SCPI	GUI
MLINear	"Lin Mag"
MLOGarithmic MDB (for R&S ZVR compatibility)	"dB Mag"

SCPI	GUI
PHASe	"Phase"
POLar COMPLex (for R&S ZVR compatibility)	"Real Imag"
GDELay	"Delay"
REAL	"Real"
IMAGinary	"Imag"
SWR	"SWR"
LINPhase MLPhase (for R&S ZVR compatibility)	"Lin Mag Phas"e
LOGPhase MDPhase (for R&S ZVR compatibility)	"dB Mag Phase"
IMPedance	"R + j X" for reflection measurement traces "R + j X series" for transmission measurement traces
PIMPedance	"R + j X", for reflection measurement traces "R + j X parallel" for transmission measurement traces
ADMittance	"G + j B" for reflection measurement traces "G + j B series" for transmission measurement traces
PADMittance	"G + j B" for reflection measurement traces "G + j B parallel" for transmission measurement traces
MIMPedance	"Imp Mag" for reflection measurement traces "Imp Mag series" for transmission measurement traces
MPIMPedance	"Imp Mag" for reflection measurement traces "Imp Mag parallel" for transmission measurement traces
MADMittance	"Adm Mag" for reflection measurement traces "Adm Mag series" for transmission measurement traces
MPADMittance	"Adm Mag" for reflection measurement traces "Adm Mag parallel" for transmission measurement traces
INDex	Index

CALCulate<Chn>:MARKer:MPEak:EXCursion <TargetSearchVal>

Defines a minimum excursion value for multiple peak searches.

Use `CALCulate<Chn>:MARKer:MPEak:EXCursion:STATe` to activate it.

Suffix:

<Chn> Channel number used to identify the active trace

Parameters:

<Value> Minimum peak excursion
The unit is derived from the active trace format and cannot be modified. Changing the trace format resets the excursion to a format-specific default value.

Manual operation: See "[Excursion Settings](#)" on page 335

CALCulate<Chn>:MARKer:MPEak:EXCursion:STATe <Boolean>

Activates or deactivates the minimum excursion for multiple peak searches.

Use `CALCulate<Chn>:MARKer:MPEak:EXCursion` to set the minimum peak excursion.

Suffix:

<Chn> Channel number used to identify the active trace

Parameters:

<Active> Boolean

Manual operation: See "[Excursion Settings](#)" on page 335

CALCulate<Chn>:MARKer:MPEak:THReshold <Value>

Defines a threshold value for multiple peak searches.

Use `CALCulate<Chn>:MARKer:MPEak:THReshold:STATe` to activate it.

Suffix:

<Chn> Channel number used to identify the active trace

Parameters:

<Value> Threshold value
The unit is derived from the active trace format and cannot be modified. Changing the trace format resets the threshold to a format-specific default value.

Manual operation: See "[Threshold Settings](#)" on page 335

CALCulate<Chn>:MARKer:MPEak:THReshold:STATe <Boolean>

Activates or deactivates the threshold for multiple peak searches.

Use `CALCulate<Chn>:MARKer:MPEak:THReshold` to set the threshold value.

Suffix:

<Chn> Channel number used to identify the active trace

Parameters:

<Active> Boolean

Manual operation: See ["Threshold Settings"](#) on page 335

CALCulate<Chn>:MARKer:SEARch:BFILter:RESult[:STATe] <Boolean>

Shows or hides the bandfilter search results in the diagram area.

Suffix:

<Chn> Channel number used to identify the active trace

Parameters:

<Boolean> ON - show the bandfilter search results. If no bandfilter search has been initiated before (`CALCulate<Chn>:MARKer<Mk>:FUNCTION:EXECute BFILter`), nothing is displayed.
OFF - hide the bandfilter search results.

*RST: OFF

Example: See `CALCulate<Chn>:MARKer<Mk>:BWIDth`

Manual operation: See ["Result Off"](#) on page 340

**CALCulate<Chn>:MARKer:SEARch:BFILter:RESult[:STATe]:AREA
<HorizontalPos>, <VerticalPos>**

Moves the bandfilter search info field for the active trace <Chn> to one of nine predefined positions in the active diagram.

Suffix:

<Chn> Channel number used to identify the active trace

Parameters:

<HorizontalPos> LEFT | MID | RIGHT
Horizontal position

<VerticalPos> TOP | MID | BOTTom
Vertical position

Example: See `CALCulate<Chn>:MARKer<Mk>:BWIDth`

Manual operation: See ["Bandpass Ref to Max"](#) on page 339

CALCulate<Chn>:MARKer<Mk>:AOFF

Removes all markers from all traces of the active recall set. The removed markers remember their properties (stimulus value, format, delta mode, number) when they are restored (`CALCulate<Chn>:MARKer<Mk>[:STATe] ON`). The marker properties are definitely lost if the associated trace is deleted.

Suffix:

<Chn> Channel number used to identify the active trace. If unspecified the numeric suffix is set to 1.

<Mk>	This numeric suffix is ignored and may be set to any value.
Example:	Suppose that the active recall set contains an active trace no. 1. <code>CALC:MARK1 ON; MARK2 ON</code> Create markers 1 and 2 and assign them to the trace no. 1. <code>CALC:MARK:AOFF</code> Remove both markers.
Usage:	Event
Manual operation:	See "All Off" on page 324

CALCulate<Chn>:MARKer<Mk>:BWIDth <Bandwidth>

Sets the bandfilter level for a bandfilter search or returns the results. The command is only available after a bandfilter search has been executed (`CALCulate<Chn>:MARKer<Mk>:FUNCTION:EXECute BFiLter`; see example below).

The response to the query `CALCulate<Chn>:MARKer<Mk>:BWIDth?` contains the following bandfilter search results:

- <Bandwidth> – bandwidth of the bandpass/bandstop region.
- <Center> – stimulus frequency at the center of the bandpass/bandstop region (the stimulus value of marker M4).
- <QualityFactor (3 dB)> – quality factor, i.e. the ratio between the center frequency and the 3-dB bandwidth.
- <Loss> – loss at the center of the bandpass/bandstop region (the response value of marker M4 at the time of the bandfilter search).
- <LowerEdge> – lower band edge.
- <UpperEdge> – upper band edge.

Tip: To obtain the <Quality Factor (BW)> result from the bandfilter info field, calculate the ratio <Center> / <Bandwidth>.

Suffix:

<Chn>	Channel number used to identify the active trace
<Mk>	This numeric suffix is ignored and may be set to any value because the bandfilter search functions always use markers M1 to M4.

Parameters:

<Bandwidth>	Difference between the band edges and the center response value of a bandfilter peak; must be negative for a bandpass search and positive for a bandstop search.
Range:	For bandpass: -100.00 dB to -0.01 dB; for bandstop: +0.01 dB to +100.00 dB
Increment:	0.03 dB
*RST:	-3 dB
Default unit:	dB

Example:

```
CALC:MARK:FUNC:BWID:MODE BST
Select a bandstop filter search.
CALC:MARK:FUNC:EXEC BFIL
Initiate the bandpass filter search for the current trace. Create
markers M1 to M4.
CALC:MARK:SEAR:BFIL:RES ON
Display the marker info field in the diaram area.
CALC:MARK:BWID 6
Select a 6-dB bandwidth for the bandstop.
CALC:MARK:BWID?
Query the results of the bandfilter search. An error message is
generated if the bandfilter search fails so that no valid results are
available.
CALC:MARK:SEAR:BFIL:RES:AREA LEFT, TOP
For a subsequent check at the GUI or a hardcopy, move the info
field to the top left position.
```

Manual operation: See "[Bandwidth](#)" on page 338

CALCulate<Chn>:MARKer<Mk>:DELTA[:STATe] <Boolean>

Switches the delta mode for marker <Mk> on trace no. <Chn> on or off. The marker must be created before using `CALCulate<Chn>:MARKer<Mk>[:STATe] ON`. If the active trace contains no reference marker, the command also creates a reference marker.

Suffix:

<Chn> Channel number used to identify the active trace
 <Mk> Marker number.

Parameters:

<Boolean> ON | OFF - Enables or disables the delta mode.
 *RST: OFF

Example: Suppose that the active recall set contains an active trace no. 1.

```
CALC:MARK ON
Create marker no. 1 and set it to the center of the sweep range.
CALC:MARK:DELT ON
Create a reference marker at the center of the sweep range and
set marker 1 to delta mode.
```

Manual operation: See "[Delta Mode](#)" on page 325

CALCulate<Chn>:MARKer<Mk>:EXCURsion <Value>

Defines a marker-specific minimum excursion value for peak searches.

Use `CALCulate<Chn>:MARKer<Mk>:EXCURsion:STATe` to activate it.

Suffix:

<Chn> Channel number used to identify the active trace

<Mk> Marker number

Parameters:

<Value> Minimum peak excursion
The unit is derived from the active trace format and cannot be modified. Changing the trace format resets the excursion to a format-specific default value.

Manual operation: See ["Excursion Settings"](#) on page 333

CALCulate<Chn>:MARKer<Mk>:EXCursion:STATe <Boolean>

Activates or deactivates the marker-specific minimum excursion for peak searches.

Use [CALCulate<Chn>:MARKer<Mk>:EXCursion](#) to set the minimum peak excursion.

Suffix:

<Chn> Channel number used to identify the active trace

<Mk> Marker number

Parameters:

<Active> Boolean

Manual operation: See ["Excursion Settings"](#) on page 333

CALCulate<Chn>:MARKer<Mk>:FORMat <OutFormat>

Sets/queries the output format for the (complex) value of the related marker.

Suffix:

<Chn> Channel number used to identify the active trace

<Mk> Marker number.

Parameters:

<OutFormat> MLINear | MLOGarithmic | PHASe | POLar | GDELay | REAL | IMAGinary | SWR | LINPhase | LOGPhase | IMPedance | ADMittance | DEFault | COMPLex | MDB | MLPHase | MDPHase | MIMPedance | PIMPedance | PADmittance | MADmittance | MPIMPedance | MPADmittance | INDX
DEFault means that the marker is formatted according to the related trace's default marker format (see [CALCulate<Chn>:MARKer:DEFault:FORMat](#)), which may not be set to DEFault (= trace format).
For the other marker formats, see [CALCulate<Chn>:MARKer:DEFault:FORMat](#) and the description in ["Marker Format"](#) on page 86.
*RST: DEFault

Manual operation: See ["Marker Format"](#) on page 326

CALCulate<Chn>:MARKer<Mk>:FUNCtion:BWIDth:MODE <BandfilterType>

Selects the bandfilter search mode. In contrast to manual control, bandfilter tracking is not automatically activated.

Suffix:

<Chn> Channel number used to identify the active trace

<Mk> This numeric suffix is ignored and may be set to any value because the bandfilter search functions always use markers M1 to M4.

Parameters:

<BandfilterType> BPASs | BStoP | BPRMarker | BSRMarker | BPABsolute | BSABsolute | NONE

Bandfilter search type:
 BPASs – Bandpass Search Ref to Max
 BStoP – Bandstop Search Ref to Max
 BPRMarker – Bandpass Search Ref to Marker
 BSRMarker – Bandstop Search Ref to Marker
 BPABsolute – Bandpass Absolute Level
 BSABsolute – Bandstop Absolute Level
 NONE – deactivate bandfilter search, result off

*RST: NONE

Example: See [CALCulate<Chn>:MARKer<Mk>:BWIDth](#)

Manual operation: See "[Bandpass Ref to Max](#)" on page 339

CALCulate<Chn>:MARKer<Mk>:FUNCtion:CENTer

Sets the center of the sweep range equal to the stimulus value of the marker <Mk> on trace no. <Chn>.

Suffix:

<Chn> Channel number used to identify the active trace

<Mk> Marker number.

Example:

```
*RST; :CALC:MARK ON
Create marker 1 in the center of the current sweep range and
assign it to trace no. 1.
CALC:MARK:FUNC:CENT
Leave the sweep range unchanged.
```

Usage: Event

Manual operation: See "[Center = Marker / Start = Marker / Stop = Marker / Span = Marker](#)" on page 342

CALCulate<Chn>:MARKer<Mk>:FUNcTion:DOMain:USER[:RANGe]
 <NumSearchRange>

Assigns a search range no. <NumSearchRange> to marker no <Mk> and selects the search range, e.g. in order to display range limit lines or define the start and stop values.

Suffix:

<Chn> Channel number used to identify the active trace

<Mk> Marker number.

Parameters:

<NumSearchRange> Number of the search range.

Range: 0 to 10 where 0 refers to the fixed full span search range (equal to the sweep range) and 1 to 10 refer to user-definable search ranges; see example.

*RST: 0 (reserved for full span search range)

Example:

```
CALC1:MARK1:FUNC:DOM:USER 2
```

Select the search range no. 2, assigned to marker no. 1 and trace no. 1.

```
CALC:MARK:FUNC:DOM:USER:START 1GHz
```

Set the start frequency of the search range to 1 GHz.

```
CALC:MARK:FUNC:DOM:USER:STOP 1.2GHz
```

Set the stop frequency of the search range to 1.2 GHz.

Manual operation: See "[Search Range](#)" on page 331

CALCulate<Chn>:MARKer<Mk>:FUNcTion:DOMain:USER:SHOW <Boolean>

Displays or hides range limit lines for the search range selected via [CALCulate<Chn>:MARKer<Mk>:FUNcTion:DOMain:USER\[:RANGe\]](#).

Suffix:

<Chn> Channel number used to identify the active trace

<Mk> Marker number.

Parameters:

<Boolean> ON | OFF - range limit lines on or off.

*RST: OFF

Example:

See [CALCulate<Chn>:STATistics:DOMain:USER](#)

Manual operation: See "[Range Limit Lines On](#)" on page 332

CALCulate<Chn>:MARKer<Mk>:FUNCtion:DOMain:USER:START
 <StarSearchRange>

CALCulate<Chn>:MARKer<Mk>:FUNCtion:DOMain:USER:STOP
 <StopSearchRange>

These commands define the start and stop values of the search range selected via [CALCulate<Chn>:MARKer<Mk>:FUNCtion:DOMain:USER\[:RANGE\]](#).

Suffix:

<Chn> Channel number used to identify the active trace

<Mk> Marker number.

Parameters:

<StopSearchRange> Beginning or end of the search range.

Range: Maximum allowed sweep range, depending on the instrument model and on the sweep type.

Default unit: NN

Example:

See [CALCulate<Chn>:MARKer<Mk>:FUNCtion:DOMain:USER\[:RANGE\]](#)

Manual operation: See "[Search Range](#)" on page 331

CALCulate<Chn>:MARKer<Mk>:FUNCtion:EXECute [<SearchMode>]

Selects a search mode for marker no. <Mk> and initiates the search. The marker must be created before using [CALCulate<Chn>:MARKer<Mk>\[:STATE\] ON](#) (exception: bandfilter search).

Suffix:

<Chn> Channel number used to identify the active trace

<Mk> Marker number. For a bandfilter search ([BFILter](#)) this numeric suffix is ignored and may be set to any value because the bandfilter search functions always use markers M1 to M4.

Setting parameters:

<SearchMode> MAXimum | MINimum | RPEak | LPEak | NPEak | TARGet | LTARGet | RTARGet | BFILter | MMAXimum | MMINimum | SPRogress

See list of parameters below.

Example:

Suppose that the active recall set contains an active trace no. 1.

```
CALC:MARK ON
```

Create marker M1 and assign it to trace no. 1.

```
CALC:MARK:FUNC:EXEC MAX; RES?
```

Move the created marker to the absolute maximum of the trace and query the stimulus and response value of the search result.

Usage:

Setting only

Manual operation: See "[Max / Min](#)" on page 329

The analyzer provides the following search modes:

Mode	Find...
MAXimum	Absolute maximum in the search range (see <code>CALCulate<Chn>:MARKer<Mk>:FUNCTION:DOMain:USER[:RANGE]</code>)
MINimum	Absolute maximum in the search range
RPEak	Next valid peak to the right of the current marker position
LPEak	Next valid peak to the left
NPEak	Next highest or lowest value among the valid peaks (next peak)
TARGET	Target value (see <code>CALCulate<Chn>:MARKer<Mk>:TARGET</code>)
RTARGET	Next target value to the right of the current marker position
LTARGET	Next target value to the left
BFILTER	Bandfilter search. The results are queried using <code>CALCulate<Chn>:MARKer<Mk>:BWIDth</code> .
MMAXimum or MMINimum	Multiple peak search
SPROgress	Sweep progress

`CALCulate<Chn>:MARKer<Mk>:FUNCTION:RESULT?`

Returns the result (stimulus and response value) of a search started by means of `CALCulate<Chn>:MARKer<Mk>:FUNCTION:EXECute`. The search must be executed before the command is enabled.

Suffix:

<Chn> Channel number used to identify the active trace

<Mk> This numeric suffix is ignored and may be set to any value.

Example: See `CALCulate<Chn>:MARKer<Mk>:FUNCTION:EXECute`

Usage: Query only

Manual operation: See "Max / Min" on page 329

`CALCulate<Chn>:MARKer<Mk>:FUNCTION:SPAN`

Sets the sweep span of the sweep range equal to the absolute value of the first coordinate of the active delta marker <Mk> on trace no. <Chn>.

Suffix:

<Chn> Channel number used to identify the active trace

<Mk> Marker number.

- Example:** `*RST; :CALC:MARK ON; MARK:DELTA ON`
 Create marker 1 in the center of the current sweep range and enable the delta mode.
`CALC:MARK:X 300MHZ`
 Increase the stimulus value of the delta marker by 300 MHz.
`CALC:MARK:FUNC:SPAN`
 Set the sweep range equal to 300 MHz. The sweep range starts at the reference marker position, i.e. in the center of the analyzer's frequency range.
- Usage:** Event
- Manual operation:** See "[Center = Marker / Start = Marker / Stop = Marker / Span = Marker](#)" on page 342

CALCulate<Chn>:MARKer<Mk>:FUNCtion:START
CALCulate<Chn>:MARKer<Mk>:FUNCtion:STOP

These command sets the beginning (. . .START) and the end (. . .STOP) of the sweep range equal to the stimulus value of the marker <Mk> on trace no. <Chn>.

Suffix:

<Chn> Channel number used to identify the active trace

<Mk> Marker number.

- Example:** `*RST; :CALC:MARK ON`
 Create marker 1 in the center of the current sweep range and assign it to trace no. 1.
`CALC:MARK:FUNC:STAR`
 Divide the sweep range in half, starting at the current marker position. As an alternative:
`CALC:MARK:FUNC:STOP`
 Divide the sweep range in half, ending at the current marker position.

Usage: Event

Manual operation: See "[Center = Marker / Start = Marker / Stop = Marker / Span = Marker](#)" on page 342

CALCulate<Chn>:MARKer<Mk>:MODE <Mode>

Sets marker no. <Mk> to continuous or discrete mode. The marker doesn't have to be created before (`CALCulate<Chn>:MARKer<Mk>[:STATe] ON`), the mode can be assigned in advance.

Suffix:

<Chn> Channel number used to identify the active trace

<Mk> Marker number.

Parameters:

<Mode> CONTInuous | DISCcrete
 CONTInuous - marker can be positioned on any point of the trace, and its response values are obtained by interpolation.
 DISCcrete - marker can be set to discrete sweep points only.
 *RST: CONT

Example:

Suppose that the active recall set contains an active trace no. 1.
 CALC:MARK:MODE DISC; :CALC:MARK2:MODE CONT
 Create marker 1 in discrete mode and marker 2 in continuous mode.
 CALC:MARK ON; MARK2 ON
 Display the two markers. Due to the different modes the horizontal positions can be different.

Manual operation: See "[Discrete](#)" on page 327

CALCulate<Chn>:MARKer<Mk>:NAME <MarkerName>

Defines a name for marker no. <Mk>. The marker doesn't have to be created before ([CALCulate<Chn>:MARKer<Mk>\[:STATE\] ON](#)), the name can be assigned in advance.

Suffix:

<Chn> Channel number used to identify the active trace
 <Mk> Marker number.

Parameters:

<MarkerName> Marker name (string parameter)
 *RST: 'M1' for marker no. 1 etc.

Example:

Suppose that the active recall set contains an active trace no. 1.
 CALC:MARK:NAME '&\$% 1'; :CALC:MARK ON
 Create marker 1 named "&\$% 1" and display the marker .
 CALC:MARK:REF ON
 CALC:MARK:REF:NAME 'Reference'
 Display the reference marker and rename it "Reference".

Manual operation: See "[Marker Name](#)" on page 326

CALCulate<Chn>:MARKer<Mk>:REFerence[:STATE] <Boolean>

Creates the reference marker and assigns it to trace no. <Chn>.

Suffix:

<Chn> Channel number used to identify the active trace
 <Mk> This numeric suffix is ignored and may be set to any value.

Parameters:

<Boolean> ON | OFF - creates or removes the marker.
 *RST: OFF

Example: Suppose that the active recall set contains an active trace no. 1.
`CALC:MARK:REF ON; :CALC:MARK ON`
 Create the reference marker and marker 1 and assign them to trace no. 1. The default position of both markers is the center of the sweep range.

Manual operation: See "On" on page 324

CALCulate<Chn>:MARKer<Mk>:REFerence:FORMat <OutFormat>

Sets/queries the output format for the (complex) value of the reference marker.

Suffix:

<Chn> Channel number used to identify the active trace

<Mk> This numeric suffix is ignored and may be set to any value.

Parameters:

<OutFormat> MLINear | MLOGarithmic | PHASe | POLar | GDELay | REAL |
 IMAGinary | SWR | LINPhase | LOGPhase | IMPedance |
 ADMittance | DEFault | COMPLex | MDB | MLPPhase |
 MDPHase | MIMPedance | PIMPedance | PADmittance |
 MADmittance | MPIMPedance | MPADmittance | INDX

DEFault means the reference marker is formatted according the related trace's default marker format (see [CALCulate<Chn>:MARKer:DEFault:FORMat](#)).

For the other marker formats, see [CALCulate<Chn>:MARKer:DEFault:FORMat](#) and the description in "Marker Format" on page 86.

*RST: DEFault

Manual operation: See "Marker Format" on page 326

CALCulate<Chn>:MARKer<Mk>:REFerence:MODE <Mode>

Sets the reference marker to continuous or discrete mode. The marker doesn't have to be created before ([CALCulate<Chn>:MARKer<Mk>\[:STATe\] ON](#)), the mode can be assigned in advance.

Suffix:

<Chn> Channel number used to identify the active trace

<Mk> This numeric suffix is ignored and may be set to any value.

Parameters:

<Mode> CONTinuous | DISCrete

CONTinuous - marker can be positioned on any point of the trace, and its response values are obtained by interpolation.

DISCrete - marker can be set to discrete sweep points only.

*RST: CONT

Example: Suppose that the active recall set contains an active trace no. 1.
`CALC:MARK:REF:MODE DISC`
`CALC:MARK2:REF:MODE CONT`
 Create the reference marker in discrete mode and marker 2 in continuous mode.
`CALC:MARK:REF ON; :CALC:MARK2 ON`
 Display the two markers. Due to the different modes the horizontal positions can be different.

Manual operation: See "[Discrete](#)" on page 327

`CALCulate<Chn>:MARKer<Mk>:REFerence:NAME <MarkerName>`

Defines a name for the reference marker. The marker doesn't have to be created before (`CALCulate<Chn>:MARKer<Mk>[:STATe] ON`), the name can be assigned in advance.

Suffix:

<Chn> Channel number used to identify the active trace
 <Mk> This numeric suffix is ignored and may be set to any value.

Parameters:

<MarkerName> Marker name (string parameter)
 *RST: 'R'

Example: See `CALCulate<Chn>:MARKer<Mk>:NAME`

Manual operation: See "[Marker Name](#)" on page 326

`CALCulate<Chn>:MARKer<Mk>:REFerence:TYPE <Mode>`

Sets the marker mode of the related reference marker. The marker must be created before using `CALCulate<Chn>:MARKer<Mk>:REFerence[:STATe] ON`.

Suffix:

<Chn> Channel number used to identify the active trace
 <Mk> This numeric suffix is ignored and may be set to any value.

Parameters:

<Mode> NORMal | FIXed | ARBitrary
 See `CALCulate<Chn>:MARKer<Mk>:TYPE`.
 *RST: NORMal

Example: `CALC:MARK:REF ON; :CALC:MARK:REF:TYPE FIX`
 Create the reference marker and display it in the center of the sweep range as a fixed marker.
`CALC:MARK:REF:X 1GHz`
 Shift the marker horizontally. The response value remains fixed.

Manual operation: See "[Marker Mode](#)" on page 327

CALCulate<Chn>:MARKer<Mk>:REFerence:X <StimulusValue>[, <Seg>[, <MeasPoint>]]

In NORMal or FIXed marker mode (see [CALCulate<Chn>:MARKer<Mk>:TYPE](#)) this command sets or gets the stimulus value of the reference marker. In ARbitrary mode this is only true if the X axis represents the stimulus. For all other trace formats (see [CALCulate<Chn>:FORMat](#)) it sets or gets the X position of the reference marker, which is decoupled from the marker stimulus in this case.

Suffix:

<Chn> Channel number used to identify the active trace

<Mk> This numeric suffix is ignored and may be set to any value.

Parameters:

<StimulusValue> If the marker mode of the related marker is ARbitrary and the trace format is complex (Polar, Smith, inverted Smith), this is the real part $\text{Re}(z_M)$ of the marker value z_M . In any other case, it is the marker's stimulus value.

If the marker mode is ARbitrary and the trace format is complex, the value range is -1 to +1. Otherwise -9.9E+11 Hz to +9.9E+11 Hz for frequency sweeps, -999 dBm to +999 dBm for power sweeps, 0 s to 127500 s for time sweeps and 1 to 100001 for CW mode.

Setting parameters:

<Seg> For a segmented frequency sweep with overlapping segments, you can assign the reference marker to a particular segment. If specified, the <Seg> number must be valid and the <StimulusValue> must be inside the segment.

<Point> For a segmented frequency sweep with overlapping segments or with segments that have multiple sweep points at the same frequency, you can assign the reference marker to a particular segment <Seg> and sweep point <Point>. If specified, the <Seg> and <Point> numbers must be valid and the <StimulusValue> must be inside the segment.

Example:

Suppose that the active recall set contains an active trace no. 1 and that the sweep range for a frequency sweep starts at 1 GHz.

```
CALC:MARK:REF ON
```

Create the reference marker and display it in the center of the sweep range.

```
CALC:MARK:REF:X 1GHz
```

Set the reference marker to the beginning of the sweep range.

```
CALC:MARK:REF:Y?
```

Query the measurement value at the reference marker position.

Manual operation: See "[Mkr <i> Stimulus / Ref Mkr Stimulus](#)" on page 324

CALCulate<Chn>:MARKer<Mk>:REFerence:Y <RefResponseValue>

Sets or gets the (response) value of the related reference marker.

The marker must be created before using `CALCulate<Chn>:MARKer<Mk>:REFerence[:STATE] ON`.

Setting this value is only possible in ARbitrary mode (see `CALCulate<Chn>:MARKer<Mk>:REFerence:TYPE`). For NORMal and FIXed mode markers it is read-only.

Suffix:

<Chn> Channel number used to identify the active trace
 <Mk> This numeric suffix is ignored and may be set to any value.

Parameters:

<RefResponseValue> See `CALCulate<Chn>:MARKer<Mk>:Y`
 Default unit: NN

Example: See `CALCulate<Chn>:MARKer<Mk>:REFerence:X`

Manual operation: See "Mkr <i> Arb. Response / Ref Mkr Arb. Response" on page 324

CALCulate<Chn>:MARKer<Mk>:SEARch:TRACking <Boolean>

This command is only available if a search mode is active (`CALCulate<Chn>:MARKer<Mk>:FUNction:EXECute ...`)

It enables or disables tracking, which causes the search logic of the related marker(s) to be repeated after each sweep.

Tip: If the current search mode is a bandfilter or multiple peak search this command enables or disables the corresponding tracking.

Suffix:

<Chn> Channel number used to identify the active trace
 <Mk> Number of an existing marker.
 If a bandfilter search or a multiple peak search is active, tracking recalculates the whole marker set for each sweep and hence this suffix is ignored.

Parameters:

<Boolean> ON | OFF - enables or disables the marker tracking mode.
 *RST: OFF

Example: Suppose the active recall set contains an active trace no. 1.
`CALC:MARK ON; :CALC:MARK:FUNC:EXEC MAXimum`
 Create marker no. 1 and assign it to trace no. 1. Activate a maximum search for marker no. 1.
`CALC:MARK:SEAR:TRAC ON`
 Enable the tracking mode for the created marker.

Manual operation: See "Tracking" on page 330

CALCulate<Chn>:MARKer<Mk>:SEARch:FORMat <SearchFormat>

Selects the format in which the target value shall be specified (see [CALCulate<Chn>:MARKer<Mk>:TARGet](#) on page 683).

Each marker may have a different target format. The table below gives an overview on how a complex target value $z = x + jy$ is converted.

Target Format	Description	Formula
MLINear	Magnitude of z, unconverted.	$ z = \sqrt{x^2 + y^2}$
MLOGarithmic	Magnitude of z in dB	$\text{Mag}(z) = 20 \log z \text{ dB}$
PHASe	Phase of z	$\varphi(z) = \arctan(y/x)$
UPHase	Unwrapped phase of z comprising the complete number of 360° phase rotations	$\Phi(z) = \varphi(z) + 2k \cdot 360^\circ$
REAL	Real part of z	$\text{Re}(z) = x$
IMAGinary	Imaginary part of z	$\text{Im}(z) = y$
SWR	(Voltage) Standing Wave Ratio	$\text{SWR} = (1 + z) / (1 - z)$
DEFault	Identical to trace format. Note: the Smith and Polar traces use "Lin Mag" as the default format for target value.	-

Suffix:

<Chn> Channel number used to identify the active trace

<Mk> Marker number.

Parameters:

<SearchFormat> MLINear | MLOGarithmic | PHASe | UPHase | REAL | IMAGinary | SWR | DEFault

Identifies the search format for the target value of the marker. See table above.

*RST: DEFault

Example: Suppose channel 1's selected trace is POLar and marker 1 isn't yet created

```
:CALCULATE1:MARKER1 ON
Create/enable Marker 1
:CALCulate1:MARKer1:FUNCTION:SElect TARGET
Select TARGeT search mode for marker 1
:CALCulate1:MARKer1:SEARCh:FORMat?
Query the target format of marker 1. The result is DEF and for
polar diagrams the default target format is "Phase".
:CALCulate1:MARKer1:FUNCTION:TARGET?
Query for the default target value; for "Phase" this is 0 (degrees)
:CALCulate1:MARKer1:SEARCh:FORMat MLOGarithmic
Change the target search format to dB magnitude
:CALCulate1:MARKer1:FUNCTION:TARGET?
Query for the default target value; for dB magnitude this is 0 (dB)
:CALCulate1:MARKer1:FUNCTION:TARGET -3
Set the target value to -3 dB
:CALCulate1:MARKer1:FUNCTION:EXECute
Execute the target search for marker 1
:CALCulate1:MARKer1:FUNCTION:RESult?
Query for the results.
```

Manual operation: See "[Target Format](#)" on page 336

CALCulate<Chn>:MARKer<Mk>[:STATe] <Boolean>

Creates the marker numbered <Mk> and assigns it to trace no. <Chn>.

Suffix:

<Chn> Channel number used to identify the active trace

<Mk> Marker number. If unspecified the numeric suffix is set to 1.

Parameters:

<Boolean> ON | OFF – creates or removes the marker.

*RST: OFF

Example: Suppose that the active recall set contains an active trace no. 1.

```
CALC:MARK ON; MARK2 ON
```

Create markers 1 and 2 and assign them to trace no. 1. The default position of both markers is the center of the sweep range.

Manual operation: See "[On](#)" on page 324

CALCulate<Chn>:MARKer<Mk>:TARGeT <TargetSearchVal>

Defines the target value for the target search of marker no. <Mk>, which can be activated using `CALCulate<Chn>:MARKer<Mk>:FUNCTION:EXECute TARGeT`.

Suffix:

<Chn> Channel number used to identify the active trace

<Mk> Marker number.

Parameters:

<TargetSearchVal> Target search value of marker no. <Mk>. The value range and reset value depend on the selected target format (see [CALCulate<Chn>:MARKer<Mk>:SEARCH:FORMat](#) on page 682).

Example:

```
CALC:MARK ON
```

Create marker no. 1 and display it in the center of the sweep range.

```
:CALC:MARK:TARG -10; FUNC:EXEC TARG
```

Define a target search value of -10 dB and start the target search.

```
CALC:MARK:X?
```

Query the stimulus value corresponding to the target search result.

Manual operation: See "[Target Value](#)" on page 336

CALCulate<Chn>:MARKer<Mk>:THReshold <Value>

Defines a marker-specific threshold value for (single) peak searches.

Use [CALCulate<Chn>:MARKer<Mk>:THReshold:STATe](#) to activate it.

Suffix:

<Chn> Channel number used to identify the active trace

<Mk> Marker number

Parameters:

<Value> Threshold value
The unit is derived from the active trace format and cannot be modified. Changing the trace format resets the threshold to a format-specific default value.

Manual operation: See "[Threshold Settings](#)" on page 333

CALCulate<Chn>:MARKer<Mk>:THReshold:STATe <Active>

Activates or deactivates the marker-specific threshold for (single) peak searches.

Use [CALCulate<Chn>:MARKer<Mk>:THReshold](#) to set the threshold value.

Suffix:

<Chn> Channel number used to identify the active trace

<Mk> Marker number

Parameters:

<Active> Boolean

Manual operation: See "[Threshold Settings](#)" on page 333

CALCulate<Chn>:MARKer<Mk>:TYPE <Mode>

Sets the marker mode for the related marker. The marker must be created before using `CALCulate<Chn>:MARKer<Mk>[:STATe] ON`.

Suffix:

<Chn> Channel number used to identify the active trace

<Mk> Marker number.

Parameters:

<Mode> NORMal | FIXed | ARBitary

NORMal: If tracking is enabled (`CALCulate<Chn>:MARKer<Mk>:SEARCh:TRACking ON`), the marker's stimulus value `CALCulate<Chn>:MARKer<Mk>:X?` is updated automatically with every sweep, otherwise it is fixed. The marker position `CALCulate<Chn>:MARKer<Mk>:Y?` is adjusted to the corresponding response value, i.e. the marker is always positioned on the trace.

The marker's stimulus value can be set using `CALCulate<Chn>:MARKer<Mk>:X`; the marker automatically follows the trace.

FIXed: freezes the marker at the position determined by the current stimulus and response value. The response value stored with the marker is not adjusted to subsequent sweeps. Tracking is disabled. Stimulus and response value are stored with the marker; they are not adjusted to subsequent sweeps and trace format changes.

The marker stimulus can be set using `CALCulate<Chn>:MARKer<Mk>:X`, but the response value remains fixed.

ARBitary: freezes the marker at the position determined by the current stimulus and response value. Tracking is disabled. The marker stores the stimulus value and – in addition – its X and Y coordinates in the current marker format (see `CALCulate<Chn>:MARKer<Mk>:FORMat`).

The marker position can be set using `CALCulate<Chn>:MARKer<Mk>:X` and `CALCulate<Chn>:MARKer<Mk>:Y`. If, in the current trace format, the X axis represents the stimulus, the marker's stimulus value is adjusted accordingly. Otherwise the marker's stimulus value remains unchanged. Switching between trace formats resets the marker position to the response value at the marker's stimulus value.

*RST: NORMal

Example:

```
CALC:MARK ON; :CALC:MARK:TYPE FIX
```

Create marker 1 and display it in the center of the sweep range as a fixed marker.

```
CALC:MARK:X 1GHz
```

Shift the marker horizontally. The response value remains fixed.

Manual operation: See "Marker Mode" on page 327

CALCulate<Chn>:MARKer<Mk>:X <StimulusValue>[, <Seg>[, <MeasPoint>]]

If the mode of the related marker is NORMal or FIXed (see [CALCulate<Chn>:MARKer<Mk>:TYPE](#)), this command sets or gets the marker's stimulus value.

In ARBbitrary mode this is only true if the X axis represents the stimulus. For all other trace formats (see [CALCulate<Chn>:FORMat](#)) it sets or gets the X position of the marker, which is decoupled from the marker stimulus in this case.

Suffix:

<Chn> Channel number used to identify the active trace

<Mk> Marker number

Parameters:

<StimulusValue> If the marker mode of the related marker is ARBbitrary and the trace format is complex (Polar, Smith, inverted Smith), this is the real part $\text{Re}(z_M)$ of the marker value z_M . In any other case, it is the marker's stimulus value.

If the marker mode is ARBbitrary and the trace format is complex, the value range is -1 to +1. Otherwise -9.9E+11 Hz to +9.9E+11 Hz for frequency sweeps, -999 dBm to +999 dBm for power sweeps, 0 s to 127500 s for time sweeps and 1 to 100001 for CW mode.

Setting parameters:

<Seg> For a segmented frequency sweep with overlapping segments, you can assign the marker to a particular segment. If specified, the <Seg> number must be valid and the <StimulusValue> must be inside the segment.

<Point> For a segmented frequency sweep with overlapping segments or with segments that have multiple sweep points at the same frequency, you can assign the marker to a particular segment <Seg> and sweep point <Point>. If specified, the <Seg> and <Point> numbers must be valid and the <StimulusValue> must be inside the segment.

Example:

Suppose that the active recall set contains an active trace no. 1 and the sweep range for a frequency sweep starts at 1 GHz.

```
CALC:MARK ON
```

Create marker no. 1 and display it in the center of the sweep range.

```
CALC:MARK:X 1GHz
```

Set the marker to the beginning of the sweep range.

Manual operation: See "Mkr <i>Stimulus / Ref Mkr Stimulus" on page 324

CALCulate<Chn>:MARKer<Mk>:Y <ResponseValue>

Sets or gets the (response) value of the related marker.

The marker must be created before using `CALCulate<Chn>:MARKer<Mk>[:STATe] ON`.

Setting this value is only possible in ARBitrary mode (see `CALCulate<Chn>:MARKer<Mk>:TYPE`). For NORMal and FIXed mode markers it is read-only.

Suffix:

<Chn> Channel number used to identify the active trace

<Mk> Marker number.

Parameters:

<ResponseValue> **Setting (ARBitrary mode only):** sets the vertical position of the marker in Y units of the current trace format.

Query: returns the marker position formatted according to the current marker format (see `CALCulate<Chn>:MARKer<Mk>:FORMat`), i.e. as displayed in the marker info field (1 return value per row in the response column). Indetermined result values are returned as a sequence of dashes (-----). This may occur in ARBitrary mode, if the transformation between trace format and marker format requires a concrete stimulus value.

Default unit: NN

Example:

Suppose that the active recall set contains an active trace no. 1.
`CALC:MARK ON`

Create marker no. 1 and display it in the center of the sweep range.

`CALC:MARK:Y?`

Query the measurement value at the marker position.

`CALC:MARK:STAT:AREA LEFT, TOP`

For a subsequent check at the GUI or a hardcopy, move the info field to the top left position.

Manual operation: See "Mkr <i> Arb. Response / Ref Mkr Arb. Response" on page 324

8.3.1.12 CALCulate:MATH...

The `CALCulate:MATH...` commands permit processing of measured data in numerical expression format. The operators are +, -, *, / and use of constants and data arrays are permitted.

<code>CALCulate<Chn>:MATH[:EXPRession]:SDEFine</code>	688
<code>CALCulate<Chn>:MATH:FORMatted[:EXPRession]:SDEFine</code>	688
<code>CALCulate<Chn>:MATH:FUNCTion</code>	689
<code>CALCulate<Chn>:MATH:FORMatted:FUNCTion</code>	689
<code>CALCulate<Chn>:MATH:MEMorize</code>	690
<code>CALCulate<Chn>:MATH:STATe</code>	690
<code>CALCulate<Chn>:MATH:FORMatted:STATe</code>	690
<code>CALCulate<Chn>:MATH:WUNit[:STATe]</code>	691

CALCulate<Chn>:MATH[:EXPRession]:SDEFine <Expression>

CALCulate<Chn>:MATH:FORMatted[:EXPRession]:SDEFine <Expression>

Defines a mathematical trace for the active trace, using a string expression.

- The expression in the first command refers to raw, unformatted trace data (complex data). In order to apply it, **CALCulate<Chn>:MATH:FUNCTION** must be set to **NORMAL** and **CALCulate<Chn>:MATH:STATE** must be set to **ON**.
- The expression in the second command refers to formatted trace data. In order to apply it, **CALCulate<Chn>:MATH:FORMatted:FUNCTION** must be set to **NORMAL** and **CALCulate<Chn>:MATH:FORMatted:STATE** must be set to **ON**.

Trace math for unformatted and formatted trace data can be used at the same time.

Suffix:

<Chn> Channel number used to identify the active trace

Parameters:

<Expression> Operands, operators and functions; see table below.

Example:

```
*RST; :CALC:MATH:MEM
```

Copy the current state of the default trace 'Trc1' to a memory trace named 'Mem2[Trc1]'. The memory trace is not displayed.

```
CALC:MATH:SDEF 'Trc1 / Mem2[Trc1]'
```

Define a mathematical trace, dividing the raw complex data trace by the stored memory trace. The mathematical trace is not displayed.

```
CALC:MATH:STAT ON
```

Display the mathematical trace instead of the active data trace.

Manual operation: See "[Expression builder](#)" on page 276

Expressions defined via **CALCulate<Ch>:MATH[:EXPRession]:SDEFine** or **CALCulate<Chn>:MATH:FORMatted[:EXPRession]:SDEFine** may contain the following elements:

Type	Complete List	Description
Operands	<Trace name> activeTrc Mem[activeTrc]	All traces and memory traces of the active recall set Active trace Active memory trace assigned to the active trace
Constants	e, pi 1, -1.2, 8e9 1 + 2j, 2 + 1e-9j	Constants Real values in decimal or exponential format Complex numbers
Operators	- + , - , * , / , ^	Basic arithmetic operations; ^ for exponentiation
Functions	linMag (), dBMag (), Arg (), Re (), Im (), log (), ln (), tan (), atan (), sin (), asin (), cos (), acos (), Min (... , ...), Max (... , ...)	Mathematical functions with one or two arguments

Type	Complete List	Description
Special Functions	StimVal	Current stimulus value (see description of operators for User Defined Math)
Brackets	()	Priority of operations in complex expressions

CALCulate<Chn>:MATH:FUNCTION <Mode>**CALCulate<Chn>:MATH:FORMatted:FUNCTION <Mode>**

Defines a simple mathematical trace based on the active trace and its active memory trace. The first command applies to raw, unformatted trace data (complex data), the second to formatted trace data. Both methods can be combined.

To apply the trace math, the corresponding mathematical mode must be switched on using `CALCulate<Chn>:MATH:STATe ON` and/or `CALCulate<Chn>:MATH:FORMatted:STATe ON`.

Note: Use `CALCulate<Chn>:MATH[:EXPRession]:SDEFine` and/or `CALCulate<Chn>:MATH:FORMatted[:EXPRession]:SDEFine` to define general math traces.

Suffix:

<Chn> Channel number used to identify the active trace

Parameters:

<Mode> NORMAL | ADD | SUBTract | MULTipty | DIVide
 NORMAL – Math. trace = active data trace
 ADD – Math. trace = data + memory
 SUBTract – Math. trace = data - memory
 MULTipty – Math. trace = data * memory
 DIVide – Math. trace = data / memory
 When set to `NORMal`, the corresponding mathematical mode is turned `OFF`, otherwise it is turned `ON`.
 *RST: `NORMal`

Example:

```
*RST; :CALC:MATH:MEM
```

Copy the current state of the default trace 'Trc1' to a memory trace named 'Mem2[Trc1]'. The memory trace is not displayed.

```
CALC:MATH:FUNC DIV
```

Define a mathematical trace, dividing the raw complex data trace trace by the stored memory trace. The mathematical trace is displayed instead of the active data trace.

```
CALC:MATH:STAT?
```

The response is 1 (mathematical mode for unformatted trace data switched on, mathematical trace displayed).

Manual operation: See "`Data / <Mem>`, `Data - <Mem>`" on page 275

CALCulate<Chn>:MATH:MEMorize

Copies the current state of the active data trace to a memory trace. If a mathematical trace is active, the data trace associated with the mathematical trace is copied. The memory trace is named `Mem<n>[<Data_Trace>]` where `<n>` counts all data and memory traces in the active recall set in chronological order, and `<Data_Trace>` is the name of the associated (copied) data trace.

The exact function of the command depends on the number of memory traces associated to the active data trace:

- If no memory trace is associated to the active trace, a new memory trace is generated.
- If several memory traces are associated to the active trace, the current measurement data overwrites the last generated or changed memory trace.

Note: To copy a trace to the memory without overwriting an existing memory trace or define a memory trace name, use [TRACe:COPI](#)

`<MemTraceName>, <DataTraceName>`. To copy an active mathematical trace use [TRACe:COPI:MATH](#) `<MemTraceName>, <DataTraceName>`

Suffix:

`<Chn>` Channel number used to identify the active trace

Example:

```
*RST; :CALC:MATH:MEM
```

Copy the current state of the default trace 'Trc1' to a memory trace named 'Mem2[Trc1]'. The memory trace is not displayed.

```
DISP:WIND:TRAC2:FEED 'Mem2[Trc1]'
```

Display the created memory trace in the active diagram area (diagram area no. 1).

Usage: Event

Manual operation: See "[Data to <Destination>](#)" on page 271

CALCulate<Chn>:MATH:STATe <Boolean>**CALCulate<Chn>:MATH:FORMatted:STATe <Boolean>**

Activates or deactivates trace math for unformatted and/or formatted trace data, i.e. the trace formulae defined via [CALCulate<Chn>:MATH\[:EXPRession\]:SDEFine](#) and/or [CALCulate<Chn>:MATH:FORMatted\[:EXPRession\]:SDEFine](#), respectively.

When trace math is active either for unformatted or formatted data, the resulting mathematical trace is calculated and displayed instead of the active data trace.

Suffix:

`<Chn>` Channel number used to identify the active trace

Parameters:

`<Boolean>`
 ON – apply trace math on the
 OFF – display the active data trace

```
*RST: OFF
```

Example: ***RST**; :**CALC**:**MATH**:**MEM**
 Copy the current state of the default trace 'Trc1' to a memory trace named 'Mem2[Trc1]'. The memory trace is not displayed.
CALC:**MATH**:**SDEF** 'Trc1 / Mem2[Trc1]'
 Define a mathematical trace, dividing the complex data trace by the stored complex memory trace. The mathematical trace is not displayed.
CALC:**MATH**:**STAT** **ON**
 Display the mathematical trace instead of the active data trace.

Manual operation: See "[Trace Math](#)" on page 274

CALCulate<Chn>:**MATH**:**WUNit**[:**STATe**] <Boolean>

Controls the conversion and formatting of the mathematic expression defined via [CALCulate](#)<Chn>:**MATH**[:**EXPRession**]:**SDEFine**.

Suffix:

<Chn> Channel number used to identify the active trace

Parameters:

<Boolean>

ON –"Result is Wave Quantity" enabled: the analyzer assumes that the result of the mathematical expression represents a voltage.

OFF –"Result is Wave Quantity" disabled: the analyzer assumes that the result of the mathematical expression is dimensionless.

***RST**: **OFF**

Example:

***RST**; **SWE**:**TYPE** **POW**

CALC:**PAR**:**SDEF** 'Trc1', 'a1'

Reset the instrument, activate a power sweep, and select a wave quantity a₁ for the trace Trc1.

DISP:**WIND**:**TRAC**:**FEED** 'Trc1'

Display the generated trace in the active window.

CALC:**MATH**:**SDEF** 'StimVal'; **STAT** **ON**

Define a mathematical trace and display it instead of the active data trace.

CALC:**MATH**:**WUN** **ON**

Take into account that the stimulus value is a voltage (derived from the source power) rather than a dimensionless quantity.

The y-axis range of the mathematical trace now exactly corresponds to the power sweep range.

Manual operation: See "[Result is Wave Quantity](#)" on page 278

8.3.1.13 **CALCulate**:**PARAmeter**...

The **CALCulate**:**PARAmeter**... commands assign names and measurement parameters to traces. The commands are device-specific.

CALCulate:PARAmeter:DELeTe:ALL.....	692
CALCulate:PARAmeter:DELeTe:MEMory.....	692
CALCulate<Ch>:PARAmeter:CATalog?.....	692
CALCulate<Ch>:PARAmeter:CATalog:SENDEd?.....	693
CALCulate<Ch>:PARAmeter:DEFine:SGRoup.....	693
CALCulate<Ch>:PARAmeter:DELeTe.....	694
CALCulate<Ch>:PARAmeter:DELeTe:CALL.....	695
CALCulate<Ch>:PARAmeter:DELeTe:CMEMory.....	695
CALCulate<Ch>:PARAmeter:DELeTe:SGRoup.....	695
CALCulate<Ch>:PARAmeter:MEASure.....	696
CALCulate<Ch>:PARAmeter:MEASure:SENDEd.....	697
CALCulate<Ch>:PARAmeter:SDEFine.....	697
CALCulate<Ch>:PARAmeter:SDEFine:SENDEd.....	699
CALCulate<Ch>:PARAmeter:SELeT.....	700

CALCulate:PARAmeter:DELeTe:ALL

Deletes all traces in all channels of the active recall set, including the default trace `Trc1` in channel 1. The manual control screen shows "No Trace".

Example: See `CALCulate<Ch>:PARAmeter:DELeTe`

Usage: Event

Manual operation: See "Delete Trace" on page 266

CALCulate:PARAmeter:DELeTe:MEMory

Deletes all memory traces in all channels.

Usage: Event

Manual operation: See "Delete All Mem" on page 273

CALCulate<Ch>:PARAmeter:CATalog?

Returns the trace names and measurement parameters of all traces assigned to a particular channel.

The result is a string containing a comma-separated list of trace names and measurement parameters, e.g. 'CH4TR1, S11, CH4TR2, S12'. The measurement parameters are returned according to the naming convention of `CALCulate<Ch>:PARAmeter:SDEFine`. The order of traces in the list reflects their creation time: The oldest trace is the first, the newest trace is the last trace in the list.

Suffix:
 <Ch> Channel number. If unspecified the numeric suffix is set to 1.

Example: `CALC4:PAR:SDEF 'Ch4Tr1', 'S11'`
 Create channel 4 and a trace named Ch4Tr1 to measure the input reflection coefficient S_{11} .
`CALC4:PAR:CAT?`
 Query the traces assigned to channel 4. If Ch4Tr1 is the only trace assigned to channel 4, the response is 'CH4TR1,S11'.

Usage: Query only

CALCulate<Ch>:PARAmeter:CATalog:SENDED?

Returns the trace names and measurement parameters of all traces assigned to a particular channel.

Similar to `CALCulate<Ch>:PARAmeter:CATalog?`, but in presence of balanced ports this command distinguishes between

- single-ended S-parameters for **logical** ports ($S_{SS<Lj>}$)
- "raw" single-ended S-parameters referring to **physical** ports ($S_{<Pi><Pj>}$)

Suffix:
 <Ch> Channel number. If unspecified the numeric suffix is set to 1.

Usage: Query only

CALCulate<Ch>:PARAmeter:DEFine:SGRoup <LogicalPort1>[, <LogicalPort2>]...

Creates the traces for all S-parameters associated with a group of logical ports (S-parameter group). The traces can be queried using `CALCulate<Ch>:DATA:SGRoup?`.

Traces must be selected to become active traces; see `CALCulate<Ch>:PARAmeter:SElect`.

Note: Each channel can contain a single S-parameter group only. Defining a new S-parameter group deletes the previous one. Use `CALCulate<Ch>:PARAmeter:DElete:SGRoup` on page 695 to delete the current S-group explicitly.

Suffix:
 <Ch> Channel number. <Ch> may be used to reference a previously defined channel. If <Ch> does not exist, it is generated with default channel settings.

Parameters:
 <LogicalPort1> Logical (balanced or unbalanced) port numbers. The port numbers must be in ascending order, their number is limited by the test ports of the analyzer. With n logical port numbers, the command generates n^2 traces. The traces correspond to the following S-parameters:
 $S_{<log_port1><log_port1>}, S_{<log_port1><log_port2>} \dots S_{<log_port1><log_port<n>}$
 ...
 $S_{<log_port<n>><log_port1>}, S_{<log_port<n>><log_port2>} \dots S_{<log_port<n>><log_port<n>}$

e.g. S_{11} , S_{12} , S_{21} , S_{22} for $\langle \text{log_port1} \rangle = 1$, $\langle \text{log_port2} \rangle = 2$. If only one logical port $\langle \text{log_port1} \rangle$ is specified, a single trace with the reflection coefficient $S_{\langle \text{log_port1} \rangle \langle \text{log_port1} \rangle}$ is created.

Trace names

The generated traces are assigned the following trace names:

$\langle \text{Ch_name} \rangle_SG_S\langle \text{log_port1} \rangle\langle \text{log_port1} \rangle$,

$\langle \text{Ch_name} \rangle_SG_S\langle \text{log_port1} \rangle\langle \text{log_port2} \rangle \dots$

$\langle \text{Ch_name} \rangle_SG_S\langle \text{log_port1} \rangle\langle \text{log_port}\langle n \rangle \rangle \dots \langle \text{Ch_name} \rangle_SG_S\langle \text{log_port}\langle n \rangle \rangle\langle \text{log_port1} \rangle$,

$\langle \text{Ch_name} \rangle_SG_S\langle \text{log_port}\langle n \rangle \rangle\langle \text{log_port2} \rangle \dots$

$\langle \text{Ch_name} \rangle_SG_S\langle \text{log_port}\langle n \rangle \rangle\langle \text{log_port}\langle n \rangle \rangle$,

e.g. Ch1_SG_S11 , Ch1_SG_S12 , Ch1_SG_S21 , Ch1_SG_S22

for $\langle \text{Ch_name} \rangle = \text{Ch1}$, $\langle \text{log_port1} \rangle = 1$, $\langle \text{log_port2} \rangle = 2$. The trace names are displayed in the "Channel Manager" and in the "Trace Manager" dialogs where they can be changed manually.

The $\langle \text{Ch_name} \rangle$ is defined via

```
CONFigure:CHANnel<Ch>:NAME '<Ch_name>'
```

Trace names are important for referencing the generated traces; see program example below.

$\langle \text{LogicalPort2} \rangle$

Example:

```
CALC2:PAR:DEF:SGR 1,2
```

Create channel 2 and four traces to measure the two-port S-parameters S_{11} , S_{12} , S_{21} , S_{22} . The traces are not displayed.

```
DISP:WIND:TRAC2:FEED 'Ch2_SG_S11'
```

```
DISP:WIND:TRAC3:FEED 'Ch2_SG_S12'
```

```
DISP:WIND:TRAC4:FEED 'Ch2_SG_S21'
```

```
DISP:WIND:TRAC5:FEED 'Ch2_SG_S22'
```

Display the four traces in the diagram no. 1.

```
INIT2:CONT OFF; :INIT2:IMMediate; *OPC
```

Perform a complete sweep in channel no. 2 to ensure the traces are completely "filled" with data.

```
CALC2:DATA:SGR? SDAT
```

Retrieve all four traces as unformatted data (real and imaginary part at each sweep point). The analyzer first returns the complete S_{11} trace, followed by the S_{12} , S_{21} , and S_{22} traces.

```
CALC2:PAR:DEL:SGR
```

Delete the previously created port group.

Manual operation: See "All S-Params" on page 223

CALCulate<Ch>:PARAMeter:DELeTe <TraceName>

Deletes a trace with a specified trace name and channel.

Suffix:

$\langle \text{Ch} \rangle$ Channel number.

Setting parameters:

<TraceName> Trace name, e.g. 'Trc4'. See "Rules for trace names" in [Chapter 6.5.1.3, "Trace Manager Dialog"](#), on page 267.

Example:

```
CALCulate4:PARAMeter:SDEFine 'Ch4Tr1', 'S11'
```

Create channel 4 and a trace named Ch4Tr1 to measure the input reflection coefficient S_{11} .

```
CALCulate4:PAR:CAT?
```

Query the traces assigned to channel 4. Ch4Tr1 is the only trace assigned to channel 4, so the response is 'CH4TR1,S11'.

```
CALCulate4:PARAMeter:SDEFine 'CH4TR2', 'S21';
SDEFine 'CH4TR3', 'S12'; SDEFine 'CH4TR4', 'S22'
```

Create three more traces for the remaining 2-port S-parameters.

```
CALCulate4:PARAMeter:DELeTe 'CH4TR1'
```

Delete the first created trace.

```
CALCulate4:PARAMeter:DELeTe:CALL
```

Delete the remaining three traces in channel 4.

```
CALCulate:PARAMeter:DELeTe:ALL
```

Delete all traces, including the default trace Trc1 in channel 1.

Usage: Setting only

Manual operation: See "[Delete Trace](#)" on page 266

CALCulate<Ch>:PARAMeter:DELeTe:CALL

Deletes all traces in channel no. <Ch>.

Suffix:

<Ch> Channel number

Example: See [CALCulate<Ch>:PARAMeter:DELeTe](#)

Usage: Event

Manual operation: See "[Delete Trace](#)" on page 266

CALCulate<Ch>:PARAMeter:DELeTe:CMEMory

Deletes all memory traces in channel <Ch>.

Suffix:

<Ch> Channel number

Usage: Event

CALCulate<Ch>:PARAMeter:DELeTe:SGRoup

Deletes a group of logical ports (S-parameter group), previously defined via [CALCulate<Ch>:PARAMeter:DEFine:SGRoup](#).

Suffix:	
<Ch>	Channel number. <Ch> may be used to reference a previously defined channel. If <Ch> does not exist, it is generated with default channel settings.
Example:	See <code>CALCulate<Ch>:PARAmeter:DEFine:SGRoup</code>
Usage:	Event

`CALCulate<Ch>:PARAmeter:MEASure <TraceName>, <Result>`

Assigns a measurement result to an **existing** trace. The query returns the result assigned to the specified trace (no second parameter; see example).

Note: To create a new trace and at the same time assign the attributes, use `CALCulate<Ch>:PARAmeter:SDEFine`. To display the trace, create a diagram (`DISPlay[:WINDow<Wnd>][:STATE] ON`) and assign the trace to this diagram (`DISPlay[:WINDow<Wnd>]:TRACe<WndTr>:FEED`); see example below.

Traces must be selected to become active traces; see `CALCulate<Ch>:PARAmeter:SElect`. `CALCulate<Ch>:PARAmeter:CATalog?` returns a list of all defined traces. You can open the "Trace Manager" dialog to obtain an overview of all channels and traces, including the traces that are not displayed.

Suffix:	
<Ch>	Channel number of an existing channel containing the referenced trace.
Parameters:	
<TraceName>	Trace name, string variable, e.g. 'Trc4'. See "Rules for trace names" in "Table Area" on page 268. Trace names must be unique across all channels and diagrams.
<Result>	Measurement parameter (string variable); see Table 8-4. A query of a wave quantity 'xy' returns 'xyD<n><Detector>', where <n> numbers the source (drive) port, and <Detector> denotes the detector setting. A query of a ratio 'x/y' returns 'xD<n>/yD<m><Detector>', where <n> and <m> number the source ports
Example:	<pre>CALC4:PAR:SDEF 'Ch4Tr1', 'S11'</pre> <p>Create channel 4 and a trace named Ch4Tr1 to measure the input reflection coefficient S_{11}.</p> <pre>CALC4:PAR:MEAS 'Ch4Tr1', 'a1'</pre> <p>Change the measurement parameter of the trace and measure the wave quantity a_1.</p> <pre>CALC4:PAR:MEAS? 'Ch4Tr1'</pre> <p>Query the measured quantity. The response is 'A1D1SAM'.</p>
Manual operation:	See "S-Parameter (selector)" on page 222

CALCulate<Ch>:PARAmeter:MEASure:SENDED <TraceName>, <Result>

Assigns a measurement result to an **existing** trace. The query returns the result assigned to the specified trace (no second parameter; see example).

Similar to [CALCulate<Ch>:PARAmeter:MEASure](#), but in presence of balanced ports this command distinguishes between

- single-ended S-parameters for **logical** ports ($SSS<Lj>$)
- "raw" single-ended S-parameters referring to **physical** ports ($S<Pi><Pj>$)

Suffix:

<Ch> Channel number

Setting parameters:

<TraceName> Trace name

<Result> Measured quantity

Manual operation: See "[S-Parameter \(selector\)](#)" on page 222

CALCulate<Ch>:PARAmeter:SDEFine <TraceName>, <Result>

Creates a trace and assigns a channel number, a name and a measurement parameter to it. The trace becomes the active trace in the channel but is not displayed.

Note: To display the trace defined via [CALCulate<Ch>:PARAmeter:SDEFine](#), create a diagram ([DISPlay\[:WINDow<Wnd>\]\[:STATe\] ON](#)) and assign the trace to this diagram ([DISPlay\[:WINDow<Wnd>\]:TRACe<WndTr>:FEED](#)); see example below. [CALCulate<Ch>:PARAmeter:MEASure](#) changes the measurement result of an existing trace.

To select an existing trace as the active trace, use [CALCulate<Ch>:PARAmeter:SElect](#). You can open the trace manager to obtain an overview of all channels and traces, including the traces that are not displayed.

Tip: This command has no query form. Use [CALCulate<Ch>:PARAmeter:MEASure<TraceName>](#) to query the measurement result of the trace. [CALCulate<Ch>:PARAmeter:CATalog?](#) returns a list of all defined traces.

Suffix:

<Ch> Channel number. <Ch> may be used to reference a previously defined channel. If <Ch> does not exist, it is generated with default channel settings.

Setting parameters:

<TraceName> Trace name, string variable, e.g. 'Trc4'. See "Rules for trace names" in "Table Area" on page 268. Trace names must be unique across all channels and diagrams.
 If a trace with the selected trace name already exists, the analyzer behaves as follows: If the existing trace is assigned to the same channel as the new trace, it is deleted. The new trace is not automatically assigned to a diagram area; see note above. If the existing trace is assigned to a different channel, no new trace can be created. The analyzer returns an error message.

<Result> Measurement result (string variable), see table below.

Example:

```
CALC4:PAR:SDEF 'Ch4Tr1', 'S11'
```

Create channel 4 and a trace named Ch4Tr1 to measure the input reflection coefficient S_{11} .

```
DISP:WIND2:STAT ON
```

Create diagram area no. 2.

```
DISP:WIND2:TRAC:FEED 'CH4TR1'
```

Display the generated trace in diagram area no. 2.

Usage: Setting only

Manual operation: See "S-Parameter (selector)" on page 222

Table 8-4: String identifiers for measurement results

Note:	
All port numbers in a result identifier refer to logical (=DUT) ports ; to avoid ambiguities they must be represented by the same number of digits (e.g. S21 or S0201). The valid port numbers are determined by the channel's logical port configuration	
For a unidirectional R&S ZND (see Chapter 5.1.4.3, "R&S ZND: Unidirectional vs. Bidirectional Operation" , on page 75) logical port 2 (= physical port 2) cannot be used as the driving port and hence "reverse direction" wave quantities and related parameters are not available available.	
For details about the measurement results see Chapter 5.3, "Measurement Results" , on page 103.	
'S11' 'S12' ... 'S0101' ...	Single-ended S-parameters $S_{<i><j>}$ for logical (DUT) ports <i> and <j>. To avoid ambiguities, <i> and <j> must be specified with the same number of digits.
'SCD11' ...	S-parameters involving balanced ports must be specified in the form $S_{<m_i><m_j><i><j>}$, where <m_i> and <m_j> denote the port modes of the related logical ports <i> and <j>. In general, for the port modes <m_i><m_j> all pairs of D (differential, balanced), C (common, balanced) and S (single-ended, unbalanced) are allowed.
'Y11' ... 'YSS11' ... 'YCC11' ... 'YDD11' 'Z11' ... 'ZSS11' ... 'ZCC11' ... 'ZDD11' ...	Short-circuit Y-parameters and open-circuit Z-parameters with port modes and port numbers like for normal mode S-parameters. Selecting a parameter $Y_{...<n><m>}$ or $Z_{...<n><m>}$ sets the range of logical port numbers to be considered for the Y and Z-parameter measurement to <n>:<m>.
'Y-S11' ... 'Y-SSS11' ... 'Y-SCC11' ... 'Y-SDD11' 'Z-S11' ... 'Z-SSS11' ... 'Z-SCC11' ... 'Z-SDD11' ...	S-parameters converted to matched-circuit admittances and impedances with port modes and port numbers like for normal mode S-parameters. For transmission parameters, this refers to series resistances.

'Y-S12SER' 'Y-S12PAR' ... 'Z-S12SER' 'Z-S12PAR' ...	Converted transmission admittances and impedances, calculated as seriesChapter 5, "Concepts and Features" , on page 69 or parallel admittances/impedances.
'SHUNT-S12' 'SHUNT-S21'	Converted impedances measured using shunt-thru method.
'A1' ... 'A01' ... 'B1' ... 'B01' 'A1SAM' 'A1AVG' 'A1AMP'	Wave quantities A<meas>D1 (for a wave) and B<meas>D1. The strings SAM, AVG, AMP appended to the wave quantities denote a normal (sample, SAM), AVG Real Imag (AVG), or AVG Mag Phase (AMP) detector. The observation time for average detectors is set via [SENSe<Ch>:]SWEp:DETECTOR:TIME .
'A1D2' ... 'A01D02' ... 'B1D2' ... 'B01D02' 'A1D1SAM' 'A1D1AVG' 'A1D1AMP' ...	Wave quantities A<meas>D<drive> (for a wave) and B<meas>D<drive> (for b wave) for logical ports <meas> and <drive>. The strings SAM, AVG, AMP appended to the wave quantities denote a normal (sample, SAM), AVG Real Imag (AVG), or AVG Mag Phase (AMP) detector.
'B2/A1' ... 'B02/A01' 'B2/A1SAM' 'B2/A1AVG' 'B2/A1AMP' ...	Ratio of wave quantities with port numbers like for normal mode S-parameters. The strings SAM, AVG, AMP appended to the wave quantities denote a normal (sample, SAM), AVG Real Imag (AVG), or AVG Mag Phase (AMP) detector.
'B2D1/A1D1' ... 'B02D01/A01D01' 'B2D1/A1D1SAM' 'B2D1/A1D1AVG' 'B2D1/A1D1AMP' ...	Ratios of wave quantities with drive ports The strings SAM, AVG, AMP appended to the wave quantities denote a normal (sample, SAM), AVG Real Imag (AVG), or AVG Mag Phase (AMP) detector.
'IMB1-23' 'IMB23-1' 'IMB1-24' ...	Differential Imbalance parameters between a balanced and two single-ended logical ports
'KFAC21' 'KFAC12' ...	Stability factor K (for unbalanced ports only)
'MUF121' 'MUF112' ...	Stability factor 1 (for unbalanced ports only)
'MUF221' 'MUF212' ...	Stability factor 2 (for unbalanced ports only)
'Pmtr1D1' 'Pmtr2D2'	Power sensor measurement using a power meter 'Pmtr<no>' and analyzer source port 'D1' or 'D2'
Cu(P<Src Port>)<_lowercase_ext_dll_name>/<Task Type>/<Additional Input>	Traces calculated using external DLL <ext_dll_name>.dll.

*) Selecting a parameter Y...<n><m> or Z...<n><m> sets the range of port numbers to be considered for the Y and Z-parameter measurement to <n>:<m>.

CALCulate<Ch>:PARAmeter:SDEFine:SENDED <TraceName>, <Result>

Creates a trace and assigns a channel number, a name and a measurement parameter to it. The trace becomes the active trace in the channel but is not displayed.

Similar to [CALCulate<Ch>:PARAmeter:SDEFine](#), but in presence of balanced ports this command distinguishes between

- single-ended S-parameters for **logical** ports (SSS<Lj>)
- "raw" single-ended S-parameters referring to **physical** ports (S<Pi><Pj>)

Suffix:

<Ch> Channel number

Setting parameters:

<TraceName> Trace name

<Result> Measured quantity

Usage: Setting only

Manual operation: See "[S-Parameter \(selector\)](#)" on page 222

CALCulate<Ch>:PARAmeter:SElect <TraceName>

Selects an existing trace as the active trace of the channel. All trace commands without explicit reference to the trace name act on the active trace (e.g. [CALCulate<Chn>:FORMat](#)). [CALCulate<Ch>:PARAmeter:SElect](#) is also necessary if the active trace of a channel has been deleted.

Suffix:

<Ch> Channel number.

Parameters:

<TraceName> Trace name, e.g. 'Trc4'. See "Rules for trace names" in "[Table Area](#)" on page 268.

Example:

```
CALC4:PAR:SDEF 'Ch4Tr1', 'S11'
```

Create channel 4 and a trace named Ch4Tr1 to measure the input reflection coefficient S_{11} . The trace is the active trace in channel 4.

```
CALC4:PAR:SDEF 'Ch4Tr2', 'S22'
```

Create another trace named Ch4Tr2 to measure the output reflection coefficient S_{22} . Again this new trace becomes the active trace in channel 4.

```
CALC4:PAR:SEL 'Ch4Tr1'
```

Select the first trace Ch4Tr1 as the active trace.

```
CALC4:FORM MLIN
```

Calculate the magnitude of S_{11} and display it in a linearly scaled Cartesian diagram.

8.3.1.14 CALCulate:PHOLd...

The [CALCulate:PHOLd...](#) commands control the max hold (peak hold) function.

CALCulate<Chn>:PHOLd <HoldFunc>

Enables, disables, or restarts the max hold and the min hold functions.

Suffix:

<Chn> Channel number used to identify the active trace

Parameters:

<HoldFunc> MIN | MAX | OFF
 MIN - Enable the min hold function.
 MAX - enable the max hold function.
 OFF - disable the max hold or min hold function.
 *RST: OFF

Example:

```
*RST; :CALC:PHOL MAX
Reset the instrument and enable the max hold function.
CALC:PHOL OFF; PHOL MAX
Restart max hold.
```

Manual operation: See "[Hold](#)" on page 294

8.3.1.15 CALCulate:RIPPlE...

The CALCulate:RIPPlE... commands define the ripple limits and control the ripple limit check.

CALCulate:RIPPlE:DISPlay:RESult:ALL[:STATe].....	701
CALCulate:RIPPlE:FAIL:ALL?.....	702
CALCulate<Chn>:RIPPlE:CLEar.....	702
CALCulate<Chn>:RIPPlE:CONTRol:DOMain.....	702
CALCulate<Chn>:RIPPlE:DATA.....	703
CALCulate<Chn>:RIPPlE:DELeTe:ALL.....	704
CALCulate<Chn>:RIPPlE:DISPlay[:STATe].....	704
CALCulate<Chn>:RIPPlE:FAIL?.....	704
CALCulate<Chn>:RIPPlE:RDOMain:FORMat.....	705
CALCulate<Chn>:RIPPlE:SEGMENT:COUNT?.....	705
CALCulate<Chn>:RIPPlE:SEGMENT<Seg>[:STATe].....	706
CALCulate<Chn>:RIPPlE:SEGMENT<Seg>:LIMit.....	706
CALCulate<Chn>:RIPPlE:SEGMENT<Seg>:RESult?.....	707
CALCulate<Chn>:RIPPlE:SEGMENT<Seg>:STIMulus:START.....	708
CALCulate<Chn>:RIPPlE:SEGMENT<Seg>:STIMulus:STOP.....	708
CALCulate<Chn>:RIPPlE:SOUND[:STATe].....	708
CALCulate<Chn>:RIPPlE:STATe.....	709
CALCulate<Chn>:RIPPlE:STATe:AREA.....	709

CALCulate:RIPPlE:DISPlay:RESult:ALL[:STATe] <Enable>

Configures the display of ripple check info fields for the active recall set.

Parameters:

<Enable> ON - Info fields are displayed for all traces, for which a limit check is enabled.
 OFF - Only the info field for the active trace is displayed (if the ripple check is enabled for this trace).
 *RST: OFF

Manual operation: See "[Show Results All Traces](#)" on page 315

CALCulate:RIPple:FAIL:ALL? [<RecallSet>]

Returns a 0 or 1 to indicate whether or not the global ripple limit check has failed for at least one channel in the referenced recall set.

Query parameters:

<RecallSet> Recall set name; if omitted the active recall set is used

Usage: Query only

Manual operation: See "[Ripple Check](#)" on page 314

CALCulate<Chn>:RIPple:CLEar

Resets the limit check results for the ripple test.

Suffix:

<Chn> Channel number used to identify the active trace

Usage: Event

Manual operation: See "[Clear Test](#)" on page 315

CALCulate<Chn>:RIPple:CONTRol:DOMain <SweepType>

Deletes the existing ripple limit ranges and (re-)defines the physical units of the stimulus values of the ripple limit lines. The unit of the ripple limit is defined via [CALCulate<Chn>:RIPple:RDOMain:FORMat](#).

Suffix:

<Chn> Channel number used to identify the active trace

Setting parameters:

<SweepType> FLIN | FLOG | FSEG | FSINGle | TLIN | TLOG | PLIN | PLOG | PSINGle

Keywords for the units of the stimulus values; frequency, power, and time units.

The selected unit must be compatible with the sweep type (see [\[SENSe<Ch>:\]SWEep:TYPE](#) on page 988): Hz for FLIN, FLOG, FSEG and FSINGle, s for TLIN and TLOG, dBm for PLIN, PLOG and PSINGle. Otherwise the ripple limit lines cannot be displayed and no ripple limit check is possible.

*RST: FLIN

Example:

```
SWE:TYPE POW
```

Select a power sweep.

```
CALC:RIPP:CONT:DOM PLIN
```

Delete all existing ripple limit ranges and select level units for the domain of the active trace.

```
CALC:RIPP:DATA 1, -10, -5, 3
```

Define and enable a ripple limit range in the stimulus range between -10 dBm and -5 dBm, assigning a ripple limit of 3 dB.

Usage: Setting only

Manual operation: See "Add / Insert / Delete / Delete All / Align All" on page 317

CALCulate<Chn>:RIPple:DATA <RippleLimRange>...

Adds and enables/disables an arbitrary number of ripple limit ranges, assigning the stimulus values and the ripple limits. See [Chapter 5.4.1.2, "Rules for Ripple Test Definition"](#), on page 125.

Note: This command does not overwrite existing ripple limit ranges. The defined ranges are appended to the range list as new ranges. Use the `CALCulate<Chn>:RIPple:SEGment<Seg>...` commands to change existing ripple limits.

Suffix:

<Chn> Channel number used to identify the active trace

Parameters:

<RippleLimRange> Parameter list in the format <Type>, <StartStimulus>, <StopStimulus>, <RippleLimit>[, {<Type>, <StartStimulus>, <StopStimulus>, <RippleLimit>}], where:

- <Type> – Boolean identifier for the ripple limit range type. 1 for ripple limit range on (with limit check). 0 for ripple limit range off: The range is defined, but no limit check result displayed. The result is still available via `CALCulate<Chn>:RIPple:SEGment<Seg>:RESult?`.
- <StartStimulus>/<StopStimulus>– stimulus values (unitless) confining the ripple limit range
- <RippleLimit> – ripple limit (unitless) in the stimulus range between <StartStimulus> and <StopStimulus>

The unit of a stimulus value is adjusted to the sweep type of the active channel (`[SENSe<Ch>:]SWEep:TYPE`), the unit of a ripple limit is adjusted to the format of the active trace (`CALCulate<Chn>:FORMat`).

Range: Virtually no restriction for ripple limit ranges.
 *RST: n/a (no ripple limit line defined after a reset)

Example:

```
*RST; CALC:RIPP:DATA 1, 1500000000, 2000000000,
3, 1, 2000000000, 3000000000, 5
```

Define and enable a ripple limit range in the stimulus range between 1.5 GHz and 2 GHz, assigning a ripple limit of +3 dB. Define and enable a second ripple limit range in the stimulus range between 2 GHz and 3 GHz, assigning a ripple limit of +5 dB.

```
CALC:RIPP:DISP ON
```

Show the ripple limits in the active diagram.

Manual operation: See "Add / Insert / Delete / Delete All / Align All" on page 317

CALCulate<Chn>:RIPple:DElete:ALL

Deletes all ripple limit ranges.

Suffix:

<Chn> Channel number used to identify the active trace

Example:

```
*RST; CALC:RIPP:DATA 1,1500000000, 2000000000,
3, 1, 2000000000, 3000000000, 5
```

Define and enable a ripple limit range in the stimulus range between 1.5 GHz and 2 GHz, assigning a ripple limit of +3 dB. Define and enable a second ripple limit range in the stimulus range between 2 GHz and 3 GHz, assigning a ripple limit of +5 dB.

```
CALC:RIPP:DEL:ALL
```

Delete both created ripple limit ranges.

Usage:

Event

Manual operation: See ["Add / Insert / Delete / Delete All / Align All"](#) on page 317

CALCulate<Chn>:RIPple:DISPlay[:STATe] <Boolean>

Displays or hides all ripple limit lines (including all ranges) associated to the active trace.

Suffix:

<Chn> Channel number used to identify the active trace

Parameters:

<Boolean> ON | OFF - ripple limit line on or off.

```
*RST: OFF
```

Example:

```
*RST; CALC:RIPP:DATA 1,1500000000, 2000000000,
3
```

Define and enable a ripple limit range in the stimulus range between 1.5 GHz and 2 GHz, assigning a ripple limit of +3 dB.

```
CALC:RIPP:DISP ON
```

Show the ripple limit range in the active diagram.

Manual operation: See ["Show Ripple Limits"](#) on page 313

CALCulate<Chn>:RIPple:FAIL?

Returns a 0 or 1 to indicate whether or not the global ripple limit check has failed.

Tip: Use [CALCulate<Chn>:RIPple:SEGment<Seg>:RESult?](#) to query the result for a single ripple limit range.

Suffix:

<Chn> Channel number used to identify the active trace

- Example:** `*RST; CALC:RIPP:DATA 1, 1500000000, 2000000000, 3`
 Define and enable a ripple limit range in the stimulus range between 1.5 GHz and 2 GHz, assigning a ripple limit of +3 dB.
`CALC:RIPP:STAT ON; FAIL?`
 Switch the limit check on and query the result.
`CALC:RIPP:STAT:AREA LEFT, TOP`
 For a subsequent check at the GUI or a hardcopy, move the info field to the top left position.
- Usage:** Query only
- Manual operation:** See "[Ripple Check](#)" on page 314

CALCulate<Chn>:RIPple:RDOMain:FORMat <UnitRef>

Deletes the existing ripple limit ranges and (re-)defines the physical unit of the ripple limit. The units of the stimulus values are defined via `CALCulate<Chn>:RIPple:CONTrol:DOMain`.

Suffix:

<Chn> Channel number used to identify the active trace

Setting parameters:

<UnitRef> COMPlEx | MAGNitude | PHASe | REAL | IMAGinary | SWR | GDELay | L | C
 Keyword for the physical unit of the response values; dimensionless numererss, relative power, phase, time, inductance, capacitance units.

*RST: n/a
 Default unit: 1 (U, for COMPlEx, REAL, IMAGinary, and SWR); dB (for MAGNitude), deg (for PHASe), s (for GDELay), H (Henry, for L), F (Farad, for C).

- Example:** `*RST; CALC:RIPP:DATA 1, 1500000000, 2000000000, 3`
 Define and enable a ripple limit range in the stimulus range between 1.5 GHz and 2 GHz, assigning a ripple limit of +3 dB.
`CALC:RIPP:RDOM:FORM COMP`
 Delete the ripple limit range, select complex units for the ripple limit.

Usage: Setting only

CALCulate<Chn>:RIPple:SEGment:COUNT?

Queries the number of ripple limit ranges. The response is an integer number.

Suffix:

<Chn> Channel number used to identify the active trace

Example: `*RST; CALC:RIPP:DATA 1, 1500000000, 2000000000, 3, 1, 2000000000, 3000000000, 5`
 Define and enable a ripple limit range in the stimulus range between 1.5 GHz and 2 GHz, assigning a ripple limit of +3 dB. Define and enable a second ripple limit range in the stimulus range between 2 GHz and 3 GHz, assigning a ripple limit of +5 dB.
`CALC:RIPP:SEGM:COUNT?`
 Query the number of ranges. The response is 2.

Usage: Query only

Manual operation: See "[Range List](#)" on page 316

CALCulate<Chn>:RIPple:SEGment<Seg>[:STATe] <Boolean>

Enables or disables the limit check in the ripple limit range no. <Seg>.

Suffix:

<Chn> Channel number used to identify the active trace

<Seg> Number of the ripple limit range.

Parameters:

<Boolean> ON | OFF - Limit check on or off. A result is available even if the limit check is disabled; see example for `CALCulate<Chn>:RIPple:SEGment<Seg>:RESult?`.

*RST: n/a (no ripple limit line defined after a reset)

Example: See `CALCulate<Chn>:RIPple:SEGment<Seg>:STIMulus:START`

Manual operation: See "[Range List](#)" on page 316

CALCulate<Chn>:RIPple:SEGment<Seg>:LIMit <Limit>

Defines the ripple limit for ripple limit range no. <Seg>. A range must be created first to enable this command (e.g. `CALCulate<Chn>:RIPple:DATA`). See [Chapter 5.4.1.2, "Rules for Ripple Test Definition"](#), on page 125.

Tip: To define several ripple limit ranges with a single command, use `CALCulate<Chn>:RIPple:DATA`.

Suffix:

<Chn> Channel number used to identify the active trace

<Seg> Number of the ripple limit range.

Parameters:

<Limit> Ripple limit in the range. The unit is adjusted to the format of the active trace (`CALCulate<Chn>:FORMat`).

Range: Virtually no restriction for ripple limit ranges.
 *RST: n/a (no ripple limit line defined after a reset)
 Default unit: See above.

Example:

See `CALCulate<Chn>:RIPPlE:SEGment<Seg>:STIMulus:START`

Manual operation: See "Range List" on page 316

CALCulate<Chn>:RIPPlE:SEGment<Seg>:RESult?

Returns the result of the ripple limit check in the previously defined limit range no. <Seg>. The response consists of two parameters:

- <Boolean> – 0 for "passed", 1 for "failed".
- <Limit> – measured ripple in the limit range. A result is returned even if the limit check in the range no. <Seg> is disabled; see example below.

A reset deletes all ripple limit ranges. Use `CALCulate<Ch>:RIPPlE:FAIL?` to query the result for global ripple limit check.

Note: In remote control, the ripple limit check result is calculated once at the end of each sweep. If the ripple limits are changed, a new sweep is required to obtain updated ripple limit check results. In single sweep mode (`INITiate<Ch>:CONTinuous OFF`), the new sweep must be started explicitly. This behavior is different from manual control where a changed ripple limit line can directly affect the pass/fail result of the displayed trace.

Suffix:

<Chn> Channel number used to identify the active trace

<Seg> Number of the ripple limit range.

Example:

```
*RST; CALC:RIPP:DATA 1, 1500000000, 2000000000, 3
```

Define and enable a ripple limit range in the stimulus range between 1.5 GHz and 2 GHz, assigning a ripple limit of +3 dB.
`CALC:RIPP:STAT ON; SEGM:RES?`

Enable the limit check and query the result for the created range. Possible response: `0,0.3529814004`.

```
CALC:RIPP:DATA 0, 2500000000, 3000000000, 3
```

Define a second ripple limit range with disabled limit check (no limit check results are displayed in the diagram area).

```
CALC:RIPP:SEGM2:RES?
```

Query the result for the second range. Possible response: `0,1.149071925`.

Usage:

Query only

Manual operation: See "Ripple Check" on page 314

CALCulate<Chn>:RIPple:SEGment<Seg>:STIMulus:STARt <FreqPowTime>
CALCulate<Chn>:RIPple:SEGment<Seg>:STIMulus:STOP <StimValue>

These commands change the start or stop stimulus values (i.e. the smallest or largest stimulus values) of a ripple limit range. A range must be created first to enable these commands (e.g `CALCulate<Chn>:RIPple:DATA`). See [Chapter 5.4.1.2, "Rules for Ripple Test Definition"](#), on page 125.

Tip: To define several ripple limit ranges with a single command, use `CALCulate<Chn>:RIPple:DATA`.

Suffix:

<Chn> Channel number used to identify the active trace
 <Seg> Number of the ripple limit range.

Parameters:

<StimValue> Stimulus values (unitless) confining the ripple limit range. The unit is adjusted to the sweep type of the active channel (`[SENSe<Ch>:]SWEep:TYPE`).

Range: Virtually no restriction for ripple limit ranges.
 *RST: n/a (no ripple limit line defined after a reset)
 Default unit: NN

Example:

```
*RST; CALC:RIPP:DATA 1,1500000000, 2000000000,3
Define and enable a ripple limit range in the stimulus range
between 1.5 GHz and 2 GHz, assigning a ripple limit of +3 dB.
CALC:RIPP:SEGM:STIM:STAR 1GHZ; STOP 2.5 GHZ; :
CALC:RIPP:SEGM:LIM 5
Change the range to a stimulus range between 1 GHz and 2.5
GHz and a limit of 5 dB.
CALC:RIPP:SEGM:STAT OFF
Disable the limit check in the modified stimulus range.
```

Manual operation: See ["Range List"](#) on page 316

CALCulate<Chn>:RIPple:SOUNd[:STATe] <Boolean>

Switches the acoustic signal (fail beep) on or off. The fail beep is generated each time the analyzer detects an exceeded ripple limit.

Suffix:

<Chn> Channel number used to identify the active trace

Parameters:

<Boolean> ON | OFF - fail beep on or off.
 *RST: OFF

Example:

```
CALC:RIPP:STAT ON; SOUN ON
Switch the limit check on and activate the fail beep.
```

Manual operation: See ["Ripple Fail Beep"](#) on page 315

CALCulate<Chn>:RIPple:STATe <Boolean>

Switches the ripple limit check for the active trace on or off.

Tip: Use `CALCulate<Chn>:RIPple:SEGment<Seg>[:STATe]` to switch the limit check for a single ripple limit range on or off.

Suffix:

<Chn> Channel number used to identify the active trace

Parameters:

<Boolean> ON | OFF – ripple limit check on or off.
*RST: OFF

Example: See `CALCulate<Chn>:RIPple:FAIL?`

Manual operation: See "Ripple Check" on page 314

CALCulate<Chn>:RIPple:STATe:AREA <HorizontalPos>, <VerticalPos>

Moves the ripple test info field for the active trace <Chn> to one of nine predefined positions in the active diagram.

Suffix:

<Chn> Channel number used to identify the active trace

Parameters:

<HorizontalPos> LEFT | MID | RIGHT
Horizontal position
<VerticalPos> TOP | MID | BOTTom
Vertical position

Example: See `CALCulate<Chn>:RIPple:FAIL?`

Manual operation: See "Ripple Check" on page 314

8.3.1.16 CALCulate:PIPelining...

Commands related to [Pipelining of Measurement Data](#).

CALCulate:PIPelining:DATA? [<DutId>]

Queries the availability of channel results (to be queried, e.g., using `CALCulate<Chn>:DATA`) in *single-sweep* mode.

The string result '`<true|false>,<channel nos>`' indicates:

- `false`, if the sweep is still running
- `true`, if the sweep has been completed
- The comma-separated list of `channels nos` for which new measurement data are available (since the last call of `CALC:PIP:DATA?`)

Channels measured in *continuous* mode are not considered, and not returned.

Note:

- Because this query blocks the parser thread and the GUI thread until measurement data is available, a `timeout error -365` is returned after 10 seconds wait time.
- If no more data are available, the query returns an `execution error -200`

Query parameters:

<DutId> Not supported yet

Example:

```
// Set up measurements on channels 1 to 4
// Channels 1, 3, and 4:
// - single-sweep mode (INIT<Ch>:CONT OFF)
// - sweep count 1 (SWE:COUN:ALL 1)
// - alternated driving mode (SENS<Ch>:COUP NONE)
// Channel 2: continuous mode (INIT<Ch>:CONT ON).
INIT:PIPe:STAT ON //enable pipelining
INIT:IMM:ALL // start a new single sweep sequence
CALC:PIP:DATA? // assume a query result 'false, 1'
// --> sweep still running, data available for channel 1
// Query data using CALC1:DATA?
CALC:PIP:DATA? // assume a query result 'true, 3,4'
// --> sweep completed, data available for channels 3 and 4
// Query data using CALC3:DATA? and CALC4:DATA?
CALC:PIP:DATA?
-200,"Execution error;;CALCulate1:PIPe:DATA?"
```

Usage: Query only

Manual operation: See "[Pipelining](#)" on page 373

8.3.1.17 CALCulate:SMOothing...

The `CALCulate:SMOothing...` commands provide the settings for trace smoothing.

[CALCulate<Chn>:SMOothing\[:STATe\]](#).....710
[CALCulate<Chn>:SMOothing:APERture](#).....711

CALCulate<Chn>:SMOothing[:STATe] <Boolean>

Enables or disables smoothing for trace no. <Chn>.

Suffix:

<Chn> Channel number used to identify the active trace

Parameters:

<Boolean> ON | OFF - smoothing on or off.
 *RST: OFF

Example: See [CALCulate<Chn>:SMOothing:APERture](#)

Manual operation: See "[Smoothing](#)" on page 293

CALCulate<Chn>:SMOothing:APERture <SmoothAperture>

Defines how many measurement points are averaged to smooth the trace.

Suffix:

<Chn> Channel number used to identify the active trace

Parameters:

<SmoothAperture> Smoothing aperture. A smoothing aperture of n % means that the smoothing interval for each sweep point i with stimulus value x_i is equal to $[x_i - \text{span} \cdot n/200, x_i + \text{span} \cdot n/200]$, and that the result of i is replaced by the arithmetic mean value of all measurement points in this interval.

Range: 0.05% to 100%.

*RST: 1

Default unit: %

Example:

```
*RST; :CALC:SMO ON
```

Activate smoothing for the default trace.

```
CALC:SMO:APER 0.5
```

Reduce the smoothing aperture to 0.5 %.

Manual operation: See "[Aperture](#)" on page 293

8.3.1.18 CALCulate:STATistics...

The `CALCulate:STATistics...` commands evaluate and display statistical and phase information of the trace.

<code>CALCulate<Chn>:STATistics[:STATe]</code>	712
<code>CALCulate<Chn>:STATistics[:STATe]:AREA</code>	712
<code>CALCulate<Chn>:STATistics:DOMain:USER</code>	713
<code>CALCulate<Chn>:STATistics:DOMain:USER:SHOW</code>	713
<code>CALCulate<Chn>:STATistics:DOMain:USER:START</code>	713
<code>CALCulate<Chn>:STATistics:DOMain:USER:STOP</code>	713
<code>CALCulate<Chn>:STATistics:EPDelay[:STATe]</code>	714
<code>CALCulate<Chn>:STATistics:MMPTpeak[:STATe]</code>	714
<code>CALCulate<Chn>:STATistics:MSTDdev[:STATe]</code>	714
<code>CALCulate<Chn>:STATistics:FORMat</code>	714
<code>CALCulate<Chn>:STATistics:NLINear:COMP:LEVel</code>	715
<code>CALCulate<Chn>:STATistics:NLINear:COMP:PHAsE</code>	715
<code>CALCulate<Chn>:STATistics:NLINear:COMP:RDOMain:USER</code>	715
<code>CALCulate<Chn>:STATistics:NLINear:COMP:RDOMain:USER:SHOW</code>	716
<code>CALCulate<Chn>:STATistics:NLINear:COMP:RDOMain:USER:START</code>	716
<code>CALCulate<Chn>:STATistics:NLINear:COMP:RDOMain:USER:STOP</code>	716
<code>CALCulate<Chn>:STATistics:NLINear:COMP:REFerence</code>	716
<code>CALCulate<Chn>:STATistics:NLINear:COMP:RESult?</code>	717
<code>CALCulate<Chn>:STATistics:NLINear:COMP:RLEVel</code>	718
<code>CALCulate<Chn>:STATistics:NLINear:COMP:RMARker</code>	718
<code>CALCulate<Chn>:STATistics:NLINear:COMP:RPHase</code>	718
<code>CALCulate<Chn>:STATistics:NLINear:COMP:RPHase</code>	719
<code>CALCulate<Chn>:STATistics:NLINear:COMP[:STATe]</code>	719

CALCulate<Chn>:STATistics:RESult?.....	719
CALCulate<Chn>:STATistics:RMS[:STATe].....	720
CALCulate<Chn>:STATistics:SFLatness[:STATe].....	720

CALCulate<Chn>:STATistics[:STATe] <Boolean>

Displays or hides all statistical results in the diagram area of trace no. <Chn> except the compression point results.

Tip: You can display or hide the "Min/Max/Peak-Peak", "Mean/Std Dev/RMS", "Phase/EI Length" and "Flatness/Gain/Slope" results separately; see example below.

Suffix:

<Chn> Channel number used to identify the active trace

Parameters:

<Boolean> ON | OFF - Statistical info field on or off.

*RST: OFF

Example:

```
*RST; :CALC:STAT:MMPT ON
```

Reset the instrument, hiding all statistical results. Display the "Min/Max/Peak-Peak" results.

```
CALC:STAT:MSTD ON
```

Display the "Mean/Std Dev" results in addition.

```
CALC:STAT:RMS ON
```

Display the "RMS" results in addition.

```
CALC:STAT:EPD ON
```

Display the "Phase/EI Length" results in addition.

```
CALC:STAT:SFL ON
```

Display the "Flatness/Gain/Slope" results in addition.

```
CALC:STAT:STAT:AREA LEFT, TOP
```

For a subsequent check at the GUI or a hardcopy, move the info field to the top left position.

...

```
CALC:STAT OFF
```

Hide all results.

Manual operation: See ["Min/Max/Peak-Peak, Mean/Std Dev/RMS"](#) on page 286

CALCulate<Chn>:STATistics[:STATe]:AREA <HorizontalPos>, <VerticalPos>

Moves the statistics info field for the active trace <Chn> to one of nine predefined positions in the active diagram.

Suffix:

<Chn> Channel number used to identify the active trace

Parameters:

<HorizontalPos> LEFT | MID | RIGHT

Horizontal position

<VerticalPos> TOP | MID | BOTTOm

Vertical position

Example: See `CALCulate<Chn>:STATistics[:STATe]`

Manual operation: See "[Min/Max/Peak-Peak, Mean/Std Dev/RMS](#)" on page 286

`CALCulate<Chn>:STATistics:DOMain:USER <EvalRange>`

Selects one out of 10 evaluation ranges to be configured with the `CALCulate<Chn>:STATistics:DOMain:USER:SHOW`, `CALCulate<Chn>:STATistics:DOMain:USER:START`, and `CALCulate<Chn>:STATistics:DOMain:USER:STOP` commands.

Suffix:

<Chn> Channel number used to identify the active trace

Parameters:

<EvalRange> Number of the evaluation range.

Range: 1 to 10. In addition, 0 denotes the (non-configurable) "Full Span" evaluation range.

*RST: 0

Example:

*RST; :CALC:STAT:DOM:USER?

Query the default evaluation range. The response is zero, i.e. the evaluation range is equal to the complete sweep range

```
CALC:STAT:DOM:USER 1
```

```
CALC:STAT:DOM:USER:START 1GHZ; STOP 2GHZ; SHOW ON
```

Select evaluation range no. 1 and define the evaluation range between 1 GHz and 2 GHz. Display the range limit lines.

Manual operation: See "[Evaluation Range](#)" on page 291

`CALCulate<Chn>:STATistics:DOMain:USER:SHOW <Boolean>`

Displays or hides range limit lines for the evaluation range selected via `CALCulate<Chn>:STATistics:DOMain:USER`.

Suffix:

<Chn> Channel number used to identify the active trace

Parameters:

<Boolean> ON | OFF - range limit lines on or off.

*RST: OFF

Example:

See `CALCulate<Chn>:STATistics:DOMain:USER`

Manual operation: See "[Range Limit Lines On](#)" on page 292

`CALCulate<Chn>:STATistics:DOMain:USER:START <Start>`

`CALCulate<Chn>:STATistics:DOMain:USER:STOP <Stop>`

These commands define the start and stop values of the evaluation range selected via `CALCulate<Chn>:STATistics:DOMain:USER`.

Suffix:
 <Chn> Channel number used to identify the active trace

Parameters:
 <Stop> Start or stop value of the evaluation range.
 Default unit: NN

Example: See [CALCulate<Chn>:STATistics:DOMain:USER](#)

Manual operation: See "[Evaluation Range](#)" on page 291

CALCulate<Chn>:STATistics:EPDelay[:STATe] <Boolean>
CALCulate<Chn>:STATistics:MMPTpeak[:STATe] <Boolean>
CALCulate<Chn>:STATistics:MSTDdev[:STATe] <Boolean>

These commands display or hide the "Phase/EI Length" results, the "Min/Max/Peak-Peak" results, and the "Mean/Std Dev" results in the diagram area of trace no. <Chn>.

Suffix:
 <Chn> Channel number used to identify the active trace

Parameters:
 <Boolean> ON | OFF - statistical info field on or off.
 *RST: OFF

Example: See [CALCulate<Chn>:STATistics\[:STATe\]](#)

Manual operation: See "[Min/Max/Peak-Peak, Mean/Std Dev/RMS](#)" on page 286

CALCulate<Chn>:STATistics:FORMat <Format>

For complex-valued traces (Smith, Polar) this determines how the MEAN, STDDev, MAX, MIN, RMS and PTPeak statistics are calculated, see [CALCulate<Chn>:STATistics:RESult?](#).

Suffix:
 <Chn> Channel number used to identify the active trace

Parameters:
 <Format> ZVAB | IMPedance | ADMittance

ZVAB
 The results are based on unformatted wave quantities (voltages)

IMPedance
 The results are based on resistance values

ADMittance
 The results are based on conductance vaules

Manual operation: See "[Format](#)" on page 287

CALCulate<Chn>:STATistics:NLINear:COMP:LEVel <dBValue>

Defines the compression value x for the compression point measurement for dB formatted traces.

Use `CALCulate<Chn>:STATistics:NLINear:COMP:RESult?` to retrieve the compression results.

Suffix:

<Chn> Channel number used to identify the active trace

Parameters:

dBValue Compression value

Example:

See `CALCulate<Chn>:STATistics:NLINear:COMP:RESult?`

Manual operation: See "Compr. Point / Compr. Val." on page 289

CALCulate<Chn>:STATistics:NLINear:COMP:PHASe <PhaseValue>

Defines the compression value x for the compression point measurement for phase formatted traces.

Use `CALCulate<Chn>:STATistics:NLINear:COMP:RESult?` to retrieve the compression results.

Suffix:

<Chn> Channel number used to identify the active trace

Parameters:

<PhaseValue> Compression value

Default unit: deg

Manual operation: See "Compr. Point / Compr. Val." on page 289

CALCulate<Chn>:STATistics:NLINear:COMP:RDOMain:USER <RefRange>

Selects one of the 10 channel-specific user defined ranges as the reference range for compression point calculation.

Only applies if `CALCulate<Chn>:STATistics:NLINear:COMP:REFerence` is set to `RANGE`.

The selected range can then be configured with the `CALCulate<Chn>:STATistics:NLINear:COMP:RDOMain:USER:START`, `CALCulate<Chn>:STATistics:NLINear:COMP:RDOMain:USER:STOP`, and `CALCulate<Chn>:STATistics:NLINear:COMP:RDOMain:USER:SHOW` commands.

Suffix:

<Chn> Channel number used to identify the active trace

Parameters:

<RefRange> Range number
 Range: 1 to 10. In addition, 0 denotes the (non-configurable) "Full Span" evaluation range.
 *RST: 0

Manual operation: See "Ref. Range" on page 290

CALCulate<Chn>:STATistics:NLINear:COMP:RDOMain:USER:SHOW <Boolean>

Displays or hides range limit lines for the reference range selected via [CALCulate<Chn>:STATistics:NLINear:COMP:RDOMain:USER](#).

Suffix:

<Chn> Channel number used to identify the active trace

Parameters:

<Boolean> ON | OFF – reference range limit lines on or off.
 *RST: OFF

Manual operation: See "Ref. Range" on page 290

CALCulate<Chn>:STATistics:NLINear:COMP:RDOMain:USER:START <Start>

CALCulate<Chn>:STATistics:NLINear:COMP:RDOMain:USER:STOP <Value>

Defines the start/stop value of the range selected via [CALCulate<Chn>:STATistics:NLINear:COMP:RDOMain:USER](#).

Suffix:

<Chn> Channel number used to identify the active trace

Parameters:

<Value> Start/stop value of the related range

Manual operation: See "Ref. Range" on page 290

CALCulate<Chn>:STATistics:NLINear:COMP:REFerence <ReferenceValue>

Defines how the reference value ("small signal value") for the compression point calculation is calculated.

Suffix:

<Chn> Channel number used to identify the active trace

Parameters:

<ReferenceValue> FPOint | DVALue | MARKer | RANGE

FPOint – uses the value at the first point of the selected evaluation range as the reference value (see [CALCulate<Chn>:STATistics:DOMain:USER](#))

DVALue – allows to specify the reference value manually (see `CALCulate<Chn>:STATistics:NLINear:COMP:RLEVel` and `CALCulate<Chn>:STATistics:NLINear:COMP:RPHase`)

MARKer: uses the value at a selectable marker as the reference value (see `CALCulate<Chn>:STATistics:NLINear:COMP:RMARKer`)

RANGe – uses the average value in a configurable reference range as the reference value (see `CALCulate<Chn>:STATistics:NLINear:COMP:RDOMain:USER`)

*RST: FPOint

Manual operation: See "[Reference Value](#)" on page 290

CALCulate<Chn>:STATistics:NLINear:COMP:RESult?

Returns the compression point of an S-parameter or ratio measured in a power sweep.

For dB formatted traces, the compression value x is set via `CALCulate<Chn>:STATistics:NLINear:COMP:LEVel`, for phase formatted traces it is set via `CALCulate<Chn>:STATistics:NLINear:COMP:PHase`.

The response contains two numeric values:

- <Cmp In> – stimulus level at the compression point in dBm.
- <Cmp Out>
 - For dB formatted traces, the sum of <Cmp In> plus the magnitude of the measured response value at the compression point in dBm.
 - For phase formatted traces, the response value at the compression point

Suffix:

<Chn> Channel number used to identify the active trace

Example:

```
*RST; SWE:TYPE POW
```

Select a power sweep with default CW frequency and sweep range.

```
CALC:STAT:NLIN:COMP:LEV 2
```

Define a compression value of 2 dB.

```
CALC:STAT:NLIN:COMP:RES?
```

Query the compression point results <Cmp In>, <Cmp Out>. An execution error message (error no. -200) is returned if no compression point is found.

```
CALC:STAT:NLIN:COMP ON
```

Display the compression point result in the diagram area.

Usage: Query only

Manual operation: See "[Compr. Point / Compr. Val.](#)" on page 289

CALCulate<Chn>:STATistics:NLINear:COMP:RLEVel <Level>

Manually defines the reference level for compression point calculation on dB formatted traces.

This only applies if `CALCulate<Chn>:STATistics:NLINear:COMP:REference` is set to `DVALue`. For phase formatted traces, the reference level can be set using `CALCulate<Chn>:STATistics:NLINear:COMP:RPHase`.

Suffix:

<Chn> Channel number used to identify the active trace

Parameters:

<Level> Reference level
 *RST: 1 dB
 Default unit: dB

Manual operation: See "[Defined Value](#)" on page 291

CALCulate<Chn>:STATistics:NLINear:COMP:RMARker <Marker>

Allows you to select the marker whose value shall be used as the reference ("small signal value") for the compression point calculation.

Only applies if `CALCulate<Chn>:STATistics:NLINear:COMP:REference` is set to `MARker`.

Suffix:

<Chn> Channel number used to identify the active trace

Parameters:

<Marker> Marker number
 If marker <Marker> is OFF for the related trace, the set command is silently ignored.

Manual operation: See "[Selected Marker](#)" on page 290

CALCulate<Chn>:STATistics:NLINear:COMP:RPHase <Phase>

Manually defines the reference phase for compression point calculation on phase formatted traces.

Only applies if `CALCulate<Chn>:STATistics:NLINear:COMP:REference` is set to `DVALue`.

For dB formatted traces, the reference level can be set using `CALCulate<Chn>:STATistics:NLINear:COMP:RLEVel`.

Suffix:

<Chn> Channel number used to identify the active trace

Parameters:

<Phase> Reference phase
 *RST: 1°
 Default unit: deg

Manual operation: See "[Defined Value](#)" on page 291

CALCulate<Chn>:STATistics:NLINear:COMP:RPHase <Phase>

Manually defines the reference phase for compression point calculation on phase formatted traces.

Only applies if [CALCulate<Chn>:STATistics:NLINear:COMP:REference](#) is set to DVALue.

For dB formatted traces, the reference level can be set using [CALCulate<Chn>:STATistics:NLINear:COMP:RLEVel](#).

Suffix:

<Chn> Channel number used to identify the active trace

Parameters:

<Phase> Reference phase
 *RST: 1°
 Default unit: deg

Manual operation: See "[Defined Value](#)" on page 291

CALCulate<Chn>:STATistics:NLINear:COMP[:STATE] <Boolean>

Displays or hides the compression point result in the diagram area channel <Chn>'s active trace..

Suffix:

<Chn> Channel number used to identify the active trace

Parameters:

<Boolean> ON | OFF - statistical info field on or off.
 *RST: OFF

Example: See [CALCulate<Chn>:STATistics:NLINear:COMP:RESult?](#)

Manual operation: See "[Compr. Point / Compr. Val.](#)" on page 289

CALCulate<Chn>:STATistics:RESult? <Result>

Returns a single statistical parameter of the trace no. <Chn> or all parameters. It is not necessary to display the info field ([CALCulate<Chn>:STATistics\[:STATE\]](#) ON) before using this command.

Suffix:

<Chn> Channel number used to identify the active trace

Query parameters:

<Result>

MEAN | STDDev | MAX | MIN | RMS | PTPeak | PEAK2p | ELENgth | PDElay | GAIN | SLOPe | FLATness | ALL

MEAN - return arithmetic mean value of all response values of the trace in the entire sweep range (or in the evaluation range defined in manual control).

STDDev - return standard deviation of all response values.

MAX - return the maximum of all response values.

MIN - return the minimum of all response values.

RMS - return the root mean square of all response values.

PTPeak - return the peak-to-peak value (MAX - MIN).

ELENgth - return the electrical length.

PDElay - return the phase delay.

GAIN - return the gain, i.e. the larger of two marker values.

SLOPe - return the slope (difference) between two marker values.

FLATness - return the flatness of the trace between two marker positions.

ALL - return all statistical values, observing the order used above.

The data is returned as a comma-separated list of real numbers.

The unit is the default unit of the measured parameter (see

[CALCulate<Ch>:PARAmeter:SDEFine](#)) but may also depend

on the trace format (see [CALCulate<Chn>:FORMat](#)). For complex

traces the statistical results MEAN, STDDev, MAX, MIN,

RMS and PTPeak are calculated in the selected format (see

[CALCulate<Chn>:STATistics:FORMat](#)).

Example:

```
*RST; :CALC:STAT:RES? MAX
```

Calculate and return the maximum of the default trace showing an S-parameter on a dB Mag scale.

```
:CALC:FORM POL; STAT:RES? MAX
```

Display the trace in a polar diagram and re-calculate the maximum. The result corresponds to the previous result but is converted to a unitless linear value.

Usage:

Query only

Manual operation: See "[Min/Max/Peak-Peak, Mean/Std Dev/RMS](#)" on page 286

CALCulate<Chn>:STATistics:RMS[:STATe] <Boolean>

CALCulate<Chn>:STATistics:SFLatness[:STATe] <Boolean>

These commands display or hide the "RMS" and the "Flatness/Gain/Slope" results in the diagram area of trace no. <Chn>.

Suffix:

<Chn> Channel number used to identify the active trace

Parameters:

<Boolean> ON | OFF - statistical info field on or off.
 *RST: OFF

Example: See `CALCulate<Chn>:STATistics[:STATe]`

Manual operation: See "Flatness/Gain/Slope" on page 288

8.3.1.19 CALCulate:TDVSwr...

CALCulate:TDVSwr[:STATe] <Boolean>

Enables/disables time domain site VSWR measurements.

Parameters:

<Boolean> ON | OFF – TD-VSWR on or off.
 *RST: OFF

Manual operation: See "TD-VSWR" on page 281

8.3.1.20 CALCulate:TRANSform...

The `CALCulate:TRANSform...` commands convert measured data from one representation to another and control the transformation into the time domain (see [Chapter 5.7.5, "Time Domain Analysis"](#), on page 193).

<code>CALCulate<Chn>:TRANSform:COMPLex</code>	721
<code>CALCulate<Chn>:TRANSform:IMPedance:RNORmal</code>	722
<code>CALCulate<Chn>:TRANSform:TIME[:TYPE]</code>	722
<code>CALCulate<Chn>:TRANSform:TIME:CENTer</code>	723
<code>CALCulate<Chn>:TRANSform:TIME:DCHebyshev</code>	724
<code>CALCulate<Chn>:TRANSform:TIME:LPASs</code>	724
<code>CALCulate<Chn>:TRANSform:TIME:LPASs:DCSParam</code>	724
<code>CALCulate<Chn>:TRANSform:TIME:LPASs:DCSParam:CONTinuous</code>	725
<code>CALCulate<Chn>:TRANSform:TIME:LPASs:DCSParam:EXTRapolate</code>	726
<code>CALCulate<Chn>:TRANSform:TIME:LPFRequency</code>	726
<code>CALCulate<Chn>:TRANSform:TIME:RESolution:EFACtor</code>	726
<code>CALCulate<Chn>:TRANSform:TIME:SPAN</code>	726
<code>CALCulate<Chn>:TRANSform:TIME:STARt</code>	727
<code>CALCulate<Chn>:TRANSform:TIME:STATe</code>	727
<code>CALCulate<Chn>:TRANSform:TIME:STIMulus</code>	728
<code>CALCulate<Chn>:TRANSform:TIME:STOP</code>	728
<code>CALCulate<Chn>:TRANSform:TIME:WINDow</code>	729
<code>CALCulate<Chn>:TRANSform:TIME:XAXis</code>	729

CALCulate<Chn>:TRANSform:COMPLex <Result>

Converts S-parameters into converted (matched-circuit) Y-parameters or Z-parameters and vice versa, assuming that port no. i is terminated with Z_{0i} so that the three parameter sets are equivalent and the following formulas apply:

$$Z_{ii} = Z_{0i} \frac{1 + S_{ii}}{1 - S_{ii}}$$

$$Z_{ij} = 2 \frac{\sqrt{Z_{0i} Z_{0j}}}{S_{ij}} - (Z_{0i} + Z_{0j}) \quad \text{for } i \neq j$$

$$Y_{ii} = 1/Z_{ij} = \frac{1}{Z_{0i}} \cdot \frac{1 - S_{ii}}{1 + S_{ii}}$$

$$Y_{ij} = 1/Z_{ij} = \frac{S_{ij}}{2\sqrt{Z_{0i} Z_{0j}} - S_{ij}(Z_{0i} + Z_{0j})} \quad \text{for } i \neq j$$

Suffix:

<Chn> Channel number used to identify the active trace

Parameters:

<Result> S | Y | Z
S-parameters, Y-parameters, Z-parameters

Example:

```
*RST; CALC:PAR:MEAS 'Trc1', 'Y-S22'
```

Select the converted admittance Y <-- S22 as measurement parameter of the default trace.

```
CALC:TRAN:COMP S
```

Convert the converted Y-parameter into an S-parameter.

CALCulate<Chn>:TRANSform:IMPedance:RNORmal <Model>

Selects the theory for the renormalization of port impedances. The selection has an impact on the conversion formulas for wave quantities and S-parameters.

Suffix:

<Chn> Channel number used to identify the active trace

Parameters:

<Model> TWAVes | PWAVes
TWAVes - travelling waves
PWAVes - power waves
*RST: TWAVes

Example: See [\[SENSe<Ch>:\] PORT<PhyPt>:ZREFerence](#)

Manual operation: See ["Renormalization According to Theory of"](#) on page 230

CALCulate<Chn>:TRANSform:TIME[:TYPE] <TransformType>

Selects the time domain transformation type.

Suffix:

<Chn> Channel number used to identify the active trace

Parameters:

<TransformType> BPASs | LPASs
 BPASs - band pass impulse (only impulse response; a step response `CALCulate<Chn>:TRANSform:TIME:STIMulus STEP` is automatically changed to impulse response)
 LPASs - low pass (impulse or step response, depending on `CALCulate<Chn>:TRANSform:TIME:STIMulus` setting)
 *RST: BPASs

Example:

```
*RST; :CALC:TRAN:TIME:STAT ON
```

Reset the instrument, activating a frequency sweep, and enable the time domain transformation for the default trace.

```
CALC:TRAN:TIME LPAS; TIME:STIM STEP
```

Select a low pass step transformation.

```
CALC:TRAN:TIME:LPAS KFST
```

Calculate a harmonic grid, keeping the stop frequency and the number of points.

Manual operation: See "[Type](#)" on page 280

CALCulate<Chn>:TRANSform:TIME:CENTer <CenterTime>

Defines the center time of the diagram in time domain.

Suffix:

<Chn> Channel number used to identify the active trace

Parameters:

<CenterTime> Center time of the diagram in time domain.
 Range: -99.9999999999 s to +99.9999999999 s
 Increment: 0.1 ns
 *RST: 1.5E-009 s
 Default unit: s

Example:

```
*RST; :CALC:TRAN:TIME:STAT ON
```

Reset the instrument, activating a frequency sweep, and enable the time domain transformation for the default trace.

```
CALC:TRAN:TIME:CENT 0; SPAN 5ns
```

Set the center time to 0 ns and the time span to 5 ns.

Manual operation: See "[Time Start / Time Stop / Time Center / Time Span](#)" on page 348

Note: If the x-axis is scaled in distance units (`CALCulate<Chn>:TRANSform:TIME:XAXis DISTance`), then the center value is entered in m; the range and default value changes accordingly.

CALCulate<Chn>:TRANSform:TIME:DCHebyshev <SidebandSup>

Sets the sideband suppression for the Dolph-Chebyshev window. The command is only available if a Dolph-Chebyshev window is active ([CALCulate<Chn>:TRANSform:TIME:WINDow DCHebyshev](#)).

Suffix:

<Chn> Channel number used to identify the active trace

Parameters:

<SidebandSup> Sideband suppression
 Range: 10 dB to 120 dB
 Increment: 10 dB
 *RST: 32 dB
 Default unit: dB

Example:

```
*RST; :CALC:TRAN:TIME:WIND DCH
```

Reset the instrument and select a Dolph-Chebyshev window for filtering the data in the frequency domain.

```
CALC:TRAN:TIME:DCH 25
```

Set the sideband suppression to 25 dB.

Manual operation: See "[Side Lobe Level](#)" on page 281

CALCulate<Chn>:TRANSform:TIME:LPASs <Algorithm>

Calculates the harmonic grid for low pass time domain transforms according to one of the three alternative algorithms.

Suffix:

<Chn> Channel number used to identify the active trace

Parameters:

<Algorithm> KFSTop | KDFrequency | KSDFrequency
 KFSTop - keep stop frequency and number of points
 KDFrequency - keep frequency gap and number of points
 KSDfrequency - keep stop frequency and approximate frequency gap

Example:

See [CALCulate<Chn>:TRANSform:TIME\[:TYPE\]](#)

Manual operation: See "[Set Harmonic Grid and Keep](#)" on page 282

CALCulate<Chn>:TRANSform:TIME:LPASs:DCSParm <DCValue>

Defines the DC value for low pass transforms. The command is enabled only if the sweep points are on a harmonic grid (to be set explicitly or using [CALCulate<Chn>:TRANSform:TIME:LPASs](#)).

Suffix:

<Chn> Channel number used to identify the active trace

Parameters:

<DCValue> DC value of the measured quantity

Range: Depending on the measured quantity (-1 to +1 for S-parameters)

*RST: 0

Example:

```
*RST; :CALC:TRAN:TIME:STAT ON
```

Reset the instrument, activating a frequency sweep with S_{21} as measured quantity, and enable the time domain transformation for the default trace.

```
CALC:TRAN:TIME LPAS; TIME:STIM STEP
```

Select a low pass step transformation.

```
CALC:TRAN:TIME:LPAS KFST
```

Calculate a harmonic grid, maintaining the stop frequency and the number of points.

```
CALC:TRAN:TIME:LPAS:DCSP 0.2
```

Set the DC value.

```
CALC:TRAN:TIME:LPAS:DCSP:EXTR; :CALC:TRAN:TIME:LPAS:DCSP?
```

Extrapolate the measured trace, overwrite the defined DC value, and query the new value.

```
CALC:TRAN:TIME:LPAS:DCSP:CONT ON
```

Switch over to continuous extrapolation (e.g. because you noticed a discrepancy between the manually entered DC value and the extrapolation and assume the extrapolation to be more trustworthy).

```
CALC:TRAN:TIME:RES:EFAC 3
```

Select a resolution enhancement factor of 3 in order to improve the resolution in time domain.

Manual operation: See ["DC Value"](#) on page 283

CALCulate<Chn>:TRANSform:TIME:LPASs:DCSPParam:CONTinuous <Boolean>

Determines whether continuous extrapolation for the DC value is enabled.

Suffix:

<Chn> Channel number used to identify the active trace

Parameters:

<Boolean> ON - continuous extrapolation enabled
OFF - continuous extrapolation disabled

*RST: OFF

Example: See [CALCulate<Chn>:TRANSform:TIME:LPASs:DCSPParam](#)

Manual operation: See ["DC Value"](#) on page 283

CALCulate<Chn>:TRANSform:TIME:LPASs:DCSParam:EXTRapolate

Extrapolates the measured trace towards $f = 0$ and overwrites the current DC value (`CALCulate<Chn>:TRANSform:TIME:LPASs:DCSParam`). The command is relevant for low pass time domain transforms.

Suffix:

<Chn> Channel number used to identify the active trace

Example:

See `CALCulate<Chn>:TRANSform:TIME:LPASs:DCSParam`

Usage:

Event

Manual operation: See "DC Value" on page 283

CALCulate<Chn>:TRANSform:TIME:LPFRequency

Calculates the harmonic grid for low pass time domain transforms, keeping the stop frequency and the number of points.

Tip: Use `CALCulate<Chn>:TRANSform:TIME:LPASs` if you wish to use one of the other algorithms for calculating the grid.

Suffix:

<Chn> Channel number used to identify the active trace

Example:

See `CALCulate<Chn>:TRANSform:TIME[:TYPE]`

Usage:

Event

Manual operation: See "DC Value" on page 283

CALCulate<Chn>:TRANSform:TIME:RESolution:EFACtor <REfactor>

Defines the resolution enhancement factor for the time domain transform.

Suffix:

<Chn> Channel number used to identify the active trace

Parameters:

<REfactor> Resolution enhancement factor.

Range: 1 to 10.

Increment: 0.1

*RST: 1 (no resolution enhancement)

Example:

See `CALCulate<Chn>:TRANSform:TIME:LPASs:DCSParam`

Manual operation: See "Resolution Enh." on page 281

**CALCulate<Chn>:TRANSform:TIME:SPAN **

Defines the time span of the diagram in time domain.

Suffix:

<Chn> Channel number used to identify the active trace

Parameters:

 Time span of the diagram in time domain.
 Range: 2E-012 s to 200 s.
 Increment: 0.1 ns
 *RST: 5E-009 s
 Default unit: s

Example: See `CALCulate<Chn>:TRANSform:TIME:CENTer`

Manual operation: See "Time Start / Time Stop / Time Center / Time Span" on page 348

Note: If the x-axis is scaled in distance units (`CALCulate<Chn>:TRANSform:TIME:XAXis DISTance`), then the span is entered in m; the range and default value changes accordingly.

CALCulate<Chn>:TRANSform:TIME:START <StartTime>

Defines the start time of the diagram in time domain.

Suffix:

<Chn> Channel number used to identify the active trace

Parameters:

<StartTime> Start time of the diagram.
 Range: -100 s to +99.999999999998 s.
 Increment: 0.1 ns
 *RST: -1E-009 s
 Default unit: s

Example: `*RST; :CALC:TRAN:TIME:STAT ON`
 Reset the instrument, activating a frequency sweep, and enable the time domain transformation for the default trace.
`CALC:TRAN:TIME:STAR 0; STOP 10 ns`
 Set the start time to 0 ns and the stop time to 10 ns.

Manual operation: See "Time Start / Time Stop / Time Center / Time Span" on page 348

Note: If the x-axis is scaled in distance units (`CALCulate<Chn>:TRANSform:TIME:XAXis DISTance`), then the start value is entered in m; the range and default value changes accordingly.

CALCulate<Chn>:TRANSform:TIME:STATe <Boolean>

Determines whether the time domain transformation for trace no. <Chn> is enabled.

Suffix:

<Chn> Channel number used to identify the active trace

Parameters:

<Boolean> ON - time domain representation active.
 OFF - frequency domain representation active.
 *RST: OFF

Example:

*RST; :CALC:TRAN:TIME:STAT?
 Reset the instrument, activating a frequency sweep, and query whether the default trace is displayed in the time domain. The response is 0.

Manual operation: See ["Time Domain"](#) on page 280

CALCulate<Chn>:TRANSform:TIME:STIMulus <Type>

Selects the type of stimulus to be simulated in the low pass transformation process.

Suffix:

<Chn> Channel number used to identify the active trace

Parameters:

<Type> IMPulse | STEP
 IMPulse - impulse response, in bandpass or lowpass mode.
 STEP - step response, only in lowpass mode (a bandpass mode setting `CALCulate<Chn>:TRANSform:TIME[:TYPE]` BPASS is automatically changed to lowpass).
 *RST: IMP

Example: See `CALCulate<Chn>:TRANSform:TIME[:TYPE]`

Manual operation: See ["Type"](#) on page 280

CALCulate<Chn>:TRANSform:TIME:STOP <StopTime>

Defines the stop time of the diagram in time domain.

Suffix:

<Chn> Channel number used to identify the active trace

Parameters:

<StopTime> Stop time of the diagram.
 Range: -99.9999999999998 s to +100 s.
 Increment: 0.1 ns
 *RST: +4E-009 s
 Default unit: s

Example: See `CALCulate<Chn>:TRANSform:TIME:START`

Manual operation: See ["Time Start / Time Stop / Time Center / Time Span"](#) on page 348

Note: If the x-axis is scaled in distance units (`CALCulate<Chn>:TRANSform:TIME:XAXis DISTance`), then the stop value is entered in m; the range and default value changes accordingly.

CALCulate<Chn>:TRANSform:TIME:WINDow <WindowType>

Selects the window type for filtering the data in the frequency domain prior to the time domain transformation.

Suffix:

<Chn> Channel number used to identify the active trace

Parameters:

<WindowType> RECT | HAMMing | HANNing | BOHMan | DCHebyshev
 RECT - no profiling (rectangle)
 HANN - normal profile (Hann)
 HAMMing - low first sidelobe (Hamming)
 BOHMan - steep falloff (Bohman)
 DCHebyshev - arbitrary sidelobes (Dolph-Chebyshev)
 *RST: HANN

Example: See [CALCulate<Chn>:TRANSform:TIME:DCHebyshev](#)

Manual operation: See "[Impulse Response](#)" on page 280

CALCulate<Chn>:TRANSform:TIME:XAXis <Unit>

Switches over between the x-axis scaling in time units or distance units.

Suffix:

<Chn> Channel number used to identify the active trace

Parameters:

<Unit> TIME | DISTance
 TIME - x-axis scaled in time units.
 DISTance - x-axis scaled in distance units (Distance = Time * c_0
 * Velocity Factor).

Example: *RST; :CALC:TRAN:TIME:STAT ON
 Reset the instrument, activating a frequency sweep, and enable the time domain transformation for the default trace.
 CALC:TRAN:TIME:XAX DIST
 Convert the x-axis scaling to distance units.

Manual operation: See "[Time / Distance](#)" on page 349

8.3.1.21 CALCulate:TRANSform:DTFault...

The `CALCulate:TRANSform:DTFault...` commands set up and control a distance to fault measurement (with option R&S ZND-K3).

CALCulate<Chn>:TRANSform:DTFault:DEFine	730
CALCulate<Chn>:TRANSform:DTFault:DELe	731
CALCulate<Chn>:TRANSform:DTFault:SELe	731
CALCulate<Chn>:TRANSform:DTFault:CENTer	731
CALCulate<Chn>:TRANSform:DTFault:SPAN	731

CALCulate<Chn>:TRANSform:DTFault:PEAK:COUNT?	732
CALCulate<Chn>:TRANSform:DTFault:PEAK:DATA<FaultNo>	732
CALCulate<Chn>:TRANSform:DTFault:PEAK:STATE	733
CALCulate<Chn>:TRANSform:DTFault:PEAK:THReshold	733
CALCulate<Chn>:TRANSform:DTFault:POINTS	734
CALCulate<Chn>:TRANSform:DTFault:START	734
CALCulate<Chn>:TRANSform:DTFault:STOP	734
CALCulate<Chn>:TRANSform:DTFault:STATE	735

CALCulate<Chn>:TRANSform:DTFault:DEFine <CblName>, <CblPermittivity>, <CblAtt1>, <CblFreq1>{, <CblAtt2>, <CblFreq2>}...

Defines a new user-defined cable type for Distance to Fault (DtF) measurements.

The cable's frequency-dependent attenuation is defined via attenuation/frequency pairs <CblAtt1>, <CblFreq1>, <CblAtt2>, <CblFreq2>, At least one pair has to be specified.

Suffix:

<Chn> Channel number
This suffix is ignored: cable types are defined for all channels.

Setting parameters:

<CblName> Name of the cable type.
Must be unique among all DtF cable types, with case insensitive match.

<CblPermittivity> Relative permittivity ϵ_r of the cable type.

<CblAtt[i]> Attenuation value i in the frequency-dependent attenuation table of the cable type.
Default unit: dB/m

<CblFreq[i]> Frequency i in the frequency-dependent attenuation table of the cable type.
Default unit: Hz

Example:

```
CALCulate:TRANSform:DTFault:DEFine 'My cable
type', 1.1, 0.01, 1GHz, 0.015, 2GHz, 0.012,
3GHz
```

Defines a new cable type "My cable type" with relative permittivity $\epsilon_r=1.1$ and the frequency-dependent attenuation given in the table below.

Usage: Setting only

Options: R&S ZND-K3

Manual operation: See "Add / Delete" on page 501

Table 8-5: Example: frequency-dependent attenuation table

[i]	Frequency	Attenuation
1	1 GHz	0.01 dB/m
2	2 GHz	0.015 dB/m
3	3 GHz	0.012 dB/m

CALCulate<Chn>:TRANSform:DTFault:DELeTe <DtfDeleteCable>

Deletes the user-defined cable type with the given name.

Suffix:

<Chn> Channel number
This suffix is ignored: cable types are defined for (and deleted from) all channels.

Setting parameters:

<DtfDeleteCable> Name of a user-defined cable type.

Example:

CALCulate:TRANSform:DTFault:DELeTe 'My cable type'
Deletes the user-defined cable type "My cable type".

Usage:

Setting only

Options:

R&S ZND-K3

Manual operation: See ["Add / Delete"](#) on page 501

CALCulate<Chn>:TRANSform:DTFault:SELeCt <DtfSelectCable>

Selects one of the available (predefined or user-defined) cable types for Distance to Fault measurements.

Suffix:

<Chn> Channel number used to identify the active trace.

Parameters:

<DtfSelectCable> Name of the cable type.

Example:

CALCulate1:TRANSform:DTFault:SELeCt '5088-HFLR'
Selects cable type "5088-HFLR".

Options:

R&S ZND-K3

Manual operation: See ["Cable Type..."](#) on page 498

CALCulate<Chn>:TRANSform:DTFault:CENTer <Center>**CALCulate<Chn>:TRANSform:DTFault:SPAN **

Defines the distance window of the Distance to Fault measurement using its center and span.

See also `CALCulate<Chn>:TRANSform:DTFault:START` and `CALCulate<Chn>:TRANSform:DTFault:STOP`.

Suffix:

<Chn> Channel number used to identify the active trace.

Parameters:

<Center>/ Center/span value.
Default unit: m

Example:

```
:CALCulate1:TRANSform:DTFault:CENter 2; SPAN 2
```

Defines the DtF distance window of the active trace of channel 1 via its center (2m) and span (2m).

Options:

R&S ZND-K3

Manual operation: See "[Start Distance / Stop Distance](#)" on page 496

CALCulate<Chn>:TRANSform:DTFault:PEAK:COUNT?

If the active trace of channel <Chn> is a Distance to Fault (DtF) trace and DtF limit checking is enabled, this query returns the number of DtF limit violations of this trace.

Use `CALCulate<Chn>:TRANSform:DTFault:PEAK:STATE` to enable DtF limit checking and `CALCulate<Chn>:TRANSform:DTFault:PEAK:THReshold` to set the fault limit.

Suffix:

<Chn> Channel number used to identify the active trace

Usage:

Query only

Options:

R&S ZND-K3

Manual operation: See "[Fault Table](#)" on page 502

CALCulate<Chn>:TRANSform:DTFault:PEAK:DATA<FaultNo>

If the active trace of channel <Chn> is a Distance to Fault (DtF) trace and DtF limit checking is enabled, this query returns the peak data of DtF limit violation <FaultNo>

<FaultNo> must be between 1 and `CALCulate<Chn>:TRANSform:DTFault:PEAK:COUNT?`. The peak data are returned as value pair *distance, response value*. Peaks are numbered according to their distance (fault no. 1 has the smallest distance).

Use `CALCulate<Chn>:TRANSform:DTFault:PEAK:STATE` to enable DtF limit checking and `CALCulate<Chn>:TRANSform:DTFault:PEAK:THReshold` to set the fault limit.

Suffix:

<Chn> Channel number used to identify the active trace

<FaultNo>

1 ... `CALCulate<Chn>:TRANSform:DTFault:PEAK:COUNT?`

- Example:** Suppose `CALCulate1:TRANSform:DTFault:PEAK:COUNT?` returns 3, then
`CALCulate1:TRANSform:DTFault:PEAK:DATA1; DATA2; DATA3`
returns the coordinates of the DtF limit violation peaks.
- Options:** R&S ZND-K3
- Manual operation:** See "[Fault Table](#)" on page 502

CALCulate<Chn>:TRANSform:DTFault:PEAK:STATE <DtFPeakState>

If the active trace of channel <Chn> is a Distance to Fault (DtF) trace, this command allows to enable/disable DtF limit checking.

- Suffix:**
<Chn> Channel number used to identify the active trace
- Parameters:**
<DtFPeakState> OFF|ON (0|1)
- Example:** `*RST; :CALCulate1:TRANSform:DTFault:STATE ON`
makes the active trace of channel 1 a DtF trace.
`CALCulate1:TRANSform:DTFault:PEAK:STATE ON`
enables DtF limit checking.
- Options:** R&S ZND-K3
- Manual operation:** See "[Fault Limit Check](#)" on page 499

CALCulate<Chn>:TRANSform:DTFault:PEAK:THReshold <PeakThreshold>

If the active trace of channel <Chn> is a Distance to Fault (DtF) trace, this command allows to set the fault limit for DtF limit checking.

Use `CALCulate<Chn>:TRANSform:DTFault:PEAK:STATE` to enable DtF limit checking.

- Suffix:**
<Chn> Channel number used to identify the active trace
- Parameters:**
<PeakThreshold> Fault limit
*`RST: -20 dB`
Default unit: dB
- Example:** `*RST; :CALCulate1:TRANSform:DTFault:STATE ON`
makes the active trace of channel 1 a DtF trace.
`CALCulate1:TRANSform:DTFault:PEAK:THReshold -30`
sets the DtF limit to -30 dB.
- Options:** R&S ZND-K3
- Manual operation:** See "[Fault Limit](#)" on page 499

CALCulate<Chn>:TRANSform:DTFault:POINTs

If the active trace of channel <Chn> is a Distance to Fault (DtF) trace, this command starts the "Auto Number of Points" calculation (see ["Auto Number of Points"](#) on page 497).

An execution error is raised, if the calculated number of points is higher than the maximum number of sweep points the firmware allows (100001). To avoid this, reduce the frequency span Δf (see [\[SENSe<Ch>:\]SWEep:POINTs](#) on page 985) and/or the stop frequency d_{stop} (see [CALCulate<Chn>:TRANSform:DTFault:STOP](#)) so that

$$2.6 \cdot d_{\text{stop}} \cdot \Delta f / (v \cdot c_0) \leq 100001 ,$$

where v denotes the velocity factor of the measured cable (see [CALCulate<Chn>:TRANSform:DTFault:SElect](#)).

Suffix:

<Chn> Channel number used to identify the active trace

Example:

```
*RST; :CALCulate1:TRANSform:DTFault:STATE ON
makes the active trace of channel 1 a DtF trace.
SENSe1:SWEep:POINTs?
returns the default number of sweep points (201).
:CALCulate1:TRANSform:DTFault:START 0; STOP 100
widens the DtF distance window to 100m.
CALCulate1:TRANSform:DTFault:POINTs
starts the "Auto Number of Points calculation". Now
SENSe1:SWEep:POINTs?
returns an increased number of sweep points.
```

Usage: Event

Options: R&S ZND-K3

Manual operation: See ["Auto Number of Points"](#) on page 497

CALCulate<Chn>:TRANSform:DTFault:START <Start>**CALCulate<Chn>:TRANSform:DTFault:STOP <Stop>**

Defines the window of the Distance to Fault measurement using its start and stop distance.

See also [CALCulate<Chn>:TRANSform:DTFault:CENTER](#) and [CALCulate<Chn>:TRANSform:DTFault:SPAN](#).

Suffix:

<Chn> Channel number used to identify the active trace

Parameters:

<Start>/<Stop> Start/stop distance.
Default unit: m

Example:

```
:CALCulate1:TRANSform:DTFault:START 1; STOP 3
Defines the DtF distance window of the active trace of channel 1
as [1m, 3m].
```

Options: R&S ZND-K3

Manual operation: See "[Start Distance / Stop Distance](#)" on page 496

CALCulate<Chn>:TRANSform:DTFault:STATe <DtfState>

If channel <Chn> is performing an unsegmented frequency sweep, this command allows to transform its active trace into a Distance to Fault (DtF) trace.

Suffix:

<Chn> Channel number used to identify the active trace

Parameters:

<DtfState> OFF|ON – DtF disabled|enabled

*RST: OFF

Example:

```
:CALCulate1:TRANSform:DTFault:STATe ON
turns the DtF representation of the active trace of channel 1 ON.
```

Options: R&S ZND-K3

Manual operation: See "[Distance to Fault](#)" on page 496

8.3.1.22 CALCulate:TRANSform:VNETworks...

The CALCulate:TRANSform:VNETworks... commands define and activate the circuit models for the different de-/embedding types. See [Chapter 5.6.2, "Embedding and Deembedding"](#), on page 179 .

The circuit models are addressed by predefined enum constants. Except for the FIM-Port model, that consists of a single snp file, the models and constants are different for the different de-/embedding types.

Table 8-6: Circuit models for single ended port embedding/deembedding

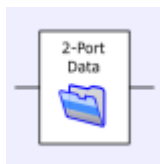
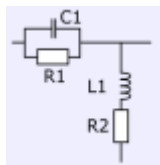
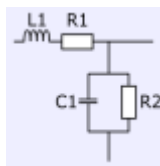
Parameter	Circuit model	Pictogram
FIMPort	File import, generic 2-port (no circuit model)	
CSL	Serial C, shunt L	
LSC	Serial L, shunt C	

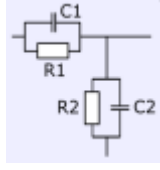
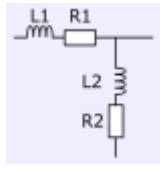
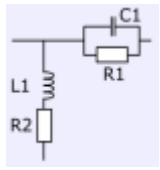
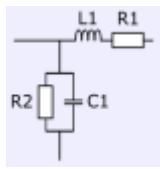
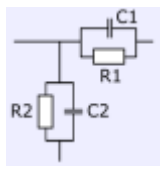
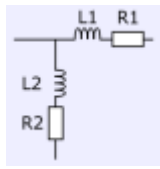
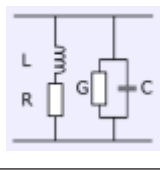
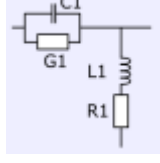
Parameter	Circuit model	Pictogram
CSC	Serial C, shunt C	
LSL	Serial L, shunt L	
SLC	Shunt L, serial C	
SCL	Shunt C, serial L	
SCC	Shunt C, serial C	
SLL	Shunt L, serial L	
SHLC	Shunt L, shunt C	
GSL	Serial C, shunt L	



Parameter	Circuit model	Pictogram
LSG	Serial L, shunt C	
GSG	Serial C, shunt C	
SGL	Shunt C, serial L	
SLG	Shunt L, serial C	
SGG	Shunt C, serial C	

Table 8-7: Circuit models for balanced port (and port pair) de-/embedding

Parameter	Circuit model	Pictogram
FIMPort	File import, generic 4-port (.s4p, no circuit model)	
STSL	Serial Touchstone (.s2p) data, shunt L	
STSC	Serial Touchstone (.s2p) data, shunt C	

Parameter	Circuit model	Pictogram
SLST	Shunt L, serial Touchstone (.s2p) data	
SCST	Shunt C, serial Touchstone (.s2p) data	
CSSL	Serial Cs, shunt L	
LSSC	Serial Ls, shunt C	
CSSC	Serial Cs, shunt C	
LSSL	Serial Ls, shunt L	
SLCS	Shunt L, serial Cs	
SCLS	Shunt C, serial Ls	

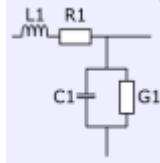
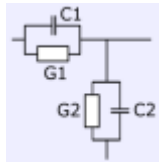
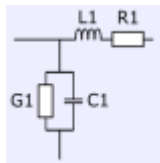
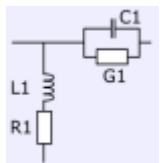
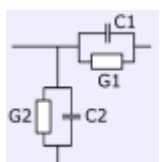
Parameter	Circuit model	Pictogram
SCCS	Shunt C, serial Cs	
SLLS	Shunt L, serial Ls	
STSG	Serial Touchstone (.s2p) data, shunt C	
SGST	Shunt C, serial Touchstone (.s2p) data	
GSSL	Serial Cs, shunt L	
LSSG	Serial Ls, shunt C	
GSSG	Serial Cs, shunt C	
SLGS	Shunt L, serial Cs	

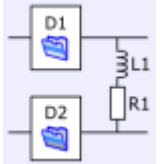
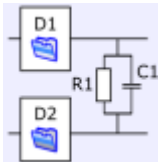
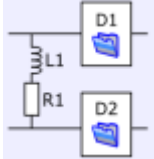
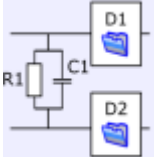
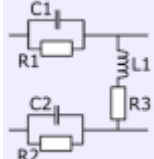
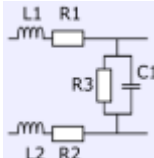
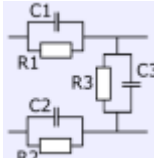
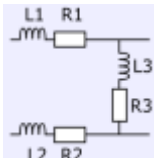
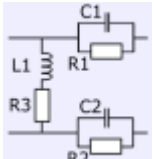
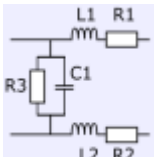
Parameter	Circuit model	Pictogram
SGLS	Shunt C, serial Ls	
SGGS	Shunt C, serial Cs	

Table 8-8: Circuit models for port set de-/embedding

Parameter	Circuit model	Pictogram
FIMPort	File import, no circuit model	
STSL, ..., SGGS	The models for port pairs (i.e. port sets with two ports) are the same as the ones for balanced ports See Table 8-7 .	

Table 8-9: Circuit models for ground loop de-/embedding

Parameter	Circuit model	Pictogram
FIMPort	File import, no circuit model	
SL	Shunt L	

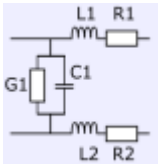
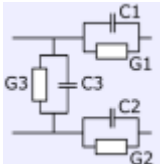

Parameter	Circuit model	Pictogram
SC	Shunt C	
SG	Shunt C	

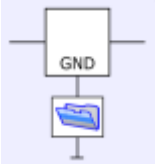
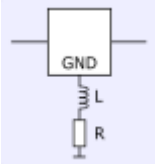
Table 8-10: Circuit models for differential match embedding

Parameter	Circuit model	Pictogram
FIMPort	File import, generic 2-port (no circuit model)	
SHLC	Shunt L, shunt C	

CALCulate<Ch>:TRANSform:VNETworks:BALanced:DEEMbedding<LogPt>[:STATE]..... 743

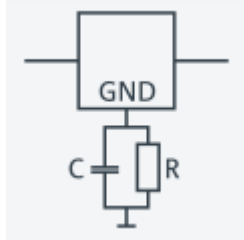
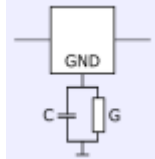
CALCulate<Ch>:TRANSform:VNETworks:BALanced:DEEMbedding<LogPt>:
 PARAmeters:C<Cmp>..... 744

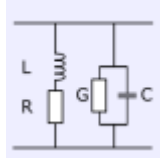
CALCulate<Ch>:TRANSform:VNETworks:BALanced:DEEMbedding<LogPt>:
 PARAmeters:DATA<Port>..... 745

CALCulate<Ch>:TRANSform:VNETworks:BALanced:DEEMbedding<LogPt>:
 PARAmeters:G<Cmp>..... 746

CALCulate<Ch>:TRANSform:VNETworks:BALanced:DEEMbedding<LogPt>:
 PARAmeters:L<Cmp>..... 746

CALCulate<Ch>:TRANSform:VNETworks:BALanced:DEEMbedding<LogPt>:
 PARAmeters:R<Cmp>..... 747

CALCulate<Ch>:TRANSform:VNETworks:BALanced:DEEMbedding<LogPt>:TNDefinition.... 748

CALCulate<Ch>:TRANSform:VNETworks:BALanced:EMBedding<LogPt>[:STATE]..... 748

CALCulate<Ch>:TRANSform:VNETworks:BALanced:EMBedding<LogPt>:PARAmeters:
 C<Cmp>..... 749

CALCulate<Ch>:TRANSform:VNETworks:BALanced:EMBedding<LogPt>:PARAmeters:
 DATA<Port>..... 750

CALCulate<Ch>:TRANSform:VNETworks:BALanced:EMBedding<LogPt>:PARAmeters:
 G<Cmp>..... 751

CALCulate<Ch>:TRANSform:VNETworks:BALanced:EMBedding<LogPt>:PARAmeters: L<Cmp>.....	751
CALCulate<Ch>:TRANSform:VNETworks:BALanced:EMBedding<LogPt>:PARAmeters: R<Cmp>.....	752
CALCulate<Ch>:TRANSform:VNETworks:BALanced:EMBedding<LogPt>:TNDefinition.....	753
CALCulate<Ch>:TRANSform:VNETworks:DIFFerential:EMBedding<LogPt>[:STATe].....	753
CALCulate<Ch>:TRANSform:VNETworks:DIFFerential:EMBedding<LogPt>: PARAmeters:C<Cmp>.....	754
CALCulate<Ch>:TRANSform:VNETworks:DIFFerential:EMBedding<LogPt>: PARAmeters:DATA.....	754
CALCulate<Ch>:TRANSform:VNETworks:DIFFerential:EMBedding<LogPt>: PARAmeters:G<Cmp>.....	755
CALCulate<Ch>:TRANSform:VNETworks:DIFFerential:EMBedding<LogPt>: PARAmeters:L<Cmp>.....	755
CALCulate<Ch>:TRANSform:VNETworks:DIFFerential:EMBedding<LogPt>: PARAmeters:R<Cmp>.....	756
CALCulate<Ch>:TRANSform:VNETworks:DIFFerential:EMBedding<LogPt>:TNDefinition.....	756
CALCulate<Ch>:TRANSform:VNETworks:GLOop:DEEMbedding[:STATe].....	756
CALCulate<Ch>:TRANSform:VNETworks:GLOop:DEEMbedding:PARAmeters:C.....	757
CALCulate<Ch>:TRANSform:VNETworks:GLOop:DEEMbedding:PARAmeters:G.....	757
CALCulate<Ch>:TRANSform:VNETworks:GLOop:DEEMbedding:PARAmeters:L.....	758
CALCulate<Ch>:TRANSform:VNETworks:GLOop:DEEMbedding:PARAmeters:R.....	759
CALCulate<Ch>:TRANSform:VNETworks:GLOop:DEEMbedding:TNDefinition.....	759
CALCulate<Ch>:TRANSform:VNETworks:GLOop:EMBedding[:STATe].....	760
CALCulate<Ch>:TRANSform:VNETworks:GLOop:EMBedding:PARAmeters:C.....	760
CALCulate<Ch>:TRANSform:VNETworks:GLOop:EMBedding:PARAmeters:G.....	761
CALCulate<Ch>:TRANSform:VNETworks:GLOop:EMBedding:PARAmeters:L.....	761
CALCulate<Ch>:TRANSform:VNETworks:GLOop:EMBedding:PARAmeters:R.....	762
CALCulate<Ch>:TRANSform:VNETworks:GLOop:EMBedding:TNDefinition.....	762
CALCulate<Ch>:TRANSform:VNETworks:GLOop:GROup.....	763
CALCulate<Ch>:TRANSform:VNETworks:FSIMulator[:STATe].....	763
CALCulate<Ch>:TRANSform:VNETworks:PPAir:DEEMbedding:DELeTe.....	763
CALCulate<Ch>:TRANSform:VNETworks:PPAir:DEEMbedding<ListId>[:STATe].....	763
CALCulate<Ch>:TRANSform:VNETworks:PPAir:DEEMbedding<ListId>:DEFine.....	764
CALCulate<Ch>:TRANSform:VNETworks:PPAir:DEEMbedding<ListId>:PARAmeters: C<1 2 3>.....	765
CALCulate<Ch>:TRANSform:VNETworks:PPAir:DEEMbedding<ListId>:PARAmeters: G<1 2 3>.....	765
CALCulate<Ch>:TRANSform:VNETworks:PPAir:DEEMbedding<ListId>:PARAmeters: L<1 2 3>.....	766
CALCulate<Ch>:TRANSform:VNETworks:PPAir:DEEMbedding<ListId>:PARAmeters: R<1 2 3>.....	767
CALCulate<Ch>:TRANSform:VNETworks:PPAir:DEEMbedding<ListId>:TNDefinition.....	767
CALCulate<Ch>:TRANSform:VNETworks:PPAir:EMBedding<ListId>[:STATe].....	768
CALCulate<Ch>:TRANSform:VNETworks:PPAir:EMBedding<ListId>:DEFine.....	768
CALCulate<Ch>:TRANSform:VNETworks:PPAir:EMBedding<ListId>:DELeTe.....	769
CALCulate<Ch>:TRANSform:VNETworks:PPAir:EMBedding<ListId>:PARAmeters:C<1 2 3>..	769
CALCulate<Ch>:TRANSform:VNETworks:PPAir:EMBedding<ListId>:PARAmeters:L<1 2 3>..	770
CALCulate<Ch>:TRANSform:VNETworks:PPAir:EMBedding<ListId>:PARAmeters:R<1 2 3>..	771
CALCulate<Ch>:TRANSform:VNETworks:PPAir:EMBedding<ListId>:PARAmeters:G<1 2 3>..	771

CALCulate<Ch>:TRANSform:VNETworks:PPAir:EMBedding<ListId>:TNDefinition.....	772
CALCulate<Ch>:TRANSform:VNETworks:PSET:DEEMbedding<ListId>:DEFine.....	773
CALCulate<Ch>:TRANSform:VNETworks:PSET:EMBedding<ListId>:DEFine.....	773
CALCulate<Ch>:TRANSform:VNETworks:SENDEd:DEEMbedding<PhyPt>[:STATe].....	773
CALCulate<Ch>:TRANSform:VNETworks:SENDEd:DEEMbedding<PhyPt>: PARAmeters:DATA.....	774
CALCulate<Ch>:TRANSform:VNETworks:SENDEd:DEEMbedding<PhyPt>: PARAmeters:C<Cmp>.....	774
CALCulate<Ch>:TRANSform:VNETworks:SENDEd:DEEMbedding<PhyPt>: PARAmeters:G<Cmp>.....	775
CALCulate<Ch>:TRANSform:VNETworks:SENDEd:DEEMbedding<PhyPt>: PARAmeters:L<Cmp>.....	776
CALCulate<Ch>:TRANSform:VNETworks:SENDEd:DEEMbedding<PhyPt>: PARAmeters:R<Cmp>.....	777
CALCulate<Ch>:TRANSform:VNETworks:SENDEd:DEEMbedding<PhyPt>:TNDefinition.....	777
CALCulate<Ch>:TRANSform:VNETworks:SENDEd:EMBedding<PhyPt>[:STATe].....	778
CALCulate<Ch>:TRANSform:VNETworks:SENDEd:EMBedding<PhyPt>:PARAmeters: DATA.....	778
CALCulate<Ch>:TRANSform:VNETworks:SENDEd:EMBedding<PhyPt>:PARAmeters: C<Cmp>.....	779
CALCulate<Ch>:TRANSform:VNETworks:SENDEd:EMBedding<PhyPt>:PARAmeters: G<Cmp>.....	780
CALCulate<Ch>:TRANSform:VNETworks:SENDEd:EMBedding<PhyPt>:PARAmeters: L<Cmp>.....	780
CALCulate<Ch>:TRANSform:VNETworks:SENDEd:EMBedding<PhyPt>:PARAmeters: R<Cmp>.....	781
CALCulate<Ch>:TRANSform:VNETworks:SENDEd:EMBedding<PhyPt>:TNDefinition.....	782
CALCulate<Ch>:TRANSform:VNETworks:WAVes.....	782

CALCulate<Ch>:TRANSform:VNETworks:BALanced:DEEMbedding<LogPt>[: STATe] <Boolean>

Enables or disables the deembedding function for balanced ports. It is allowed to change the circuit model and its parameters while deembedding is enabled.

Suffix:

<Ch>	Channel number
<LogPt>	Logical port number (balanced port)

Parameters:

<Boolean>	ON - deembedding active OFF - deembedding inactive
*RST:	OFF

Example: *RST; SOUR:LPOR1 1,2; LPOR2 3,4
 Define a balanced port configuration.
 CALC:TRAN:VNET:BAL:DEEM:TND CSSL
 Select the Serial Cs, shunt L circuit model for deembedding.
 CALC:TRAN:VNET:BAL:DEEM:PAR:R3 CSSL, 2.2E+3; :
 CALC:TRAN:VNET:BAL:DEEM ON
 Increase the resistance R3 for the Serial Cs, shunt L circuit
 model to 2.2 kΩ and enable deembedding.

Manual operation: See ["Active"](#) on page 440

**CALCulate<Ch>:TRANSform:VNETworks:BALanced:DEEMbedding<LogPt>:
 PARAmeters:C<Cmp> <CircuitModel>, <Capacitance>
 CALCulate<Ch>:TRANSform:VNETworks:BALanced:DEEMbedding<LogPt>:
 PARAmeters:C<Cmp>? <CircuitModel>**

Specifies the capacitance value C<Cmp> in the different circuit models for balanced port deembedding.

In the query form, the <Capacitance> parameter must be omitted. The command returns the capacitance value for the specified circuit model.

Suffix:

<Ch> Channel number
 <LogPt> Logical port number (balanced port)
 <Cmp> Number of capacitance in circuit model. The total number of
 capacitances depends on the selected circuit model.

Parameters:

<Capacitance> Capacitance C<Cmp> for the specified circuit model.
 Range: -1mF to 1 mF.
 Increment: 1 fF (1E-15 F)
 *RST: 1 pF (1E-12 F)
 Default unit: F

Parameters for setting and query:

<CircuitModel> STSC | SCST | CSSL | LSSC | CSSC | SLCS | SCLS | SCCS |
 STSG | SGST | GSSL | LSSG | GSSG | SLGS | SGLS | SGGS
 Possible circuit models (character data); see [Table 8-7](#).

Example: *RST; :SOUR:LPOR1 1,2; :CALC:TRAN:VNET:BAL:
 DEEM:PAR:C2? CSSL
 Create a balanced port and query the default capacitance C2 for
 the Serial Cs, shunt L circuit model. The response is 1E-012 (1
 pF).
 CALC:TRAN:VNET:BAL:DEEM:PAR:C2 CSSL, 2.2E-12
 Increase the capacitance to 2.2 pF.

Manual operation: See ["Network"](#) on page 471

**CALCulate<Ch>:TRANSform:VNETworks:BALanced:DEEMbedding<LogPt>:
PARAmeters:DATA<Port> <Interchange>, <arg1>**

Defines a deembedding network for a balanced port based on the given S-Parameter traces.

Circuit models `STSL` | `STSC` | `SLST` | `SCST` require S-Parameter traces of two 2-port networks, to be assigned to the different ports `PMAin` and `PSECondary`; the `FIMPort` model requires S-Parameter traces of a single 4-port network but no additional port assignment.

Use

- `CALCulate<Ch>:TRANSform:VNETworks:BALanced:DEEMbedding<LogPt>:TNDefinition` to select the adequate circuit model **before** executing this command.
- `MMEMory:LOAD:VNETworks<Ch>:BALanced:DEEMbedding<LogPt>` to load circuit data from a Touchstone file located at the R&S ZND's file system.

Suffix:

<Ch>	Channel number
<LogPt>	Logical port number
<Port>	Port assignment for two 2-port networks: 1 - Port 1 2 - Port 2 This parameter is ignored for 4-port networks.

Setting parameters:

<Interchange>	<code>FPORts</code> <code>IPORts</code> <code>SGATes</code> <code>SINCreasing</code> FPORts (or omitted) Standard port sequence (odd port numbers towards VNA, even port numbers towards DUT) IPORts – Two-port networks: inverted port sequence (network port 2 towards VNA, network port 1 towards DUT) – Four-port networks: increasing port sequence (low port numbers towards VNA, high port numbers towards DUT) SGATes Swapped gates (even port numbers towards VNA, odd port numbers towards DUT) SINCreasing Swapped increasing port sequence (high port numbers towards VNA, low port numbers towards DUT)
<arg1>	<block_data> Content of a Touchstone file (*.s2p or *.s4p) in IEEE488.2 Block Data Format .

Usage: Setting only

**CALCulate<Ch>:TRANSform:VNETworks:BALanced:DEEMbedding<LogPt>:
PARAMeters:G<Cmp>** <CircuitModel>, <Conductance>
**CALCulate<Ch>:TRANSform:VNETworks:BALanced:DEEMbedding<LogPt>:
PARAMeters:G<Cmp>?** <CircuitModel>

Specifies the conductance value G<Cmp> in the different circuit models for balanced port deembedding.

In the query form, the <Conductance> parameter must be omitted. The command returns the capacitance value for the specified circuit model.

Suffix:

<Ch>	Channel number
<LogPt>	Logical port number (balanced port)
<Cmp>	Number of conductance in circuit model. The total number of conductances depends on the selected circuit model.

Parameters:

<Conductance>	Conductance G<Cmp> for the specified circuit model. Range: -1kS to 1 kS. Increment: 1 nS (1E-9 S) *RST: 0 S Default unit: Siemens (SI unit symbol: S)
---------------	---

Parameters for setting and query:

<CircuitModel>	STSG SGST GSSL LSSG GSSG SLGS SGLS SGGS Possible circuit models (character data); see Table 8-7 .
----------------	--

Manual operation: See "[Network](#)" on page 471

**CALCulate<Ch>:TRANSform:VNETworks:BALanced:DEEMbedding<LogPt>:
PARAMeters:L<Cmp>** <CircuitModel>, <Inductance>
**CALCulate<Ch>:TRANSform:VNETworks:BALanced:DEEMbedding<LogPt>:
PARAMeters:L<Cmp>?** <CircuitModel>

Specifies the inductance value L<Cmp> in the different circuit models for balanced port deembedding.

In the query form, the <Inductance> parameter must be omitted. The command returns the inductance value for the specified circuit model.

Suffix:

<Ch>	Channel number
<LogPt>	Logical port number (balanced port)
<Cmp>	Number of inductance in circuit model. The total number of inductances depends on the selected circuit model.

Parameters:

<Inductance> Inductance L<Cmp> for the specified circuit model.
 Range: -1H to 1 H.
 Increment: 1 pH (1E-12 H)
 *RST: 1 nH (1E-9 H)
 Default unit: H

Parameters for setting and query:

<CircuitModel> STSL | SLST | CSSL | LSSC | LSSL | SLCS | SCLS | SLLS |
 GSSL | LSSG | SLGS | SGLS
 Possible circuit models (character data); see [Table 8-7](#).

Example:

```
*RST; :SOUR:LPOR1 1,2; :CALC:TRAN:VNET:BAL:
DEEM:PAR:L1? CSSL
Create a balanced port and query the default inductance L1 for
the Serial Cs, shunt L circuit model. The response is 1E-009 (1
nH).
CALC:TRAN:VNET:BAL:DEEM:PAR:L1 CSSL, 2.2E-9
Increase the inductance to 2.2 nH.
```

Manual operation: See "[Network](#)" on page 471

CALCulate<Ch>:TRANSform:VNETworks:BALanced:DEEMbedding<LogPt>:

PARAmeters:R<Cmp> <CircuitModel>, <Resistance>

CALCulate<Ch>:TRANSform:VNETworks:BALanced:DEEMbedding<LogPt>:

PARAmeters:R<Cmp>? <CircuitModel>

Specifies the resistance value R<Cmp> in the different circuit models for balanced port deembedding.

In the query form, the <Resistance> parameter must be omitted. The command returns the resistance value for the specified circuit model.

Suffix:

<Ch> Channel number
 <LogPt> Logical port number (balanced port)
 <Cmp> Number of resistance in circuit model. The total number of resistances depends on the selected circuit model.

Parameters:

<Resistance> Resistance R<Cmp> for the specified circuit model.
 Range: -10 MΩ to 10 MΩ.
 Increment: 1 mΩ (1E-3 Ω)
 *RST: 0 Ω for all resistances connected in series with an inductance. 10 MΩ for all resistances connected in parallel with a capacitance
 Default unit: Ω

Parameters for setting and query:

<CircuitModel> STSL | STSC | SLST | SCST | CSSL | LSSC | CSSC | LSSL |
SLCS | SCLS | SCCS | SLLS | GSSL | LSSG | SLGS | SGLS
Possible circuit models (character data); see [Table 8-7](#).

Example:

```
*RST; :SOUR:LPOR1 1,2; :CALC:TRAN:VNET:BAL:
DEEM:PAR:R1? CSSL; R2? CSSL; R3? CSSL
Create a balanced port and query the default resistances for the
Serial Cs, shunt L circuit model. The response is
10000000000;10000000000; 0.
CALC:TRAN:VNET:BAL:DEEM:PAR:R3 CSSL, 2.2E+3
Increase the resistance R3 to 2.2 kΩ.
```

Manual operation: See "[Network](#)" on page 471

**CALCulate<Ch>:TRANSform:VNETworks:BALanced:DEEMbedding<LogPt>:
TNDefinition <CircuitModel>**

Selects the circuit model for balanced port deembedding.

Suffix:

<Ch> Channel number
<LogPt> Logical port number (balanced port)

Parameters:

<CircuitModel> FIMPort | STSL | STSC | SLST | SCST | CSSL | LSSC | CSSC |
LSSL | SLCS | SCLS | SCCS | SLLS | STSG | SGST | GSSL |
LSSG | GSSG | SLGS | SGLS | SGGS
Possible circuit models (character data); see [Table 8-7](#).

```
*RST: CSSL
```

Example:

See [CALCulate<Ch>:TRANSform:VNETworks:BALanced:DEEMbedding<LogPt>\[:STATe\]](#)

Manual operation: See "[Network](#)" on page 471

**CALCulate<Ch>:TRANSform:VNETworks:BALanced:EMBedding<LogPt>[:STATe]
<Boolean>**

Enables or disables the embedding function for balanced ports. It is allowed to change the circuit model and its parameters while embedding is enabled.

Suffix:

<Ch> Channel number
<LogPt> Logical port number (balanced port)

Parameters:

<Boolean> ON | OFF - embedding active or inactive
*RST: OFF

Example: *RST; SOUR:LPOR1 1,2; LPOR2 3,4
 Define a balanced port configuration.
 CALC:TRAN:VNET:BAL:EMB:TND CSSL
 Select the Serial Cs, shunt L circuit model for embedding.
 CALC:TRAN:VNET:BAL:EMB:PAR:R3 CSSL, 2.2E+3; :
 CALC:TRAN:VNET:BAL:EMB ON
 Increase the resistance R3 for the Serial Cs, shunt L circuit
 model to 2.2 kΩ and enable embedding.

Manual operation: See ["Active"](#) on page 440

**CALCulate<Ch>:TRANSform:VNETworks:BALanced:EMBedding<LogPt>:
 PARAmeters:C<Cmp> <CircuitModel>, <Capacitance>
 CALCulate<Ch>:TRANSform:VNETworks:BALanced:EMBedding<LogPt>:
 PARAmeters:C<Cmp>? <CircuitModel>**

Specifies the capacitance value C<Cmp> in the different circuit models for balanced port embedding.

In the query form, the <Capacitance> parameter must be omitted. The command returns the capacitance value for the specified circuit model.

Suffix:

<Ch> Channel number
 <LogPt> Logical port number (balanced port)
 <Cmp> Number of capacitance in circuit model. The total number of capacitances depends on the selected circuit model.

Parameters:

<Capacitance> Capacitance C<Cmp> for the specified circuit model.
 Range: -1mF to 1 mF.
 Increment: 1 fF (1E-15 F)
 *RST: 1 pF (1E-12 F)
 Default unit: F

Parameters for setting and query:

<CircuitModel> STSC | SCST | CSSL | LSSC | CSSC | SLCS | SCLS | SCCS |
 STSG | SGST | GSSL | LSSG | GSSG | SLGS | SGLS | SGGS
 Possible circuit models (character data); see [Table 8-7](#).

Example: *RST; :SOUR:LPOR1 1,2; :CALC:TRAN:VNET:BAL:EMB:
 PAR:C2? CSSL
 Create a balanced port and query the default capacitance C2 for
 the Serial Cs, shunt L circuit model. The response is 1E-012 (1
 pF).
 CALC:TRAN:VNET:BAL:EMB:PAR:C2 CSSL, 2.2E-12
 Increase the capacitance to 2.2 pF.

Manual operation: See ["Network"](#) on page 471

**CALCulate<Ch>:TRANSform:VNETworks:BALanced:EMBedding<LogPt>:
PARAmeters:DATA<Port> <Interchange>, <arg1>**

Defines an embedding network for a balanced port based on the given S-Parameter traces.

Circuit models `STSL` | `STSC` | `SLST` | `SCST` require S-Parameter traces of two 2-port networks, to be assigned to the different ports; the `FIMPort` model requires S-Parameter traces of a single 4-port network but no additional port assignment.

Use

- `CALCulate<Ch>:TRANSform:VNETworks:BALanced:EMBedding<LogPt>:TNDefinition` to select the adequate circuit model **before** executing this command.
- `MMEMemory:LOAD:VNETworks<Ch>:BALanced:EMBedding<LogPt>` to load circuit data from a Touchstone file located at the R&S ZND's file system.

Suffix:

<Ch>	Channel number
<LogPt>	Logical port number
<Port>	Port assignment for two 2-port networks: 1 - Port 1 2 - Port 2 This parameter is ignored for 4-port networks.

Setting parameters:

<Interchange>	<code>FPORts</code> <code>IPORts</code> <code>SGATes</code> <code>SINCreasing</code> FPORts (or omitted) Standard port sequence (odd port numbers towards VNA, even port numbers towards DUT) IPORts – Two-port networks: inverted port sequence (network port 2 towards VNA, network port 1 towards DUT) – Four-port networks: increasing port sequence (low port numbers towards VNA, high port numbers towards DUT) SGATes Swapped gates (even port numbers towards VNA, odd port numbers towards DUT) SINCreasing Swapped increasing port sequence (high port numbers towards VNA, low port numbers towards DUT)
<arg1>	<block_data> Content of a Touchstone file (*.s2p or *.s4p) in IEEE488.2 Block Data Format .
Usage:	Setting only

**CALCulate<Ch>:TRANSform:VNETworks:BALanced:EMBedding<LogPt>:
PARAMeters:G<Cmp>** <CircuitModel>, <Conductance>
**CALCulate<Ch>:TRANSform:VNETworks:BALanced:EMBedding<LogPt>:
PARAMeters:G<Cmp>?** <CircuitModel>

Specifies the conductance value G<Cmp> in the different circuit models for balanced port embedding.

In the query form, the <Conductance> parameter must be omitted. The command returns the capacitance value for the specified circuit model.

Suffix:

<Ch>	Channel number
<LogPt>	Logical port number (balanced port)
<Cmp>	Number of conductance in circuit model. The total number of conductances depends on the selected circuit model.

Parameters:

<Conductance>	Conductance G<Cmp> for the specified circuit model. Range: -1kS to 1 kS. Increment: 1 pS (1E-12 S) *RST: 0 S Default unit: Siemens (SI unit symbol: S)
---------------	--

Parameters for setting and query:

<CircuitModel>	STSG SGST GSSL LSSG GSSG SLGS SGLS SGGS Possible circuit models (character data); see Table 8-7 .
----------------	--

Manual operation: See "[Network](#)" on page 471

**CALCulate<Ch>:TRANSform:VNETworks:BALanced:EMBedding<LogPt>:
PARAMeters:L<Cmp>** <CircuitModel>, <Inductance>
**CALCulate<Ch>:TRANSform:VNETworks:BALanced:EMBedding<LogPt>:
PARAMeters:L<Cmp>?** <CircuitModel>

Specifies the inductance values L1, L2, L3 in the different circuit models for balanced port embedding.

In the query form, the <Inductance> parameter must be omitted. The command returns the inductance value for the specified circuit model.

Suffix:

<Ch>	Channel number
<LogPt>	Logical port number (balanced port)
<Cmp>	Number of inductance in circuit model. The total number of inductances depends on the selected circuit model.

Parameters:

<Inductance> Inductance L<Cmp> for the specified circuit model.
 Range: -1H to 1 H.
 Increment: 1 pH (1E-12 H)
 *RST: 1 nH (1E-9 H)
 Default unit: H

Parameters for setting and query:

<CircuitModel> STSL | SLST | CSSL | LSSC | LSSL | SLCS | SCLS | SLLS |
 GSSL | LSSG | SLGS | SGLS
 Possible circuit models (character data); see [Table 8-7](#).

Example:

```
*RST; :SOUR:LPOR1 1,2; :CALC:TRAN:VNET:BAL:EMB:
PAR:L1? CSSL
Create a balanced port and query the default inductance L1 for
the Serial Cs, shunt L circuit model. The response is 1E-009 (1
nH).
CALC:TRAN:VNET:BAL:EMB:PAR:L1 CSSL, 2.2E-9
Increase the inductance to 2.2 nH.
```

Manual operation: See "[Network](#)" on page 471

CALCulate<Ch>:TRANSform:VNETworks:BALanced:EMBedding<LogPt>:

PARAmeters:R<Cmp> <CircuitModel>, <Resistance>

CALCulate<Ch>:TRANSform:VNETworks:BALanced:EMBedding<LogPt>:

PARAmeters:R<Cmp>? <CircuitModel>

Specifies the resistance values R1, R2, R3 in the different circuit models for balanced port embedding.

In the query form, the <Resistance> parameter must be omitted. The command returns the resistance value for the specified circuit model.

Suffix:

<Ch> Channel number
 <LogPt> Logical port number (balanced port)
 <Cmp> Number of resistance in circuit model. The total number of resistances depends on the selected circuit model.

Parameters:

<Resistance> Resistance R<Cmp> for the specified circuit model.
 Range: -10 MΩ to 10 MΩ.
 Increment: 1 mΩ (1E-3 Ω)
 *RST: 0 Ω for all resistances connected in series with an inductance. 10 MΩ for all resistances connected in parallel with a capacitance
 Default unit: Ω

Parameters for setting and query:

<CircuitModel> STSL | STSC | SLST | SCST | CSSL | LSSC | CSSC | LSSL |
SLCS | SCLS | SCCS | SLLS | GSSL | LSSG | SLGS | SGLS
Possible circuit models (character data); see [Table 8-7](#).

Example:

```
*RST; :SOUR:LPOR1 1,2; :CALC:TRAN:VNET:EMB:
PAR:R1? CSSL; R2? CSSL; R3? CSSL
Create a balanced port and query the default resistances for the
Serial Cs, shunt L circuit model. The response is
10000000000;10000000000; 0.
CALC:TRAN:VNET:EMB:PAR:R3 CSSL, 2.2E+3
Increase the resistance R3 to 2.2 kΩ.
```

Manual operation: See ["Network"](#) on page 471

**CALCulate<Ch>:TRANSform:VNETworks:BALanced:EMBedding<LogPt>:
TNDefinition <CircuitModel>**

Selects the circuit model for balanced port embedding.

Suffix:

<Ch> Channel number
<LogPt> Logical port number (balanced port)

Parameters:

<CircuitModel> FIMPort | STSL | STSC | SLST | SCST | CSSL | LSSC | CSSC |
LSSL | SLCS | SCLS | SCCS | SLLS | STSG | SGST | GSSL |
LSSG | GSSG | SLGS | SGLS | SGGS
Possible circuit models (character data); see [Table 8-7](#).
*RST: CSSL

Example:

See [CALCulate<Ch>:TRANSform:VNETworks:BALanced:
EMBedding<LogPt>\[:STATE\]](#)

Manual operation: See ["Network"](#) on page 471

**CALCulate<Ch>:TRANSform:VNETworks:DIFFerential:EMBedding<LogPt>[:
STATE] <Boolean>**

Enables or disables differential match embedding for balanced port <LogPt>.

Suffix:

<Ch> Channel number
<LogPt> Logical port number (balanced port)

Parameters:

<Boolean> ON | OFF - embedding active or inactive
*RST: OFF

Manual operation: See ["Active"](#) on page 442

**CALCulate<Ch>:TRANSform:VNETworks:DIFFerential:EMBedding<LogPt>:
PARAmeters:C<Cmp> <CircuitModel>[, <Capacitance>]**

Specifies the capacitance value C in the "Shunt L, Shunt C" lumped element model for differential match embedding.

In the query form, the <Capacitance> parameter must be omitted.

Suffix:

<Ch>	Channel number
<LogPt>	Logical port number (balanced port)
<Cmp>	Must be omitted or set to 1.

Parameters:

<CircuitModel>	SHLC Currently only the "Shunt L, Shunt C" lumped element model is supported
<Capacitance>	Range: -1mF to 1 mF. Increment: 1 fF (1E-15 F) *RST: 1 pF (1E-12 F) Default unit: F

Manual operation: See "[Network](#)" on page 475

**CALCulate<Ch>:TRANSform:VNETworks:DIFFerential:EMBedding<LogPt>:
PARAmeters:DATA <Interchange>, <SParamTrcs>**

Defines a [Differential Match Embedding](#) network for a balanced port based on the given S-Parameter traces.

Use `MMEMory:LOAD:VNETworks<Ch>:DIFFerential:EMBedding<LogPt>` to load circuit data from a Touchstone file located at the R&S ZND's file system instead.

Suffix:

<Ch>	Channel number
<LogPt>	Logical port number of a balanced port

Setting parameters:

<Interchange>	FPORts IPORts SGATes FPORts (or omitted) Standard port sequence (network port 1 towards VNA, network port 2 towards DUT) IPORts SGATes Inverted port sequence (network port 2 towards VNA, network port 1 towards DUT)
<SParamTrcs>	<block_data> Content of a two-port Touchstone file (* . s2p) in IEEE488.2 Block Data Format .

Usage: Setting only

**CALCulate<Ch>:TRANSform:VNETworks:DIFFerential:EMBedding<LogPt>:
PARAmeters:G<Cmp>** <CircuitModel>[, <Conductance>]

Specifies the conductance value G in the "Shunt L, Shunt C" lumped element model for differential match embedding.

In the query form, the <Conductance> parameter must be omitted.

Suffix:

<Ch>	Channel number
<LogPt>	Logical port number (balanced port)
<Cmp>	Must be omitted or set to 1.

Parameters:

<CircuitModel>	SHLC Currently only the "Shunt L, Shunt C" lumped element model is supported
<Conductance>	Range: -10 MS to 10 MS. Increment: 1 μ S (1E-6 F) *RST: 0 S Default unit: S(iemens)

Manual operation: See "[Network](#)" on page 475

**CALCulate<Ch>:TRANSform:VNETworks:DIFFerential:EMBedding<LogPt>:
PARAmeters:L<Cmp>** <CircuitModel>[, <Inductance>]

Specifies the inductance value L in the "Shunt L, Shunt C" lumped element model for differential match embedding.

In the query form, the <Inductance> parameter must be omitted.

Suffix:

<Ch>	Channel number
<LogPt>	Logical port number (balanced port)
<Cmp>	Must be omitted or set to 1

Parameters:

<CircuitModel>	SHLC Currently only the "Shunt L, Shunt C" lumped element model is supported
<Inductance>	Range: -1 H to 1 H Increment: 1 pH (1E-12 H) *RST: 1 nH (1E-9 H) Default unit: H

Manual operation: See "[Network](#)" on page 475

**CALCulate<Ch>:TRANSform:VNETworks:DIFFerential:EMBedding<LogPt>:
PARAmeters:R<Cmp> <CircuitModel>[, <Resistance>]**

Specifies the resistance value R in the "Shunt L, Shunt C" lumped element model for differential match embedding.

In the query form, the <Resistance> parameter must be omitted.

Suffix:

<Ch>	Channel number
<LogPt>	Logical port number (balanced port)
<Cmp>	Must be omitted or set to 1.

Parameters:

<CircuitModel>	SHLC Currently only the "Shunt L, Shunt C" lumped element model is supported
<Resistance>	Range: -10 MΩ to 10 MΩ. Increment: 1 mΩ (1E-3 Ω) *RST: 0 Ω Default unit: Ohm

Manual operation: See "[Network](#)" on page 475

**CALCulate<Ch>:TRANSform:VNETworks:DIFFerential:EMBedding<LogPt>:
TNDefinition <CircuitModel>**

Selects the circuit model for differential match embedding.

Suffix:

<Ch>	Channel number
<LogPt>	Logical port number (balanced port)

Parameters:

<CircuitModel>	FIMPort SHLC Possible circuit models (character data), see Circuit models for differential match embedding
----------------	---

Manual operation: See "[Network](#)" on page 475

**CALCulate<Ch>:TRANSform:VNETworks:GLOop:DEEMbedding[:STATe]
<Boolean>**

Enables or disables the deembedding function for ground loops. It is allowed to change the circuit model and its parameters while deembedding is enabled.

Suffix:

<Ch>	Channel number.
------	-----------------

Parameters:

<Boolean> ON - Deembedding active
 OFF - Deembedding inactive
 *RST: OFF

Example:

```
CALC:TRAN:VNET:GLO:DEEM:TND SL
Select the Shunt L circuit model for deembedding.
CALC:TRAN:VNET:GLO:DEEM:PAR:R SL, 2.2E+3; :
CALC:TRAN:VNET:GLO:DEEM ON
Increase the resistance for the Shunt L circuit model to 2.2 kΩ
and enable deembedding.
```

Manual operation: See "[Active](#)" on page 441

CALCulate<Ch>:TRANSform:VNETworks:GLOop:DEEMbedding:PARameters:C
 <CircuitModel>, <Capacitance>

CALCulate<Ch>:TRANSform:VNETworks:GLOop:DEEMbedding:PARameters:C?
 <CircuitModel>

Specifies the capacitance value C in the different circuit models for ground loop embedding.

Suffix:

<Ch> Channel number

Parameters:

<Capacitance> Capacitance C for ground loop deembedding.
 Range: -1mF to 1 mF.
 Increment: 1 fF (1E-15 F)
 *RST: 1 pF (1E-12 F)
 Default unit: F

Parameters for setting and query:

<CircuitModel> SC | SG

Possible circuit models (character data); see [Table 8-9](#).

Example:

```
*RST; :CALC:TRAN:VNET:GLO:DEEM:PAR:C? SC
Query the default capacitance for ground loop deembedding.
The response is 1E-012 (1 pF).
CALC:TRAN:VNET:GLO:DEEM:PAR:C SC, 2.2E-12
Increase the capacitance to 2.2 pF.
```

Manual operation: See "[Network](#)" on page 473

CALCulate<Ch>:TRANSform:VNETworks:GLOop:DEEMbedding:PARameters:G
 <CircuitModel>, <Conductance>

CALCulate<Ch>:TRANSform:VNETworks:GLOop:DEEMbedding:PARameters:G?
 <CircuitModel>

Specifies the conductance value G in the different circuit models for ground loop embedding.

Suffix:

<Ch> Channel number.

Parameters:

<Conductance> Conductance G for the specified circuit model.
 Range: -1kS to 1 kS.
 Increment: 1 nS (1E-9 S)
 *RST: 0 S
 Default unit: Siemens (SI unit symbol: S)

Parameters for setting and query:

<CircuitModel> SG
 Possible circuit models (character data); see [Table 8-9](#).

Manual operation: See "[Network](#)" on page 473

CALCulate<Ch>:TRANSform:VNETworks:GLOop:DEEMbedding:PARameters:L
 <CircuitModel>, <Inductance>

CALCulate<Ch>:TRANSform:VNETworks:GLOop:DEEMbedding:PARameters:L?
 <CircuitModel>

Specifies the inductance value in the different circuit models for ground loop deembedding.

Suffix:

<Ch> Channel number.

Parameters:

<Inductance> Inductance L for ground loop deembedding.
 Range: -1 H to 1 H.
 Increment: 1 pH (1E-12 H)
 *RST: 1 nH (1E-9 H)
 Default unit: H

Parameters for setting and query:

<CircuitModel> SL
 Possible circuit models (character data); see [Table 8-9](#).

Example:

```
*RST; :CALC:TRAN:VNET:GLO:DEEM:PAR:L? SL
Query the default inductance for ground loop deembedding. The
response is 1E-009 (1 nH).
CALC:TRAN:VNET:GLO:DEEM:PAR:L SL, 2.2E-9
Increase the inductance to 2.2 nH.
```

Manual operation: See "[Network](#)" on page 473

CALCulate<Ch>:TRANSform:VNETworks:GLOop:DEEMbedding:PARAmeters:R
<CircuitModel>, <Resistance>

CALCulate<Ch>:TRANSform:VNETworks:GLOop:DEEMbedding:PARAmeters:R?
<CircuitModel>

Specifies the resistance value R in the different circuit models for ground loop deem-
bedding.

Suffix:

<Ch> Channel number.

Parameters:

<Resistance> Resistance R for the specified circuit model.
Range: -10 MΩ to 10 MΩ
Increment: 1 mΩ
*RST: 0 Ω if the resistance is connected in series with an
inductance. 10 MΩ if the resistance is connected in
parallel with a capacitance)
Default unit: Ω

Parameters for setting and query:

<CircuitModel> SL | SC
Possible circuit models (character data); see [Table 8-9](#).

Example:

```
*RST; :CALC:TRAN:VNET:GLO:DEEM:PAR:R? SC; R? SL
Query the default resistances for ground loop deembedding. The
response is 10000000; 0.
CALC:TRAN:VNET:GLO:DEEM:PAR:R SC, 2.2E+3
Increase the resistance for the Shunt C model to 2.2 kΩ.
```

Manual operation: See "[Network](#)" on page 473

CALCulate<Ch>:TRANSform:VNETworks:GLOop:DEEMbedding:TNDefinition
<CircuitModel>

Selects the circuit model for ground loop deembedding.

Suffix:

<Ch> Channel number.

Parameters:

<CircuitModel> FIMPort | SL | SC | SG
Possible circuit models (character data); see [Circuit models for
ground loop de-/embedding](#).

Example:

```
See CALCulate<Ch>:TRANSform:VNETworks:GLOop:
DEEMbedding[:STATE] on page 756
```

Manual operation: See "[Network](#)" on page 473

CALCulate<Ch>:TRANSform:VNETworks:GLOop:EMBedding[:STATe] <Boolean>

Enables or disables the embedding function for ground loops. It is allowed to change the circuit model and its parameters while embedding is enabled.

Suffix:

<Ch> Channel number.

Parameters:

<Boolean> ON - Embedding active
OFF - Embedding inactive
*RST: OFF

Example:

```
CALC:TRAN:VNET:GLO:EMB:TND SL
Select the Shunt L circuit model for embedding.
CALC:TRAN:VNET:GLO:EMB:PAR:R SL, 2.2E+3; :CALC:
TRAN:VNET:GLO:EMB ON
Increase the resistance for the Shunt L circuit model to 2.2 kΩ
and enable embedding.
```

Manual operation: See ["Active"](#) on page 441

CALCulate<Ch>:TRANSform:VNETworks:GLOop:EMBedding:PARAmeters:C
<CircuitModel>, <Capacitance>**CALCulate<Ch>:TRANSform:VNETworks:GLOop:EMBedding:PARAmeters:C?**
<CircuitModel>

Specifies the capacitance value C in the different circuit models for ground loop embedding.

Suffix:

<Ch> Channel number.

Parameters:

<Capacitance> Capacitance C for ground loop embedding.
Range: -1mF to 1 mF.
Increment: 1 fF (1E-15 F)
*RST: 1 pF (1E-12 F)
Default unit: F

Parameters for setting and query:

<CircuitModel> SC | SG
Possible circuit models (character data); see [Table 8-9](#).

Example:

```
*RST; :CALC:TRAN:VNET:GLO:EMB:PAR:C? SC
Query the default capacitance for ground loop embedding. The
response is 1E-012 (1 pF).
CALC:TRAN:VNET:GLO:EMB:PAR:C SC, 2.2E-12
Increase the capacitance to 2.2 pF.
```

Manual operation: See ["Network"](#) on page 473

CALCulate<Ch>:TRANSform:VNETworks:GLOop:EMBedding:PARAmeters:G
 <CircuitModel>, <Conductance>

CALCulate<Ch>:TRANSform:VNETworks:GLOop:EMBedding:PARAmeters:G?
 <CircuitModel>

Specifies the conductance value G in the different circuit models for ground loop embedding.

Suffix:

<Ch> Channel number.

Parameters:

<Conductance> Conductance G for the specified circuit model.
 Range: -1kS to 1 kS.
 Increment: 1 pS (1E-12 S)
 *RST: 0 S
 Default unit: Siemens (SI unit symbol: S)

Parameters for setting and query:

<CircuitModel> SG
 Possible circuit models (character data); see [Table 8-9](#).

Manual operation: See "[Network](#)" on page 473

CALCulate<Ch>:TRANSform:VNETworks:GLOop:EMBedding:PARAmeters:L
 <CircuitModel>, <Inductance>

CALCulate<Ch>:TRANSform:VNETworks:GLOop:EMBedding:PARAmeters:L?
 <CircuitModel>

Specifies the inductance value in the different circuit models for ground loop embedding.

Suffix:

<Ch> Channel number.

Parameters:

<Inductance> Inductance L for ground loop embedding.
 Range: -1H to 1 H.
 Increment: 1 pH (1E-12 H)
 *RST: 1 nH (1E-9 H)
 Default unit: H

Parameters for setting and query:

<CircuitModel> SL
 Possible circuit models (character data); see [Table 8-9](#).

Example:

```
*RST; :CALC:TRAN:VNET:GLO:EMB:PAR:L? SL
Query the default inductance for ground loop embedding. The
response is 1E-009 (1 nH).
CALC:TRAN:VNET:GLO:EMB:PAR:L SL, 2.2E-9
Increase the inductance to 2.2 nH.
```

Manual operation: See "[Network](#)" on page 473

CALCulate<Ch>:TRANSform:VNETworks:GLOop:EMBedding:PARameters:R
<CircuitModel>, <Resistance>

CALCulate<Ch>:TRANSform:VNETworks:GLOop:EMBedding:PARameters:R?
<CircuitModel>

Specifies the resistance value R in the different circuit models for ground loop embedding.

Suffix:

<Ch> Channel number.

Parameters:

<Resistance> Resistance R for the specified circuit model.
 Range: -10 MΩ to 10 MΩ
 Increment: 1 mΩ
 *RST: 0 Ω if the resistance is connected in series with an inductance. 10 MΩ if the resistance is connected in parallel with a capacitance)
 Default unit: Ω

Parameters for setting and query:

<CircuitModel> SL | SC
 Possible circuit models (character data); see [Table 8-9](#).

Example:

```
*RST; :CALC:TRAN:VNET:GLO:EMB:PAR:R? SC; R? SL
Query the default resistances for ground loop embedding. The
response is 10000000; 0.
CALC:TRAN:VNET:GLO:EMB:PAR:R SC, 2.2E+3
Increase the resistance for the Shunt C model to 2.2 kΩ.
```

Manual operation: See "[Network](#)" on page 473

CALCulate<Ch>:TRANSform:VNETworks:GLOop:EMBedding:TNDefinition
<CircuitModel>

Selects the circuit model for ground loop embedding.

Suffix:

<Ch> Channel number.

Parameters:

<CircuitModel> FIMPort | SL | SC | SG
 Possible circuit models (character data); see [Circuit models for ground loop de-/embedding](#).
 *RST: FIMPort

Example:

```
See CALCulate<Ch>:TRANSform:VNETworks:GLOop:
EMBedding[:STATE] on page 760
```

Manual operation: See "[Network](#)" on page 473

CALCulate<Ch>:TRANSform:VNETworks:GLOop:GROup <Boolean>

If set to ON (1), each port group (defined using [SOURCE<Ch>:GROup<Grp>:PPORts](#)) has its own ground loop embedding and deembedding network. Otherwise the same embedding network and deembedding network is used for all active ports.

See the

[CALCulate<Ch>:TRANSform:VNETworks:GLOop:DEEMbedding<group>:...](#)
and [CALCulate<Ch>:TRANSform:VNETworks:GLOop:EMBedding<group>:...](#)
commands.

Suffix:

<Ch> Channel number

Parameters:

<Boolean> Range: ON (1) | OFF (0)
*RST: OFF (0)

CALCulate<Ch>:TRANSform:VNETworks:FSIMulator[:STATe] <Enable>

De/activates the "Fixture Simulator" switch that allows to disable and (re-)enable the configured deembedding, embedding, balanced ports, and port impedance settings for the selected channel.

Suffix:

<Ch> Channel number

Parameters:

<Enable>

Manual operation: See "[Fixture Simulator](#)" on page 429

CALCulate<Ch>:TRANSform:VNETworks:PPAir:DEEMbedding:DELeTe

Deletes all port sets (including port pairs) previously defined for deembedding.

Suffix:

<Ch> Channel number

Example:

See [CALCulate<Ch>:TRANSform:VNETworks:PPAir:DEEMbedding<ListId>\[:STATe\]](#)

Usage:

Event

Manual operation: See "[Add / Delete](#)" on page 438

CALCulate<Ch>:TRANSform:VNETworks:PPAir:DEEMbedding<ListId>[:STATe]
<arg0>

Enables or disables the deembedding function for port set (or port pair) <ListId>. It is allowed to change the deembedding network while embedding is enabled.

Suffix:

<Ch> Channel number

<ListId> Index of the affected port set

Parameters:

<arg0> **OFF** (0): Deembedding inactive
ON (1): Deembedding active
 *RST: OFF (0)

Example:

```
*RST; CALC:TRAN:VNET:PPA:DEEM:DEF 1,2,3,4
Define a port pair configuration with port pairs (1,2) and (3,4).
CALC:TRAN:VNET:PPA:DEEM1:TND CSSL
Select the Serial Cs, shunt L circuit model for the first port pair.
CALC:TRAN:VNET:PPA:DEEM1:PAR:
R3 CSSL, 2.2E+3; CALC:TRAN:VNET:PPA:DEEM1 ON
Increase the resistance R3 for the Serial Cs, shunt L circuit
model to 2.2 kΩ and enable deembedding.
CALC:TRAN:VNET:PPA:DEEM:DEL
Delete the port pair configuration.
```

Manual operation: See ["Active"](#) on page 439

CALCulate<Ch>:TRANSform:VNETworks:PPAir:DEEMbedding<ListId>:DEFine
 <PP_First>,<PP_Second>,<PP_First>,...

Creates one or more port pairs for port set deembedding. The command can be used repeatedly to extend or (partially) overwrite the list of port sets for deembedding.

See [CALCulate<Ch>:TRANSform:VNETworks:PSET:DEEMbedding<ListId>:DEFine](#) on page 773 for general port set definition.

Suffix:

<Ch> Channel number

<ListId> Index of the defined port set within the channel's overall list of port sets for deembedding.
 Port sets for deembedding must be numbered consecutively, i.e. port set <ListId> can only be created if port set <ListId>-1 already exists. If several port pairs are specified, <ListId> is the number of the first port pair to be created.

Parameters:

<PP_First>,
 <PP_Second>,
 <PP_First>, ... Sequence of port pairs, each one consisting of two different ports.

Example:

See [CALCulate<Ch>:TRANSform:VNETworks:PPAir:DEEMbedding<ListId>\[:STATE\]](#)

Usage: Setting only

Manual operation: See ["Add / Delete"](#) on page 438

**CALCulate<Ch>:TRANSform:VNETworks:PPAir:DEEMbedding<ListId>:
PARAMeters:C<1|2|3> <CircuitModel>, <Capacitance>**
**CALCulate<Ch>:TRANSform:VNETworks:PPAir:DEEMbedding<ListId>:
PARAMeters:C<1|2|3>? <CircuitModel>**

Specifies the capacitance value C<i> in the different lumped circuit models for port pair deembedding.

In the query form, the <Capacitance> parameter must be omitted. The command returns the capacitance value for the specified circuit model.

Suffix:

<Ch> Channel number

<ListId> Index of the affected port pair (see [CALCulate<Ch>:TRANSform:VNETworks:PPAir:DEEMbedding<ListId>:DEFine](#))

<1|2|3> Index i of the capacitance C<i> in the related lumped circuit model. If unspecified the numeric suffix is set to 1.

Parameters:

<Capacitance> Capacitance Ci
 Range: -1 mF to 1 mF
 Increment: 1 fF (1E-15 F)
 *RST: 1 pF (1E-12 F)
 Default unit: F

Parameters for setting and query:

<CircuitModel> STSC | SCST | CSSL | LSSC | CSSC | SLCS | SCLS | SCCS | STSG | SGST | GSSL | LSSG | GSSG | SLGS | SGLS | SGGS
 Circuit model whose capacitance C<i> shall be set, see [Table 8-7](#)

Example: See [CALCulate<Ch>:TRANSform:VNETworks:PPAir:DEEMbedding<ListId>\[:STATE\]](#)

Manual operation: See "[Network](#)" on page 468

**CALCulate<Ch>:TRANSform:VNETworks:PPAir:DEEMbedding<ListId>:
PARAMeters:G<1|2|3> <CircuitModel>, <Conductance>**
**CALCulate<Ch>:TRANSform:VNETworks:PPAir:DEEMbedding<ListId>:
PARAMeters:G<1|2|3>? <CircuitModel>**

Specifies the conductance value G<i> in the different lumped circuit models for port pair deembedding.

In the query form, the <Conductance> parameter must be omitted. The command returns the conductance value for the specified circuit model.

Suffix:

<Ch> Channel number

<ListId> Index of the affected port pair (see [CALCulate<Ch>:TRANSform:VNETworks:PPAir:DEEMbedding<ListId>:DEFine](#))

<1|2|3> Index i of the conductance G<i> in the related lumped circuit model. If unspecified the numeric suffix is set to 1.

Parameters:

<Conductance> Conductance G<i> for the specified circuit model.
 Range: -1kS to 1 kS.
 Increment: 1 nS (1E-9 S)
 *RST: 0 S
 Default unit: Siemens (SI unit symbol: S)

Parameters for setting and query:

<CircuitModel> STSG | SGST | GSSL | LSSG | GSSG | SLGS | SGLS | SGGS
 Circuit model whose conductance G<i> shall be set, see [Table 8-7](#)

Manual operation: See "[Network](#)" on page 468

CALCulate<Ch>:TRANSform:VNETworks:PPAir:DEEMbedding<ListId>:

PARAMeters:L<1|2|3> <CircuitModel>, <Inductance>

CALCulate<Ch>:TRANSform:VNETworks:PPAir:DEEMbedding<ListId>:

PARAMeters:L<1|2|3>? <CircuitModel>

Specifies the inductance value L<i> in the different lumped circuit models for port pair deembedding.

In the query form, the <Inductance> parameter must be omitted. The command returns the inductance value for the specified circuit model.

Suffix:

<Ch> Channel number

<ListId> Index of the affected port pair (see [CALCulate<Ch>:TRANSform:VNETworks:PPAir:DEEMbedding<ListId>:DEFine](#))

<1|2|3> Index i of the inductance L<i> in the related lumped circuit model. If unspecified the numeric suffix is set to 1.

Parameters:

<Inductance> Inductance L<i>
 Range: -1 H to 1 H.
 Increment: 1 pH (1E-12 H)
 *RST: 1 nH (1E-9 H)
 Default unit: H

Parameters for setting and query:

<CircuitModel> STSL | SLST | CSSL | LSSC | LSSL | SLCS | SCLS | SLLS | GSSL | LSSG | SLGS | SGLS

Circuit model whose inductance L<i> shall be set, see [Table 8-7](#)

Example: See `CALCulate<Ch>:TRANSform:VNETworks:PPAir:DEEMbedding<ListId>[:STATE]`

Manual operation: See "Network" on page 468

**CALCulate<Ch>:TRANSform:VNETworks:PPAir:DEEMbedding<ListId>:
PARAMeters:R<1|2|3> <CircuitModel>[, <Resistance>]**

Specifies the resistance value R<i> in the different lumped circuit models for port pair deembedding.

In the query form, the <Resistance> parameter must be omitted. The command returns the resistance value for the specified circuit model.

Suffix:

<Ch> Channel number

<ListId> Index of the affected port pair (see `CALCulate<Ch>:TRANSform:VNETworks:PPAir:DEEMbedding<ListId>:DEFine`)

<1|2|3> Index i of the resistance R<i> in the related lumped circuit model. If unspecified the numeric suffix is set to 1.

Parameters:

<CircuitModel> STSL | STSC | SLST | SCST | CSSL | LSSC | CSSC | LSSL | SLCS | SCLS | SCCS | SLLS | GSSL | LSSG | SLGS | SGLS

Circuit model whose resistance R<i> shall be set, see [Table 8-7](#)

<Resistance> Resistance R<i> for the specified circuit model.

Range: -10 MΩ to 10 MΩ

Increment: 1 mΩ

*RST: 0 Ω if the resistance is connected in series with an inductance. 10 MΩ if the resistance is connected in parallel with a capacitance)

Default unit: Ohm

Example: See `CALCulate<Ch>:TRANSform:VNETworks:PPAir:DEEMbedding<ListId>[:STATE]`

Manual operation: See "Network" on page 468

**CALCulate<Ch>:TRANSform:VNETworks:PPAir:DEEMbedding<ListId>:
TNDefinition <arg0>**

Selects the circuit model for port pair deembedding.

Suffix:

<Ch> Channel number

<ListId> Index of the affected port pair (see `CALCulate<Ch>:TRANSform:VNETworks:PPAir:DEEMbedding<ListId>:DEFine`)

Parameters:

<arg0> FIMPort | STSL | STSC | SLST | SCST | CSSL | LSSC | CSSC |
LSSL | SLCS | SCLS | SCCS | SLLS | STSG | SGST | GSSL |
LSSG | GSSG | SLGS | SGLS | SGGS

Circuit model to be used for the addressed port pair, see
[Table 8-7](#)

Example:

See `CALCulate<Ch>:TRANSform:VNETworks:PPAir:DEEMbedding<ListId>[:STATE]`

Manual operation: See "[Network](#)" on page 468

CALCulate<Ch>:TRANSform:VNETworks:PPAir:EMBedding<ListId>[:STATE]
<Boolean>

Enables or disables the embedding function for **port set** <ListId>. It is allowed to change the embedding network while embedding is enabled.

Suffix:

<Ch> Channel number

<ListId> Index of the affected **port set** (see `CALCulate<Ch>:TRANSform:VNETworks:PPAir:EMBedding<ListId>:DEFine`)

Parameters:

<Boolean> **OFF** (0): Embedding inactive
ON (1): Embedding active
***RST:** OFF (0)

Example:

```
*RST; CALC:TRAN:VNET:PPA:EMB:DEF 1,2,3,4
Define a port pair configuration with port pairs (1,2) and (3,4).
CALC:TRAN:VNET:PPA:EMB1:TND CSSL
Select the Serial Cs, shunt L circuit model for the first port pair.
CALC:TRAN:VNET:PPA:EMB1:PAR:
R3 CSSL, 2.2E+3; CALC:TRAN:VNET:PPA:EMB1 ON
Increase the resistance R3 for the Serial Cs, shunt L circuit
model to 2.2 kΩ and enable deembedding.
CALC:TRAN:VNET:PPA:EMB:DEL
Delete the port pair configuration.
```

Manual operation: See "[Active](#)" on page 439

CALCulate<Ch>:TRANSform:VNETworks:PPAir:EMBedding<ListId>:DEFine
<PP_First>,<PP_Second>,<PP_First>,...

Creates one or more port pairs for port set embedding. The command can be used repeatedly to extend or (partially) overwrite the list of port sets for embedding.

See `CALCulate<Ch>:TRANSform:VNETworks:PSET:EMBedding<ListId>:DEFine` for general port set definition.

Suffix:	
<Ch>	Channel number
<ListId>	Index of the defined port set within the channel's overall list of port sets for embedding. Port sets for embedding must be numbered consecutively, i.e. port set <ListId> can only be created if port set <ListId>-1 already exists. If several port pairs are specified, <ListId> is the number of the first port pair to be created.
Parameters:	
<PP_First>, <PP_Second>, <PP_First>, ...	Sequence of port pairs, each one consisting of two different ports.
Example:	See <code>CALCulate<Ch>:TRANSform:VNETworks:PPAir:EMBedding<ListId>[:STATE]</code>
Usage:	Setting only
Manual operation:	See "Add / Delete" on page 438

CALCulate<Ch>:TRANSform:VNETworks:PPAir:EMBedding<ListId>:DELeTe

Deletes all port sets (including port pairs) previously defined for embedding.

Suffix:	
<Ch>	Channel number
<ListId>	This suffix is ignored
Example:	See <code>CALCulate<Ch>:TRANSform:VNETworks:PPAir:EMBedding<ListId>[:STATE]</code>
Usage:	Event
Manual operation:	See "Add / Delete" on page 438

CALCulate<Ch>:TRANSform:VNETworks:PPAir:EMBedding<ListId>:PARAmeters:

C<1|2|3> <CircuitModel>, <Capacitance>

CALCulate<Ch>:TRANSform:VNETworks:PPAir:EMBedding<ListId>:PARAmeters:

C<1|2|3>? <CircuitModel>

Specifies the capacitance value C<i> in the different lumped circuit models for port pair embedding.

In the query form, the <Capacitance> parameter must be omitted. The command returns the capacitance value for the specified circuit model.

Suffix:	
<Ch>	Channel number
<ListId>	Index of the affected port pair (see <code>CALCulate<Ch>:TRANSform:VNETworks:PPAir:DEEMbedding<ListId>:DEFine</code>)

<1|2|3> Index *i* of the capacitance $C_{<i>}$ in the related lumped circuit model. If unspecified the numeric suffix is set to 1.

Parameters:

<Capacitance> Capacitance C_i
 Range: -1 mF to 1 mF
 Increment: 1 fF (1E-15 F)
 *RST: 1 pF (1E-12 F)
 Default unit: F

Parameters for setting and query:

<CircuitModel> STSC | SCST | CSSL | LSSC | CSSC | SLCS | SCLS | SCCS | STSG | SGST | GSSL | LSSG | GSSG | SLGS | SGLS | SGGS
 Circuit model whose capacitance $C_{<i>}$ shall be set, see [Table 8-7](#)

Example: See `CALCulate<Ch>:TRANSform:VNETworks:PPAir:EMBedding<ListId>[:STATE]`

Manual operation: See "Network" on page 468

**CALCulate<Ch>:TRANSform:VNETworks:PPAir:EMBedding<ListId>:PARAmeters:
 L<1|2|3> <arg0>, <Inductance>**

**CALCulate<Ch>:TRANSform:VNETworks:PPAir:EMBedding<ListId>:PARAmeters:
 L<1|2|3>? <arg0>**

Specifies the inductance value $L_{<i>}$ in the different lumped circuit models for port pair embedding.

In the query form, the <Inductance> parameter must be omitted. The command returns the inductance value for the specified circuit model.

Suffix:

<Ch> Channel number
 <ListId> Index of the affected port pair (see `CALCulate<Ch>:TRANSform:VNETworks:PPAir:DEEMbedding<ListId>:DEFine`)

<1|2|3> Index *i* of the inductance $L_{<i>}$ in the related lumped circuit model. If unspecified the numeric suffix is set to 1.

Parameters:

<Inductance> Inductance $L_{<i>}$
 Range: -1 H to 1 H.
 Increment: 1 pH (1E-12 H)
 *RST: 1 nH (1E-9 H)
 Default unit: H

Parameters for setting and query:

<arg0> STSL | SLST | CSSL | LSSC | LSSL | SLCS | SCLS | SLLS | GSSL | LSSG | SLGS | SGLS
 Circuit model whose inductance $L_{<i>}$ shall be set, see [Table 8-7](#)

Example: See `CALCulate<Ch>:TRANSform:VNETworks:PPAir:EMBedding<ListId>[:STATE]`

Manual operation: See "Network" on page 468

**CALCulate<Ch>:TRANSform:VNETworks:PPAir:EMBedding<ListId>:PARAmeters:
R<1|2|3> <arg0>, <Resistance>**

**CALCulate<Ch>:TRANSform:VNETworks:PPAir:EMBedding<ListId>:PARAmeters:
R<1|2|3>? <arg0>**

Specifies the resistance value R<i> in the different lumped circuit models for port pair embedding.

In the query form, the <Resistance> parameter must be omitted. The command returns the resistance value for the specified circuit model.

Suffix:

<Ch> Channel number

<ListId> Index of the affected port pair (see `CALCulate<Ch>:TRANSform:VNETworks:PPAir:DEEMbedding<ListId>:DEFine`)

<1|2|3> Index i of the resistance R<i> in the related lumped circuit model. If unspecified the numeric suffix is set to 1.

Parameters:

<Resistance> Resistance R<i> for the specified circuit model.
 Range: -10 MΩ to 10 MΩ
 Increment: 1 mΩ
 *RST: 0 Ω if the resistance is connected in series with an inductance. 10 MΩ if the resistance is connected in parallel with a capacitance)
 Default unit: Ohm

Parameters for setting and query:

<arg0> STSL | STSC | SLST | SCST | CSSL | LSSC | CSSC | LSSL | SLCS | SCLS | SCCS | SLLS | GSSL | LSSG | SLGS | SGLS
 Circuit model whose resistance R<i> shall be set, see [Table 8-7](#)

Example: See `CALCulate<Ch>:TRANSform:VNETworks:PPAir:EMBedding<ListId>[:STATE]`

Manual operation: See "Network" on page 468

**CALCulate<Ch>:TRANSform:VNETworks:PPAir:EMBedding<ListId>:PARAmeters:
G<1|2|3> <arg0>, <Conductance>**

**CALCulate<Ch>:TRANSform:VNETworks:PPAir:EMBedding<ListId>:PARAmeters:
G<1|2|3>? <arg0>**

Specifies the conductance value G<i> in the different lumped circuit models for port pair embedding.

In the query form, the <Conductance> parameter must be omitted. The command returns the conductance value for the specified circuit model.

Suffix:

<Ch>	Channel number
<ListId>	Index of the affected port pair (see CALCulate<Ch>:TRANSform:VNETworks:PPAir:DEEMbedding<ListId>:DEFine)
<1 2 3>	Index i of the conductance G<i> in the related lumped circuit model. If unspecified the numeric suffix is set to 1.

Parameters:

<Conductance>	Conductance G<i> for the specified circuit model. Range: -1kS to 1 kS. Increment: 1 pS (1E-12 S) *RST: 0 S Default unit: Siemens (SI unit symbol: S)
---------------	--

Parameters for setting and query:

<arg0>	STSG SGST GSSL LSSG GSSG SLGS SGLS SGGS Circuit model whose conductance G<i> shall be set, see Table 8-7
--------	---

Manual operation: See "[Network](#)" on page 468

CALCulate<Ch>:TRANSform:VNETworks:PPAir:EMBedding<ListId>:TNDefinition <CircuitModel>

Selects the circuit model for port pair embedding.

Suffix:

<Ch>	Channel number
<ListId>	Index of the affected port pair (see CALCulate<Ch>:TRANSform:VNETworks:PPAir:EMBedding<ListId>:DEFine)

Parameters:

<CircuitModel>	FIMPort STSL STSC SLST SCST CSSL LSSC CSSC LSSL SLCS SCLS SCCS SLLS STSG SGST GSSL LSSG GSSG SLGS SGLS SGGS Circuit model to be used for the addressed port pair, see Table 8-7
----------------	--

Example:

See [CALCulate<Ch>:TRANSform:VNETworks:PPAir:EMBedding<ListId>\[:STATE\]](#)

Manual operation: See "[Network](#)" on page 468

CALCulate<Ch>:TRANSform:VNETworks:PSET:DEEMbedding<ListId>:DEFine
 <Port1>, <Port2>[, <Port3>[, <Port4>]]

CALCulate<Ch>:TRANSform:VNETworks:PSET:EMBedding<ListId>:DEFine
 <Port1>, <Port2>, ...

Defines port set <ListId> for port set deembedding|embedding.

Note that **port pairs** (i.e. 2-element port sets) can also be created using
 CALCulate<Ch>:TRANSform:VNETworks:PPAir:DEEMbedding<ListId>:
 DEFine / CALCulate<Ch>:TRANSform:VNETworks:PPAir:
 EMBedding<ListId>:DEFine.

Use CALCulate<Ch>:TRANSform:VNETworks:PPAir:DEEMbedding:DELeTe /
 CALCulate<Ch>:TRANSform:VNETworks:PPAir:EMBedding<ListId>:DELeTe
 on page 769 to delete all port sets (including port pairs).

Suffix:

<Ch> Channel number

<ListId> Index of the defined port set within the channel's overall list of
 port sets for deembedding/embedding.

Parameters:

<Port1>, <Port2>, ... A port set consist of two or more (different) ports.
 A port can be an element of multiple port sets.

Manual operation: See "Add / Delete" on page 438

**CALCulate<Ch>:TRANSform:VNETworks:SENDEd:DEEMbedding<PhyPt>[:
 STATE] <Boolean>**

Enables or disables the deembedding function for single ended ports. It is allowed to
 change the circuit model and its parameters while deembedding is enabled.

Suffix:

<Ch> Channel number

<PhyPt> Physical port number

Parameters:

<Boolean> ON - deembedding active
 OFF - deembedding inactive
 *RST: OFF

Example:

CALC:TRAN:VNET:SEND:DEEM:TND CSL

Select the Serial C, shunt L circuit model for deembedding.

CALC:TRAN:VNET:SEND:DEEM:PAR:R2 CSL, 2.2E+3; :

CALC:TRAN:VNET:SEND:DEEM ON

Increase the resistance R2 for the Serial C, shunt L circuit model
 to 2.2 kΩ and enable deembedding.

Manual operation: See "Active" on page 437

**CALCulate<Ch>:TRANSform:VNETworks:SENDED:DEEMbedding<PhyPt>:
PARAmeters:DATA <Interchange>, <arg1>**

Defines an embedding network for a single-ended port based on the given S-Parameter traces.

Use

- `CALCulate<Ch>:TRANSform:VNETworks:SENDED:DEEMbedding<PhyPt>:TNDefinition` to select the adequate circuit model **before** executing this command.
- `MMEMemory:LOAD:VNETworks<Ch>:SENDED:DEEMbedding<PhyPt>` to load circuit data from a Touchstone file located at the R&S ZND's file system.

Suffix:

<Ch> Channel number
<PhyPt> Physical port number

Setting parameters:

<Interchange> FPORts | IPORts | SGATes
FPORts (or omitted)
 Standard port sequence (network port 1 towards VNA, network port 2 towards DUT)
IPORts | SGATes
 Inverted port sequence (network port 2 towards VNA, network port 1 towards DUT)

<arg1> <block_data>
 Content of a Touchstone file (*.s2p) in IEEE488.2 [Block Data Format](#).

Usage: Setting only

**CALCulate<Ch>:TRANSform:VNETworks:SENDED:DEEMbedding<PhyPt>:
PARAmeters:C<Cmp> <CircuitModel>, <Capacitance>
CALCulate<Ch>:TRANSform:VNETworks:SENDED:DEEMbedding<PhyPt>:
PARAmeters:C<Cmp>? <CircuitModel>**

Specifies the capacitance value C<Cmp> in the different circuit models for single ended port embedding.

In the query form, the <Capacitance> parameter must be omitted. The command returns the capacitance value for the specified circuit model.

Suffix:

<Ch> Channel number
<PhyPt> Physical port number
<Cmp> Number of capacitance in circuit model. The total number of capacitances depends on the selected circuit model.

Parameters:

<Capacitance> Capacitance C<Cmp> for the specified circuit model.
 Range: -1mF to 1 mF.
 Increment: 1 fF (1E-15 F)
 *RST: 1 pF (1E-12 F)
 Default unit: F

Parameters for setting and query:

<CircuitModel> CSL | LSC | CSC | SLC | SCL | SCC | SHLC | GSL | LSG |
 GSG | SLG | SGL | SGG
 Possible circuit models (character data); see [Table 8-6](#).

Example:

```
*RST; :CALC:TRAN:VNET:SEND:DEEM:PAR:C2? CSC
Query the default capacitance C2 for the Serial C, shunt C cir-
cuit model. The response is 1E-012 (1 pF).
CALC:TRAN:VNET:SEND:DEEM:PAR:C2 CSC, 2.2E-12
Increase the capacitance to 2.2 pF.
```

Manual operation: See "[Network](#)" on page 453

CALCulate<Ch>:TRANSform:VNETworks:SENDEd:DEEMbedding<PhyPt>:

PARAmeters:G<Cmp> <CircuitModel>, <Conductance>

CALCulate<Ch>:TRANSform:VNETworks:SENDEd:DEEMbedding<PhyPt>:

PARAmeters:G<Cmp>? <CircuitModel>

Specifies the conductance value G in the "shunt L, shunt C" circuit model for single ended port deembedding.

In the query form, the <Conductance> parameter must be omitted.

Suffix:

<Ch> Channel number
 <PhyPt> Physical port number
 <Cmp> Number of the conductance component in the circuit model. The total number of conductances depends on the selected circuit model.

Parameters:

<Conductance> Conductance G<Cmp> for the specified circuit model.
 Range: -1kS to 1 kS.
 Increment: 1 nS (1E-9 S)
 *RST: 0 S
 Default unit: Siemens (SI unit symbol: S)

Parameters for setting and query:

<CircuitModel> SHLC
 Circuit model whose conductance G<Cmp> shall be set, see [Table 8-6](#).

Example: *RST; :CALC:TRAN:VNET:SEND:DEEM:PAR:L? SHLC; R?
SHLC; C? SHLC; G? SHLC
Query the default component values for the "shunt L, shunt C"
circuit model.
CALC:TRAN:VNET:SEND:DEEM:PAR:G SHLC, 1
Increase the conductance G to 1 Siemens.

Manual operation: See "[Network](#)" on page 453

CALCulate<Ch>:TRANSform:VNETworks:SENDEd:DEEMbedding<PhyPt>:

PARAMeters:L<Cmp> <CircuitModel>, <Inductance>

CALCulate<Ch>:TRANSform:VNETworks:SENDEd:DEEMbedding<PhyPt>:

PARAMeters:L<Cmp>? <CircuitModel>

Specifies the inductance value L<Cmp> in the different circuit models for single ended port deembedding.

In the query form, the <Inductance> parameter must be omitted. The command returns the inductance value for the specified circuit model.

Suffix:

<Ch> Channel number

<PhyPt> Physical port number

<Cmp> Number of inductance in circuit model. The total number of inductances depends on the selected circuit model.

Parameters:

<Inductance> Inductance L<Cmp> for the specified circuit model.

Range: -1H to 1 H.

Increment: 1 pH (1E-12 H)

*RST: 1 nH (1E-9 H)

Default unit: H

Parameters for setting and query:

<CircuitModel> CSL | LSC | LSL | SLC | SCL | SLL | SHLC | GSL | LSG | SLG | SGL

Possible circuit models (character data); see [Table 8-6](#).

Example: *RST; :CALC:TRAN:VNET:SEND:DEEM:PAR:L1? SLL
Query the default inductance L1 for the Shunt L, serial L circuit model. The response is 1E-009 (1 nH).

CALC:TRAN:VNET:SEND:DEEM:PAR:L1 SLL, 2.2E-9

Increase the inductance to 2.2 nH.

Manual operation: See "[Network](#)" on page 453

**CALCulate<Ch>:TRANSform:VNETworks:SENDEd:DEEMbedding<PhyPt>:
PARAmeters:R<Cmp> <CircuitModel>, <Resistance>
CALCulate<Ch>:TRANSform:VNETworks:SENDEd:DEEMbedding<PhyPt>:
PARAmeters:R<Cmp>? <CircuitModel>**

Specifies the resistance value R<Cmp> in the different circuit models for single ended port deembedding.

In the query form, the <Resistance> parameter must be omitted. The command returns the resistance value for the specified circuit model.

Suffix:

<Ch> Channel number
 <PhyPt> Physical port number
 <Cmp> Number of resistance in circuit model. The total number of resistances depends on the selected circuit model.

Parameters:

<Resistance> Resistance R<Cmp> for the specified circuit model.
 Range: -10 MΩ to 10 MΩ.
 Increment: 1 mΩ (1E-3 Ω)
 *RST: 0 Ω for all resistances connected in series with an inductance. 10 MΩ for all resistances connected in parallel with a capacitance
 Default unit: Ohm

Parameters for setting and query:

<CircuitModel> CSL | LSC | CSC | LSL | SLC | SCL | SCC | SLL | SHLC | GSL | LSG | SLG | SGL
 Possible circuit models (character data); see [Table 8-6](#).

Example:

```
*RST; :CALC:TRAN:VNET:SEND:DEEM:PAR:R1? CSL;
R2? CSL
Query the default resistances for the Serial C, shunt L circuit
model. The response is 10000000; 0.
CALC:TRAN:VNET:SEND:DEEM:PAR:R2 CSL, 2.2E+3
Increase the resistance R2 to 2.2 kΩ.
```

Manual operation: See "[Network](#)" on page 453

**CALCulate<Ch>:TRANSform:VNETworks:SENDEd:DEEMbedding<PhyPt>:
TNDefinition <CircuitModel>**

Selects the circuit model for single ended port deembedding.

Suffix:

<Ch> Channel number
 <PhyPt> Physical port number

Parameters:

<CircuitModel> FIMPort | CSL | LSC | CSC | LSL | SLC | SCL | SCC | SLL | SHLC | GSL | LSG | GSG | SLG | SGL | SGG

Possible circuit models (character data); see [Table 8-6](#)

*RST: CSL

Example:

See [CALCulate<Ch>:TRANSform:VNETworks:SENDED:DEEMbedding<PhyPt>\[:STATe\]](#)

Manual operation: See "[Network](#)" on page 453

CALCulate<Ch>:TRANSform:VNETworks:SENDED:EMBedding<PhyPt>[:STATe] <Boolean>

Enables or disables the embedding function for single ended ports. It is allowed to change the circuit model and its parameters while embedding is enabled.

Suffix:

<Ch> Channel number

<PhyPt> Physical port number

Parameters:

<Boolean> ON - embedding active
OFF - embedding inactive

*RST: OFF

Example:

CALC:TRAN:VNET:SEND:EMB:TND CSL

Select the Serial C, shunt L circuit model for embedding.

CALC:TRAN:VNET:SEND:EMB:PAR:R2 CSL, 2.2E+3; :

CALC:TRAN:VNET:SEND:EMB ON

Increase the resistance R2 for the Serial C, shunt L circuit model to 2.2 kΩ and enable embedding.

Manual operation: See "[Active](#)" on page 437

CALCulate<Ch>:TRANSform:VNETworks:SENDED:EMBedding<PhyPt>: PARAmeters:DATA <Interchange>, <arg1>

Defines a dembedding network for a single-ended port based on the given S-Parameter traces.

Use

- [CALCulate<Ch>:TRANSform:VNETworks:SENDED:EMBedding<PhyPt>:TNDefinition](#) to select the adequate circuit model **before** executing this command.
- [MMEMemory:LOAD:VNETworks<Ch>:SENDED:EMBedding<PhyPt>](#) to load circuit data from a Touchstone file located at the R&S ZND's file system.

Suffix:

<Ch> Channel number

<PhyPt> Physical port number

Setting parameters:

<Interchange> FPORts | IPORts | SGATes

FPORts (or omitted)

Standard port sequence (network port 1 towards VNA, network port 2 towards DUT)

IPORts | SGATes

Inverted port sequence (network port 2 towards VNA, network port 1 towards DUT)

<arg1> <block_data>

Content of a Touchstone file (*.s2p or *.s4p) in IEEE488.2 [Block Data Format](#).

Usage: Setting only

CALCulate<Ch>:TRANSform:VNETworks:SENDEd:EMBedding<PhyPt>:

PARAmeters:C<Cmp> <CircuitModel>, <Capacitance>

CALCulate<Ch>:TRANSform:VNETworks:SENDEd:EMBedding<PhyPt>:

PARAmeters:C<Cmp>? <CircuitModel>

Specifies the capacitance value C<Cmp> in the different circuit models for single ended port embedding.

In the query form, the <Capacitance> parameter must be omitted. The command returns the capacitance value for the specified circuit model.

Suffix:

<Ch> Channel number

<PhyPt> Physical port number

<Cmp> Number of capacitance in circuit model. The total number of capacitances depends on the selected circuit model.

Parameters:

<Capacitance> Capacitance C<Cmp> for the specified circuit model.

Range: -1mF to 1 mF.

Increment: 1 fF (1E-15 F)

*RST: 1 pF (1E-12 F)

Default unit: F

Parameters for setting and query:

<CircuitModel> CSL | LSC | CSC | SLC | SCL | SCC | SHLC | GSL | LSG | GSG | SLG | SGL | SGG

Possible circuit models (character data); see [Table 8-6](#).

Example:

*RST; :CALC:TRAN:VNET:SEND:EMB:PAR:C2? CSC

Query the default capacitance C2 for the Serial C, shunt C circuit model. The response is 1E-012 (1 pF).

CALC:TRAN:VNET:SEND:EMB:PAR:C2 CSC, 2.2E-12

Increase the capacitance to 2.2 pF.

Manual operation: See "[Network](#)" on page 453

**CALCulate<Ch>:TRANSform:VNETworks:SENDEd:EMBEdding<PhyPt>:
PARAmeters:G<Cmp>** <CircuitModel>, <Conductance>
**CALCulate<Ch>:TRANSform:VNETworks:SENDEd:EMBEdding<PhyPt>:
PARAmeters:G<Cmp>?** <CircuitModel>

Specifies the conductance value G<Cmp> in the different circuit models for single ended port embedding.

In the query form, the <Conductance> parameter must be omitted. The command returns the conductance value for the specified circuit model.

Suffix:

<Ch>	Channel number
<PhyPt>	Physical port number
<Cmp>	Number of the conductance component in the circuit model. The total number of conductances depends on the selected circuit model.

Parameters:

<Conductance>	Conductance G<Cmp> for the specified circuit model. Range: -1kS to 1 kS. Increment: 1 pS (1E-12 S) *RST: 0 S Default unit: Siemens (SI unit symbol: S)
---------------	--

Parameters for setting and query:

<CircuitModel>	GSL LSG GSG SLG SGL SGG SHLC Circuit model whose conductance G<Cmp> shall be set, see Table 8-6 .
----------------	--

Example:

```
*RST; :CALC:TRAN:VNET:SEND:EMB:PAR:L? SHLC; R?
SHLC; C? SHLC; G? SHLC
Query the default component values for the "shunt L, shunt C"
circuit model.
CALC:TRAN:VNET:SEND:EMB:PAR:G SHLC, 1
Increase the conductance G to 1 Siemens.
```

Manual operation: See "[Network](#)" on page 453

**CALCulate<Ch>:TRANSform:VNETworks:SENDEd:EMBEdding<PhyPt>:
PARAmeters:L<Cmp>** <CircuitModel>, <Inductance>
**CALCulate<Ch>:TRANSform:VNETworks:SENDEd:EMBEdding<PhyPt>:
PARAmeters:L<Cmp>?** <CircuitModel>

Specifies the inductance value L<Cmp> in the different circuit models for single ended port embedding.

In the query form, the <Inductance> parameter must be omitted. The command returns the inductance value for the specified circuit model.

Suffix:

<Ch>	Channel number
<PhyPt>	Physical port number
<Cmp>	Number of inductance in circuit model. The total number of inductances depends on the selected circuit model.

Parameters:

<Inductance>	Inductance L<Cmp> for the specified circuit model. Range: -1H to 1 H. Increment: 1 pH (1E-12 H) *RST: 1 nH (1E-9 H) Default unit: H
--------------	---

Parameters for setting and query:

<CircuitModel>	CSL LSC LSL SLC SCL SLL SHLC GSL LSG SLG SGL Possible circuit models (character data); see Table 8-6 .
----------------	---

Example:

```
*RST; :CALC:TRAN:VNET:SEND:EMB:PAR:L1? SLL
Query the default inductance L1 for the Shunt L, serial L circuit
model. The response is 1E-009 (1 nH).
CALC:TRAN:VNET:SEND:EMB:PAR:L1 SLL, 2.2E-9
Increase the inductance to 2.2 nH.
```

Manual operation: See "[Network](#)" on page 453

CALCulate<Ch>:TRANSform:VNETworks:SENDED:EMBedding<PhyPt>:

PARAMeters:R<Cmp> <CircuitModel>, <Resistance>

CALCulate<Ch>:TRANSform:VNETworks:SENDED:EMBedding<PhyPt>:

PARAMeters:R<Cmp>? <CircuitModel>

Specifies the resistance value R<Cmp> in the different circuit models for single ended port embedding.

In the query form, the <Resistance> parameter must be omitted. The command returns the resistance value for the specified circuit model.

Suffix:

<Ch>	Channel number
<PhyPt>	Physical port number
<Cmp>	Number of resistance in circuit model. The total number of resistances depends on the selected circuit model.

Parameters:

<Resistance> Resistance R<Cmp> for the specified circuit model.
 Range: -10 MΩ to 10 MΩ.
 Increment: 1 mΩ (1E-3 Ω)
 *RST: 0 Ω for all resistances connected in series with an inductance. 10 MΩ for all resistances connected in parallel with a capacitance
 Default unit: Ohm

Parameters for setting and query:

<CircuitModel> CSL | LSC | CSC | LSL | SLC | SCL | SCC | SLL | SHLC | GSL | LSG | SLG | SGL

Possible circuit models (character data); see [Table 8-6](#).

Example:

```
*RST; :CALC:TRAN:VNET:SEND:EMB:PAR:R1? CSL; R2? CSL
```

Query the default resistances for the Serial C, shunt L circuit model. The response is 10000000; 0.

```
CALC:TRAN:VNET:SEND:EMB:PAR:R2 CSL, 2.2E+3
```

Increase the resistance R2 to 2.2 kΩ.

Manual operation: See "[Network](#)" on page 453

**CALCulate<Ch>:TRANSform:VNETworks:SENDEd:EMBedding<PhyPt>:
 TNDefinition <CircuitModel>**

Selects the circuit model for single ended port embedding.

Suffix:

<Ch> Channel number

<PhyPt> Physical port number

Parameters:

<CircuitModel> FIMPort | CSL | LSC | CSC | LSL | SLC | SCL | SCC | SLL | SHLC | GSL | LSG | GSG | SLG | SGL | SGG

Possible circuit models (character data); see [Table 8-6](#)

*RST: CSL

Example:

See `CALCulate<Ch>:TRANSform:VNETworks:SENDEd:EMBedding<PhyPt>[:STATe]`

Manual operation: See "[Network](#)" on page 453

CALCulate<Ch>:TRANSform:VNETworks:WAVes <Boolean>

Defines whether the wave-based, or the classical S parameter-based de-/embedding calculation is used in channel <Ch>.

Suffix:**<Ch>** Channel number**Parameters:**

<Boolean>

ON (1)
Wave-based calculation (default)

OFF (0)
S parameter-based calculation

Manual operation: See "[Offset > Wave De-/Embed.](#)" on page 477

8.3.2 CONFigure Commands

The `CONFigure...` commands create and delete channels or traces, assign channel and trace names, and define the channel sweep order. The commands are device-specific.

<code>CONFigure:CHANnel:CATalog?</code>	783
<code>CONFigure:CHANnel:MEASure:ALL[:STATe]</code>	784
<code>CONFigure:CHANnel:MEASure:OPTimized</code>	784
<code>CONFigure:CHANnel<Ch>[:STATe]</code>	785
<code>CONFigure:CHANnel<Ch>:MEASure[:STATe]</code>	786
<code>CONFigure:CHANnel<Ch>:NAME</code>	786
<code>CONFigure:CHANnel<Ch>:NAME:ID?</code>	786
<code>CONFigure:CHANnel<Ch>:TRACe:REName</code>	787
<code>CONFigure:CHANnel<Ch>:TRACe:CATalog?</code>	787
<code>CONFigure:TRACe:CATalog?</code>	788
<code>CONFigure:TRACe:WINDow?</code>	788
<code>CONFigure:TRACe:WINDow:TRACe?</code>	789
<code>CONFigure:TRACe<Trc>:CHANnel:NAME?</code>	789
<code>CONFigure:TRACe<Trc>:CHANnel:NAME:ID?</code>	789
<code>CONFigure:TRACe<Trc>:NAME</code>	790
<code>CONFigure:TRACe<Trc>:NAME:ID?</code>	790
<code>CONFigure:TRACe<Trc>:REName</code>	790

CONFigure:CHANnel:CATalog?

Returns the numbers and names of all channels in the current recall set. The response is a string containing a comma-separated list of channel numbers and names; see example below. If all channels have been deleted the response is an empty string ("").

Example:

```
*RST; :CONF:CHAN2:STAT ON; NAME 'New Channel'
Create channel 2 and assign the channel name "New Channel".
CONF:CHAN:CAT?
Query all channels and their names. As a default channel no. 1
is created on *RST, the response is
'1,Ch1,2,New_Channel'.
CONF:CHAN:NAME:ID? 'New Channel'
Query the channel number for the channel named "New Chan-
nel". The response is 2.
```

Usage: Query only

Manual operation: See "Channel table" on page 429

CONFigure:CHANnel:MEASure:ALL[:STATe] <Boolean>

Enables or disables the sweep in all channels of the active recall set. This command can be used in combination with `CONFigure:CHANnel<Ch>:MEASure[:STATe]` to optimize the measurement speed.

Parameters:

<Boolean> ON | OFF
*RST: ON

Example: See `CONFigure:CHANnel<Ch>:MEASure[:STATe]`

Manual operation: See "Continuous / Single" on page 370

CONFigure:CHANnel:MEASure:OPTimized <Order>[, <Ch1>, <Ch2>, ...]

This setting tells the firmware to optimize the channel switching times for a particular channel sweep order.

Note that the optimization can only be applied, if **all** channels in the current setup are in single sweep mode (`INITiate<Ch>:CONTinuous OFF`), and if there is no ongoing sweep sequence. Any change in the current setup or a wrong sweep sequence lets the analyzer fall back to unoptimized channel switching.

Setting parameters:

<Order> AUTO | MANual

AUTO

Optimize the switching times for the channel order that is automatically used with `INIT:ALL` (increasing order of channel numbers).

MANual

Optimize the switching times for the channel order manually specified using channel numbers <Ch1>, <Ch2>, ...

<Ch1>, <Ch2>, ... Can only and must be specified for MANual optimized channel ordering. Defines the order in which the channels are measured. To get the optimization to work, you have to sweep the channels manually, and in the specified order: `INIT<Ch1>`, `INIT<Ch2>`, ...

Example:

```
*RST;
*RST creates channel 1, trace 1, and diagram 1.
:INITiate1:CONTinuous OFF
enable single sweep mode
CALC2:PAR:SDEF 'Ch2Tr1', 'S11'
CALC3:PAR:SDEF 'Ch3Tr1', 'S11'
CALC4:PAR:SDEF 'Ch4Tr1', 'S11'

create additional channels 2, 3 and 4 with one trace each
DISP:WIND1:TRAC2:FEED 'CH2TR1'
DISP:WIND1:TRAC3:FEED 'CH3TR1'
DISP:WIND1:TRAC4:FEED 'CH4TR1'

assign these traces to diagram 1
:CONF:CHAN:MEAS:OPT AUTO; :INITiate1:IMMediate:
ALL
optimize the switching times for the AUTOMatic channel order
1,2,3,4, and restart the sweep in all channels
:CONF:CHAN:MEAS:OPT MAN, 2,3,1,4; :INIT2; :
INIT3; :INIT1; :INIT4
optimize the switching times for channel order 2,3,1,4 and
restart the sweeps in the same order
```

Usage: Setting only

CONFigure:CHANnel<Ch>[:STATe] <Boolean>

Creates or deletes channel no. <Ch> and selects it as the active channel.

CONFigure:CHANnel<Ch>:NAME defines the channel name.

A channel created using CONFigure:CHANnel<Ch>[:STATe] ON can be configured but has no trace assigned so that no measurement can be initiated. Use CALCulate<Ch>:PARAMeter:SDEFine <TraceName>, <Result> to create a channel and a trace. In remote control, it is possible to remove all channels. This is in contrast to manual control where at least one channel with one diagram area and one trace must be available.

Suffix:

<Ch> Number of the channel to be created or deleted.

Parameters:

<Boolean> ON - create channel no. <Ch>. If the channel no. <Ch> exists already, it is not modified but selected as the active channel.
OFF - delete channel no. <Ch>.

*RST: ON for channel no. 1 (created on *RST), OFF for all other channels.

Example: See CONFigure:CHANnel:CATalog?

Manual operation: See "New Channel" on page 427

CONFigure:CHANnel<Ch>:MEASure[:STATe] <Boolean>

Enables or disables the sweep in channel no. <Ch>. This command can be used to restrict the measurement in a subset of channels in order to optimize the measurement speed.

Suffix:

<Ch> Number of an existing channel.

Parameters:

<Boolean> ON | OFF
 *RST: ON (all existing channels)

Example:

```
*RST; :CONFigure:CHANnel2 ON; CHANnel3 ON
Create channels 2 and 3, in addition to the default channel no.
1. The analyzer performs sweeps in all three channels.
CONFigure:CHANnel:MEASure:ALL OFF
Disable the measurement in all channels
CONFigure:CHANnel2:MEASure ON
(Re-)enable the measurement in channel no. 2. The analyzer
measures in channel 2; the channels no. 1 and 3 are not mea-
sured.
```

Manual operation: See "[Continuous / Single](#)" on page 370

CONFigure:CHANnel<Ch>:NAME <ChannelName>

Assigns a name to channel number <Ch>. The channel must be created before ([CONFigure:CHANnel<Ch>\[:STATe\] ON](#)). Moreover it is not possible to assign the same name to two different channels. [CONFigure:CHANnel:CATalog?](#) returns a list of all defined channels with their names.

Suffix:

<Ch> Number of an existing channel.

Parameters:

<ChannelName> Channel name, e.g. 'Channel 4'.
 *RST: 'Ch1'

Example: See [CONFigure:CHANnel:CATalog?](#)

Manual operation: See "[Channel table](#)" on page 429

CONFigure:CHANnel<Ch>:NAME:ID? <ChannelName>

Queries the channel number (numeric suffix) of a channel with known channel name. A channel name must be assigned before ([CONFigure:CHANnel<Ch>:NAME <ChannelName>](#)). [CONFigure:CHANnel:CATalog?](#) returns a list of all defined channels with their names.

Suffix:

<Ch> Channel number. This suffix is not relevant and may be omitted (the command returns the actual channel number).

Query parameters:

<ChannelName> Channel name, e.g. 'Channel 4'.

Example:

See [CONFigure:CHANnel:CATalog?](#)

Usage:

Query only

Manual operation: See ["Table Area"](#) on page 268

CONFigure:CHANnel<Ch>:TRACe:REName <TraceName>

Assigns a (new) name to the active trace in channel <Ch>.

Suffix:

<Ch> Channel number

Setting parameters:

<TraceName> Trace name, e.g. 'Trace 4'.

Example:

```
*RST; :CONF:CHAN:TRAC:REN 'Testtrace_1'
```

Reset the analyzer to create a default trace in channel 1 and set this trace as the active trace. Rename the trace 'Testtrace_1'.

```
CALC:PAR:SDEF 'Testtrace_2', 'S11'
```

Create a new trace which will become the active trace in channel no. 1.

```
CONF:TRAC:REN 'Testtrace_1', 'Testtrace_3'
```

Rename the first trace (which is currently not active) 'Testtrace_3'.

Usage:

Setting only

Manual operation: See ["Table Area"](#) on page 268

CONFigure:CHANnel<Ch>:TRACe:CATalog?

Returns the numbers and names of all traces in channel no. <Ch>. The response is a string containing a comma-separated list of trace numbers and names; see example. If all traces have been deleted the response is an empty string ("").

Tip: Use [CONFigure:TRACe:CATalog?](#) to query the traces in all channels of the active recall set.

Suffix:

<Ch> Channel number

Example:

See [CONFigure:TRACe:CATalog?](#)

Usage:

Query only

Manual operation: See ["Table Area"](#) on page 268

CONFigure:TRACe:CATalog?

Returns the numbers and names of all traces in the current recall set. The response is a string containing a comma-separated list of trace numbers and names, see example below. If all traces have been deleted the response is an empty string ("").

Tip: Use `CONFigure:CHANnel<Ch>:TRACe:CATalog?` to query the traces in a particular channel; see example.

Example:

```
*RST; :CALC2:PAR:SDEF 'Ch2Trc2', 'S11'
```

Create channel 2 and a new trace named Ch2Trc2.

```
CONF:TRAC:CAT?
```

Query all traces and their names. As a default trace no. 1 is created upon *RST, the response is '1,Trc1,2,Ch2Trc2'.

```
CONF:CHAN1:TRAC:CAT?
```

Query the channels in channel no. 1. The response is '1,Trc1'.

```
CONF:TRAC:NAME:ID? 'Ch2Trc2'
```

Query the trace number for the trace named "Ch2Trc2". The response is 2.

```
CONF:TRAC2:NAME?
```

Query the trace name for trace no. 2. The response is 'Ch2Trc2'.

```
CONF:TRAC:CHAN:NAME? 'Ch2Trc2'
```

Query the channel name for trace Ch2Trc2. The response is 'Ch2'.

```
CONF:TRAC:CHAN:NAME:ID? 'Ch2Trc2'
```

Query the channel number for trace Ch2Trc2. The response is 2.

Usage: Query only

Manual operation: See "[Table Area](#)" on page 268

CONFigure:TRACe:WINDow? <TraceName>

Returns the trace number within a diagram which is assigned to the trace <TraceName> is assigned to. A zero is returned when the trace is not assigned/displayed.

The trace number is equal to the <WndTr> suffix in `DISPlay[:WINDow<Wnd>]:TRACe<WndTr>:FEED` and similar commands; see example.

Query parameters:

<TraceName> Trace name (string), e.g. 'Trc1'

Example: See `CONFigure:TRACe:WINDow:TRACe?`

Usage: Query only

CONFigure:TRACe:WINDow:TRACe? <TraceName>

Returns the number of the diagram which the trace <TraceName> is assigned to. A zero is returned when the trace is not assigned/displayed.

The diagram number is equal to the <Wnd> suffix in `DISPlay[:WINDow<Wnd>]:TRACe<WndTr>:FEED` and similar commands; see example.

Query parameters:

<TraceName> Trace name (string), e.g. 'Trc1'

Example:

```
*RST; :CALC:PAR:SDEF 'Trc2', 'S11'
```

Create a trace named Trc2.

```
CONF:TRAC:WIND:TRAC? 'Trc2'
```

Query the diagram number for Trc2. The new trace is not displayed, so the response is 0.

```
DISP:WIND2:STAT ON
```

Create a diagram no. 2.

```
DISP:WIND2:TRAC3:FEED 'Trc2'
```

Display the trace in the new diagram no. 2, assigning the trace number 3.

```
CONF:TRAC:WIND? 'Trc2'
```

Query the diagram number for Trc2. The response is 2.

```
CONF:TRAC:WIND:TRAC? 'Trc2'
```

Query the trace number for Trc2. The response is 3.

Usage: Query only

Manual operation: See ["Table Area"](#) on page 268

CONFigure:TRACe<Trc>:CHANnel:NAME? <TraceName>

Queries the channel name for an existing trace named '<TraceName>'.

Suffix:

<Trc> Trace number. This suffix is ignored; the trace is referenced by its name.

Query parameters:

<TraceName> Trace name, e.g. 'Ch2Trc2'.

Example: See [CONFigure:TRACe:CATalog?](#)

Usage: Query only

Manual operation: See ["New Channel"](#) on page 427

CONFigure:TRACe<Trc>:CHANnel:NAME:ID? <TraceName>

Queries the channel number (numeric suffix) for an existing trace named '<TraceName>'.

Suffix:
 <Trc> Trace number. This suffix is ignored; the trace is referenced by its name.

Query parameters:
 <TraceName> Trace name, e.g. 'Ch2Trc2'.

Example: See [CONFigure:TRACe:CATalog?](#)

Usage: Query only

Manual operation: See "New Channel" on page 427

CONFigure:TRACe<Trc>:NAME <TraceName>

Assigns a name to an existing trace number <Trc>. Note that it is not possible to assign the same name to two different traces. [CONFigure:TRACe:CATalog?](#) returns a list of all traces in the active recall set with their names.

Suffix:
 <Trc> Number of an existing trace.

Parameters:
 <TraceName> Trace name, e.g. 'Ch2Trc2'.
 *RST: 'Trc1'

Example: See [CONFigure:TRACe:CATalog?](#)

CONFigure:TRACe<Trc>:NAME:ID? <TraceName>

Queries the trace number (numeric suffix) of a trace with known trace name. [CONFigure:TRACe:CATalog?](#) returns a list of all traces in the active recall set with their names.

Suffix:
 <Trc> Trace number. This suffix is not relevant and may be omitted (the command returns the actual trace number).

Query parameters:
 <TraceName> Trace name, e.g. 'Ch2Trc2'.

Example: See [CONFigure:TRACe:CATalog?](#)

Usage: Query only

CONFigure:TRACe<Trc>:REName <OldTraceName>, <NewTraceName>

Assigns a new name to a trace. The trace does not have to be the active trace.

Suffix:
 <Trc> Trace number. This suffix is ignored; the trace is identified via its <TraceName>

Setting parameters:

<OldTraceName> String parameter with old trace name, e.g. 'Trc1'
 <NewTraceName> String parameter with new trace name, e.g. 'S11 Trace'
 *RST: n/a

Example: See `CONFigure:CHANnel<Ch>:TRACe:REName`

Usage: Setting only

Manual operation: See "Table Area" on page 268

8.3.3 CONTrol Commands

The `Control...` commands allow you to configure the following interfaces:

- USER PORT
- Handler I/O connector (Universal Interface, option R&S ZN-B14).

<code>CONTrol:AUXiliary:C[:DATA]</code>	792
<code>CONTrol:HANDler:A[:DATA]</code>	793
<code>CONTrol:HANDler:B[:DATA]</code>	793
<code>CONTrol:HANDler:C[:DATA]</code>	793
<code>CONTrol:HANDler:D[:DATA]</code>	793
<code>CONTrol:HANDler:E[:DATA]</code>	793
<code>CONTrol:HANDler:F[:DATA]</code>	793
<code>CONTrol:HANDler:G[:DATA]</code>	793
<code>CONTrol:HANDler:H[:DATA]</code>	793
<code>CONTrol:HANDler:A:MODE</code>	794
<code>CONTrol:HANDler:B:MODE</code>	794
<code>CONTrol:HANDler:C:MODE</code>	794
<code>CONTrol:HANDler:D:MODE</code>	794
<code>CONTrol:HANDler[:EXTension]:INDex:STATe</code>	794
<code>CONTrol:HANDler[:EXTension]:RTRigger:STATe</code>	795
<code>CONTrol:HANDler:INPut?</code>	795
<code>CONTrol:HANDler:LOGic</code>	795
<code>CONTrol:HANDler:OUTPut<Pt>:USER</code>	796
<code>CONTrol:HANDler:OUTPut<Pt>[:DATA]</code>	796
<code>CONTrol:HANDler:PASSfail:LOGic</code>	797
<code>CONTrol:HANDler:PASSfail:MODE</code>	797
<code>CONTrol:HANDler:PASSfail:POLicy</code>	798
<code>CONTrol:HANDler:PASSfail:SCOPE</code>	798
<code>CONTrol:HANDler:PASSfail:STATus?</code>	799
<code>CONTrol:HANDler:RESet</code>	799
<code>CONTrol:HANDler:SWEpend</code>	799

CONTRol:AUXiliary:C[:DATA] <DecValue>

Sets or queries a channel-dependent eight-bit decimal value to control eight independent output signals at the USER PORT connector (lines 8, 9, 10, 11 and lines 16, 17, 18, 19). The output signals are 3.3 V TTL signals which can be used to differentiate between up to 255 independent analyzer states. `CONTRol:AUXiliary:C[:DATA]` itself does not change the analyzer state.

Channel bit definition and activation

The channel bits have the following properties:

- After a `*RST` of the analyzer all channel bits (including the value for the active, sweeping channel no. 1) are set to zero; no signal is applied to pins 8 to 11 and 16 to 19 of the USER PORT connector.
- The value defined with `CONTRol:AUXiliary:C[:DATA]` is assigned to the **active** channel (`INSTrument:NSElect <Ch>`).
- The signals at the USER PORT connector reflect the channel bits of the **measuring** channel, i.e. the channel for which the analyzer performs a sweep. This channel is not necessarily identical with the active channel.
- The signals are switched on as soon as a measurement (sweep) in a channel with non-zero channel bits is started. They are changed whenever a channel with different channel bits becomes the measuring channel.
- The signals at the USER PORT connector are maintained after the analyzer enters the hold state. This happens if all channels use single sweep mode and if all sweep sequences have been terminated.
- Pins 16 to 19 may be reserved for monitoring the drive ports 1 to 4 of the analyzer (`OUTPut:UPORt:ECBits OFF`). This leaves up to 16 different monitored channel states.

Tip: A simple application consists of selecting the channel numbers as parameters for `CONTRol:AUXiliary:C[:DATA]` and monitor the activity of up to 255 different channels at the USER PORT connector; see example below. You can also use the USER PORT output signals as channel-dependent trigger signals for external devices. Use `OUTPut<Ch>:UPORt[:VALue]` to transfer the eight bit value for an arbitrary channel `<Ch>` in binary representation.

Parameters:

<code><DecValue></code>	Decimal value. The values correspond to the following states of the USER PORT connector:
	0 - no signal at any of the no signal at any of the eight pins 8, 9, 10, 11, 16, 17, 18, 19
	1 - output signal at pin 8
	2 - output signal at pin 9
	3 - output signal at pins 8 and 9
	...
	255 - output signal at pins 8, 9, 10, 11, 16, 17, 18, 19
	Range: 0 to 255
	*RST: 0 (no signal)

Example:

```
*RST; :CONT:AUX:C 1
```

Assign the channel bit value 1 to the active channel no. 1. The analyzer performs a measurement in channel no. 1, therefore the output signal at pin 8 is switched on.

```
CONF:CHAN2:STAT ON; :CONT:AUX:C 2
```

Create channel no. 2, causing it to become the active channel, and assign the channel bit value 2. The analyzer performs no measurement in channel no. 2, therefore the output signal is not changed.

```
CALC2:PAR:SDEF 'Ch2Tr1', 'S11'
```

Create a trace named 'Ch2Tr1' and assign it to channel 2. While the analyzer measures in channel 2, the output signal changes from pin 8 to pin 9.

Manual operation: See "[Optional Columns](#)" on page 364

CONTrol:HANDler:A[:DATA] <DecValue>

CONTrol:HANDler:B[:DATA] <DecValue>

CONTrol:HANDler:C[:DATA] <DecValue>

CONTrol:HANDler:D[:DATA] <DecValue>

CONTrol:HANDler:E[:DATA] <DecValue>

CONTrol:HANDler:F[:DATA] <DecValue>

CONTrol:HANDler:G[:DATA] <DecValue>

CONTrol:HANDler:H[:DATA] <DecValue>

The setting commands write data to ports A, B, C, D, E, F, G, H. To write data to a port, the port must be configured as an output port (see example). By default, the port lines have negative logic: A "0" at a pin corresponds to a high signal, a "1" to a low signal.

The logic can be changed using [CONTrol:HANDler:LOGic POSitive](#). When writing to port G, port C must be configured as an output port. When writing to port H, port C and port D must be configured as output ports (see [CONTrol:HANDler:D:MODE](#)).

The queries read data from ports A, B, C, D, E, F, G, H. If the port is an output port, the queries return the last value that was written to the port.

Parameters:

<DecValue>

Decimal representation for an n-bit binary value. The ranges are:

Port A: 0 to 255 (pins A7 ... A0)

Port B: 0 to 255 (pins B7 ... B0)

Port C: 0 to 15 (pins C3 ... C0)

Port D: 0 to 15 (pins D3 ... D0)

Port E: 0 to 255 (pins D3 ... D0 C3 ... C0)

Port F: 0 to 65535 (pins B7 ... B0 A7 ... A0)

Port G: 0 to 1048575 (pins C3 ... C0 B7 ... B0 A7 ... A0)

Port H: 0 to 16777215 (pins D3 ... D0 C3 ... C0 B7 ... B0 A7 ... A0)

The parameters `MIN`, `MAX`, `DEF` are not supported.

Note: *RST or "Preset" do not change the configuration of the Universal Interface. Use [CONTrol:HANDler:RESet](#) to restore default values.

*RST: n/a (default: 0 (port A, B, and F); ports C, D, and E are configured as input ports.)

Example:

```
CONT:HAND:A:MODE OUTP
Configure port A as an output port.
CONT:HAND:A 192
Write data to port A.
CONT:HAND:B:MODE INP
Configure port B as an input port.
CONT:HAND:B?
Read data from port B.
```

CONTrol:HANDler:A:MODE <Mode>
CONTrol:HANDler:B:MODE <Mode>
CONTrol:HANDler:C:MODE <Mode>
CONTrol:HANDler:D:MODE <Mode>

Controls the direction of the data flow at ports A, B, C, D. The direction at the combined ports E, F, G, H is according to the configuration at the other ports.

Parameters:

<Mode>

INPut | OUTPut

INPut – Input of data at the port

OUTPut – Output of data at the port

Note: *RST or "Preset" do not change the configuration of the Universal Interface. Use [CONTrol:HANDler:RESet](#) to restore default values.

*RST: n/a (default: Port A and B: OUTPut (also valid for port F); port C and D: INPut (also valid for port E). Ports G and H have mixed default modes.)

Example:

See [CONTrol:HANDler:A\[:DATA\]](#)

CONTrol:HANDler[:EXTension]:INDEX:STATE <Boolean>

Selects the digital signal that is routed to pin 20 of the Universal Interface connector.

Parameters:

<Boolean>

ON - /INDEX signal at pin 20

OFF - /PORT_B6 signal at pin 20

*RST: n/a (default: OFF)

Note: *RST or "Preset" do not change the configuration of the Universal Interface. Use [CONTrol:HANDler:RESet](#) to restore default values.

Example: `CONT:HAND:EXT:IND:STAT ON`
 Route the /INDEX signal to pin 20.
 `CONT:HAND:EXT:RTR:STAT ON`
 Route the /READY_FOR_TRIGGER signal to pin 21.
 `CONT:HAND:RES`
 Restore the default state: Pins no. 20 and 21 are available for port B input/output signals.

CONTrol:HANDler[:EXTension]:RTRigger:STATe <Boolean>

Selects the digital signal that is routed to pin 21 of the Universal Interface connector.

Parameters:

<Boolean> `ON` - /READY_FOR_TRIGGER
 `OFF` - /PORT_B7 signal at pin 21
Note: *RST or "Preset" do not change the configuration of the Universal Interface. Use `CONTrol:HANDler:RESet` to restore default values.
 *RST: n/a (default: OFF)

Example: See `CONTrol:HANDler[:EXTension]:INDEX:STATe`

CONTrol:HANDler:INPut?

Queries whether a high to low transition occurred at the /INPUT 1 line (pin 2) of the Universal Interface since the last `CONTrol:HANDler:INPut?` query. The query resets the counter to zero.

A negative pulse fed to this line also causes the /OUTPUT 1 and /OUTPUT 2 lines (pins 3 and 4) to change to low.

Return values:

<NumberOfTrans> `0`, if no transition was detected since last query
 `1`, if one or more transitions were detected.

Example: `CONTrol:HANDler:INPut?`
 Query whether a high to low transition occurred.

Usage: Query only

CONTrol:HANDler:LOGic <Logic>

Selects the logic of the data ports A to H of the Universal Interface. For output ports, a change in logic reverses the state of the output lines immediately. For input ports, a change in logic will be reflected next time when data is read.

Parameters:

<Logic> POSitive | NEGative
 POSitive – 0 = low, 1 = high
 NEGative – 0 = high, 1 = low
Note: *RST or "Preset" do not change the configuration of the Universal Interface. Use [CONTrol:HANDler:RESet](#) to restore default values.
 *RST: n/a (default: NEGative)

Example:

CONTrol:HANDler:LOGic POS
 Change the logic of the data ports to positive.

CONTrol:HANDler:OUTPut<Pt>:USER <BinValue>

Defines the state of the output ports (pin 3 or 4) of the Universal Interface connector after the next negative pulse on the /INPUT1 line (pin 2).

Suffix:

<Pt> Output port number:
 1 - /OUTPUT1 (pin 3)
 2 - /OUTPUT2 (pin 4)
 The parameters MIN, MAX, DEF are not supported.
Note: *RST or "Preset" do not change the configuration of the Universal Interface. Use [CONTrol:HANDler:RESet](#) to restore default values.

Parameters:

<BinValue> 0 - high 1 - low
 *RST: n/a (default: 0)

Example:

See [CONTrol:HANDler:OUTPut<Pt>\[:DATA\]](#)

CONTrol:HANDler:OUTPut<Pt>[:DATA] <BinValue>

Writes a 0 or 1 to the output ports (pin 3 or 4) of the Universal Interface connector. The port lines have negative logic: A "0" corresponds to a high signal, a "1" to a low signal.

The query reads the last value that has been written to the output port.

Suffix:

<Pt> Output port number:
 1 - /OUTPUT1 (pin 3)
 2 - /OUTPUT2 (pin 4)
 The parameters MIN, MAX, DEF are not supported.
Note: *RST or "Preset" do not change the configuration of the Universal Interface. Use [CONTrol:HANDler:RESet](#) to restore default values.

Parameters:

<BinValue> 0 - high
 1 - low
 *RST: n/a (default: 0)

Example:

```
CONT:HAND:OUTP2:DATA 0
Set the /OUTPUT2 line (pin 4) to 0 (current state of /
OUTPUT2).
CONT:HAND:OUTP2:USER 1
Define the next state of the /OUTPUT2 line as 1 (low). /
OUTPUT2 will go from 0 to 1 when the analyzer receives a neg-
ative pulse on the /INPUT1 line (pin 2).
```

CONTrol:HANDler:PASSfail:LOGic <Logic>

Specifies the the logic of the /PASS FAIL line (pin 33) of the Universal Interface.

Parameters:

<Logic> POSitive | NEGative
 POSitive – high meas PASS, low means FAIL
 NEGative – low meas PASS, high means FAIL
Note: *RST or "Preset" do not change the configuration of the
 Universal Interface. Use [CONTrol:HANDler:RESet](#) to restore
 default values.
 *RST: n/a (default: POSitive)

Example:

See [CONTrol:HANDler:PASSfail:MODE](#)

CONTrol:HANDler:PASSfail:MODE <Mode>

Specifies the default logical pass/fail state and the timing of the /PASS FAIL line (pin 33). The /PASS FAIL STROBE (pin 36) is set after the /PASS FAIL line; see [Chapter 11.3.4.4, "Timing of Control Signals"](#), on page 1168.

If the mode is PASS or FAIL, the /PASS FAIL line is returned to its default state when the analyzer is ready for a new measurement (/READY FOR TRIGGER).

Parameters:

<Mode> NOWait | PASS | FAIL
 NOWait – the /PASS FAIL line is set as soon as a failure condi-
 tion occurs.
 PASS – the line stays in PASS state (as defined by [CONTrol:
 HANDler:PASSfail:LOGic](#)) until a sweep end condition
 (determined by [CONTrol:HANDler:PASSfail:SCOPE](#))
 occurs.
 FAIL – the line stays in FAIL state until a sweep end condition
 occurs.
Note: *RST or "Preset" do not change the configuration of the
 Universal Interface. Use [CONTrol:HANDler:RESet](#) to restore
 default values.

*RST: n/a (default: NOWait)

Example:

Configure the /SWEEP END (pin 34) and /PASS FAIL (pin 33) signals:

```
CONTRol:HANDler:SWEEpend GLOBal
```

Set the /SWEEP END line to low when all sweeps in all channels are complete.

```
CONTRol:HANDler:PASSFail:MODE PASS
```

Set the default state of the /PASS FAIL line to PASS.

```
CONTRol:HANDler:PASSFail:SCOPE GLOBal
```

Set the /PASS FAIL line when all sweeps in all channels are complete.

```
CONTRol:HANDler:PASSFail:LOGic POSitive
```

Set the /PASS FAIL line to positive logic.

```
CONTRol:HANDler:PASSFail:POLicy ALLTests
```

Return pass only if all tests pass.

CONTRol:HANDler:PASSfail:POLicy <Policy>

Specifies how the global pass/fail status ([CONTRol:HANDler:PASSfail:STATus?](#) on page 799) is calculated.

Parameters:

<Policy>

ALLTests | ALLMeas

ALLTests – the status is PASS if all limit checks in all measurements (traces) pass.

ALLMeas – the status is PASS if a limit check is defined for all measurements (traces) and all limit checks pass. It is FAIL if one or more traces have no associated limit check, or if at least one limit check fails.

Note: *RST or "Preset" do not change the configuration of the Universal Interface. Use [CONTRol:HANDler:RESet](#) to restore default values.

Example:

See [CONTRol:HANDler:PASSfail:MODE](#)

CONTRol:HANDler:PASSfail:SCOPE <Scope>

Specifies the "sweep end" condition that will cause the /PASS FAIL line (pin 33) to report the status of the global limit check.

Note: This setting is not valid if the pass/fail mode is NOWait ([CONTRol:HANDler:PASSfail:MODE](#) NOWait).

Parameters:

<Scope> GLOBal | CHANnel
 CHANnel – when all the sweeps for each channel are complete
 GLOBal – when all sweeps in all channels are complete
Note: *RST or "Preset" do not change the configuration of the Universal Interface. Use `CONTrol:HANDler:RESet` to restore default values.
 *RST: n/a (default: GLOBal)

Example:

See `CONTrol:HANDler:PASSfail:MODE`

CONTrol:HANDler:PASSfail:STATus?

Returns the global pass/fail status of the last measurement.

Return values:

<Status> PASS | FAIL | NONE
 PASS – all measurements that are not in single sweep mode (on hold) have been swept, and all limit checks have been passed.
 FAIL – all measurements that are not in single sweep mode (on hold) have been swept, at least one limit check failed according to the specified pass/fail policy (`CONTrol:HANDler:PASSfail:POLicy`).
 NONE – no pass/fail status available, e.g. because the measurement is in progress or because no limit check has been defined.
 *RST: n/a

Example:

Preparations: Configure and enable a limit check. Start a measurement and wait until the sweep is complete.
`CONTrol:HANDler:PASSfail:STATus?`
 Query the result of the global limit check.

Usage:

Query only

CONTrol:HANDler:RESet

Restores the default states of the `CONTrol:HANDler...` commands including the data port values.

Example:

See `CONTrol:HANDler[:EXTension]:INDEX:STATe`

Usage:

Event

CONTrol:HANDler:SWEepend <SweepEnd>

Specifies the event that will cause the /SWEEP END line (pin 34) to go low; see [Chapter 11.3.4.4, "Timing of Control Signals"](#), on page 1168.

Parameters:

<SweepEnd> SWEep | CHANnel | GLOBal

SWEep – every time a sweep is complete

CHANnel – when all the sweeps for each channel are complete

GLOBal – when all sweeps in all channels are complete

Note: *RST or "Preset" do not change the configuration of the Universal Interface. Use `CONTrol:HANDler:RESet` to restore default values.

*RST: n/a (default: GLOBal)

Example: See `CONTrol:HANDler:PASSfail:MODE`

8.3.4 DIAGnostic Commands

The `DIAGnostic...` commands provide access to service and diagnostic routines used in service, maintenance and repair. In accordance with the SCPI standard, all commands are device-specific.

Service functions are password-protected (`SYSTEM:PASSword[:CENable]`) and are intended for Rohde & Schwarz service staff. Refer to the service manual for more information.

<code>DIAGnostic:DEvice:STATe</code>	800
<code>DIAGnostic:DUMP:SIZE</code>	801
<code>DIAGnostic:PRODuct:OPTion:INFO?</code>	801
<code>DIAGnostic:SERVice:RFPower</code>	801
<code>DIAGnostic:SERVice:SFUNction</code>	801

`DIAGnostic:DEvice:STATe` <Filename>

Generates a system report and writes it to the specified file. See [Chapter 10.3, "Collecting Information for Technical Support"](#), on page 1146.

Setting parameters:

<Filename> String parameter containing the file name. If no path is specified, the file is stored to the directory
`C:\Users\Public\Documents\Vna\Report`; the extension `*.zip` is appended automatically.
 *RST: n/a

Example: `DIAG:DEV:STAT 'report_16032011_1120'`
 Generate a report and store it to
`C:\Users\Public\Documents\Vna\Report\report_16032011_1120`. Use the `MMEMory...` commands to rename, move, or delete the file.

Usage: Setting only

Manual operation: See ["Save..."](#) on page 533

DIAGnostic:DUMP:SIZE <DumpSize>

Determines the level of detail and hence the size of the dump files created in case of firmware exceptions.

Parameters:

<DumpSize> NONE | MINI | NORMAl | LARGe | FULL
Either disables dump file creation (NONE) or determines the level of detail.

Manual operation: See "[Error Dump Type](#)" on page 527

DIAGnostic:PRODUct:OPTion:INFO? <Option>, <Detail>

Queries a property of an installed software option, identified by its name.

Query parameters:

<Option> Option name, e.g. 'ZND-K2'.
<Detail> DESCription | TYPE | ACTivation | EXPIration | KEY
You can query for an option's DESCription, its KEY and key TYPE, and its ACTivation and EXPIration date (if applicable).

Example: DIAGnostic:PRODUct:OPTion:INFO? 'ZND-K2',DESC
On a R&S ZND this returns 'Time Domain Analysis' (if installed).

Usage: Query only

Manual operation: See "[Software Option Info](#)" on page 535

DIAGnostic:SERVice:RFPower <Boolean>

Turns the internal source power at all ports on or off. This command is equivalent to [OUTPut<Ch>\[:STATe\]](#) .

Parameters:

<Boolean> ON | OFF - switch the power on or off.
*RST: ON

Example: DIAG:SERV:RFP OFF
Turn off the RF source power.

DIAGnostic:SERVice:SFUNction <SFIdentifier>

Calls a service function (mainly for internal use).

- Use [SYSTem:PASSword\[:CENable\]](#) to activate the required service level.
- Use the query form to read back the data returned by the service function.

Parameters:

<SFIdentifier>

Service function in "dotted textual" (example: 'sw.common.memory_usage') or "dotted decimal" (example: '0.1.18.0') representation.

Example:

```
DIAGnostic:SERvice:SFUNction?
'sw.common.memory_usage'
```

This is an "Info Level" service function, i.e. it is not password-protected. It returns the current memory usage of the analyzer firmware.

Manual operation: See "[Service Function](#)" on page 538

8.3.5 DISPLAY Commands

The DISPLAY... commands control the selection and presentation of graphical and trace information on the screen.

**Trace display**

Traces are identified by a string parameter defining the trace name (e.g. `CALCulate<Ch>:PARAmeter:SElect <TraceName>`). In the DISPLAY... subsystem, traces are assigned to diagrams (`DISPlay[:WINDow<Wnd>]:TRACe<WndTr>:FEED <TraceName>`). While this assignment is valid, the trace is identified by the numeric suffix <Wnd>, and the trace name is not needed.

Units for DISPLAY... commands

The DISPLAY... subsystem contains commands to define particular points in the diagram, e.g. to set the scale or a reference value. Some settings require a numeric value and a physical unit, depending on the related parameter type. The following table lists the physical units accepted by the analyzer.

Parameter type	Physical unit
Power	DBM, DB, DBW, W, MW, UW, NW, PW
Voltage	V, MV, UV, NV, PV, DBV, DBMV, DBUV
Phase	DEG, KDEG, MDEG, UDEG, NDEG, PDEG
Group delay	S, MS, US, NS, PS
Impedance	OHM, GOHM, MOHM, KOHM
Admittance	SIE, MSIE, USIE, NSIE
Inductance	H, MH, UH, NH, PH, FH
Capacitance	F, MF, UF, NF, PF, FF
Dimensionless	UNIT, MUNIT, UUNIT, NUNIT, PUNIT, FUNIT

DISPlay: WINDow[:STATe].....	804
DISPlay: WINDow:BFILter[:STATe].....	804
DISPlay: WINDow:MARKer<Mk>[:STATe].....	804
DISPlay[:WINDow<Wnd>][:STATe].....	804
DISPlay[:WINDow<Wnd>]:CATalog?	805
DISPlay[:WINDow<Wnd>]:MAXimize.....	805
DISPlay[:WINDow<Wnd>]:OVERview[:STATe].....	806
DISPlay[:WINDow<Wnd>]:NAME.....	806
DISPlay[:WINDow<Wnd>]:TITLe[:STATe].....	807
DISPlay[:WINDow<Wnd>]:TITLe:DATA.....	807
DISPlay[:WINDow<Wnd>]:TRACe<WndTr>:CATalog?	807
DISPlay[:WINDow<Wnd>]:TRACe<WndTr>:DELeTe.....	808
DISPlay[:WINDow<Wnd>]:TRACe<WndTr>:EFEeD.....	808
DISPlay[:WINDow<Wnd>]:TRACe<WndTr>:FEED.....	809
DISPlay[:WINDow<Wnd>]:TRACe<WndTr>:LABel:SHOW.....	809
DISPlay[:WINDow<Wnd>]:TRACe<WndTr>:SHOW.....	810
DISPlay[:WINDow<Wnd>]:TRACe<WndTr>:X:OFFSet.....	811
DISPlay[:WINDow<Wnd>]:TRACe<WndTr>:Y[:SCALe]:AUTO.....	811
DISPlay[:WINDow<Wnd>]:TRACe<WndTr>:Y[:SCALe]:BOTTom.....	812
DISPlay[:WINDow<Wnd>]:TRACe<WndTr>:Y[:SCALe]:TOP.....	812
DISPlay[:WINDow<Wnd>]:TRACe<WndTr>:Y[:SCALe]:PDIVision.....	813
DISPlay[:WINDow<Wnd>]:TRACe<WndTr>:Y[:SCALe]:RLEVel.....	814
DISPlay[:WINDow<Wnd>]:TRACe<WndTr>:Y[:SCALe]:RPOSition.....	815
DISPlay[:WINDow<Wnd>]:TRACe<WndTr>:Y:OFFSet.....	816
DISPlay[:WINDow<Wnd>]:TRACe<WndTr>:ZOOM[:STATe].....	817
DISPlay[:WINDow<Wnd>]:TRACe<WndTr>:ZOOM:START.....	818
DISPlay[:WINDow<Wnd>]:TRACe<WndTr>:ZOOM:STOP.....	818
DISPlay[:WINDow<Wnd>]:TRACe<WndTr>:ZOOM:BOTTom.....	818
DISPlay[:WINDow<Wnd>]:TRACe<WndTr>:ZOOM:TOP.....	818
DISPlay:ANNotation:CHANnel[:STATe].....	819
DISPlay:ANNotation:TRACe[:STATe].....	819
DISPlay:ANNotation:FREQuency[:STATe].....	819
DISPlay:CMAP:LIMit:FCOLorize[:STATe].....	819
DISPlay:CMAP:LIMit:FSYMBOL[:STATe].....	820
DISPlay:CMAP:LIMit[:STATe].....	820
DISPlay:CMAP:MARKer[:STATe].....	820
DISPlay:CMAP<DispEl>:RGB.....	821
DISPlay:CMAP:TRACe:COLor[:STATe].....	822
DISPlay:CMAP:TRACe:RGB.....	823
DISPlay:LAYout.....	824
DISPlay:LAYout:APPLy.....	824
DISPlay:LAYout:DEFine.....	824
DISPlay:LAYout:EXECute.....	825
DISPlay:LAYout:GRID.....	826
DISPlay:LAYout:JOIN.....	826
DISPlay:MENU:KEY:ACTion:CATalog?	827
DISPlay:MENU:KEY:EXECute.....	827
DISPlay:MENU:KEY:SELect.....	827
DISPlay:MENU:KEY:TOOL:CATalog?	828
DISPlay:RFSize.....	828

DISPlay:IWINDow[:STATe] <Boolean>

Shows/hides the [Info Window](#)

Parameters:

<Boolean> 0 – hide the "Info Window" (default)
 1 – show the "Info Window"

Manual operation: See "[Info Window](#)" on page 511

DISPlay:IWINDow:BFILter[:STATe] <TraceName>, <BandfilterItem>, <Boolean>

Defines the bandfilter search results to be displayed in the [Info Window](#).

Parameters:

<Boolean> 0 – Result <BandfilterItem> of trace <TraceName> is displayed
 1 – Result <BandfilterItem> of trace <TraceName> is hidden

Setting parameters:

<TraceName> Name of the related trace.
 <BandfilterItem> CENTER | BANDwidth | UPPer | LOWer | LOSS | QFActor |
 QFA3 | HEADer
 Bandfilter search result (see [Display Elements of a Diagram](#))

Manual operation: See "[Content Selection](#)" on page 515

DISPlay:IWINDow:MARKer<Mk>[:STATe] <TraceName>, <Boolean>

Defines the markers to be displayed in the [Info Window](#).

Suffix:

<Mk> Marker number.

Parameters:

<Boolean> 0 – Marker <Mk> of trace <TraceName> is displayed
 1 – Marker <Mk> of trace <TraceName> is hidden

Setting parameters:

<TraceName> Name of the related trace.

Manual operation: See "[Content Selection](#)" on page 515

DISPlay[:WINDow<Wnd>][:STATe] <Boolean>

Creates or deletes a diagram area, identified by its area number <Wnd>.

Suffix:

<Wnd> Number of the diagram area to be created or deleted.

Parameters:

<Boolean> ON | OFF - creates or deletes diagram area no. <Wnd>.
 *RST: -

Example: `CALC4:PAR:SDEF 'Ch4Tr1', 'S11'`
 Create channel 4 and a trace named Ch4Tr1 to measure the input reflection coefficient S_{11} .
`DISP:WIND2:STAT ON`
 Create diagram area no. 2.
`DISP:WIND2:TRAC9:FEED 'CH4TR1'`
 Display the generated trace in diagram area no. 2, assigning the trace number 9 to it.

Manual operation: See ["Add Tr+Diag"](#) on page 266

DISPlay[:WINDow<Wnd>]:CATalog?

Returns the numbers and names of all diagrams in the current recall set.

The response is a string containing a comma-separated list of diagram area numbers and names, see example below. If all diagram areas have been deleted, the response is an empty string ("").

Suffix:

<Wnd> Number of a diagram. This suffix is ignored; the command returns a list of all diagrams.

Example: `*RST; :DISP:WIND2:STAT ON`
 Create diagram no. 2.
`DISP:WIND2:NAME 'S11 Test Diagram'`
 Assign a name to the new diagram.
`DISP:CAT?`
 Query all diagrams and their names. As a default diagram no. 1 is created upon *RST, the response is `'1,1,2,S11 Test Diagram'`. The first diagram is not named; its default name is equal to the diagram number.
`CALC:PAR:SDEF 'Win2_Tr1', 'S11'`
 Create a trace named Win2_Tr1 to measure the input reflection coefficient S_{11} .
`DISP:WIND2:TRAC9:FEED 'Win2_Tr1'`
 Display the generated trace in diagram area no. 2, assigning the trace number 9 to it.
`DISP:WIND2:TRAC:CAT?`
 Query all traces in diagram area no. 2. The response is `'9,Win2_Tr1'`.

Usage: Query only

Manual operation: See ["Title"](#) on page 505

DISPlay[:WINDow<Wnd>]:MAXimize <Boolean>

Maximizes all diagram areas in the active recall set or restores the previous display configuration.

Suffix:
 <Wnd> Number of the diagram area to become the active diagram area. `DISPlay:WINDow<Wnd>:MAXimize` acts on all diagrams of the current recall set, however, the diagram no. <Wnd> is displayed on top of the others.

Parameters:
 <Boolean> ON | OFF - maximize all diagram areas or restore the previous display configuration.
 *RST: OFF

Example: *RST; :DISP:WIND2:STAT ON
 Create diagram areas no. 1 (with default trace) and 2 (with no trace).
 DISP:WIND2:MAXimize ON
 Maximize the diagram areas, placing area no. 2 on top.

Manual operation: See ["Maximize Diagram"](#) on page 505

DISPlay[:WINDow<Wnd>]:OVERview[:STATe] <Boolean>

Enables the zoom function with an additional overview window for the diagram no. <Wnd> or removes the overview window from a diagram.

Suffix:
 <Wnd> Number of the zoomed diagram area

Parameters:
 <Boolean> ON – activate the zoom window with overview window
 OFF – remove the overview window
 *RST: OFF

Example: See `DISPlay[:WINDow<Wnd>]:TRACe<WndTr>:ZOOM[:STATe]`

DISPlay[:WINDow<Wnd>]:NAME <Name>

Defines a name for diagram area <Wnd>. The name appears in the list of diagram areas, to be queried by `DISPlay[:WINDow<Wnd>]:CATalog?`.

Suffix:
 <Wnd> Number of the diagram area.

Parameters:
 <Name> String variable for the name.

Example: See `DISPlay[:WINDow<Wnd>]:CATalog?`

Manual operation: See ["Title"](#) on page 505

DISPlay[:WINDow<Wnd>]:TITLe[:STATe] <Boolean>

Displays or hides the title for area number <Wnd>, defined by means of
DISPlay:WINDow<Wnd>:TITLe:DATA.

Suffix:

<Wnd> Number of the diagram area.

Parameters:

<Boolean> ON | OFF - displays or hides the title.
*RST: ON

Example: See [DISPlay\[:WINDow<Wnd>\]:TITLe:DATA](#)

Manual operation: See ["Show Title"](#) on page 505

DISPlay[:WINDow<Wnd>]:TITLe:DATA <Title>

Defines a title for diagram area <Wnd>.

Suffix:

<Wnd> Number of the diagram area.

Parameters:

<Title> String variable for the title. The length of the title is practically unlimited but should be kept short enough to be displayed in the diagrams.

Example: *RST; :DISP:WIND:TITL:DATA 'S21 Test Diagram'
Define a title for the default diagram area. The title is displayed below the top of the diagram area.
DISP:WIND:TITL OFF; TITL:DATA?
Hide the title. The title is no longer displayed but still defined so it can be displayed again.

Manual operation: See ["Title"](#) on page 505

DISPlay[:WINDow<Wnd>]:TRACe<WndTr>:CATalog?

Returns the numbers and names of all traces in diagram area no. <Wnd>.

Suffix:

<Wnd> Number of a diagram area.

<WndTr> Trace number used to distinguish the traces of the same diagram area <Wnd>. This suffix is ignored; the command returns a list of all traces.

Example: See [DISPlay\[:WINDow<Wnd>\]:CATalog?](#)

Usage: Query only

Manual operation: See ["Active Diagram"](#) on page 504

DISPlay[:WINDow<Wnd>]:TRACe<WndTr>:DELeTe

Releases the assignment between a trace and a diagram area, as defined by means of `DISPlay[:WINDow<Wnd>]:TRACe<WndTr>:FEED <TraceName>` and expressed by the `<WndTr>` suffix. The trace itself is not deleted; this must be done via `CALCulate<Ch>:PARAmeter:DELeTe <TraceName>`.

Suffix:

`<Wnd>` Number of an existing diagram area (defined by means of `DISPlay[:WINDow<Wnd>][:STATE] ON`).

`<WndTr>` Trace number used to distinguish the traces of the same diagram area `<Wnd>`.

Example:

```
CALC4:PAR:SDEF 'Ch4Tr1', 'S11'
```

Create channel 4 and a trace named Ch4Tr1 to measure the input reflection coefficient S_{11} .

```
DISP:WIND2:STAT ON
```

Create diagram area no. 2.

```
DISP:WIND2:TRAC9:FEED 'CH4TR1'
```

Display the generated trace in diagram area no. 2, assigning the trace number 9 to it.

```
DISP:WIND2:TRAC9:DELeTe
```

Release the assignment between trace no. 9 and window no. 2. The trace can still be referenced with its trace name Ch4Tr1.

Usage: Event

DISPlay[:WINDow<Wnd>]:TRACe<WndTr>:EFEEd <TraceName>

Assigns an existing trace (`CALCulate<Ch>:PARAmeter:SDEFine <TraceName>`) to a diagram area `<Wnd>`, and displays the trace. Use `DISPlay[:WINDow<Wnd>]:TRACe<WndTr>:FEED` to assign the trace to a diagram area using a numeric suffix (e.g. in order to use the `DISPlay[:WINDow<Wnd>]:TRACe<WndTr>:Y:OFFSet` command).

Tip: You can open the "Trace Manager" dialog to obtain an overview of all channels and traces, including the traces that are not displayed.

Suffix:

`<Wnd>` Number of an existing diagram area (defined by means of `DISPlay[:WINDow<Wnd>][:STATE] ON`).

`<WndTr>` Trace number. This suffix is ignored; the trace is referenced by its name.

Setting parameters:

`<TraceName>` String parameter for the trace name, e.g. 'Trc4'.

Example: `CALC4:PAR:SDEF 'Ch4Tr1', 'S11'`
 Create channel 4 and a trace named Ch4Tr1 to measure the
 input reflection coefficient S_{11} .
 `DISP:WIND2:STAT ON`
 Create diagram area no. 2.
 `DISP:WIND2:TRAC:EFE 'CH4TR1'`
 Display the generated trace in diagram area no. 2. No trace
 number is assigned.

Usage: Setting only

DISPlay[:WINDow<Wnd>]:TRACe<WndTr>:FEED <TraceName>

Assigns an existing trace (`CALCulate<Ch>:PARAmeter:SDEFine`) to a diagram area, using the `<WndTr>` suffix, and displays the trace. Use `DISPlay[:WINDow<Wnd>]:TRACe<WndTr>:EFEed` to assign the trace to a diagram area without using a numeric suffix.

Tip: A trace can be assigned to a diagram only once. If a attempt is made to assign the same trace a second time (e.g. by typing `DISP:WIND2:TRAC8:FEED 'CH4TR1'` after executing the program example below) an error message -114,"Header suffix out of range" is generated. You can open the "Trace Manager" dialog to obtain an overview of all channels and traces, including the traces that are not displayed.

Suffix:

`<Wnd>` Number of an existing diagram area (defined by means of `DISPlay[:WINDow<Wnd>][:STATe] ON`).

`<WndTr>` Trace number used to distinguish the traces of the same diagram area `<Wnd>`.

Parameters:

`<TraceName>` String parameter for the trace name, e.g. 'Trc4'.

Example: `CALC4:PAR:SDEF 'Ch4Tr1', 'S11'`
 Create channel 4 and a trace named Ch4Tr1 to measure the
 input reflection coefficient S_{11} .
 `DISP:WIND2:STAT ON`
 Create diagram area no. 2.
 `DISP:WIND2:TRAC9:FEED 'CH4TR1'`
 Display the generated trace in diagram area no. 2, assigning the
 trace number 9 to it.

Manual operation: See ["Add Trace"](#) on page 265

DISPlay[:WINDow<Wnd>]:TRACe<WndTr>:LABel:SHOW <TraceName>[, <Boolean>]

Displays or hides the label of an existing trace, identified by its `<TraceName>`.

Suffix:

`<Wnd>` ignored

<WndTr> ignored

Parameters:

<TraceName> Trace name (string parameter), e.g. 'Trc4'

<Boolean> ON | OFF – display or hide the label of the related trace

Example:

```
*RST; :DISP:TRAC:LAB:SHOW? 'Trc1'
```

Reset the analyzer, creating the default trace 'Trc1'. The trace label is displayed; the query returns 1.

```
DISP:TRAC:LAB:SHOW 'Trc1', OFF
```

Hide the label of trace 'Trc1'.

Manual operation: See "[Table Area](#)" on page 268

DISPlay[:WINDow<Wnd>]:TRACe<WndTr>:SHOW <TraceName>[, <Boolean>]

Displays or hides an existing trace, identified by its trace name <Trace_Name>, or a group of traces.

Tip: You can open the trace manager to obtain an overview of all channels and traces, including the traces that are not displayed.

Suffix:

<Wnd> Number of a diagram area. This suffix is ignored; the command affects traces in all diagram areas.

<WndTr> Trace number. This suffix is ignored; the trace is referenced by its name.

Parameters:

<TraceName> DALL – all data traces
MALL – all memory traces
<string> – single trace identified by its trace name (string parameter), e.g. 'Trc4'.

<Boolean> ON | OFF – display or hide traces.

Example:

```
*RST; :DISP:TRAC:SHOW? 'Trc1'
```

Reset the analyzer, creating the default trace 'Trc1'. The trace is displayed; the query returns 1.

```
CALC4:PAR:SDEF 'Ch4Tr1', 'S11'
```

Create channel 4 and a trace named Ch4Tr1 to measure the input reflection coefficient S_{11} .

```
DISP:WIND2:STAT ON; :DISP:WIND2:TRAC:FEED  
'CH4TR1'
```

Create diagram area no. 2 and display the generated trace in the diagram area.

```
DISP:TRAC:SHOW DALL, OFF
```

Hide both traces in both diagrams.

```
DISP:TRAC:SHOW? DALL
```

Query whether all data traces are displayed. The response 0 means that at least one trace is hidden.

Manual operation: See "[Table Area](#)" on page 268

DISPlay[:WINDow<Wnd>]:TRACe<WndTr>:X:OFFSet <StimulusOffset>

Shifts the trace <WndTr> in horizontal direction, leaving the positions of all markers unchanged.

Suffix:

<Wnd> Number of an existing diagram area (defined by means of [DISPlay\[:WINDow<Wnd>\]\[:STATe\] ON](#)).

<WndTr> Existing trace number, assigned by means of [DISPlay\[:WINDow<Wnd>\]:TRACe<WndTr>:FEED](#).

Parameters:

<StimulusOffset> Stimulus offset value.
The range and unit depends on the sweep type.
Default unit: NN

Example:

```
*RST; :DISP:WIND:TRAC:X:OFFS 1MHZ; :DISP:WIND:
TRAC:Y:OFFS 10
Create the default trace and shift it horizontally by 1 MHz, verti-
cally by 10 dB.
```

Manual operation: See "[Stimulus](#)" on page 294

DISPlay[:WINDow<Wnd>]:TRACe<WndTr>:Y[:SCALE]:AUTO <Activate>[, <TraceName>]

Displays the entire trace in the diagram area, leaving an appropriate display margin. The trace can be referenced either by its number <WndTr> or by its name <TraceName>.

Suffix:

<Wnd> Number of an existing diagram area (defined by means of [DISPlay\[:WINDow<Wnd>\]\[:STATe\] ON](#)). This suffix is ignored if the optional <TraceName> parameter is used.

<WndTr> Existing trace number, assigned by means of [DISPlay\[:WINDow<Wnd>\]:TRACe<WndTr>:FEED](#). This suffix is ignored if the optional <TraceName> parameter is used.

Setting parameters:

<Activate> ONCE
Activate the autoscale function.

<TraceName> Optional string parameter for the trace name, e.g. 'Trc4'. If this optional parameter is present, both numeric suffixes are ignored (trace names must be unique across different channels and windows).

Example: `*RST; DISP:WIND:TRAC:Y:PDIV?; RLEV?`
 Query the value between two grid lines and the reference value for the default trace. The response is 10;0.
`DISP:WIND:TRAC:Y:AUTO ONCE; PDIV?; RLEV?`
 or:
`DISP:WIND:TRAC:Y:AUTO ONCE, 'Trc1'; PDIV?;`
`RLEV?`
 Autoscale the default trace and query the scaling parameters again. In general both values have changed.

Usage: Setting only

Manual operation: See "[Auto Scale Trace](#)" on page 260

DISPlay[:WINDow<Wnd>]:TRACe<WndTr>:Y[:SCALE]:BOTTom <LowEdge>[, <TraceName>]

DISPlay[:WINDow<Wnd>]:TRACe<WndTr>:Y[:SCALE]:TOP <UppEdge>[, <TraceName>]

These commands define the lower (bottom) and upper (top) edge of the diagram area <Wnd>.

Suffix:

<Wnd> Number of an existing diagram area (defined by means of [DISPlay\[:WINDow<Wnd>\]\[:STATe\] ON](#)). This suffix is ignored if the optional <TraceName> parameter is used.

<WndTr> Existing trace number, assigned by means of [DISPlay\[:WINDow<Wnd>\]:TRACe<WndTr>:FEED](#). This suffix is ignored if the optional <TraceName> parameter is used.

Parameters:

<UppEdge> Value and unit for the lower or upper diagram edge. Range and unit depend on the measured quantity, see "[Units for DISPlay... commands](#)" on page 802.

Default unit: NN

<TraceName> Optional string parameter for the trace name, e.g. 'Trc4'. If this optional parameter is present, both numeric suffixes are ignored (trace names must be unique across different channels and windows).

Example:

```
CALC4:PAR:SDEF 'Ch4Tr1', 'S11'
```

Create channel 4 and a trace named Ch4Tr1 to measure the input reflection coefficient S_{11} .

```
DISP:WIND2:STAT ON
```

Create diagram area no. 2.

```
DISP:WIND2:TRAC9:FEED 'CH4TR1'
```

Display the generated trace in diagram area no. 2, assigning the trace number 9 to it.

```
DISP:WIND2:TRAC9:Y:BOTT -40; TOP 10
```

or:

```
DISP:WIND2:TRAC:Y:BOTT -40, 'CH4TR1'; TOP 10, 'CH4TR1'
```

Scale the diagram between -40 dB and +10 dB.

Manual operation: See "[Max / Min](#)" on page 261

DISPlay[:WINDow<Wnd>]:TRACe<WndTr>:Y[:SCALE]:PDIVision <VerticalDiv>[, <TraceName>]

Sets the value between two grid lines (value "per division") for the diagram area <Wnd>. When a new PDIVision value is entered, the current RLEVel is kept the same, while the top and bottom scaling is adjusted for the new PDIVision value.

Suffix:

<Wnd>

Number of an existing diagram area (defined by means of [DISPlay\[:WINDow<Wnd>\]\[:STATE\] ON](#)). This suffix is ignored if the optional <TraceName> parameter is used.

<WndTr>

Existing trace number, assigned by means of [DISPlay\[:WINDow<Wnd>\]:TRACe<WndTr>:FEED](#). This suffix is ignored if the optional <TraceName> parameter is used.

Parameters:

<VerticalDiv>

Value and unit for the vertical diagram divisions. Range and unit depend on the measured quantity, see "[Units for DISPlay... commands](#)" on page 802.

Default unit: NN

<TraceName>

Optional string parameter for the trace name, e.g. 'Trc4'. If this optional parameter is present, both numeric suffixes are ignored (trace names must be unique across different channels and windows).

Example:

```
CALC4:PAR:SDEF 'Ch4Tr1', 'S11'
```

Create channel 4 and a trace named Ch4Tr1 to measure the input reflection coefficient S_{11} .

```
DISP:WIND2:STAT ON
```

Create diagram area no. 2.

```
DISP:WIND2:TRAC9:FEED 'CH4TR1'
```

Display the generated trace in diagram area no. 2, assigning the trace number 9 to it.

```
DISP:WIND2:TRAC9:Y:PDIV 5
```

or:

```
DISP:WIND2:TRAC:Y:PDIV 5, 'CH4TR1'
```

Set the value per division to 5 dB.

Manual operation: See ["Scale/Div"](#) on page 260

```
DISPlay[:WINDow<Wnd>]:TRACe<WndTr>:Y[:SCALE]:RLEVel <RefLevel>[,  
  <TraceName>]
```

Sets the reference level (or reference value) for a particular displayed trace. Setting a new reference level does not affect the value of `PDIVision`. The trace can be referenced either by its number `<WndTr>` or by its name `<TraceName>`.

Suffix:

`<Wnd>`

Number of an existing diagram area (defined by means of `DISPlay[:WINDow<Wnd>][:STATE] ON`). This suffix is ignored if the optional `<TraceName>` parameter is used.

`<WndTr>`

Existing trace number, assigned by means of `DISPlay[:WINDow<Wnd>]:TRACe<WndTr>:FEED`. This suffix is ignored if the optional `<TraceName>` parameter is used.

Parameters:

`<RefLevel>`

Value and unit for the reference level (or reference value, if the trace does not show a level). Range and unit depend on the measured quantity, see ["Units for DISPlay... commands"](#) on page 802.

Default unit: NN

`<TraceName>`

Optional string parameter for the trace name, e.g. 'Trc4'. If this optional parameter is present, both numeric suffixes are ignored (trace names must be unique across different channels and windows).

Example:

```
CALC4:PAR:SDEF 'Ch4Tr1', 'S11'
```

Create channel 4 and a trace named Ch4Tr1 to measure the input reflection coefficient S_{11} .

```
DISP:WIND2:STAT ON
```

Create diagram area no. 2.

```
DISP:WIND2:TRAC9:FEED 'CH4TR1'
```

Display the generated trace in diagram area no. 2, assigning the trace number 9 to it.

```
DISP:WIND2:TRAC9:Y:RLEV -10
```

or:

```
DISP:WIND2:TRAC:Y:RLEV -10, 'CH4TR1'
```

Change the reference level to -10 dB.

Manual operation: See ["Ref Value"](#) on page 261

DISPlay[:WINDow<Wnd>]:TRACe<WndTr>:Y[:SCALe]:RPOSition <RefPosition>[, <TraceName>]

Sets the point on the y-axis to be used as the reference position as a percentage of the length of the y-axis. The reference position is the point on the y-axis which should equal the `RLEVEL`.

Suffix:

<Wnd>

Number of an existing diagram area (defined by means of `DISPlay[:WINDow<Wnd>][:STATe] ON`). This suffix is ignored if the optional <TraceName> parameter is used.

<WndTr>

Existing trace number, assigned by means of `DISPlay[:WINDow<Wnd>]:TRACe<WndTr>:FEED`. This suffix is ignored if the optional <TraceName> parameter is used.

Parameters:

<RefPosition>

Value of the reference position in percent. The top of the y-axis is defined to have a reference position of 100%, while the bottom of the y-axis is defined to have a reference position of 0%.

Range: 0% to 100%

*RST: 80%

Default unit: %

<TraceName>

Optional string parameter for the trace name, e.g. 'Trc4'. If this optional parameter is present, both numeric suffixes are ignored (trace names must be unique across different channels and windows).

Example:

```
CALC4:PAR:SDEF 'Ch4Tr1', 'S11'
```

Create channel 4 and a trace named Ch4Tr1 to measure the input reflection coefficient S_{11} .

```
DISP:WIND2:STAT ON
```

Create diagram area no. 2.

```
DISP:WIND2:TRAC9:FEED 'CH4TR1'
```

Display the generated trace in diagram area no. 2, assigning the trace number 9 to it.

```
DISP:WIND2:TRAC9:Y:RPOS 50
```

or:

```
DISP:WIND2:TRAC:Y:RPOS 50, 'CH4TR1'
```

Set the reference position to the center of the diagram area.

Manual operation: See "[Ref Pos](#)" on page 261

```
DISPlay[:WINDow<Wnd>]:TRACe<WndTr>:Y:OFFSet <MagnitudeFactor>[,  
  <PhaseFactor>[, <RealPart>[, <ImaginaryPart>]]]
```

Modifies all points of the trace <WndTr> by means of an added and/or a multiplied complex constant. The response values M of the trace are transformed according to:

Suffix:

<Wnd> Number of an existing diagram area (defined by means of [DISPlay\[:WINDow<Wnd>\]\[:STATe\] ON](#)).

<WndTr> Existing trace number, assigned by means of [DISPlay\[:WINDow<Wnd>\]:TRACe<WndTr>:FEED](#).

Parameters:

<MagnitudeFactor> Multiplied magnitude factor

Range: -300 dB to + 300 dB

*RST: 0 dB

Default unit: dB

<PhaseFactor> Multiplied phase factor, optional for setting command but returned by query

Range: $-3.4 \cdot 10^{38}$ deg to $+3.4 \cdot 10^{38}$ deg

*RST: 0 deg

Default unit: deg

<RealPart> Real and imaginary part of added complex constant, optional for setting command but returned by query

Range: $-3.4 \cdot 10^{38}$ to $+3.4 \cdot 10^{38}$

*RST: 0

<ImaginaryPart>

- Example:** `*RST; :DISP:WIND:TRAC:X:OFFS 1MHZ; :DISP:WIND:TRAC:Y:OFFS 10`
 Create the default trace and shift it horizontally by 1 MHz, vertically by 10 dB.
`DISP:WIND:TRAC:Y:OFFS?`
 Query all response offset values. The response is 10, 0, 0, 0.
- Manual operation:** See "[Mag / Phase / Real / Imag](#)" on page 294

DISPlay[:WINDow<Wnd>]:TRACe<WndTr>:ZOOM[:STATe] <Boolean>[, <TraceName>]

Applies or disables the zoom function based on the current zoom window settings.

Suffix:

<Wnd>

Number of an existing diagram (defined by means of [DISPlay\[:WINDow<Wnd>\]\[:STATe\] ON](#)). This suffix is ignored if the optional <TraceName> parameter is used.

<WndTr>

Existing trace number, assigned by means of [DISPlay\[:WINDow<Wnd>\]:TRACe<WndTr>:FEED](#). This suffix is ignored if the optional <TraceName> parameter is used.

Parameters:

<Boolean>

Enable or disable the zoom. OFF also restores the original diagram size after a zoom function was applied.

OFF

<TraceName>

Optional string parameter for the trace name, e.g. 'Trc4'. If this optional parameter is present, both numeric suffixes are ignored (trace names must be unique across different channels and windows).

Example:

`*RST; :DISPlay:WINDow1:TRACe:ZOOM:BOTTom -20; TOP +10; START 1GHz; STOP 1.5 GHz`

Define a zoom rectangle in the default diagram no. 1 ranging from -20 dB to +10 dB and from 1 GHz to 1.5 GHz.

`DISPlay:WINDow1:TRACe:ZOOM ON`

Zoom into the diagram no. 1 so that the zoom window fills the entire diagram. The actual sweep range and the stimulus values of the sweep points are not affected.

`DISPlay:WINDow1:OVERview:STATe ON`

Activate an additional overview window in the upper part of the diagram.

- Manual operation:** See "[Zoom Select/Stim. Zoom Select](#)" on page 263

```
DISPlay[:WINDow<Wnd>]:TRACe<WndTr>:ZOOM:START <LeftBorder>[,
    <TraceName>]
```

```
DISPlay[:WINDow<Wnd>]:TRACe<WndTr>:ZOOM:STOP <RightBorder>[,
    <TraceName>]
```

These commands specify the start and stop values of the zoom window (left and right border), respectively. In contrast to manual control, all or part of the zoom window may be outside the original diagram. The range of possible values depends on the R&S ZND's frequency range; see [Chapter 8.3.14.10, "\[SENSe:\]FREQuency..."](#), on page 960.

Suffix:

<Wnd> Number of an existing diagram (defined by means of [DISPlay\[:WINDow<Wnd>\]\[:STATe\] ON](#)). This suffix is ignored if the optional <TraceName> parameter is used.

<WndTr> Existing trace number, assigned by means of [DISPlay\[:WINDow<Wnd>\]:TRACe<WndTr>:FEED](#). This suffix is ignored if the optional <TraceName> parameter is used.

Parameters:

<RightBorder> Left or right border of the zoom window.
 Range: See description above.
 *RST: Start or stop of the analyzer's sweep range.
 Default unit: NN

<TraceName> Optional string parameter for the trace name, e.g. 'Trc4'. If this optional parameter is present, both numeric suffixes are ignored (trace names must be unique across different channels and windows).

Example: See [DISPlay\[:WINDow<Wnd>\]:TRACe<WndTr>:ZOOM\[:STATe\]](#)

Manual operation: See "[Max / Min / Start / Stop](#)" on page 264

```
DISPlay[:WINDow<Wnd>]:TRACe<WndTr>:ZOOM:BOTTom <LowEdge>[,
    <TraceName>]
```

```
DISPlay[:WINDow<Wnd>]:TRACe<WndTr>:ZOOM:TOP <UppEdge>[,
    <TraceName>]
```

These commands specify the lower and upper edge of the zoom window. In contrast to manual control, all or part of the zoom window may be outside the original diagram.

Suffix:

<Wnd> Number of an existing diagram (defined by means of [DISPlay\[:WINDow<Wnd>\]\[:STATe\] ON](#)). This suffix is ignored if the optional <TraceName> parameter is used.

<WndTr> Existing trace number, assigned by means of [DISPlay\[:WINDow<Wnd>\]:TRACe<WndTr>:FEED](#). This suffix is ignored if the optional <TraceName> parameter is used.

Parameters:

<UppEdge> Lower or upper edge of the zoom window. Range and unit depend on the measured quantity, see "[Units for DISPLAY... commands](#)" on page 802.

Default unit: NN

<TraceName> Optional string parameter for the trace name, e.g. 'Trc4'. If this optional parameter is present, both numeric suffixes are ignored (trace names must be unique across different channels and windows).

Example: See `DISPlay[:WINDow<Wnd>]:TRACe<WndTr>:ZOOM[:STATe]`

Manual operation: See "[Max / Min / Start / Stop](#)" on page 264

DISPlay:ANNotation:CHANnel[:STATe] <Boolean>

DISPlay:ANNotation:TRACe[:STATe] <Boolean>

Shows or hides the channel/trace list(s) in all diagrams of the current recall set.

Parameters:

<Boolean> ON | OFF - show or hide information element(s).

*RST: ON

Example: `*RST; :DISP:ANN:TRAC OFF; CHAN ON; FREQ OFF`
Create diagram area no. 1 (with default trace) and hide the trace list. Keep the channel list but hide the swept frequency range.

Manual operation: See "[Trace Info](#)" on page 510

DISPlay:ANNotation:FREQuency[:STATe] <Boolean>

Unmasks or masks all stimulus values in the VNA GUI for the active recall set.

Parameters:

<Boolean> ON | OFF - unmask or mask stimulus values

*RST: ON - all stimulus values unmasked

Example: `*RST; :DISP:ANN:FREQ OFF`
Create diagram area no. 1 (with default trace) and mask all stimulus values.

Manual operation: See "[Hide Sensitive Information](#)" on page 510

DISPlay:CMAP:LIMit:FCOLorize[:STATe] <Boolean>

Assigns a different trace color to failed trace segments ("Colorize Trace when Failed").

Parameters:

<Boolean> ON | OFF - colorize trace or keep original trace color.

*RST: n/a (a *RST does not affect the setting). In the factory configuration, OFF is preset.

Example: See `DISPlay:CMAP:LIMit[:STATe]`

Manual operation: See "[Limit Test > Colorize Trace when Failed](#)" on page 512

`DISPlay:CMAP:LIMit:FSYMBOL[:STATe]` <Boolean>

Displays or hides the limit fail symbols (colored squares) on the trace.

Parameters:

<Boolean> ON | OFF - show or hide symbols.
 *RST: n/a (a *RST does not affect the setting). In the factory configuration, ON is preset.

Example: See `DISPlay:CMAP:LIMit[:STATe]`

Manual operation: See "[Limit Test > Show Limit Fail Symbols](#)" on page 512

`DISPlay:CMAP:LIMit[:STATe]` <Boolean>

Displays all limit lines either with individually configured colors or with the color of the associated trace(s). The colors of all display elements are defined via `DISPlay:CMAP<DispEl>:RGB`.

.

Parameters:

<Boolean> ON - the limit line colors are defined via `DISPlay:CMAP<DispEl>:RGB` where <DispEl> = 9 ... 12. The limit line colors are independent of the trace colors.
 OFF - all limit lines have the color of the associated trace.
 *RST: n/a (a *RST does not affect the setting). In the factory configuration, OFF is preset.

Example:

```
DISP:CMAP:LIMit OFF
Use the trace colors for all limit lines associated with each trace.
Subsequent limit line color definitions will be ignored until individual
limit settings are enabled again.
DISPlay:CMAP:LIMit:FCOLORize:STATe ON
Assign a different trace color to failed trace sections.
DISPlay:CMAP:LIMit:FSYMBOL:STATe OFF
Remove the limit fail symbols from the trace.
```

Manual operation: See "[Limit Test > Use Trc Color for Limit Lines](#)" on page 513

`DISPlay:CMAP:MARKer[:STATe]` <Boolean>

Displays all markers with the same color or display each marker with the color of the associated trace. The colors of all display elements are defined via `DISPlay:CMAP<DispEl>:RGB <Red>, <Green>, <Blue> ...`

Parameters:

<Boolean> ON - all markers have the same color, to be defined via `DISPlay:CMAP<DispEl>:RGB <Red>, <Green>, <Blue>`. The marker color is independent of the trace colors.
 OFF - each marker has the color of the associated trace.

Example: See `DISPlay:CMAP<DispEl>:RGB`

Manual operation: See "[General > Same Color all Markers](#)" on page 513

DISPlay:CMAP<DispEl>:RGB <Red>, <Green>, <Blue>[, <TraceStyle>[, <TraceWidth>]]

Defines the user color scheme using the Red/Green/Blue color model. For traces also the line style and width can be defined.

Use `DISPlay:CMAP:TRACe:RGB` to define the properties of a particular trace, referenced by its name.

Suffix:

<DispEl> Number of the display element as described in the table below.

Parameters:

<Red> Red content of the defined color.
 Range: 0 (zero intensity, corresponding to a 0 in the 24-bit color model) to 1 (full intensity, corresponding to 255 in the 24-bit color model).

<Green> Green content of the defined color.
 Range: 0 (zero intensity, corresponding to a 0 in the 24-bit color model) to 1 (full intensity, corresponding to 255 in the 24-bit color model).

<Blue> Blue content of the defined color.
 Range: 0 (zero intensity, corresponding to a 0 in the 24-bit color model) to 1 (full intensity, corresponding to 255 in the 24-bit color model).

<TraceStyle> SOLid | DASHed | DOTTed | DDOTted | DDDotted
 Optional trace style, only for traces (<DispEl> > 12): One of the string parameters SOLid | DASHed | DOTTed | DDOTted | DDDotted.

<TraceWidth> Optional trace width, only for traces (<DispEl> > 12).
 Range: 1 to 20

Example:

```
*RST; :DISP:CMAP:MARK ON; :CALC:MARK ON
```

Create diagram area no. 1 (with default trace showing the S-parameter S_{21}) and a marker M1.

```
CALC:PAR:SDEF 'Trc2', 'S11'
```

```
DISP:WIND:TRAC2:FEED 'TRC2'
```

Create a trace named Trc2 and display the trace in diagram area no. 1. Note that the new trace automatically becomes the active trace.

```
CALC:MARK2 ON
```

Assign a marker M2 to the trace. Both markers are displayed with the same color.

```
DISP:CMAP13:RGB 1,0,0; :DISP:CMAP14:RGB 0,1,0
```

Color the first trace red, the second trace green.

```
DISP:CMAP6:RGB?
```

Query the marker color. The marker color depends on the settings made in previous sessions; it is not reset. A possible response is 0,0,0 for black markers.

```
DISP:CMAP:MARK OFF
```

Change the marker colors: M1 turns red, M2 turns green.

Manual operation: See "[Element](#)" on page 512

The numeric suffixes <DispEl> denote the following display elements:

<DispEl>	Display Element
1	Background
2	Text
3	Selected Text
4	Grid
5	Reference Line
6	Same Color for all Markers
7	Vertical Range Lines
8	Diagram Title
9	Limit Fail Trace Color
10	Limit Line Type Off
11	Limit Line Type Upper
12	Limit Line Type Lower
13 to 12+N	Trace properties 1 to N, where N is the number of trace colors configured using SYSTem:DISPlay:TRACes:CCOUNT

DISPlay:CMAP:TRACe:COLor[:STATe] <Boolean>

Defines the trace color schemes in different diagram areas.

Parameters:

<Boolean> OFF - independent color scheme in new diagram area. Moved traces change their color.
ON - color scheme in new diagram area continues the previous color scheme. Moved traces keep their color.

Example:

```
*RST; :DISP:CMAP13:RGB 1,0,0
```

Create diagram area no. 1 (with default trace showing the S-parameter S_{21}) and color the trace red.

```
DISP:CMAP:TRAC:COL OFF; :DISP:WIND2:STAT ON
```

Select independent color schemes for new diagram areas. Create a new diagram area no. 2.

```
CALC:PAR:SDEF 'Trc2', 'S11'; :DISP:WIND2:TRAC2:FEED 'TRC2'
```

Create a new trace named Trc2 and display the trace in a new diagram area no. 2. The new trace is red like the first trace.

```
DISP:CMAP:TRAC:COL ON; :DISP:WIND3:STAT ON
```

Continue the same color scheme in new diagram areas. Create a new diagram area no. 3.

```
CALC:PAR:SDEF 'Trc3', 'S22'; :DISP:WIND3:TRAC3:FEED 'Trc3'
```

Create a new trace named Trc3 and display the trace in a new diagram area no. 3. The new trace is not red.

Manual operation: See "[General > Trace Colors per Diagram](#)" on page 513

DISPlay:CMAP:TRACe:RGB <TraceName>, <Red>, <Green>, <Blue>[, <TraceStyle>[, <TraceWidth>]]

Defines the color, style and width of a trace referenced by its name, based on the Red/Green/Blue color model. Use the generalized command [DISPlay:CMAP<DispEl>:RGB](#) to define the color of other display elements.

Parameters:

<TraceName>	Trace name, string parameter
<Red>	Red content of the defined color. Range: 0 (zero intensity, corresponding to a 0 in the 24-bit color model) to 1 (full intensity, corresponding to 255 in the 24-bit color model).
<Green>	Green content of the defined color. Range: 0 (zero intensity, corresponding to a 0 in the 24-bit color model) to 1 (full intensity, corresponding to 255 in the 24-bit color model).
<Blue>	Blue content of the defined color. Range: 0 (zero intensity, corresponding to a 0 in the 24-bit color model) to 1 (full intensity, corresponding to 255 in the 24-bit color model).

<TraceStyle> SOLid | DASHed | DOTTed | DDOTted | DDDotted
 Optional trace style, only for traces (<DispEl> > 12): One of the string parameters SOLid | DASHed | DOTTed | DDOTted | DDDotted.

<TraceWidth> Optional trace width, only for traces (<DispEl> > 12).
 Range: 1 to 20

Example: *RST; :DISP:CMAP:TRAC:RGB 'Trc1', 1, 0, 0
 Color the default trace 'Trc1' red.
 See also DISPLAY:CMAP<DispEl>:RGB

Manual operation: See ["Properties"](#) on page 512

DISPlay:LAYout <LayoutMode>

Arranges the diagrams in the screen, leaving the diagram contents unchanged.

Parameters:

<LayoutMode> LINeup | STACK | HORizontal | VERTical | GRID
 LINeup – the diagrams are arranged side by side.
 STACK – the diagrams are arranged one on top of the other.
 HORizontal – the diagrams are arranged in horizontal rows.
 VERTical – the diagrams are arranged in vertical rows.
 GRID – the diagrams are arranged as a rectangular matrix. The number of rows and columns is as defined with command [DISPlay:LAYout:GRID](#).

Example: See [DISPlay:LAYout:GRID](#)

Manual operation: See ["Split Type"](#) on page 508

DISPlay:LAYout:APPLy <LayoutId>

Selects a previously defined layout for display in the analyzer screen.

Parameters:

<LayoutId> Integer value 1, 2 ...
 Current number, as defined by [DISPlay:LAYout:DEFine](#).

Example: See [Creating Diagrams](#)

Manual operation: See ["Additional Functionality: SCPI Commands"](#) on page 508

DISPlay:LAYout:DEFine <LayoutId>, <LayoutFormatMode>, <LayoutData>

DISPlay:LAYout:DEFine? <LayoutId>

Creates a horizontal or vertical display layout and provides it with an identifier (<LayoutId>).

Layouts are defined row by row (horizontal layouts) or column by column (vertical layouts).

- A horizontal layout consists of N rows, each of height h_i ($i = 1$ to N). The heights are defined in units relative to the total height of the screen, i.e. their sum $h_1 + h_2 + \dots + h_N$ must be equal to 1.00.
Each row contains a selectable number of diagrams with independent widths w_{ij} ($j = 1, 2 \dots M(i)$). The sum of the widths in each row must also match the screen width, hence $w_{i1} + w_{i2} + \dots + w_{iM(i)} = 1.00$ for all rows ($i = 1$ to N).
The `<LayoutData>` string for horizontal layouts reads ' $h_1, w_{11}, w_{12} \dots w_{1M(1)}; h_2, w_{21}, w_{22} \dots w_{2M(2)}; \dots; h_N, w_{N1}, w_{N2} \dots w_{NM(N)}$ '.
A semicolon separates different rows, a comma separates different diagram widths within a row.
- The definition of a vertical layout is analogous, however, the role of rows and columns is interchanged.

The query returns the layout data in an alternative, executable format. The executable format is also used by `DISPlay:LAYout:EXECute`.

Use `DISPlay:LAYout:JOIN` or `DISPlay:LAYout:EXECute` to create more complicated (nested) layouts.

Note: The maximum number of diagrams in a layout is 256.

Parameters:

`<LayoutFormatMode>` `HORizontal` | `VERTical`

Horizontal or vertical layout; see above.

`<LayoutData>`

String parameter defining the number of diagrams and their position (easy format); see above.

Parameters for setting and query:

`<LayoutId>`

Integer value 1, 2 ...

Current number, used by other `DISPlay:LAYout...` commands to reference the created layout.

Example:

See [Creating Diagrams](#)

Manual operation: See "[Additional Functionality: SCPI Commands](#)" on page 508

DISPlay:LAYout:EXECute `<LayoutData>`

Creates and displays a horizontal or vertical display layout. The query returns the layout data of the currently displayed layout (the last layout selected via `DISPlay:LAYout:APPLY`) in executable format.

The executable format is an extension of the easy format used by `DISPlay:LAYout:DEFine`.

- The `<LayoutData>` string consists of two parts: `<LayoutData> = '(<StartFormat>, <RepeatFormat1>, <RepeatFormat2> ...)`. The `<StartFormat>` descriptor distinguishes between horizontal and vertical layouts and defines the number of rows or columns. A `<RepeatFormat>` descriptor follows for each row or column in the lay-

out. The <RepeatFormat> descriptors can be nested in order to describe joined layouts; refer to [Creating Diagrams](#) for an easy example.

- For a horizontal layout with N rows, each of height h_i ($i = 1 \dots N$) and filled with $M(i)$ diagrams with independent widths w_{ij} ($j = 1, 2 \dots M(i)$), the data string is composed as follows:
 <StartFormat> = N,1,0.00,0.00
 <RepeatFormat_i> = (1,M(i),1.00, h_i [w_{i1} ,1.00], [w_{i2} ,1.00] ... [$w_{iM(i)}$,1.00])
- For a vertical layout with N columns, each of width w_i ($i = 1 \dots N$) and filled with $M(i)$ diagrams with independent heights h_{ij} ($j = 1, 2 \dots M(i)$), the data string is composed as follows:
 <StartFormat> = 1,N,0.00,0.00
 <RepeatFormat_i> = (M(i),1, w_i ,1.00,[1.00, h_{i1}], [1.00, h_{i2}] ... [1.00, $h_{iM(i)}$])

Note: The maximum number of diagrams in a layout is 256.

Parameters:

<LayoutData> String parameter defining the number of diagrams and their position (executable format); see above.

Example: See [Creating Diagrams](#)

Manual operation: See "[Additional Functionality: SCPI Commands](#)" on page 508

DISPlay:LAYout:GRID <Rows>, <Columns>

Defines the number of rows and columns if `DISPlay:LAYout GRID` is set.

Parameters:

<Rows> Range: 1 to 16
 *RST: 1

<Columns> Range: 1 to 16
 *RST: 1

Example:

`DISPlay:LAYout GRID`
 Select te split type where the diagrams are arranged in rows and columns.
`DISPlay:LAYout:GRID 2,2`
 Arrange 4 diagrams in two rows and two columns.

Manual operation: See "[Diagrams / Rows / Columns](#)" on page 508

DISPlay:LAYout:JOIN <MainLayoutId>, <DiagramNumber>, <SubLayoutId>

Creates a nested layout, inserting a sub-layout into one of the diagrams of a main layout. Main layout and sub-layout must be defined previously, preferably using [DISPlay:LAYout:DEFine](#).

Note: The maximum number of joined levels within a layout is 16.

Setting parameters:

<MainLayoutId>	Integer value 1, 2 ... Current number of main layout, as defined by DISPlay:LAYout:DEFine .
<DiagramNumber>	Integer value 1, 2 ... Diagram number in the main layout
<SubLayoutId>	Integer value 1, 2 ... Current number of sub-layout, as defined by DISPlay:LAYout:DEFine .
*RST:	n/a

Example: See [Creating Diagrams](#)

Usage: Setting only

Manual operation: See "[Additional Functionality: SCPI Commands](#)" on page 508

DISPlay:MENU:KEY:ACTion:CATalog?

Displays the identifiers of the available dialog opener actions as a comma-separated list of strings.

Use [DISPlay:MENU:KEY:EXECute](#) to open one of the dialogs.

Usage: Query only

DISPlay:MENU:KEY:EXECute <MenuKey>

Opens the dialog identified by <MenuKey>.

Use [DISPlay:MENU:KEY:ACTion:CATalog?](#) to display the available opener IDs.

Note that no error is generated if a valid <MenuKey> is specified but the dialog cannot be opened for any other reason.

Setting parameters:

<MenuKey>	Identifier of a dialog opener
-----------	-------------------------------

Example: *RST; DISP:MENU:KEY:EXECute ':Cal:Management:CalConnectorTypes'
Activates the [Cal Connector Types Dialog](#).

Usage: Setting only

Tip: When working with the [GPIB Explorer](#), switch to raw mode ("Options > Raw mode" in the IECWIN32 GUI) before executing this command.

DISPlay:MENU:KEY:SElect <MenuKey>

Activates the softtool tab with identifier <MenuKey>.

Use [DISPlay:MENU:KEY:TOOL:CATalog?](#) to display the available identifiers.

Note that no error is generated if a valid <MenuKey> is specified but the tab cannot be activated for any other reason.

Setting parameters:

<MenuKey> Identifier of a softtool tab

Example: *RST; DISP:MENU:KEY:SEL ':Meas:SParams'
Activates the "S-Params" tab of the "Meas" softtool.

Usage: Setting only

Tip: When working with the [GPIB Explorer](#), switch to raw mode ("Options > Raw mode" in the IECWIN32 GUI) before executing this command.

DISPlay:MENU:KEY:TOOL:CATalog?

Displays the identifiers of the available softtool tabs as a comma-separated list of strings.

Use [DISPlay:MENU:KEY:SElect](#) to activate one of the tabs.

Usage: Query only

DISPlay:RFSize <RelFontSize>

Defines the size of the fonts in the diagram on a relative scale.

Parameters:

<RelFontSize> Relative font size
Range: 80 % to 170 %
*RST: 100 %
Default unit: percent

Example: *RST; :DISP:RFS 80
Use smaller fonts to gain more space for the traces in the diagram.

Manual operation: See ["Font Size"](#) on page 511

8.3.6 FORMat Commands

The `FORMAT...` commands select a data format for transferring numeric data (including arrays) from and to the analyzer.

FORMat[:DATA]	828
FORMat:BORDER	829

FORMat[:DATA] <TransferFormat>[, <Length>]

Selects the format for numeric data transferred to and from the analyzer.

Note: The format setting is only valid for commands and queries whose description states that the response is formatted as described by `FORMat[:DATA]`. In particular, it affects trace data transferred by means of the commands in the `TRACe:...` system.

Parameters:

`<TransferFormat>` ASCII | REAL

ASCII - numeric data is transferred as ASCII bytes. The numbers are separated by commas as specified in IEEE 488.2.
 REAL - Data is transferred in a definite length block as IEEE floating point numbers of the specified `<Length>`. See [Chapter 7.2.3.5, "Block Data Format"](#), on page 571.

Note: If binary data is transferred to the analyzer, the receive terminator should be set to EOI (`SYSTEM:COMMunicate:GPIB[:SELF]:RTERminator EOI`) to avoid inadvertent interruption of the data transfer.

`<Length>` The optional `<Length>` parameter is needed for REAL format only. It defines the length of the floating point numbers in bits. Valid values are 32 and 64.

*RST: ASCII. The default length of REAL data is 32 bits (single precision).

Example:

```
FORM REAL, 32
Select real data format.
SYST:COMM:GPIB:RTER EOI
Set the terminator to EOI.
(During a calibration) ... CORR:CDAT?
'REFLTRACK',1,0
```

Query a system error correction term. The data is transferred in a definite length block which can be written to a file; the analyzer displays the message "<no> bytes binary data received".

FORMat:BORDER `<ByteOrder>`

Controls whether binary data is transferred in normal or swapped byte order.

Parameters:

`<ByteOrder>` NORMAL | SWAPped

NORMAL - the most significant byte is transferred first (big endian).
 SWAPped - the least significant byte is transferred first (little endian).

*RST: SWAPped (if the GPIB Language is set to PNA or HP xxxx, then the order is NORMAL)

Example:

```
FORM:BORD NORM
Change the byte order to normal mode.
```

Manual operation: See "[Define *IDN + *OPT...](#)" on page 540

8.3.7 HCOPY Commands

The `HCOPY...` commands control the output of screen information to an external device. Part of the functionality of this system is included in the "File" menu.

<code>HCOPY[:IMMEDIATE]</code>	830
<code>HCOPY:DESTINATION</code>	830
<code>HCOPY:DEVICE:LANGUAGE</code>	831
<code>HCOPY:ITEM:ALL</code>	831
<code>HCOPY:ITEM:LOGO[:STATE]</code>	831
<code>HCOPY:ITEM:MLIST[:STATE]</code>	832
<code>HCOPY:ITEM:TIME[:STATE]</code>	832
<code>HCOPY:PAGE:COLOR</code>	832
<code>HCOPY:PAGE:MARGIN:BOTTOM</code>	833
<code>HCOPY:PAGE:MARGIN:LEFT</code>	833
<code>HCOPY:PAGE:MARGIN:RIGHT</code>	834
<code>HCOPY:PAGE:MARGIN:TOP</code>	834
<code>HCOPY:PAGE:ORIENTATION</code>	834
<code>HCOPY:PAGE:WINDOW</code>	834

HCOPY[:IMMEDIATE]

Initializes the print according to the current `HCOPY...` configuration.

Example:

```
HCOP:DEST '<Printer_name>'
Select the printer for the output of screen data.
HCOP
Start printing.
```

Usage: Event

Manual operation: See "Print" on page 490

HCOPY:DESTINATION <PrinterName>

Selects a printer name or file as destination for the screen output.

Parameters:

<PrinterName> String variable containing the printer name. One of the printers accessible from your PC. The following strings are supported in addition:

- 'MMEM' - print to file. The file name is defined via `MMEMORY:NAME`. The command `HCOPY:DEVICE:LANGUAGE` selects the file format.
- 'DEFPRT' - use default printer, to be selected in the "Devices and Printers" dialog of the Windows control panel. (Windows 7: "Printers and Faxes".)

*RST: n/a (*RST does not overwrite the printer destination)

Example: `MMEM:NAME 'C:\Screenshots\PLOT1.BMP'`
 Define a printer file name (without creating the file), assuming that .BMP is the current file format (see [HCOPY:DEVICE:LANGUage](#)).
`HCOP:DEST 'MMEM'; :HCOP`
 Select 'Print to file' and create the printer file specified before.

Manual operation: See "To File..." on page 490

HCOPY:DEVIce:LANGUage <Format>

Selects a file format for printer files. Selecting the format is recommended to ensure that the file defined via [MMEMoRY:NAME](#) can be read or imported by an external application.

Parameters:

<Format> BMP | PNG | JPG | PDF | SVG
 BMP - Windows bitmap
 JPG - JPEG bitmap
 PNG - portable network graphics format
 PDF - portable document format (Adobe® Systems)
 SVG - scalable vector graphics format, XML-based
 *RST: n/a (*RST does not affect the printer configuration)

Example: `HCOP:DEV:LANG BMP`
 Select Windows bitmap format for printer files.
`MMEM:NAME 'C:\Screenshots\PLOT1.BMP'`
 Define a printer file name and specify an existing directory (without creating the file).
`HCOP:DEST 'MMEM'; :HCOP`
 Select 'Print to file' and create the printer file specified before.

HCOPY:ITEM:ALL

Selects the complete screen contents to be printed, including the logo ([HCOPY:ITEM:LOGO\[:STATe\]](#)), time ([HCOPY:ITEM:TIME\[:STATe\]](#)), and the marker list ([HCOPY:ITEM:MLIST\[:STATe\]](#)).

Example: `HCOP:ITEM:ALL`
 Select the complete information to be printed.
`HCOP`
 Start printing.

Usage: Event

HCOPY:ITEM:LOGO[:STATe] <Boolean>

Qualifies whether or not the printed output contains the logo. The default R&S logo (file `Logo.gif`) is stored in the `Resources\Images` subdirectory of the VNA program directory and can be replaced by another logo.

Parameters:

<Boolean> ON | OFF - logo is included or excluded.
 *RST: n/a (*RST does not affect the printer configuration)

Example:

```
HCOP:ITEM:ALL
Select the complete information to be printed.
HCOP:ITEM:LOGO ON; :HCOP
Include the logo in the printed output and start printing.
```

HCOPy:ITEM:MLIST[:STATe] <Boolean>

Qualifies whether or not the printed output contains the information in the marker info field (marker list).

Parameters:

<Boolean> ON | OFF - marker list is included or excluded.
 *RST: n/a (*RST does not affect the printer configuration)

Example:

```
HCOP:ITEM:ALL
Select the complete information to be printed.
HCOP:ITEM:MLIST ON; :HCOP
Include the marker list in the printed output and start printing.
```

HCOPy:ITEM:TIME[:STATe] <Boolean>

Qualifies whether or not the printed output contains the current date and time.

Parameters:

<Boolean> ON | OFF - date and time is included or excluded.
 *RST: n/a (*RST does not affect the printer configuration)

Example:

```
HCOP:ITEM:ALL
Select the complete information to be printed.
HCOP:ITEM:TIME ON; :HCOP
Include the data and time in the printed output and start printing .
```

HCOPy:PAGE:COLor <ColorScheme>

Select the color scheme to be used for printing.

Parameters:

<ColorScheme> UDEFined | DBACKground | LBACKground | BWLStyles | BWSolid | PBWLstyles | PCLBackgrnd | ON | OFF
 ON – print with color or grayscale (depending on the printer capabilities).
 OFF – use black-and-white printing using line styles to allow identification of different traces.

UDEFined

User defined color scheme, previously configured using
 DISPlay:CMAP:* commands

DBACKground

Dark background

LBACKground

Light background

BWLStyles

Black and white with white background and different line styles

BWSolid

Black and white with white background and black solid lines

PBWLstyles

Printer optimized black and white with different line styles

PCLBackgrnd

Printer optimized color scheme with light background

ON | OFF

For compatibility with previous versions of this command: ON = PCLBackgrnd, OFF = PBWLstyles

*RST: n/a (*RST does not affect the printer configuration)

Example:`HCOP:PAGE:COL UDEF`

Select the user-defined color scheme

Manual operation: See ["Print Options"](#) on page 492**HCOPy:PAGE:MARGin:BOTTom <LowMargin>**

Defines the distance between the bottom of the page and the bottom of the printed information.

Parameters:

<LowMargin>

Lower margin

Range: 0.01 mm to 10000 mm

*RST: n/a (*RST does not affect the printer configuration)

Example:`HCOP:PAGE:MARG:BOT 10; TOP 10`

Set an upper and a lower margin of 1 cm.

HCOPy:PAGE:MARGin:LEFT <LeftMargin>

Defines the distance between the left edge of the page and the left edge of the printed information.

Parameters:

<LeftMargin>

Left margin

Range: 0.01 mm to 10000 mm

*RST: n/a (*RST does not affect the printer configuration)

Example:`HCOP:PAGE:MARG:LEFT 10; RIGHT 10`

Set an left and a right margin of 1 cm.

HCOPY:PAGE:MARGin:RIGHT <RightMargin>

Defines the distance between the right edge of the page and the right edge of the printed information.

Parameters:

<RightMargin> Right margin
 Range: 0.01 mm to 10000 mm
 *RST: n/a (*RST does not affect the printer configuration)

Example:

HCOPY:PAGE:MARG:LEFT 10; RIGHT 10
 Set an left and a right margin of 1 cm.

HCOPY:PAGE:MARGin:TOP <UppMargin>

Defines the distance between the top of the page and the top of the printed information.

Parameters:

<UppMargin> Upper margin
 Range: 0.01 mm to 10000 mm
 *RST: n/a (*RST does not affect the printer configuration)

Example:

HCOPY:PAGE:MARG:BOTT 10; TOP 10
 Set an upper and a lower margin of 1 cm.

HCOPY:PAGE:ORientation <Orientation>

Defines the orientation of the printed page. Switching between LANDscape and PORTrait rotates the hardcopy result by 90 degrees. No other settings are changed.

Parameters:

<Orientation> LANDscape | PORTrait
 LANDscape - long edge of the paper is the top of the page.
 PORTrait - short edge of the paper is the top of the page.
 *RST: n/a (*RST does not affect the printer configuration)

Example:

HCOPY:PAGE:ORI LAND; :HCOPY
 Select landscape page orientation and start printing.

HCOPY:PAGE:WINDow <PrintDiagram>

Defines how the diagrams shall be printed (using [HCOPY\[:IMMediate\]](#)).

Parameters:

<PrintDiagram> ALL | SINGLE | ACTIVE | HARDcopy | NONE
 ALL - all diagrams are printed on one page.
 SINGLE - one diagram per page.
 ACTIVE - print only active diagram.
 HARDcopy - print a screenshot of the diagram area, preserving layout and colors ("real screenshot")

NONE - print no diagram at all.

*RST: n/a (*RST does not affect the printer configuration)

Example:

HCOP:PAGE:WIND SING; :HCOP

Select one diagram per page and start printing.

8.3.8 INITiate Commands

The `INITiate...` commands control the initiation of the trigger system and define the scope of the triggered measurement.

<code>INITiate[:IMMEDIATE]:ALL</code>	835
<code>INITiate:CONTinuous:ALL</code>	835
<code>INITiate:PIPelining:STATe</code>	836
<code>INITiate<Ch>[:IMMEDIATE][:DUMMy]</code>	836
<code>INITiate<Ch>[:IMMEDIATE]:SCOPE</code>	836
<code>INITiate<Ch>:CONTinuous</code>	837

INITiate[:IMMEDIATE]:ALL

Starts a new single sweep sequence in all channels. This command is available in single sweep mode only (`INITiate:CONTinuous:ALL OFF`). The data of the last sweep (or of previous sweeps, see [Retrieving the Results of Previous Sweeps](#)) can be read using `CALCulate<Chn>:DATA:NSweep:FIRSt? SDATa, <count>`.

This command is not supported in the "ZVR" or "ZVABT" compatibility modes.

Note: In contrast to all other commands of the analyzer, the `INITiate<Ch>[:IMMEDIATE]...` commands have been implemented for overlapped execution; see [Chapter 7.4, "Command Processing"](#), on page 576.

Example: See `INITiate<Ch>:CONTinuous`

Usage: Event

Manual operation: See ["Restart Sweep"](#) on page 371

INITiate:CONTinuous:ALL <Boolean>

Qualifies whether the analyzer measures in single sweep or in continuous sweep mode.

This command is not supported in the "ZVR" or "ZVABT" compatibility modes.

Parameters:

<Boolean> ON - the analyzer measures continuously in all channel, repeating the current sweep. The query returns ON (1) if at least one channel is measured continuously.
 OFF - the measurement is stopped after the number of sweeps defined via `[SENSe<Ch>:]SWEep:COUNT`. `INITiate<Ch>[:IMMEDIATE][:DUMMy]` initiates a new measurement cycle.

*RST: ON

- Example:** See `INITiate<Ch>:CONTinuous`
- Manual operation:** See "All Channels Continuous/All Channels on Hold" on page 372

`INITiate:PIPeLining:STATe <Mode>`

Allows you to activate [pipelining of measurement data](#) for the alternated driving mode (`[SENSE<Ch>:]COUple NONE | AUTO`).

Parameters:

- `<Mode>` OFF | CHANnel
- OFF**
No pipelining (default)
- CHANnel**
Pipeline enabled for alternated driving mode

Manual operation: See "Pipelining" on page 373

`INITiate<Ch>[:IMMediate][:DUMMy]`

Starts a new single sweep sequence. This command is available in single sweep mode only (`INITiate<Ch>:CONTinuous OFF`). The data of the last sweep (or previous sweeps, see [Chapter 9.2.4.3, "Retrieving the Results of Previous Sweeps"](#), on page 1133) can be read using `CALCulate<Chn>:DATA:NSweep:FIRSt? SDATa, <count>`.

Note: In contrast to all other commands of the analyzer, the `INITiate<Ch>[:IMMediate] . . .` commands have been implemented for overlapped execution; see [Chapter 7.4, "Command Processing"](#), on page 576.

Suffix:

- `<Ch>` Channel number. If the channel number does not exist the analyzer returns an error message. If the "ZVR" or "ZVABT" compatibility mode is active and `INITiate<Ch>[:IMMediate]:SCOPE ALL` is selected, this suffix is ignored.

Example: See `INITiate<Ch>:CONTinuous`

Usage: Event

Manual operation: See "Restart Sweep" on page 371

`INITiate<Ch>[:IMMediate]:SCOPE <Scope>`

Selects the scope of the single sweep sequence. The setting is applied in single sweep mode only (`INITiate<Ch>:CONTinuous OFF`).

This command is required in compatibility modes only (see [SYSTEM:LANGUage](#)).

Suffix:

- `<Ch>` Channel number

Parameters:

<Scope> ALL | SINGLE

`INITiate<Ch>[:IMMediate][:DUMMy]` starts a single sweep in all channels or in the referenced channel <Ch> only.

Example:

See `INITiate<Ch>:CONTinuous`

Manual operation: See "[Sweep All Channels/Sweeps](#)" on page 373

INITiate<Ch>:CONTinuous <Boolean>

Qualifies whether the analyzer measures in single sweep or in continuous sweep mode.

Suffix:

<Ch> Channel number.
This suffix is ignored in the "ZVR" and "ZVABT" compatibility modes (`SYSTem:LANGuage 'ZVR' | 'ZVABT'`).

Parameters:

<Boolean> ON - the analyzer measures continuously, repeating the current sweep.

OFF - the measurement is stopped after the number of sweeps defined via `[SENSe<Ch>:]SWEep:COUNT`. `INITiate<Ch>[:IMMediate][:DUMMy]` initiates a new measurement cycle.

*RST: ON

Example:

```
*RST; :CALC2:PAR:SDEF 'TRC2','S11'
DISPlay:WINDow:TRACe2:FEED 'Trc2'
```

Reset the analyzer to create the default channel no. 1 and default trace. Create a second trace and display the trace. Both traces are measured continuously.

```
INIT1:CONT OFF
```

Activate single sweep mode for the first channel. The measurement in channel no. 1 is stopped after the current sweep. Channel no. 2 is still measured continuously.

```
INIT1
```

Activate a new (single) sweep in channel no. 1. Channel no. 2 is still measured continuously.

```
INIT:CONT:ALL OFF
```

Activate single sweep mode for all channels. The measurement in channel no. 2 is also stopped after the current sweep.

```
INIT:ALL
```

Re-start a single sweep in both channels.

Example: Alternative settings using the R&S ZVAB compatibility mode:
`*RST; :SYSTEM:LANGUage 'ZVABT'`
`*RST; :INIT:CONT OFF`
 Activate single sweep mode for all channels (including channel no. 2 created later).
`INIT:SCOP SING`
 State that a single sweep will be performed in the active channel.
`CALC2:PAR:SDEF 'TRC2','S11'; :INIT2`
 Create channel no. 2 with a new trace and start a single sweep in channel no. 2. Start a single sweep in the second channel.

Manual operation: See "[Continuous / Single](#)" on page 370

8.3.9 INSTRument Commands

The `INSTRument...` commands select or query particular resources (SCPI: logical instruments) of the analyzer.

<code>INSTRument:NSElect</code>	838
<code>INSTRument:PORT:COUNT?</code>	838
<code>INSTRument:SMATrix</code>	839
<code>INSTRument:TPORt:COUNT?</code>	839

`INSTRument:NSElect` <Channel>

Selects a channel as the active channel.

Parameters:

<Channel> Number of the channel to be activated. The channel must be created before using `CONFigure:CHANnel<Ch>[:STATe] ON`.
 Range: 1, 2, ...
 *RST: 1

Example: `CONF:CHAN2:STAT ON; :INST:NSEL?`
 Create channel no. 2 and select it as the active channel. The query returns 2.

`INSTRument:PORT:COUNT?`

Returns the number of test ports (Port 1, Port 2 ...) of the analyzer.

Example: `INST:PORT:COUN?`
 Return the number of ports of your analyzer.

Usage: Query only

INSTRument:SMATrix <Boolean>

In "set direction" this command performs a default setup or "clear" of the switch matrix RF connections; in "get direction" it queries whether at least one RF connection to a switch matrix is configured.

Parameters:

<Boolean>

ON | 1 (setting) – adds all registered switch matrices to the RF configuration, performing a default assignment of VNA ports and test ports.

OFF | 0 (setting) – removes all switch matrices from the RF configuration

1 (query) – at least one RF connection to a switch matrix

0 (query) – no RF connection to a switch matrix

Example:

See [SYSTem:COMMunicate:RDEvice:SMATrix:CONFigure:START](#)

INSTRument:TPORt:COUNT?

Returns the total number of test ports.

In absence of switch matrices, i.e. if no RF connection to a switch matrix is configured, this is identical to the number of VNA ports (see [INSTRument:PORT:COUNT?](#)).

With switch matrices, the return value is the total number of matrix test ports.

Usage: Query only

8.3.10 MEMory

The `MEMory...` commands control the loaded recall sets of the analyzer.

**Storing setups**

The `MEMory...` commands do not affect any stored files. Use the `MMEMory...` commands to store and load data and to manage files stored on a mass storage device.

MEMory:CATalog?	839
MEMory:CATalog:COUNT?	840
MEMory:DEFine	840
MEMory:DELeTe[:NAME]	840
MEMory:DELeTe:ALL	840
MEMory:SELeCt	841

MEMory:CATalog?

Returns the names of all loaded recall sets.

Example: *RST; :MEM:DEF 'SET_2'
 Create a recall set named 'Set_2' and make it the active recall set.
 MEM:CAT?
 Query all recall sets. The response is 'Set1,SET_2'.
 MMEM:STOR:STAT 1, 'C:\Users\Public\Documents\Rohde-Schwarz\Vna\RecallSets\Set_2.znx'
 MEM:DEL 'Set_2.znx'
 Store the active recall set "Set_2" to a file, renaming it "Set_2.znx". Close the setup.

Usage: Query only

MEMory:CATalog:COUNT?

Returns the number of loaded recall sets.

Usage: Query only

MEMory:DEFine <Name>

Creates a new recall set<Name> using default settings for the traces, channels and diagram areas. The created recall set becomes the active recall set.

Setting parameters:

<Name> String parameter to specify the name of the created recall set.

Example: See [MEMory:CATalog?](#)

Usage: Setting only

Manual operation: See "[New](#)" on page 486

MEMory:DElete[:NAME] <Name>

Closes the specified recall set.

Setting parameters:

<Name> String parameter to specify the name of the recall set to be closed.

Example: See [MEMory:CATalog?](#)

Usage: Setting only

MEMory:DElete:ALL

Deletes all loaded recall sets.

Example: MEM:DEL:ALL; :MEM:CAT?
 Delete all recall sets. The query MEM:CAT? returns an empty string. The local screen shows no recall set.

Usage: Event

MEMory:SElect <RecallSet>

Selects a recall set as the active recall set or returns the name of the active recall set.

Parameters:

<RecallSet> String parameter to specify the recall set.

Example:

```
*RST; :MEM:DEF 'SET_2'
```

Create a recall set named "SET_2" and make it the active recall set.

```
MEM:SEL 'Set1'
```

Activate the default recall set"Set1".

```
MMEM:STOR:STAT 1, 'C:\Users\Public\Documents\Rohde-Schwarz\Vna\RecallSets\Set1.znx'; :MEM:DEL 'Set1.znx'
```

Store the active recall set"Set1" to a file, renaming it Set1.znx.
Close the recall set.

8.3.11 MMEMory Commands

The `MMEMory...` commands provide mass storage capabilities for the analyzer.

Internal and external mass storage

The mass storage of the analyzer can be internal or external. The internal mass storage location is either the public folder or the instrument folder of the internal hard disk (`C:\Users\Public` or `C:\Users\Instrument`, see below). The external mass storage device can be a USB memory stick connected to one of the USB ports (mapped to any free drive letter) or a network connection.

File and directory names

The parameters for file names and directory names are strings. Some commands use a fixed "working" directory. For others, the file name parameter must contain the absolute path including the drive name and all subdirectories. If the specified path is not absolute, the file location is interpreted relative to the current directory (queried with `MMEMory:CDIRectory`). The file name itself can contain the period as a separator for extensions.

File and directory names can be chosen according to Windows® conventions. All letters and numbers are allowed, plus the special characters `"_"`, `"^"`, `"$"`, `"~"`, `"!"`, `"#"`, `"%"`, `"&"`, `"-"`, `"{"`, `"}"`, `"("`, `)"`, `"@"` and `"\"`. Reserved file names are CON, AUX, COM1, ..., COM4, LPT1, ..., LPT3, NUL and PRN. The use of wildcards `?` and `*` is not allowed.

Public folders in Windows® and default file locations

To achieve maximum system security, most of the folders on the internal hard disk are read-only folders. Only the following folders can be changed:

- `C:\Users\Public`

- C:\Users\Instrument

The public and instrument folders can be used to store user data. To simplify this task, the public folder contains predefined subfolders; e.g. the subfolder

C:\Users\Public\Documents\Rohde-Schwarz\Vna\Calibration\Kits is intended for calibration kit data. The subfolder structure is similar to R&S ZVA/B instruments, however, the R&S ZVA/B default path C:\Rohde&Schwarz\Nwa is replaced by C:\Users\Public\Documents\Rohde-Schwarz\Vna..

MMEMory:AKAL:FACTory:CONVersion.....	843
MMEMory:AKAL:USER:CONVersion.....	843
MMEMory:CATalog?.....	844
MMEMory:CATalog:ALL?.....	845
MMEMory:CDIRectory.....	845
MMEMory:CKIT:INFO?.....	845
MMEMory:COpy.....	846
MMEMory:DATA.....	846
MMEMory:DELeTe.....	847
MMEMory:DELeTe:CORRection.....	847
MMEMory:FAVorite<FavId>.....	847
MMEMory:LOAD:CABLe.....	848
MMEMory:LOAD:CKIT.....	848
MMEMory:LOAD:CKIT:SDATa.....	849
MMEMory:LOAD:CKIT:SDATa:WLABel.....	850
MMEMory:LOAD:CKIT:UDIRectory.....	851
MMEMory:LOAD:CMAP.....	852
MMEMory:LOAD:CORRection.....	852
MMEMory:LOAD:CORRection:MERGe.....	853
MMEMory:LOAD:CORRection:RESolve.....	854
MMEMory:LOAD:CORRection:TCOefficient<Ch>.....	855
MMEMory:LOAD:LIMit.....	855
MMEMory:LOAD:RIPPLe.....	857
MMEMory:LOAD:SEGMENT.....	858
MMEMory:LOAD:STATe.....	859
MMEMory:LOAD:TRACe.....	859
MMEMory:LOAD:TRACe:AUTO.....	860
MMEMory:LOAD:VNETworks<Ch>:BALanced:DEEMbedding<LogPt>.....	860
MMEMory:LOAD:VNETworks<Ch>:BALanced:EMBedding<LogPt>.....	860
MMEMory:LOAD:VNETworks<Ch>:DIFFerential:EMBedding<LogPt>.....	862
MMEMory:LOAD:VNETworks<Ch>:GLOop:DEEMbedding.....	862
MMEMory:LOAD:VNETworks<Ch>:GLOop:EMBedding<group>.....	862
MMEMory:LOAD:VNETworks<Ch>:PPAir:DEEMbedding<ListId>.....	863
MMEMory:LOAD:VNETworks<Ch>:PPAir:EMBedding<ListId>.....	863
MMEMory:LOAD:VNETworks<Ch>:SENDED:DEEMbedding<PhyPt>.....	865
MMEMory:LOAD:VNETworks<Ch>:SENDED:EMBedding<PhyPt>.....	865
MMEMory:MDIRectory.....	865
MMEMory:MOVE.....	866
MMEMory:MSIS.....	866
MMEMory:NAME.....	867
MMEMory:RDIRectory.....	867
MMEMory:STORe:CABLe.....	867

MMEMory:STORe:CKIT.....	868
MMEMory:STORe:CKIT:WLABel.....	868
MMEMory:STORe:CMAP.....	869
MMEMory:STORe:CORRection.....	869
MMEMory:STORe:CORRection:TCOEfficient<Ch>.....	870
MMEMory:STORe:LIMit.....	870
MMEMory:STORe:MARKer.....	870
MMEMory:STORe:RIPPlE.....	871
MMEMory:STORe:SEGMENT.....	871
MMEMory:STORe:STATe.....	872
MMEMory:STORe:TRACe.....	872
MMEMory:STORe:TRACe:CHANnel.....	873
MMEMory:STORe:TRACe:OPTion:BALanced.....	875
MMEMory:STORe:TRACe:OPTion:SYMMetric.....	875
MMEMory:STORe:TRACe:OPTion:COMMeNt.....	875
MMEMory:STORe:TRACe:OPTion:DECimals:STIMulus.....	875
MMEMory:STORe:TRACe:OPTion:DECimals:DATA.....	875
MMEMory:STORe:TRACe:OPTion:FORMat.....	876
MMEMory:STORe:TRACe:OPTion:PLUS.....	876
MMEMory:STORe:TRACe:OPTion:SSEParator.....	876
MMEMory:STORe:TRACe:OPTion:TABS.....	876
MMEMory:STORe:TRACe:OPTion:TRIM.....	877
MMEMory:STORe:TRACe:PORTs.....	877

MMEMory:AKAL:FACTory:CONVersion <Directory>

Converts the factory calibration data of the standards in the active calibration unit (`SYSTem:COMMunicate:RDEvice:AKAL:ADDRESS`) to Touchstone format and copies it to the specified directory.

Setting parameters:

<Directory> String parameter to specify the directory.

Example:

```
MMEM:AKAL:FACTory:CONVersion 'C:\Users\Public\
Documents\Rohde-Schwarz\Vna\AKAL\Touchstone'
```

Convert and copy the factory calibration data of the active calibration unit to the specified (writable) directory.

Usage: Setting only

Manual operation: See "[Apply/Cancel](#)" on page 384

MMEMory:AKAL:USER:CONVersion <Directory>[, <CalKitFile>]

Converts an arbitrary (e.g. user-defined) set of calibration data of the standards in the active calibration unit (`SYSTem:COMMunicate:RDEvice:AKAL:ADDRESS`) to Touchstone format and copies it to the specified directory.

Setting parameters:

<Directory> String parameter to specify the directory.

<CalKitFile>

Name and (possibly) directory of the cal kit file to be used for the automatic calibration (optional string parameter):

– If the parameter is omitted, the analyzer uses the last characterized cal kit file.

– If an empty string (' ') is specified, the factory cal kit file stored in the active calibration unit (`SYSTEM:COMMunicate:RDEvice:AKAL:ADDRESS`) is used. By default this file is also used in manual control.

– A cal kit file name `*.calkit` without path denotes a specific cal kit file stored in the active calibration unit.

– A cal kit file name `*.calkit` with path denotes a specific cal kit file stored in an arbitrary directory.

Example:

```
MMEM:AKAL:USER:CONV 'C:\Users\Public\
Documents\Rohde-Schwarz\Vna\AKAL\Touchstone'
Convert and copy the calibration data of the standards of the last
characterized cal kit to the specified (writable) directory.
MMEM:AKAL:USER:CONV 'C:\Users\Public\
Documents\Rohde-Schwarz\Vna\AKAL\Touchstone',
'user.calkit'
Convert and copy the calibration data of the standards of the
user-defined cal kit 'user.calkit' to the specified directory.
```

Usage:

Setting only

Manual operation: See "[Apply/Cancel](#)" on page 384

MMEMory:CATalog? [<Directory>]

Returns the contents of the current or of a specified directory. The directory information is returned in the following format:

```
<Used Size>, <FreeDiskSpace>{,<FileEntry>}{,<DirectoryEntry>}
```

The information elements indicate the following:

- <Used Size> – disk space in bytes used by the listed files, excluding subdirectories
- <FreeDiskSpace> – available free disk space in bytes
- <FileEntry> – file name, (blank), file size in bytes
- <DirectoryEntry> – directory name, <Dir>, (blank)

Tip: Use `MMEMory:CATalog:ALL?` to query the contents of the current directory and all subdirectories.

Query parameters:

<Directory>

String parameter to specify the directory. If the directory is omitted, the command queries the contents of the current directory, to be queried with `MMEMory:CDIRectory?`.

Example:

```
MMEM:CAT?
Possible response: 0, 771604480, calibration,
<DIR>, , colorschemes, <DIR>, ,....
```

Usage: Query only

MMEMory:CATalog:ALL? [<Directory>]

Returns the contents of the current or of a specified directory and all subdirectories. The information is returned in the following format:

Directory of <Directory>, <Used Size>, <FreeDiskSpace>{,<FileEntry>}{,<DirectoryEntry>}{,<Subdirectory>, <Used Size>, <FreeDiskSpace>{,<FileEntry>}{,<DirectoryEntry>}}

See also [MMEMory:CATalog?](#).

Tip: Use [MMEMory:CATalog?](#) to query the contents of the current directory.

Query parameters:

<Directory> String parameter to specify the directory path. If the directory is omitted, the command queries the contents of the current directory, to be queried with [MMEMory:CDIRectory?](#)

Example:

MMEM:CAT:ALL?

Possible response:

```
Directory of C:\Users\Public\Documents\
Rohde-Schwarz\Vna\,0, 2283155456,
calibration, <DIR>, , colorschemes, <DIR>,
, hardcopy, <DIR>, , limitlines, <DIR>, , ...
```

Usage: Query only

MMEMory:CDIRectory <Directory>

Changes the *current directory* for MMEMory commands.

Relative paths are interpreted relative to this directory.

Parameters:

<Directory> String parameter to specify the directory. If DEFault is used, the analyzer selects the default directory
C:\Users\Public\Documents\Rohde-Schwarz\Vna.

Example:

MMEMory:CDIRectory 'C:\temp'

sets the current directory to C:\temp.

MMEMory:CATalog? 'somedir'

lists the content of C:\temp\somedir.

See also [MMEMory:MSIS](#) and the condensed programming example in section [Path Independent RC Programs](#).

MMEMory:CKIT:INFO? <CalKitFile>[, <Detail>]

Queries connector type, name, label and gender of a cal kit defined in the specified cal kit file

Query parameters:

<CalKitFile>	Path to the cal kit file, either absolute or relative to the current directory (see MMEMory:CDIRectory)
<Detail>	CONNector LABEL NAME GENDER If specified, the command only returns the corresponding property

Return values:

<ConnectorType>	
<CalKitName>	
<KitLabel>	
<Gender>	1 : has a gender 0 : doesn't have a gender

Usage: Query only

MMEMory:COPY <SourceFile>, <NewFile>

Copies an existing file to a new file.

Setting parameters:

<SourceFile>	
<NewFile>	String parameters to specify the name of the file to be copied and the name of the new file. *RST: n/a

Example:

```
MMEM:COPY 'C:\Users\Public\Documents\
Rohde-Schwarz\Vna\RecallSets\SET1.znx', 'D:'
Copy file Set1.znx in directory
C:\Users\Public\Documents\Rohde-Schwarz\Vna\
RecallSets to the external storage medium, mapped to drive
D:.
```

Usage: Setting only

MMEMory:DATA <Filename>[, <DataBlock>]

Loads a <DataBlock> into the file <FileName>.

Parameters:

<Filename>	String parameter to specify the name of the file.
<DataBlock>	<block_data> Data in IEEE488.2 block data format. The delimiter EOI must be selected to achieve correct data transfer.

Example:

```
MMEM:DATA? 'C:\Users\Public\TEST01.HCP'
Query the block data contained in file TEST01.HCP.
```

MMEMory:DELeTe <File>[, <Force>]

Removes a file from the specified directory.

Setting parameters:

<File>	Mandatory string parameter containing the path and file name of the removed file. If the path is omitted, the current directory is used (see MMEMory:CDIRectory).
<Force>	FORCe Optional parameter, allows you to delete read-only files, too.

Example:

```
MMEM:DEL 'C:\Users\Public\TEST01.HCP'
```

Remove file TEST01.HCP from the directory C:\Users\Public. The file must not be read-only; otherwise the additional parameter FORCe is required.

Usage:

Setting only

MMEMory:DELeTe:CORRection <CalGroupName>

Deletes a system error correction data set stored in the cal pool (cal group file).

Setting parameters:

<CalGroupName>	String parameter to specify the name of the cal group file to be deleted. Cal group files must have the extension *.cal. The directory path must not be specified; the analyzer always uses the default cal pool directory C:\Users\Public\Documents\Rohde-Schwarz\Vna\Calibration\Data.
----------------	---

Example:

See [MMEMory:LOAD:CORRection](#)

Usage:

Setting only

Manual operation: See "[Pool / Delete from Pool](#)" on page 425

MMEMory:FAVorite<FavId> <RecallSetFile>

Manages the list of favorite recall sets

Suffix:

<FavId>	Position in the favorites list
---------	--------------------------------

Setting parameters:

<RecallSetFile>	File path, either absolute or relative to the current directory (see MMEMory:CDIRectory). The empty string represents an empty position in the favorites list. Note that when a non-empty favorite is set, the target recall set must exist.
-----------------	--

Example:

```

:MMEMory:CDIRectory DEFault
:MMEM:FAV1 'RecallSets\My_RecallSet1.znx'
Sets My_RecallSet1.znx at position 1 of the favorites list.
MMEM:FAV1?
Returns 'C:\Users\Public\Documents\Rohde-Schwarz\
Vna\RecallSets\My_RecallSet1.znx'
MMEM:FAV1 'RecallSets\My_RecallSet2.znx'
Sets My_RecallSet2.znx as favorite 1, overwriting the previ-
ous favorite 1
MMEM:FAV1 ''
Clears position 1 of the favorites list
MMEM:FAV1?
Returns ''

```

Manual operation: See ["Import"](#) on page 489

MMEMory:LOAD:CABLe <InputDir>

Loads Distance to Fault (DtF) cable type files (*.rsc) from the specified input directory.

Cable types are loaded "by name", overwriting user-defined cable types of the same name. Predefined cable types of the same name will not be overwritten.

Setting parameters:

<InputDir> Input Directory

Example:

```

MMEMory:STORe:CABLe 'C:\dtf-cables'
Saves all predefined and user-defined Distance to Fault (DtF)
cable types to the directory C:\dtf-cables.
Edit *.rsc files for user defined cable types, copy *.rsc files,
rename and edit them. Afterwards execute
MMEMory:LOAD:CABLe 'C:\dtf-cables'
to update existing and create new user-defined cable types.

```

Usage: Setting only

Options: R&S ZND-K3

Manual operation: See ["Add / Delete"](#) on page 501

MMEMory:LOAD:CKIT <CalKitFile>

Loads cal kit data from the specified cal kit file.

Setting parameters:

<CalKitFile> String parameter to specify name and directory of the loaded cal kit file. If no path is specified the analyzer searches the current directory, to be queried with [MMEMory:CDIRectory](#)

Example:

```
MMEM:LOAD:CKIT 'C:\Users\Public\Documents
\Rohde-Schwarz\Vna\Calibration\Kits\New_kit.calkit'
Load the previously created cal kit file New_kit.calkit from
the default cal kit directory.
... :MMEM:STOR:CKIT 'New_kit', 'C:
\Users\Public\Documents
\Rohde-Schwarz\Vna\Calibration\Kits\New_kit.calkit'
Store the data for the user-defined cal kit Newkit and overwrite
the cal kit file New_kit.calkit.
```

Usage: Setting only

Manual operation: See "[Import Cal Kit...](#)" on page 389

MMEMory:LOAD:CKIT:SDATa <ConnectorType>, <CalKitName>, <StandardType>, <StandardLabel>, <TouchstoneFile>[, <FirstPort>[, <SecondPort>]]

Loads cal kit data for a calibration standard from a specified Touchstone file. A restriction on the port assignment may be defined in addition.

Use the newer command [MMEMory:LOAD:CKIT:SDATa:WLABEL](#) to be able to distinguish cal kits by label.

Setting parameters:

<ConnectorType>	String parameter containing the name of the connector type.
<CalKitName>	String parameter containing the name of a calibration kit available on the analyzer.
<StandardType>	MMTHrough MFTHrough FFTHrough MMLine MMLine1 MMLine2 MMLine3 MFLine MFLine1 MFLine2 MFLine3 FFLine FFLine1 FFLine2 FFLine3 MMATten MFATten FFATten MMSNetwork MFSNetwork FFSNetwork MOPen FOPen MSHort FSHort MOShort MOShort1 MOShort2 MOShort3 FOSHort FOSHort1 FOSHort2 FOSHort3 MREFlect FREFlect MMTCh FMTCh MSMATCH FSMATCH Standard types; for a description refer to table Standard types and their parameters .
<StandardLabel>	String parameter addressing a particular calibration standard by its label. An empty string means that no label is defined.
<TouchstoneFile>	String parameter to specify name and directory of the Touchstone file to be loaded. A *.s1p file must be used for one-port standards, a *.s2p file for two-port standards. If no path is specified the analyzer searches the current directory, to be queried with MMEMory:CDIRECTORY *RST: -
<FirstPort>	First port number (sufficient for one-port standards). If the port numbers are omitted, the cal kit data is valid for all ports.
<SecondPort>	Second port number, for two-port standards. If the port numbers are omitted, the cal kit data is valid for all ports.

Example: `MMEM:LOAD:CKIT:SDAT 'N 50 Ohm', 'Default Kit', MOPEN, 'Test data', 'test.s1p', 1`
 Load the file Test.s1p from the current directory in order to define the properties of an Open (m) standard in the cal kit named "Default Kit" for the N 50 Ω connector type. Assign the label "Test data" and specify that the standard data is valid for port no. 1 only.

Usage: Setting only

Manual operation: See ["Read .s1p File... / Read .s2p File..."](#) on page 407

Connector and cal kit naming conventions:

Connector and calibration kit names must be entered as string parameters. The strings contain the connector and cal kit names used in the `Calibration Kits` dialog; a Ω in the name must be replaced by 'Ohm', e.g.:

-'NewKit1' denotes the user-defined calibration kit "NewKit1".

-'N 50 Ohm Ideal Kit' denotes the "N 50 Ω Ideal Kit".

-'ZV-Z21 typical' denotes the cal kit "ZV-Z21 typical".

MMEMory:LOAD:CKIT:SDATa:WLABel <ConnectorType>, <CalKitName>, <KitLabel>, <StandardType>, <StandardLabel>, <TouchstoneFile>[, <FirstPort>[, <SecondPort>]]

Loads characterization data from the given Touchstone file; similar to existing command `MMEMory:LOAD:CKIT:SDATa` but supports cal kit addressing **by label**.

Setting parameters:

<ConnectorType> String parameter containing the name of the connector type.

<CalKitName> String parameter containing the name of a calibration kit available on the analyzer.

<KitLabel> String parameter containing the label of a calibration kit available on the analyzer. An empty string means that no label is defined.

<StandardType> MMTrough | MFTrough | FFTHrough | MMLine | MMLine1 | MMLine2 | MMLine3 | MFLine | MFLine1 | MFLine2 | MFLine3 | FFLine | FFLine1 | FFLine2 | FFLine3 | MMATten | MFATten | FFATten | MMSNetwork | MFSNetwork | FFSNetwork | MOPen | FOPen | MSHort | FSHort | MOShort | MOShort1 | MOShort2 | MOShort3 | FOSHort | FOSHort1 | FOSHort2 | FOSHort3 | MREFlect | FRElect | MMTCh | FMTCh | MSMatch | FSMatch
 Standard types; for a description refer to table [Standard types and their parameters](#).

<StandardLabel> String parameter addressing a particular calibration standard by its label. An empty string means that no label is defined.

<TouchstoneFile>	String parameter to specify the name and directory of the Touchstone file to be loaded. A *.s1p file must be used for one-port standards, a *.s2p file for two-port standards. If no path is specified the analyzer searches the current directory, to be queried with MMEMory:CDIRectory
<FirstPort>	First port number (sufficient for one-port standards). If the port numbers are omitted, the cal kit data is valid for all ports.
<SecondPort>	Second port number, for two-port standards. If the port numbers are omitted, the cal kit data is valid for all ports.
Example:	<pre>MMEM:LOAD:CKIT:SDAT:WLAB 'N 50 Ohm', 'Default Kit', '0815', MOPEN, 'Test data', 'test.s1p', 1</pre> <p>Load the file Test.s1p from the current directory in order to define the properties of an Open (m) standard in the cal kit "Default Kit" with label "0815" for the N 50 Ω connector type. Assign the label "Test data" and specify that the standard data is valid for port no. 1 only.</p>

Usage: Setting only

Connector and cal kit naming conventions:

Connector and calibration kit names must be entered as string parameters. The strings contain the connector and cal kit names used in the *Calibration Kits* dialog; a Ω in the name must be replaced by 'Ohm', e.g.:

- 'NewKit1' denotes the user-defined calibration kit "NewKit1".
- 'N 50 Ohm Ideal Kit' denotes the "N 50 Ω Ideal Kit".
- 'ZV-Z21 typical' denotes the cal kit "ZV-Z21 typical".

MMEMory:LOAD:CKIT:UDIRectory <Directory>

Specifies the "Search Path for Additional Cal Kits and Connector Types". All cal kit files in the specified directory will be (re-)loaded automatically as predefined kits (i.e. read-only kits which cannot be modified) every time the VNA application is started.

Parameters:

<Directory> String parameter to specify the directory path. The directory can be created separately ([MMEMory:MDIRectory](#)). An empty string means that no cal kit files will be loaded.

Example: MMEM:LOAD:CKIT:UDIR 'C:\Users\Public\Documents\Rohde-Schwarz\Vna\Calibration\Kits\Autoload'
Specify the directory for additionally available cal kits.
MMEM:MDIR 'C:\Users\Public\Documents\Rohde-Schwarz\Vna\Calibration\Kits\Autoload'
Create the specified "Autoload" directory.
MMEM:STOR:CKIT 'New Kit 1', 'C:\Users\Public\Documents\Rohde-Schwarz\Vna\Calibration\Kits\Autoload\New Kit 1.calkit'
Store the data for the existing, user-defined cal kit "New Kit 1" to the "Autoload" directory.

Manual operation: See ["Search Path for additional Cal Kits and Connector Types"](#) on page 522

MMEMory:LOAD:CMAP <ColorSchemeFile>

Loads a color scheme from a specified VNA color scheme file.

Setting parameters:

<ColorSchemeFile> String parameter to specify the name and directory of the color scheme file to be loaded. The default extension (manual control) for color scheme files is *.ColorScheme, although other extensions are allowed.

Example: MMEM:LOAD:CMAP 'C:\Users\Public\Documents\Rohde-Schwarz\Vna\ColorSchemes\Test.ColorScheme'
Load the previously created color scheme file Test.ColorScheme from the default color scheme directory.
DISP:CMAP13:RGB 1,0,0; :DISP:CMAP14:RGB 0,1,0
Color the first trace red, the second trace green.
MMEM:STOR:CMAP 'C:\Users\Public\Documents\Rohde-Schwarz\Vna\ColorSchemes\Test.ColorScheme'
Store the data for the user-defined cal kit "Newkit" and overwrite the cal kit file New_kit.calkit.

Usage: Setting only

Manual operation: See ["Recall... / Save..."](#) on page 514

MMEMory:LOAD:CORRection <Channel>[, <CalGroupFile>]

Applies a system error correction data set stored in the cal pool (cal group file) to channel <Channel>.

Parameters:

<Channel> Channel number of an existing channel. ALL applies the selected data set to all channels.

<CalGroupFile> String parameter to specify the name of the cal group file to be loaded. Cal group files must have the extension *.cal. The directory path must not be specified; the analyzer always uses the default cal pool directory C:\Users\Public\Documents\Rohde-Schwarz\Vna\Calibration\Data.

Example:

```
MMEM:STOR:CORR 1, 'Calgroup1.cal'
```

Copy the current correction data set of channel 1 to a cal group file Calgroup1.cal.

```
CONF:CHAN2:STAT ON; :MMEM:LOAD:CORR 2, 'Calgroup1.cal'
```

Apply the stored correction data (cal group file) to channel 2.

```
MMEM:LOAD:CORR? 2
```

Query the cal group file for channel 2. Response:

```
'Calgroup1.cal'
```

```
MMEM:LOAD:CORR:RES 2, 'Calgroup1.cal'
```

Resolve the pool link between channel 2 and the cal group file.

```
MMEM:LOAD:CORR? 2
```

Query the cal group file for channel 2. Response: ''

```
MMEM:DEL:CORR 'Calgroup1.cal'
```

Delete the created cal group file.

Manual operation: See ["Add / Add All... / Replace / Apply / Apply to All"](#) on page 424

MMEMory:LOAD:CORRection:MERGe <Channel>[, <CalGroupFile>[, <CalGroupFile>]...]

Merges (activates) several cal group files for channel no. <Channel> so that the query [SENSe<Ch>:]CORRection:COLLect:METHod:DEFine? returns a list of all merged calibration types (equivalent to the calibration pool list in the "Calibration Manager" dialog). The merged cal group files can be stored to a common file (see example).

Note that the calibrations to be merged must be based on the same frequency grid (identical frequency sweep points).

Setting parameters:

<Channel> Channel number of an existing channel

<CalGroupFile>

<CalGroupFile> String parameters with the names of the merged cal group files. Cal group files must have the extension *.cal. The file extensions must be specified as part of the string parameters. In contrast the directory path must not be specified; the analyzer always uses the default path
C:\Users\Public\Documents\Rohde-Schwarz\Vna\CALibration\DATA.

- Example:**
- ```
SENS1:CORR:COLL:METH:DEF 'Test', FRTRans, 1, 3
```
- Select a bidirectional transmission normalization between ports 1 and 3 as a calibration type for channel 1.
- ```
CORR:COLL:SAVE:SEL:DEF; :MMEM:STOR:CORR 1, 'P1-P3.cal'
```
- Create a default calibration data set for the selected calibration type and store the data to a cal group file.
- ```
SENS1:CORR:COLL:METH:DEF 'Test', FRTRans, 1, 4
```
- Select a bidirectional transmission normalization between ports 1 and 4 as a calibration type for channel 1.
- ```
CORR:COLL:SAVE:SEL:DEF; :MMEM:STOR:CORR 1, 'P1-P4.cal'
```
- Create a default calibration data set for the selected calibration type and store the data to a cal group file.
- ```
CORR:COLL:METH:DEF?
```
- Query the active calibrations for channel 1. The response is FRTR0104 (the last data set stored).
- ```
MMEM:LOAD:CORR:MERGE 1, 'P1-P3.cal', 'P1-P4.cal'; :CORR:COLL:METH:DEF?
```
- Merge the two calibration types and query the active calibrations again. The response is FRTR0103, FRTR0104.
- ```
MMEM:STOR:CORR 1, 'Merged.cal'
```
- Store both sets of calibration data to a common cal group file.
- Usage:** Setting only
- Manual operation:** See ["Add / Add All... / Replace / Apply / Apply to All"](#) on page 424

---

### MMEMory:LOAD:CORRection:RESolve <Channel>[, <CalGroupFile>]

Resolves the pool link between channel <Channel> and a correction data set (cal group file). After resolving the pool link, the analyzer keeps the previous system error correction as a channel calibration ("Channel Cal"). A new calibration will replace the channel calibration but not overwrite the old cal group file (and not affect other channels).

#### Setting parameters:

- <Channel> Channel number of an existing channel. ALL resolves the pool link for all channels.
- <CalGroupFile> Optional string parameter to specify the name of the cal group file. Cal group files must have the extension \*.cal. The directory must not be specified; the analyzer always uses the default path C:\Users\Public\Documents\Rohde-Schwarz\Vna\Calibration\Data. If there is no link between <Ch> and the specified file, the command has no effect. If no file is specified, the command resolves any link between <Ch> and an arbitrary cal group file.

- Example:** See [MMEMory:LOAD:CORRection](#)
- Usage:** Setting only
- Manual operation:** See "[Resolve Pool Link / Remove Pool Link](#)" on page 425

### **MMEMory:LOAD:CORRection:TCOefficient<Ch>** <TraceFile>[, <Trace>]

Loads power meter (two-port) transmission coefficients from the specified power meter correction file or trace file to channel <Ch>.

**Suffix:**

<Ch> Channel number

**Setting parameters:**

- <TraceFile> String parameter specifying the name and directory of the loaded trace file. The R&S ZND supports power meter correction list files (\*.pmcl, generated using [MMEMory:STORe:CORRection:TCOefficient<Ch>](#)), \*csv, and Touchstone (\*.s1p, \*.s2p, ...) files. If no path is specified the analyzer searches the current directory, to be queried with [MMEMory:CDIRectory](#). The file extensions \*.s<n>p, \*csv, and \*.pmcl for Touchstone, ASCII, and power meter correction list files are mandatory.
- \*RST: n/a
- <Trace> Optional string parameter: For multiport Touchstone files (\*.snp, n > 1), the parameter refers to a particular S-parameter trace ('S11', 'S12', ...). For ASCII (\*.csv) files, the parameter references a trace name in the file (case sensitive). If the parameter is omitted, the first trace in the specified file is imported. This parameter is not used for power meter correction list files (\*.pmcl).
- \*RST: n/a

**Example:** See [SOURce<Ch>:POWer<PhyPt>:CORRection:TCOefficient:CALibration](#)

**Usage:** Setting only

**Manual operation:** See "[Import File...](#)" on page 420

### **MMEMory:LOAD:LIMit** <TraceName>, <LimLineFile>[, <TouchstoneFile>[, <StimulusOffset>[, <ResponseOffset>[, <LimLineType>]]]]

Loads a limit line definition from a specified file and assigns it to a trace with a specified name. Limit lines are created using the [CALCulate<Ch>:LIMit...](#) commands.

**Note:** Limit lines can be loaded from Touchstone files (\*.s<n>p, where <n> denotes the number of ports). The optional parameters '<TouchstoneFile>', <StimulusOffset>, <ResponseOffset>, <LimLineType> are only relevant for Touchstone files. For \*.limit files, no optional parameters can be set.

**Setting parameters:**

|                  |                                                                                                                                                                                                                                                                                                                                                                            |
|------------------|----------------------------------------------------------------------------------------------------------------------------------------------------------------------------------------------------------------------------------------------------------------------------------------------------------------------------------------------------------------------------|
| <TraceName>      | Name of an existing trace in the active recall set (string parameter). The imported limit line is assigned to this trace, irrespective of the trace information in the limit line file.                                                                                                                                                                                    |
| <LimLineFile>    | String parameter to specify the name and directory of the limit line file to be loaded. The default extension (manual control) for limit line files is *.limit, although other extensions are allowed. If no path is specified the analyzer searches the current directory, to be queried with <code>MMEMoRY:CDIRECTORY?</code> . See also note on Touchstone files above. |
| <TouchstoneFile> | String parameter, selects an S-parameter from a Touchstone file. The parameter must be compatible with the file type (e.g. for one-port Touchstone files *.s1p, only the parameter name 'S11' is allowed).<br>*RST: 'S11' (if all optional parameters are omitted)                                                                                                         |
| <StimulusOffset> | Stimulus offset for limit lines loaded from a Touchstone file. A 1 GHz offset shifts the limit line by 1 GHz in (positive) horizontal direction.<br>Range: Depending on the sweep range of the analyzer.<br>*RST: 0<br>Default unit: NN                                                                                                                                    |
| <ResponseOffset> | Response offset for limit lines loaded from a Touchstone file. A 1 dB offset shifts the limit line by 1 dB in (positive) vertical direction.<br>Range: Depending on the measured quantity.<br>*RST: 0<br>Default unit: NN                                                                                                                                                  |
| <LimLineType>    | LMIN   LMAX   OFF<br>Limit line type :<br>LMAX - upper limit line<br>LMIN - lower limit line<br>OFF - limit line off<br>*RST: LMAX (if all optional parameters are omitted)                                                                                                                                                                                                |

- Example:** Assume that the current recall set contains two traces named Trc1 and Trc2, respectively, and that limit lines have been defined for Trc1.
- ```
MMEM:STOR:LIM 'TRC1', 'C:
\Users\Public\Documents
\Rohde-Schwarz\Vna\LIMitLines\Lim_Trc1.limit'
```
- Store the limit line definition of Trc1 to a limit line file.
- ```
MMEM:LOAD:LIM 'TRC2', 'C:
\Users\Public\Documents
\Rohde-Schwarz\Vna\LIMitLines\Lim_Trc1.limit'
```
- Load the previously created limit line file and assign the limit lines to Trc2.
- ```
MMEM:STOR:TRAC 'TRC1', 'C:
\Users\Public\Documents
\Rohde-Schwarz\Vna\LIMitLines\Trc1.slp'
```
- Store the current trace data of Trc1 to a limit line file in Touchstone format.
- ```
MMEM:LOAD:LIM 'TRC1', 'C:
\Users\Public\Documents
\Rohde-Schwarz\Vna\LIMitLines\Trc1.slp', 'S11',
0, 2, LMAX
```
- Load the previously created Touchstone limit line file and assign the limit lines to Trc1, applying a response offset of 2 dB.
- ```
CALC:LIMit:DISPlay ON
```
- Show the limit line in the diagram.
- Usage:** Setting only
- Manual operation:** See "[Recall... / Save...](#)" on page 310

MMEMory:LOAD:RIPple <TraceName>, <RippleLimFile>

Loads a ripple limit definition from a specified file and assigns it to a trace with a specified name. Ripple limits are created using the `CALCulate<Ch>:RIPple...` commands.

Setting parameters:

- <TraceName> Name of an existing trace in the active setup (string parameter). The imported ripple limit line is assigned to this trace, irrespective of the trace information in the ripple limit file.
- *RST: -
- <RippleLimFile> String parameter to specify the name and directory of the ripple limit file to be loaded. The default extension (manual control) for ripple limit files is *.ripple, although other extensions are allowed. If no path is specified the analyzer searches the current directory, to be queried with `MMEMory:CDIRectory`

- Example:** Assume that the current setup contains two traces named Trc1 and Trc2, respectively, and that ripple limits have been defined for Trc1.
- ```
MMEM:STOR:RIPP 'TRC1', 'C:
\Users\Public\Documents
\Rohde-Schwarz\Vna\LIMitLines\Lim_Trcl.limit'
```
- Store the ripple limit definition of Trc1 to a ripple limit file.
- ```
MMEM:LOAD:RIPP 'TRC2', 'C:
\Users\Public\Documents
Rohde-Schwarz\Vna\LIMitLines\Lim_Trcl.limit'
```
- Load the previously created ripple limit file and assign the limits to Trc2.
- ```
CALC:RIPP:DISPlay ON
```
- Show the ripple limit line for the active trace in the diagram.
- Usage:** Setting only
- Manual operation:** See "[Recall Ripple Test.../Save Ripple Test...](#)" on page 317

---

#### **MMEMory:LOAD:SEGMent** <Channel>, <SweepSegFile>

Replaces the related channel's current sweep segment definition by a sweep segment definition loaded from the specified ASCII file.

#### **Setting parameters:**

- <Channel> Channel number
- <SweepSegFile> String parameter to specify the name and directory of the sweep segment file to be loaded. The default extension (manual control) for sweep segment files is \*.SegList, although other extensions are allowed. If no path is specified the analyzer searches the current directory, to be queried with [MMEMory:CDIRectory](#)

- Example:** Assume that the current recall set contains two channels numbered 1 and 2, respectively, and that sweep segments have been defined for channel no. 1.
- ```
MMEM:STOR:SEGM 1, 'C:\Users\Public\Documents\
Rohde-Schwarz\Vna\SweepSegments\Seg_Ch1.SegList'
```
- Store the sweep segment definition of channel 1 to a sweep segment file.
- ```
MMEM:LOAD:SEGM 2, 'C:\Users\Public\Documents\
Rohde-Schwarz\Vna\SweepSegments\Seg_Ch1.SegList'
```
- Load the previously created sweep segment file and use the sweep segments for channel 2.
- Usage:** Setting only
- Manual operation:** See "[Import.../Export...](#)" on page 363

**MMEMory:LOAD:STATe** <Compatibility>, <RecallSetFile>

Loads configuration data from a specified recall set file (\*.znx|\*.znxml) and sets the analyzer to the corresponding instrument state.

**Setting parameters:**

|                 |                                                                                                                                                                                                          |
|-----------------|----------------------------------------------------------------------------------------------------------------------------------------------------------------------------------------------------------|
| <Compatibility> | 1 (this value is used for compatibility with the SCPI standard but is ignored).                                                                                                                          |
| <RecallSetFile> | String parameter to specify the absolute or relative path of the recall set file to be loaded. Relative paths are evaluated relative to the current directory (see <a href="#">MMEMory:CDIRectory</a> ). |

**Example:**

```
MMEM:STOR:STAT 1, 'C:\Users\Public\Documents\
Rohde-Schwarz\Vna\RecallSets\Set_0413.znx'
Store the current setup configuration in the file Set_0413.znx
in the default directory for recall set files.
MMEM:LOAD:STAT 1, 'C:\Users\Public\Documents\
Rohde-Schwarz\Vna\RecallSets\Set_0413.znx'
Load the settings stored in Set_0413.znx.
```

**Usage:** Setting only

**Manual operation:** See "Open Recall..." on page 486

**MMEMory:LOAD:TRACe** <DestinationTraceName>, <TraceFile>[, <SParamOrTraceName>]

Loads trace data from a specified trace file and assigns it to a trace with a specified name. Traces are created using the [CALCulate<Ch>:PARAMeter:SDEFine](#) command.

**Setting parameters:**

|                        |                                                                                                                                                                                                                                                                                                                                                                            |
|------------------------|----------------------------------------------------------------------------------------------------------------------------------------------------------------------------------------------------------------------------------------------------------------------------------------------------------------------------------------------------------------------------|
| <DestinationTraceName> | Name of an existing data trace in the active recall set (string parameter). The trace data is loaded into a memory trace associated with the specified data trace. If one or more memory traces are already associated with the specified data trace, the last generated memory trace is overwritten.                                                                      |
| <TraceFile>            | String parameter to specify the name and directory of the trace file to be loaded. Several file formats for trace files are supported. The file extensions *.s<n>p, *.csv, and *.dat for Touchstone, ASCII, and Matlab files are mandatory. If no path is specified the analyzer searches the current directory, to be queried with <a href="#">MMEMory:CDIRectory</a>     |
| <SParamOrTraceName>    | Optional string parameter: For imported Touchstone files for more than one port (*.s2p, *.s3p, *.s4p), the parameter denotes the imported S-parameter ('S11', 'S12', ...). For ASCII (*.csv) and Matlab (*.dat) files, the parameter references a trace name in the file (case sensitive). If the parameter is omitted, the first trace in the specified file is imported. |

**Example:** Assume that the current recall set contains a trace named Trc1.  
 MMEM:STOR:TRAC 'TRC1', 'C:\Users\Public  
 \Documents\Rohde-Schwarz\Vna\Traces\Trc1.s1p'  
 Store the current trace data of Trc1 to a trace file.  
 MMEM:LOAD:TRAC 'TRC1', 'C:\Users\Public  
 \Documents\Rohde-Schwarz\Vna\Traces\Trc1.s1p'  
 Load the previously created trace file and create a memory trace  
 assigned to Trc1.  
 CALC:PAR:DEF:SGR 1,2  
 Create four traces to measure the two-port S-parameters  $S_{11}$ ,  
 $S_{12}$ ,  $S_{21}$ ,  $S_{22}$ . The traces are not displayed.  
 MMEM:STOR:TRAC 'TRC1', 'C:\Users\Public  
 \Documents\Rohde-Schwarz\Vna\Traces\Trc1.s2p'  
 Store the four S-parameter traces to a two-port Touchstone file.  
 MMEM:LOAD:TRAC 'TRC1', 'C:\Users\Public  
 \Documents\Rohde-Schwarz\Vna\Traces\Trc1.s2p'  
 Load the previously created Touchstone file and overwrite the  
 previously generated memory trace assigned to Trc1 with the  
 $S_{11}$  trace.

**Usage:** Setting only

**Manual operation:** See ["Import Data to New Mem"](#) on page 298

#### MMEMory:LOAD:TRACe:AUTO <TraceFile>

Loads the specified trace file and automatically distributes the imported S-parameter traces  $S_{ij}$  to all diagrams in the active channel that are currently displaying  $S_{ij}$ .

#### Setting parameters:

<TraceFile> String parameter to specify the name and directory of the trace file to be loaded. Several file formats for trace files are supported. The file extensions \*.s<n>p, \*.csv, and \*.dat for Touchstone, ASCII, and Matlab files are mandatory. If no path is specified the analyzer searches the current directory, to be queried with [MMEMory:CDIRectory](#)

**Usage:** Setting only

**Manual operation:** See ["Auto Distribute"](#) on page 302

#### MMEMory:LOAD:VNETworks<Ch>:BALanced:DEEMbedding<LogPt>

<TouchstoneFile>[, <Port>[, <Interchange>]]

#### MMEMory:LOAD:VNETworks<Ch>:BALanced:EMBedding<LogPt>

<TouchstoneFile>[, <Port>[, <Interchange>]]

Loads the S-parameter data that (partly) specify the de-/embedding network of balanced port <LogPt> from local Touchstone files.



Use `CALCulate<Ch>:TRANSform:VNETworks:BALanced:DEEMbedding<LogPt>:TNDefinition` or `CALCulate<Ch>:TRANSform:VNETworks:BALanced:EMBedding<LogPt>:TNDefinition` to select the desired **circuit model** **before** loading the data files.

- The `FIMPort` model requires a single `*.s4p` file and hence a single set command.
- The circuit models `STSL` | `STSC` | `SLST` | `SCST` require 2 `*.s2p` files, that have to be assigned to the appropriate port using two set commands.

**Suffix:**

|         |                     |
|---------|---------------------|
| <Ch>    | Channel number      |
| <LogPt> | Logical port number |

**Parameters:**

|                  |                                                                                                                                                                                                                                                                                                                                                                                                                                                                                                                                                                                                                                                                                                                                                                                                                                                                                |
|------------------|--------------------------------------------------------------------------------------------------------------------------------------------------------------------------------------------------------------------------------------------------------------------------------------------------------------------------------------------------------------------------------------------------------------------------------------------------------------------------------------------------------------------------------------------------------------------------------------------------------------------------------------------------------------------------------------------------------------------------------------------------------------------------------------------------------------------------------------------------------------------------------|
| <TouchstoneFile> | String parameter to specify the name and directory of the loaded Touchstone file.<br>If no path is specified the analyzer searches the current directory, which can be set and queried using <code>MMEMemory:CDIRectory</code>                                                                                                                                                                                                                                                                                                                                                                                                                                                                                                                                                                                                                                                 |
| <Port>           | <code>PMAin</code>   <code>PSECondy</code><br>Assigns a 2-port ( <code>*.s2p</code> ) file to the appropriate port. <code>PMAin</code> corresponds to D1, <code>PSECondy</code> to D2 in the <b>circuit model pictograms</b> .<br>For an <code>s4p</code> file, this parameter is ignored. However, it must be specified unless the <Interchange> parameter is also omitted.                                                                                                                                                                                                                                                                                                                                                                                                                                                                                                   |
| <Interchange>    | <code>FPORts</code>   <code>IPORts</code>   <code>SGATes</code>   <code>SINCreasing</code><br>Defines how to interpret the (implicit) port numbering of the Touchstone file in the context of the de-/embedding network.<br><b>FPORts (or omitted)</b><br>Standard interpretation: odd port numbers towards VNA, even port numbers towards DUT<br><b>IPORts</b><br>For <code>s2p</code> files <code>IPORts</code> means "inverted port sequence": network port 2 towards VNA, network port 1 towards DUT<br>For <code>s4p</code> files <code>IPORts</code> means "increasing port sequence": low port numbers towards VNA, high port numbers towards DUT<br><b>SGATes</b><br>Swapped gates: even port numbers towards VNA, odd port numbers towards DUT<br><b>SINCreasing</b><br>Swapped increasing port sequence: high port numbers towards VNA, low port numbers towards DUT |

**Example:**           \*RST; SOUR:LPOR1 1,2; LPOR2 3,4  
                   Define a balanced port configuration.  
                   CALC:TRAN:VNET:BAL:DEEM:TND STSL  
                   Select the "Serial .s2p data, shunt L" circuit model.  
                   MMEM:LOAD:VNET:BAL:DEEM2 'C:\Users\Public  
                   \Documents\Rohde-Schwarz\Vna\VNET\Test.s2p',  
                   PMA  
                   Load a Touchstone file and assign it to logical port no. 2.

**Manual operation:** See "[File Name <i>/Swap Gates](#)" on page 440

**MMEMory:LOAD:VNETworks<Ch>:DIFFerential:EMBedding<LogPt>**  
                   <TouchstoneFile>[, <Interchange>]

Loads data of a [Differential Match Embedding](#) network from the specified Touchstone  
 \* .s2p file.

Use [CALCulate<Ch>:TRANSform:VNETworks:BALanced:EMBedding<LogPt>](#):  
[PARAmeters:DATA<Port>](#) to load circuit data from the remote client instead.

The query returns the name of the loaded file.

**Suffix:**

<Ch>                   Channel number  
 <LogPt>               Logical port number of a balanced port

**Parameters:**

<TouchstoneFile>   String parameter to specify the name and directory of the loaded  
 \* .s2p file.  
 If no path is specified the analyzer searches the current direc-  
 tory, which can be set and queried using [MMEMory:](#)  
[CDIRectory](#)

<Interchange>       FPORts | IPORts | SGATes

**FPORts (or omitted)**  
 Standard port sequence (network port 1 towards VNA, network  
 port 2 towards DUT)

**IPORts | SGATes**  
 Inverted port sequence (network port 2 towards VNA, network  
 port 1 towards DUT)

**Example:**           MMEM:LOAD:VNET1:DIFF:EMBM1 'C:\Users\Public\  
                   Documents\Rohde-Schwarz\Vna\Embedding\Test.s2p'  
                   Load a Touchstone file.

**Manual operation:** See "[File Name 1](#)" on page 443

**MMEMory:LOAD:VNETworks<Ch>:GLOop:DEEMbedding <TouchstoneFile>**  
**MMEMory:LOAD:VNETworks<Ch>:GLOop:EMBedding<group> <TouchstoneFile>**

Loads data from a specified one-port (\* .s1p) Touchstone file defining a ground loop  
 circuit model for de-/embedding.

**Suffix:**

|         |                                                                                                                                                                                                                                                                                          |
|---------|------------------------------------------------------------------------------------------------------------------------------------------------------------------------------------------------------------------------------------------------------------------------------------------|
| <Ch>    | Channel number                                                                                                                                                                                                                                                                           |
| <group> | Port group (DUT) number.<br>If multiple port groups are configured (see <a href="#">SOURCE&lt;Ch&gt;:GROUp&lt;Grp&gt;:PPORts</a> ) and <a href="#">CALCulate&lt;Ch&gt;:TRANsform:VNETworks:GLOOp:GROUp</a> is ON, then each port group can have its own ground loop de-/embedding model. |

**Parameters:**

|                  |                                                                                                                                                                                                                                 |
|------------------|---------------------------------------------------------------------------------------------------------------------------------------------------------------------------------------------------------------------------------|
| <TouchstoneFile> | String parameter to specify the name and directory of the loaded Touchstone file.<br>If no path is specified the analyzer searches the current directory, which can be set and queried using <a href="#">MMEMory:CDIRectory</a> |
|------------------|---------------------------------------------------------------------------------------------------------------------------------------------------------------------------------------------------------------------------------|

**Example:**

```
CALC:TRAN:VNET:SEND:GLO:TND FIMP
Select the 1-Port Data (s1p) circuit model.
MMEM:LOAD:VNET:GLO:EMB 'C:\Users\Public\
Documents\Rohde-Schwarz\Vna\Embedding\Test.s1p'
Load a Touchstone file.
```

**Manual operation:** See "[File Name 1](#)" on page 441

**MMEMory:LOAD:VNETworks<Ch>:PPAir:DEEMbedding<ListId>**

<TouchstoneFile>[, <Port>[, <Interchange>]]

**MMEMory:LOAD:VNETworks<Ch>:PPAir:EMBedding<ListId>** <TouchstoneFile>[, <Port>[, <Interchange>]]

Loads the S-parameter data that (partly) specify the deembedding network of port group <ListId> from local Touchstone files.

Use [CALCulate<Ch>:TRANsform:VNETworks:PPAir:DEEMbedding<ListId>:TNDefinition](#) or [CALCulate<Ch>:TRANsform:VNETworks:PPAir:EMBedding<ListId>:TNDefinition](#) to select the desired **circuit model** before loading the data files.

- For any n-port set, the `FIMPort` model requires a single `*.s<2n>p` file and hence a single set command.
- For 2-port sets (port pairs), the circuit models `STSL` | `STSC` | `SLST` | `SCST` require 2 `*.s2p` files, that have to be assigned to the appropriate port using two set commands.

**Suffix:**

|          |                                                                                       |
|----------|---------------------------------------------------------------------------------------|
| <Ch>     | Channel number                                                                        |
| <ListId> | Index of the port set within the channel's overall list of port sets for deembedding. |

**Parameters:**

|                          |                                                                                                                                                                                                                                                                                                                                                                                                                                                                                                                                                                                                                                                                                                                                                                                                      |
|--------------------------|------------------------------------------------------------------------------------------------------------------------------------------------------------------------------------------------------------------------------------------------------------------------------------------------------------------------------------------------------------------------------------------------------------------------------------------------------------------------------------------------------------------------------------------------------------------------------------------------------------------------------------------------------------------------------------------------------------------------------------------------------------------------------------------------------|
| <TouchstoneFile>         | <p>String parameter specifying the name and directory of the loaded Touchstone file.</p> <p>If no path is specified, the analyzer searches the current directory, which can be set and queried using <a href="#">MMEMemory:CDIRectory</a></p>                                                                                                                                                                                                                                                                                                                                                                                                                                                                                                                                                        |
| <Port>                   | <p>PMAin   PSECondary</p> <p>For port pairs, &lt;Port&gt; assigns a 2-port (* .s2p) file to the appropriate port. PMAin corresponds to D1, PSECondary to D2 in the <a href="#">circuit model pictograms</a> for balanced ports</p> <p>For an s&lt;2m&gt;p file with m&gt;1, this parameter is ignored. However, it must be specified unless the &lt;Interchange&gt; parameter is also omitted.</p>                                                                                                                                                                                                                                                                                                                                                                                                   |
| <Interchange>            | <p>FPORts   IPORts   SGATes   SINCreasing</p> <p>Defines how to interpret the (implicit) port numbering of the Touchstone file in the context of the deembedding network.</p> <p><b>FPORts (or omitted)</b><br/>Standard interpretation: odd port numbers towards VNA, even port numbers towards DUT</p> <p><b>IPORts</b><br/>For s2p files IPORts means "inverted port sequence": network port 2 towards VNA, network port 1 towards DUT<br/>For s4p files IPORts means "increasing port sequence": low port numbers towards VNA, high port numbers towards DUT</p> <p><b>SGATes</b><br/>Swapped gates: even port numbers towards VNA, odd port numbers towards DUT</p> <p><b>SINCreasing</b><br/>Swapped increasing port sequence: high port numbers towards VNA, low port numbers towards DUT</p> |
| <b>Example:</b>          | <pre>*RST; :CALC:TRAN:VNET:PPA:DEEM:DEF 1,2,3,4 Define a port pair configuration with port pairs (1,2) and (3,4). CALC:TRAN:VNET:PPA:DEEM2:TND STSL Select the <i>Serial Touchstone .s2p data, shunt L</i> circuit mode for the second port pair. MME:LOAD:VNET:PPA:DEEM2 'C: \Rohde-Schwarz\Vna\Traces\Test.s2p', PMA Load a Touchstone file and assign it to the second port pair.</pre>                                                                                                                                                                                                                                                                                                                                                                                                           |
| <b>Manual operation:</b> | See " <a href="#">File Name &lt;i&gt;/Inc. Seq. &lt;i&gt;</a> " on page 439                                                                                                                                                                                                                                                                                                                                                                                                                                                                                                                                                                                                                                                                                                                          |

---

**MMEMory:LOAD:VNETworks<Ch>:SENDEd:DEEMbedding<PhyPt>**  
 <TouchstoneFile>[, <Interchange>]

**MMEMory:LOAD:VNETworks<Ch>:SENDEd:EMBedding<PhyPt>**  
 <TouchstoneFile>[, <Interchange>]

Loads data from a specified two-port (\* .s2p) Touchstone file defining a single ended circuit model for de-/embedding.

Use

- `CALCulate<Ch>:TRANSform:VNETworks:SENDEd:DEEMbedding<PhyPt>:TNDefinition` or `CALCulate<Ch>:TRANSform:VNETworks:SENDEd:EMBedding<PhyPt>:TNDefinition` to select the adequate circuit model **before** executing this command.
- `CALCulate<Ch>:TRANSform:VNETworks:SENDEd:EMBedding<PhyPt>:PARAMeters:DATA` to load circuit data from the remote client.

**Suffix:**

<Ch> Channel number  
 <PhyPt> Physical port number

**Parameters:**

<TouchstoneFile> String parameter to specify the name and directory of the loaded Touchstone file.  
 If no path is specified the analyzer searches the current directory, which can be set and queried using `MMEMory:CDIRectory`

<Interchange> FPORts | IPORts | SGATes  
**FPORts (or omitted)**  
 Standard port sequence (network port 1 towards VNA, network port 2 towards DUT)  
**IPORts | SGATes**  
 Inverted port sequence (network port 2 towards VNA, network port 1 towards DUT)

**Example:**

```
CALC:TRAN:VNET:SEND:EMB:TND FIMP
Select the "Serial .s2p" data circuit model.
MMEM:LOAD:VNET:SEND:EMB2 'C:\Users\Public
\Documents\Rohde-Schwarz\Vna\VNET\Test.s2p'
Load a Touchstone file and assign it to the physical port no. 2.
```

**Manual operation:** See "[File Name 1 / Swap Gates](#)" on page 437

---

**MMEMory:MDIRectory <NewDirectory>**

Creates a new subdirectory for mass memory storage in an existing directory.

**Setting parameters:**

<NewDirectory> String parameter to specify the new directory. Either the full path or a subdirectory for the current directory (see `MMEMory:CDIRectory`).

**Example:** MMEM:MDIR 'C:\Users\Public\New\_Directory'  
 Create the specified directory. The parent directory  
 C:\Users\Public must have been created before.  
 MMEM:MDIR 'C:  
 \Users\Public\New\_Directory\New\_Subdirectory'  
 Create an additional subdirectory.  
 MMEM:CDIR 'C:\Users\Public\Instrument'; MDIR  
 'New\_Directory'  
 Create an additional directory  
 C:\Users\Public\Instrument\New\_Directory.

**Usage:** Setting only

### MMEMory:MOVE <SourceFile>, <NewFile>

Moves a file to the indicated directory and stores it under the file name specified, if any. If <NewFile> contains no path indication, the command renames the file without moving it.

#### Setting parameters:

<SourceFile>

<NewFile>

String parameters to specify the name and the path of the file to be copied and the name and the path of the new file.

**Example:** MMEM:MOVE 'C:\Users\Public\Documents  
 \Rohde-Schwarz\Vna\RecallSets\SET1.znx', 'D:'  
 Move file Set1.znx in directory C:  
 \Users\Public\Documents  
 \Rohde-Schwarz\Vna\RecallSets to an external storage  
 medium, mapped to drive D:.

**Usage:** Setting only

### MMEMory:MSIS <Drive>

Sets/gets the *current drive* for MMEMory commands (MSIS = mass storage identification string).

Other MMEMory commands interpret paths starting with a "\" relative to this drive.

MMEMory:MSIS <Drive> is equivalent to MMEMory:CDIRectory <Drive>. In particular, it sets the current directory to the base directory of the specified drive.

#### Parameters:

<Drive> Drive letter, followed by a colon, e.g. 'D:'

**Example:** `MMEMemory:CDIRectory DEFault`  
 selects the default directory  
`C:\Users\Public\Documents\Rohde-Schwarz\Vna.`  
`MMEMemory:MSIS?`  
 returns `C:.`  
`MMEMemory:CATalog? 'hardcopy'`  
 lists the contents of  
`C:\Users\Public\Documents\Rohde-Schwarz\Vna\`  
`hardcopy.`  
`MMEMemory:CATalog? '\hardcopy'`  
 lists the contents of `D:\hardcopy.`

### **MMEMemory:NAME** <Filename>

Defines a name for a file which can be used to store the printer output. The file is created when it is selected as a printer destination (`HCOPY:DESTination 'MMEM'`).

#### **Parameters:**

<Filename> String parameter to specify the file name. The supported file formats are \*.wmf, \*.emf, \*.bmp, \*.png; see command `HCOPY:DEVICE:LANGUAGE`. The specified directory must exist, otherwise no file can be generated. If no path is specified the analyzer uses the current directory, to be queried with `MMEMemory:CDIRectory?`.  
 \*RST: 'Hardcopy'

**Example:** `MMEM:NAME 'C:`  
`\Users\Public\Screenshots\PLOT1.BMP'`  
 Define a printer file name, to be stored in the existing directory  
`C:\Users\Public\Screenshots` (without creating the file).  
`HCOP:DEST 'MMEM'; :HCOP`  
 Select "Print to file" and create the printer file specified before.

### **MMEMemory:RDIRectory** <Directory>

Removes an existing directory from the mass memory storage system.

#### **Setting parameters:**

<Directory> String parameter to specify the directory.

**Example:** `MMEM:RDIR 'C:`  
`\Users\Public\NetworkService\Application Data'`  
 Removes the specified directory.

**Usage:** Setting only

### **MMEMemory:STORE:CABLE** <OutputDir>

Saves all predefined and user-defined Distance to Fault (DtF) cable types to the specified output directory.

Each DtF cable type is stored in a separate ASCII file < cable name >. rsc. The command silently overwrites files of the same name previously existing in the output directory.

**Setting parameters:**

<OutputDir> Output Directory, must be created before the command is executed

**Example:** see [MMEMory:LOAD:CABLE](#) on page 848

**Usage:** Setting only

**Options:** R&S ZND-K3

**Manual operation:** See "[Add / Delete](#)" on page 501

**MMEMory:STORe:CKIT** <CalKitName>, <CalKitFile>

Stores the data of a calibration kit to a specified file. The calibration kit is identified by its name.

**Setting parameters:**

<CalKitName> Name of a user-defined calibration kit available on the analyzer.  
**Tip:** It is not possible to modify or store predefined or ideal kits.

<CalKitFile> String parameter to specify the name and directory of the cal kit file to be created. The file is a network analyzer-specific cal kit file with the extension \*.calkit.  
If no path is specified the analyzer searches the current directory, to be queried with [MMEMory:CDIRectory](#)

**Example:**

```
MMEM:LOAD:CKIT 'C:\Users\Public\Documents
\Rohde-Schwarz\Vna\Calibration\Kits\New Kit
1.calkit'
```

Load the previously created cal kit file New Kit 1.calkit from the default cal kit directory.

```
... :MMEM:STOR:CKIT 'New Kit 1', 'C:
\Users\Public\Documents
\Rohde-Schwarz\Vna\Calibration\Kits\New Kit
1.calkit'
```

Store the data for the user-defined cal kit "New Kit 1" and overwrite the cal kit file New Kit 1.calkit.

**Usage:** Setting only

**Manual operation:** See "[Import Cal Kit... / Export Cal Kit...](#)" on page 405

**MMEMory:STORe:CKIT:WLABel** <CalKitName>, <KitLabel>, <CalKitFile>

Stores the data of a calibration kit to a specified file. The calibration kit is identified by its name and label.



**Setting parameters:**

|              |                                                                                                                                                                                                                                                                                           |
|--------------|-------------------------------------------------------------------------------------------------------------------------------------------------------------------------------------------------------------------------------------------------------------------------------------------|
| <CalKitName> | Name of a user-defined calibration kit available on the analyzer.<br><b>Tip:</b> It is not possible to modify or store predefined or ideal kits.                                                                                                                                          |
| <KitLabel>   | Label of the calibration kit, usually its serial number.                                                                                                                                                                                                                                  |
| <CalKitFile> | String parameter to specify the name and directory of the cal kit file to be created. The file is a NWA-specific cal kit file with the extension *.calkit.<br>If no path is specified the analyzer searches the current directory, to be queried with <a href="#">MMEemory:CDIRectory</a> |

**Example:** See [\[SENSe:\]CORRection:CKIT:LLaBel](#)

**Usage:** Setting only

**MMEemory:STORe:CMAP <ColorSchemeFile>**

Stores a color scheme to a specified VNA color scheme file.

**Setting parameters:**

|                   |                                                                                                                                                                                                                                                                                                                                              |
|-------------------|----------------------------------------------------------------------------------------------------------------------------------------------------------------------------------------------------------------------------------------------------------------------------------------------------------------------------------------------|
| <ColorSchemeFile> | String parameter to specify the name and directory of the color scheme file to be created. If no path is specified the analyzer uses the current directory, to be queried with <a href="#">MMEemory:CDIRectory?</a> . The default extension (manual control) for color scheme files is *.ColorScheme, although other extensions are allowed. |
|-------------------|----------------------------------------------------------------------------------------------------------------------------------------------------------------------------------------------------------------------------------------------------------------------------------------------------------------------------------------------|

**Example:** See [MMEemory:LOAD:CMAP](#)

**Usage:** Setting only

**Manual operation:** See "[Recall... / Save...](#)" on page 514

**MMEemory:STORe:CORRection <Channel>, <CalGroupFile>**

Copies the correction data of channel <Channel> to the cal pool, generating a new correction data file (cal group). The file has the extension \*.cal and is stored in the C:\Users\Public\Documents\Rohde-Schwarz\Vna\Calibration\Data directory.

**Setting parameters:**

|                |                                                                                                                                                                                                                                                                             |
|----------------|-----------------------------------------------------------------------------------------------------------------------------------------------------------------------------------------------------------------------------------------------------------------------------|
| <Channel>      | Channel number                                                                                                                                                                                                                                                              |
| <CalGroupFile> | String parameter to specify the name of the created cal group file. There is no need to specify the directory path and file extension; the analyzer uses the default cal pool directory C:\Users\Public\Documents\Rohde-Schwarz\Vna\Calibration\Data and a *.cal extension. |

**Example:** See [MMEemory:LOAD:CORRection](#)

**Usage:** Setting only

**Manual operation:** See ["Add / Add All... / Replace / Apply / Apply to All"](#) on page 424

---

### MMEMory:STORe:CORRection:TCOefficient<Ch> <PmclFile>

Saves the power meter (two-port) transmission coefficients of channel <Ch> to a power meter correction list file.

**Suffix:**

<Ch> Channel number

**Setting parameters:**

<PmclFile> String parameter specifying the name and directory of the created power meter correction list file. The file extension \*.pmcl is mandatory.

If no path is specified, the analyzer searches the current directory, to be queried with [MMEMory:CDIRectory](#)

\*RST: n/a

**Example:**

See [SOURce<Ch>:POWer<PhyPt>:CORRection:TCOefficient:CALibration](#)

**Usage:**

Setting only

**Manual operation:** See ["Recall... / Save..."](#) on page 421

---

### MMEMory:STORe:LIMit <TraceName>, <LimLineFile>

Saves the limit lines associated to a specified trace to a limit line file. Limit lines are created using the [CALCulate<Chn>:LIMit...](#) commands.

**Setting parameters:**

<TraceName> Name of an existing trace in the active recall set (string parameter) for which a limit line definition exists.

<LimLineFile> String parameter to specify the name and directory of the created limit line file. The default extension (manual control) for limit line files is \*.limit, although other extensions are allowed.

If no path is specified the analyzer searches the current directory, to be queried with [MMEMory:CDIRectory](#)

**Example:**

See [MMEMory:LOAD:LIMit](#)

**Usage:**

Setting only

**Manual operation:** See ["Recall... / Save..."](#) on page 310

---

### MMEMory:STORe:MARKer <AsciiFile>

Saves the values of all markers to an ASCII file.

**Setting parameters:**

<AsciiFile> String parameter to specify the name and directory of the created ASCII file. The default extension (manual control) for marker files is \*.txt, although other extensions are allowed. If no path is specified the analyzer searches the current directory, to be queried with [MMEMemory:CDIRectory](#)

**Example:**

```
*RST
Reset the analyzer, creating the default trace no. 1 in channel no. 1.
CALC:MARK ON; MARK:X 1GHz
Create marker no. 1 and place it to 1 GHz.
CALC:MARK2 ON; MARK2:X 2GHz
Create a second marker and place it to 2 GHz.
MME:STOR:MARK 'Marker.txt'
Store the marker values to an ASCII file. The file contains both marker values, e.g.:
Trc1 S21
Mkr 1 1.000000 GHz -4.900 dB
Mkr 2 2.000000 GHz -6.807 dB
```

**Usage:** Setting only

**Manual operation:** See ["Export Markers"](#) on page 328

**MMEMemory:STORe:RIPPlE** <TraceName>, <RippleLimFile>

Saves the ripple limits associated with a specified trace to a ripple limit file. Ripple limit definitions are created using the `CALCulate<Chn>:RIPPlE...` commands.

**Setting parameters:**

<TraceName> Name of an existing trace in the active setup (string parameter) for which a ripple limit definition exists.

<RippleLimFile> String parameter to specify the name and directory of the created ripple limit file. The default extension (manual control) for ripple limit files is \*.ripple, although other extensions are allowed. If no path is specified the analyzer searches the current directory, to be queried with [MMEMemory:CDIRectory](#)

**Example:** See [MMEMemory:LOAD:LIMit](#)

**Usage:** Setting only

**Manual operation:** See ["Recall Ripple Test.../Save Ripple Test..."](#) on page 317

**MMEMemory:STORe:SEGMENT** <Channel>, <SweepSegFile>

Saves the sweep segment definition of the related channel to a an ASCII file. Sweep segments are defined using `[SENSe:]SEGMENT<Seg>...` commands.

**Setting parameters:**

|                |                                                                                                                                                                                                                                                                                                                                                       |
|----------------|-------------------------------------------------------------------------------------------------------------------------------------------------------------------------------------------------------------------------------------------------------------------------------------------------------------------------------------------------------|
| <Channel>      | Channel number                                                                                                                                                                                                                                                                                                                                        |
| <SweepSegFile> | String parameter to specify the name and directory of the created sweep segment file. The default extension (manual control) for sweep segment files is <code>*.SegList</code> , although other extensions are allowed.<br>If no path is specified the analyzer searches the current directory, to be queried with <a href="#">MMEMory:CDIRectory</a> |

**Example:** See [MMEMory:LOAD:SEGMENT](#)

**Usage:** Setting only

**Manual operation:** See "[Import.../Export...](#)" on page 363

**MMEMory:STORe:STATe** <Compatibility>, <RecallSetFile>

Stores the configuration data of the current recall set to the specified recall set file.

`MMEMory:STORe:STATe` also renames the current recall set. See example for `MMEMory:LOAD:STATe`.

**Setting parameters:**

|                 |                                                                                                                                                                                                                                                                                                                                                                                                      |
|-----------------|------------------------------------------------------------------------------------------------------------------------------------------------------------------------------------------------------------------------------------------------------------------------------------------------------------------------------------------------------------------------------------------------------|
| <Compatibility> | 1 (this value is used for compatibility with the SCPI standard but ignored).                                                                                                                                                                                                                                                                                                                         |
| <RecallSetFile> | String parameter to specify the absolute or relative path of the created recall set file. Relative paths are evaluated relative to the current directory (see <a href="#">MMEMory:CDIRectory</a> ).<br>The default extension for recall set files is <code>znx</code> . Unless you specify <code>znxml</code> as file name extension, recall sets are always stored in <code>znx</code> file format. |

**Example:** See [MMEMory:LOAD:STATe](#)

**Usage:** Setting only

**Manual operation:** See "[Save](#)" on page 487

**MMEMory:STORe:TRACe** <TraceName>, <TraceFile>[, <FormatInd>[, <Format>[, <DecSeparator>[, <FieldSeparator>]]]]

Stores the trace data of a specified data trace to a trace file. Traces are created using the [CALCulate<Ch>:PARAmeter:SDEFine](#) command.

**Tip:** `*.s<n>p` Touchstone files ( $<n> = 1, 2, 3, \dots$ ) are intended for a complete set of  $<n>$ -port S-parameters. Data export fails if the active channel does not contain the full set of  $<n>^2$  traces or if the involved ports are not numbered consecutively, starting with port 1. If the necessary traces are available, '`<trc_name>`' can be the name of any of the traces. To create Touchstone files while less than  $<n>^2$  single-ended traces are available, use [MMEMory:STORe:TRACe:PORTs](#).

**Setting parameters:**

|                  |                                                                                                                                                                                                                                                                                                                                                                                                                                                                                                                       |
|------------------|-----------------------------------------------------------------------------------------------------------------------------------------------------------------------------------------------------------------------------------------------------------------------------------------------------------------------------------------------------------------------------------------------------------------------------------------------------------------------------------------------------------------------|
| <TraceName>      | Name of an existing data trace in the active recall set (string parameter).                                                                                                                                                                                                                                                                                                                                                                                                                                           |
| <TraceFile>      | String parameter to specify the name and directory of the created trace file. Several file formats for trace files are supported. The file extensions *.s<n>p, *.csv, and *.dat for Touchstone, ASCII, and Matlab files are mandatory. To generate a multiport Touchstone file *.s2p, *.s3p..., the channel must contain traces for the full set of S-parameters; the '<trc_name>' is ignored. If no path is specified the analyzer uses the current directory, to be queried with <code>MMEMory:CDIRectory?</code> . |
| <FormatInd>      | FORMatted   UNFormatted<br>UNFormatted - unformatted data export specified by the second optional parameter.<br>FORMatted - formatted data export (for *.csv and *.dat files only).<br>If the first optional parameter is omitted, the command stores unformatted data.                                                                                                                                                                                                                                               |
| <Format>         | COMPLex   LINPhase   LOGPhase<br>COMPLex - complex values (real and imaginary part)<br>LINPhase - linear magnitude and phase.<br>LOGPhase - dB-magnitude and phase.<br>If the second optional parameter is omitted, the command stores complex data.                                                                                                                                                                                                                                                                  |
| <DecSeparator>   | POINT   COMMa<br>POINT - decimal separator: point.<br>COMMa - decimal separator: comma.<br>If the third optional parameter is omitted, points are used.                                                                                                                                                                                                                                                                                                                                                               |
| <FieldSeparator> | SEMicolon   COMMa   TABulator   SPACe<br>SEMicolon - field separator: semicolon<br>COMMa - field separator: comma.<br>TABulator - field separator: tabulator.<br>SPACe - field separator: space.<br>If the fourth optional parameter is omitted, semicolons are used.                                                                                                                                                                                                                                                 |

**Example:** See [MMEMory:LOAD:TRACe](#)

**Usage:** Setting only

**Manual operation:** See "[Save](#)" on page 302

---

**MMEMory:STORE:TRACe:CHANnel** <Channel>, <TraceFile>[, <FormatInd>[, <Format>[, <DecSeparator>[, <FieldSeparator>]]]]

Stores the trace data of all data traces in the specified channel to a trace file. Traces are created using the [CALCulate<Ch>:PARAmeter:SDEFine](#) command.

**Tip:** \*.s<n>p Touchstone files (<n> = 1, 2, 3, ...) are intended for a complete set of <n>-port S-parameters. Data export fails if the active channel does not contain the full set of <n><sup>2</sup> traces.

**Setting parameters:**

|                  |                                                                                                                                                                                                                                                                                                                                                                                                                                                                                       |
|------------------|---------------------------------------------------------------------------------------------------------------------------------------------------------------------------------------------------------------------------------------------------------------------------------------------------------------------------------------------------------------------------------------------------------------------------------------------------------------------------------------|
| <Channel>        | Channel number in the active recall set. ALL means that a separate file is created for each channel in the active recall set.                                                                                                                                                                                                                                                                                                                                                         |
| <TraceFile>      | String parameter to specify the name and directory of the created trace file. Several file formats for trace files are supported. The file extensions *.s<n>p, *.csvc, and *.dat for Touchstone, ASCII, and Matlab files are mandatory. To generate a multiport Touchstone file *.s2p, *.s3p . . . , the channel must contain traces for the full set of S-parameters. If no path is specified the analyzer uses the<br>C:\Users\Public\Documents\Rohde-Schwarz\Vna\Traces directory. |
| <FormatInd>      | FORMatted   UNFormatted<br>UNFormatted - unformatted data export specified by the second optional parameter.<br>FORMatted - formatted data export (for *.csv and *.dat files only).<br>If the first optional parameter is omitted, the command stores unformatted data.                                                                                                                                                                                                               |
| <Format>         | COMPLex   LINPhase   LOGPhase<br>COMPLex - complex values (real and imaginary part)<br>LINPhase - linear magnitude and phase.<br>LOGPhase - dB-magnitude and phase.<br>If the second optional parameter is omitted, the command stores complex data.                                                                                                                                                                                                                                  |
| <DecSeparator>   | POINT   COMMa<br>POINT - Decimal separator: point.<br>COMMa - Decimal separator: comma.<br>If the third optional parameter is omitted, points are used.                                                                                                                                                                                                                                                                                                                               |
| <FieldSeparator> | SEMicolon   COMMa   TABulator   SPACe<br>SEMicolon - Field separator: semicolon<br>COMMa - field separator: comma.<br>TABulator - field separator: tabulator.<br>SPACe - field separator: space.<br>If the third optional parameter is omitted, semicolons are used.                                                                                                                                                                                                                  |

**Example:**            \*RST; :CONF:TRAC:NAME?  
 Reset the instrument, creating a default channel no 1 and a default trace Trc1.  
 CALC:PAR:DEF:SGR 1,2  
 Create four traces to measure the two-port S-parameters  $S_{11}$ ,  $S_{12}$ ,  $S_{21}$ ,  $S_{22}$ . The traces are not displayed.  
 MMEM:STOR:TRAC:CHAN 1, 'C:\Users\Public\Documents\Rohde-Schwarz\Vna\Traces\Chn1.csv'  
 Store all trace data of channel 1 to a trace file.  
 MMEM:STOR:TRAC:CHAN 1, 'C:\Users\Public\Documents\Rohde-Schwarz\Vna\Traces\Chn1.s2p'  
 Store the four S-parameter traces to a two-port Touchstone file. The Touchstone file will not contain the default trace Trc1.

**Usage:**            Setting only

**Manual operation:** See "Save" on page 302

---

**MMEMory:STORe:TRACe:OPTion:BALanced** <Boolean>

**MMEMory:STORe:TRACe:OPTion:SYMMetric** <Boolean>

This command enables/disables the export of balanced (and mixed-mode) S-parameters for [MMEMory:STORe:TRACe:PORTs](#).

**Parameters:**

<Boolean>

---

**MMEMory:STORe:TRACe:OPTion:COMMeNt** <Comment>

Defines a comment to be added to (the comment section of) exported trace files.

This is a global setting, i.e. the comment string is used for each trace export in every open recall set.

**Parameters:**

<Comment>            Comment string. If empty, no comment will be added.

**Manual operation:** See "Comment Added to File" on page 302

---

**MMEMory:STORe:TRACe:OPTion:DECimals:STIMulus** <NumDecimals>

**MMEMory:STORe:TRACe:OPTion:DECimals:DATA** <NumDecimals>

Defines the number of decimal places for stimulus and data values in all supported trace data files (Touchstone, ASCII, MatLab)

**Note** that in the current implementation of the Touchstone file export, only the L11 file format supports independent settings for stimulus and data values (see [MMEMory:STORe:TRACe:OPTion:FORMat](#)). For the F11 and F20 formats, the DATA number of digits is used for both stimulus and data values.

**Parameters:**

<NumDecimals>        Range:        1 to 15

**Manual operation:** See ["Decimal Places"](#) on page 300

---

**MMEMory:STORe:TRACe:OPTion:FORMat** <TS\_Frmt>

Selects the [file format](#) to be generated during Touchstone export.

**Parameters:**

|            |                                                                                                                                                    |
|------------|----------------------------------------------------------------------------------------------------------------------------------------------------|
| <TS_Frmt>  | F11   F20   L11                                                                                                                                    |
| <b>F11</b> | Trace output according to Touchstone standard 1.1 (new library)                                                                                    |
| <b>F20</b> | Trace output according to Touchstone standard 2.0 (new library)                                                                                    |
| <b>L11</b> | Legacy Touchstone 1.1 output                                                                                                                       |
|            | F11 and L11 slightly differ w.r.t. casing, number formatting and comments. F20 adds keywords etc. introduced with Touchstone standard version 2.0. |

**Manual operation:** See ["File Format"](#) on page 300

---

**MMEMory:STORe:TRACe:OPTion:PLUS** <arg0>

This command defines how positive numbers are prefixed during Touchstone file export: by a leading space, a plus sign or not at all.

**Parameters:**

|        |                     |
|--------|---------------------|
| <arg0> | SPACe   PLUS   VOID |
|--------|---------------------|

**Manual operation:** See ["Positive Number Prefix"](#) on page 527

---

**MMEMory:STORe:TRACe:OPTion:SSEParator** <Boolean>

This command defines whitespace insertion during Touchstone file export.

If set to ON, separator lines are skipped, i.e. the content parts are no longer separated by blank lines.

**Parameters:**

|           |
|-----------|
| <Boolean> |
|-----------|

**Manual operation:** See ["Skip Separator Lines"](#) on page 528

---

**MMEMory:STORe:TRACe:OPTion:TABS** <Boolean>

This command defines whitespace insertion during Touchstone file export.

If set to ON, columns are separated by tabs rather than spaces.

**Parameters:**

|           |
|-----------|
| <Boolean> |
|-----------|

**Manual operation:** See ["Use TAB \(instead of blanks\)"](#) on page 527



**MMEMory:STORe:TRACe:OPTion:TRIM** <Boolean>

This command defines whitespace insertion during Touchstone file export.

If set to ON, whitespace at the beginning of each line is removed.

**Parameters:**

<Boolean>

**Manual operation:** See ["Trim Leading Whitespace"](#) on page 527

**MMEMory:STORe:TRACe:PORTs** <Channel>, <TouchstoneFile>, <Format>[, <ModelImpedance>, <Port>[, <Port>]...]

Generates an `snp` Touchstone file, where `n` is the number of specified ports.

If the specified physical ports comprise at least one balanced port and [MMEMory:STORe:TRACe:OPTion:BALanced](#) is ON, the Touchstone file contains the full set of mixed mode S-parameters. Otherwise it contains the full set of single-ended S-parameters. Both sets have a size of  $n^2$ .

The command fails unless the conditions for Touchstone file export are met; see ["Conditions for Touchstone File Export"](#) on page 136. Traces are created using the [CALCulate<Ch>:PARAmeter:SDEFine](#) command.

**Setting parameters:**

|                     |                                                                                                                                                                                                                                                                                                                  |
|---------------------|------------------------------------------------------------------------------------------------------------------------------------------------------------------------------------------------------------------------------------------------------------------------------------------------------------------|
| <Channel>           | Channel number in the active recall set.                                                                                                                                                                                                                                                                         |
| <TouchstoneFile>    | String parameter to specify the name and directory of the created Touchstone file. The file extension <code>*.snp</code> for an <code>n</code> -port Touchstone file is mandatory.<br>If no path is specified the analyzer searches the current directory, to be queried with <a href="#">MMEMory:CDIRectory</a> |
| <Format>            | COMPLex   LINPhase   LOGPhase<br>COMPLex - complex values (real and imaginary part).<br>LINPhase - Linear magnitude and phase.<br>LOGPhase - dB-magnitude and phase.                                                                                                                                             |
| <ModelImpedance>    | CIMPedance   PIMPedance<br><b>CIMPedance</b> (default, if omitted): normalize to a common target impedance of 50 $\Omega$<br><b>PIMPedance</b> : normalize to the individual port reference impedances<br>See <a href="#">"Renormalization of S-Parameters"</a> on page 136.                                     |
| <Port>, <Port>, ... | Physical port numbers                                                                                                                                                                                                                                                                                            |
| <Port>              |                                                                                                                                                                                                                                                                                                                  |

- Example:** Suppose that a full two-port calibration for ports 1 and 2 and channel 1 has been performed, and that a DUT with two balanced ports is connected. The analyzer measures an arbitrary mixed mode S-parameter.
- ```
MMEM:STOR:TRAC:PORT 1, 'Test_CIMP.s2p',
COMPLex, CIMPedance, 1, 2
```
- Calculate all single-ended S-parameters, renormalize them to the common target impedance and store them to a two-port Touchstone file.
- ```
MMEM:STOR:TRAC:PORT 1, 'Test_PIMP.s2p',
COMPLex, PIMPedance, 1, 2
```
- Calculate all single-ended S-parameters, renormalize them to the individual port reference impedances and store them to a two-port Touchstone file.
- Usage:** Setting only
- Manual operation:** See ["Save"](#) on page 302

### 8.3.12 OUTPut Commands

The `OUTPut...` commands control the characteristics of the analyzer's output ports.

|                                                                      |     |
|----------------------------------------------------------------------|-----|
| <code>OUTPut:UPORT:ECBits</code> .....                               | 878 |
| <code>OUTPut&lt;Ch&gt;[:STATe]</code> .....                          | 878 |
| <code>OUTPut&lt;Ch&gt;:UPORT:SEGMent&lt;Seg&gt;:STATe</code> .....   | 879 |
| <code>OUTPut&lt;Ch&gt;:UPORT:SEGMent&lt;Seg&gt;[:VALue]</code> ..... | 879 |
| <code>OUTPut&lt;Ch&gt;:UPORT[:VALue]</code> .....                    | 881 |

---

#### `OUTPut:UPORT:ECBits` <Boolean>

Defines the usage of pins 16 to 19 of the USER PORT connector.

**Parameters:**

- <Boolean>
- ON – channel bits 4 to 7
  - OFF – drive port 1 to 4
  - \*RST: ON

**Example:** See `OUTPut<Ch>:UPORT[:VALue]`

**Manual operation:** See ["Pin 16 - 19"](#) on page 526

---

#### `OUTPut<Ch>[:STATe]` <Boolean>

Turns the internal source power at all ports on or off.

**Suffix:**

- <Ch>
- Channel number. This suffix is ignored; the setting is valid for all channels.

**Parameters:**

<Boolean> ON | OFF - switch the power on or off.  
\*RST: ON

**Example:**

OUTP OFF  
Turn off the RF source power.

**Manual operation:** See ["RF Off All Channels"](#) on page 347

**OUTPut<Ch>:UPORt:SEGMent<Seg>:STATe** <Boolean>

Enables or disables segment bits for the sweep segments in channel no. <Ch>; see `OUTPut<Ch>:UPORt:SEGMent<Seg>[:VALue]`. The command is valid for segmented frequency sweep.

**Suffix:**

<Ch> Channel number.  
<Seg> Sweep segment number. This suffix is ignored; the setting is valid for all segments.

**Parameters:**

<Boolean> ON | OFF - Enables or disables channel bits.  
\*RST: OFF

**Example:**

See `OUTPut<Ch>:UPORt:SEGMent<Seg>[:VALue]` on page 879

**Manual operation:** See ["Optional Columns"](#) on page 364

**OUTPut<Ch>:UPORt:SEGMent<Seg>[:VALue]** <BinValue>

Sets or queries a sweep segment-dependent four-bit binary value to control four independent output signals at the USER PORT connector (lines 16, 17, 18, 19). The output signals are 3.3 V TTL signals which can be used to differentiate between up to 16 independent analyzer states for each channel. The command is valid for segmented frequency sweeps. It is analogous to the channel-dependent command `OUTPut<Ch>:UPORt[:VALue]`.

The bits for the sweep segments must be enabled explicitly using `OUTPut<Ch>:UPORt:SEGMent:STATe`.

**Segment bit definition and activation**

The segment bits have the following properties:

- After a \*RST of the analyzer all segment bits are set to zero; no signal is applied to pins 16 to 19 of the USER PORT connector.
- The value defined with `OUTPut<Ch>:UPORt:SEGMent<Seg>[:VALue]` is assigned to segment no. <Seg> in channel no. <Ch>.
- The signals at the USER CONTROL connector reflect the segments bits of the currently measured segment.

- The signals are switched on as soon as a measurement in a segment with non-zero segment bits is started. They are changed whenever a segment with different segment bits is measured.
- The signals at the USER PORT connector are maintained after the analyzer enters the hold state. This happens in single sweep mode after all sweep sequences have been terminated.

**Tip:**

You can use the active segment number as a parameter for `OUTPut<Ch>:UPOrt:SEGMENT<Seg>[:VALue]` and monitor the measurement in up to 16 different segments per channel at the USER PORT connector; see example below. You can also use the USER PORT output signals as segment-dependent trigger signals for external devices. Use `CONTRol:AUXiliary:C[:DATA]` to transfer the four bit value in decimal representation.

**Suffix:**

<Ch> Channel number.  
 <Seg> Sweep segment number

**Parameters:**

<BinValue> Binary value. The transferred values correspond to the following states of the USER CONTROL connector:  
 #B0000 - no signal at any of the four pins 16, 17, 18, 19  
 #B0001 - output signal at pin 16  
 #B0010 - output signal at pin 17  
 #B0011 - output signal at pin 16 and 17  
 ...  
 #B1111 - output signal at pin 16, 17, 18 and 19  
 Range: #B0000 to #B1111 (for setting command), 0 to 15 (query)  
 \*RST: #B0000 (0)

**Example:**

```
*RST; :SEGM:INS 1MHZ, 1.5MHZ, 111, -21DBM,
0.5S, 0, 10KHZ
```

Create a sweep segment no. 1 with a sweep range between 1.0 MHz and 1.5 MHz.

```
SWE:TYPE SEGM
```

Set the segmented frequency sweep active.

```
OUTP:UPOR:SEGM:STAT ON
```

Enable segment bits.

```
OUTP:UPOR:SEGM1 #B0001
```

Assign the segment bit value #B0001 to segment no. 1. The output signal at pin 16 is switched on while the first segment is measured.

```
SEGM2:ADD
```

Create a second sweep segment. The frequency range of the second segment will be between 1.5 MHz and the maximum frequency of the analyzer.

```
OUTP:UPOR:SEGM2 #B0010
```

Assign the segment bit value #B0010 to segment no. 2. While the analyzer measures the second segment, the output signal changes from pin 16 to pin 17.

**Manual operation:** See "[Optional Columns](#)" on page 364

---

**OUTPut<Ch>:UPORt[:VALue] <BinValue>**

Sets or queries a channel-dependent eight-bit binary value to control eight independent output signals at the USER PORT connector (lines 8, 9, 10, 11 and lines 16, 17, 18, 19). The output signals are 3.3 V TTL signals which can be used to differentiate between up to 255 independent analyzer states. `OUTPut<Ch>:UPORt[:VALue]` itself does not change the analyzer state.

**Channel bit definition and activation**

The channel bits have the following properties:

- After a `*RST` of the analyzer all channel bits (including the value for the active, sweeping channel no. 1) are set to zero; no signal is applied to pins 8 to 11 and 16 to 19 of the USER PORT connector.
- The value defined with `OUTPut<Ch>:UPORt[:VALue]` is assigned to channel no. <Ch>.
- The signals at the USER PORT connector reflect the channel bits of the **measuring** channel, i.e. the channel for which the analyzer performs a sweep. This channel is not necessarily identical with the active channel.
- The signals are switched on as soon as a measurement (sweep) in a channel with non-zero channel bits is started. They are changed whenever a channel with different channel bits becomes the measuring channel.
- The signals at the USER PORT connector are maintained after the analyzer enters the hold state. This happens if all channels use single sweep mode and if all sweep sequences have been terminated.

- Pins 16 to 19 may be reserved for monitoring the drive ports 1 to 4 of the analyzer (`OUTPut<Ch>:UPORt:ECBits OFF`). This leaves up to 16 different monitored channel states.

**Tip:** You can use the active channel number as a parameter for `OUTPut<Ch>:UPORt[:VALue]` and monitor the activity of up to 255 different channels at the USER PORT connector; see example below. You can also use the USER PORT output signals as channel-dependent (or drive port-dependent) trigger signals for external devices. Furthermore you can use `CONTRol:AUXiliary:C[:DATA]` to transfer the eight bit value in decimal representation.

**Suffix:**

<Ch> Channel number

**Parameters:**

<BinValue> Binary value. The values correspond to the following states of the USER PORT connector:

- #B00000000 - no signal at any of the eight pins 8, 9, 10, 11, 16, 17, 18, 19
- #B00000001 - output signal at pin 8
- #B00000010 - output signal at pin 9
- #B00000011 - output signal at pins 8 and 9
- ...
- #B11111111 - output signal at pins 8, 9, 10, 11, 16, 17, 18, 19

Range: #B00000000 to #B11111111 (for setting command),  
0 to 255 (query)

\*RST: #B00000000 (0)

**Example:**

```
*RST; :OUTP1:UPOR #B00000001
```

Assign the channel bit value #B00000001 to the active channel no. 1. The analyzer performs a measurement in channel no. 1, therefore the output signal at pin 8 is switched on.

```
CONF:CHAN2:STAT ON; OUTP2:UPOR #B00000010
```

Create channel no. 2, causing it to become the active channel, and assign the channel bit value #B00000010. The analyzer performs no measurement in channel no. 2, therefore the output signal is not changed.

```
CALC2:PAR:SDEF 'Ch2Tr1', 'S11'
```

Create a trace named 'Ch2Tr1' and assign it to channel 2. While the analyzer measures in channel 2, the output signal changes from pin 8 to pin 9.

```
OUTP:UPOR:ECB OFF
```

Reserve pin 16 to 19 for monitoring the drive ports of the analyzer.

**Manual operation:** See "[Channel Bits \(Decimal\)](#)" on page 526

### 8.3.13 PROGram Commands

The PROGram... commands control external application programs that can be run on the analyzer.

|                                       |     |
|---------------------------------------|-----|
| PROGram[:SElected]:EXECute.....       | 883 |
| PROGram[:SElected]:INIMessage.....    | 884 |
| PROGram[:SElected]:INIPParameter..... | 884 |
| PROGram[:SElected]:NAME.....          | 885 |
| PROGram[:SElected]:RETVAl?.....       | 886 |
| PROGram[:SElected]:WAIT.....          | 886 |

---

#### PROGram[:SElected]:EXECute <AppName>

Starts an application process or open a file using an application available on the analyzer.

Use the command sequence `PROGram[:SElected]:WAIT? ; PROGram[:SElected]:RETVAl?` to query the return value (see example below).

**Note:** It is not possible to run several programs simultaneously. If the command `PROGram[:SElected]:EXECute ...` is sent while a previously started program is still executed, the analyzer generates a SCPI error -100, "Command error...".

#### Tip: Executing batch files; command prompt

When executing batch scripts or other DOS applications, the analyzer does not display any DOS windows; the screen is left for the vector network analyzer (VNA) application. The same applies to the Windows NT command prompt (`cmd.exe`). To access the command prompt, proceed as follows:

- Create a batch file (e.g. `Start_cmd.bat`) containing the command line `start cmd.exe` and store the file to `C:\Winnt\system32`.
- Execute the batch file: `PROG:EXEC 'C:\winnt\system32\Start_cmd.bat'`

The command prompt window is displayed in front of the VNA application. You can also open several command prompt windows simultaneously.

#### Setting parameters:

<AppName> String variable containing the name and path of an application program to be executed or of a file to be opened. The path can be defined as an absolute path (e.g. 'c:\...') or relative to the current directory (`MMEMory:CDIRectory`). Blanks in the <AppName> can be used to separate the application name from (optional) parameters.

**Example:**

```

PROG:SELected:NAME PROG
Select general program execution.
PROG:SELected:EXECute 'Exit42.bat'
Run batch script Exit42.bat.
PROG:SELected:WAIT?
Lock command execution and manual control of the analyzer
until the batch job has finished. This is required for
PROG:SELected:RETVal?
Get the return value. The answer is ... 42.

```

**Usage:** Setting only

### **PROG:SELected]:INIMessage** <IniFile>[, <SendValue>]

Writes a message <SendValue> into the preferences (\*.ini) file specified by <IniFile>. The message is entered into the [MESSAGE] section using the fixed key `Send`; the value for the fixed key `Receive` is set to an empty string.

The query reads the value associated with the fixed key `Receive` from the [MESSAGE] section of the preferences file specified by <IniFile>. If no value exists for that key, the query returns an empty string.

Both commands can be used to establish a simple file-based two-way communication mechanism to an external application launched by `PROG[:SELected]:EXECute`; see example.

#### **Parameters:**

<IniFile> Name and path of the \*.ini file. The \*.ini extension may be omitted as it is created automatically by the command. The specified path/directory must exist. If the \*.ini file does not exist, it is created.

<SendValue> Value for the fixed key `Send`.

**Example:**

```

PROG:INIM 'c:\preferences\myapp', 'this is a
message'
Write the string this is a message into the file
c:\preferences\myapp.ini. The contents of the file look
like:
[MESSAGE] Send="this is a message" Receive=
Suppose the external program writes the string
this is a response to the Receive key (and possibly dele-
tes the contents of the Send key.
PROG:INIM? 'c:\preferences\myapp'
Query the value of the key Receive in the *.ini file. The
response is "this is a response".

```

### **PROG:SELected]:INIParameter** <IniFile>{ , <Key>,<Value> | '<Value>'

Defines and writes one or several key/value pairs into the preferences file (\*.ini) specified by <file\_path>. The information is entered into the [PARAMETER] section.



This command can be used to supply information to an external application launched by `:PROGram[:SElected]:EXECute`.

The query must be sent with a single `<Key>` value. It reads the value associated with the key from the `[PARAMETER]` section of the preferences file specified by `<file_path>`. If the key/value pair does not exist, the query returns an empty string.

**Parameters:**

|                              |                                                                                                                                                                                                                                                     |
|------------------------------|-----------------------------------------------------------------------------------------------------------------------------------------------------------------------------------------------------------------------------------------------------|
| <code>&lt;IniFile&gt;</code> | Name and path of the <code>*.ini</code> file. The <code>*.ini</code> extension may be omitted as it is created automatically by the command. The specified path/directory must exist. If the <code>*.ini</code> file does not exist, it is created. |
| <code>&lt;Key&gt;</code>     | Key for the key/value pair(s).                                                                                                                                                                                                                      |
| <code>&lt;Value&gt;</code>   | String or numeric value for the key/value pair(s). If a string parameter is supplied, it has to be enclosed in single or double quotes.                                                                                                             |

**Example:**

```
PROG:INIP 'c:\preferences\myapp',
'myparameter', 'myvalue', 'startf', 123.05
```

Write two key/value pairs into the file

`c:\preferences\myapp.ini`. The contents of the file look like:

```
[PARAMETER]
myparameter="myvalue"
startf="123.05"
PROG:INIP? 'c:\preferences\myapp',
'myparameter'
```

Query the value of the key `myparameter` in the `*.ini` file. The response is `"myvalue"`.

---

**PROGram[:SElected]:NAME <Program>**

Selects the application to be run on the analyzer. At present, only the general parameter `PROG` is available. This means that `PROGram[:SElected]:EXECute` can start any program.

**Tip:** Use this command in order to avoid problems should the default value change in future firmware versions.

**Parameters:**

|                              |                                                                                                                                              |
|------------------------------|----------------------------------------------------------------------------------------------------------------------------------------------|
| <code>&lt;Program&gt;</code> | <code>PROG</code><br>Any program running under Windows or any file that can be opened with an application program available on the analyzer. |
| <code>*RST:</code>           | <code>PROG</code>                                                                                                                            |

**Example:**

See `PROGram[:SElected]:EXECute`

**PROGram[:SElected]:RETVal?**

Queries the return value of an application or process started via `PROGram[:SElected]:EXECute`.

This will only be successful if preceded by a `PROGram[:SElected]:WAIT?` query (see `PROGram[:SElected]:WAIT` on page 886).

**Example:** See `PROGram[:SElected]:EXECute`

**Usage:** Query only

**PROGram[:SElected]:WAIT**

Locks command execution from the current controller program while a program started via `PROGram[:SElected]:EXECute` is running. The analyzer does not execute any further commands or queries until the program is stopped or paused.

Use `PROGram[:SElected]:WAIT?` before trying to retrieve the return value of the executed program (`PROGram[:SElected]:RETVal?`).

**Example:** See `PROGram[:SElected]:EXECute`

**8.3.14 [SENSe:] Commands**

The `[SENSe:]...` commands affect the receiver settings of the R&S ZND.

**8.3.14.1 [SENSe:]AVERage...**

The `[SENSe:]AVERage...` commands set sweep averaging parameters. The sweep average is a noise-reduction technique which consists of calculating each measurement point as an average of the same measurement point over several consecutive sweeps.



In contrast to the sweep count (for single sweep mode, `[SENSe<Ch>:]SWEep:COUNT`), averaging is always channel-specific. Both features are completely independent from each other.

|                                                      |     |
|------------------------------------------------------|-----|
| <code>[SENSe&lt;Ch&gt;:]AVERage[:STATe]</code> ..... | 886 |
| <code>[SENSe&lt;Ch&gt;:]AVERage:CLEar</code> .....   | 887 |
| <code>[SENSe&lt;Ch&gt;:]AVERage:COUNT</code> .....   | 887 |
| <code>[SENSe&lt;Ch&gt;:]AVERage:MODE</code> .....    | 887 |

**[SENSe<Ch>:]AVERage[:STATe] <Boolean>**

Enable or disable the sweep average.

**Suffix:**

<Ch> Channel number

**Parameters:**

<Boolean> ON | OFF - enables or disables the automatic calculation of the sweep average over the specified number of sweeps ([SENSe<Ch>:]AVERage:COUNT).

\*RST: ON

**Example:** See [SENSe<Ch>:]AVERage:CLEar

**Manual operation:** See "Factor / On / Reset" on page 351

**[SENSe<Ch>:]AVERage:CLEar**

Starts a new average cycle, clearing all previous results and thus eliminating their effect on the new cycle.

**Suffix:**

<Ch> Channel number

**Example:**

```
SENS1:AVER:COUN 15; :AVER ON
Set the average factor for channel 1 to 15 (the mnemonic SENS1
can be omitted) and enable the sweep average.
AVER:COUN 5; CLE
Reduce the average factor and restart the average.
```

**Usage:** Event

**Manual operation:** See "Factor / On / Reset" on page 351

**[SENSe<Ch>:]AVERage:COUNT <AverageFactor>**

Defines the number of consecutive sweeps to be combined for the sweep average ("Factor").

**Suffix:**

<Ch> Channel number

**Parameters:**

<AverageFactor> Sweep average factor

Range: 1 to 1000

\*RST: 10

**Example:** See [SENSe<Ch>:]AVERage:CLEar

**Manual operation:** See "Factor / On / Reset" on page 351

**[SENSe<Ch>:]AVERage:MODE <Mode>****Suffix:**

<Ch>

**Parameters:**

<Mode> AUTO | FLATten | REDuce | MOVing

**AUTO**

Automatic selection between REDuce and FLATten mode, depending on the trace format.

**FLATten**

Cumulative moving averages of the (linear) magnitude and phase values, provides the most effective noise suppression for the "dB Mag", "Phase", "Unwr Phase", and "Lin Mag" formats.

**REDuce**

Cumulative moving averages of the real and imaginary parts of each measurement result, provides the most effective noise suppression for the "Real" and "Imag" formats and for complex trace formats.

**MOVing**

Simple moving averages of the real and imaginary parts of each measurement result; similar to REDuce, but with finite history.

**Manual operation:** See "Mode" on page 351

**8.3.14.2 [SENSe:]BANDwidth...**

The [SENSe:]BANDwidth... commands set the bandwidth of the IF filter (measurement bandwidth). The forms BANDwidth and BWIDth are equivalent.

[SENSe<Ch>:]BANDwidth[:RESolution].....888

[SENSe<Ch>:]BWIDth[:RESolution].....888

---

**[SENSe<Ch>:]BANDwidth[:RESolution] <ResBandw>**

**[SENSe<Ch>:]BWIDth[:RESolution] <IF Bandwidth>**

Defines the IF bandwidth of the analyzer (measurement bandwidth). Values between 1 Hz and 300 kHz can be set.

**Suffix:**

<Ch> Channel number

**Parameters:**

<IF Bandwidth> Bandwidths can be set in 1 – 1.5 – 2 – 3 – 5 – 7 steps. The analyzer rounds up any entered value between these steps and rounds down values exceeding the maximum bandwidth.

Range: See above

\*RST: 10 kHz

Default unit: Hz

**Example:**

BAND 1.1

Set a IF bandwidth of approx. 1.1 Hz for channel 1.

BAND?

The analyzer returns the rounded bandwidth of 1.5 Hz.

**Manual operation:** See "Bandwidth" on page 350

### 8.3.14.3 [SENSe<Ch>:]CDLL...

Adds, removes and configures [custom \(external\) DLLs](#).

These commands allow you to add/remove external DLLs to/from the firmware. It gives access to their configuration, tasks, and traces.

---

#### [SENSe:]CDLL:ADD <DllPath>

Tells the analyzer firmware to load a custom (external) DLL.

The DLL and its accompanying files must be packed in a zip archive. It will be loaded on every subsequent firmware start, until it is removed using [\[SENSe:\]CDLL:REMOve](#).

Note that adding/removing custom DLLs is only possible if the firmware is run as administrator.

#### Setting parameters:

<DllPath> Full path to the zip archive including the DLL (at the top-level).

**Usage:** Setting only

**Manual operation:** See ["Add / Remove"](#) on page 250

---

#### [SENSe:]CDLL:LIST?

Queries the loaded custom (external) DLL files.

The return value is a single string, comprising a comma-separated list of DLL names, without the `dll` extension.

Use [\[SENSe:\]CDLL:ADD/\[SENSe:\]CDLL:REMOve](#) to load/unload a custom DLL..

**Usage:** Query only

**Manual operation:** See ["Loaded DLLs table"](#) on page 249

---

#### [SENSe:]CDLL:REMOve <DllName>

Tells the analyzer firmware to remove a custom (external) DLL that was previously added using [\[SENSe:\]CDLL:ADD](#).

Note that adding/removing custom DLLs is only possible if the firmware is run as administrator.

#### Setting parameters:

<DllName> Name of a loaded DLL (see [\[SENSe:\]CDLL:LIST?](#))  
Lowercase string, without `dll` extension

**Usage:** Setting only

**Manual operation:** See ["Add / Remove"](#) on page 250

---

**[SENSe:]CDLL:LIST:TASK? <DllName>**

Lists the tasks implemented by the custom (external) DLL <DllName>.

**Query parameters:**

<DllName>            Name of a loaded DLL (see [\[SENSe:\]CDLL:LIST?](#))  
Lowercase string, without `dll` extension

**Usage:**            Query only

---

**[SENSe<Ch>:]CDLL:PERManent:ADDITIONal <DllName>, <Additional Input>**

**[SENSe<Ch>:]CDLL:PERManent:ADDITIONal? <DllName>**

Defines additional input for the task to be run, if custom DLL <DllName> is set to permanent mode in channel <Ch> ([\[SENSe<Ch>:\]CDLL:PERManent\[:STATe\]](#) `'<DllName>', ON`).

Use [\[SENSe<Ch>:\]CDLL:PERManent:TASK](#) to select the type of task to be run.

**Suffix:**

<Ch>                    Channel number

**Parameters:**

<Additional Input>    String value, with DLL-specific syntax and semantics. See the docs of your DLL for details.

**Parameters for setting and query:**

<DllName>            Name of a loaded DLL (see [\[SENSe:\]CDLL:LIST?](#))  
Lowercase string, without `dll` extension

**Manual operation:** See ["Additional Input"](#) on page 250

---

**[SENSe<Ch>:]CDLL:PERManent:TASK <DllName>, <Task>**

**[SENSe<Ch>:]CDLL:PERManent:TASK? <DllName>**

Defines the type of task to be run, if custom DLL <DllName> is set to permanent mode in channel <Ch> ([\[SENSe<Ch>:\]CDLL:PERManent\[:STATe\]](#) `'<DllName>', ON`).

Use [\[SENSe<Ch>:\]CDLL:PERManent:ADDITIONal](#) to further specify the task.

**Suffix:**

<Ch>                    Channel number

**Parameters:**

<Task>                 Name of the task to be run permanently.

**Parameters for setting and query:**

<DllName>            Name of a loaded DLL (see [\[SENSe:\]CDLL:LIST?](#))  
Lowercase string, without `dll` extension

**Manual operation:** See ["Task Type"](#) on page 249

---

**[SENSe<Ch>:]CDLL:PERManent[:STATe]** <DllName>, <Boolean>  
**[SENSe<Ch>:]CDLL:PERManent[:STATe]?** <DllName>

Defines whether DLL <DllName> shall operate in permanent mode in channel <Ch>.

Use [\[SENSe<Ch>:\]CDLL:PERManent:TASK](#) and [\[SENSe<Ch>:\]CDLL:PERManent:ADDITIONAL](#) to configure the permanent task to be run.

**Suffix:**

<Ch> Channel number

**Parameters:**

<Boolean> **ON (1)**  
Permanent mode enabled  
**OFF (0)**  
Permanent mode disabled

**Parameters for setting and query:**

<DllName> Name of a loaded DLL (see [\[SENSe:\]CDLL:LIST?](#))  
Lowercase string, without `dll` extension

**Manual operation:** See "[Permanent](#)" on page 249

---

**[SENSe<Ch>:]CDLL:TASK:ADDRess** <DllName>, <Task>, <Address>  
**[SENSe<Ch>:]CDLL:TASK:ADDRess?** <DllName>, <Task>

Defines the address of an external device the external DLL <DllName> requires to complete task type <Task> in channel <Ch>.

**Suffix:**

<Ch> Channel number

**Parameters:**

<Address> String value with DLL-specific syntax and semantics. See the docs of your DLL for details.

**Parameters for setting and query:**

<DllName> Name of a loaded DLL (see [\[SENSe:\]CDLL:LIST?](#))  
Lowercase string, without `dll` extension

<Task> Task type (see [\[SENSe:\]CDLL:LIST:TASK?](#))

**Manual operation:** See "[Configure Device Address](#)" on page 251

---

**[SENSe<Ch>:]CDLL[:STATe]** <DllName>, <Boolean>  
**[SENSe<Ch>:]CDLL[:STATe]?** <DllName>

Defines the state of (external) DLL <DllName>.dll in channel <Ch>.

An active DLL can provide traces or operate in permanent mode (see [\[SENSe<Ch>:\]CDLL:PERManent\[:STATe\]](#)).

**Suffix:**

<Ch> Channel number

**Parameters:**

<Boolean> **ON (1)**  
DLL is active

**OFF (0)**  
DLL is inactive

**Parameters for setting and query:**

<DllName> Name of a loaded DLL (see [\[SENSe:\]CDLL:LIST?](#))  
Lowercase string, without dll extension

**Manual operation:** See ["Active"](#) on page 249

**8.3.14.4 [SENSe:]CORRection:CDATa...**

The [\[SENSe:\]CORRection:CDATa...](#) commands read or write system error correction data.

---

**[SENSe<Ch>:]CORRection:CDATa** <ErrorTerm>, <SourcePort>, <LoadPort>, <CorrectionData>...

Writes or reads system error correction data for a specific channel <Ch>, calibration method ([\[SENSe<Ch>:\]CORRection:COLLect:MEthod:DEFine](#)), and port combination <SourcePort>, <LoadPort>. The setting command can be used to transfer user-defined correction data <CorrectionData> to the analyzer; the query returns the current correction data set. ASCII or block data can be transferred, depending on the selected data transfer format ([FORMat\[:DATA\]](#)).

The sweep must be stopped to transfer calibration data; see program example for [\[SENSe<Ch>:\]CORRection:COLLect:SAVE:SElected:DEFault](#).

**Note:** This command affects the active calibration of channel no. <Ch> or the factory calibration (if no channel calibration is active). For the factory calibration, the query form is allowed only (no change of factory calibration data).

**Tip:** The analyzer provides a default calibration corresponding to a test setup which does not introduce any systematic errors; see [\[SENSe<Ch>:\]CORRection:COLLect:SAVE:SElected:DEFault](#).

For an overview of calibration methods and error terms refer to [Chapter 5.5.1, "Calibration Types"](#), on page 141.

**G and H matrices**

The 7-term calibration types named Txx (e.g. TOM, TRM, TRL, TNA) are based on a network analyzer with two ports i and j, each equipped with a test receiver and a reference receiver. The system errors are described in terms of two "error two-ports"  $P_G$  and  $P_H$ :

- The error two-port  $P_G$  is assigned to port i of the analyzer. Its transmission matrix G describes how the system errors modify the outgoing and incident waves at port i:



$$\begin{bmatrix} \mathbf{b}_i \\ \mathbf{a}_i \end{bmatrix} = \begin{bmatrix} \mathbf{G}_{11} & \mathbf{G}_{12} \\ \mathbf{G}_{21} & \mathbf{G}_{22} \end{bmatrix} * \begin{bmatrix} \mathbf{m}_{i\text{ref}} \\ \mathbf{m}_{i\text{test}} \end{bmatrix}$$

- The error two-port  $P_H$  is assigned to port  $j$  of the analyzer. Its transmission matrix  $H$  describes how the system errors modify the measured incident and outgoing waves at port  $j$ :

$$\begin{bmatrix} \mathbf{a}_j \\ \mathbf{b}_j \end{bmatrix} = \begin{bmatrix} \mathbf{H}_{11} & \mathbf{H}_{12} \\ \mathbf{H}_{21} & \mathbf{H}_{22} \end{bmatrix} * \begin{bmatrix} \mathbf{m}_{j\text{test}} \\ \mathbf{m}_{j\text{ref}} \end{bmatrix}$$

In the two equations above,  $a$  and  $b$  denote the waves at the calibrated reference plane  $i$  and  $j$  (e.g. the input and output of the 2-port DUT). The  $m$  waves are the raw measured waves of test port  $i$  and  $j$ . The subscripts "ref" and "test" refer to the reference and test receivers, respectively. During the calibration the network analyzer acquires ratios of wave quantities, which leaves one of non-diagonal matrix elements of  $G$  or  $H$  as a free normalization factor. The network analyzer uses the normalization  $H_{21} = 1$ .

**Suffix:**

<Ch> Channel number of the calibrated channel.

**Parameters:**

<ErrorTerm>

String parameters describing the different error terms, depending on the current calibration method; see table below. Each term contains one complex value (real and imaginary part) for each sweep point. The parameters must be transferred in full length. The following strings are allowed:

**'DIRECTIVITY'**

Directivity at source port <SourcePort>

**'SRCMATCH'**

Source match at source port <SourcePort>

**'REFLTRACK'**

Reflection tracking at source port <SourcePort>

**'LOADMATCH'**

Load match at load port <LoadPort>

**'TRANSTRACK'**

Transmission tracking between source port <SourcePort> and load port <LoadPort>.

**'G11' ... 'G22'**

G matrix elements at source port <SourcePort>; see explanation above.

**'H11' ... 'H22'**

H matrix elements at load port <LoadPort>; see explanation above.

Range: The error terms are dimensionless complex numbers.

\*RST: n/a

<SourcePort> Source port number

- <LoadPort> Load port number. If the error term is not related to the load port, a dummy number can be used; e.g. `CORR:CDAT 'REFLTRACK', 1, 0`
- <CorrectionData> Correction data set (one complex number per sweep point) to be transferred to the analyzer either in ASCII or block data format, depending on the current `FORMat[:DATA]` setting. The correction data set is assigned to the specified channel, error term, source and load port.  
This parameter must not be used for queries.

**Example:** See `[SENSe<Ch>:]CORRection:COLLect:SAVE:SELected:DEFault`.

The different calibration types of the analyzer provide the following error terms:

| Calibration type                                                      | Parameters in<br><code>[SENSe&lt;Ch&gt;:]CORRection:COLLect:METHOD:DEFine</code> | Available error terms (depending on port numbers)                                                                                                                                                            |
|-----------------------------------------------------------------------|----------------------------------------------------------------------------------|--------------------------------------------------------------------------------------------------------------------------------------------------------------------------------------------------------------|
| One-port normalization (reflection) using an open or a short standard | REFL, RSHort                                                                     | 'REFLTRACK'                                                                                                                                                                                                  |
| Full one port ("Refl OSM")                                            | FOPort                                                                           | 'DIRECTIVITY', 'SRCMATCH', 'REFLTRACK'                                                                                                                                                                       |
| Two-port normalization                                                | FRTRans                                                                          | 'TRANSTRACK'                                                                                                                                                                                                 |
| One path two port                                                     | OPTPort                                                                          | 'DIRECTIVITY', 'SRCMATCH', 'REFLTRACK', 'TRANSTRACK'                                                                                                                                                         |
| TOSM                                                                  | TOSM                                                                             | 'DIRECTIVITY', 'SRCMATCH', 'REFLTRACK', 'LOADMATCH', 'TRANSTRACK'                                                                                                                                            |
| TOM, TSM, TRM, TRL, TNA                                               | TOM   TSM   TRM   TRL   TNA                                                      | 'DIRECTIVITY', 'SRCMATCH', 'REFLTRACK', 'LOADMATCH', 'TRANSTRACK' (for reading and writing)<br><br>'G11' ... 'G22' and 'H11', 'H12', 'H22' (for reading only; the 'H21' matrix elements are normalized to 1) |

#### 8.3.14.5 `[SENSe:]CORRection:SMATrix:CDATa...`

The `[SENSe:]CORRection:SMATrix:CDATa...` commands read or write system error correction data in the presence of switching matrices (see [Chapter 5.7.20, "External Switch Matrices"](#), on page 210).

---

`[SENSe<Ch>:]CORRection:SMATrix:CDATa <ErrorTerm>, <SourceTestPort>, <LoadTestPort>, <SourceVNAPort>, <LoadVNAPort>, <CorrectionData>...`

`[SENSe<Ch>:]CORRection:SMATrix:CDATa:PORT<PhyPt> <ErrorTerm>, <SourceTestPort>, <LoadTestPort>, <SourceVNAPort>, <LoadVNAPort>, <CorrectionData>...`

Writes or reads system error correction data in the presence of switching matrices.

Same command structure and logic as for [\[SENSe:\]CORRection:CDATa...](#) commands, except for additional parameters `SourceVNAPort` and `LoadVNAPort` that restrict the returned correction data to the measurement path between by the respective physical VNA ports (if any). See [Chapter 5.7.20.5, "Multiple Paths and Calibration"](#), on page 215 for details.

**Suffix:**

&lt;Ch&gt;

&lt;PhyPt&gt;

**Parameters:**

&lt;ErrorTerm&gt;

&lt;SourceTestPort&gt;

&lt;LoadTestPort&gt;

<SourceVNAPort> Number of the VNA port connected to the source test port (via switch matrix)

<LoadVNAPort> Number of the VNA port connected to the load test port (via switch matrix)

<CorrectionData> Correction data either in ASCII or block data format, depending on the current [FORMat \[:DATA\]](#) setting.

**8.3.14.6 [SENSe:]CORRection:CKIT...**

The [\[SENSe:\]CORRection:CKIT...](#) commands deal with calibration kits and cal kit data. The calibration kits are distinguished by their names (<CalkitName>), the optional labels (<label>) can be used to carry information about the calibration standard.

In order to handle several identical calibration kits with different serial numbers use the commands of [Chapter 8.3.14.7, "\[SENSe:\]CORRection:CKIT... with Labels"](#), on page 903.

|                                                                       |     |
|-----------------------------------------------------------------------|-----|
| <a href="#">[SENSe:]CORRection:CKIT:CATalog?</a> .....                | 895 |
| <a href="#">[SENSe:]CORRection:CKIT:DELeTe</a> .....                  | 896 |
| <a href="#">[SENSe:]CORRection:CKIT:DMODE</a> .....                   | 896 |
| <a href="#">[SENSe:]CORRection:CKIT:LABel</a> .....                   | 897 |
| <a href="#">[SENSe:]CORRection:CKIT:SELeCt</a> .....                  | 897 |
| <a href="#">[SENSe:]CORRection:CKIT:STANdard:CATalog?</a> .....       | 898 |
| <a href="#">[SENSe:]CORRection:CKIT:STANdard:DATA?</a> .....          | 898 |
| <a href="#">[SENSe:]CORRection:CKIT:&lt;ConnType&gt;:SELeCt</a> ..... | 899 |
| <a href="#">[SENSe:]CORRection:CKIT:&lt;StandardType&gt;</a> .....    | 900 |

**[SENSe:]CORRection:CKIT:CATalog? [<ConnectorType>]**

Returns a list of all cal kits for a given connector type or for all connector types.

**Query parameters:**

<ConnectorType> Name of the connector type (optional). Use `[SENSe<Ch>:]CORRection:CONNection:CATalog?` to query connector names.  
If omitted, the command returns the list of all cal kits.

**Example:** See `[SENSe<Ch>:]CORRection:CONNection:CATalog?`

**Usage:** Query only

**Manual operation:** See "[Available Cal Kits](#)" on page 405

**[SENSe:]CORRection:CKIT:DELeTe <CalKitName>**

Deletes an imported or user-defined cal kit.

**Note:** It is not possible to modify or store predefined or ideal kits.

**Setting parameters:**

<CalKitName> String parameter containing an imported or user-defined calibration kit available on the analyzer.

**Example:** See `[SENSe:]CORRection:CKIT:LAbel`

**Usage:** Setting only

**Manual operation:** See "[Add / Copy / Delete / Standards...](#)" on page 405

**[SENSe:]CORRection:CKIT:DMODE <ConnectorType>, <CalKitName>, <KitLabel>, <Mode>**

Sets/gets the delay mode for the related cal kit (identified by connector type, name and label), i.e allows to toggle between ZVR compatible and Keysight modelling (see "[Offset Parameters](#)" on page 408). Subsequent standard definitions interpret the specified <DelayParam> accordingly.

In "set direction", if a cal kit with the given connector type, name and label is not available on the analyzer, it is created automatically.

Cal kits that are not created/modified using `[SENSe:]CORRection:CKIT:DMODE` use the ZVR compatible modelling.

**Parameters:**

<ConnectorType> Name of the connector type. Use `[SENSe<Ch>:]CORRection:CONNection:CATalog?` to query connector names.

<CalKitName> String parameter containing the name of the calibration kit. See "Cal kit naming conventions " under `[SENSe:]CORRection:CKIT:<ConnType>:LSElect`.

<KitLabel> String parameter containing the label of the calibration kit, usually the serial number.

**Setting parameters:**

<Mode> DELay | ELENgth  
 DELay – Keysight modelling  
 ELENgth – ZVR compatible modelling

**Manual operation:** See "Add / Copy / Delete / Standards..." on page 405

**[SENSe:]CORRection:CKIT:LABel** <CalKitName>[, <KitLabel>]

Assigns a label to an imported or user-defined calibration kit.

**Parameters:**

<CalKitName> String parameter containing an imported or user-defined calibration kit available on the analyzer.

<KitLabel> String parameter containing the calibration kit label.

**Example:**

```
CORR:CKIT:FOP 'N 50 Ohm', 'New Kit 1', '',
0,4000000000,0,0,50,99,-2.3,0.22,0,0,0,0,0
```

Create a new cal kit "New Kit 1" and assign an open (f) standard for the N 50 Ω connector type with specific properties.

```
CORR:CKIT:LAB 'New Kit 1', 'Test kit created
today'
```

Label the previously created kit.

```
CORR:CKIT:LAB? 'New Kit 1'
```

Check the label.

```
CORR:CKIT:DEL 'New Kit 1'
```

Delete the kit.

**[SENSe:]CORRection:CKIT:SElect** <ConnectorType>[, <CalKitName>]

Selects the calibration kit to be used, specifying its connector type and name (optional).

**Tip:** The command is suitable for connector types with arbitrary, user-defined names. For standard connector types you can use the command `[SENSe:]CORRection:CKIT:<ConnType>:SElect`.

**Parameters:**

<ConnectorType> Connector type, e.g. a user-defined connector type (string variable).

<CalKitName> String parameter containing the name of a calibration kit available on the analyzer.

**Example:**

```
MMEM:LOAD:CKIT 'C:\Users\Public\
Documents\Rohde-Schwarz\Vna\
Calibration\Kits\New Kit 1.calkit'
Load the previously created cal kit file New Kit 1.calkit
from the default cal kit directory.
CORR:CKIT:SEL 'N 50 Ohm', 'New Kit 1'
Assign the imported kit to the N 50 Ω connector type, assuming
that the cal kit name stored in New Kit 1.calkit reads New
Kit 1.
```

**Manual operation:** See ["Cal Kit"](#) on page 389

**[SENSe:]CORRection:CKIT:STANdard:CATalog? <CalKitName>**

Returns a list of all standards in a given calibration kit.

**Query parameters:**

<CalKitName> Name of the cal kit. Use [\[SENSe:\]CORRection:CKIT:CATalog?](#) to query cal kit names.

**Example:** See [\[SENSe<Ch>:\]CORRection:CONNection:CATalog?](#)

**Usage:** Query only

**[SENSe:]CORRection:CKIT:STANdard:DATA? <ConnectorType>, <CalKitName>, <KitLabel>, <StandardType>, <DelayMode>[, <Port1>[, <Port2>]]**

Returns the data of the related calibration standard (identified by <ConnectorType>, <CalKitName>, <KitLabel> and <StandardType>) and - optionally - restricted to the given port(s).

The delay parameter is returned according to the selected <DelayMode>; see [Table 8-12](#).

**Query parameters:**

<ConnectorType> Name of the connector type. Use [\[SENSe<Ch>:\]CORRection:CONNection:CATalog?](#) to query connector names.

<CalKitName> String parameter containing the name of the calibration kit. See "Cal kit naming conventions" under [\[SENSe:\]CORRection:CKIT:<ConnType>:LSElect](#).

<KitLabel> String parameter containing the label of the calibration kit, usually the serial number.

|                    |                                                                                                                                                                                                                                                                                                                                                                                                                                                                  |
|--------------------|------------------------------------------------------------------------------------------------------------------------------------------------------------------------------------------------------------------------------------------------------------------------------------------------------------------------------------------------------------------------------------------------------------------------------------------------------------------|
| <StandardType>     | MMTHrough   MFTThrough   FFTThrough   MMLine   MMLine1   MMLine2   MMLine3   MFLine   MFLine1   MFLine2   MFLine3   FFLine   FFLine1   FFLine2   FFLine3   MMATten   MFATten   FFATten   MMSNetwork   MFSNetwork   FFSNetwork   MOPen   FOPen   MSHort   FSHort   MOShort   MOShort1   MOShort2   MOShort3   FOSHort   FOSHort1   FOSHort2   FOSHort3   MREFlect   FREFlect   MMTCh   FMTCh   MSMATCH   FSMATCH<br>Standard type; see <a href="#">Table 8-13</a> |
| <DelayMode>        | DELay   ELENgth<br>ELENgth (default) – ZVR compatible modelling<br>DELay – Keysight modelling                                                                                                                                                                                                                                                                                                                                                                    |
| <Port1>[, <Port2>] | Optional port restriction: one port number for one port standards, two port numbers for two port standards                                                                                                                                                                                                                                                                                                                                                       |
| <b>Usage:</b>      | Query only                                                                                                                                                                                                                                                                                                                                                                                                                                                       |

---

### [SENSe:]CORRection:CKIT:<ConnType>:SElect <CalKitName>

Selects the calibration kit to be used for a specified connector type <ConnType>. The kit is identified by its name.

**Tip:** For connector types with arbitrary, user-defined names you can use the command [\[SENSe:\]CORRection:CKIT:SElect](#).

#### Cal kit naming conventions

Calibration kit names must be entered as string parameters. The string contains the cal kit name used in the calibration dialogs (e.g. "Calibration Presettings"); a "Ω" in the name must be replaced by Ohm, e.g.:

- `NewKit1` denotes the user-defined calibration kit "NewKit1".
- `N 50 Ohm Ideal Kit` denotes the "N 50 Ω Ideal Kit".
- `ZV-Z21 typical` denotes the cal kit "ZV-Z21 typical".

#### Suffix:

|            |                                                                                                                                                                                                                                                              |
|------------|--------------------------------------------------------------------------------------------------------------------------------------------------------------------------------------------------------------------------------------------------------------|
| <ConnType> | Connector type, one of the following identifiers:<br>N50, N75 – N 50 Ω or N 75 Ω connectors<br>PC7, PC35, PC292 – PC 7, PC 3.5 or 2.92 mm connectors<br>USER<no> – user-defined connectors UserConn1, UserConn2<br>SMA – user-defined connector type SMA ... |
|------------|--------------------------------------------------------------------------------------------------------------------------------------------------------------------------------------------------------------------------------------------------------------|

#### Parameters:

|              |                                                                                                                              |
|--------------|------------------------------------------------------------------------------------------------------------------------------|
| <CalKitName> | String parameter containing the name of a calibration kit available on the analyzer. See "Cal kit naming conventions" above. |
| *RST:        | n/a (A *RST does not change the assignment between connector types and calibration kits.)                                    |

**Example:**

```
MMEM:LOAD:CKIT 'C:\Users\Public\
Documents\Rohde-Schwarz\Vna\
Calibration\Kits\New Kit 1.calkit'
Load the previously created cal kit file New Kit 1.calkit
from the default cal kit directory.
CORR:CKIT:N50:SEL 'New Kit 1'
Assign the imported kit to the N 50 Ω connector type, assuming
that the cal kit name stored in New Kit 1.calkit reads New
Kit 1.
```

**Manual operation:** See ["Add / Copy / Delete / Standards..."](#) on page 405

---

```
[SENSe:]CORRection:CKIT:<StandardType> <ConnType>, <CalKitName>,
<StandardLabel>, <MinFreq>, <MaxFreq>[, <DelayParam>, <Loss>, <Z0>[,
<C0>, <C1>, <C2>, <C3>, <L0>, <L1>, <L2>, <L3>[, OPEN | SHORT | MATCH |
<Resistance>[, <Port1>[, <Port2>]]]]]
```

```
[SENSe:]CORRection:CKIT:<StandardType>? <ConnType>, <CalKitName>[,
<Port1>[, <Port2>]]
```

Defines the parameters of a (possibly non-ideal) 1 port or 2-port calibration standard `<StandardType>` within a particular cal kit. Depending on the standard type, only a subset of the parameters is used; see [Table 8-11](#)

#### Note

As the query does not reflect the delay mode specified using `[SENSe:]CORRection:CKIT:DMODE`, it is deprecated and only available for backward compatibility reasons. Use `[SENSe:]CORRection:CKIT:STANdard:DATA??` instead.

#### Suffix:

`<StandardType>`      `<string>`  
Standard type  
For one-port standards, the first character denotes the gender, for transmission standards the first two characters denote the genders on both ends, e.g. `MOPen` for a male Open standard or `FFThrougH` for a Through standard with female connectors. For a complete list of standards, refer to [Table 8-13](#).

#### Parameters:

`<StandardLabel>`      Additional string label for the standard, typically the standard's serial number

`CalStandardProps`      Parameters `<MinFreq>`, ..., `OPEN | SHORT | MATCH | <Resistance>` define the properties of the calibration standard. See [Parameter list](#).

**Note:** Sliding Match and Attenuation standards have only 2 parameters (`<MinFreq>`, `<MaxFreq>`). Through and Line standards only have 5 parameters (`<MinFreq>`, ..., `<Z0>`).



<Port1>, <Port2> Optional port restriction.  
 For a one-port standard, the validity of the characterization can be restricted to a single port. For a two-port standard, it can be restricted to a port pair (specified using ascending port numbers).  
**Note:** with a port restriction, the defined standard becomes sex-less. Hence, for each port (pair) there can be only one standard of a given type, i.e. :SENSe:CORRection:CKIT:MOP <ParameterList>,1 and :SENSe:CORRection:CKIT:FOP <ParameterList>,1 overwrite each other.

**Parameters for setting and query:**

<ConnType>, <CalkitName> String parameters uniquely identifying the cal kit to which the standard belongs.  
**Note:** If the specified cal kit does not exist, it is created with the specified calibration standard.

**Example:**

```
CORR:CKIT:FOP 'N 50 Ohm','New Kit 1',' ',
0,4000000000,0,0,50,99,-2.3,0.22,0,0,0,0,0
Define the properties of the Open (f) standard for a N 50 Ω connector type in cal kit "New Kit 1".
CORR:CKIT:FOP? 'N 50 Ohm'
Query the properties of the Open (f) standard for a N 50 Ω connector type in the active cal kit.
CORR:CKIT:FOP? 'N 50 Ohm','New Kit 1'
Query the properties of the Open (f) standard for a N 50 Ω connector type in cal kit "New Kit 1".
```

**Manual operation:** See ["One Port Standards / Two Port Standards"](#) on page 406

Table 8-11: Set command parameters

|                            | One port standards                          |                |            |             |               | Two port standards |               |             |
|----------------------------|---------------------------------------------|----------------|------------|-------------|---------------|--------------------|---------------|-------------|
|                            | Open                                        | (Offset) Short | Match      | Reflect     | Sliding match | Symmetric network  | Through, Line | Attenuation |
| <ConnType>                 | mandatory                                   |                |            |             |               |                    |               |             |
| <CalkitName>               | mandatory (and must not be an empty string) |                |            |             |               |                    |               |             |
| <StandardLabel>            | mandatory (but can be an empty string)      |                |            |             |               |                    |               |             |
| <MinFreq>, <MaxFreq>       | mandatory                                   |                |            |             |               |                    |               |             |
| <DelayParam>, <Loss>, <Z0> | mandatory                                   | mandatory      | mandatory  | mandatory   | not used      | mandatory          |               | not used    |
| <C0>, <C1>, <C2>, <C3>     | mandatory                                   | mandatory*     | mandatory* | mandatory** |               | mandatory**        | not used      |             |

|                                                                                                                                                                                                                                                                                                                                               |                    |             |             |                                            |  |                                            |  |  |
|-----------------------------------------------------------------------------------------------------------------------------------------------------------------------------------------------------------------------------------------------------------------------------------------------------------------------------------------------|--------------------|-------------|-------------|--------------------------------------------|--|--------------------------------------------|--|--|
| <L0>, <L1>, <L2>, <L3>                                                                                                                                                                                                                                                                                                                        | mandatory*         | mandatory   | mandatory*  | mandatory**                                |  | mandatory**                                |  |  |
| OPEN   SHORt   MATCh   <Resist-ance>                                                                                                                                                                                                                                                                                                          | optional***        | optional*** | optional*** | mandatory:<br>OPEN   SHORt   <Resist-ance> |  | mandatory:<br>OPEN   SHORt   <Resist-ance> |  |  |
| <Port1>[, <Port2>]                                                                                                                                                                                                                                                                                                                            | optional: <Port 1> |             |             |                                            |  | optional: <Port 1>,<Port 2>                |  |  |
| <p>* values are ignored during calibration</p> <p>** if OPEN is selected the residual inductance (L0,...,L3) are during calibration; if SHORt is selected the fringing capacitance (C0,...,C3) are during calibration</p> <p>*** must be provided if the definition is restricted to a single port. Values are ignored during calibration</p> |                    |             |             |                                            |  |                                            |  |  |

The parameters in the `[SENSe<Ch>:]CORRection:CKIT:<StandardType>`, `[SENSe<Ch>:]CORRection:CKIT:<StandardType>:WLAbelS`, and `[SENSe<Ch>:]CORRection:CKIT:<ConnectorType>:<StandardType>` commands have the following meaning:

**Table 8-12: Parameter list**

| Parameter            | Meaning                                                                                                                                                                                                                                                                                                                                                                                              | Comment/Unit                                                                                     |
|----------------------|------------------------------------------------------------------------------------------------------------------------------------------------------------------------------------------------------------------------------------------------------------------------------------------------------------------------------------------------------------------------------------------------------|--------------------------------------------------------------------------------------------------|
| '<ConnType>'         | Name of the connector type.<br>Use <code>SENSe1:CORRection:CONNection:CATalog?</code> to query connector names.                                                                                                                                                                                                                                                                                      | String parameter                                                                                 |
| '<CalKitName>'       | Name of the calibration kit. Use <code>[SENSe:]CORRection:CKIT:CATalog?</code> to query cal kit names.                                                                                                                                                                                                                                                                                               | String parameter                                                                                 |
| '<CalKitLabel>'      | Label (e.g. the serial number) of the calibration kit; for <code>WLAbel</code> command only                                                                                                                                                                                                                                                                                                          | String parameter                                                                                 |
| '<StandardLabel>'    | Label (e.g. the serial number) of the standard                                                                                                                                                                                                                                                                                                                                                       | String parameter                                                                                 |
| <MinFreq>, <MaxFreq> | Min./max. frequency for which the circuit model is valid                                                                                                                                                                                                                                                                                                                                             | Default unit is Hz                                                                               |
| <DelayParam>         | Depending on the cal kit's model type (selected using <code>[SENSe:]CORRection:CKIT:DMoDe</code> ), this parameter is interpreted as: <ul style="list-style-type: none"> <li>delay [s] for Keysight modeling</li> <li>el. length [m] for ZVR compatible modeling</li> </ul> Cal kits that are not created/modified using <code>[SENSe:]CORRection:CKIT:DMoDe</code> use the ZVR compatible modeling. |                                                                                                  |
| <Loss>               | Loss (offset parameter) of the standard                                                                                                                                                                                                                                                                                                                                                              | Must be specified without unit (implicit unit is dB)                                             |
| <Z0>                 | Reference impedance (no unit)                                                                                                                                                                                                                                                                                                                                                                        | Must be specified without unit (implicit unit is $\Omega$ )                                      |
| <C0>,...,<C3>        | Polynomial coefficients for the fringing capacitance of the standard (load parameter)                                                                                                                                                                                                                                                                                                                | Must be specified without unit: implicit unit of <C <i>i</i> > is fF / (GHz) <sup><i>i</i></sup> |
| <L0>,...,<L3>        | Polynomial coefficients for the residual inductance of the standard (load parameter)                                                                                                                                                                                                                                                                                                                 | Must be specified without unit: implicit unit of <L <i>i</i> > is pH / (GHz) <sup><i>i</i></sup> |

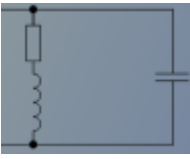
| Parameter                           | Meaning                                                                                                                                                                                                                                                                                                                                                                                                                                                                                                                                                                                                                                                                                                                                                                      | Comment/Unit                                                                                                              |
|-------------------------------------|------------------------------------------------------------------------------------------------------------------------------------------------------------------------------------------------------------------------------------------------------------------------------------------------------------------------------------------------------------------------------------------------------------------------------------------------------------------------------------------------------------------------------------------------------------------------------------------------------------------------------------------------------------------------------------------------------------------------------------------------------------------------------|---------------------------------------------------------------------------------------------------------------------------|
| OPEN   SHORt   MATCh   <Resistance> | <p>A load circuit model generally consists of a capacitance (modeled by &lt;C0&gt;, ..., &lt;C3&gt;), connected in parallel to an inductance (modeled by &lt;L0&gt;, ..., &lt;L3&gt;) and a resistance, both connected in series.</p> <p>OPEN   SHORt   MATCh indicates a simplified modeling as an Open or Short or Match standard.</p> <ul style="list-style-type: none"> <li>• OPEN: the resistance is infinite so that the standard behaves like a capacitor (no inductance)</li> <li>• SHORt: the resistance is zero so that the standard behaves like an inductance (no capacitance)</li> <li>• MATCh: the standard behaves like a match (no inductance, no capacitance, resistance Z0)</li> </ul> <p>&lt;Resistance&gt; indicates the general load circuit model.</p> |  <p>Character data   numeric value</p> |
| <Port1>, <Port2>                    | Optional port restriction: one port number for one-port standards, two port numbers for two-port standards                                                                                                                                                                                                                                                                                                                                                                                                                                                                                                                                                                                                                                                                   | Integer values                                                                                                            |

The different standard types are defined by the following parameters. Port restrictions are indicated in brackets:

**Table 8-13: Standard types and their parameters**

| <std_type>                                                                       | Meaning                                                                                                                    |
|----------------------------------------------------------------------------------|----------------------------------------------------------------------------------------------------------------------------|
| MOPen   FOPen                                                                    | Open: male (m) or female (f)                                                                                               |
| MSHort   FSHort                                                                  | Short: m or f                                                                                                              |
| OSHort[<1 2 3>]   MOSHort[<1 2 3>]   FOSHort[<1 2 3>]                            | Offset short: sexless, m or f (three standards each)<br>For user-defined connector types only.<br>Suffix 1 can be omitted. |
| MMTCh   FMTCh                                                                    | Match: m or f                                                                                                              |
| MSMatch   FSMatch                                                                | Sliding match: m or f                                                                                                      |
| MREFlect   FREFlect                                                              | Reflect: m or f                                                                                                            |
| MMTHrough   MFTHrough   FFTHrough                                                | Through: m-m or m-f or f-f                                                                                                 |
| MMLine[<1 2 3>]   MFLine[<1 2 3>]   FFLine[<1 2 3>]<br>MMLine[<1 2 3>](P2P3) ... | Line: m-m or m-f or f-f (three standards each)<br>Suffix 1 can be omitted.                                                 |
| MMATten   MFATten   FFATten                                                      | Attenuation: m-m or m-f or f-f                                                                                             |
| MMSNetwork   MFSNetwork   FFSNetwork                                             | Symmetric network: m-m or m-f or f-f                                                                                       |

### 8.3.14.7 [SENSe:]CORRection:CKIT... with Labels

The following [SENSe:]CORRection:CKIT... commands identify the calibration kit to be used by a combination of its <CalkitName> and <CalkitLabel>. Typically, the serial number of the calibration kit serves as a calibration kit label. Due to their different labels, the analyzer can handle several calibration kits with identical names.

|                                                             |     |
|-------------------------------------------------------------|-----|
| [SENSe:]CORRection:CKIT:LCATalog?                           | 904 |
| [SENSe:]CORRection:CKIT:LDELeTe                             | 904 |
| [SENSe:]CORRection:CKIT:LLABel                              | 904 |
| [SENSe:]CORRection:CKIT:LSELeCt                             | 905 |
| [SENSe:]CORRection:CKIT:STANdard:LCATalog?                  | 906 |
| [SENSe:]CORRection:CKIT:<ConnType>:LSELeCt                  | 906 |
| [SENSe:]CORRection:CKIT:<StandardType>:WLABel               | 907 |
| [SENSe:]CORRection:CKIT:<OnePortStandardType>:WLABel:SDATa? | 907 |
| [SENSe:]CORRection:CKIT:<TwoPortStandard>:WLABel:SDATa?     | 908 |

---

### [SENSe:]CORRection:CKIT:LCATalog? [<ConnectorType>]

Returns a list of all cal kits and their labels for a given connector type or for all connector types.

#### Query parameters:

<ConnectorType> Name of the connector type. Use [SENSe<Ch>:]CORRection:CONNection:CATalog? to query connector names.  
If omitted, the command returns the list of all cal kits and labels.

**Example:** See [SENSe<Ch>:]CORRection:CONNection:CATalog?

**Usage:** Query only

---

### [SENSe:]CORRection:CKIT:LDELeTe <CalKitName>, <KitLabel>

Deletes an imported or user-defined cal kit which is identified by its cal kit name and label.

**Note:** It is not possible to modify or store predefined or ideal kits.

#### Setting parameters:

<CalKitName> String parameter containing an imported or user-defined calibration kit available on the analyzer.

<KitLabel> String parameter containing the label of an imported or user-defined calibration kit available on the analyzer.

**Example:** See [SENSe:]CORRection:CKIT:LLABel

**Usage:** Setting only

---

### [SENSe:]CORRection:CKIT:LLABel <CalKitName>, <KitLabel>[, <NewKitLabel>]

Assigns a calibration kit label to an imported or user-defined calibration kit or renames an existing calibration kit label.

#### Parameters:

<CalKitName> String parameter containing an imported or user-defined calibration kit available on the analyzer.

<KitLabel> String parameter containing the current calibration kit label.

<NewKitLabel> String parameter containing the new calibration kit label.

**Example:**

```
CORR:CKIT:FOP:WLAB 'N 50 Ohm', 'New Kit 1',
'Test kit created today', '',
0,4000000000,0,0,50,99,-2.3,0.22,0,0,0,0,0
```

Create a new cal kit "New Kit 1" labelled "Test kit created today" and assign an open (f) standard for the N 50 Ω connector type with specific properties.

```
CORR:CKIT:LLAB 'New Kit 1', 'Test kit created
today', '2012-05-25'
```

Change the label of the previously created kit.

```
CORR:CKIT:LLAB? 'New Kit 1', '2012-05-25'
```

Check the label.

```
MMEemory:STORe:CKIT:
WLABel 'New Kit 1', '2012-05-25', 'C:
\Users\Public\Documents
\Rohde-Schwarz\Vna\Calibration\Kits\New Kit 1
(2012-05-25).calkit'
```

Store the data for the labelled cal kit to the cal kit file

```
New Kit 1 (2012-05-25).calkit.
```

```
CORR:CKIT:LDEL 'New Kit 1', '2012-05-25'
```

Delete the kit. from the internal memory.

```
MMEemory:LOAD:CKIT 'C:\Users\Public\Documents
\Rohde-Schwarz\Vna\Calibration\Kits\New Kit 1
(2012-05-25).calkit'
```

Re-load the kit.

---

**[SENSe:]CORRection:CKIT:LSElect** <ConnectorType>, <CalKitName>, <KitLabel>

Selects the calibration kit to be used, specifying its connector type, name, and label.

**Tip:** The command is suitable for connector types with arbitrary, user-defined names. For standard connector types you can use the command `[SENSe:]CORRection:CKIT:<ConnType>:LSElect`.

**Parameters:**

<ConnectorType> Connector type, e.g. a user-defined connector type (string variable).

<CalKitName> String parameter containing the name of a calibration kit available on the analyzer.

<KitLabel> String parameter containing the label of a calibration kit available on the analyzer.

**Example:**

```
MMEM:LOAD:CKIT 'C:\Users\Public\
Documents\Rohde-Schwarz\Vna\
Calibration\Kits\New Kit 1 (123456).calkit'
Load the previously created cal kit file
New Kit 1 (123456).calkit from the default cal kit direc-
tory.
CORR:CKIT:LSEL 'N 50 Ohm', 'New Kit 1',
'123456'
Assign the imported kit to the N 50 Ω connector type, assuming
that the cal kit name stored in New Kit 1 (123456).calkit
reads New Kit 1 and that its label reads 123456.
```

---

**[SENSe:]CORRection:CKIT:STANdard:LCATalog? <CalKitName>, <KitLabel>**

Returns a list of all standards in a given calibration kit.

**Query parameters:**

<CalKitName> Name of the cal kit. Use [\[SENSe:\]CORRection:CKIT:LCATalog?](#) to query cal kit names and labels.

<KitLabel> Label of the cal kit.

**Example:** See [\[SENSe<Ch>:\]CORRection:CONNECTION:CATalog?](#)

**Usage:** Query only

---

**[SENSe:]CORRection:CKIT:<ConnType>:LSElect <CalKitName>, <Label>**

Selects the calibration kit to be used for a specified connector type <ConnType>. The kit is identified by its name and label.

**Tip:** For connector types with arbitrary, user-defined names and labels you can use the command [\[SENSe:\]CORRection:CKIT:LSElect](#).

**Suffix:**

<ConnType> Connector type, one of the following identifiers:  
 N50, N75 – N 50 Ω or N 75 Ω connectors  
 PC7, PC35, PC292 – PC 7, PC 3.5 or 2.92 mm connectors  
 USER<no> – user-defined connectors UserConn1, UserConn2  
 SMA – user-defined connector type SMA ...

**Parameters:**

<CalKitName> String parameter containing the name of a calibration kit available on the analyzer. See "Cal kit naming conventions " under [\[SENSe:\]CORRection:CKIT:<ConnType>:LSElect](#).

\*RST: n/a (A \*RST does not change the assignment between connector types and calibration kits.)

<CalKitLabel> String parameter containing the label of a calibration kit available on the analyzer, usually the serial number.

\*RST: n/a (A \*RST does not change the assignment between connector types and calibration kits.)

**Example:** `MMEM:LOAD:CKIT 'C:\Users\Public\Documents\Rohde-Schwarz\Vna\Calibration\Kits\New Kit 1 (123456).calkit'`  
 Load the previously created cal kit file `New Kit 1 (123456).calkit` from the default cal kit directory.  
`CORR:CKIT:N50:LSEL 'New Kit 1', '123456'`  
 Assign the imported kit to the N 50  $\Omega$  connector type, assuming that the cal kit name stored in `New Kit 1 (123456).calkit` reads `New Kit 1` and that its label reads `123456`.

**Manual operation:** See ["Add / Copy / Delete / Standards..."](#) on page 405

---

**[SENSe:]CORRection:CKIT:<StandardType>:WLAbel <ConnType>, <CalKitName>, <CalKitLabel>, <StandardLabel>, <MinFreq>, <MaxFreq>, <DelayParam>, <Loss>, <Z0>, <C0>, <C1>, <C2>, <C3>, <L0>, <L1>, <L2>, <L3>, OPEN | SHORT | MATCH | <Resistance>[, <Port1>[, <Port2>]]**  
**[SENSe:]CORRection:CKIT:<StandardType>:WLAbel? <ConnType>, <CalKitName>[, <CalKitLabel>[, <Port1>[, <Port2>]]]]**

Defines the parameters of a non-ideal 1 port or 2-port calibration standard `<StandardType>`, where a particular cal kit can be addressed by name **and** label.

Apart from the additional `<CalKitLabel>` parameter, the syntax and semantics of this command is identical to [Standard types and their parameters](#).

**Example:** `CORR:CKIT:FOP:WLAb 'N 50 Ohm', 'New Kit 1', '123456', '', 0, 4000000000, 0, 0, 50, 99, -2.3, 0.22, 0, 0, 0, 0, 0`  
 Define the properties of the Open (f) standard for a N 50  $\Omega$  connector type in the calibration kit "New Kit 1" labelled "123456".  
`CORR:CKIT:FOP:WLAb? 'N 50 Ohm', 'New Kit 1', '123456'`  
 Query the properties of the Open (f) standard for a N 50  $\Omega$  connector type in the calibration kit.

**Manual operation:** See ["Add / Copy... / Delete / View / Modify..."](#) on page 407

---

**[SENSe:]CORRection:CKIT:<OnePortStandardType>:WLAbel:SDATa? <ConnectorType>, <CalKitName>[, <CalKitLabel>[, <PhysPort>]]**

Reads the S-parameter data for a particular **1-port** cal kit standard previously loaded from Touchstone file using `MMEMoRY:LOAD:CKIT:SDATa` or `MMEMoRY:LOAD:CKIT:SDATa:WLAbel`.

The cal kit is identified by its name and label.

**Query parameters:**

|                                                    |                                                                                                                                                                                                                                                                    |
|----------------------------------------------------|--------------------------------------------------------------------------------------------------------------------------------------------------------------------------------------------------------------------------------------------------------------------|
| <OnePort<br>StandardType>                          | MOPen   FOPen   MSHort   FSHort   MOShort   MOShort1  <br>MOShort2   MOShort3   FOSHort   FOSHort1   FOSHort2  <br>FOSHort3   MREFlect   FRElect   MMTCh   FMTCh  <br>MSMatch   FSMatch<br>Standard type.<br>For more information see <a href="#">Table 8-13</a> . |
| <ConnectorType>,<br><CalKitName>,<br><CalKitLabel> | Together with <StandardType> these parameters fully identify<br>the related standard (see <a href="#">Parameter list</a> ).                                                                                                                                        |
| <PhysPort>                                         | Number of the physical port for which the S-parameter data is<br>valid. Can be omitted if the data are valid for all ports.                                                                                                                                        |

**Usage:** Query only

**[SENSe:]CORRection:CKIT:<TwoPortStandard>:WLAbel:SDATa?**

<ConnectorType>, <CalKitName>[, <CalKitLabel>[, <SParameter>,  
<PhysPort1>, <PhysPort2>]]

Reads the S-parameter data for a particular **2-port** cal kit standard previously loaded  
from Touchstone file using [MMEMory:LOAD:CKIT:SDATa](#) or [MMEMory:LOAD:CKIT:  
SDATa:WLAbel](#).

The cal kit is identified by its name and label.

**Query parameters:**

|                                                    |                                                                                                                                                                                                                                                                                                                 |
|----------------------------------------------------|-----------------------------------------------------------------------------------------------------------------------------------------------------------------------------------------------------------------------------------------------------------------------------------------------------------------|
| <TwoPortStandard>                                  | MMThrough   MFThrough   FFThrough   MMLine   MMLine1  <br>MMLine2   MMLine3   MFLine   MFLine1   MFLine2   MFLine3  <br>FFLine   FFLine1   FFLine2   FFLine3   MMATten   MFATten  <br>FFATten   MMSNetwork   MFSNetwork   FFSNetwork<br>Standard type.<br>For more information see <a href="#">Table 8-13</a> . |
| <ConnectorType>,<br><CalKitName>,<br><CalKitLabel> | Together with <StandardType> these parameters fully identify<br>the related standard (see <a href="#">Parameter list</a> ).                                                                                                                                                                                     |
| <SParameter>                                       | S11   S12   S21   S22<br>S-parameter of the 2-port standard.                                                                                                                                                                                                                                                    |
| <PhysPort1>,<br><PhysPort2>                        | Numbers of the physical ports for which the S-parameter data is<br>valid. Can be omitted if the data are valid for all port pairs.                                                                                                                                                                              |

**Usage:** Query only

**8.3.14.8 [SENSe:]CORRection...**

The `[SENSe:]CORRection...` commands control the system error correction and  
measurement receiver (power) calibration.



|                                                                  |     |
|------------------------------------------------------------------|-----|
| [SENSe:]CORRection:COLLect:AUTO:CKIT.....                        | 910 |
| [SENSe:]CORRection:COLLect:AUTO:CKIT:PASSword.....               | 911 |
| [SENSe:]CORRection:COLLect:AUTO:CKIT:PORTs.....                  | 912 |
| [SENSe:]CORRection:COLLect:AUTO:CKIT:PORTs:ADD.....              | 913 |
| [SENSe:]CORRection:COLLect:AUTO:MCONnect.....                    | 913 |
| [SENSe:]CORRection:COLLect:AUTO:PORTs:CONNectiOn?.....           | 914 |
| [SENSe:]CORRection:COLLect:AVERAge.....                          | 914 |
| [SENSe:]CORRection:COLLect:CHANnels:ALL.....                     | 914 |
| [SENSe:]CORRection:COLLect:CHANnels:MCTypes.....                 | 915 |
| [SENSe<Ch>:]CORRection:COLLect:DETeCtor.....                     | 917 |
| [SENSe:]CORRection:COLLect:FIXTure:LMPArAmeter[:STATe].....      | 917 |
| [SENSe:]CORRection:COLLect:FIXTure:LMPArAmeter:LOSS[:STATe]..... | 917 |
| [SENSe<Ch>:]CORRection[:STATe].....                              | 918 |
| [SENSe<Ch>:]CORRection:COLLect[:ACQuire]:SELeCted.....           | 918 |
| [SENSe<Ch>:]CORRection:COLLect:AUTO.....                         | 920 |
| [SENSe<Ch>:]CORRection:COLLect:AUTO:CONFIgure.....               | 921 |
| [SENSe<Ch>:]CORRection:COLLect:AUTO:CPORt.....                   | 922 |
| [SENSe<Ch>:]CORRection:COLLect:AUTO:PORTs.....                   | 922 |
| [SENSe<Ch>:]CORRection:COLLect:AUTO:PORTs:TYPE.....              | 923 |
| [SENSe<Ch>:]CORRection:COLLect:AUTO:TYPE.....                    | 925 |
| [SENSe<Ch>:]CORRection:COLLect:CKIT:INSTAll.....                 | 926 |
| [SENSe<Ch>:]CORRection:COLLect:CKIT:LOAD.....                    | 927 |
| [SENSe<Ch>:]CORRection:COLLect:CKIT:PORT<PhyPt>?.....            | 927 |
| [SENSe<Ch>:]CORRection:COLLect:CONNectiOn<PhyPt>.....            | 927 |
| [SENSe<Ch>:]CORRection:COLLect:CONNectiOn:GENDErs.....           | 928 |
| [SENSe<Ch>:]CORRection:COLLect:CONNectiOn:PORTs.....             | 929 |
| [SENSe<Ch>:]CORRection:COLLect:DELeTe.....                       | 929 |
| [SENSe<Ch>:]CORRection:COLLect:DISCArD.....                      | 930 |
| [SENSe<Ch>:]CORRection:COLLect:FIXTure[:ACQuire].....            | 930 |
| [SENSe<Ch>:]CORRection:COLLect:FIXTure:EXPORt.....               | 931 |
| [SENSe<Ch>:]CORRection:COLLect:FIXTure:IMPORt.....               | 931 |
| [SENSe<Ch>:]CORRection:COLLect:FIXTure:SAVE.....                 | 932 |
| [SENSe<Ch>:]CORRection:COLLect:FIXTure:STARt.....                | 933 |
| [SENSe<Ch>:]CORRection:COLLect:LOAD:SELeCted.....                | 933 |
| [SENSe<Ch>:]CORRection:COLLect:METHod:DEFine.....                | 934 |
| [SENSe<Ch>:]CORRection:DELeTe.....                               | 936 |
| [SENSe<Ch>:]CORRection:COLLect:SAVE:SELeCted:DEFault.....        | 936 |
| [SENSe<Ch>:]CORRection:COLLect:SAVE:SELeCted[:DUMMy].....        | 937 |
| [SENSe<Ch>:]CORRection:COLLect:SCONNectiOn<PhyPt>.....           | 938 |
| [SENSe<Ch>:]CORRection:CONNectiOn.....                           | 938 |
| [SENSe<Ch>:]CORRection:CONNectiOn:CATAlOG?.....                  | 939 |
| [SENSe<Ch>:]CORRection:CONNectiOn:DELeTe.....                    | 940 |
| [SENSe<Ch>:]CORRection:DATA:PARAmeter<Sfk>?.....                 | 941 |
| [SENSe<Ch>:]CORRection:DATA:PARAmeter:COUNT?.....                | 943 |
| [SENSe<Ch>:]CORRection:DATE?.....                                | 943 |
| [SENSe<Ch>:]CORRection:EDELay:AUTO.....                          | 944 |
| [SENSe<Ch>:]CORRection:EDELay<PhyPt>:DIELeCtriC.....             | 944 |
| [SENSe<Ch>:]CORRection:EDELay<PhyPt>:DISTAnce.....               | 945 |
| [SENSe<Ch>:]CORRection:EDELay<PhyPt>:ELENgth.....                | 945 |
| [SENSe<Ch>:]CORRection:EDELay<PhyPt>[:TIME].....                 | 946 |

|                                                                          |     |
|--------------------------------------------------------------------------|-----|
| [SENSe:]CORRection:EDELay:VNETwork.....                                  | 946 |
| [SENSe<Ch>:]CORRection:EWAVe[:STATe].....                                | 947 |
| [SENSe<Ch>:]CORRection:LOSS<PhyPt>.....                                  | 947 |
| [SENSe<Ch>:]CORRection:LOSS<PhyPt>:SECond.....                           | 947 |
| [SENSe<Ch>:]CORRection:LOSS:AUTO.....                                    | 947 |
| [SENSe<Ch>:]CORRection:LOSS<PhyPt>:FREQUency.....                        | 948 |
| [SENSe<Ch>:]CORRection:LOSS<PhyPt>:SECond:FREQUency.....                 | 948 |
| [SENSe<Ch>:]CORRection:LOSS<PhyPt>:OFFSet.....                           | 948 |
| [SENSe<Ch>:]CORRection:LOSS<PhyPt>:SECond:STATe.....                     | 948 |
| [SENSe<Ch>:]CORRection:OFFSet<PhyPt>[:STATe].....                        | 949 |
| [SENSe<Ch>:]CORRection:OFFSet<PhyPt>:COMPensation[:STATe].....           | 949 |
| [SENSe<Ch>:]CORRection:OFFSet<PhyPt>:DFComp[:STATe]?.....                | 950 |
| [SENSe<Ch>:]CORRection:PCAL.....                                         | 950 |
| [SENSe<Ch>:]CORRection:POWer:DATA.....                                   | 951 |
| [SENSe<Ch>:]CORRection:POWer<PhyPt>[:STATe].....                         | 951 |
| [SENSe<Ch>:]CORRection:POWer<PhyPt>:ACQuire.....                         | 952 |
| [SENSe<Ch>:]CORRection:POWer<PhyPt>:AWAVe[:STATe].....                   | 953 |
| [SENSe<Ch>:]CORRection:STIMulus?.....                                    | 954 |
| [SENSe<Ch>:]CORRection:COLLect:AUTO:ASSignment:ALL:COUNT?.....           | 954 |
| [SENSe<Ch>:]CORRection:COLLect:AUTO:ASSignment:COUNT?.....               | 955 |
| [SENSe<Ch>:]CORRection:COLLect:AUTO:ASSignment:DEFine:DEFault.....       | 955 |
| [SENSe<Ch>:]CORRection:COLLect:AUTO:ASSignment:DEFine:TPORt:DEFault..... | 956 |
| [SENSe<Ch>:]CORRection:COLLect:AUTO:ASSignment:DELeTe:ALL.....           | 956 |
| [SENSe<Ch>:]CORRection:COLLect:AUTO:ASSignment<Asg>:ACQuire.....         | 956 |
| [SENSe<Ch>:]CORRection:COLLect:AUTO:ASSignment<Asg>:DEFine.....          | 957 |
| [SENSe<Ch>:]CORRection:COLLect:AUTO:ASSignment<Asg>:DEFine:TPORt.....    | 958 |
| [SENSe<Ch>:]CORRection:COLLect:AUTO:SAVE.....                            | 959 |
| [SENSe<Chn>:]CORRection:PS Tate?.....                                    | 959 |
| [SENSe<Chn>:]CORRection:SS Tate?.....                                    | 959 |

### [SENSe:]CORRection:COLLect:AUTO:CKIT <Characterization>

Generates a characterization (cal kit file) with the specified name containing the cal kit data of the active calibration unit (selected via `SYSTem:COMMunicate:RDEvice:AKAL:ADDReSS`). The cal kit file can be saved to a directory on the analyzer, to the calibration unit's internal (flash) memory or to an SD card inserted at the calibration unit (if available).

**Note** that this command can only be executed if the number of cal unit ports is less or equal to the number of test ports. Furthermore the command assumes the "canonical" assignment of cal unit ports to test ports: cal unit port 1 assigned to test port 1, cal unit port 2 assigned to test port 2 etc. The new command `[SENSe:]CORRection:COLLect:AUTO:CKIT:PORTs` allows for flexible assignments.

#### Setting parameters:

<Characterization> Location of the created characterization / cal kit file (string parameter, extension \*.calkit):  
 If a path is specified, the file is saved to the analyzer's hard disk.  
 The default directory (`MMEMory:CDIRectory`) is **not** used.

If only the file name is specified, the file is saved to the calibration unit's internal (flash) memory. The factory calibration data on the unit is not overwritten.

If the file name is prefixed by "SD:", the file is saved to the SD card inserted at the calibration unit (if available/accessible).

**Example:**

```
CORR:COLL:AUTO:CKIT 'AutoCalChar'
```

Generate a cal kit file `AutoCalChar.calkit` for the active calibration unit and store it in the calibration unit.

```
SENSe:CORRection:COLLect:AUTO:CKIT 'SD:test1'
```

Generate a cal kit file `test1.calkit` for the active calibration unit and store it in the calibration unit.

**Usage:**

Setting only

**Manual operation:** See ["File name / Comment \(Optional\)"](#) on page 413

---

**[SENSe:]CORRection:COLLect:AUTO:CKIT:PASSword <Password>**

Enters a password to enable a single password-protected action in the automatic calibration or in the characterization wizard. If password protection has been activated manually in the "Characterize Cal Unit" dialog, the password is required for any single execution of one of the following commands, provided that a cal kit (characterization) file different from the active characterization is specified:

```
[SENSe]:CORRection:COLLect:AUTO
```

```
[SENSe]:CORRection:COLLect:AUTO:CKIT
```

```
[SENSe]:CORRection:COLLect:AUTO:PORTs
```

```
[SENSe]:CORRection:COLLect:AUTO:PORTs:TYPE
```

```
[SENSe]:CORRection:COLLect:AUTO:TYPE
```

**Tip:** You have to send `[SENSe:]CORRection:COLLect:AUTO:CKIT:PASSword` repeatedly if your command script uses several password-protected commands. You do not need a password to perform automatic calibrations using the active cal unit characterization.

**Setting parameters:**

<Password> Password (string parameter), as defined in manual control.

**Example:**

```
SENSe:CORRection:COLLect:AUTO:CKIT:PASSword
'My_password'
```

Enter a password `My_password` (assuming that password protection has been activated manually).

```
SENSe:CORRection:COLLect:AUTO '', 1, 2
```

Perform an automatic 2-port calibration at test ports 1 and 2 using the calibration unit's default calibration kit file and automatic port assignment.

```
SENSe:CORRection:COLLect:AUTO:CKIT:PASSword
'My_password'
```

Re-enter the password.

```
SENSe:CORRection:COLLect:AUTO '', 1, 2
```

Repeat the calibration.

**Usage:** Setting only

**Manual operation:** See "[Authentication](#)" on page 410

---

**[SENSe:]CORRection:COLLect:AUTO:CKIT:PORTs** <Characterization>, <TestPort1>, <CalUnitPort1>[, <TestPort2>...]

Generates a characterization (cal kit file) with the specified name containing the cal kit data of the active calibration unit (`SYSTem:COMMunicate:RDEvice:AKAL:ADDRess`). The cal kit file can be saved to a directory on the analyzer, to the calibration unit's internal (flash) memory or to an SD card inserted at the calibration unit (if available).

Similar logic as `[SENSe:]CORRection:COLLect:AUTO:CKIT`, but with flexible port assignment.

**Setting parameters:**

<Characterization> Location of the created characterization / cal kit file (string parameter, extension \*.calkit):  
 If a path is specified, the file is saved to the analyzer's hard disk. The default directory (`MMEMory:CDIRectory`) is **not** used.  
 If only the file name is specified, the file is saved to the calibration unit's internal (flash) memory. The factory calibration data on the unit is not overwritten.  
 If the file name is prefixed by "SD:", the file is saved to the SD card inserted at the calibration unit (if available/accessible).

<TestPort1> Number of first test port.

<CalUnitPort1> Number of the calibration unit port to whom the first test port (<TestPort1>) is assigned.

<TestPort2> Number of second test port...

**Usage:** Setting only

**Manual operation:** See "[Test Port Assignment](#)" on page 412

---

```
[SENSe:]CORRection:COLLect:AUTO:CKIT:PORTs:ADD <Characterization>,
 <TestPort1>, <CalUnitPort1>[, <TestPort2>]...
```

Extends or modifies an *existing* characterization of the active calibration unit (`SYSTem:COMMunicate:RDEvice:AKAL:ADDRESS`).

This functionality is not available at the GUI.

#### Setting parameters:

<Characterization> Location of an existing characterization (e.g. created using `[SENSe:]CORRection:COLLect:AUTO:CKIT:PORTs`).

- A VNA cal kit file name `*.calkit` without path refers to a specific cal kit file stored in the internal memory of the active calibration unit.
- A VNA cal kit file name without path but prefixed with "SD:" refers to a specific cal kit file stored on the SD card inserted at the active calibration unit.
- A VNA cal kit file name `*.calkit` with path refers to a specific cal kit file stored in an arbitrary directory on the analyzer.

<TestPort1> Number of first test port.

<CalUnitPort1> Number of the calibration unit port, to whom test port <TestPort1> is assigned.

<TestPort2> Number of the second test port ...

#### Example:

Prerequisite:

```
SYSTem:COMMunicate:RDEvice:AKAL:ADDRESS
'MyCalU'
```

Sets 'MyCalU' as the active calibration unit.

```
SYSTem:COMMunicate:RDEvice:AKAL:PORTs? 'abc'
```

Queries the ports of characterization 'abc'; returns something like '3,N 50 Ohm,MALE,4,N 50 Ohm,MALE'. In particular, calibration unit ports 1 and 2 are not yet characterized.

```
SENSe:CORRection:COLLect:AUTO:CKIT:PORTs:ADD
'abc', 1, 2
```

Extend characterization 'abc' with test port 1 assigned to port 2 of the cal unit.

```
SYSTem:COMMunicate:RDEvice:AKAL:PORTs? 'abc'
```

Now returns something like '2,N 50 Ohm,MALE,3,N 50 Ohm,MALE,4,N 50 Ohm,MALE'.

```
SENSe:CORRection:COLLect:AUTO:CKIT:PORTs:ADD
'abc', 1, 2
```

Repeat characterization of test port 2, e.g. because the connection cable wasn't fastened correctly ...

**Usage:** Setting only

---

```
[SENSe:]CORRection:COLLect:AUTO:MCONnect <MinimumConnect>
```

Enables or disables the [Reduced Through](#) logic for every port assignment of an automatic calibration.

Note that for this to work, the port assignments must have a star topology, with a "Common Port" set using `[SENSe<Ch>:]CORRection:COLLect:AUTO:CPOrt` on page 922.

**Setting parameters:**

<MinimumConnect> ON (1), or OFF (0)

**Manual operation:** See ["Use Reduced Number of Through"](#) on page 521

**[SENSe:]CORRection:COLLect:AUTO:PORTs:CONNect?**

Returns the assignment between the physical analyzer ports and the ports of the connected automatic calibration unit.

**Example:**

```
CORR:COLL:AUTO:PORT ' ', 1, 2
```

Perform an automatic 1-port calibration at analyzer port 1, using the calibration unit's default calibration kit file and port 2 of the cal unit.

```
CORR:COLL:AUTO:PORT:CONN?
```

Query the actual port assignment. If the cal unit is properly connected according to the previous command, the response is 1,2,2,0. A zero means that the corresponding analyzer port is not connected to any port of the calibration unit.

**Usage:** Query only

**Manual operation:** See ["Detect Port Assignment"](#) on page 382

**[SENSe:]CORRection:COLLect:AVERage <Average>**

Activates automatic averaging, which means that the VNA may perform multiple calibration sweeps and apply averaging to reduce trace noise. In contrast to manual averaging (see `[SENSe<Ch>:]AVERage[:STATe]`) the number of calibration sweeps is calculated automatically.

**Parameters:**

<Average> AUTO | MANual

**Manual operation:** See ["Auto Averaging"](#) on page 521

**[SENSe:]CORRection:COLLect:CHANnels:ALL <Boolean>**

Enables calibration of all channels in the active recall set. The command is valid for the following calibration methods:

- Manual system error correction
- Automatic system error correction (cal unit)

A scalar power calibration is not affected.

**Parameters:**

<Boolean> ON – calibrate all channels.  
OFF – calibrate the active channel only.

**Example:** See `[SENSe<Ch>:]CORRection:COLLect:SAVE:SELected[:DUMMy]`

**Manual operation:** See "Calibrate all Channels" on page 387

---

**[SENSe:]CORRection:COLLect:CHANnels:MCTypes <Boolean>**

Toggles the **Multiple Calibration TTypes** mode that allows you to calibrate a subset of the available channels using channel-specific ports and calibration types (see [Chapter 5.5.7, "Parallel Calibration of Multiple Channels"](#), on page 172).

Enable the MCTypes mode before defining the calibrations to be performed using `[SENSe<Ch>:]CORRection:COLLect:METHod:DEFine`. Disable the MCTypes mode after the calibrations were saved using `[SENSe<Ch>:]CORRection:COLLect:SAVE:SELected[:DUMMy]`. The latter must be called only *once*, with <Ch> referring to one of the channels to be calibrated (see the example below).

**Parameters:**

<Boolean>

**Example:**

Suppose that there are 3 channels in the current recall set and you want to calibrate channels 1 and 2. For channel 1, you want to perform a Reflection Normalization (Short) on ports 1 and 2, for channel 2 an OSM calibration on port 2. This calibration requires measuring standards as shown in the table below. Proceed as follows:

```
:CORRection:COLLect:CHANnels:MCTYPes ON
```

Activate the MCTYPes mode.

```
:SENSe1:CORRection:COLLect:METHod:DEFine
```

```
'Parser Test SFK Ch1', RSHort, 1, 2
```

```
:SENSe2:CORRection:COLLect:METHod:DEFine
```

```
'Parser Test SFK Ch2', FOPort, 2
```

Declare the calibrations to be performed. Then connect the Short standard to port 1

```
:SENSe:CORRection:COLLect:ACQuire:SElected
```

```
SHORT, 1
```

Acquire calibration data for the short on port 1 (needed for calibration in channel 1). Then connect the Open standard to port 2.

```
:SENSe:CORRection:COLLect:ACQuire:SElected
```

```
OPEN, 2
```

Acquire calibration data for the open on port 2 (needed for calibration in channel 2). Then connect the Short standard to port 2.

```
:SENSe:CORRection:COLLect:ACQuire:SElected
```

```
SHORT, 2
```

Acquire calibration data for short on port 2 (needed for calibrations in channel 1 and 2). Then connect the Match standard to port 2.

```
:SENSe:CORRection:COLLect:ACQuire:SElected
```

```
MATCh, 2
```

Acquire calibration data for match on port 2 (needed for calibration in channel 2).

```
:SENSe1:CORRection:COLLect:SAVE:SElected
```

Complete all calibrations. This command is required only once and has to address one of the calibrated channels (channel 1 or 2 in this example).

```
:CORRection:COLLect:CHANnels:MCTYPes OFF
```

Deactivate the MCTYPes mode. Recommended for compatibility with manual operation.

|                                                                          | Port 1 | Port 2             |
|--------------------------------------------------------------------------|--------|--------------------|
| <b>Channel 1</b><br>Reflection Normalization(Short)<br>for ports 1 and 2 | Short  | Short              |
| <b>Channel 2</b><br>OSM for port 1                                       | -      | Open, Short, Match |



---

**[SENSe<Ch>:]CORRection:COLLect:DETEctor <CalName>[, <CalDetectorType>]**

Selects the detector type during manual calibration <CalName>.

**Suffix:**

<Ch> Channel number

**Parameters:**

<CalName> Name of a manual calibration previously created e.g. using  
[\[SENSe<Ch>:\]CORRection:COLLect:METhod:DEfIne](#)

<CalDetectorType> NORMal | AVERage

**AVERage**

Average detector, recommended for channels measuring traces using detectors other than the NORMal one

**NORMal**

Normal (sample) detector, recommended for all other applications

\*RST: NORMal

---

**[SENSe:]CORRection:COLLect:FIXTure:LMPParameter[:STATe] <Boolean>**

Selects an Auto Length (and Loss) calculation or a Direct Compensation.

**Parameters:**

<Boolean> 1 - Auto Length (and Loss), depending on the last  
[\[SENSe<Ch>:\]CORRection:COLLect:FIXTure:LMPParameter:LOSS\[:STATe\]](#) setting  
 0 - Direct Compensation  
 \*RST: 1

**Example:** See [\[SENSe<Ch>:\]CORRection:COLLect:FIXTure\[:ACQuire\]](#)

**Manual operation:** See "[Direct Compensation](#)" on page 448

---

**[SENSe:]CORRection:COLLect:FIXTure:LMPParameter:LOSS[:STATe] <Boolean>**

Selects an Auto Length or an Auto Length and Loss calculation.

**Parameters:**

<Boolean> 1 - Auto Length and Loss  
 0 - Auto Length, no loss  
 \*RST: 1

**Example:** See [\[SENSe<Ch>:\]CORRection:COLLect:FIXTure\[:ACQuire\]](#)

**Manual operation:** See "[Auto Length / Auto Length and Loss](#)" on page 447

---

**[SENSe<Ch>:]CORRection[:STATe] <Boolean>**

Enables or disables the system error correction for channel <Ch>.

**Suffix:**

<Ch>                      Calibrated channel number

**Parameters:**

<Boolean>                Enables (ON) or disables (OFF) the correction.

\*RST:                    ON

**Example:**

\*RST; :CORR?

Reset the instrument and query whether channel 1 is system error corrected. The response is 1.

**Manual operation:**    See "[User Cal Active](#)" on page 421

---

**[SENSe<Ch>:]CORRection:COLLect[:ACQuire]:SELected <Type>, <TestPort>[, <SecondPortOrAdapter>[, <Dispersion>[, <DelayTimePhase>]]]**

Starts the acquisition of measurement data for the selected standard and port(s). The standards are reflection or transmission standards and can be connected to arbitrary analyzer ports.

**Note:**

- The calibration measurement has a variable timeout:  $Timeout = (Sweep\ time / Number\ of\ sweep\ points) * 3 + 0.1\ s$
- For a sliding match, the R&S ZND can acquire measurement data for up to 20 positions per port. Multiple calls of `[SENSe<Ch>:]CORRection:COLLect[:ACQuire]:SELected SLIDe, <TestPort>` for the same test port, implicitly increases the position until position 20 has been recorded. Subsequent calls will start over at position 1, overwriting the previously acquired data.

**Suffix:**

<Ch>                      Channel number of the calibrated channel

**Setting parameters:**

<Type>                    THRough | OPEN | SHORt | OSHort | OSHort1 | OSHort2 | OSHort3 | MATCh | NET | ATT | REFL | SLIDe | ISOLation | LINE | LINE1 | LINE2 | LINE3 | UTHRough

Standard types: Through, Open, Short, Match, Symmetric Network (NET), Attenuation (ATT), Reflect, Sliding Match (SLIDe), Line1 (LINE1 and LINE are synonymous), Line2 and Line3 (esp. for TRL calibration), Offset Short 1 to 3 (OSHort), Unknown Through.

**ISOLation** is not a physical standard: to measure the isolation (supported for transmission normalization and TOSM only!) it is recommended to suitably terminate the related test ports (e.g. with 50 Ω loads).

|                          |                                                                                                                                                                                                                                                                                                                                                                                                                                                                                                                                                                                                                                                                                                                                                                                                                                                                                                                                                                                                                                                                                                                                                                                                                                                                                                                                                                                                                                                                                                                                                                                                                     |
|--------------------------|---------------------------------------------------------------------------------------------------------------------------------------------------------------------------------------------------------------------------------------------------------------------------------------------------------------------------------------------------------------------------------------------------------------------------------------------------------------------------------------------------------------------------------------------------------------------------------------------------------------------------------------------------------------------------------------------------------------------------------------------------------------------------------------------------------------------------------------------------------------------------------------------------------------------------------------------------------------------------------------------------------------------------------------------------------------------------------------------------------------------------------------------------------------------------------------------------------------------------------------------------------------------------------------------------------------------------------------------------------------------------------------------------------------------------------------------------------------------------------------------------------------------------------------------------------------------------------------------------------------------|
| <TestPort>               | <p>Test port number.<br/>For a transmission standard or an adapter that is used as a "through", the input and output port numbers must be specified. For reflection standards, only one port number is required.</p> <p>*RST: n/a</p>                                                                                                                                                                                                                                                                                                                                                                                                                                                                                                                                                                                                                                                                                                                                                                                                                                                                                                                                                                                                                                                                                                                                                                                                                                                                                                                                                                               |
| <SecondPortOrAdapter>    | <p>For a transmission standard or an adapter that is used as a "through", this parameter specifies the second test port. For reflection measurements with an adapter connected between port and standard, set it to ON. Otherwise set it to OFF or simply omit it.</p>                                                                                                                                                                                                                                                                                                                                                                                                                                                                                                                                                                                                                                                                                                                                                                                                                                                                                                                                                                                                                                                                                                                                                                                                                                                                                                                                              |
| <Dispersion>             | <p>Optional status parameter for UTHRough standard:<br/>OFF - unknown through standard is non-dispersive.<br/>ON - unknown through standard is dispersive.</p> <p>*RST: OFF</p>                                                                                                                                                                                                                                                                                                                                                                                                                                                                                                                                                                                                                                                                                                                                                                                                                                                                                                                                                                                                                                                                                                                                                                                                                                                                                                                                                                                                                                     |
| <DelayTimePhase>         | <p>Optional entry of delay time or phase for UTHRough standard:<br/>AUTO - the analyzer determines the delay time or phase during the calibration sweep.<br/>&lt;delay or phase&gt; - entry of the delay time in ps (for non-dispersive standards) or of the phase at the start frequency of the sweep in deg (for dispersive standards). If an estimate of the start phase is entered, the analyzer uses the <b>calculated</b> value which is closest to the estimate.</p> <p><b>Automatic determination of the phase</b><br/>The UOSM algorithm provides the transmission factor of the unknown through standard up to an ambiguous sign. This yields the two alternative phase values displayed in the calibration wizard; see Unknown Through Standard.<br/>In remote control, the analyzer performs a plausibility check in order to determine the correct phase. No manual selection is necessary. The check starts at the first sweep point, using the transmission factor with negative phase. The analyzer measures the phase at the subsequent sweep points, assuming that the phase difference between any two consecutive points is less than 90 deg. From these phase values, the analyzer calculates a linear extrapolation and derives an estimate for the DC phase limit. If this DC phase is in the vicinity of ... -180 deg, +180 deg, ... then the transmission factor with negative phase is adopted. If the DC phase is in the vicinity of ... 0 deg, +360 deg, ... then the transmission factor with inverted sign (corresponding to a 180 deg phase shift) is adopted.</p> <p>*RST: AUTO</p> |
| <b>Example:</b>          | <p>See <a href="#">[SENSe&lt;Ch&gt;:]CORRection:COLLect:SAVE:SELected[:DUMMy]</a> or <a href="#">Chapter 9.2.5.4, "Adapter Removal"</a>, on page 1141</p>                                                                                                                                                                                                                                                                                                                                                                                                                                                                                                                                                                                                                                                                                                                                                                                                                                                                                                                                                                                                                                                                                                                                                                                                                                                                                                                                                                                                                                                           |
| <b>Usage:</b>            | <p>Setting only</p>                                                                                                                                                                                                                                                                                                                                                                                                                                                                                                                                                                                                                                                                                                                                                                                                                                                                                                                                                                                                                                                                                                                                                                                                                                                                                                                                                                                                                                                                                                                                                                                                 |
| <b>Manual operation:</b> | <p>See <a href="#">"Start Cal Sweep"</a> on page 391</p>                                                                                                                                                                                                                                                                                                                                                                                                                                                                                                                                                                                                                                                                                                                                                                                                                                                                                                                                                                                                                                                                                                                                                                                                                                                                                                                                                                                                                                                                                                                                                            |

**[SENSe<Ch>:]CORRection:COLLect:AUTO** <Characterization>, <TestPort>[, <TestPort>]...

Selects and initiates an automatic calibration for the specified test ports using a single, auto-detected port assignment.

**Tip:**

- If the test setup contains a high attenuation, the analyzer may fail to detect the cal unit ports connected to each of its ports. In this case use the extended command `[SENSe<Ch>:]CORRection:COLLect:AUTO:PORTs`.
- Use `[SENSe<Ch>:]CORRection:COLLect:AUTO:TYPE` if you want to specify a particular calibration type for the automatic calibration.
- If several calibration units are connected, use `SYSTem:COMMunicate:RDEvice:AKAL:ADDRess` to select a unit for the calibration.

**Suffix:**

<Ch> Channel number of the calibrated channel

**Setting parameters:**

<Characterization> Location of the characterization (cal kit file) to be used for the automatic calibration (string parameter):

- If an empty string ( ' ' ) is specified, the factory cal kit file stored in the active calibration unit is used.
- A VNA cal kit file name `*.calkit` without path refers to a specific cal kit file stored in the internal memory of the active calibration unit.
- A VNA cal kit file name without path but prefixed with "SD:" refers to a specific cal kit file stored on the SD card inserted at the active calibration unit.
- A VNA cal kit file name `*.calkit` with path refers to a specific cal kit file stored in an arbitrary directory on the analyzer.

<TestPort>

<TestPort> Test port numbers. For an n-port automatic calibration, n arbitrary (not necessarily consecutive) port numbers must be specified. The analyzer automatically detects the calibration unit ports connected to each analyzer port.

**Example:**

`CORR:COLL:AUTO '', 1, 2, 4`

Perform an automatic 3-port calibration at test ports 1, 2, and 4 using the calibration unit's default calibration kit file and arbitrary test ports of the cal unit.

**Usage:** Setting only

**Manual operation:** See ["Apply/Cancel"](#) on page 384

**[SENSe<Ch>:]CORRection:COLLect:AUTO:CONFIgure <CalType>,  
<Characterization>[, <CalName>]**

Selects a calibration type and a cal unit characterization (cal kit file) for an automatic calibration.

**Suffix:**

<Ch> Channel number of the calibrated channel

**Parameters:**

<CalType> FNPort | TOSM | FOPort | OPTPort | FRTRans | FTRans |  
RTRans | REFL | RSHort

Calibration Type

**FNPort**

Full n-port (UOSM) calibration

**TOSM**

Full n-port calibration with characterized Through.

If the selected cal unit characterization does not contain a Through characterization, the command silently falls back to a FNPort (UOSM) calibration.

**FOPort**

Full one-port ("Refl OSM") calibration

**OPTPort**

"One Path Two Ports" calibration

If the selected cal unit characterization does not contain a Through characterization, the command will fail.

**FRTRans**

Transmission normalization, bidirectional

If the selected cal unit characterization does not contain a Through characterization, the command will fail.

**FTRans | RTRans**

Transmission normalization, forward | reverse

If the selected cal unit characterization does not contain a Through characterization, the command will fail.

**REFL**

Reflection normalization, Open

**RSHort**

Reflection normalization, Short

<Characterization> Location of the characterization (cal kit file) to be used for the automatic calibration (string parameter):

- The empty string ( ' ' ) refers to the factory calibration of (and stored on) the active calibration unit.
- A VNA cal kit file name \*.calkit without path refers to a specific cal kit file stored in the internal memory of the active calibration unit.
- A VNA cal kit file name without path but prefixed with "SD:" refers to a specific cal kit file stored on the SD card inserted at the active calibration unit.

– A VNA cal kit file name \*.calkit with path refers to a specific cal kit file stored in an arbitrary directory on the analyzer.

**Setting parameters:**

<CalName>

**Example:**

```
SENSE1:CORREction:COLLect:AUTO:CONFigure
FNPort, ''
```

Sets the automatic calibration to "Full n-port" with factory characterization.

**[SENSe<Ch>:]CORREction:COLLect:AUTO:CPOrt <PortNumber>**

Defines the "Common Port" of an automatic calibration.

This port will be part of every port assignment that is defined using [\[SENSe<Ch>:\]CORREction:COLLect:AUTO:ASSignment:DEFine:DEFault](#), or [\[SENSe<Ch>:\]CORREction:COLLect:AUTO:ASSignment:DEFine:TPORT:DEFault](#) on page 956.

If [\[SENSe:\]CORREction:COLLect:AUTO:MCONnect](#) is ON, this port will be used as the center of all Through measurements. If you set up the port assignments manually, make sure that every port assignment contains it.

**Suffix:**

<Ch> Channel number

**Setting parameters:**

<PortNumber> Number of the common port

**Usage:** Setting only

**Manual operation:** See ["Common Port"](#) on page 380

**[SENSe<Ch>:]CORREction:COLLect:AUTO:PORTs <Characterization>, <TestPort1>, <CalUnitPort1>[, <TestPort2>]...**

Selects and initiates an automatic calibration at arbitrary analyzer and calibration unit ports. A progress monitor for the calibration sweeps is displayed.

**Tip:**

- This command is necessary if the analyzer fails to detect the cal unit ports connected to each of its ports (e.g. because of a high attenuation in the test setup). If auto-detection works you can use the simpler command [\[SENSe<Ch>:\]CORREction:COLLect:AUTO](#).
- If several calibration units are connected, use [SYSTEM:COMMunicate:RDEvice:AKAL:ADDRess](#) to select a unit for the calibration.

**Suffix:**

<Ch> Channel number of the calibrated channel

**Setting parameters:**

<Characterization>

Location of the characterization (cal kit file) to be used for the automatic calibration (string parameter):

- If an empty string ( ' ' ) is specified, the factory cal kit file stored in the active calibration unit is used.

- A VNA cal kit file name `*.calkit` without path refers to a specific cal kit file stored in the internal memory of the active calibration unit.

- A VNA cal kit file name without path but prefixed with "SD:" refers to a specific cal kit file stored on the SD card inserted at the active calibration unit.

- A VNA cal kit file name `*.calkit` with path refers to a specific cal kit file stored in an arbitrary directory on the analyzer.

|                |                                                                                                                                                                                                                                                   |
|----------------|---------------------------------------------------------------------------------------------------------------------------------------------------------------------------------------------------------------------------------------------------|
| <TestPort1>    | Test port numbers. For an n-port automatic calibration, n arbitrary (not necessarily consecutive) port numbers must be specified.                                                                                                                 |
| <CalUnitPort1> | Port numbers of the cal unit. For an n-port automatic calibration, n arbitrary (not necessarily consecutive) port numbers must be specified. It is possible to combine arbitrary (not necessarily matching) pairs of analyzer and cal unit ports. |
| <TestPort2>    |                                                                                                                                                                                                                                                   |

**Example:** `CORR:COLL:AUTO:PORT ' ', 1, 2`  
Perform an automatic 1-port calibration at analyzer port 1, using the calibration unit's default calibration kit file and port 2 of the cal unit.

**Usage:** Setting only

**Manual operation:** See "[Apply/Cancel](#)" on page 384

---

**[SENSe<Ch>:]CORRection:COLLect:AUTO:PORTs:TYPE** <CalType>[, <Characterization>[, <TestPort1>[, <CalUnitPort1>[, <TestPort2>]...]]]

Selects and initiates an automatic calibration at arbitrary test and calibration unit ports. A progress monitor for the calibration sweeps is displayed.

**Tip:** This command is necessary if the analyzer fails to detect the cal unit ports connected to each of its ports (e.g. because of a high attenuation in the test setup). If auto-detection works you can use the simpler command `[SENSe<Ch>:]CORRection:COLLect:AUTO:TYPE`.

**Suffix:**

<Ch> Channel number of the calibrated channel

**Setting parameters:**

<CalType> FNPort | TOSM | FOPort | OPTPort | FRTRans | FTRans | RTRans | REFL | RSHort

Calibration Type

**FNPort**

Full n-port (UOSM) calibration

**TOSM**

Full n-port calibration with characterized Through.  
If the selected cal unit characterization does not contain a Through characterization, the command silently falls back to a FNPort (UOSM) calibration.

**FOPort**

Full one-port ("Refl OSM") calibration

**OPTPort**

"One Path Two Ports" calibration  
If the selected cal unit characterization does not contain a Through characterization, the command will fail.

**FRTRans**

Transmission normalization, bidirectional  
If the selected cal unit characterization does not contain a Through characterization, the command will fail.

**FTRans | RTRans**

Transmission normalization, forward | reverse  
If the selected cal unit characterization does not contain a Through characterization, the command will fail.

**REFL**

Reflection normalization, Open

**RShort**

Reflection normalization, Short

|                                 |                                                                                                                                                                                                                                                                                                                                                                                                                                                                                                                                                                                                                                                                                                                                                                                                |
|---------------------------------|------------------------------------------------------------------------------------------------------------------------------------------------------------------------------------------------------------------------------------------------------------------------------------------------------------------------------------------------------------------------------------------------------------------------------------------------------------------------------------------------------------------------------------------------------------------------------------------------------------------------------------------------------------------------------------------------------------------------------------------------------------------------------------------------|
| <b>&lt;Characterization&gt;</b> | <p>Location of the characterization (cal kit file) to be used for the automatic calibration (string parameter):</p> <ul style="list-style-type: none"> <li>– If an empty string ( ' ' ) is specified, the factory cal kit file stored in the active calibration unit is used.</li> <li>– A VNA cal kit file name <code>*.calkit</code> without path refers to a specific cal kit file stored in the internal memory of the active calibration unit.</li> <li>– A VNA cal kit file name without path but prefixed with "SD:" refers to a specific cal kit file stored on the SD card inserted at the active calibration unit.</li> <li>– A VNA cal kit file name <code>*.calkit</code> with path refers to a specific cal kit file stored in an arbitrary directory on the analyzer.</li> </ul> |
| <b>&lt;TestPort1&gt;</b>        | <p>Test port number. For an n-port automatic calibration, n arbitrary (not necessarily consecutive) port numbers must be specified. For a one path two port calibration (OPTPort), the first port no. denotes the source port (fully calibrated port).</p>                                                                                                                                                                                                                                                                                                                                                                                                                                                                                                                                     |
| <b>&lt;CalUnitPort1&gt;</b>     | <p>Port numbers of the cal unit. For an n-port automatic calibration, n arbitrary (not necessarily consecutive) port numbers must be specified. It is possible to combine arbitrary (not necessarily matching) pairs of analyzer and cal unit ports.</p>                                                                                                                                                                                                                                                                                                                                                                                                                                                                                                                                       |
| <b>&lt;TestPort2&gt;</b>        | <p>Second test port number</p> <p>*RST:        n/a</p>                                                                                                                                                                                                                                                                                                                                                                                                                                                                                                                                                                                                                                                                                                                                         |



- Example:** `CORR:COLL:AUTO:PORT FNPort, '', 1, 2, 2, 4, 4, 1`  
 Perform an automatic full 3-port calibration at test ports 1, 2, and 4 using the calibration unit's default calibration kit file and ports 2, 4, and 1 of the cal unit.
- Usage:** Setting only
- Manual operation:** See "[Calibration Type / Source](#)" on page 379

---

**[SENSe<Ch>:]CORRection:COLLect:AUTO:TYPE <CalType>[, <Characterization>[, <TestPort1>[, <TestPort2>]...]]**

Selects and initiates an automatic calibration at arbitrary analyzer and cal unit ports. This command also selects the calibration type. A progress monitor for the calibration sweeps is displayed.

**Tip:** If the test setup contains a high attenuation the analyzer may fail to detect the cal unit ports connected to each of its ports. In this case use the extended command `[SENSe<Ch>:]CORRection:COLLect:AUTO:PORTs:TYPE`.

If several calibration units are connected, use `SYSTem:COMMUnicate:RDEvice:AKAL:ADDRes` to select a unit for the calibration.

**Suffix:**  
 <Ch> Channel number of the calibrated channel

**Setting parameters:**  
 <CalType> FNPort | TOSM | FOPort | OPTPort | FRTRans | FTRans | RTRans | REFL | RSHort  
 Calibration Type

**FNPort**

Full n-port (UOSM) calibration

**TOSM**

Full n-port calibration with characterized Through.

If the selected cal unit characterization does not contain a Through characterization, the command silently falls back to a FNPort (UOSM) calibration.

**FOPort**

Full one-port ("Refl OSM") calibration

**OPTPort**

"One Path Two Ports" calibration

If the selected cal unit characterization does not contain a Through characterization, the command will fail.

**FRTRans**

Transmission normalization, bidirectional

If the selected cal unit characterization does not contain a Through characterization, the command will fail.

**FTRans | RTRans**

Transmission normalization, forward | reverse

If the selected cal unit characterization does not contain a Through characterization, the command will fail.

**REFL**

Reflection normalization, Open

**RShort**

Reflection normalization, Short

|                                 |                                                                                                                                                                                                                                                                                                                                                                                                                                                                                                                                                                                                                                                                                                                                                                                          |
|---------------------------------|------------------------------------------------------------------------------------------------------------------------------------------------------------------------------------------------------------------------------------------------------------------------------------------------------------------------------------------------------------------------------------------------------------------------------------------------------------------------------------------------------------------------------------------------------------------------------------------------------------------------------------------------------------------------------------------------------------------------------------------------------------------------------------------|
| <b>&lt;Characterization&gt;</b> | <p>Location of the characterization (cal kit file) to be used for the automatic calibration (string parameter):</p> <ul style="list-style-type: none"> <li>– The empty string ( ' ' ) refers to the factory calibration of (and stored on) the active calibration unit.</li> <li>– A VNA cal kit file name <code>*.calkit</code> without path refers to a specific cal kit file stored in the internal memory of the active calibration unit.</li> <li>– A VNA cal kit file name without path but prefixed with "SD:" refers to a specific cal kit file stored on the SD card inserted at the active calibration unit.</li> <li>– A VNA cal kit file name <code>*.calkit</code> with path refers to a specific cal kit file stored in an arbitrary directory on the analyzer.</li> </ul> |
| <b>&lt;TestPort1&gt;</b>        | <p>Test port numbers. For an n-port automatic calibration, n arbitrary (not necessarily consecutive) port numbers must be specified.</p>                                                                                                                                                                                                                                                                                                                                                                                                                                                                                                                                                                                                                                                 |
| <b>&lt;TestPort2&gt;</b>        | <p>Second test port number of the analyzer</p>                                                                                                                                                                                                                                                                                                                                                                                                                                                                                                                                                                                                                                                                                                                                           |
| <b>Example:</b>                 | <pre>CORR:COLL:AUTO:TYPE FNPort, '', 1, 2, 4</pre> <p>Perform an automatic full 3-port calibration at test ports 1, 2, and 4 using the calibration unit's default calibration kit file and arbitrary test ports of the cal unit.</p>                                                                                                                                                                                                                                                                                                                                                                                                                                                                                                                                                     |
| <b>Usage:</b>                   | <p>Setting only</p>                                                                                                                                                                                                                                                                                                                                                                                                                                                                                                                                                                                                                                                                                                                                                                      |
| <b>Manual operation:</b>        | <p>See <a href="#">"Calibration Type / Source"</a> on page 379</p>                                                                                                                                                                                                                                                                                                                                                                                                                                                                                                                                                                                                                                                                                                                       |

---

**[SENSe<Ch>:]CORRection:COLLect:CKIT:INSTall** <CalKitFile>, <Gender>[, <Ports>]

Allows you to load cal kit data by gender:

- From the given file
- To the given ports or all ports

Use [MMEMory:CKIT:INFO?](#) on page 845 to get information about cal kit files.

**Suffix:**

<Ch> Channel number

**Setting parameters:**

<CalKitFile>

<Gender> MALE | FEMale | NGENder

<Ports> Either a comma-separated list of port numbers or ALL (optional)

**Usage:** Setting only

**[SENSe<Ch>:]CORRection:COLLect:CKIT:LOAD** <CalKitName>, <KitLabel>, <Gender>[, <Ports>]

Allows you to load cal kit data by name, label and gender:

- From the pool
- To the given ports or all ports

**Suffix:**

<Ch> Channel number

**Setting parameters:**

<CalKitName> The name of the cal kit to be loaded

<KitLabel> The label of the cal kit to be loaded

<Gender> MALE | FEMale | NGENder  
The gender of the cal kit to be loaded

<Port> Either a comma-separated list of port numbers or ALL (optional)

**Usage:** Setting only

**[SENSe<Ch>:]CORRection:COLLect:CKIT:PORT<PhyPt>?** [<Detail>]

Queries the cal kit data assigned to the given port via

- [SENSe<Ch>:]CORRection:COLLect:CKIT:LOAD  
or [SENSe<Ch>:]CORRection:COLLect:CKIT:INSTall

**Suffix:**

<Ch> Channel number

<PhyPt> Port number

**Query parameters:**

<Detail> CONNector | LABEL | NAME | GENDER  
Queried property

**Return values:**

<Result>

**Usage:** Query only

**[SENSe<Ch>:]CORRection:COLLect:CONNectioN<PhyPt>** <ConnectorType>

Selects a connector type at a specified port <PhyPt> and its gender.

**Tip:** Use [SENSe<Ch>:]CORRection:COLLect:SCONNectioN<PhyPt> to select an arbitrary connector type using a string variable.

**Suffix:**

<Ch> Channel number of the calibrated channel

<PhyPt>

Port numbers of the analyzer

**Note:** If the analyzer is set to use the same connectors at all ports (`[SENSe<Ch>:]CORRection:COLLect:CONNectio:n:PORTs ALL`), then a change of a connector type is valid for all ports. The gender of the connectors can still be different.

**Parameters:**

<ConnectorType>

N50Female | N50Male | N75Female | N75Male | PC7 | SMAFemale | SMAMale | PC35female | PC35male | PC292female | PC292male | PC24female | PC24male | PC185female | PC185male | S7\_16female | S7\_16male | BNC50male | BNC50female | BNC75male | BNC75female | UFEMale1 | UMALe1 | UFEMale2 | UMALe2

Connector type and gender of the connectors (omitted for query). The R&S ZVR-compatible parameters `UFEMALE1` and `UMALE1` denote the user-defined connector type "UserConn1", `UFEMALE2` and `UMALE2` denote the user-defined connector type "UserConn2". The user-defined connector types must be defined before being addressed by

```
[SENSe<Ch>:]CORRection:COLLect:
CONNectio:n<PhyPt>.
```

\*RST: N50FEMALE for all ports.

**Example:**

```
*RST; :CORR:COLL:CONN1 N75MALE; CONN4?
Change the connector type at port 1 from N50FEMALE to
N75MALE. The connector type at the other ports is also
changed to N75, however, the gender (female) is maintained.
CORR:COLL:CONN4? returns N75FEMALE.
```

**Manual operation:** See "[Connector](#)" on page 230

**[SENSe<Ch>:]CORRection:COLLect:CONNectio:n:GENDeRs <Gender>**

Qualifies whether the genders at the test ports (but not their connector types) are equal or independent.

**Suffix:**

<Ch> Channel number of the calibrated channel

**Parameters:**

<Gender>

ALL | SINGLe

ALL – equal (uniform) genders. If the gender at one port is changed, the connector type at all other ports is changed accordingly.

SINGLe – independent (possibly non-uniform) genders at the ports.

\*RST: SINGLe

**Example:** See `[SENSe<Ch>:]CORRection:COLLect:CONNection:PORTs`

**Manual operation:** See "Same Connector All Ports / Same Gender All Ports" on page 389

### `[SENSe<Ch>:]CORRection:COLLect:CONNection:PORTs <ConnectorType>`

Qualifies whether the connector types at the test ports (but not their gender) are equal or independent. Some calibration types require uniform port connector types.

**Suffix:**

<Ch> Channel number of the calibrated channel

**Parameters:**

<ConnectorType> ALL | SINGle  
 ALL – equal (uniform) connector types. If the connector type at one port is changed, the connector type at all other ports is changed accordingly.  
 SINGle – independent (possibly non-uniform) connector types at the ports.  
 \*RST: ALL

**Example:**

```
CORR:COLL:CONN:PORTS SING
Select independent connector types at the ports.
CORR:COLL:CONN1 N50MALE; CONN4 N75FEMALE;
CONN2?
Select independent connector types at ports 1 and 4. The connector type at port 2 is not changed; the query returns
N50FEMALE.
```

**Manual operation:** See "Same Connector All Ports / Same Gender All Ports" on page 389

### `[SENSe<Ch>:]CORRection:COLLect:DELeTe [<CalName>]`

Deletes system error correction data generated and stored previously.

**Suffix:**

<Ch> Channel number of the calibrated channel

**Setting parameters:**

<CalName> Name of the calibration (string parameter) defined together with the calibration type (`[SENSe<Ch>:]CORRection:COLLect:METhod:DEFine`).  
 ALL - the analyzer deletes all calibrations.  
 If nothing is specified the analyzer deletes the last system error correction stored by means of `[SENSe<Ch>:]CORRection:COLLect:SAVE:SELeCted[:DUMMy]`.  
 \*RST: -

**Example:** `CORR:COLL:METH:DEF 'Test',RShort,1`  
 Select a one-port normalization at port 1 with a short standard as calibration type.  
`CORR:COLL:SEL SHOR,1`  
 Measure a short standard connected to port 1 and store the measurement results of this standard.  
`CORR:COLL:SAVE:SEL`  
`CORR:COLL:DEL ALL`  
 Calculate the system error correction data and apply it to the active channel, then delete the data.

**Usage:** Setting only

**Manual operation:** See "Apply" on page 392

---

### [SENSe<Ch>:]CORRection:COLLect:DISCard

Terminates a system error correction, discarding the acquired data.

**Suffix:**

<Ch> Channel number of the calibrated channel

**Example:**

```
:SENSe1:CORRection:COLLect:METhod:DEfine 'Test', TOSM, 1, 2
:SENSe1:CORRection:COLLect:ACQuire:SElected THROugh, 1, 2
:SENSe1:CORRection:COLLect:ACQuire:SElected OPEN, 1
:SENSe1:CORRection:COLLect:ACQuire:SElected SHORt, 1
:SENSe1:CORRection:COLLect:ACQuire:SElected MATCh, 1
:SENSe1:CORRection:COLLect:ACQuire:SElected OPEN, 2
:SENSe1:CORRection:COLLect:ACQuire:SElected MATCh, 2
:SENSe1:CORRection:COLLect:DISCard
```

**Usage:** Event

---

### [SENSe<Ch>:]CORRection:COLLect:FIXTure[:ACQuire] <StandardType>, <TestPort1>[, <TestPort2>]...

Starts a fixture compensation sweep in order to acquire measurement data for a test fixture that has its inner conductor terminated with the selected standards.

**Suffix:**

<Ch> Channel number of the corrected channel

**Setting parameters:**

<StandardType> OPEN | SHORT  
 Terminating standard type: open or short.

<TestPort1>

<TestPort2> Test port numbers. For a fixture compensation, n arbitrary (not necessarily consecutive) port numbers must be specified.

\*RST: -

**Example:**

```
*RST; CORR:COLL:FIXT:LMP:LOSS OFF
```

Configure a fixture compensation measurement (for all channels): The analyzer performs an Auto Length (no loss) calculation.

```
CORR:COLL:FIXT:ACQ OPEN, 2; :CORR:COLL:FIXT:ACQ SHOR, 4
```

Perform a fixture compensation sweep at port 2, terminated with an open standard, and at port 4, terminated with a short.

```
CORR:COLL:FIXT:SAVE
```

Save and apply the compensation data.

```
CORR:COLL:FIXT:STAR
```

Prepare a new fixture compensation measurement, deleting the previous data for channel 1.

```
CORR:COLL:FIXT:LMP OFF
```

Select a Direct Compensation measurement (for all channels and traces).

```
CORR:COLL:FIXT:ACQ SHOR, 1, 3
```

Perform a fixture compensation sweep at ports 1 and 3, terminated with a short standard.

```
CALC2:PAR:SDEF 'Trc2', 'S22'
```

Create channel no. 2 with a trace named Trc2.

```
SENS2:CORR:COLL:FIXT:STAR
```

Prepare a fixture compensation measurement for channel 2. The channel 1 data is not affected.

```
SENS2:CORR:COLL:FIXT:ACQ SHOR, 1, 3
```

Repeat the previous fixture compensation sweep for channel 2.

```
SENS1:CORR:COLL:FIXT:SAVE; :SENS2:CORR:COLL:FIXT:SAVE
```

Save and apply the compensation data for both channels.

```
SENS1:CORR:OFFS3:DFC?; :SENS2:CORR:OFFS3:DFC?
```

Query whether the analyzer uses Direct Compensation results at port 3. The response is 1;1 (true for both channels).

**Usage:**

Setting only

**Manual operation:** See "[Measure Fixture wizard](#)" on page 448

---

```
[SENSe<Ch>:]CORRection:COLLect:FIXTure:EXPort <FixtureFile>,
 <StandardType>, <TestPort1>[, <TestPort2>]...
```

```
[SENSe<Ch>:]CORRection:COLLect:FIXTure:IMPort <FixtureFile>,
 <StandardType>, <TestPort1>[, <TestPort2>]...
```

Loads/saves "Direct Compensation" data from/to the specified file.

The EXPort command first acquires the required data, just as a [SENSe<Ch>:]CORRection:COLLect:FIXTure[:ACQuire] would do.

"Direct Compensation" data files are standard [Trace Files](#), containing reflection parameter traces for the related port(s) and standard.

Table 8-14: Direct Compensation data

| #TestPorts | File Type |
|------------|-----------|
| 1          | s1p       |
| >=1        | csv       |

For 1-port Touchstone files (\*.s1p) only a single test port can be specified - otherwise an error is raised.

**Suffix:**

<Ch> Channel number

**Parameters:**

<FixtureFile> Path to the "Direct Compensation" data file, either absolute or relative to the current directory (set/queried using [MMEMory:CDIRectory](#))

**Setting parameters:**

<StandardType> OPEN | SHORT  
Terminating standard type

<TestPort1>[,  
<TestPort2>, ...] Test port numbers. For a fixture compensation, n different (but not necessarily consecutive) port numbers must be specified.

**Example:**

```
*RST; SENSE1:CORR:COLL:FIXT:LMP OFF
```

Activate "Direct Compensation".

```
SENSE1:CORR:COLL:FIXT:EXP 'Traces\p12_short.csv', SHOR, 1, 2
```

Acquire "Direct Compensation" data for ports 1 and 2 (whose inner connectors have to be terminated with a Short) and save the acquired data to file.

In a subsequent measurement session you can load and apply these data as follows:

```
*RST;
:SENSE1:CORR:COLL:FIXT:LMP OFF
:SENSE1:CORR:COLL:FIXT:IMP 'Traces\p12short.csv', SHOR, 1, 2
:SENSE1:CORR:COLL:FIXT:SAVE
```

**Usage:** Setting only

**Manual operation:** See "[Measure Fixture wizard](#)" on page 448

**[SENSe<Ch>:]CORRection:COLLect:FIXTure:SAVE**

Completes a fixture compensation, storing and applying the acquired data.

**Suffix:**

<Ch> Channel number of the corrected channel

**Example:**

See [\[SENSe<Ch>:\]CORRection:COLLect:FIXTure\[:ACQUIRE\]](#)

**Usage:** Event



**Manual operation:** See ["Measure Fixture wizard"](#) on page 448

---

### [SENSe<Ch>:]CORRection:COLLect:FIXTure:START

Prepares the analyzer for fixture compensation comprising a single or a series of fixture compensation sweeps

([SENSe<Ch>:]CORRection:COLLect:FIXTure[:ACQuire]). Previous compensation data is deleted.

**Suffix:**

<Ch> Channel number of the corrected channel

**Example:** See [SENSe<Ch>:]CORRection:COLLect:FIXTure[:ACQuire]

**Usage:** Event

**Manual operation:** See ["Measure Fixture wizard"](#) on page 448

---

### [SENSe<Ch>:]CORRection:COLLect:LOAD:SElected <CalGroupFile>, <Standard>, <TestPort1>[, <SecondPortOrAdapter>]

Reloads a set of previously acquired calibration data for a particular standard from a file in the cal pool. The loaded data may be combined with new calibration measurement data ([SENSe<Ch>:]CORRection:COLLect[:ACQuire]:SElected) in order to simplify and speed up the new calibration procedure. The channel settings for loaded and new calibrations (e.g. the number of sweep points) must be identical.

**Note:**

- The analyzer performs a consistency check for the loaded data. If the loaded file is incompatible with the channel settings of channel <Ch>, or if it does not contain data for the specified standard and port(s), a command error message (-100, "Command error;...") is generated.
- For a sliding match, the R&S ZND can acquire and load measurement data for up to 20 positions per port. Multiple calls of [SENSe<Ch>:]CORRection:COLLect:LOAD:SElected <CalGroupFile>, SLIDE, <TestPort> for the same cal group file and test port, implicitly increases the position until position 20 has been recorded. Subsequent calls will start over at position 1, overwriting the previously loaded data.

**Suffix:**

<Ch> Channel number of the calibrated channel

**Parameters:**

<CalGroupFile> String parameter to specify the name of the loaded cal group file.

<Standard> THROugh | OPEN | SHORt | OSHort | OSHort1 | OSHort2 | OSHort3 | MATCh | NET | ATT | REFL | SLIDe | ISOLation | LINE | LINE1 | LINE2 | LINE3 | UTHRough

See [SENSe<Ch>:]CORRection:COLLect[:ACQuire]:SElected on page 918.

<TestPort1> Test port number. For a transmission standard (through, line, attenuation, symmetric network) or an adapter used as a "through" the input and output port numbers must be specified. For reflection standards, only one port number is required.

**Setting parameters:**

<SecondPortOrAdapter> For a transmission standard or an adapter used as a "through" this parameter specifies the second test port. For reflection measurements with an adapter connected between port and standard, set it to ON. Otherwise set it to OFF or simply omit it.

**Example:**

Suppose that the cal pool contains a file 'Calgroup3.cal' with a valid through calibration for the active channel no. 1, which you want to include in a new TOSM calibration for ports 1 and 2.

```
MMEM:CDIR DEF; CDIR 'Calibration\Data'
```

Go to the cal group directory.

```
:SENSe1:CORRection:COLLect:MEthod:DEFine 'New Cal', TOSM, 1, 2
```

Define a new TOSM calibration.

```
SENSe1:CORRection:COLLect:LOAD:SElected 'Cal Group 3.cal', THROUGH, 1, 2
```

Load the through data from the cal pool file into the new calibration.

```
SENSe1:CORRection:COLLect:ACquire:SElected OPEN, 1
```

Proceed with the new calibration measurements.

**Manual operation:** See ["Start Cal Sweep"](#) on page 391

---

```
[SENSe<Ch>:]CORRection:COLLect:MEthod:DEFine <CalName>, <CalType>, <TestPort1>[, <TestPort2>[, <TestPort3orAdapterCalKit>[, <TestPorts>]...]]
```

Defines the calibration to be performed for channel <Ch>.

If multiple channels shall be calibrated in parallel, use

- [SENSe:]CORRection:COLLect:CHANnels:ALL ON or
- [SENSe:]CORRection:COLLect:CHANnels:MCTypes ON

before executing this command. For background information see [Chapter 5.5.7, "Parallel Calibration of Multiple Channels"](#), on page 172.

Calibration data is acquired using [SENSe<Ch>:]CORRection:COLLect[:ACquire]:SElected.

**Suffix:**

<Ch> Channel number

**Parameters:**

<CalName> Name of the calibration (string parameter). The name serves as a reference to delete a particular set of system correction data ([SENSe<Ch>:]CORRection:COLLect:DElete).

|                              |                                                                                                                                                                                                                                                                                                                                                                                                                                                                                            |
|------------------------------|--------------------------------------------------------------------------------------------------------------------------------------------------------------------------------------------------------------------------------------------------------------------------------------------------------------------------------------------------------------------------------------------------------------------------------------------------------------------------------------------|
| <CalType>                    | ARTosm   ARPTosm   REFL   RSHort   FOPort   FTRans   RTRans   FRTRans   OPTPort   TOSM   UOSM   TRL   TOM   TSM   TRM   TNA<br>Calibration types; see list below.                                                                                                                                                                                                                                                                                                                          |
| <TestPort1>                  | First calibrated test port number. For an n-port calibration type, n port numbers must be specified. If more than n numbers are defined, the spare numbers (the last ones in the list) are ignored. Entering less than n numbers causes an error message. For a one path two port calibration (OPTPort), the first port no. denotes the node port (fully calibrated port).                                                                                                                 |
| <TestPort2>                  | Second calibrated port number.                                                                                                                                                                                                                                                                                                                                                                                                                                                             |
| <TestPort3 or AdapterCalKit> | Either the third calibrated port number, or - for Adapter Removal calibrations only - the file path (relative to the current directory) where the analyzer shall store the adapter characterization obtained during the calibration.<br>The latter is optional. If a file path is provided the characterization file (in Touchstone s2p format) is generated when the correction terms are finally calculated ( <code>[SENSe&lt;Ch&gt;:]CORRection:COLLect:SAVE:SElected[:DUMMY]</code> ). |
| <TestPorts>                  | More ports to be calibrated.                                                                                                                                                                                                                                                                                                                                                                                                                                                               |

**Example:**

```
:SENSE1:CORRECTION:COLLECT:METHOD:DEFINE
'Test', ARTosm, 1,2, 'Adapter.s2p'
```

Initiate an Adapter Removal calibration for ports 1 and 2 on channel 1 and store the adapter characterization in <MEMORY:CDIR?>\Adapter.s2p.  
For another example see `[SENSe<Ch>:]CORRection:COLLect:SAVE:SElected[:DUMMY]`.

**Manual operation:** See "[Type/Source](#)" on page 387

The supported calibration types are listed below.

**Note:** For a unidirectional R&S ZND (see [Chapter 5.1.4.3, "R&S ZND: Unidirectional vs. Bidirectional Operation"](#), on page 75) "bidirectional calibrations" are not available.

| Parameter                 | Type ("Calibration Presetting" dialog)                                                                                                                                   |
|---------------------------|--------------------------------------------------------------------------------------------------------------------------------------------------------------------------|
| ARTosm                    | Adapter Removal                                                                                                                                                          |
| REFL   RSHort             | Refl Norm Open   Refl Norm Short                                                                                                                                         |
| FOPort                    | Full One Port ("Refl OSM")                                                                                                                                               |
| FTRans   RTRans   FRTRans | Trans Norm - Forward   Trans Norm - Reverse   Trans Norm Both<br>"Forward" ("Reverse") means that the port with the smaller (larger) port number serves as a drive port. |
| OPTPort                   | One Path Two Ports                                                                                                                                                       |
| TOSM                      | TOSM                                                                                                                                                                     |

| Parameter                   | Type ("Calibration Presetting" dialog) |
|-----------------------------|----------------------------------------|
| UOSM                        | UOSM                                   |
| TRL   TOM   TSM   TRM   TNA | TRL   TOM   TSM   TRM   TNA            |

---

### [SENSe<Ch>:]CORRection:DELeTe

Cleans the channel's existing calibration data and also removes links to the calibration pool.

**Suffix:**

<Ch>                      Channel number

**Usage:**

Event

**Manual operation:**    See "[Remove all Cal Data](#)" on page 422

---

### [SENSe<Ch>:]CORRection:COLLect:SAVE:SELeCted:DEFault

Generates a set of default system error correction data for the selected ports and calibration type. The default data set corresponds to a test setup which does not introduce any systematic errors; none of the measurement results acquired previously (`[SENSe<Ch>:]CORRection:COLLect[:ACQuire]:SELeCted`) is taken into account.

**Tip:** The main purpose of the default correction data set is to provide a dummy system error correction which you can replace with your own, external correction data. You may have acquired the external data in a previous session or even on an other instrument. If you want to use the external correction data on the analyzer, simply generate the default data set corresponding to your port configuration and calibration type and overwrite the default data. For details refer to the program example below.

**Suffix:**

<Ch>                      Channel number of the calibrated channel.

**Example:**

```
CORR:COLL:METH:DEF 'Test',RShort,1
```

Select a one-port normalization at port 1 with a short standard as calibration type.

```
CORR:COLL:SAVE:SEL:DEF
```

Calculate a dummy system error correction for the normalization at port 1. The dummy system error correction provides the reflection tracking error term 'REFLTRACK'.

```
CORR:CDAT? 'REFLTRACK',1,0
```

Query the dummy system error correction term. The response is a 1 (written as 1,0 for the real and imaginary part) for each sweep point (no attenuation and no phase shift between the analyzer and the calibration plane).

```
INIT:CONT OFF; :INIT; *WAI
```

Stop the sweep to ensure correct transfer of calibration data.

```
CORR:CDAT 'REFLTRACK',1,0,<ASCII_data>
```

Replace the dummy system error correction term with your own correction data, transferred in ASCII format.

```
INIT:CONT ON
```

Restart the sweep in continuous mode.

**Usage:** Event

**Manual operation:** See "Apply" on page 392

### [SENSe<Ch>]:CORRection:COLLect:SAVE:SELected[:DUMMy]

Calculates the system error correction data from the acquired measurement results ([SENSe<Ch>]:CORRection:COLLect[:ACQuire]:SELected), stores it and applies it to the calibrated channel(s). To avoid incompatibilities, older system error correction data is deleted unless it has been transferred into a cal pool (MMEMory:STORe:CORRection <Ch>, '<file\_name>').

**Suffix:**

<Ch> One of the calibrated channels  
 If [SENSe]:CORRection:COLLect:CHANnels:ALL is ON this suffix can be omitted

**Example:**

```
CORRection:COLLect:METHod:DEFine 'Test',RShort,1
```

Select a one-port normalization at port 1 with a short standard as calibration type.

```
CORRection:COLLect:CHANnels:ALL ON
```

Enable calibration in all channels of the active recall set.

```
CORRection:COLLect:SELected SHOR,1
```

Measure a short standard connected to port 1 and store the measurement results of this standard.

```
CORRection:COLLect:SAVE:SELected
```

Calculate the system error correction data and apply it to all channels of the active recall set.

**Usage:** Event

**Manual operation:** See "Apply" on page 392

---

**[SENSe<Ch>:]CORRection:COLLect:SCONnection<PhyPt> <Type>[, <Gender>]**

Selects a connector type at a specified port <PhyPt> and its gender. In contrast to [\[SENSe<Ch>:\]CORRection:COLLect:CONNECTION<PhyPt>](#), this command uses a string variable to identify the connector type.

**Suffix:**

<Ch> Channel number of the calibrated channel

<PhyPt> Port numbers of the analyzer. If the analyzer is set to use the same connectors at all ports ([\[SENSe<Ch>:\]CORRection:COLLect:CONNECTION:PORTs ALL](#)), then a change of a connector type is valid for all ports. The gender of the connectors can still be different.

**Parameters:**

<Type> Connector type (string parameter) of the connectors. See "Cal kit naming conventions" under [\[SENSe:\]CORRection:CKIT:<ConnType>:SElect](#).

\*RST: 'N 50 Ohm',FEM for all ports.

<Gender> MALE | FEMale

Gender of the connectors. The gender designation is not necessary (and ignored) for sexless connector types.

**Example:**

\*RST; :CORR:COLL:SCON1 'N 75 Ohm', MALE; SCON4?  
Change the connector type at port 1 from 'N 50 Ohm', FEM to 'N 75 Ohm', MALE. The connector type at the other ports is also changed to N 75 Ohm, however, the gender (female) is maintained. [CORR:COLL:SCON4?](#) returns 'N 75 Ohm', FEM.

**Manual operation:** See "[Connector / Gender](#)" on page 388

---

**[SENSe<Ch>:]CORRection:CONNECTION <ConnectorName>[, <Mode>[, <Gender>[, <RelPermittivity>[, <Reflmpedance>]]]]]**

Configures the user-defined connector types.

**Suffix:**

<Ch> Channel number

**Parameters:**

<ConnectorName> Name of the user-defined connectors, string parameter.

<Mode> TEM | WGUide

Transverse electric or waveguide type propagation mode.

<Gender> GENDER | NGENER

GENDER – polar connector type (m/f)  
NGENDER – sexless connector type

|                   |                                                                                                                                                                                                                                                                                         |
|-------------------|-----------------------------------------------------------------------------------------------------------------------------------------------------------------------------------------------------------------------------------------------------------------------------------------|
| <RelPermittivity> | Relative permittivity<br>Range: 0.0000000001 to 1000.                                                                                                                                                                                                                                   |
| <ReflImpedance>   | For TEM type connectors: reference impedance in $\Omega$ (without unit), For waveguide ( <i>wG<sub>U</sub>ide</i> ) type connectors: cutoff frequency in Hz (without unit).<br>Range: Ref. impedance: 1 $\mu\Omega$ to 1000 M $\Omega$ . Cutoff frequency: 0 Hz to 1000 GHz.<br>*RST: - |

**Example:**

```
CORR:CONN 'USERCON', TEM, GEND, 1.00000, 50
Define a TEM type connector type named USERCON.
CORR:CONN? 'USERCON'
Query the properties of the configured connector type.
CORR:CONN:DEL 'USERCON'
Delete the configured connector type.
```

**Manual operation:** See "[Connector / Gender](#)" on page 388

---

#### [SENSe<Ch>:]CORRection:CONNection:CATalog?

Returns a list of the connector types of all calibration kits in use.

**Suffix:**

<Ch> Channel number. This suffix is ignored because connector types are channel-independent.

- Example:** CORRection:CONNection:CATalog?  
 Query connector types. Possible response: 'N 50 Ohm,N 75 Ohm,7 mm,3.5 mm,2.92 mm,2.4 mm,1.85 mm,7-16,Type F (75),BNC 50 Ohm,BNC 75 Ohm,SMA,4.3-10,User Conn 1'  
 CORRection:CKIT:CATalog? 'N 50 Ohm'  
 Query cal kits for N (50 Ω) connector types. Possible response: 'N 50 Ohm Ideal Kit,3653,85054D,ZV-Z121,ZCAN 50 Ohm,ZV-Z21 typical,85032B/E,85032F,85054B,New Kit 1'. We assume that a cal kit New Kit 1 with label 2012-05-25 was created before.  
 CORRection:CKIT:LCATalog? 'N 50 Ohm'  
 Query cal kits for N (50 Ω) connector types with their labels. Possible response: 'N 50 Ohm Ideal Kit,,3653,,85054D,,ZV-Z121,,ZCAN 50 Ohm,,ZV-Z21 typical,,85032B/E,,85032F,,85054B,,New Kit 1,2012-05-25'. A sequence of two commas means that the preceding cal kit has no label assigned.  
 CORRection:CKIT:STANdard:CATalog? '85032B/E'  
 Query standards in cal kit named 85032B/E. Possible response: 'MOP,FOP,MSH,FSH,MMMT,FMMT,MFTH'  
 CORRection:CKIT:STANdard:LCATalog? 'New Kit 1','2012-05-25'  
 Query standards in user cal kit named New Kit 1 labelled 2012-05-25. Possible response: 'MOP,FOP,MSH(P1),FSH,MMMT,FMMT,MSM,FSM,MREF,FREF,MOSHORT2,FOSHORT2,MOSHORT3,FOSHORT3,MMTH,MMTH(P2P3)...' (P1 etc. denote restricted port assignments).
- Usage:** Query only
- Manual operation:** See "[Connector / Gender](#)" on page 388

---

**[SENSe<Ch>:]CORRection:CONNection:DELeTe <ConnectorName>**

Deletes a user-defined connector type named <ConnectorName>.

**Suffix:**

<Ch> Channel number

**Setting parameters:**

<ConnectorName> Name of the user-defined connectors, string parameter.

**Example:** See [\[SENSe<Ch>:\]CORRection:CONNection](#)

**Usage:** Setting only

**Manual operation:** See "[Connector / Gender](#)" on page 388



**[SENSe<Ch>:]CORRection:DATA:PARAmeter<Sfk>? [<SfkSettingType>[, <Index>]]**

Gets the settings of the active system error correction (or of the factory calibration, if no channel calibration is active).

**Suffix:**

<Ch> Number of the calibrated channel.

<Sfk> Number of the system error correction.  
Must be omitted or set to 1.

**Query parameters:**

<SfkSettingType> ACAL | START | STOP | POINTs | SPOWer | STYPE | BANDwidth | PDLY | RATTenuation | TYPE | PORTs | SPORT | THRoughs | TSTamp | LTSTamp | TVNA | MVNA | MTEST | CKIT | FSMODE

The requested setting.

If no <SfkSettingType> is specified, the values for START, STOP, POINTs, SPOWer and STYPE are returned

**ACAL**

1 for automatic calibrations, 0 for manual calibrations

**START**

Start frequency (or CW frequency, if no frequency sweep is active)

**STOP**

Stop frequency (or CW frequency, if no frequency sweep is active)

**POINTs**

Number of points

**SPOWer**

Source power (or stop power, for power sweeps)

**STYPE**

Sweep type or grid (LIN, LOG, SEGM)

**BANDwidth**

Measurement bandwidth

**PDLY**

Point delay (Meas Delay) for OSM

**RATTenuation**

Receiver attenuations: comma-separated list containing a value pair <port no.>,<rec. att.> (float,integer) for each of the involved

**PORTs**

**TYPE**

Calibration type (see <Type> parameter in [\[SENSe<Ch>:\]CORRection:COLLect\[:ACQUIRE\]:SElected](#) on page 918)

**PORTs**

The related test port numbers (comma-separated list of integers)

**SPORT**

For SMARTer calibrations this indicates the port to which a powermeter was connected

**THRoughs**

Measured Throughs: comma-separated list of directed port number pairs <pno1-pno2>

**TSTamp**

Timestamp in UTC

**LTSTamp**

Timestamp in local time

**TVNA**

For calibrations involving switch matrices, this indicates the test ports on the VNA itself. Returns a comma-separated list of port pairs `TestPort, VnaPort`

**MVNA**

For calibrations involving switch matrices, this indicates the mapping between matrix ports and VNA ports for matrix <Index>. Returns a comma-separated list of port pairs `MatrixVnaPort, VnaPort`

**MTEST**

For calibrations involving switch matrices, this indicates the mapping between matrix (physical) test ports and test ports for matrix <Index>. Returns a comma-separated list of port pairs `MatrixTestPort, TestPort`

**CKIT**

If created with FW version 2.30 or higher, for each port the name of the used calibration kit is stored with a calibration.

The query can return one of the following:

**the cal kit name** (string)

if available and unique

**'Multiple'**

if cal kit names are available but not unique, i.e. if <PhyPt> was not specified and multiple cal kits were used (multi-port calcs with different connector types, merged calcs)

**'Unknown'**

if cal kit names are not available (calcs created with a FW version < 2.30)

<Index>

If one or more external switch matrices were used during calibration, this refers to the index of a particular switch matrix (see [SYSTEM:COMMunicate:RDEvice:SMATrix<Matr>:DEFine](#) on page 1034)

**Example:**                   SENSE:CORRection:DATA:PARAmeter?

Unrestricted query. Result looks like this:  
 100000,8500000000,201,-10,LIN  
 SENSE:CORRection:DATA:PARAmeter? START  
 ...  
 SENSE:CORRection:DATA:PARAmeter? STYPE  
 Query settings one by one.  
 SENSE:CORRection:DATA:PARAmeter? RATTenuation  
 Query receiver attenuations. Result looks like this:  
 1,0.000000,2,0.000000

**Usage:**                    Query only

**Manual operation:**    See "Apply" on page 392

---

#### [SENSe<Ch>:]CORRection:DATA:PARAmeter:COUNT?

Gets the number of active system error corrections for channel <Ch>.

For the R&S ZND the result is 0 (uncalibrated) or 1 (calibrated). The properties of the active system error correction can be queried using [SENSe<Ch>:]CORRection:DATA:PARAmeter<Sfk>?.

**Suffix:**  
 <Ch>                    Channel number

**Usage:**                    Query only

---

#### [SENSe<Ch>:]CORRection:DATE?

Returns the date and time when the active system error correction data for channel <Ch> was acquired (see example).

**Suffix:**  
 <Ch>                    Channel number of the calibrated channel

**Example:**

```
CORR:COLL:METH REFL1
```

Select a one-port normalization at port 1 as calibration type.

```
CORR:COLL:OPEN1
```

Measure an open standard connected to port 1 and store the measurement results of this standard.

```
CORR:COLL:SAVE
```

Calculate the system error correction data and apply it to the active channel.

```
CORR:DATE?
```

Query the time when the system error correction became active. The analyzer returns the date and time, e.g. '03/20/11,18:30:39'.

```
CORR:DATA:PAR?
```

Query the sweep settings for the calibration sweep. The analyzer returns the start and stop frequency, the number of points, source power, and the sweep type, e.g. 300000,8000000000,201,0,LIN.

```
CORR:SST?
```

Query the calibration status. The analyzer returns 'CAL OFF' (because the performed one-port calibration is not sufficient for the measured transmission S-parameter  $S_{21}$ ).

**Usage:** Query only

**Manual operation:** See "Apply" on page 392

---

#### [SENSe<Ch>:]CORRection:EDELay:AUTO <Activate>

Applies the [Auto Length](#) function to the active trace of channel <Ch>.

Use [CALCulate<Chn>:STATistics:DOMain:USER](#) commands to limit the frequency range for the calculation.

#### Suffix:

<Ch> Channel number

#### Setting parameters:

<Activate> ONCE  
Applies the auto length function.

**Example:** \*RST; :CORR:EDEL:AUTO ONCE  
Reset the instrument and apply the auto length function to the default trace (Trc1 in channel 1).

**Usage:** Setting only

**Manual operation:** See "Auto Length" on page 446

---

#### [SENSe<Ch>:]CORRection:EDELay<PhyPt>:DIElectric <Permittivity>

Defines the permittivity for the offset correction at test port <PhyPt>.

**Suffix:**

<Ch> Channel number of the offset-corrected channel

<PhyPt> Port number of the analyzer

**Parameters:**

<Permittivity> Permittivity

Range: 1 to +1E+6

\*RST: 1.00062

**Example:** See [\[SENSe<Ch>:\]CORRection:EDELay<PhyPt>:ELENgth](#)

**Manual operation:** See ["Permittivity / Velocity Factor"](#) on page 445

**[SENSe<Ch>:]CORRection:EDELay<PhyPt>:DISTance <MechLength>**

Defines the offset parameter for test port <PhyPt> as a mechanical length.

**Suffix:**

<Ch> Channel number of the offset-corrected channel

<PhyPt> Port number of the analyzer

**Parameters:**

<MechLength> Mechanical length

Range: -3.402823466E+038 m to +3.4028234664E+038 m.

\*RST: 0 m

Default unit: m

**Example:** See [\[SENSe<Ch>:\]CORRection:EDELay<PhyPt>:ELENgth](#)

**Manual operation:** See ["Delay / Electrical Length / Mech. Length"](#) on page 444

**[SENSe<Ch>:]CORRection:EDELay<PhyPt>:ELENgth <ElecLength>**

Defines the offset parameter for test port <PhyPt> as an electrical length.

**Suffix:**

<Ch> Channel number of the offset-corrected channel

<PhyPt> Port number of the analyzer

**Parameters:**

<ElecLength> Electrical length

Range: -1E+9 m to +1E+9 m.

Increment: 1 mm

\*RST: 0 m

Default unit: m

**Example:**

```
CORR:EDEL2:ELEN 0.3
```

Define an electrical length of 30 cm for channel 1 and port no. 2.

```
CORR:EDEL2:DIST?; DIEL?
```

Query the values of the mechanical length and the permittivity at port 2. The mechanical length is equal to the electrical length divided by the square root of the permittivity; the latter is set to its default value. The response is 0.29990704322; 1.00062.

```
CORR:EDEL2?
```

Query the value of the delay at port 2. The delay is equal to the electrical length divided by the speed of light in the vacuum, so the response is 1.0006922856E-009.

```
CORR:LOSS2 2; LOSS2:FREQ 1.5 GHz; OFFS 3 dB
```

Define the offset loss parameters at port 2.

**Manual operation:** See ["Delay / Electrical Length / Mech. Length"](#) on page 444

**[SENSe<Ch>:]CORRection:EDELay<PhyPt>[:TIME] <Delay>**

Defines the offset parameter for test port <PhyPt> as a delay time.

**Suffix:**

<Ch> Channel number of the offset-corrected channel

<PhyPt> Port number of the analyzer

**Parameters:**

<Delay> Delay

Range: -3.40282346638529E+038 s to  
+3.40282346638529E+038 s.

\*RST: 0 s

Default unit: s

**Example:** See [\[SENSe<Ch>:\]CORRection:EDELay<PhyPt>:ELENgth](#)

**Manual operation:** See ["Delay / Electrical Length / Mech. Length"](#) on page 444

**[SENSe:]CORRection:EDELay:VNETwork <Boolean>**

Changes the position of the offset calculation in the "Offset Embed" calculation chain.

**Parameters:**

<Boolean> **OFF (0)**

The offset is calculated **before** de-/embedding (default).

**ON (1)**

The offset is calculated **after** de-/embedding.

\*RST: 0

**Manual operation:** See ["Offset > Calculate after De-/Embed."](#) on page 476

---

**[SENSe<Ch>:]CORRection:EWAVE[:STATe]** <Boolean>

Activates or deactivates the wave correction logic for wave quantities and ratios.

**Suffix:**

<Ch> Channel number

**Parameters:**

<Boolean> \*RST: ON (1)

---

**[SENSe<Ch>:]CORRection:LOSS<PhyPt>** <LossAtFrequency>

**[SENSe<Ch>:]CORRection:LOSS<PhyPt>:SECond** <LossAtFrequency>

These commands define the [offset loss](#) at the reference frequencies  $f_1$  and  $f_2$ .

The reference frequencies can be set using [\[SENSe<Ch>:\]CORRection:LOSS<PhyPt>:FREQUENCY](#) and [\[SENSe<Ch>:\]CORRection:LOSS<PhyPt>:SECond:FREQUENCY](#).

**Suffix:**

<Ch> Channel number

<PhyPt> Physical port number

**Parameters:**

<LossAtFrequency> Loss at reference frequency  
 Range: -200 dB to +200 dB  
 Increment: 0.001 dB  
 \*RST: 0 dB  
 Default unit: dB

**Manual operation:** See "[Loss at DC / Loss at 1st Freq / 1st Freq for Loss / Use 2nd Freq / Loss at 2nd Freq / 2nd Freq for Loss](#)" on page 435

---

**[SENSe<Ch>:]CORRection:LOSS:AUTO** <Activate>

Applies the [Auto Length and Loss](#)) function to the active trace of channel <Ch>.

Use [CALCulate<Chn>:STATistics:DOMain:USER](#) commands to limit the frequency range for the calculation.

**Suffix:**

<Ch> Channel number

**Setting parameters:**

<Activate> ONCE  
 Required constant

**Example:**

\*RST; :CORR:LOSS:AUTO ONCE  
 Reset the instrument and apply the "Auto Length and Loss" function to the default trace (Trc1 in channel 1).

**Usage:** Setting only

**Manual operation:** See "[Auto Length and Loss](#)" on page 450

---

---

**[SENSe<Ch>:]CORRection:LOSS<PhyPt>:FREQUency <RefFreq>**  
**[SENSe<Ch>:]CORRection:LOSS<PhyPt>:SECond:FREQUency <RefFreq>**

These commands define the reference frequencies  $f_1$  and  $f_2$  for the [offset loss](#) approximation.

The corresponding losses can be defined using [\[SENSe<Ch>:\]CORRection:LOSS<PhyPt>:OFFSet](#).

**Suffix:**

<Ch> Channel number  
 <PhyPt> Physical port number

**Parameters:**

<RefFreq> Reference frequency  
 Range: Frequency range of the analyzer model.  
 Increment: 1 MHz  
 \*RST: 1000000000 Hz (= 1 GHz)  
 Default unit: Hz

**Manual operation:** See "[Loss at DC / Loss at 1st Freq / 1st Freq for Loss / Use 2nd Freq / Loss at 2nd Freq / 2nd Freq for Loss](#)" on page 435

---

**[SENSe<Ch>:]CORRection:LOSS<PhyPt>:OFFSet <OffsetLoss>**

Defines the frequency-independent part (DC value) of the offset loss.

**Suffix:**

<Ch> Channel number of the offset-corrected channel  
 <PhyPt> Port number of the analyzer

**Parameters:**

<OffsetLoss> Frequency-independent part of the offset loss  
 Range: -200 dB to +200 dB  
 Increment: 0.001 dB  
 \*RST: 0 dB  
 Default unit: dB

**Example:** See [\[SENSe<Ch>:\]CORRection:EDELay<PhyPt>:ELENgth](#)

**Manual operation:** See "[Loss at DC / Loss at 1st Freq / 1st Freq for Loss / Use 2nd Freq / Loss at 2nd Freq / 2nd Freq for Loss](#)" on page 435

---

**[SENSe<Ch>:]CORRection:LOSS<PhyPt>:SECond:STAtE <Boolean>**

Defines whether the second reference frequency  $f_2$  is used for the [offset loss](#) approximation.

The second reference frequency and its associated loss value can be defined using [\[SENSe<Ch>:\]CORRection:LOSS<PhyPt>:SECond:FREQUency](#) and [\[SENSe<Ch>:\]CORRection:LOSS<PhyPt>:SECond](#).



**Suffix:**

|         |                      |
|---------|----------------------|
| <Ch>    | Channel number       |
| <PhyPt> | Physical port number |

**Parameters:**

|           |                                            |
|-----------|--------------------------------------------|
| <Boolean> | <b>OFF (0)</b><br>$f_2$ not used (default) |
|           | <b>ON (1)</b><br>$f_2$ used                |

**Manual operation:** See "[Loss at DC / Loss at 1st Freq / 1st Freq for Loss / Use 2nd Freq / Loss at 2nd Freq / 2nd Freq for Loss](#)" on page 435

**[SENSe<Ch>:]CORRection:OFFSet<PhyPt>[:STATe]** <Boolean>

Resets the offset parameters for all test ports to zero and the reference frequency to 1 GHz or queries whether any of the offset parameters are different from zero.

**Suffix:**

|         |                                                                                                               |
|---------|---------------------------------------------------------------------------------------------------------------|
| <Ch>    | Channel number of the offset-corrected channel                                                                |
| <PhyPt> | Port number of the analyzer. This numeric suffix is ignored; the command affects the parameters of all ports. |

**Parameters:**

|           |                                                                                                                                                                                                                                                                                                                                                                                         |
|-----------|-----------------------------------------------------------------------------------------------------------------------------------------------------------------------------------------------------------------------------------------------------------------------------------------------------------------------------------------------------------------------------------------|
| <Boolean> | The parameter function depends on whether the command is used as a setting command or as a query: For setting command:<br>ON - no effect<br>OFF - resets all length offsets to zero and the reference frequency to 1 GHz<br>For query:<br>1 - at least one length offset parameter is different from its default value<br>0 - all length offsets are zero / set to default<br>*RST: OFF |
|-----------|-----------------------------------------------------------------------------------------------------------------------------------------------------------------------------------------------------------------------------------------------------------------------------------------------------------------------------------------------------------------------------------------|

**Example:**

\*RST; :CORR:OFFS?

Reset the instrument and query whether the length offset parameters have been reset as well. The response is 0.

**Manual operation:** See "[Reset Offsets](#)" on page 436

**[SENSe<Ch>:]CORRection:OFFSet<PhyPt>:COMPensation[:STATe]** <Boolean>

Toggles length/loss/fixture compensation for physical port <PhyPt> ON/OFF.

**Suffix:**

|         |                      |
|---------|----------------------|
| <Ch>    | Channel number       |
| <PhyPt> | Physical port number |

**Parameters:**

<Boolean> ON (1): compensation active  
OFF (0): compensation inactive

**Manual operation:** See ["Active"](#) on page 435

**[SENSe<Ch>:]CORRection:OFFSet<PhyPt>:DFComp[:STATe]?**

Returns whether a direct fixture compensation has been carried out at port no. <PhyPt>. A direct fixture compensation resets the offset parameters to zero, the analyzer uses calculated transmission factors instead.

**Suffix:**

<Ch> Channel number of the offset-corrected channel  
<PhyPt> Port number of the analyzer.

**Return values:**

<Boolean> 1 - direct fixture compensation data used  
0 - no direct fixture compensation data used

**Example:**

```
*RST; CORR:OFFS:DFC?
```

Reset the instrument and query whether the analyzer uses direct fixture compensation data at port 1. The response is 0.

**Usage:** Query only

**Manual operation:** See ["Direct Compensation"](#) on page 448

**[SENSe<Ch>:]CORRection:PCAL <ActivatePowerCals>**

Activates or deactivates all power calibrations.

**Suffix:**

<Ch> Calibrated channel number

**Setting parameters:**

<ActivatePowerCals> NONE | ALL

NONE – deactivate all power calibrations.

ALL – activate all power calibrations.

```
*RST: n/a
```

**Example:**

```
*RST; CORR:POW:ACQ AWAVE,1,PORT,1
```

Perform a receiver power calibration of the wave a<sub>1</sub> using port 1 as a source port, assuming that the transmitted source power a<sub>1</sub> is correct. No external cabling is needed.

```
CORR:POW:AWAV?
```

Check whether the calibration is applied (the response is 1).

```
CORR:PCAL NONE; POW:AWAV?
```

Disable all power calibrations and check again whether the calibration is applied (the response is 0).

**Usage:** Setting only

**Manual operation:** See "[Scalar Power Cal – All Power Cals On / All Power Cals Off](#)" on page 422

---

**[SENSe<Ch>:]CORRection:POWer:DATA <Wave>, <CorrData>...**

Reads or writes receiver power correction data sets. A power correction data set contains *n* real values where:

- Each value corresponds to the ratio of the actual power at the receiver input (value provided by the used source) to the uncalibrated power in dB.
- The number *n* is equal to the number of sweep points.

Increasing (decreasing) the values in the correction data sets increases (decreases) the input power reading. Writing correction data (the setting command) fails if the number of transferred values is not equal to the number of sweep points.

**Suffix:**

<Ch>                      Calibrated channel number

**Parameters:**

<Wave>                    Identifier for the calibrated wave:  
'A<n>' or 'AWAV<n>' denote correction data for the reference wave *a*<*n*>, where <*n*> corresponds to the port number.  
'B<n>' or 'BWAV<n>' denote correction data for the reference wave *b*<*n*>.

<CorrData>                Power correction values either in ASCII or block data format, depending on the current [FORMat \[ :DATA\]](#) setting.

**Example:**

```
*RST; :SWE:POIN 10
```

Reset the instrument and reduce the number of sweep points to 10.

```
CORR:POW:ACQ AWAVE,1,PORT,1
```

Perform a receiver power calibration of the wave *a*<sub>1</sub> using port 1 as a source port, assuming that the transmitted source power *a*<sub>1</sub> is correct. No external cabling is needed.

```
CORR:POW:DATA? 'AWAV1'
```

Query the correction values. The analyzer returns 10 comma-separated real numbers.

```
CORR:POW:DATA 'AWAV1', 1, 2, 3, 4, 5, -6, -7, -8, -9, -0
```

Replace the correction values by ten (new) numbers.

**Manual operation:** See "[Start Cal Sweep](#)" on page 397

---

**[SENSe<Ch>:]CORRection:POWer<PhyPt>[:STATe] <Boolean>**

Enables or disables the receiver power calibration for channel <Ch> and for the received waves *b*<sub><PhyPt></sub>. The setting command is disabled unless the received waves have been power calibrated ([\[SENSe<Ch>:\]CORRection:POWer<PhyPt>:ACQuire](#) BWAVE, ...). The query always returns a result.

**Suffix:**

<Ch> Calibrated channel number

<PhyPt> Calibrated port number

**Parameters:**

<Boolean> Enables (ON) or disables (OFF) the receiver power calibration for the received waves  $b_{\langle\text{PhyPt}\rangle}$ .

\*RST: OFF

**Example:**

```
*RST; CORR:POW:ACQ BWAVE,1,PORT,2
```

Perform a receiver power calibration of the wave  $b_1$  using port 2 as a source port, assuming that the source power  $a_2$  is correct. A through connection from port 2 to port 1 is needed.

```
CORR:POW?
```

Check whether the calibration is applied (the response is 1).

```
CALC:PAR:MEAS 'TRC1', 'B1D2'
```

Select  $b_1$  as a measured quantity for the default trace.

```
CALC:MARK ON; MARK:Y?; :SOUR:POW?
```

Create marker no. <Mk> in the center of the sweep range and query the measurement value. The calibrated power of the received wave  $b_1$  is approx. equal to the default source power value.

See also example for [\[SENSe<Ch>:\]CORRection:POWer<PhyPt>:ACQuire](#).

**Manual operation:** See "[Port Overview](#)" on page 423

---

```
[SENSe<Ch>:]CORRection:POWer<PhyPt>:ACQuire <Wave>[, <CalPort>[,
<SourceType>[, <SourcePort>[, <CalOnlyPortFreq>]]]]
```

Selects the wave quantity and the source for the receiver power calibration, starts the calibration sweep, and applies the receiver power correction.

**Suffix:**

<Ch> Calibrated channel number

<PhyPt> This suffix is ignored because the port number is specified in the parameter list.

**Setting parameters:**

<Wave> AWAVE | BWAVE | B1 | B2 | B3 | B4

AWAVE – calibration of reference waves  $a_1, a_2, \dots$ . In manual control, the reference receiver calibration is included in the source power calibration of each port.

BWAVE – calibration of received wave  $b_1, b_2, \dots$ . The port number <CalPort>, the used <SourceType>, and the <SourcePort> number must be specified in addition.

Alternative: Parameters B1 and B2.

|                          |                                                                                                                                                                                                                                                                                                                                                                                                                                                                                                                                                                                                                                                                                                                                                                                                                                                 |
|--------------------------|-------------------------------------------------------------------------------------------------------------------------------------------------------------------------------------------------------------------------------------------------------------------------------------------------------------------------------------------------------------------------------------------------------------------------------------------------------------------------------------------------------------------------------------------------------------------------------------------------------------------------------------------------------------------------------------------------------------------------------------------------------------------------------------------------------------------------------------------------|
|                          | B1   B2 ... – direct wave and cal port setting for received waves $b_1, b_2 \dots$ . The parameters B1 and B2 are ZVR-compatible. No additional parameters must be specified. The source for B1 is port 2 and vice versa.                                                                                                                                                                                                                                                                                                                                                                                                                                                                                                                                                                                                                       |
| <CalPort>                | Calibrated port number<br>Range: 1 to port number of the analyzer                                                                                                                                                                                                                                                                                                                                                                                                                                                                                                                                                                                                                                                                                                                                                                               |
| <SourceType>             | PORT<br>PORT - internal source at port <CalPort>, to be fed to port <SourcePort> using an external through connection. If <CalPort> = <SourcePort>, an Open or Short standard is required.                                                                                                                                                                                                                                                                                                                                                                                                                                                                                                                                                                                                                                                      |
| <SourcePort>             | Number of the port for the internal source.                                                                                                                                                                                                                                                                                                                                                                                                                                                                                                                                                                                                                                                                                                                                                                                                     |
| <CalOnlyPortFreq>        | Relevant for frequency conversion measurements only.<br><b>OFF   0</b><br>The reference receiver at port <CalPort> is calibrated for all frequencies that are relevant for any of the ports.<br><b>ON   1</b><br>Only those frequencies are calibrated that are relevant for this port. This results in shorter calibration times.<br>*RST: 0                                                                                                                                                                                                                                                                                                                                                                                                                                                                                                   |
| <b>Example:</b>          | <pre>*RST; CORR:POW:ACQ AWAVE,1,PORT,1</pre> <p>Perform a receiver power calibration of the wave <math>a_1</math> using port 1 as a source port, assuming that the transmitted source power <math>a_1</math> is correct. No external cabling is needed.</p> <pre>CORR:POW:AWAV?</pre> <p>Check whether the calibration is applied (the response is 1).</p> <pre>CALC:PAR:MEAS 'TRC1', 'A1'</pre> <p>Select <math>a_1</math> as a measured quantity for the default trace.</p> <pre>CALC:MARK ON; MARK:Y?; :SOUR:POW?</pre> <p>Create marker no. &lt;Mk&gt; in the center of the sweep range and query the measurement value. The calibrated power of the reference wave <math>a_1</math> is approx. equal to the default source power value. See also example for <a href="#">[SENSe&lt;Ch&gt;:]CORRection:OFFSet&lt;PhyPt&gt;[:STATe]</a>.</p> |
| <b>Usage:</b>            | Setting only                                                                                                                                                                                                                                                                                                                                                                                                                                                                                                                                                                                                                                                                                                                                                                                                                                    |
| <b>Manual operation:</b> | See " <a href="#">Port Overview</a> " on page 394                                                                                                                                                                                                                                                                                                                                                                                                                                                                                                                                                                                                                                                                                                                                                                                               |

---

**[SENSe<Ch>:]CORRection:POWer<PhyPt>:AWAVE[:STATe] <Boolean>**

Enables or disables the receiver power calibration for channel <Ch> and for the reference waves  $a_n$ . The setting command is disabled unless the reference waves have been power calibrated ([\[SENSe<Ch>:\]CORRection:POWer<PhyPt>:ACQuire](#) on page 952 `AWAVE, . . .`). The query always returns a result.

This command extends the functionality of manual control, where the reference receiver calibration is included in the source power calibration of each port (and always ON).

**Suffix:**

<Ch>                      Calibrated channel number  
 <PhyPt>                    Calibrated port number

**Parameters:**

<Boolean>                Enables (ON) or disables (OFF) the receiver power calibration for the reference waves  $a_n$ .  
 \*RST:                    OFF

**Example:**                See `[SENSe<Ch>:]CORRection:POWer<PhyPt>:ACQuire`

**[SENSe<Ch>:]CORRection:STIMulus?**

Queries the stimulus values of the active calibration. A calibration must be selected before the command is executed; see example.

**Suffix:**

<Ch>                      Channel number of the calibrated channel

**Example:**

```
*RST; :CORR:COLL:METH:DEF 'Test',RShort,1
Select a one-port normalization at port 1 with a short standard
as calibration type.
CORR:STIM?
Query the stimulus frequencies. The response contains 201 fre-
quency values.
CORR:COLL:SEL SHOR,1
Measure a short standard connected to port 1 and store the
measurement results of this standard.
CORR:COLL:SAVE:SEL
Calculate the system error correction data and apply it to the
active channel.
```

**Usage:**                    Query only

**Manual operation:**    See "Apply" on page 392

**[SENSe<Ch>:]CORRection:COLLect:AUTO:ASSignment:ALL:COUNT?**

Returns the total number of port assignments of *all* calibrations.

See [Chapter 5.5.5.5, "Multiple Port Assignments"](#), on page 165 for background information.

**Note:**

Use `[SENSe<Ch>:]CORRection:COLLect:AUTO:ASSignment:COUNT?` to get the number of port assignments of the "current" calibration.

**Suffix:**

<Ch>                      Channel number

**Example:** See [Chapter 9.2.5.2, "MultiCal \(with Calibration Unit\)"](#), on page 1136

**Usage:** Query only

### [SENSe<Ch>:]CORRection:COLLect:AUTO:ASSignment:COUNT?

Returns the number of port assignments of the "current" calibration, i.e. the calibration last created using [\[SENSe<Ch>:\]CORRection:COLLect:AUTO:CONFigure](#).

This is particularly useful if the default port assignments were established using [\[SENSe<Ch>:\]CORRection:COLLect:AUTO:ASSignment:DEFine:DEFault](#). See [Chapter 5.5.5.5, "Multiple Port Assignments"](#), on page 165 for background information.

**Note:**

In MultiCal scenarios, use [\[SENSe<Ch>:\]CORRection:COLLect:AUTO:ASSignment:ALL:COUNT?](#) to get the number of port assignments of all calibrations.

**Suffix:**

<Ch> Channel number

**Example:** See [\[SENSe<Ch>:\]CORRection:COLLect:AUTO:ASSignment<Asg>:DEFine](#) on page 957

**Usage:** Query only

### [SENSe<Ch>:]CORRection:COLLect:AUTO:ASSignment:DEFine:DEFault <TestPort1>[, <TestPort2>]...

Creates the default port assignment(s) for the specified test ports.

The number of created assignments can be queried using the [\[SENSe<Ch>:\]CORRection:COLLect:AUTO:ASSignment:COUNT?](#) command.

**Note** that during the corresponding calibration sweep the R&S ZND expects the physical port connections to be established exactly as specified by the created port assignments.

**Use**

- [\[SENSe<Ch>:\]CORRection:COLLect:AUTO:ASSignment:DEFine:TPORT:DEFault](#) on page 956 to use auto-detection instead of defining "test port --> cal unit port"-connections explicitly
- [\[SENSe<Ch>:\]CORRection:COLLect:AUTO:ASSignment<Asg>:DEFine](#) or [\[SENSe<Ch>:\]CORRection:COLLect:AUTO:ASSignment<Asg>:DEFine:TPORT](#) to define (additional) port assignments manually

See [Chapter 5.5.5.5, "Multiple Port Assignments"](#), on page 165 for background information.

**Suffix:**

<Ch> Channel number

**Setting parameters:**

<TestPort1> Test port number 1

<TestPort2> Test port number 2

**Example:** See [\[SENSe<Ch>:\]CORRection:COLLect:AUTO:ASSignment<Asg>:DEFine](#) on page 957

**Usage:** Setting only

**[SENSe<Ch>:]CORRection:COLLect:AUTO:ASSignment:DEFine:TPORt:DEFault**  
<TestPort1>[, <TestPort2>]...

Similar logic as [\[SENSe<Ch>:\]CORRection:COLLect:AUTO:ASSignment:DEFine:DEFault](#), but initially defines the default port assignments only by their underlying test port set(s); the connected calibration unit ports are **auto-detected** at the start of the corresponding calibration sweep.

The number of created assignments can be queried using the [\[SENSe<Ch>:\]CORRection:COLLect:AUTO:ASSignment:COUNT?](#) command.

See [Chapter 5.5.5.5, "Multiple Port Assignments"](#), on page 165 for background information.

**Suffix:**

<Ch>

**Setting parameters:**

<TestPort1>

<TestPort2>

**Example:** See [\[SENSe<Ch>:\]CORRection:COLLect:AUTO:ASSignment<Asg>:DEFine](#) on page 957

**Usage:** Setting only

**[SENSe<Ch>:]CORRection:COLLect:AUTO:ASSignment:DELeTe:ALL**

Deletes all port assignments (see [Chapter 5.5.5.5, "Multiple Port Assignments"](#), on page 165).

**Suffix:**

<Ch> Channel number of the calibrated channel

**Example:** See [\[SENSe<Ch>:\]CORRection:COLLect:AUTO:ASSignment<Asg>:DEFine](#)

**Usage:** Event

**[SENSe<Ch>:]CORRection:COLLect:AUTO:ASSignment<Asg>:ACQuire**

Starts the automatic calibration sweep for the indicated channel and port assignment.



A complete, valid set of port assignments must be defined before you can initiate a calibration. See [Chapter 5.5.5.5, "Multiple Port Assignments"](#), on page 165 for background information.

**Suffix:**

<Ch>                      Number of the calibrated channel  
 <Asg>                     Number of the port assignment

**Example:**

See `[SENSe<Ch>:]CORRection:COLLect:AUTO:ASSignment<Asg>:DEFine`

**Usage:**

Event

**Manual operation:** See ["Start Cal Sweep / Abort Sweep"](#) on page 384

`[SENSe<Ch>:]CORRection:COLLect:AUTO:ASSignment<Asg>:DEFine`  
`<TestPort1>, <CalUnitPort1>[, <TestPort2>]...`

Manually defines port assignment no. <Asg> for channel no. <Ch>.

With manual configuration a non-minimal set of port assignments can be created, which may increase measurement accuracy. On the other hand, it is up to the user to ensure that the created set of port assignments is complete and valid for the chosen calibration type (see `[SENSe<Ch>:]CORRection:COLLect:AUTO:CONFigure`).

**Note** that during the corresponding calibration sweep the R&S ZND expects the physical port connections to be established exactly as defined by the port pairs.

**Use**

- `[SENSe<Ch>:]CORRection:COLLect:AUTO:ASSignment<Asg>:DEFine:TPORT` command to take advantage of auto-detection of port connections.
- `[SENSe<Ch>:]CORRection:COLLect:AUTO:ASSignment:DEFine:DEFAULT` or `[SENSe<Ch>:]CORRection:COLLect:AUTO:ASSignment:DEFine:TPORT:DEFAULT` to create the default assignments instead.

See [Chapter 5.5.5.5, "Multiple Port Assignments"](#), on page 165 for background information.

**Suffix:**

<Ch>                      Number of the channel  
 <Asg>                     Number of the port assignment

**Parameters:**

<TestPort1>              First test port number  
 <CalUnitPort1>          Number of the calibration unit port that is assigned to the first test port  
 <TestPort2>              Second test port number ...

**Example:**

Let's perform a full 3-port calibration with a two-port calibration unit, using factory characterization and the port assignments given in the table below.

Prerequisite: the adequate calibration unit was selected before using `SYSTem:COMMunicate:RDEvice:AKAL:ADDRESS`

```
SENSe1:CORRection:COLLect:AUTO:ASSignment:
DELeTe:ALL
```

Deletes all available port assignments.

```
SENSe1:CORRection:COLLect:AUTO:CONFigure
'FNPort', ''
```

Sets the automatic calibration to "Full n-port" with factory characterization.

```
SENSe1:CORRection:COLLect:AUTO:ASSignment1:
DEFine 2,1,3,2
```

Creates port assignment 1 explicitly (no auto-detection).

```
SENSe1:CORRection:COLLect:AUTO:ASSignment2:
DEFine:TPORT 3,4
```

Creates port assignment 2 implicitly (auto-detection).

Before starting the calibration sweep for port assignment 1, ensure test port 2 is connected to cal unit port 1 and test port 3 to cal unit port 2

```
SENSe1:CORRection:COLLect:AUTO:ASSignment1:
ACQUire
```

Performs the calibration sweep for port assignment 1

Before starting the calibration sweep for port assignment 2, ensure test ports 3 and 4 are connected to the cal unit (in any order)

```
SENSe1:CORRection:COLLect:AUTO:ASSignment2:
ACQUire
```

Performs the calibration sweep for port assignment 2; auto-detects the existing port-connections at runtime

```
SENSe1:CORRection:COLLect:AUTO:SAVE
```

Checks whether the acquired calibration data are sufficient to calculate the system error correction. If yes, applies them to the selected channel.

| Test Port | Port Assignment 1 | Port Assignment 2 |
|-----------|-------------------|-------------------|
| 2         | Cal Unit Port 1   | -                 |
| 3         | Cal Unit Port 2   | auto-detected     |
| 4         | -                 | auto-detected     |

```
[SENSe<Ch>:]CORRection:COLLect:AUTO:ASSignment<Asg>:DEFine:TPORT
<TestPort1>[, <TestPort2>]...
```

Similar logic as `[SENSe<Ch>:]CORRection:COLLect:AUTO:ASSignment<Asg>:DEFine`, but initially defines the port assignment only by its underlying test port set; the connected calibration unit ports are **auto-detected** at the start of the corresponding calibration sweep.

**Suffix:**  
 <Ch>                    Number of the channel  
 <Asg>                    Number of the port assignment

**Parameters:**  
 <TestPort1>            First test port number  
 <TestPort2>            Second test port number ...

**Example:**            See [\[SENSe<Ch>:\]CORRection:COLLect:AUTO:ASSignment<Asg>:DEFine](#) on page 957

### **[SENSe<Ch>:]CORRection:COLLect:AUTO:SAVE**

Calculates the system error correction for automatic calibrations with [Multiple Port Assignments](#), saves the data and applies the calibration to the active channel.

Requires successful calibration sweeps for all related port assignments (see [\[SENSe<Ch>:\]CORRection:COLLect:AUTO:ASSignment<Asg>:ACquire](#))

**Suffix:**  
 <Ch>                    Channel number of the calibrated channel

**Example:**            See [\[SENSe<Ch>:\]CORRection:COLLect:AUTO:ASSignment<Asg>:DEFine](#)

**Usage:**                Event

**Manual operation:** See ["Apply/Cancel"](#) on page 384

### **[SENSe<Chn>:]CORRection:PState?**

Gets the power calibration label of the active trace in channel <Chn>.

See [Chapter 5.5.6.3, "Power Calibration Labels"](#), on page 170 for the possible return values.

**Suffix:**  
 <Chn>                    Channel number used to identify the active trace

**Usage:**                Query only

**Manual operation:** See ["Apply"](#) on page 394

### **[SENSe<Chn>:]CORRection:SState?**

Returns the system error correction state label of the active trace in channel <Chn>. The response is a string variable containing the calibration state label in the trace list ('CAL', 'CAI', 'CAL OFF' ..; see [Chapter 5.5.4, "Calibration Labels"](#), on page 158).

**Suffix:**  
 <Chn>                    Channel number used to identify the active trace

**Example:**            See [\[SENSe<Ch>:\]CORRection:DATE?](#)

**Usage:** Query only  
**Manual operation:** See ["Apply"](#) on page 392

### 8.3.14.9 [SENSe:]COUPle...

The [SENSe:]COUPle... commands select the sweep mode.

---

**[SENSe<Ch>:]COUPle <Mode>[, <NumAltBlocks>]**

Determines the order of partial measurements and sweeps (see [Chapter 5.1.4.1, "Partial Measurements and Driving Mode"](#), on page 73).

**Suffix:**

<Ch> Channel number. This suffix is ignored; the sweep mode applies to all channels in the active recall set.

**Parameters:**

<Mode> ALL | AUTO | NONE | BLOCK  
 AUTO – automatic mode: fast sweeps are performed in alternated driving mode, slower sweeps in chopped mode  
 ALL – chopped driving mode, complete all partial measurements before proceeding to the next sweep point  
 NONE – alternated driving mode on, reverse the order of partial measurements and sweeps  
 BLOCK – block alternated driving mode  
 \*RST: NONE

<NumAltBlocks> Defines the number of blocks for the "Block Alternated" driving mode.  
 \*RST: 3

**Example:**

COUP NONE

Activate the alternated driving mode.

TRIG:LINK 'PPO'

Set the triggered measurement sequence equal to one partial measurement. Each trigger event starts one partial measurement for all sweep points.

**Manual operation:** See ["Driving Mode"](#) on page 433

### 8.3.14.10 [SENSe:]FREQuency...

The [SENSe:]... commands set frequency-related parameters, especially the measurement and display ranges for the different sweep types. The frequency ranges for the different instrument models are listed below; for more details refer to the data sheet.

Table 8-15: Frequency ranges of R&amp;S ZND analyzers

| Frequency settings | R&S ZND (with frequency range extension) |
|--------------------|------------------------------------------|
| Start, Stop        | 9 kHz to 4.5 GHz (8.5 GHz)               |
| Center             | >9 kHz to <4.5 GHz (8.5 GHz)             |
| Span               | 1 Hz to 4.499991 GHz (8.499991 GHz)      |

|                                         |     |
|-----------------------------------------|-----|
| [SENSe<Ch>:]FREQUency[:CW].....         | 961 |
| [SENSe<Ch>:]FREQUency:FIXed.....        | 961 |
| [SENSe<Ch>:]FREQUency:CENTer.....       | 961 |
| [SENSe<Ch>:]FREQUency:SEGMENT:AXIS..... | 962 |
| [SENSe<Ch>:]FREQUency:SPAN.....         | 962 |
| [SENSe<Ch>:]FREQUency:START.....        | 963 |
| [SENSe<Ch>:]FREQUency:STOP.....         | 963 |

**[SENSe<Ch>:]FREQUency[:CW] <FixedFreq>**

**[SENSe<Ch>:]FREQUency:FIXed <FixedFreq>**

Defines the fixed (Continuous Wave, CW) frequency for all sweep types operating at fixed frequency ("Power", "Time", "CW Mode"). The two command forms [SENSe<Ch>:]FREQUency[:CW] and [SENSe<Ch>:]FREQUency:FIXed are equivalent.

The frequency ranges are listed in [Table 8-15](#).

**Note:** [SENSe<Ch>:]FREQUency[:CW] | :FIXed is equivalent to SOURce<Ch>:FREQUency<PhyPt>[:CW] | :FIXed. Source and receiver frequency are always equal; the four commands overwrite each other.

**Suffix:**

<Ch> Channel number

**Parameters:**

<FixedFreq> Fixed stimulus and analyzer frequency  
 \*RST: 1 GHz  
 Default unit: Hz

**Example:**

```
FUNC "XTIME:POW:A1"
```

Activate a time sweep and select the wave quantity  $a_1$  as measured parameter for channel and trace no. 1.

```
FREQ: CW 100MHz
```

Set the CW frequency to 100 MHz.

**Manual operation:** See "[CW Frequency](#)" on page 346

**[SENSe<Ch>:]FREQUency:CENTer <CenterFreq>**

Defines the center of the measurement and display range for a frequency sweep (sweep range). The default center frequency is the center of the analyzer's maximum frequency range:  $(f_{\text{MIN}} + f_{\text{MAX}})/2$ . The range is listed in [table Table 8-15](#).

**Suffix:**

<Ch> Channel number

**Parameters:**

<CenterFreq> Center frequency of the sweep  
Increment: 0.1 kHz  
Default unit: Hz

**Example:**

```
*RST; :SYST:FREQ? MIN; :SYST:FREQ? MAX
Query the frequency range of the analyzer.
FREQ:CENT 100MHZ
Set center frequency to 100 MHz.
FREQ:SPAN 50000
Set frequency span to 50 kHz.
```

**Manual operation:** See ["Start Frequency / Stop Frequency / Center Frequency / Span Frequency"](#) on page 346

**Note:** The measurement range defined by means of the center frequency and the current span (`[SENSe<Ch>:]FREQuency:SPAN`) must not exceed the allowed frequency range of the analyzer. If necessary, the span is reduced to  $\min(\text{<CenterFreq>} - f_{\text{MIN}}, f_{\text{MAX}} - \text{<CenterFreq>})$ .

**[SENSe<Ch>:]FREQuency:SEGMENT:AXIS <Scale>**

Selects either frequency based or point based x-axis for segmented sweeps.

**Suffix:**

<Ch> Channel number

**Parameters:**

<Scale> POINT | FREQuency

**Example:**

```
SENSe:SEGMENT:INSert 1MHZ, 1.1MHZ, 101, -21DBM,
0.5S, 0, 10KHZ
SENSe:SEGMENT:INSert 2MHZ, 3MHZ, 101, -21DBM,
0.5S, 0, 10KHZ
Create two sweep segments with different frequency spans,
each with 101 sweep points.
SENSe:SEGMENT:FREQuency:AXIS POINT
Select the point based frequency axis. The first 101 sweep
points are distributed over the left half of the diagram, the sec-
ond 101 points over the right half.
```

**Manual operation:** See ["Seg X-Axis"](#) on page 359

**[SENSe<Ch>:]FREQuency:SPAN <Span>**

Defines the width (span) of the measurement and display range for a frequency sweep (sweep range). The default span equals to the maximum frequency range of the analyzer:  $f_{\text{MAX}} - f_{\text{MIN}}$ .

The range is listed in [Table 8-15](#).

**Suffix:**

<Ch> Channel number

**Parameters:**

<Span> Frequency span of the sweep  
Increment: 0.1 kHz  
Default unit: Hz

**Example:**

See `[SENSe<Ch>:]FREQuency:CENTer`

**Manual operation:** See "Start Frequency / Stop Frequency / Center Frequency / Span Frequency" on page 346

**Note:** The measurement range defined by means of the span and the current center frequency (`[SENSe<Ch>:]FREQuency:CENTer`), must not exceed the allowed frequency range of the analyzer. If necessary, the center frequency is adjusted to  $f_{\text{MIN}} + \text{<Span>/2}$  or  $f_{\text{MAX}} - \text{<Span>/2}$ .

`[SENSe<Ch>:]FREQuency:START <StartFreq>`

`[SENSe<Ch>:]FREQuency:STOP <StopFreq>`

These commands defines the start and stop frequency for a frequency sweep. The values also define the display range in a Cartesian diagram. The default start and stop frequencies equal to the minimum and maximum frequency of the analyzer.

The ranges are listed in [Table 8-15](#).

**Suffix:**

<Ch> Channel number

**Parameters:**

<StopFreq> Start and stop frequency of the sweep  
Increment: 0.1 kHz  
Default unit: Hz

**Example:**

`*RST; FREQ:STAR 100000`

Activate a frequency sweep and set the start frequency to 100 kHz.

`FREQ:STOP 10MHz`

Set the stop frequency to 10 MHz.

**Manual operation:** See "Start Frequency / Stop Frequency / Center Frequency / Span Frequency" on page 346

**Note:** If the start frequency entered is greater than the current stop frequency, the stop frequency is set to the start frequency plus the minimum frequency span (`[SENSe<Ch>:]FREQuency:SPAN`).

If the stop frequency entered is smaller than the current start frequency, the start frequency is set to the stop frequency minus the minimum frequency span.

**8.3.14.11 [SENSe:]HARMonic...**

Implements functions related to harmonic grids for time domain transformation.

|                           |     |
|---------------------------|-----|
| [SENSe<Ch>:]HARMonic?     | 964 |
| [SENSe<Ch>:]HARMonic:AUTO | 964 |

**[SENSe<Ch>:]HARMonic?**

Queries whether the current frequency grid is harmonic.

**Suffix:**

<Ch> Channel number

**Return values:**

<arg0>

**Usage:** Query only

**Manual operation:** See "[Is the Current Grid Harmonic?](#)" on page 282

**[SENSe<Ch>:]HARMonic:AUTO <arg0>**

Turns the "Automatic Harmonic Grid" function ON or OFF.

**Suffix:**

<Ch> Channel number

**Parameters:**

<arg0> \*RST: ON

**Options:** R&S ZND-K2

**Manual operation:** See "[Automatic Harmonic Grid](#)" on page 283

**8.3.14.12 [SENSe:]LPORt...**

The [SENSe:]LPORt... commands define the reference impedances of the balanced ports.

|                                           |     |
|-------------------------------------------|-----|
| [SENSe<Ch>:]LPORt<LogPt>:ZCOMmon          | 964 |
| [SENSe<Ch>:]LPORt<LogPt>:ZDIFferent       | 964 |
| [SENSe<Ch>:]LPORt<LogPt>:ZDEFault[:STATE] | 965 |

**[SENSe<Ch>:]LPORt<LogPt>:ZCOMmon <RealPart>[, <ImaginaryPart>]**

**[SENSe<Ch>:]LPORt<LogPt>:ZDIFferent <RealPart>[, <ImaginaryPart>]**

These commands specify the complex common mode and differential mode reference impedances for the balanced (logical) port numbered <LogPt>.

Use [SENSe<Ch>:]LPORt<LogPt>:ZDEFault[:STATE] to toggle between configured and default reference impedances.



**Note:** For a unidirectional R&S ZND (see [Chapter 5.1.4.3, "R&S ZND: Unidirectional vs. Bidirectional Operation"](#), on page 75) balanced ports are not supported and hence these commands are not available.

**Suffix:**

<Ch> Channel number

<LogPt> Logical port number. The logical ports must be defined using `SOURce<Ch>:LPORt<LogPt> <PhysicalPort1>, <PhysicalPort2>`. An n port analyzer supports a maximum of  $n/2$  (n even) or  $(n - 1)/2$  (n odd) logical ports.

**Parameters:**

<RealPart> Real part of the port impedance.  
 Range: 1 mΩ to 10 MΩ  
 \*RST: ZCOMmon: 25 Ω; ZDIFferent: 100 Ω (real impedances)  
 Default unit: Ohm

<ImaginaryPart> Imaginary part of the port impedance; may be omitted to define a real impedance.  
 Range: - 10 MΩ to 10 MΩ  
 \*RST: 0 Ω (real impedances)  
 Default unit: Ohm

**Example:**

```
*RST; :CALC:PAR:DEL 'TRC1'
```

Reset the analyzer and delete the (default) trace for channel no. 1.

```
SOUR:LPOR1 1,2
```

Combine the physical ports no. 1 and 2 to define the balanced (logical) port no. 1.

```
LPOR1:ZDIF 27, 2
```

Specify a complex differential mode reference impedance of  $27\Omega + j * 2\Omega$  for the defined port.

**Manual operation:** See "[Single Ended Mode / Common Mode / Differential Mode](#)" on page 230

---

**[SENSe<Ch>:]LPORt<LogPt>:ZDEFault[:STATE] <arg0>**

Allows to toggle between default and renormalized reference impedance(s) for logical port <LogPt>.

**Suffix:**

<Ch> Channel number

<LogPt> Logical port number

**Parameters:**

<arg0> ON (1): Use default impedance(s)  
 OFF (0): Use the redefined impedances defined via  
[\[SENSe<Ch>:\]PORT<PhyPt>:ZREference](#) for single-ended  
 or via [\[SENSe<Ch>:\]LPORT<LogPt>:ZCOMmon](#) and  
[\[SENSe<Ch>:\]LPORT<LogPt>:ZDIfferent](#) for balanced  
 logical ports

**Manual operation:** See ["Use Default"](#) on page 230

**8.3.14.13 [SENSe:]PORT...**

The [\[SENSe:\]PORT...](#) commands define the reference impedances at the physical ports.

---

**[SENSe<Ch>:]PORT<PhyPt>:ZREference <RealPart>[, <ImaginaryPart>]**

Specifies the complex reference impedance for the physical port numbered <PhyPt> (impedance renormalization).

Use [\[SENSe<Ch>:\]LPORT<LogPt>:ZDEfault\[:STATe\]](#) to toggle between configured and default reference impedances.

**Suffix:**

<Ch> Channel number  
 <PhyPt> Physical port number

**Parameters:**

<RealPart> Real part of the port impedance.  
 Range: 1 mΩ to 10 MΩ  
 \*RST: Default reference impedance of the connector family assigned to the port (real impedance, e.g. 50 Ω).  
 Default unit: Ohm

<ImaginaryPart> Imaginary part of the port impedance. This part may be omitted to define a real impedance.  
 Range: - 10 MΩ to 10 MΩ  
 \*RST: Default reference impedance of the connector family assigned to the port (real impedance, e.g. 50 Ω).  
 Default unit: Ohm

**Example:**

```
PORT2:ZREF 52, 2
```

Specify a complex reference impedance of 52 Ω + j \* 2 Ω for the (physical) port no. 2.

```
CALC:TRAN:IMP:RNOR PWAV
```

Select renormalization of port impedances according to the power waves theory.

**Manual operation:** See ["Single Ended Mode / Common Mode / Differential Mode"](#) on page 230

**8.3.14.14 [SENSe:]ROSCillator...**

The [SENSe:]ROSCillator... commands control the frequency reference signal.

---

**[SENSe<Ch>:]ROSCillator[:SOURce] <Source>**

Selects the source of the reference oscillator signal.

**Parameters:**

<Source>            INTernal | EXTernal  
 INTernal – internal 10 MHz reference oscillator  
 EXTernal – external reference clock  
 The frequency of the external reference clock can be defined using [SENSe:]ROSCillator:EXTernal:FREQUENCY  
 \*RST:            INTernal

**Example:**            See [SENSe:]ROSCillator:EXTernal:FREQUENCY on page 967.

**Manual operation:**    See "Internal/External" on page 538

---

**[SENSe:]ROSCillator:EXTernal:FREQUENCY <ExtClockFreq>**

Specifies or queries the frequency of the external reference oscillator.

**Parameters:**

<ExtClockFreq>      Frequency of the external reference clock signal.  
 Range:            See the data sheet of your analyzer.  
 \*RST:            10 MHz  
 Default unit: Hz

**Example:**            ROSC EXT  
 Select the external reference clock as clock source.  
 ROSC:EXT:FREQ 10MHz  
 Specify the frequency of the external reference clock.  
 ROSC:EXT:FREQ?  
 Query the frequency of the external reference oscillator. The response is 10000000 Hz.

**Manual operation:**    See "Ext Frequency" on page 539

**8.3.14.15 [SENSe:]SEGMent<Seg>...**

The [SENSe:]SEGMent<Seg>... commands define all channel settings for a segmented frequency sweep. A segmented sweep is activated via [SENSe<Ch>:]SWEep:TYPE SEGMent.



The commands in this subsystem do not accept the step parameters UP and DOWN. Numeric values can be entered directly or using the DEFault, MINimum, MAXimum parameters.

|                                                           |     |
|-----------------------------------------------------------|-----|
| [SENSe<Ch>:]SEGMENT:COUNT?.....                           | 968 |
| [SENSe<Ch>:]SEGMENT<Seg>[:STATe].....                     | 968 |
| [SENSe<Ch>:]SEGMENT<Seg>:ADD.....                         | 969 |
| [SENSe<Ch>:]SEGMENT<Seg>:BWIDTh[:RESolution].....         | 969 |
| [SENSe<Ch>:]SEGMENT<Seg>:BWIDTh[:RESolution]:CONTRol..... | 970 |
| [SENSe<Ch>:]SEGMENT<Seg>:DEFine.....                      | 971 |
| [SENSe<Ch>:]SEGMENT<Seg>:DEFine:SELect.....               | 972 |
| [SENSe<Ch>:]SEGMENT<Seg>:DELeTe:ALL.....                  | 973 |
| [SENSe<Ch>:]SEGMENT<Seg>:DELeTe[:DUMMy].....              | 973 |
| [SENSe<Ch>:]SEGMENT<Seg>:FREQUency:CENTer?.....           | 974 |
| [SENSe<Ch>:]SEGMENT<Seg>:FREQUency:SPAN?.....             | 974 |
| [SENSe<Ch>:]SEGMENT<Seg>:FREQUency:STARt.....             | 974 |
| [SENSe<Ch>:]SEGMENT<Seg>:FREQUency:STOP.....              | 974 |
| [SENSe<Ch>:]SEGMENT<Seg>:INSert.....                      | 975 |
| [SENSe<Ch>:]SEGMENT<Seg>:INSert:SELect.....               | 977 |
| [SENSe<Ch>:]SEGMENT<Seg>:POWer[:LEVel].....               | 977 |
| [SENSe<Ch>:]SEGMENT<Seg>:POWer[:LEVel]:CONTRol.....       | 978 |
| [SENSe<Ch>:]SEGMENT<Seg>:SWEep:DWELL.....                 | 978 |
| [SENSe<Ch>:]SEGMENT<Seg>:SWEep:DWELL:CONTRol.....         | 979 |
| [SENSe<Ch>:]SEGMENT<Seg>:SWEep:POINts.....                | 980 |
| [SENSe<Ch>:]SEGMENT<Seg>:SWEep:TIME.....                  | 980 |
| [SENSe<Ch>:]SEGMENT<Seg>:SWEep:TIME:CONTRol.....          | 981 |
| [SENSe<Ch>:]SEGMENT<Seg>:SWEep:TIME:SUM?.....             | 982 |

---

### [SENSe<Ch>:]SEGMENT:COUNT?

Returns the number of sweep segments in the channel including all segments that are switched off ([SENSe<Ch>:]SEGMENT<Seg>[:STATe] OFF).

**Suffix:**

<Ch> Channel number

**Example:**

```
SEGM:ADD
```

Create a new sweep segment no. 1 in channel no. 1 using default settings.

```
SEGM OFF
```

Disable the measurement in the created sweep segment.

```
SEGM:COUN?
```

Query the number of segments.

**Usage:**

Query only

**Manual operation:** See "Table Columns" on page 361

---

### [SENSe<Ch>:]SEGMENT<Seg>[:STATe] <Boolean>

Activates or deactivates the sweep segment <Seg>. Sweep points belonging to inactive segments only are not measured.

**Suffix:**

<Ch> Channel number

|                          |                                                                                                                                                                                       |
|--------------------------|---------------------------------------------------------------------------------------------------------------------------------------------------------------------------------------|
| <Seg>                    | Sweep segment number                                                                                                                                                                  |
| <b>Parameters:</b>       |                                                                                                                                                                                       |
| <Boolean>                | ON   OFF - activates or deactivates the measurement in sweep segment <Seg>.                                                                                                           |
|                          | *RST: ON                                                                                                                                                                              |
| <b>Example:</b>          | <pre>SEGM:ADD</pre> <p>Create a new sweep segment no. 1 in channel no. 1 using default settings.</p> <pre>SEGM OFF</pre> <p>Disable the measurement in the created sweep segment.</p> |
| <b>Manual operation:</b> | See <a href="#">"Table Columns"</a> on page 361                                                                                                                                       |

---

### [SENSe<Ch>:]SEGMENT<Seg>:ADD

Inserts a new sweep segment using default channel settings ("Insert New Segment"). The added segment covers the frequency interval between the maximum frequency of the existing sweep segments and the stop frequency of the entire sweep range.

**Tip:** Use `[SENSe<Ch>:]SEGMENT<Seg>:INSert` to create a segment with specific channel settings.

#### Suffix:

|       |                                                                                                                                            |
|-------|--------------------------------------------------------------------------------------------------------------------------------------------|
| <Ch>  | Channel number                                                                                                                             |
| <Seg> | Sweep segment number. Segment numbers must be sequential. If n segments exist already, the added segment must have the segment number n+1. |

|                 |                                                                                                                                                                                                                                                                                                                     |
|-----------------|---------------------------------------------------------------------------------------------------------------------------------------------------------------------------------------------------------------------------------------------------------------------------------------------------------------------|
| <b>Example:</b> | <pre>SEGM:INS 1MHZ, 1.5MHZ, 111, -21DBM, 0.5S, 0, 10KHZ</pre> <p>Create a sweep segment with a sweep range between 1.0 MHz and 1.5 MHz.</p> <pre>SEGM2:ADD</pre> <p>Create a second sweep segment. The frequency range of the second segment will be between 1.5 MHz and the maximum frequency of the analyzer.</p> |
|-----------------|---------------------------------------------------------------------------------------------------------------------------------------------------------------------------------------------------------------------------------------------------------------------------------------------------------------------|

**Usage:** Event

**Manual operation:** See ["Add / Insert / Delete / Delete All"](#) on page 362

---

### [SENSe<Ch>:]SEGMENT<Seg>:BWIDth[:RESolution] <ResBandwidth>

Defines the IF bandwidth of the analyzer (measurement bandwidth). Values between 1 Hz and 300 kHz can be set.

Bandwidths can be set in 1 – 1.5 – 2 – 3 – 5 – 7 steps. The analyzer rounds up any entered value between these steps and rounds down values exceeding the maximum bandwidth.

At the same time, the command activates separate bandwidth setting in all sweep segments (`[SENSe<Ch>:]SEGMENT<Seg>:BWIDth[:RESolution]:CONTrol ON`).

**Suffix:**

<Ch> Channel number  
 <Seg> Sweep segment number

**Parameters:**

<ResBandwidth> IF bandwidth  
 Range: See above  
 Increment: 1-1.5-2-3-5-7 steps  
 \*RST: 10 kHz  
 Default unit: Hz

**Example:** See `[SENSe<Ch>:]SEGMENT<Seg>:BWIDth[:RESolution]:CONTrol`

**Manual operation:** See "Optional Columns" on page 364

**[SENSe<Ch>:]SEGMENT<Seg>:BWIDth[:RESolution]:CONTrol <Boolean>**

Selects common or independent "Meas. Bandwidth" settings for the sweep segments.

**Suffix:**

<Ch> Channel number  
 <Seg> Sweep segment number. This suffix is ignored; the setting controls the whole segmented sweep.

**Parameters:**

<Boolean> ON – use independent bandwidth settings, to be defined via `[SENSe<Ch>:]SEGMENT<Seg>:BWIDth[:RESolution]`.  
 OFF – reset the bandwidth in all sweep segments to the bandwidth for unsegmented sweeps, defined via `[SENSe<Ch>:]BWIDth[:RESolution]`. ON will not restore the previous values.  
 The parameter is automatically switched to ON when a bandwidth is entered using `[SENSe<Ch>:]SEGMENT<Seg>:BWIDth[:RESolution]`.  
 \*RST: OFF

**Example:** \*RST; :SENS:SEGM:ADD  
 Create a new sweep segment no. 1 in channel no. 1 using default settings and thus 10 kHz measurement bandwidth.  
`SEGM:BWID 1 MHZ`  
 Increase the IF bandwidth to 1 MHz.  
`SEGM:BWID:CONT OFF`  
 Couple the bandwidths in all segments and reset the bandwidth in segment no. 1 to the initial value.

**Manual operation:** See "Optional Columns" on page 364

**[SENSe<Ch>:]SEGMENT<Seg>:DEFine** <StartFreq>, <StopFreq>, <Points>, <Power>, <SegmentTime>|<MeasDelay>, <Unused>, <MeasBandwidth>[, <LO>, <Selectivity>, <FreqSweepMode>]

Creates or re-defines a sweep segment no. <Seg> with specific channel settings.

Entry of the first seven numeric parameters is mandatory; no default values are provided. All settings except <LO> can be changed for existing segments using other commands of the [SENSe<Ch>:]SEGMENT<Seg>... subsystem.

**Note:** Use [SENSe<Ch>:]SEGMENT<Seg>:ADD to create a segment with default channel settings. Use [SENSe<Ch>:]SEGMENT<Seg>:INSert (no query) to insert a new segment into the current segment list.

**Suffix:**

<Ch> Channel number

<Seg> Sweep segment number. Segment numbers must be sequential. The specified segment number must be smaller or equal to the number of existing segments plus 1. If segment number <Seg> already exists, it is replaced by the new segment.

**Parameters:**

<StartFreq> Start frequency of the segment; see [SENSe<Ch>:]SEGMENT<Seg>:FREQUENCY:START.  
Default unit: Hz

<StopFreq> Stop frequency of the segment; see [SENSe<Ch>:]SEGMENT<Seg>:FREQUENCY:STOP.  
Default unit: Hz

<Points> Number of sweep points in the segment. See [SENSe<Ch>:]SEGMENT<Seg>:SWEep:POINTs.

<Power> Internal source power in the segment. See [SENSe<Ch>:]SEGMENT<Seg>:POWER[:LEVEL].  
Default unit: dBm

<SegmentTime> Duration of the sweep in the segment. See [SENSe<Ch>:]SEGMENT<Seg>:SWEep:TIME. In the setting [SENSe<Ch>:]SEGMENT<Seg>:INSert:SElect DWELL, this parameter is replaced by <MeasDelay>.  
Range: Depending on other channel settings. AUTO activates automatic sweep time setting in the segment, which is equivalent to the minimum sweep time possible.  
Default unit: s

<MeasDelay> Delay for each partial measurement in the segment. See [SENSe<Ch>:]SEGMENT<Seg>:SWEep:DWELL. In the setting [SENSe<Ch>:]SEGMENT<Seg>:INSert:SElect SWTime, this parameter is replaced by <SegmentTime>.

|                 |                                                                                                                                                                                                                 |
|-----------------|-----------------------------------------------------------------------------------------------------------------------------------------------------------------------------------------------------------------|
| <Unused>        | Ignored parameter (for compatibility with R&S ZVR analyzers). Should be set to the default value 0.                                                                                                             |
| <MeasBandwidth> | IF bandwidth in the segment. See [SENSe<Ch>: ]SEGMENT<Seg>:BWIDTh[:RESolution].<br>Default unit: Hz                                                                                                             |
| <LO>            | POSitive   NEGative   AUTO<br>Position of the local oscillator frequency LO relative to the RF frequency. In remote control this parameter must be set when a sweep segment is created.<br>Must be set to AUTO. |
| <Selectivity>   | NORMal<br>Selectivity of the IF filter; must be set to NORMal.                                                                                                                                                  |
| <Mode>          | AUTO<br>Ignored.                                                                                                                                                                                                |
| <FreqSweepMode> | STEPped<br>Frequency sweep mode; must be set to Stepped.                                                                                                                                                        |

**Example:**

```
SEGM:ADD
Create a new sweep segment no. 1 in channel no. 1 using
default settings.
SEGM:DEF?
Query the channel settings for the new segment. A possible
response is
1000000000,2000000000,51,-300,0.0044625,0,
10000,AUTO,NORM,STEP.
```

**Manual operation:** See "Optional Columns" on page 364

---

#### [SENSe<Ch>:]SEGMENT<Seg>:DEFine:SElect <TimeRef>

Defines whether the sweep time of a new segment, i.e. numeric parameter no. 5 of the command [SENSe<Ch>:]SEGMENT<Seg>:DEFine, is entered as a segment sweep time ("Segment Time") or as a measurement delay ("Meas Delay").

**Suffix:**

|       |                      |
|-------|----------------------|
| <Ch>  | Channel number       |
| <Seg> | Sweep segment number |

**Parameters:**

|           |                                                                                      |
|-----------|--------------------------------------------------------------------------------------|
| <TimeRef> | SWTime   DWELI<br>SWTime - use segment sweep time.<br>DWELI - use measurement delay. |
|-----------|--------------------------------------------------------------------------------------|



**Example:** `SEGM1:DEF:SEL DWEL`  
 Select the measurement delay to determine the sweep time in a new sweep segment no. 1.  
`SEGM1:DEF 1MHZ, 1.5MHZ, 111, -21DBM, 0.01S, 0, 10KHZ`  
 Create a sweep segment with a sweep range between 1.0 MHz and 1.5 MHz and a measurement delay of 10 ms.  
`SEGM1:SWE:TIME?`  
 Query the sweep time in the new segment.

**Manual operation:** See ["Optional Columns"](#) on page 364

### **[SENSe<Ch>:]SEGMENT<Seg>:DELEte:ALL**

Deletes all sweep segments in the channel. `[SENSe<Ch>:]SEGMENT<Seg>:DELEte[:DUMMy]` deletes a single segment.

**Suffix:**

<Ch> Channel number  
 <Seg> Sweep segment number. This suffix is ignored; the command deletes all segments.

**Example:** `SEGM:ADD`  
 Create a new sweep segment no. 1 in channel no. 1 using default settings.  
`SEGM:DEL:ALL`  
 Delete the created segment and all segments in the channel created before.

**Usage:** Event

**Manual operation:** See ["Add / Insert / Delete / Delete All"](#) on page 362

### **[SENSe<Ch>:]SEGMENT<Seg>:DELEte[:DUMMy]**

Deletes the specified (single) sweep segment. `[SENSe<Ch>:]SEGMENT<Seg>:DELEte:ALL` deletes all segments in the channel.

**Suffix:**

<Ch> Channel number  
 <Seg> Sweep segment number

**Example:** `SEGM:ADD`  
 Create a new sweep segment no. 1 in channel no. 1 using default settings.  
`SEGM:DEL`  
 Delete the created segment.

**Manual operation:** See ["Add / Insert / Delete / Delete All"](#) on page 362

---

**[SENSe<Ch>:]SEGMent<Seg>:FREQUency:CENTer?**  
**[SENSe<Ch>:]SEGMent<Seg>:FREQUency:SPAN?**

These commands return the center frequency and the span (width) of sweep segment no. <Seg>.

**Suffix:**

<Ch> Channel number  
 <Seg> Sweep segment number

**Example:**

```
SEGM:INS 1MHZ, 1.5MHZ, 111, -21DBM, 0.5S, 0,
10KHZ
```

Create a sweep segment with a sweep range between 1.0 MHz and 1.5 MHz.

```
SEGM:FREQ:CENT? SPAN?
```

Query the center frequency and span of the created segment.

The response is 1250000;500000.

**Usage:** Query only

**Manual operation:** See "Table Columns" on page 361

**Note:** The frequency range of the sweep segment can be changed via [\[SENSe<Ch>:\]SEGMent<Seg>:FREQUency:START](#) and [\[SENSe<Ch>:\]SEGMent<Seg>:FREQUency:STOP](#).

---

**[SENSe<Ch>:]SEGMent<Seg>:FREQUency:START <StartFreq>**  
**[SENSe<Ch>:]SEGMent<Seg>:FREQUency:STOP <StopFreq>**

These commands define the start and stop frequency of sweep segment no. <Seg>.

The sweep segments must be within the frequency range of the R&S ZND; see [Table 8-15](#).

**Suffix:**

<Ch> Channel number  
 <Seg> Sweep segment number

**Parameters:**

<StopFreq> Start or stop frequency of the sweep.  
 Increment: 0.1 kHz  
 Default unit: Hz

**Example:**

```
SEGM:INS 1MHZ, 1.5MHZ, 111, -21DBM, 0.5S, 0,
10KHZ
```

Create a sweep segment with a sweep range between 1.0 MHz and 1.5 MHz.

```
SEGM:FREQ:STAR?; STOP?
```

Query the start and stop frequency of the created segment. The response is 1000000;1500000.

**Manual operation:** See "Table Columns" on page 361

**Note:** If the start frequency entered is greater than the current stop frequency, the stop frequency is set to the start frequency. If the stop frequency entered is smaller than the current start frequency, the start frequency is set to the stop frequency.

---

**[SENSe<Ch>:]SEGMENT<Seg>:INSert** <StartFreq>, <StopFreq>, <Points>, <Power>, <SegmentTime>|<MeasDelay>, <Unused>, <MeasBandwidth>[, <LO>, <Selectivity>, <Mode>, <FreqSweepMode>]

Adds a new sweep segment no. <Seg> with specific channel settings.

Entry of the first seven numeric parameters is mandatory; no default values are provided. All settings except <LO> can be changed for existing segments using other commands of the [SENSe<Ch>:]SEGMENT<Seg>... subsystem.

**Note:** Use [SENSe<Ch>:]SEGMENT<Seg>:ADD to create a segment with default channel settings. Use [SENSe<Ch>:]SEGMENT<Seg>:DEFine to change or query all settings of an existing segment.

**Suffix:**

<Ch> Channel number

<Seg> Sweep segment number. Segment numbers must be sequential. The specified segment number must be smaller or equal to the number of existing segments plus 1. If one or more sweep segments with segment numbers <Seg> or larger exist in the current channel, then all these existing segment numbers are incremented by 1 and the new segment is inserted as segment no. <Seg>. Note that <Seg> defaults to 1, so [SENSe<Ch>:]SEGMENT:INSert inserts a new segment 1, shifting the existing segments one position up.

**Parameters:**

<StartFreq> Start frequency of the segment. See [SENSe<Ch>:]SEGMENT<Seg>:FREQUENCY:START.  
Default unit: Hz

<StopFreq> Stop frequency of the segment; see [SENSe<Ch>:]SEGMENT<Seg>:FREQUENCY:STOP.  
Default unit: Hz

<Points> Number of sweep points in the segment. See [SENSe<Ch>:]SEGMENT<Seg>:SWEep:POINTs.

<Power> Internal source power in the segment. See [SENSe<Ch>:]SEGMENT<Seg>:POWER[:LEVel].  
Default unit: dBm

|                          |                                                                                                                                                                                                                                                                                                                                                                                                                                                                  |
|--------------------------|------------------------------------------------------------------------------------------------------------------------------------------------------------------------------------------------------------------------------------------------------------------------------------------------------------------------------------------------------------------------------------------------------------------------------------------------------------------|
| <SegmentTime>            | <p>Duration of the sweep in the segment. See <code>[SENSe&lt;Ch&gt;:]SEGMENT&lt;Seg&gt;:SWEep:TIME</code>. In the setting <code>[SENSe&lt;Ch&gt;:]SEGMENT&lt;Seg&gt;:INSert:SElect DWELL</code>, this parameter is replaced by <code>&lt;MeasDelay&gt;</code>.</p> <p>Range: Depending on other channel settings. AUTO activates automatic sweep time setting in the segment, which is equivalent to the minimum sweep time possible.</p> <p>Default unit: s</p> |
| <MeasDelay>              | <p>Delay for each partial measurement in the segment. See <code>[SENSe&lt;Ch&gt;:]SEGMENT&lt;Seg&gt;:SWEep:DWELL</code>. In the setting <code>[SENSe&lt;Ch&gt;:]SEGMENT&lt;Seg&gt;:INSert:SElect SWTime</code>, this parameter is replaced by <code>&lt;SegmentTime&gt;</code>.</p>                                                                                                                                                                              |
| <Unused>                 | <p>Ignored parameter (for compatibility with R&amp;S ZVR analyzers). Should be set to the default value 0.</p>                                                                                                                                                                                                                                                                                                                                                   |
| <MeasBandwidth>          | <p>IF bandwidth in the segment. See <code>[SENSe&lt;Ch&gt;:]SEGMENT&lt;Seg&gt;:BWIDth[:RESolution]</code>.</p> <p>Default unit: Hz</p>                                                                                                                                                                                                                                                                                                                           |
| <LO>                     | <p>POSitive   NEGative   AUTO</p> <p>Position of the local oscillator frequency LO relative to the RF frequency. In remote control this parameter must be set when a sweep segment is created.</p> <p>Must be set to AUTO.</p>                                                                                                                                                                                                                                   |
| <Selectivity>            | <p>NORMal</p> <p>Selectivity of the IF filter; must be set to NORMal.</p>                                                                                                                                                                                                                                                                                                                                                                                        |
| <Mode>                   | <p>AUTO</p> <p>Ignored.</p>                                                                                                                                                                                                                                                                                                                                                                                                                                      |
| <FreqSweepMode>          | <p>STEPped</p> <p>Frequency sweep mode; must be set to STEPped.</p>                                                                                                                                                                                                                                                                                                                                                                                              |
| <b>Example:</b>          | <pre>SEGM:INS 1MHZ, 1.5MHZ, 111, -21DBM, 0.5S, 0, 10KHZ</pre> <p>Create a sweep segment with a sweep range between 1.0 MHz and 1.5 MHz.</p> <pre>SEGM2:ADD</pre> <p>Create a second sweep segment. The frequency range of the second segment will be between 1.5 MHz and the maximum frequency of the analyzer.</p>                                                                                                                                              |
| <b>Manual operation:</b> | See <a href="#">"Add / Insert / Delete / Delete All"</a> on page 362                                                                                                                                                                                                                                                                                                                                                                                             |

**[SENSe<Ch>:]SEGMENT<Seg>:INSert:SElect <TimeRef>**

Defines whether the sweep time of a new segment, i.e. numeric parameter no. 5 of the command `[SENSe<Ch>:]SEGMENT<Seg>:INSert`, is entered as a segment sweep time ("Segment Time") or as a measurement delay ("Meas Delay").

**Suffix:**

<Ch> Channel number  
<Seg> Sweep segment number

**Parameters:**

<TimeRef> SWTime | DWELL  
SWTime - use segment sweep time.  
DWELL - use measurement delay.  
\*RST: SWTime

**Example:**

```
SEGM1:INS:SEL DWELL
Select the meas. delay to determine the sweep time in a new
sweep segment no. 1.
SEGM1:INS 1MHZ, 1.5MHZ, 111, -21DBM, 0.01S, 0,
10KHZ
Create a sweep segment with a sweep range between 1.0 MHz
and 1.5 MHz and a meas. delay of 10 ms.
SEGM1:SWE:TIME?
Query the sweep time in the new segment.
```

**Manual operation:** See ["Optional Columns"](#) on page 364

**[SENSe<Ch>:]SEGMENT<Seg>:POWER[:LEVel] <IntSourcePow>**

Defines the power of the internal signal source in sweep segment no. <Seg>. At the same time, the command activates separate power control in all sweep segments (`[SENSe<Ch>:]SEGMENT<Seg>:POWER[:LEVel]:CONTrol`).

**Suffix:**

<Ch> Channel number  
<Seg> Sweep segment number

**Parameters:**

<IntSourcePow> Internal source power  
Range: -300 dBm to +200 dBm. The usable power range is frequency-dependent; refer to the data sheet.  
\*RST: -10 dBm  
Default unit: dBm

**Example:**

```
SEGM:ADD
Create a new sweep segment no. 1 in channel no. 1 using
default settings and thus -10 dBm internal source power.
SEGM:POW -20
Decrease the power to -20 dBm.
```

**Manual operation:** See ["Optional Columns"](#) on page 364

**[SENSe<Ch>:]SEGMENT<Seg>:POWER[:LEVEL]:CONTROL <Boolean>**

Selects common or independent internal source "Power" settings for the sweep segments.

**Suffix:**

<Ch> Channel number

<Seg> Sweep segment number. This suffix is ignored; the setting controls the whole segmented sweep.

**Parameters:**

<Boolean> ON – use independent power settings, to be defined via `[SENSe<Ch>:]SEGMENT<Seg>:POWER[:LEVEL]`.  
 OFF – reset the power in all sweep segments to the power for unsegmented sweeps, defined via `SOURCE<Ch>:POWER<PhyPt>[:LEVEL] [:IMMEDIATE] [:AMPLITUDE]`. ON will not restore the previous values.  
 The parameter is automatically switched to ON when a segment power is entered using `[SENSe<Ch>:]SEGMENT<Seg>:POWER[:LEVEL]`.

\*RST: OFF

**Example:**

```
SEGM:ADD
Create a new sweep segment no. 1 in channel no. 1 using
default settings and thus -10 dBm internal source power.
SEGM:POW -20
Decrease the power to -20 dBm.
SEGM:POW:CONT OFF
Couple the powers in all segments and reset the power in segment no. 1 to the initial value.
```

**Manual operation:** See "Optional Columns" on page 364

**[SENSe<Ch>:]SEGMENT<Seg>:SWEep:DWELI <MeasDelay>**

Defines the delay time for each partial measurement in sweep segment no. <Seg> ("Meas. Delay"). If coupling of the segments is switched on (`[SENSe<Ch>:]SEGMENT<Seg>:SWEep:DWELI:CONTROL ON`), the delay is valid for all sweep segments in the current channel.

**Suffix:**

<Ch> Channel number

<Seg> Sweep segment number

**Parameters:**

<MeasDelay> Measurement delay before each partial measurement. Changing the delay leaves the number of points unchanged but has an impact on the duration of the sweep (`[SENSe<Ch>: ] SEGMENT<Seg>: SWEep: TIME`).

Range: 0 s to 2500 s  
 \*RST: 0 s  
 Default unit: s

**Example:**

```
SEGM:ADD
Create a new sweep segment no. 1 in channel no. 1 using
default settings.
SEGM:SWE:DWEL 1 MS
Set the meas. delay in segment no. 1 to 1 ms.
SEGM:DEF? Response:
300000,8000000000,51,-300,0.056559,0,10000,POS,
NORM
Query the channel parameters for sweep segment 1. The
response value for the segment sweep time (olive) implicitly con-
tains the defined meas. delay.
```

**Manual operation:** See "[Optional Columns](#)" on page 364

---

`[SENSe<Ch>: ] SEGMENT<Seg>: SWEep: DWEL: CONTROL <Boolean>`

Selects common or independent "Meas. Delay" settings for the sweep segments.

**Suffix:**

<Ch> Channel number.

<Seg> Sweep segment number. This suffix is ignored; the command controls the whole segmented sweep.

**Parameters:**

<Boolean> ON – use independent delay settings, to be defined via `[SENSe<Ch>: ] SEGMENT<Seg>: SWEep: DWEL1`.  
 OFF – reset the delay in all sweep segments to the delay for unsegmented sweeps, defined via `[SENSe<Ch>: ] SWEep: DWEL1`.

The parameter is automatically switched to ON when a meas. delay time is entered using `[SENSe<Ch>: ] SEGMENT<Seg>: SWEep: DWEL1`.

\*RST: OFF

**Example:**            `SEGM:ADD`  
 Create a new sweep segment no. 1 in channel no. 1 using default settings and thus 0 s meas. delay.  
`SEGM:SWE:DWELL 0.1`  
 Increase the meas. delay to 0.1 s.  
`SEGM:SWE:DWELL:CONT OFF`  
 Couple the meas. delay in all segments and reset the delay in segment no. 1 to the initial value of 0 s.

**Manual operation:** See "[Optional Columns](#)" on page 364

### **[SENSe<Ch>:]SEGMENT<Seg>:SWEep:POINTs <SegPoint>**

Defines the total number of measurement points in sweep segment no. <Seg>.

**Suffix:**

<Ch>                    Channel number  
 <Seg>                   Sweep segment number

**Parameters:**

<SegPoint>            Number of points in the segment  
 Range:                1 to 100001. 1 is allowed if start and stop frequencies are equal.  
 \*RST:                 51

**Example:**            `SEGM:ADD`  
 Create a new sweep segment no. 1 in channel no. 1 using default settings.  
`SEGM:SWE:POIN 401`  
 Increase the number of points to 401.

**Manual operation:** See "[Table Columns](#)" on page 361

### **[SENSe<Ch>:]SEGMENT<Seg>:SWEep:TIME <SegSweepTime>**

Sets the duration of the sweep in sweep segment no. <Seg> ("Segment Time"). At the same time, the command activates separate sweep time setting in all sweep segments (`[SENSe<Ch>:]SEGMENT<Seg>:SWEep:TIME:CONTROL ON`).

**Suffix:**

<Ch>                    Channel number  
 <Seg>                   Sweep segment number



**Parameters:**

&lt;SegSweepTime&gt;

Segment time. The minimum segment time depends on the other channel settings, in particular on the number of points (`[SENSe<Ch>:]SEGMENT<Seg>:SWEep:POINTs`), the IF bandwidth (`[SENSe<Ch>:]SEGMENT<Seg>:BWIDth[:RESolution]`) and the delay for each partial measurement (`[SENSe<Ch>:]SEGMENT<Seg>:SWEep:DWELL`). The maximum is 1000 s. Changing the duration leaves the number of points unchanged but directly affects the delay.

Range: Minimum value to 1000 s

\*RST: Minimum value, depending on the channel settings. This default value corresponds to automatic sweep time setting in manual control.

Default unit: s

**Example:**

```
SEGM:ADD
```

Create a new sweep segment no. 1 in channel no. 1.

```
SEGM:SWE:TIME 0.1
```

Increase the segment sweep time to 0.1 s.

```
SEGM:SWE:TIME:SUM?
```

Query the total duration of the segmented sweep. The response is 0.1, because there is only one sweep segment.

**Manual operation:** See "[Optional Columns](#)" on page 364

**[SENSe<Ch>:]SEGMENT<Seg>:SWEep:TIME:CONTROL** <Boolean>

Selects common or independent "Segment Sweep Time" settings for the sweep segments.

**Suffix:**

&lt;Ch&gt;

Channel number

&lt;Seg&gt;

Sweep segment number. This suffix is ignored; the command controls the whole segmented sweep.

**Parameters:**

&lt;Boolean&gt;

ON – use independent segment sweep time settings, to be defined via `[SENSe<Ch>:]SEGMENT<Seg>:SWEep:TIME`.

OFF – reset the segment sweep time in all sweep segments to the segment sweep time for unsegmented sweeps, defined via `[SENSe<Ch>:]SWEep:TIME`. ON will not restore the previous values.

The parameter is automatically switched to ON when a segment sweep time is entered using `[SENSe<Ch>:]SEGMENT<Seg>:SWEep:TIME` or if the channel settings in a sweep segment require a sweep time larger than the unsegmented sweep time.

\*RST: OFF

**Example:**                   SEGM:ADD  
 Create a new sweep segment no. 1 in channel no. 1.  
 SEGM:SWE:TIME 0.1  
 Increase the segment sweep time to 0.1 s.  
 SEGM:SWE:TIME:CONT OFF  
 Couple the sweep times in all segments and reset the sweep  
 time in segment no. 1 to the initial value.

**Manual operation:**   See "Optional Columns" on page 364

---

#### [SENSe<Ch>:]SEGMENT<Seg>:SWEep:TIME:SUM?

Returns the total duration of the segmented sweep, calculated as the sum of the sweep times of the individual segments ([SENSe<Ch>:]SEGMENT<Seg>:SWEep:TIME).

**Suffix:**

<Ch>                   Channel number.

<Seg>                   Sweep segment number. This suffix is ignored; the command returns the sum of all segments.

**Example:**                   See [SENSe<Ch>:]SEGMENT<Seg>:SWEep:TIME

**Usage:**                   Query only

**Manual operation:**   See "Optional Columns" on page 364

#### 8.3.14.16 [SENSe:]SWEep...

The [SENSe:]SWEep... commands provide general settings to control the sweep. Most of the settings have an impact on the sweep time.

|                                      |     |
|--------------------------------------|-----|
| [SENSe:]SWEep:COUNT:ALL.....         | 982 |
| [SENSe<Ch>:]SWEep:COUNT.....         | 983 |
| [SENSe<Ch>:]SWEep:DETECTOR:TIME..... | 983 |
| [SENSe<Ch>:]SWEep:DWELL.....         | 984 |
| [SENSe<Ch>:]SWEep:DWELL:IPOINT.....  | 984 |
| [SENSe<Ch>:]SWEep:POINTS.....        | 985 |
| [SENSe<Ch>:]SWEep:STEP.....          | 985 |
| [SENSe<Ch>:]SWEep:TIME.....          | 986 |
| [SENSe<Ch>:]SWEep:TIME:AUTO.....     | 987 |
| [SENSe<Ch>:]SWEep:TYPE.....          | 988 |
| [SENSe<Chn>:]SWEep:SRCPort.....      | 989 |

---

#### [SENSe:]SWEep:COUNT:ALL <Sweep>

Defines the number of sweeps to be measured in single sweep mode (INITiate<Ch>:CONTinuous OFF). The setting is applied to all channels. Use [SENSe<Ch>:]SWEep:COUNT to define the sweep count for a single channel.

**Setting parameters:**

<Sweep>            Number of consecutive sweeps to be measured.  
 Range:            1 to 100000  
 \*RST:            1

**Example:**            See [Chapter 9.2.4, "Data Handling"](#), on page 1131.

**Usage:**                Setting only

**Manual operation:**    See "[Sweeps](#)" on page 371

**[SENSe<Ch>:]SWEep:COUNT <Sweep>**

Defines the channel-specific number of sweeps to be measured and buffered in single sweep mode ([INITiate<Ch>:CONTinuous OFF](#)). Use [\[SENSe:\]SWEep:COUNT:ALL](#) to define the sweep count for all channels.

**Suffix:**

<Ch>                    Channel number

**Parameters:**

<Sweep>                Number of consecutive sweeps to be measured and buffered.  
 Range:            1 to 100000  
 \*RST:            1

**Example:**            See [CALCulate<Chn>:DATA:NSWep:FIRSt?](#)

**Manual operation:**    See "[Sweeps](#)" on page 371

**[SENSe<Ch>:]SWEep:DETEctor:TIME <DetectorTime>**

Defines the observation time per sweep point if a detector other than the "Normal" (SAMPLE) detector is used. The detector is selected together with the measured quantity ([CALCulate<Ch>:PARAmeter:MEASure](#) or [CALCulate<Ch>:PARAmeter:SDEFine](#)).

**Suffix:**

<Ch>                    Channel number

**Parameters:**

<DetectorTime>        Detector time  
 Range:            0 s to 3456000 s  
 \*RST:            0.01 s  
 Default unit: s

**Example:**            \*RST; :CALC:PAR:MEAS 'TRC1', 'a1D1AVG'  
 Select the wave quantity a<sub>1</sub> for the default trace and activate the AVG detector.  
 SWE:DET:TIME 1  
 Specify an observation time of 1 s at each sweep point.

**Manual operation:**    See "[Detector](#)" on page 234

**[SENSe<Ch>:]SWEep:DWELI <MeasDelay>**

Defines the "Meas. Delay" before each partial measurement or the first partial measurement (see [SENSe<Ch>:]SWEep:DWELI:IPOint). Setting a delay disables the automatic calculation of the (minimum) sweep time (see [SENSe<Ch>:]SWEep:TIME:AUTO).

**Suffix:**

<Ch> Channel number

**Parameters:**

<MeasDelay> Measurement delay before each partial measurement. Changing the delay leaves the number of points unchanged but has an impact on the duration of the sweep ([SENSe<Ch>:]SWEep:TIME).

Range: 0 s to 13680 s

\*RST: 0 s

Default unit: s

**Example:**

\*RST

Reset the instrument, activating a frequency sweep with the S-parameter  $S_{21}$  as a measurement result for channel and trace no. 1.

SWEep:TIME?

Query total sweep time.

SWEep:DWEL 1

SWEep:DWEL:IPOint ALL

Set a delay of 1 s for each partial measurement.

SWE:TIME?

Query total sweep time. The time is extended by the delay times the total number of sweep points (one partial measurement per sweep point required).

**Manual operation:** See "Meas Delay" on page 354

**[SENSe<Ch>:]SWEep:DWELI:IPOint <InsertionPoints>**

Defines whether the measurement delay (previously defined via [SENSe<Ch>:]SWEep:DWELI) is inserted before all partial measurements or before the first partial measurement only.

**Suffix:**

<Ch> Channel number

**Parameters:**

<InsertionPoints> ALL | FIRSt

Insertion before all or before the first partial measurement

\*RST: ALL

**Example:**

See [SENSe<Ch>:]SWEep:DWELI

**Manual operation:** See ["All Partial Meas'ments / First Partial Meas'ment"](#) on page 354

---

**[SENSe<Ch>:]SWEep:POINts <SweepPoint>**

Defines the total number of measurement points per sweep ("Number of Points").

Values between 1 and 5,001 can be set.

**Suffix:**

<Ch> Channel number 1

**Parameters:**

<SweepPoint> Number of points per sweep

Range: see above

\*RST: 201

**Example:**

\*RST

Reset the instrument, activating a frequency sweep with 201 sweep points.

SWE:TIME?

Query total sweep time.

SWE:POIN 2010

Multiply the (default) number of points by 10.

SWE:TIME?

Query total sweep time again. The analyzer estimates a sweep time that is also multiplied by 10.

**Manual operation:** See ["Number of Points"](#) on page 346

---

**[SENSe<Ch>:]SWEep:STEP <StepSize>**

Sets the distance between two consecutive sweep points in a (non-segmented) linear frequency sweep.

**Suffix:**

<Ch> Channel number

**Parameters:**

&lt;StepSize&gt;

Frequency step size.

The step size is equal to the current sweep span divided by the number of sweep points minus one (see [\[SENSe<Ch>:\]FREQuency:SPAN?](#) and [\[SENSe<Ch>:\]SWEep:POINts?](#), respectively). See also the description of manual control and the program example below.

Range: Depends on the current sweep span and the maximum number of sweep points: "Span Frequency" / (max. "Number of Points" – 1) ≤ "Freq Step Size" ≤ "Span Frequency"

\*RST: Depends on the analyzer model. The default step size is equal to the default sweep span of the analyzer divided by the default number of sweep points minus one.

Default unit: Hz

**Example:**

```
*RST; :SWE:STEP?
```

Query the default step size. Currently for all analyzers the default sweep span is the full frequency range and the default number of points is 201. Hence the response is (max. frequency - min. frequency) / 200.

```
SWE:STEP UP
```

Increase the step size.

```
FREQ:STOP?; :SWE:POIN?
```

Query the stop frequency of the sweep and the number of points. Increasing the step size has changed both values.

**Manual operation:** See "[Freq Step Size](#)" on page 353

**[SENSe<Ch>:]SWEep:TIME <SweepDuration>**

Sets the duration of the sweep ("Sweep Time"). Setting a sweep time disables the automatic calculation of the (minimum) sweep time; see [\[SENSe<Ch>:\]SWEep:TIME:AUTO](#).

**Note:** The sweep time is ignored for the sweep types "Time" and "CW Mode" ([\[SENSe<Ch>:\]SWEep:TYPE](#)).

**Suffix:**

&lt;Ch&gt;

Channel number

**Parameters:**

<SweepDuration> Sweep time. The minimum possible sweep time depends on the other channel settings, in particular on the number of points (`[SENSe<Ch>:]SWEep:POINts`), the IF bandwidth (`[SENSe<Ch>:]BWIDth[:RESolution]`) and the measurement delay for each partial measurement (`[SENSe<Ch>:]SWEep:DWELl`). Changing the duration leaves the number of points unchanged but directly affects the delay.

Range: Between minimum sweep time (for current channel settings) and 100000 s

\*RST: Minimum sweep time (for \*RST channel settings)

Default unit: s

**Example:**

```
SWE:TIME 1
Set a total sweep time of 1 s.
SWE:DWEL?
Query the delay for each partial measurement.
SWE:TIME 2
Increase the total sweep time to 2 s.
SWE:DWEL?
Query the meas. delay for each partial measurement again. The
delay is increased by 1 s divided by the total number of partial
measurements per sweep.
```

**Manual operation:** See "[Sweep Time / Auto](#)" on page 354

**[SENSe<Ch>:]SWEep:TIME:AUTO <Boolean>**

When enabled, the (minimum) sweep time is calculated internally using the other channel settings and zero delay (`[SENSe<Ch>:]SWEep:DWELl`).

**Note:** The automatically calculated sweep duration is ignored for the sweep types "Time" and "CW Mode" (`[SENSe<Ch>:]SWEep:TYPE`).

**Suffix:**

<Ch> Channel number

**Parameters:**

<Boolean> ON | OFF - turn the automatic calculation of the sweep time on or off.  
 OFF is also set if the sweep duration or delay is set explicitly using `[SENSe<Ch>:]SWEep:TIME` or `[SENSe<Ch>:]SWEep:DWELl`.

\*RST: ON

**Example:**

```
SWE:TIME 1
Set a total sweep time of 1 s.
SWE:TIME:AUTO?
A query returns the value 1.
```

**Manual operation:** See "[Sweep Time / Auto](#)" on page 354

**[SENSe<Ch>:]SWEep:TYPE <Format>**

Selects the sweep type, i.e. the sweep variable (frequency/power/time) and the position of the sweep points across the sweep range.

**Suffix:**

<Ch> Channel number.

**Parameters:**

<Format> LINear | LOGarithmic | POWer | CW | POINT | SEGMENT

**LINear**

Linear frequency sweep at constant source power

(`SOURce<Ch>:POWer<PhyPt>[:LEVel] [:IMMediate] [:AMPLitude]`). The stimulus frequency (`[SENSe<Ch>:]FREQuency:...`) is swept in equidistant steps over the frequency range. In a Cartesian diagram, the x-axis is a linear frequency axis.

**LOGarithmic**

Logarithmic frequency sweep. The frequency is swept in equidistant steps on a logarithmic scale. In a Cartesian diagram, the x-axis is a logarithmic frequency axis.

**POWer**

Power sweep. The measurement is performed at constant frequency (`SOURce<Ch>:FREQuency<PhyPt>:FIXed`) but with variable generator power that is swept in linear, equidistant steps over a continuous range

(`SOURce<Ch>:POWer<PhyPt>:START, SOURce<Ch>:POWer<PhyPt>:STOP`). In a Cartesian diagram, the x-axis is a dB-linear power axis.

**CW**

Time sweep. The measurement is performed at constant frequency (`SOURce<Ch>:FREQuency<PhyPt>:FIXed`) and source power (`SOURce<Ch>:POWer<PhyPt>[:LEVel] [:IMMediate] [:AMPLitude]`) and repeated over a specified period of time at constant time intervals.

**POINT**

CW mode sweep, time sweep triggered according to the current trigger settings.

SEGMENT - segmented frequency sweep. The sweep range is composed of several continuous frequency ranges or single frequency points defined by means of the commands in the `[SENSe<Ch>:]SEGMENT<Seg>... subsystem`.

\*RST: LINear

**Example:**

\*RST

Reset the analyzer, activating a linear frequency sweep.

SWE:TYPE LOG

Change to a logarithmic frequency sweep, resetting the stimulus values of the sweep points.



**Manual operation:** See "Lin Freq" on page 355

---

### [SENSe<Chn>:]SWEep:SRCPort <Port>

Sets/gets the source port for the stimulus signal. The setting acts on the active trace. The effect of the drive port selection depends on the measurement parameter associated to the active trace:

- If an S-parameter  $S_{<out><in>}$  is measured, the second port number index <in> (input port of the DUT = drive port of the analyzer) is set equal to the selected drive port: Drive port selection affects the measured quantity.
- If a wave quantity or a ratio is measured, the drive port is independent of the measured quantity:

**Suffix:**

<Chn> Channel number used to identify the active trace

**Parameters:**

<Port> Logical port number  
\*RST: 1

**Example:**

```
CALC4:PAR:SDEF "Ch4Tr1", "A1"
```

Create channel 4 and a trace named "Ch4Tr1" to measure the wave quantity  $a_1$ . The trace automatically becomes the active trace.

```
SENS4:SWE:SRCP 2
```

Select drive port 2 for the active trace.

```
CALC4:PAR:MEAS? "Ch4Tr1"
```

Query the measurement result for "Ch4Tr1". The response is 'A1D2SAM'.

## 8.3.15 SOURce Commands

The `SOURce...` commands affect the source settings of the R&S ZND.

### 8.3.15.1 SOURce:FREQuency...

The `SOURce:FREQuency...` commands configure the sources for frequency conversion measurements and control the frequency and power of the internal signal source.

|                                                                  |     |
|------------------------------------------------------------------|-----|
| <code>SOURce&lt;Ch&gt;:FREQuency&lt;PhyPt&gt;[:CW]</code> .....  | 989 |
| <code>SOURce&lt;Ch&gt;:FREQuency&lt;PhyPt&gt;:FIXed</code> ..... | 989 |

---

**SOURce<Ch>:FREQuency<PhyPt>[:CW]** <FixedFreq>

**SOURce<Ch>:FREQuency<PhyPt>:FIXed** <FixedFreq>

Defines the fixed (Continuous Wave, CW) frequency for all sweep types operating at fixed frequency ("Power", "Time", "CW Mode"). The two command forms

`SOURce<Ch>:FREQuency<PhyPt>:CW` and

`SOURce<Ch>:FREQuency<PhyPt>:FIXed` are equivalent.

The frequency range is listed in [Table 8-15](#).

**Note:** `SOURce<Ch>:FREQuency<PhyPt>[:CW] | :FIXed` is equivalent to `[SENSE<Ch>:]FREQuency[:CW] | :FIXed`. Source and receiver frequency are always equal; the four commands overwrite each other.

**Suffix:**

|         |                                                                                                                                            |
|---------|--------------------------------------------------------------------------------------------------------------------------------------------|
| <Ch>    | Channel number                                                                                                                             |
| <PhyPt> | Test port number of the analyzer. This suffix is ignored because the selected frequency applies to all source ports in the active channel. |

**Parameters:**

|             |                                                                           |
|-------------|---------------------------------------------------------------------------|
| <FixedFreq> | Fixed stimulus and analyzer frequency.<br>*RST: 1 GHz<br>Default unit: Hz |
|-------------|---------------------------------------------------------------------------|

**Example:**

```
FUNC "XTIME:POW:A1"
```

Activate a time sweep and select the wave quantity  $a_1$  as measured parameter for channel and trace no. 1.

```
FREQ:CW 100MHz
```

Set the CW frequency to 100 MHz.

**Manual operation:** See "[CW Frequency](#)" on page 346

### 8.3.15.2 SOURce:LPORt...

The `SOURce:LPORt...` commands define the logical port configuration (balanced ports, renumbered single-ended ports).

|                                                              |     |
|--------------------------------------------------------------|-----|
| <code>SOURce&lt;Ch&gt;:LPORt&lt;LogPt&gt;</code> .....       | 990 |
| <code>SOURce&lt;Ch&gt;:LPORt&lt;LogPt&gt;:CLEar</code> ..... | 991 |

---

**SOURce<Ch>:LPORt<LogPt> <PhysicalPort>[, <PhysicalPort>]**

Assigns the logical port number <LogPt> either to the single-ended physical port <PhysicalPort1> or to a pair of physical ports <PhysicalPort1>,<PhysicalPort2>, at the same time defining them as balanced port.

**Important:**

- All required logical ports (balanced and single ended) must be created explicitly.
- A balanced port configuration generally introduces a new set of mixed mode measured quantities. Therefore the traces must be redefined when a balanced port is created. To avoid any inconsistencies the analyzer deletes all traces when `SOURce<Ch>:LPORt<LogPt>` is used.
- It is essential to complete the logical port assignment before defining other port properties such as common or differential mode impedances: whenever a logical port is created using `SOURce<Ch>:LPORt<LogPt>`, the parameters of all existing logical ports are reset.
- For a unidirectional R&S ZND (see [Chapter 5.1.4.3, "R&S ZND: Unidirectional vs. Bidirectional Operation"](#), on page 75) balanced ports are not available.

|                          |                                                                                                                                                                                                                                                        |
|--------------------------|--------------------------------------------------------------------------------------------------------------------------------------------------------------------------------------------------------------------------------------------------------|
| <b>Suffix:</b>           |                                                                                                                                                                                                                                                        |
| <Ch>                     | Channel number.                                                                                                                                                                                                                                        |
| <LogPt>                  | Identifying number of the newly created balanced or single-ended logical port.<br>Must be between 1 and the number of physical ports (see <a href="#">INSTrument:TPORt:COUNT?</a> ). If unspecified the numeric suffix is set to 1.                    |
| <b>Parameters:</b>       |                                                                                                                                                                                                                                                        |
| <PhysicalPort>           | Number of first/only physical port<br>Range: 1 to number of physical ports                                                                                                                                                                             |
| <PhysicalPort>           | Number of second physical port (optional), forming a balanced port with the first physical port.<br>The port numbers must be different. Moreover, a physical port cannot be assigned to several logical ports.<br>Range: 1 to number of physical ports |
| <b>Example:</b>          | <pre>*RST; :SOUR:LPOR1 1,2</pre> <p>Combine the physical ports 1 and 2 to the logical port 1 (balanced)</p> <pre>SOUR:LPOR1?</pre> <p>Query the physical ports assigned to logical port no. 1. The response is 1, 2.</p>                               |
| <b>Manual operation:</b> | See <a href="#">"Select Predefined Port"</a> on page 227                                                                                                                                                                                               |

---

**SOURce<Ch>:LPORt<LogPt>:CLEar [<Scope>]**

Dissolves balanced port <LogPt> or all logical ports.

|                            |                                                                                                                                                                                                                                                                                                 |
|----------------------------|-------------------------------------------------------------------------------------------------------------------------------------------------------------------------------------------------------------------------------------------------------------------------------------------------|
| <b>Suffix:</b>             |                                                                                                                                                                                                                                                                                                 |
| <Ch>                       | Channel number                                                                                                                                                                                                                                                                                  |
| <LogPt>                    | Logical port number used to number balanced ports.<br>Range according to the current port configuration ( <a href="#">SOURce&lt;Ch&gt;:LPORt&lt;LogPt&gt;</a> ). If an undefined balanced port number is used, the analyzer generates an error message.<br>Exception: Parameter ALL, see below. |
| <b>Setting parameters:</b> |                                                                                                                                                                                                                                                                                                 |
| <Scope>                    | ALL<br>If ALL is specified, all logical ports are dissolved; the <log_port> suffix is ignored. If ALL is omitted, only the specified balanced port is dissolved.                                                                                                                                |
| <b>Example:</b>            | See <a href="#">SOURce&lt;Ch&gt;:LPORt&lt;LogPt&gt;</a>                                                                                                                                                                                                                                         |
| <b>Usage:</b>              | Setting only                                                                                                                                                                                                                                                                                    |
| <b>Manual operation:</b>   | See <a href="#">"Select Predefined Port"</a> on page 227                                                                                                                                                                                                                                        |

### 8.3.15.3 SOURce:GROup...

The `SOURce:GROup...` commands define the group of (un-)used logical ports.

|                                                             |     |
|-------------------------------------------------------------|-----|
| <code>SOURce&lt;Ch&gt;:GROup&lt;Grp&gt;</code> .....        | 992 |
| <code>SOURce&lt;Ch&gt;:GROup&lt;Grp&gt;:CLEar</code> .....  | 992 |
| <code>SOURce&lt;Ch&gt;:GROup&lt;Grp&gt;:PORTs</code> .....  | 993 |
| <code>SOURce&lt;Ch&gt;:GROup&lt;Grp&gt;:PPORts</code> ..... | 993 |

---

#### `SOURce<Ch>:GROup<Grp> <arg0>, <arg1>`

In "set direction" this command defines the set of active logical ports (the "master group") as the continuous range from `<log_port1>` to `<log_port2>`, i.e. logical ports outside this range are disabled.

In "get direction" it returns the minimum and maximum enabled logical port.

See `SOURce<Ch>:LPORt<LogPt>` on how to define logical ports.

#### Suffix:

|                          |                                            |
|--------------------------|--------------------------------------------|
| <code>&lt;Ch&gt;</code>  | Channel number.                            |
| <code>&lt;Grp&gt;</code> | Port group number, must be 1 (or omitted). |

#### Parameters:

|                           |                                                                                                          |
|---------------------------|----------------------------------------------------------------------------------------------------------|
| <code>&lt;arg0&gt;</code> |                                                                                                          |
| <code>&lt;arg1&gt;</code> | First and last logical port number in the port group. Must be omitted if the command is used as a query. |

**Example:** See `SOURce<Ch>:LPORt<LogPt>` on page 990

---

#### `SOURce<Ch>:GROup<Grp>:CLEar [<arg0>]`

Dissolves the "master port group", i.e. reenables all logical ports.

#### Suffix:

|                          |                                                                                             |
|--------------------------|---------------------------------------------------------------------------------------------|
| <code>&lt;Ch&gt;</code>  | Channel number.                                                                             |
| <code>&lt;Grp&gt;</code> | Port group number.<br>This suffix is ignored: only <code>&lt;Grp&gt;=1</code> is supported. |

#### Setting parameters:

|                           |                                                                                                                                                                                                                                                                                                                                                                                                                                                        |
|---------------------------|--------------------------------------------------------------------------------------------------------------------------------------------------------------------------------------------------------------------------------------------------------------------------------------------------------------------------------------------------------------------------------------------------------------------------------------------------------|
| <code>&lt;arg0&gt;</code> | ALL<br>If ALL is specified, all port groups are dissolved and a default port group 1, consisting of all available ports, is restored; the <code>&lt;Grp&gt;</code> suffix is ignored.<br>If ALL is omitted, only the specified port group is dissolved, except the deleted port group was the only one, in which case again default port group 1 is restored. In case an undefined port group number is used, the analyzer generates an error message. |
|---------------------------|--------------------------------------------------------------------------------------------------------------------------------------------------------------------------------------------------------------------------------------------------------------------------------------------------------------------------------------------------------------------------------------------------------------------------------------------------------|

**Example:** See `SOURce<Ch>:LPORt<LogPt>` on page 990

**Usage:** Setting only

---

**SOURce<Ch>:GROup<Grp>:PORTs** <arg0>[, <arg1>]...

Defines the set of active logical ports (the "master group") as an arbitrary selection of logical ports. The ports do not have to be numbered consecutively (as for port groups defined via [SOURce<Ch>:GROup<Grp>](#)).

See [SOURce<Ch>:LPORt<LogPt>](#) on how to define logical ports.

**Suffix:**

<Ch> Channel number.

<Grp> Port group number, must be 1 (or omitted).

**Parameters:**

<arg0>

<arg1> Logical port numbers. Must be omitted if the command is used as a query.

---

**SOURce<Ch>:GROup<Grp>:PPORts** <pport1>,<pport2>...

Defines/queries port groups.

In "set direction" this command creates port group <Grp> from physical VNA ports <pport1>, <pport2>, ... In "get direction" it returns the physical VNA ports making up group <Grp>.

**Note**

- Port groups must be created in ascending order, i.e. first create port group 1, then port group 2 etc.
- By default there is a single port group, which contains all physical VNA ports ("default port group").
- Redefinition of an existing port group is not allowed (exception: "default port group"). Use [SOURce<Ch>:GROup<Grp>:CLEar](#) to dissolve existing port groups first.
- It is not allowed to assign the same physical VNA port to multiple port groups.
- When a port group is created, the number of ports of the corresponding DUT is set to the port group size and "aligned" port connections are established.

**Suffix:**

<Ch> Channel number

<Grp> Port group number

**Parameters:**

<pport1>,<pport2>... Physical VNA port numbers

### 8.3.15.4 SOURce:POWer...

The `SOURce:POWer...` commands define the power of the signal sources and control a scalar source power calibration.



#### Port-specific and general settings

The `SOURce:POWer...` subsystem comprises port-specific and general settings. Port-specific settings are valid for the port specified by the numeric suffix `<PhyPt>` (`...:POWer<PhyPt>:...`). General settings are valid for all test ports of the analyzer; the port suffix is ignored. Refer to the description of the individual commands for more information.

#### SOURce:POWer:CORRection...

The `SOURce:POWer:CORRection...` commands control a scalar source power calibration.

|                                                                                                             |      |
|-------------------------------------------------------------------------------------------------------------|------|
| <code>SOURce:POWer:CORRection:PMETer:ID</code> .....                                                        | 994  |
| <code>SOURce&lt;Ch&gt;:POWer:CORRection:DATA</code> .....                                                   | 995  |
| <code>SOURce&lt;Ch&gt;:POWer:CORRection:DATA:PARAmeter&lt;Wv&gt;?</code> .....                              | 996  |
| <code>SOURce&lt;Ch&gt;:POWer&lt;PhyPt&gt;:CORRection[:ACQuire]</code> .....                                 | 997  |
| <code>SOURce&lt;Ch&gt;:POWer&lt;PhyPt&gt;:CORRection[:ACQuire]:VERification:RESult?</code> .....            | 998  |
| <code>SOURce&lt;Ch&gt;:POWer&lt;PhyPt&gt;:CORRection:COLLect:AVERAge[:COUNT]</code> .....                   | 999  |
| <code>SOURce&lt;Ch&gt;:POWer&lt;PhyPt&gt;:CORRection:COLLect:AVERAge:NTOLerance</code> .....                | 999  |
| <code>SOURce&lt;Ch&gt;:POWer&lt;PhyPt&gt;:CORRection:COLLect:CFACtor</code> .....                           | 1000 |
| <code>SOURce&lt;Ch&gt;:POWer&lt;PhyPt&gt;:CORRection:COLLect:FLATness</code> .....                          | 1000 |
| <code>SOURce&lt;Ch&gt;:POWer&lt;PhyPt&gt;:CORRection:COLLect:METHod</code> .....                            | 1001 |
| <code>SOURce&lt;Ch&gt;:POWer&lt;PhyPt&gt;:CORRection:COLLect:RRECeiver</code> .....                         | 1002 |
| <code>SOURce:POWer:CORRection:COLLect:VNETworks</code> .....                                                | 1002 |
| <code>SOURce&lt;Ch&gt;:POWer&lt;PhyPt&gt;:CORRection:DATA:PARAmeter&lt;Wv&gt;:COUNT?</code> .....           | 1003 |
| <code>SOURce&lt;Ch&gt;:POWer&lt;PhyPt&gt;:CORRection:NREadings</code> .....                                 | 1003 |
| <code>SOURce&lt;Ch&gt;:POWer&lt;PhyPt&gt;:CORRection:OSources[:STATe]</code> .....                          | 1003 |
| <code>SOURce:POWer:CORRection:PPOWer</code> .....                                                           | 1004 |
| <code>SOURce&lt;Ch&gt;:POWer&lt;PhyPt&gt;:CORRection:PSElect</code> .....                                   | 1004 |
| <code>SOURce&lt;Ch&gt;:POWer&lt;PhyPt&gt;:CORRection:STATe</code> .....                                     | 1005 |
| <code>SOURce&lt;Ch&gt;:POWer&lt;PhyPt&gt;:CORRection:TCoefficient[:STATe]</code> .....                      | 1005 |
| <code>SOURce&lt;Ch&gt;:POWer&lt;PhyPt&gt;:CORRection:TCoefficient:CALibration</code> .....                  | 1005 |
| <code>SOURce&lt;Ch&gt;:POWer&lt;PhyPt&gt;:CORRection:TCoefficient:COUNT?</code> .....                       | 1007 |
| <code>SOURce&lt;Ch&gt;:POWer&lt;PhyPt&gt;:CORRection:TCoefficient:DEFine&lt;ListNo&gt;</code> .....         | 1007 |
| <code>SOURce&lt;Ch&gt;:POWer&lt;PhyPt&gt;:CORRection:TCoefficient:DELeTe&lt;ListNo&gt;:ALL</code> .....     | 1008 |
| <code>SOURce&lt;Ch&gt;:POWer&lt;PhyPt&gt;:CORRection:TCoefficient:DELeTe&lt;ListNo&gt;[:DUMMy]</code> ..... | 1008 |
| <code>SOURce&lt;Ch&gt;:POWer&lt;PhyPt&gt;:CORRection:TCoefficient:FEED</code> .....                         | 1008 |
| <code>SOURce&lt;Ch&gt;:POWer&lt;PhyPt&gt;:CORRection:TCoefficient:INSert&lt;ListNo&gt;</code> .....         | 1009 |

---

#### **SOURce:POWer:CORRection:PMETer:ID** <PowerMeter>

Selects an external power meter for the scalar source power calibration (flatness calibration).

**Note:** The command cannot be used unless a power meter is connected via GPIB bus, USB or LAN interface and configured in the "External Power Meters" dialog.

**Parameters:**

<PowerMeter>      Number of external power meter. The parameters UP, DOWN, MIN, MAX are not available for this command.

Range:            1 to number of configured external power meters

\*RST:            The power meter selection is not changed by a reset of the analyzer.

**Example:**            See `SOURce<Ch>:POWer<PhyPt>:CORRection:COLLect[:ACQuire]` on page 1107

**Manual operation:**    See "Power Meter" on page 416

**SOURce<Ch>:POWer:CORRection:DATA** <Source>, <CorrData>...

Reads or writes scalar source power correction data sets. A power correction data set contains n real values where:

- Each value corresponds to the ratio of the actual power at the reference plane (value provided by the used source) to the uncalibrated power in dB.
- The number n is equal to the number of sweep points.

Increasing (decreasing) the values in the correction data sets increases (decreases) the power at the reference plane. Writing correction data (the setting command) fails if the number of transferred values is not equal to the number of sweep points.

**Suffix:**

<Ch>                    Calibrated channel number

**Parameters:**

<Source>              Identifier for the source of the calibrated wave:  
'A<n>' or 'PORT<n>' denote correction data for the analyzer port no. <n>.

<CorrData>            Power correction values either in ASCII or block data format, depending on the current `FORMat[:DATA]` setting.  
All numbers are interpreted as dB-values.

**Example:**

\*RST; :SWE:POIN 10

Reset the instrument and reduce the number of sweep points to 10.

SOUR:POW:CORR:ACQ PORT,1

Perform a source power calibration using port 1 as a source port.

SOUR:POW:CORR:DATA? 'A1'

Query the correction values. The analyzer returns 10 comma-separated real numbers.

SOUR:POW:CORR:DATA 'A1', 1, 2, 3, 4, 5, -6, -7, -8, -9, -0

Replace the correction values by ten (new) numbers.

**Manual operation:**    See "Apply" on page 394

**SOURce<Ch>:POWER:CORRection:DATA:PARAmeter<Wv>?**

Gets settings of the available power calibrations.

**Suffix:**

|      |                                                                                                                                                                                                          |
|------|----------------------------------------------------------------------------------------------------------------------------------------------------------------------------------------------------------|
| <Ch> | Number of the calibrated channel.                                                                                                                                                                        |
| <Wv> | Number of the power calibration.<br>Use <a href="#">SOURce&lt;Ch&gt;:POWER&lt;PhyPt&gt;:CORRection:DATA:PARAmeter&lt;Wv&gt;:COUNT?</a> on page 1003 to query the number of available power calibrations. |

**Query parameters:**

|             |                                                                                                                                                                                                                                                   |
|-------------|---------------------------------------------------------------------------------------------------------------------------------------------------------------------------------------------------------------------------------------------------|
| SettingType | WAVE   START   STOP   POINTs   STYPE   ATTenuation   CPOWER   CFRequency   TSTamp   LTSTamp   FSMODE                                                                                                                                              |
|             | <b>WAVE</b><br>Calibrated port and calibration type (Gen=Source Power, Rec=Measurement Receiver)                                                                                                                                                  |
|             | <b>START</b><br>Start Frequency or Power<br>Stop Frequency or Power                                                                                                                                                                               |
|             | <b>POINTs</b><br>Nr. of sweep points                                                                                                                                                                                                              |
|             | <b>STYPE</b><br>Sweep type or grid (LIN, LOG, SEGM)                                                                                                                                                                                               |
|             | <b>ATTenuation</b><br>Source or receiver attenuation                                                                                                                                                                                              |
|             | <b>CPOWER</b><br>Cal Power for frequency sweeps                                                                                                                                                                                                   |
|             | <b>CFRequency</b><br>Cal Frequency for power sweeps                                                                                                                                                                                               |
|             | <b>TSTamp</b><br>Timestamp in UTC                                                                                                                                                                                                                 |
|             | <b>LTSTamp</b><br>Timestamp in local time                                                                                                                                                                                                         |
|             | <b>TVNA</b><br>For calibrations involving switch matrices, this indicates the test ports on the VNA itself. Returns a comma-separated list of port pairs <code>TestPort, VnaPort</code>                                                           |
|             | <b>MVNA</b><br>For calibrations involving switch matrices, this indicates the mapping between matrix ports and VNA ports for matrix <code>&lt;Index&gt;</code> . Returns a comma-separated list of port pairs <code>MatrixVnaPort, VnaPort</code> |



**MTEST**

For calibrations involving switch matrices, this indicates the mapping between matrix (physical) test ports and test ports for matrix <Index>. Returns a comma-separated list of port pairs  
 MatrixTestPort, TestPort

<Index> If one or more external switch matrices were used during calibration, this refers to the index of a particular switch matrix (see [SYSTem:COMMunicate:RDEvice:SMATrix<Matr>:DEFine](#) on page 1034)

**Usage:** Query only

**Manual operation:** See "[Port Overview](#)" on page 394

**SOURce<Ch>:POWER<PhyPt>:CORRection[:ACQuire] <SourceType>[, <SourcePort>[, <CalOnlyPortFreq>]]**

Selects the source for the source power calibration, starts and applies the source power calibration.

**Note:** The command cannot be used unless a power meter is connected via GPIB bus, USB or LAN interface and configured in the "External Power Meters" dialog.

**Suffix:**

<Ch> Calibrated channel number

<PhyPt> Calibrated port number. This suffix is ignored because the port number is specified in the parameter list.

**Setting parameters:**

<SourceType> PORT | A1 | A2 | A3 | A4

PORT – analyzer port is the source of the calibrated wave.

The port number is specified by means of the <SourcePort> parameter.

A1 | A2 | A3 | A4 – direct analyzer port selection. The parameters A1 and A2 are ZVR-compatible. No additional port number parameter needs to be specified.

<SourcePort> Analyzer port number, if PORT is the first parameter.

<CalOnlyPortFreq>

**Example:**

```
SOUR:POW:CORR:OSO:STAT OFF
```

To improve the accuracy, switch off all other sources during the calibration sweep.

```
SOUR:POW:CORR:NRE 2; COLL:AVER:NTOL 0.5
```

Increase the number of readings and reduce the power tolerance to improve the accuracy.

```
SOURce:POW:CORR:COLL:CFAC 0.9
```

Reduce the correction factor to 0.9.

```
SOURce:POW:CORR:PSElect PPOW; PPOWer -5
```

Define reference receiver cal power which is independent of the port power; set its value to -5 dBm.

```
SOUR:POW:CORR:ACQ PORT,1
```

Perform a source power calibration using port 1 as a source port.

```
SOUR:POW:CORR:STAT?
```

Check whether the calibration is applied (the response is 1).

**Usage:**

Setting only

**Manual operation:** See "[Port Overview](#)" on page 394

---

**SOURce<Ch>:POWER<PhyPt>:CORRection[:ACQuire]:VERification:RESult?**

Returns (and deletes) the result of the last verification sweep. The response contains three values:

- <Channel> – calibrated channel, e.g. Ch 1 for channel no. 1.
- <Boolean> – 1 for "calibration passed" (the maximumr offset is below the tolerance), 0 for "calibration failed".
- <MaxOffset> – maximum power offset between the measured power at the reference plane and the "Cal Power" during the verification sweep in dB.

If no verification sweep is available, or if the result has been queried already, the response is 0.

**Suffix:**

<Ch>

Calibrated channel number. This suffix is ignored; the result is based on the last verification sweep acquired.

<PhyPt>

Calibrated port number. This suffix is ignored; the result is based on the last verification sweep acquired.

**Example:** `*RST; :SOURce:POWer:CORRection:NREadings 2`  
`SOURce:POWer:CORRection:COLLect:AVERAge:`  
`NTOLerance 0.5`  
 Increase the number of readings and reduce the power tolerance to improve the accuracy.  
`SOURce:POWer:CORRection:ACQuire PORT,1`  
 Perform a source power calibration using port 1 as a source port.  
`SOURce:POWer:CORRection:ACQuire:VERification:RESult?`  
 Query the result of the verification sweep. Possible response:  
`Ch1 1,9.9E+002`

**Usage:** Query only

**Manual operation:** See "[Calibration Sweep Diagram](#)" on page 393

---

**SOURce<Ch>:POWer<PhyPt>:CORRection:COLLect:AVERAge[:COUNT]**  
 <NoReadings>

Sets a limit for the number of calibration sweeps in the source power calibration. The command is valid for all channels and ports.

Equivalent command: `SOURce<Ch>:POWer<PhyPt>:CORRection:NREadings`.

**Suffix:**

<Ch> Calibrated channel number. This parameter is ignored; the limit applies to all channels.

<PhyPt> Calibrated port number. This parameter is ignored; the limit applies to all sources.

**Parameters:**

<NoReadings> Number of readings  
 Range: 1 to 100  
 \*RST: 2

**Example:** See `SOURce<Ch>:POWer<PhyPt>:CORRection[:ACQuire]` (for equivalent command `SOURce<Ch>:POWer<PhyPt>:CORRection:NREadings`)

**Manual operation:** See "[Flatness Cal – Max Iterations](#)" on page 415

---

**SOURce<Ch>:POWer<PhyPt>:CORRection:COLLect:AVERAge:NTOLerance**  
 <Tolerance>

Specifies the maximum deviation of the measured power from the target power of the calibration. The command is valid for all channels and calibrated ports.

**Suffix:**

<Ch> Calibrated channel number. This parameter is ignored; the tolerance value is valid for all sources.

<PhyPt> Calibrated port number. This parameter is ignored; the tolerance value is valid for all sources.

**Parameters:**

<Tolerance> Tolerance value  
 Range: 0.001 dB to 1000 dB  
 \*RST: 1 dB  
 Default unit: dB

**Example:** See `SOURce<Ch>:POWer<PhyPt>:CORRection[:ACQuire]`

**Manual operation:** See "Flatness Cal – Tolerance" on page 415

**SOURce<Ch>:POWer<PhyPt>:CORRection:COLLect:CFACTOR <Convergence>**

Specifies the convergence factor for a source power calibration.

**Suffix:**

<Ch> Calibrated channel number. This parameter is ignored; the convergence factor is valid for all sources.

<PhyPt> Calibrated port number. This parameter is ignored; the convergence factor is valid for all sources.

**Parameters:**

<Convergence> Convergence factor  
 Range: 0 to 2  
 Increment: 0.1  
 \*RST: 0.8

**Example:** See `SOURce<Ch>:POWer<PhyPt>:CORRection[:ACQuire]`

**Manual operation:** See "Flatness Cal – Convergence" on page 415

**SOURce<Ch>:POWer<PhyPt>:CORRection:COLLect:FLATness <arg0>**

Enables or disables the source power calibration. The command is valid for all channels and ports.

It is not possible to disable flatness calibration and the reference receiver calibration simultaneously

(`SOURce<Ch>:POWer<PhyPt>:CORRection:COLLect:RREceiver`).

**Suffix:**

<Ch> Calibrated channel number. This parameter is ignored; the verification is either enabled or disabled for all channels.

<PhyPt> Calibrated port number. This parameter is ignored; the verification is either enabled or disabled for all sources.

**Parameters:**

&lt;arg0&gt;

Enables (ON) or disables (OFF) the flatness calibration. With disabled flatness calibration, only one calibration sweep is performed in order to calibrate the reference receiver; the previous source calibration data is not overwritten.

```
*RST: ON
```

**Example:**

```
*RST; SOUR:POW:CORR:COLL:VER 0
```

Disable the verification sweep to speed up the source power calibration procedure.

```
SOUR:POW:CORR:COLL:FLAT OFF; RREC ON
```

Disable flatness cal and enable reference receiver calibration.

```
SOUR:POW:CORR:ACQ PORT, 1
```

Perform a single source power calibration sweep using port 1 as a source port.

**SOURce<Ch>:POWER<PhyPt>:CORRection:COLLect:METHod <PowerCalMethod>**

Selects the source power calibration method.

**Suffix:**

&lt;Ch&gt;

Calibrated channel number. This parameter is ignored; the method is valid for all channels.

&lt;PhyPt&gt;

Calibrated port number. This parameter is ignored: the selected calibration method is used for all sources.

**Parameters:**

&lt;PowerCalMethod&gt; PMONly | RRAfter | RRONly

**PMONly**

Power meter only, i.e. only the power meter is used during calibration.

To enable a reference receiver and/or source flatness calibration, set `SOURce<Ch>:POWER<PhyPt>:CORRection:COLLect:RRECeiver` and/or `SOURce<Ch>:POWER<PhyPt>:CORRection:COLLect:FLATness` to ON.

**RRAfter**

First the reference receiver will be calibrated by a single power meter measurement, then the source flatness calibration will be performed using the calibrated reference receiver.

**Requires**

```
SOURce<Ch>:POWER<PhyPt>:CORRection:COLLect:FLATness ON.
```

**RRONly**

Reference receiver only. The reference receiver will be used to perform a source flatness calibration. Ideally the reference receiver was previously calibrated using a power meter.

**Requires**

```
SOURce<Ch>:POWER<PhyPt>:CORRection:COLLect:RRECeiver OFF.
```

\*RST: RRAfter

**Example:** See `SOURce<Ch>:POWER<PhyPt>:CORRection[:ACQuire]`

**Manual operation:** See "Flatness Cal – Pwr Cal Method" on page 415

### `SOURce<Ch>:POWER<PhyPt>:CORRection:COLLect:RRECeiver <arg0>`

Enables or disables calibration of the reference receiver together with the source power calibration.

**Note:** It is not possible to disable flatness calibration (`SOURce<Ch>:POWER<PhyPt>:CORRection:COLLect:FLATness`) and the reference receiver calibration simultaneously.

**Suffix:**

<Ch> Calibrated channel number. This parameter is ignored; the verification is either enabled or disabled for all channels.

<PhyPt> Calibrated port number. This parameter is ignored; the verification is either enabled or disabled for all sources.

**Parameters:**

<arg0> Enables (ON) or disables (OFF) reference receiver calibration.

\*RST: ON

**Example:** See `SOURce<Ch>:POWER<PhyPt>:CORRection:COLLect:FLATness` on page 1000.

### `SOURce:POWER:CORRection:COLLect:VNETworks <DeEmbNwType>[, <DeEmbType>]`

Defines whether the source flatness cal uses the configured offset de-/embedding to get the power values at the DUT (instead of the calibrated reference plane).

This setting applies to all physical ports and all channels.

**Parameters:**

<DeEmbNwType> SENDed | GLOop | OFF | ALL | DIFFerential | PSET | RENorm | OFFSet | AOFFset

Selects the offset or de-/embedding type to be used, if configured.

ALL means that all available offset and de-/embedding information is applied. The <DeEmbType> can be omitted in this case.

\*RST: OFF

<DeEmbType> EMBedding | DEEMBembedding

Selects between embedding and deembedding for the selected <DeEmbNwType>.

Must be specified for network types that can be used for embedding and deembedding

**Manual operation:** See "Embedding" on page 416

**SOURce<Ch>:POWER<PhyPt>:CORRection:DATA:PARAmeter<Wv>:COUNT?**

Gets the number of available power calibrations (both source power and measurement receiver).

Use `SOURce<Ch>:POWER:CORRection:DATA:PARAmeter<Wv>?` to retrieve the related settings.

**Suffix:**

<Ch>                      Number of the calibrated channel.

<PhyPt>                  This suffix is ignored.

<Wv>                      This suffix is ignored.

**Usage:**                      Query only

**Manual operation:**    See "[Port Overview](#)" on page 394

**SOURce<Ch>:POWER<PhyPt>:CORRection:NREadings <NoCalSweeps>**

Sets a limit for the number of calibration sweeps in the source power calibration. The command is valid for all channels, ports and external generators.

Equivalent command: `SOURce<Ch>:POWER<PhyPt>:CORRection:COLLect:AVERAge[:COUNT]`.

**Suffix:**

<Ch>                      Calibrated channel number. This parameter is ignored; the limit applies to all sources.

<PhyPt>                  Calibrated port number. This parameter is ignored; the limit applies to all sources.

**Parameters:**

<NoCalSweeps>          Number of readings  
                                  Range:        1 to 100  
                                  \*RST:        2

**Example:**                      See `SOURce<Ch>:POWER<PhyPt>:CORRection[:ACQuire]`

**Manual operation:**    See "[Flatness Cal – Max Iterations](#)" on page 415

**SOURce<Ch>:POWER<PhyPt>:CORRection:OSources[:STATe] <Boolean>**

Switches off all other sources during the calibration sweep for channel <Ch>.

**Suffix:**

<Ch>                      Calibrated channel number

<PhyPt>                  Calibrated port number. This parameter is ignored; the setting is valid for all sources.

**Parameters:**

<Boolean> ON - other sources not necessarily switched off.  
 OFF - other sources switched off during the calibration sweep.  
 \*RST: ON

**Example:** See [SOURCE<Ch>:POWER<PhyPt>:CORREction\[:ACquire\]](#)

**Manual operation:** See "[Switch Off Other Sources](#)" on page 415

**SOURCE:POWER:CORREction:PPOWER <RecCalPower>**

Defines the source power the R&S ZND uses to perform the first calibration sweep of the source power calibration ("Reference Receiver Cal Power"). This predefined power value is ignored if the R&S ZND is set to use the calculated port power result ([SOURCE<Ch>:POWER<PhyPt>:CORREction:PSElect CPOW](#)).

**Parameters:**

<RecCalPower> Reference receiver cal power  
 Range: Depending on source power range of the analyzer and the power range of the external power meter.  
 \*RST: 0 dBm  
 Default unit: dBm

**Example:** See [SOURCE<Ch>:POWER<PhyPt>:CORREction\[:ACquire\]](#)

**Manual operation:** See "[Reference Receiver Cal Power](#)" on page 418

**SOURCE<Ch>:POWER<PhyPt>:CORREction:PSElect <CalPower>**

Qualifies how to define the source power the R&S ZND uses to perform the first calibration sweep of the source power calibration ("Reference Receiver Cal Power").

**Suffix:**

<Ch> Calibrated channel number. This parameter is ignored; this setting applies to all channels.

<PhyPt> Calibrated port number. This parameter is ignored; this setting applies to all channels.

**Parameters:**

<CalPower> CPOWER | PPOWER  
**CPOWER**  
 Calculated port power result  
**PPOWER**  
 Predefined port power value, see [SOURCE:POWER:CORREction:PPOWER](#)  
 \*RST: CPOWER

**Example:** See [SOURCE<Ch>:POWER<PhyPt>:CORREction\[:ACquire\]](#)



**Manual operation:** See ["Reference Receiver Cal Power"](#) on page 418

---

### **SOURce<Ch>:POWER<PhyPt>:CORRection:STATe** <Boolean>

Enables or disables the source power calibration for channel <Ch> and for port number <PhyPt>. The setting command is disabled unless a source power calibration for the analyzer port has been performed ([SOURce<Ch>:POWER<PhyPt>:CORRection\[:ACQuire\]](#)). The query always returns a result.

**Suffix:**

<Ch>                      Calibrated channel number

<PhyPt>                   Calibrated port number

**Parameters:**

<Boolean>                Enables (ON) or disables (OFF) the source power calibration for port number <PhyPt>.

\*RST:                    OFF

**Example:**                See [SOURce<Ch>:POWER<PhyPt>:CORRection\[:ACQuire\]](#)

.

**Manual operation:** See ["Port Overview"](#) on page 423

---

### **SOURce<Ch>:POWER<PhyPt>:CORRection:TCOefficient[:STATe]** <Boolean>

Enables or disables the use of two-port transmission coefficients.

**Suffix:**

<Ch>                      Calibrated channel number. This parameter is ignored; the transmission coefficient settings are valid for all channels.

<PhyPt>                   Calibrated port number. This parameter is ignored; the transmission coefficient settings are valid for all sources.

**Parameters:**

<Boolean>                Enables (ON) or disables (OFF) the two-port transmission coefficients.

\*RST:                    n/a

**Example:**                See [SOURce<Ch>:POWER<PhyPt>:CORRection:TCOefficient:CALibration](#)

**Manual operation:** See ["Test Setup"](#) on page 419

---

### **SOURce<Ch>:POWER<PhyPt>:CORRection:TCOefficient:CALibration** <Boolean>

Selects the position of the additional two-port in the test setup.

**Suffix:**

<Ch>                      Calibrated channel number. This parameter is ignored; the transmission coefficient settings are valid for all channels.

<PhyPt> Calibrated port number. This parameter is ignored; the transmission coefficient settings are valid for all sources.

**Parameters:**

&lt;Boolean&gt;

ON – two port at power meter (during calibration)

OFF – two port at DUT (during measurement)

\*RST: ON (notice that the correction is switched off after a reset)

**Example:**

```
RST; :SOUR:POW:CORR:TCO:CAL OFF
```

Select the test setup with the additional two-port in front of the DUT.

```
SOUR:POW:CORR:TCO:DEF 1GHz, -5; DEF 2GHz, -10; DEF2?
```

Define two points in the power loss list; query the second point.

```
SOUR:POW:CORR:TCO:INS2 1.5 GHz, -7.5
```

Insert a third point as point no. 2 in the list.

**Example:**

```
SOUR:POW:CORR:TCO:COUN?
```

Query the number of points. The response is 3.

```
SOUR:POW:CORR:TCO ON
```

Enable the use of two-port transmission coefficients.

```
SOUR:POW:CORR:TCO:FEED 'Trc1'
```

Replace the previous 3 points by the trace points of the default trace "Trc1".

**Example:**

```
MMEM:STOR:CORR:TCO 'C:
```

```
\Users\Public\Documents\Rohde-Schwarz\Vna
```

```
\PowerMeterCorr\Test.pmcl'
```

Store the power loss list to the power meter correction list file Test.pmcl in the directory

```
C:\Users\Public\Documents\Rohde-Schwarz\Vna\PowerMeterCorr.
```

```
MMEM:LOAD:CORR:TCO 'C:\Users\Public\Documents\Rohde-Schwarz\Vna\PowerMeterCorr\Test.pmcl'
```

Re-load the stored power meter correction list file.

**Example:**

```
SOUR:POW:CORR:TCO:DEL1
```

Delete the first point in the list.

```
SOUR:POW:CORR:TCO:DEL:ALL; :SOUR:POW:CORR:TCO?
```

Clear the entire list. Query whether the transmission coefficients are still taken into account. The response is 0.

```
MMEM:LOAD:CORR:TCO 'C:\Users\Public\Documents\Rohde-Schwarz\Vna\Traces\Test.s2p', 'S21'
```

Load a power loss list from a previously created 2-port Touchstone file.

**Manual operation:** See ["Test Setup"](#) on page 419

**SOURce<Ch>:POWER<PhyPt>:CORRection:TCOefficient:COUNT?**

Queries the number of frequency values and transmission coefficients in the power loss list.

**Suffix:**

<Ch>                      Calibrated channel number. This parameter is ignored; the transmission coefficient settings are valid for all channels.

<PhyPt>                  Calibrated port number. This parameter is ignored; the transmission coefficient settings are valid for all sources.

**Example:**

See [SOURce<Ch>:POWER<PhyPt>:CORRection:TCOefficient:CALibration](#)

**Usage:**

Query only

**Manual operation:**

See "[Frequency / Transm. Coefficients: Insert, Delete, Delete All](#)" on page 420

**SOURce<Ch>:POWER<PhyPt>:CORRection:TCOefficient:DEFine<ListNo>  
<Frequency>, <TransCoeff>**

Adds a new frequency and transmission coefficient to the end of the power loss list. The query returns the frequency and transmission coefficient no. <ListNo>.

**Suffix:**

<Ch>                      Calibrated channel number. This parameter is ignored; the transmission coefficient settings are valid for all channels.

<PhyPt>                  Calibrated port number. This parameter is ignored; the transmission coefficient settings are valid for all sources.

<ListNo>                 Number of point in the list. This suffix is only used for queries.

**Parameters:**

## &lt;Frequency&gt;

Stimulus frequency value. If several points with identical frequencies are added, the analyzer automatically ensures a frequency spacing of 1 Hz.

Range:                  Stimulus values outside the frequency range of the analyzer are allowed.

\*RST:                  n/a

Default unit: Hz

## &lt;TransCoeff&gt;

Transmission coefficient

Range:                  -300 dB to +200 dB

\*RST:                  n/a

Default unit: dB

**Example:**

See [SOURce<Ch>:POWER<PhyPt>:CORRection:TCOefficient:CALibration](#)

**Manual operation:**

See "[Frequency / Transm. Coefficients: Insert, Delete, Delete All](#)" on page 420

**SOURce<Ch>:POWER<PhyPt>:CORRection:TCoefficient:DELeTe<ListNo>:ALL**

Clears the power loss list.

**Suffix:**

|          |                                                                                                                         |
|----------|-------------------------------------------------------------------------------------------------------------------------|
| <Ch>     | Calibrated channel number. This parameter is ignored; the transmission coefficient settings are valid for all channels. |
| <PhyPt>  | Calibrated port number. This parameter is ignored; the transmission coefficient settings are valid for all sources.     |
| <ListNo> | Number of point in the list. This suffix is ignored; the command deletes all points.                                    |

**Example:**

See [SOURce<Ch>:POWER<PhyPt>:CORRection:TCoefficient:CALibration](#)

**Usage:**

Event

**Manual operation:**

See "[Frequency / Transm. Coefficients: Insert, Delete, Delete All](#)" on page 420

**SOURce<Ch>:POWER<PhyPt>:CORRection:TCoefficient:DELeTe<ListNo>[:DUMMy]**

Deletes a single point no. <ListNo> in the power loss list.

**Suffix:**

|          |                                                                                                                         |
|----------|-------------------------------------------------------------------------------------------------------------------------|
| <Ch>     | Calibrated channel number. This parameter is ignored; the transmission coefficient settings are valid for all channels. |
| <PhyPt>  | Calibrated port number. This parameter is ignored; the transmission coefficient settings are valid for all sources.     |
| <ListNo> | Number of point in the list.                                                                                            |

**Example:**

See [SOURce<Ch>:POWER<PhyPt>:CORRection:TCoefficient:CALibration](#)

**Manual operation:**

See "[Frequency / Transm. Coefficients: Insert, Delete, Delete All](#)" on page 420

**SOURce<Ch>:POWER<PhyPt>:CORRection:TCoefficient:FEED <Trace>**

Selects a trace which provides the points for the power loss list.

**Suffix:**

|         |                                                                                                                         |
|---------|-------------------------------------------------------------------------------------------------------------------------|
| <Ch>    | Calibrated channel number. This parameter is ignored; the transmission coefficient settings are valid for all channels. |
| <PhyPt> | Calibrated port number. This parameter is ignored; the transmission coefficient settings are valid for all sources.     |

**Setting parameters:**

<Trace> String parameter for the trace name, e.g. 'Trc1'. The trace must exist in the active recall set.

\*RST: n/a

**Example:**

See [SOURce<Ch>:POWER<PhyPt>:CORRection:TCoefficient:CALibration](#)

**Usage:**

Setting only

**Manual operation:** See ["Get Trace..."](#) on page 420

**SOURce<Ch>:POWER<PhyPt>:CORRection:TCoefficient:INSert<ListNo>  
<Frequency>, <TransCoeff>**

Inserts a new frequency and transmission coefficient at position no. <ListNo> in the power loss list. The following points are shifted down in the list.

**Suffix:**

<Ch> Calibrated channel number. This parameter is ignored; the transmission coefficient settings are valid for all channels.

<PhyPt> Calibrated port number. This parameter is ignored; the transmission coefficient settings are valid for all sources.

<ListNo> Number of point to insert in the list.

**Parameters:**

<Frequency> Stimulus frequency value. If several points with identical frequencies are added, the analyzer automatically ensures a frequency spacing of 1 Hz.

Range: Stimulus values outside the frequency range of the analyzer are allowed.

\*RST: n/a

Default unit: Hz

<TransCoeff> Transmission coefficient

Range: -300 dB to +200 dB

\*RST: n/a

Default unit: dB

**Example:**

See [SOURce<Ch>:POWER<PhyPt>:CORRection:TCoefficient:CALibration](#)

**Manual operation:** See ["Frequency / Transm. Coefficients: Insert, Delete, Delete All"](#) on page 420

**SOURce:POWER... (Contd.)**

The `SOURce:POWER...` commands define the power of the internal signal source.

[SOURce:POWER:REDuce:SDElay](#)..... 1010

[SOURce:POWER:SWEepend:MODE](#)..... 1010

[SOURce:POWER:SWEepend:SDElay](#)..... 1010



This is a global setting.

**Parameters:**

<SettlingDelay> Settling delay  
Default unit: s

**Manual operation:** See "[Settling Delay / Reset Delay](#)" on page 529

**SOURce<Ch>:POWER<PhyPt>[:LEVel][:IMMediate][:AMPLitude]** <IntSourcePow>

Defines the power of the internal signal source (channel base power). The setting is valid for all sweep types, except power sweep.

**Tip:** Use `SOURce<Ch>:POWER<PhyPt>:START` and `SOURce<Ch>:POWER<PhyPt>:STOP` to define the sweep range for a power sweep.

**Suffix:**

<Ch> Channel number

<PhyPt> Test port number of the analyzer. This suffix is ignored because the selected channel base power applies to all source ports used in the active channel.

It is possible though to define a port-specific slope factor for the source power (`SOURce<Ch>:POWER<PhyPt>[:LEVel][:IMMediate]:SLOPe`) and a port-specific power offset (`SOURce<Ch>:POWER<PhyPt>[:LEVel][:IMMediate]:OFFSet`).

**Parameters:**

<IntSourcePow> Internal source power

Range: The usable power range is frequency-dependent; refer to the data sheet.

\*RST: -10 dBm

Default unit: dBm

**Example:**

```
FUNC "XFR:POW:RAT B1, A2"
```

Activate a frequency sweep and select the ratio B1/A2 as measured parameter for channel and trace no. 1.

```
SOUR:POW -6
```

Set the internal source power for channel 1 to -6 dBm.

**Manual operation:** See "[Power](#)" on page 347

**SOURce<Ch>:POWER<PhyPt>[:LEVel][:IMMediate]:OFFSet** <Offset>, <OffsetType>

Defines a port-specific source power or a power offset relative to the channel power (`SOURce<Ch>:POWER<PhyPt>[:LEVel][:IMMediate][:AMPLitude]`). An additional "Cal Power Offset" can be defined via `SOURce<Ch>:POWER<PhyPt>:CORRection:LEVel:OFFSet`.

**Suffix:**

<Ch> Channel number

|                          |                                                                                                                                                                                                                                                                                                                                                                           |
|--------------------------|---------------------------------------------------------------------------------------------------------------------------------------------------------------------------------------------------------------------------------------------------------------------------------------------------------------------------------------------------------------------------|
| <PhyPt>                  | Test port number of the analyzer                                                                                                                                                                                                                                                                                                                                          |
| <b>Parameters:</b>       |                                                                                                                                                                                                                                                                                                                                                                           |
| <Offset>                 | Port-specific power offset<br>Range: -300 dB to +300 dB (adjust to the analyzer's actual source power range and the test setup)<br>Increment: 0.01 dB (other values are rounded)<br>*RST: 0 dB<br>Default unit: dB                                                                                                                                                        |
| <OffsetType>             | ONLY   CPADd<br>ONLY - only the port-specific power is used; the channel power is ignored.<br>CPADd - the port-specific power is added as an offset to the channel power.<br>*RST: CPADd                                                                                                                                                                                  |
| <b>Example:</b>          | *RST; SOUR:POW -6<br>Reset the instrument, activating a frequency sweep and set the internal source power (channel power) for the default channel 1 to -6 dBm.<br>SOUR:POW1:OFFS 6, ONLY; SOUR:POW2:OFFS 6, CPAD<br>Replace the source power at port 1 by +6 dBm, the source power at port 2 by 0 dBm. The powers at the remaining ports (if available) are not affected. |
| <b>Manual operation:</b> | See " <a href="#">Port Overview</a> " on page 417                                                                                                                                                                                                                                                                                                                         |

---

### SOURce<Ch>:POWER<PhyPt>[:LEVel][:IMMediate]:SLOPe <Slope>

Defines a linear factor to modify the internal source power at port <PhyPt> as a function of the stimulus frequency.

**Suffix:**

|         |                                  |
|---------|----------------------------------|
| <Ch>    | Channel number                   |
| <PhyPt> | Test port number of the analyzer |

**Parameters:**

|         |                                                                                                                                                                                                                                                                      |
|---------|----------------------------------------------------------------------------------------------------------------------------------------------------------------------------------------------------------------------------------------------------------------------|
| <Slope> | Port-specific slope factor<br>Range: -40 dB/GHz to +40 dB/GHz. The resulting power range over the entire frequency sweep must be within the power range of the analyzer; refer to the data sheet.<br>Increment: 0.1-dB/GHz<br>*RST: 0 dB/GHz<br>Default unit: DB/GHZ |
|---------|----------------------------------------------------------------------------------------------------------------------------------------------------------------------------------------------------------------------------------------------------------------------|

**Example:** See `SOURce<Ch>:POWER<PhyPt>[:LEVel][:IMMediate][:AMPLitude]`



**SOURce<Ch>:POWer<PhyPt>:CORRection:LEVel:OFFSet <Offset>**

Specifies a gain (positive values) or an attenuation (negative values) in the signal path between the source port and the calibrated reference plane. The value has no impact on the source power.

**Suffix:**

<Ch>                      Calibrated channel number  
 <PhyPt>                  Calibrated port number

**Parameters:**

<Offset>                  Gain or attenuation value  
 Range:                  -300 dB to +300 dB (adjust to the test setup)  
 Increment:              0.01 dB (other values are rounded)  
 \*RST:                    0 dB  
 Default unit: dB

**Example:**

Assume that a DUT requires a constant input power of +35 dBm at port 2, and that the measurement path contains an amplifier with a 30 dB gain.

```
*RST; SOUR:POW 0
```

Reset the instrument and set the internal source power (base channel power) for the default channel 1 to 0 dBm.

```
SOUR:POW2:OFFS 5, ONLY
```

Replace the source power at port 2 by +5 dBm. The powers at the remaining ports are not affected.

```
SOUR:POW2:CORR:LEV:OFFS 30
```

Specify the gain of the amplifier in the signal path between the analyzer port 2 and the input port of the DUT.

```
SOUR:POW:CORR:ACQ PORT, 2
```

Perform a source power calibration using port 2 as a source port and the target power of +35 dBm.

**Manual operation:** See "[Port Overview](#)" on page 417

**SOURce<Ch>:POWer<PhyPt>:REDuce[:STATe] <ReduceAtSweepEnd>**

**Deprecated;** superseded by [SOURce:POWer:SWEpend:MODE](#)

Enables/disables power reduction at sweep end.

This is a global setting.

**Suffix:**

<Ch>                      Channel number. This suffix is ignored; the setting is valid for all channels.  
 <PhyPt>                  Physical port number. This suffix is ignored; the setting is valid for all ports.

**Parameters:**

<ReduceAt  
SweepEnd>

**OFF** (default): at sweep end the output power of the sweep start is restored

**ON**: at sweep end the output power of the driving port is reduced as if the channel base power was set to its minimum possible value

**Example:**

See `SOURce:POWer:SWEpend:MODE`.

`REDuce:STATE OFF` is equivalent to `SWEpend:MODE AUTO`

`REDuce:STATE ON` is equivalent to `SWEpend:MODE REDuce`

**SOURce<Ch>:POWER<PhyPt>:STATe <Boolean>**

Turns the RF source power at a specified test port on or off.

**Suffix:**

<Ch> Channel number

<PhyPt> Test port number of the analyzer

**Parameters:**

<Boolean>

ON | OFF - turns the internal source power at the specified test port no. <PhyPt> on or off.

\*RST: ON

**Example:**

\*RST; SOUR:POW -6

Set the internal source power for channel 1 and all test ports to -6 dBm.

`SOUR:POW2:STAT?`

Query whether the source power at test port 2 is on. The analyzer returns a 1.

**SOURce<Ch>:POWER<PhyPt>:START <StartPower>****SOURce<Ch>:POWER<PhyPt>:STOP <StopPower>**

These commands define the start and stop powers for a power sweep. The values also define the left and right edges of a Cartesian diagram. A power sweep must be active (`[SENSe<Ch>:]SWEep:TYPE POWer`) to use these commands.

**Suffix:**

<Ch> Channel number

<PhyPt> Test port number of the analyzer. This suffix is ignored because the selected power sweep range applies to all source ports used in the active channel.

**Parameters:**

<StopPower> Start or stop power of the sweep.  
 Range: -150 dBm to +100 dBm. The usable power range is frequency-dependent; refer to the data sheet.  
 Increment: 0.01 dB  
 \*RST: -25 dBm start power, 0 dBm stop power  
 Default unit: dBm

**Example:**

```
SWE:TYPE POW
Activate a power sweep.
SOUR:POW:STAR -6; STOP 10
Select a power sweep range between -6 dBm and +10 dBm.
```

**Manual operation:** See "Start Power / Stop Power" on page 347

**Note:** If the start power entered is greater than the current stop power (SOURce<Ch>:POWer<PhyPt>:STOP), the stop power is set to the start power plus the minimum power span (increment) of 0.01 dB.

If the stop power entered is smaller than the current start power (SOURce<Ch>:POWer<PhyPt>:START), the start power is set to the stop power minus the minimum power span of 0.01 dB.

### 8.3.16 STATus Commands

The STATus: . . . commands control the status reporting system. Status registers are not reset by \*RST; use \*CLS for this purpose.

|                                                         |      |
|---------------------------------------------------------|------|
| STATus:PRESet.....                                      | 1016 |
| STATus:QUESTionable[:EVENT]?                            | 1016 |
| STATus:QUESTionable:INTegrity[:EVENT]?                  | 1016 |
| STATus:QUESTionable:INTegrity:HARDware[:EVENT]?         | 1016 |
| STATus:QUESTionable:LIMit<Lev>[:EVENT]?                 | 1016 |
| STATus:QUESTionable:CONDition?                          | 1016 |
| STATus:QUESTionable:INTegrity:CONDition?                | 1016 |
| STATus:QUESTionable:INTegrity:HARDware:CONDition?       | 1016 |
| STATus:QUESTionable:LIMit<Lev>:CONDition?               | 1016 |
| STATus:QUESTionable:ENABLE.....                         | 1017 |
| STATus:QUESTionable:INTegrity:ENABLE.....               | 1017 |
| STATus:QUESTionable:INTegrity:HARDware:ENABLE.....      | 1017 |
| STATus:QUESTionable:LIMit<Lev>:ENABLE.....              | 1017 |
| STATus:QUESTionable:NTRansition.....                    | 1017 |
| STATus:QUESTionable:INTegrity:NTRansition.....          | 1017 |
| STATus:QUESTionable:INTegrity:HARDware:NTRansition..... | 1017 |
| STATus:QUESTionable:LIMit<Lev>:NTRansition.....         | 1017 |
| STATus:QUESTionable:PTRansition.....                    | 1018 |
| STATus:QUESTionable:INTegrity:PTRansition.....          | 1018 |
| STATus:QUESTionable:INTegrity:HARDware:PTRansition..... | 1018 |
| STATus:QUESTionable:LIMit<Lev>:PTRansition.....         | 1018 |
| STATus:QUEue[:NEXT]?                                    | 1018 |

**STATus:PRESet**

Configures the status reporting system such that device-dependent events are reported at a higher level.

The command affects only the transition filter registers, the `ENABLE` registers, and queue enabling:

- The `ENABLE` parts of the `STATus:OPERation` and `STATus:QUEStionable...` registers are set to all 1's.
- The `PTRansition` parts are set all 1's, the `NTRansition` parts are set to all 0's, so that only positive transitions in the `CONDition` part are recognized.

The status reporting system is also affected by other commands, see [Chapter 7.5.5, "Reset Values of the Status Reporting System"](#), on page 592.

**Example:**                    `STAT:PRES`  
Preset the status registers.

**Usage:**                    Event

**STATus:QUEStionable[:EVENT]?****STATus:QUEStionable:INTEgrity[:EVENT]?****STATus:QUEStionable:INTEgrity:HARDware[:EVENT]?****STATus:QUEStionable:LIMit<Lev>[:EVENT]?**

These commands return the contents of the `EVENT` parts of the `QUEStionable`, `QUEStionable:INTEgrity`, `QUEStionable:INTEgrity:HARDware`, and `QUEStionable:LIMit<Lev>` status registers. Reading an `EVENT` register clears it.

**Suffix:**  
<Lev>                    Selects one of the two `QUEStionable:LIMit` registers; see ["STATus:QUEStionable:LIMit<1|2>"](#) on page 586.

**Example:**                    `STAT:QUES:LIM1?`  
Query the `EVENT` part of the `QUEStionable:LIMit1` register to check whether an event has occurred since the last reading.

**Usage:**                    Query only

**STATus:QUEStionable:CONDition?****STATus:QUEStionable:INTEgrity:CONDition?****STATus:QUEStionable:INTEgrity:HARDware:CONDition?****STATus:QUEStionable:LIMit<Lev>:CONDition?**

Returns the contents of the `CONDition` part of the `QUEStionable...` registers. Reading the `CONDition` registers is nondestructive.

**Suffix:**  
<Lev>                    Selects one of the two `QUEStionable:LIMit` registers; see ["STATus:QUEStionable:LIMit<1|2>"](#) on page 586.

**Example:** `STAT:QUES:LIMit:COND?`  
Query the `CONDition` part of the `QUESTionable:LIMit1` register to retrieve the current status of the limit check.

**Usage:** Query only

**STATus:QUESTionable:ENABLE** <BitPattern>

**STATus:QUESTionable:INTEgrity:ENABLE** <BitPattern>

**STATus:QUESTionable:INTEgrity:HARDware:ENABLE** <BitPattern>

**STATus:QUESTionable:LIMit<Lev>:ENABLE** <BitPattern>

Sets the enable mask which allows true conditions in the `EVENT` part of the `QUESTionable...` registers to be reported in the summary bit. If a bit is 1 in the enable register and its associated event bit transitions to true, a positive transition will occur in the summary bit (e.g. bit 10 of the `QUESTionable` register for the `LIMit1` register, bit 0 of the `LIMit1` register for the `LIMit2` register).

See also [Chapter 7.5.1, "Overview of Status Registers"](#), on page 581 and [Chapter 7.5.5, "Reset Values of the Status Reporting System"](#), on page 592.

**Suffix:**

<Lev> Selects one of the two `QUESTionable:LIMit` registers; see "[STATus:QUESTionable:LIMit<1|2>](#)" on page 586.

**Parameters:**

<BitPattern> Range: 0 to 65535 (decimal representation)  
\*RST: n/a

**Example:** `STAT:QUES:LIM2:ENAB 6`  
Set bits no. 1 and 2 of the `QUESTionable:LIMit2:ENABLE` register

**STATus:QUESTionable:NTRansition** <BitPattern>

**STATus:QUESTionable:INTEgrity:NTRansition** <BitPattern>

**STATus:QUESTionable:INTEgrity:HARDware:NTRansition** <BitPattern>

**STATus:QUESTionable:LIMit<Lev>:NTRansition** <BitPattern>

Sets the negative transition filters of the `QUESTionable...` status registers. If a bit is set, a 1 to 0 transition in the corresponding bit of the associated condition register causes a 1 to be written in the associated bit of the corresponding event register.

**Suffix:**

<Lev> Selects one of the two `QUESTionable:LIMit` registers; see "[STATus:QUESTionable:LIMit<1|2>](#)" on page 586.

**Parameters:**

<BitPattern> Range: 0 to 65535 (decimal representation)  
\*RST: n/a

**Example:** `STAT:QUES:LIM2:NTR 6`  
Set bits no. 1 and 2 of the `QUESTionable:LIMit2:NTRansition` register

---

**STATus:QUESTionable:PTRansition** <BitPattern>

**STATus:QUESTionable:INTEgrity:PTRansition** <BitPattern>

**STATus:QUESTionable:INTEgrity:HARDware:PTRansition** <BitPattern>

**STATus:QUESTionable:LIMit<Lev>:PTRansition** <BitPattern>

Configures the positive transition filters of the `QUESTionable...` status registers. If a bit is set, a 0 to 1 transition in the corresponding bit of the associated condition register causes a 1 to be written in the associated bit of the corresponding event register.

See also [Chapter 7.5.5, "Reset Values of the Status Reporting System"](#), on page 592.

**Suffix:**

<Lev>                      Selects one of the two `QUESTionable:LIMit` registers; see ["STATus:QUESTionable:LIMit<1|2>"](#) on page 586.

**Parameters:**

<BitPattern>              Range:        0 to 65535 (decimal representation)  
                               \*RST:        n/a

**Example:**

`STAT:QUES:LIM2:PTR 6`  
 Set bits no. 1 and 2 of the  
`QUESTionable:LIMit2:PTRansition` register

---

**STATus:QUEue[:NEXT]?**

Queries and at the same time deletes the oldest entry in the error queue. Operation is identical to that of [SYSTEM:ERRor\[:NEXT\]?](#)

The entry consists of an error number and a short description of the error. Positive error numbers are instrument-dependent. Negative error numbers are reserved by the SCPI standard; see section [Chapter 10, "Error Messages and Troubleshooting"](#), on page 1143.

**Example:**

`STAT:QUE?`  
 Query the oldest entry in the error queue. 0, "No error" is returned if the error queue is empty.

**Usage:**

Query only

## 8.3.17 SYSTEM Commands

The `SYSTEM...` commands provide functions that are not related to instrument performance, such as functions for general housekeeping and functions related to global configurations.

### 8.3.17.1 SYSTEM:COMMunicate...

The `SYSTEM:COMMunicate...` commands provide remote control settings and configure remote (external) devices controlled by the R&S ZND.

|                                                                    |      |
|--------------------------------------------------------------------|------|
| SYSTem:COMMunicate:AKAL:CONNEction.....                            | 1019 |
| SYSTem:COMMunicate:AKAL:MMEMory[:STATe].....                       | 1020 |
| SYSTem:COMMunicate:CODeC.....                                      | 1020 |
| SYSTem:COMMunicate:GPIB[:SELF]:ADDReSS.....                        | 1021 |
| SYSTem:COMMunicate:GPIB[:SELF]:DCLeAr:SUppReSS.....                | 1021 |
| SYSTem:COMMunicate:GPIB[:SELF]:INIT:WAIT.....                      | 1021 |
| SYSTem:COMMunicate:GPIB[:SELF]:LPORt:ALIGn.....                    | 1021 |
| SYSTem:COMMunicate:GPIB[:SELF]:RTERminator.....                    | 1022 |
| SYSTem:COMMunicate:NET:HOSTName.....                               | 1022 |
| SYSTem:COMMunicate:RDEVice:AKAL:ADDReSS.....                       | 1023 |
| SYSTem:COMMunicate:RDEVice:AKAL:ADDReSS:ALL?.....                  | 1023 |
| SYSTem:COMMunicate:RDEVice:AKAL:CKIT:CATalog?.....                 | 1023 |
| SYSTem:COMMunicate:RDEVice:AKAL:CKIT:STANdard:CATalog?.....        | 1024 |
| SYSTem:COMMunicate:RDEVice:AKAL:DATE?.....                         | 1025 |
| SYSTem:COMMunicate:RDEVice:AKAL:FRANge?.....                       | 1025 |
| SYSTem:COMMunicate:RDEVice:AKAL:PORtS?.....                        | 1026 |
| SYSTem:COMMunicate:RDEVice:AKAL:PREdUction[:STATe].....            | 1026 |
| SYSTem:COMMunicate:RDEVice:AKAL:SDATa?.....                        | 1026 |
| SYSTem:COMMunicate:RDEVice:AKAL:WARMup[:STATe]?.....               | 1027 |
| SYSTem:COMMunicate:RDEVice:PMETer:CATalog?.....                    | 1027 |
| SYSTem:COMMunicate:RDEVice:PMETer:CONFigure:AUTO[:STATe].....      | 1028 |
| SYSTem:COMMunicate:RDEVice:PMETer:COUNT?.....                      | 1028 |
| SYSTem:COMMunicate:RDEVice:PMETer:DELeTe.....                      | 1028 |
| SYSTem:COMMunicate:RDEVice:PMETer<Pmtr>:AZERo.....                 | 1029 |
| SYSTem:COMMunicate:RDEVice:PMETer<Pmtr>:DEFine.....                | 1029 |
| SYSTem:COMMunicate:RDEVice:PMETer<Pmtr>:SPCorreCtion[:STATe].....  | 1030 |
| SYSTem:COMMunicate:RDEVice:SMATrix<Matr>:CATalog?.....             | 1030 |
| SYSTem:COMMunicate:RDEVice:SMATrix<Matr>:CONFigure:ABORt.....      | 1031 |
| SYSTem:COMMunicate:RDEVice:SMATrix<Matr>:CONFigure:END.....        | 1031 |
| SYSTem:COMMunicate:RDEVice:SMATrix<Matr>:CONFigure:STARt.....      | 1032 |
| SYSTem:COMMunicate:RDEVice:SMATrix<Matr>:CONFigure:TVNA.....       | 1033 |
| SYSTem:COMMunicate:RDEVice:SMATrix<Matr>:COUNT?.....               | 1033 |
| SYSTem:COMMunicate:RDEVice:SMATrix<Matr>:DELeTe.....               | 1033 |
| SYSTem:COMMunicate:RDEVice:SMATrix<Matr>:SCAN?.....                | 1033 |
| SYSTem:COMMunicate:RDEVice:SMATrix<Matr>:DEFine.....               | 1034 |
| SYSTem:COMMunicate:RDEVice:SMATrix<Matr>:CONFigure:MLVNa.....      | 1035 |
| SYSTem:COMMunicate:RDEVice:SMATrix<Matr>:CONFigure:MLTeSt.....     | 1035 |
| SYSTem:COMMunicate:RDEVice:SMATrix<Matr>:CONFigure:MTESt.....      | 1036 |
| SYSTem:COMMunicate:RDEVice:SMATrix<Matr>:CONFigure:MVNA.....       | 1036 |
| SYSTem:COMMunicate:RDEVice:SMATrix<Matr>:RELays:SWITCh:COUNT?..... | 1037 |
| SYSTem:COMMunicate:RDEVice:SMATrix<Matr>:SERial?.....              | 1037 |

---

**SYSTem:COMMunicate:AKAL:CONNEction** <CalStandard>, <Port>[,  
<SecondPort>[, <CalkitIndex>]]

Connects the selected calibration standard to one or two ports of the active calibration unit (see [SYSTem:COMMunicate:RDEVice:AKAL:ADDReSS](#)).

**Setting parameters:**

|               |                                                                                                                                                                                                                                                                        |
|---------------|------------------------------------------------------------------------------------------------------------------------------------------------------------------------------------------------------------------------------------------------------------------------|
| <CalStandard> | THRough   OPEN   SHORt   MATCh<br>Connected one or two-port standard                                                                                                                                                                                                   |
| <Port>        | Port number of the calibration unit, for one and two-port standards.                                                                                                                                                                                                   |
| <SecondPort>  | Second port number of the calibration unit.<br>For two-port standards (THRough) this parameter must be provided, for one-port standards (OPEN   SHORt   MATCh) it must be omitted.                                                                                     |
| <CalkitIndex> | For calibration units that are equipped with more than one calibration kit, this parameter indicates the 1-based index of the cal kit to be used (mandatory!).<br>For other calibration units, this parameter is optional, but if it is provided, it must be set to 1. |

**Example:**

```
SYST:COMM:AKAL:CONN THR, 1, 2
```

Connect a through standard between ports 1 and 2 of the cal unit.

**Usage:**

Setting only

**Manual operation:** See "[Apply/Cancel](#)" on page 384

**SYSTem:COMMunicate:AKAL:MMEMory[:STATe]** <Boolean>

Shows or hides the memory of the active calibration unit (see [SYSTem:COMMunicate:RDEvice:AKAL:ADDRess](#)).

**Setting parameters:**

|           |                                                                         |
|-----------|-------------------------------------------------------------------------|
| <Boolean> | ON - memory is shown in a separate drive.<br>OFF - memory is not shown. |
| *RST:     | OFF                                                                     |

**Example:**

```
SYST:COMM:AKAL:MMEM ON
```

Show the memory of the active calibration unit.

**Usage:**

Setting only

**Manual operation:** See "[Apply/Cancel](#)" on page 384

**SYSTem:COMMunicate:CODec** <Codec>

Selects the character encoding used at the remote interface. The selected encoding applies to directory and file names, CalKit names, CalUnit characterizations and display titles.

**Parameters:**

|         |                                    |
|---------|------------------------------------|
| <Codec> | ASCIi   UTF8   SJIS                |
|         | <b>ASCIi:</b> 8-bit ANSI (default) |
|         | <b>UTF8:</b> UTF-8                 |
|         | <b>SJIS:</b> Shift JIS             |



**Manual operation:** See ["Remote Encoding"](#) on page 518

---

**SYSTem:COMMunicate:GPIB[:SELF]:ADDRess** <GBIBAddress>

Sets the GPIB address of the analyzer.

**Parameters:**

<GBIBAddress> GPIB address (integer number)  
Range: 0 to 30

**Example:**

```
SYST:COMM:GPIB:ADDR 10
```

Set the GPIB address to 10.

```
*RST; :SYST:COMM:GPIB:ADDR?
```

After a reset, the address is maintained (the response is 10).

**Manual operation:** See ["GPIB Address"](#) on page 539

---

**SYSTem:COMMunicate:GPIB[:SELF]:DCLear:SUPPpress** <Boolean>

Suppresses/unsuppresses of Device Clear GPIB interface messages (DCL, SDC).

**Parameters:**

<Boolean>

**Manual operation:** See ["GPIB Address"](#) on page 539

---

**SYSTem:COMMunicate:GPIB[:SELF]:INIT:WAIT** <Boolean>

Determines/queries the execution behavior of `INITiate[:IMMEDIATE]` commands (see [Chapter 8.3.8, "INITiate Commands"](#), on page 835).

If set to ON, an automatic `*WAI` is added (see [Chapter 8.2, "Common Commands"](#), on page 596), i.e. the commands execute synchronously.

**Parameters:**

<Boolean> \*RST: OFF

**Manual operation:** See ["Advanced ..."](#) on page 541

---

**SYSTem:COMMunicate:GPIB[:SELF]:LPORt:ALIGn** <Boolean>

Configures/queries the logical port creation.

If set to ON, logical ports are aligned and must be set from low to high port, which was the only possibility prior to firmware V1.90. If set to OFF, new ports can be created freely, like in manual operation. See the example below.

**Parameters:**

<Boolean> \*RST: ON

**Example:** Starting with a 4-port analyzer's default logical port assignment L1<-->P1, L2<-->P2, L3<-->P3, L4<-->P4, the remote command  
`SOUR:LPOR1 1,2`  
 by default (`ALIGn=ON`) generates aligned logical ports L1<-->P1&P2, L2<-->P3, L3<-->P4.  
 With `ALIGn=OFF`, the result is L1<-->P1&P2, L3<-->P3, L4<-->P4 and L2 does not exist.

**Manual operation:** See "[Advanced ...](#)" on page 541

### **SYSTem:COMMunicate:GPIB[:SELf]:RTERminator** <Terminator>

Sets the receive terminator of the analyzer. The receive terminator indicates the end of a command or a data block.

The receive terminator setting is relevant if block data is transferred to the analyzer (`FORMat[:DATA] REAL`). In the default setting `LFEoi`, the analyzer recognizes an LF character sequence with or without the EOI control bus message as a receive terminator. An accidental LF in a data block can be recognized as a terminator and cause an interruption of the data transfer.

The EOI setting is especially important if commands are transferred in block data format, because it ensures that the parser for command decoding is activated by the terminator only after the command has been completely transferred. Readout of binary data does not require a change of the receive terminator.

**Note:** since firmware V2.80 this command raises an error if no GPIB interface (option R&S ZND-B10) is available.

#### **Parameters:**

<Terminator> LFEoi | EOI

#### **LFEoi**

A line feed character sequence with or without EOI is recognized as receive terminator

#### **EOI**

Only EOI is recognized as receive terminator

**Example:** `SYST:COMM:GPIB:RTER EOI`  
 Set the terminator to EOI.

### **SYSTem:COMMunicate:NET:HOSTname** <HostName>

Sets or gets the host name of the instrument.

#### **Parameters:**

<HostName> Host name

\*RST: A preset of the instrument doesn't change the host name.

**SYSTem:COMMunicate:RDEvice:AKAL:ADDRess <Address>**

Selects one of the USB-connected calibration units for calibration (see commands `SENSe<Ch>:CORRection:COLLect:AUTO...`). This command is not necessary if only one cal unit is connected.

**Parameters:**

**<Address>** Name (USB address) of a connected calibration unit (string variable). The names of all connected cal units can be queried using `SYSTem:COMMunicate:RDEvice:AKAL:ADDRess:ALL?`.

**Example:**

```
SYST:COMM:RDEV:AKAL:ADDR:ALL?
```

Query the names of all connected calibration units.

```
SYST:COMM:RDEV:AKAL:ADDR 'ZV-Z52::1234'
```

Select the cal unit named 'ZV-Z52::1234' for calibration.

```
CORR:COLL:AUTO '', 1, 2, 4
```

Perform an automatic 3-port TOSM calibration at test ports 1, 2, and 4 using the calibration unit's default calibration kit file and arbitrary test ports of the cal unit.

**Manual operation:** See "[Cal Unit](#)" on page 378

**SYSTem:COMMunicate:RDEvice:AKAL:ADDRess:ALL?**

Queries the names (USB addresses) of all connected calibration units.

**Example:** See `SYSTem:COMMunicate:RDEvice:AKAL:ADDRess`

**Usage:** Query only

**Manual operation:** See "[Cal Unit](#)" on page 378

**SYSTem:COMMunicate:RDEvice:AKAL:CKIT:CATalog?**

Queries all characterizations (cal kit files) which are stored on the connected calibration unit, either on the calibration unit's internal (flash) memory or on an SD card inserted at the calibration unit (prefix: "SD"). A possible response is

'Factory,ZN-Z51\_custom,Throughs,SD:test'. The factory characterization is always available; an empty string denotes that no calibration unit is connected.

If several cal units are USB-connected to the analyzer, the command queries the cal unit selected via `SYSTem:COMMunicate:RDEvice:AKAL:ADDRess`.

**Example:**

```
SYST:COMM:RDEV:AKAL:ADDR:ALL?
```

Query the names of all connected calibration units.

```
SYST:COMM:RDEV:AKAL:ADDR 'ZN-Z51::1234'
```

Select the cal unit named 'ZN-Z51::1234'.

```
SYSTem:COMMunicate:RDEvice:AKAL:CKIT:CATalog?
```

Query all characterizations stored on the connected calibration unit.

```
SYSTem:COMMunicate:RDEvice:AKAL:SDATa?
```

```
'My_calkit', OPEN, S11, 1
```

Query the characterization data for the characterization named 'My\_calkit' and an open standard (one-port, port restriction). A characterization with the queried properties must be available on the cal unit.

```
SYSTem:COMMunicate:RDEvice:AKAL:WARMup?
```

Query the warmup status of the calibration unit.

```
SYSTem:COMMunicate:RDEvice:AKAL:DATE? 'Factory'
```

Query the creation date of the factory calibration.

```
SYSTem:COMMunicate:RDEvice:AKAL:FRANge?
```

```
'Factory'
```

Query the frequency range of the factory calibration.

```
SYSTem:COMMunicate:RDEvice:AKAL:PORTs?
```

```
'Factory'
```

Query the port assignment of the factory calibration.

```
SYSTem:COMMunicate:RDEvice:AKAL:CKIT:STANdard:CATalog? 'Factory'
```

Query the standards of the factory calibration. Possible response:

```
'MOP (P1) , MSH (P1) , MMT (P1) , MOP (P2) , MSH (P2) ,
```

```
MMT (P2) ' – denotes an Open (m), Short (m) and Match (m)
```

standard at each of the ports 1 and 2.

**Usage:**

Query only

**Manual operation:** See "[Characterization](#)" on page 379

---

**SYSTem:COMMunicate:RDEvice:AKAL:CKIT:STANdard:CATalog? <CalKitName>**

Queries all calibration standards of a characterization (calkit file) that is stored on a connected calibration unit, either on the calibration unit's internal (flash) memory or on an SD card inserted at the calibration unit (if available). The query [SYSTem:COMMunicate:RDEvice:AKAL:CKIT:CATalog?](#) returns the names of the cal kit files. The factory characterization is always available.

**Query parameters:**

<CalKitName>

Name of the calkit file, string parameter.

'Factory' denotes the factory characterization, the prefix

"SD:" indicates that the characterization is stored on an SD card inserted at the calibration unit.

**Example:**

See [SYSTem:COMMunicate:RDEvice:AKAL:CKIT:CATalog?](#)

**Usage:** Query only

**Manual operation:** See "[Characterization](#)" on page 379

#### **SYSTem:COMMunicate:RDEvice:AKAL:DATE?** <CalKitName>

Queries the creation date and time of the cal unit characterization (calkit file) <CalKitName>. A possible response is 'Friday, May 26, 2011, 10:13:40'. An empty string is returned if no calibration unit is connected.

If several cal units are USB-connected to the analyzer, the command queries the cal unit selected via [SYSTem:COMMunicate:RDEvice:AKAL:ADDRESS](#).

#### **Query parameters:**

**CalKitName** String parameter containing the name of a cal unit characterization (calkit file).  
'Factory' denotes the factory characterization; an empty string ' ' refers to the last referenced characterization; the prefix "SD:" indicates that the characterization is stored on an SD card inserted at the calibration unit.

**Example:** See [SYSTem:COMMunicate:RDEvice:AKAL:CKIT:CATalog?](#)

**Usage:** Query only

**Manual operation:** See "[Characterization](#)" on page 379

#### **SYSTem:COMMunicate:RDEvice:AKAL:FRANge?** <CalKitName>

Queries the frequency range of the cal unit characterization (calkit file) <CalKitName>. The response consists of the start and stop frequencies in Hz, separated by a comma. 0,0 is returned if no calibration unit is connected.

If several cal units are USB-connected to the analyzer, the command queries the cal unit selected via [SYSTem:COMMunicate:RDEvice:AKAL:ADDRESS](#).

#### **Query parameters:**

**<CalKitName>** String parameter containing the name of a cal unit characterization (calkit file).  
'Factory' denotes the factory characterization; an empty string ' ' denotes the last referenced characterization; the prefix "SD:" indicates that the characterization is stored on an SD card inserted at the calibration unit.

**Example:** See [SYSTem:COMMunicate:RDEvice:AKAL:CKIT:CATalog?](#)

**Usage:** Query only

**Manual operation:** See "[Characterization](#)" on page 379

**SYSTem:COMMunicate:RDEvice:AKAL:PORTs? <CalKitName>**

Queries the number of ports of a cal unit characterization (calkit file) <CalKitName>, the assigned connector types, and their gender. A possible response for a two-port calibration is '1,N 50 Ohm,MALE,2,N 50 Ohm,MALE'. An empty string is returned if no calibration unit is connected.

If several cal units are USB-connected to the analyzer, the command queries the cal unit selected via [SYSTem:COMMunicate:RDEvice:AKAL:ADDResS](#).

**Query parameters:**

<CalKitName> String parameter containing the name of a cal unit characterization (calkit file).  
'Factory' denotes the factory characterization; an empty string ' ' denotes the last referenced characterization; the prefix "SD:" indicates that the characterization is stored on an SD card inserted at the calibration unit.

**Example:** See [SYSTem:COMMunicate:RDEvice:AKAL:CKIT:CATalog?](#)

**Usage:** Query only

**Manual operation:** See "[Characterization](#)" on page 379

**SYSTem:COMMunicate:RDEvice:AKAL:PREduction[:STATe] <Boolean>**

Enables or disables automatic power reduction at all test ports while an automatic calibration is active.

**Parameters:**

<Boolean> Power reduction enabled or disabled.  
\*RST: ON

**Example:** [SYSTem:COMMunicate:RDEvice:AKAL:PREduction OFF](#)  
Disable automatic power reduction.

**Manual operation:** See "[Auto Power Setting for Cal Unit](#)" on page 521

**SYSTem:COMMunicate:RDEvice:AKAL:SDATa? <CalKitName>, <Type>, <SParameter>[, <FirstPort>, <SecondPort>]**

Reads the calibration data for a particular standard from a cal unit characterization (calkit file). If more than one calibration unit is connected, the related one must be selected using [SYSTem:COMMunicate:RDEvice:AKAL:ADDResS](#).

**Query parameters:**

<CalKitName> String parameter containing the name of a cal unit characterization (calkit file).  
'Factory' denotes the factory characterization; an empty string ' ' denotes the last referenced characterization; the prefix "SD:" indicates that the characterization is stored on an SD card inserted at the calibration unit.

|                          |                                                                                                                                                                                                                                                                                                                                                                                                                                                                                                                                                                                                                        |
|--------------------------|------------------------------------------------------------------------------------------------------------------------------------------------------------------------------------------------------------------------------------------------------------------------------------------------------------------------------------------------------------------------------------------------------------------------------------------------------------------------------------------------------------------------------------------------------------------------------------------------------------------------|
| <Type>                   | <p>THRough   OPEN   SHORt   MATCh   MMThrougH   MFThrougH   FFThrougH   MOPen   FOPen   MSHort   FSHort   MMTCh   FMTCh</p> <p>Standard types; for a description refer to table <a href="#">Standard types and their parameters</a>. The standard types of a particular characterization can be queried via <code>SYSTem:COMMunicate:RDEvice:AKAL:CKIT:STANdard:CATalog?</code>.</p> <p>The factory characterization usually does not contain data for a through standard; therefore a query of the type <code>SYSTem:COMMunicate:RDEvice:AKAL:SDATa?'Factory', THR, S11, 1, 2</code> results in an error message.</p> |
| <SParameter>             | <p>S11   S12   S21   S22</p> <p>S-parameter of the standard, use <code>S11</code> for one-port standards, one of the four for 2-port standards.</p>                                                                                                                                                                                                                                                                                                                                                                                                                                                                    |
| <FirstPort>              | <p>First port number (sufficient for one-port standards). Port numbers can be omitted if the cal kit data is valid for all ports; see <code>MMEMory:LOAD:CKIT:SDATa</code>.</p>                                                                                                                                                                                                                                                                                                                                                                                                                                        |
| <SecondPort>             | <p>Second port number, for two-port standards. Port numbers can be omitted if the cal kit data is valid for all ports.</p>                                                                                                                                                                                                                                                                                                                                                                                                                                                                                             |
| <b>Example:</b>          | <p>See <code>SYSTem:COMMunicate:RDEvice:AKAL:CKIT:CATalog?</code></p>                                                                                                                                                                                                                                                                                                                                                                                                                                                                                                                                                  |
| <b>Usage:</b>            | <p>Query only</p>                                                                                                                                                                                                                                                                                                                                                                                                                                                                                                                                                                                                      |
| <b>Manual operation:</b> | <p>See "<a href="#">Characterization</a>" on page 379</p>                                                                                                                                                                                                                                                                                                                                                                                                                                                                                                                                                              |

---

#### **SYSTem:COMMunicate:RDEvice:AKAL:WARMup[:STATe]?**

Queries the warmup state of the connected calibration unit R&S ZV\_Z5x. If several cal units are USB-connected to the analyzer, the command queries the cal unit selected via `SYSTem:COMMunicate:RDEvice:AKAL:ADDRes`.

Possible responses are 1 (true, if the calibration unit has been connected for a sufficient time to reach its operating temperature) or 0 (false). 0 is also returned if no calibration unit is connected.

**Example:** See `SYSTem:COMMunicate:RDEvice:AKAL:CKIT:CATalog?`

**Usage:** Query only

**Manual operation:** See "[Characterization](#)" on page 379

---

#### **SYSTem:COMMunicate:RDEvice:PMETer:CATalog?**

Queries the numbers of all configured external power meters. The response is a string containing a comma-separated list of power meter numbers.

**Example:**            `SYST:COMM:RDEV:PMET1:DEF 'USB Power Meter 1',`  
                           `'NRP-Z55', 'usb', '100045'`  
                           `SYST:COMM:RDEV:PMET2:DEF 'USB Power Meter 2',`  
                           `'NRP-Z55', 'usb', '100046'`  
 Configure two R&S NRP power meters as external power meter no. 1 and 2, assigning names and serial numbers.  
                           `SYST:COMM:RDEV:PMET:CAT?`  
 Query the power meter numbers. The response is '1, 2'.  
                           `SYST:COMM:RDEV:PMET:COUN?`  
 Query the number of configured power meters. The response is 2.

**Usage:**                Query only

**Manual operation:**   See ["Configured Devices"](#) on page 544

#### **SYSTem:COMMunicate:RDEvice:PMETer:CONFigure:AUTO[:STATE] <Boolean>**

Enables or disables auto-configuration of R&S NRPxxS/SN power sensors. If the function is enabled, the analyzer automatically configures all power sensors detected at any of the USB ports as Pmtr 1, Pmtr 2, ...

**Parameters:**

<Boolean>                ON | OFF – enable or disable auto-configuration.

**Example:**                See `SYSTem:COMMunicate:RDEvice:PMETer<Pmtr>:DEFine`

**Manual operation:**    See ["Auto Config"](#) on page 546

#### **SYSTem:COMMunicate:RDEvice:PMETer:COUNT?**

Queries the number of configured external power meters. The result is an integer number of power meters.

**Example:**                See `SYSTem:COMMunicate:RDEvice:PMETer:CATalog?`

**Usage:**                 Query only

**Manual operation:**    See ["Configured Devices"](#) on page 544

#### **SYSTem:COMMunicate:RDEvice:PMETer:DELeTe**

Clears the configuration table for external power meters.

**Example:**                See `SYSTem:COMMunicate:RDEvice:PMETer<Pmtr>:DEFine`

**Usage:**                 Event

**Manual operation:**    See ["Configured Devices"](#) on page 544



**SYSTem:COMMunicate:RDEvice:PMETer<Pmtr>:AZERo**

Starts auto zeroing of the external power meter.

**Suffix:**

<Pmtr>                      Number of the configured power meter. Power meters must be numbered in ascending order, starting with 1. If a number is reused, the previous power meter configuration is overwritten. Power meters can be assigned several times so that the number of configured power meters is practically unlimited.

**Usage:**                      Event

**Manual operation:**    See "Auto Zero" on page 247

**SYSTem:COMMunicate:RDEvice:PMETer<Pmtr>:DEFine <PmtrName>, <Driver>, <Interface>, <Address>[, <SensorId>]**

Configures an external power meter and adds it to the list of available power meters.

**Suffix:**

<Pmtr>                      Number of the configured power meter. Power meters must be numbered in ascending order, starting with 1. If a number is reused, the previous power meter configuration is overwritten. Power meters can be assigned several times so that the number of configured power meters is practically unlimited.

**Parameters:**

<PmtrName>                Name of the external power meter (string parameter). An empty string means that no particular name is assigned to the power meter.

<Driver>                    Power meter type (string parameter). The power meter type is identical with the name of the power meter driver file (\* .pwm) stored in the `resources\extdev` subdirectory of the analyzer's program directory. Type the driver file name as shown in the "Add External Powermeter" dialog, i.e. without the file extension ".pwm" (example: use 'NRVD', if the corresponding driver file name is `NRVD.pwm`).

**Alternative:** The '<Driver>' string can also contain the power meter driver file name with its complete path, e.g. '`C:\Program Files\Rohde-Schwarz\Vector Network Analyzer\ZNB\resources\extdev\nrvd.pwm`'.

<Interface>                Interface type (string parameter): 'GPIB0', 'VXI-11', 'socket', 'other', 'USB' (for the supported USB devices) ...

<Address>                    Interface address (string parameter), depending on the interface type. See [Table 6-5](#)

<SensorId> This optional string parameter is used for power meters that can control several power sensors, such as the R&S NRP2. By specifying the suitable <SensorId> you can address the related power sensor.  
The R&S NRP2, for example, has four power sensor connectors, Sensor A to Sensor D. By specifying 'A', 'B', 'C' or 'D', you can take control over the power sensor that is attached to this connector.

**Example:**

```
SYST:COMM:RDEV:PMET:CONF:AUTO OFF
```

Disables "Auto Config NRP-Zxx" (if it was enabled previously).

```
SYST:COMM:RDEV:PMET1:DEF 'USB Power Meter',
'NRP-Z55', 'usb', '100045'
```

Configure an R&S NRP power meter as external power meter no. 1, assigning the name "USB Power Meter" and a serial number 100045.

```
SYST:COMM:RDEV:PMET:DEL
```

Clear the power meter configuration table.

```
SYST:COMM:RDEV:PMET:DEF?
```

Query the power meter configuration. The analyzer returns an error message because the power meter no. 1 is no longer configured.

**Manual operation:** See "[Configured Devices](#)" on page 544

**SYSTem:COMMunicate:RDEvice:PMETer<Pmtr>:SPCorrection[:STATe]**  
<Boolean>

Gets/sets the state of the built-in S-parameter correction that is available on certain R&S@NRP-Z power sensors.

Note that this state is persistently stored on the power sensor (and NOT on the R&S ZND).

See Application Note 1GP70 "Using S-Parameters with R&S@NRP-Z Power Sensors" for background information. This Application Note is available on the Rohde & Schwarz internet at <http://www.rohde-schwarz.com/appnotes/1GP70>.

**Suffix:**

<Pmtr> Number of the configured power meter.

**Parameters:**

<Boolean> ON | OFF

**Manual operation:** See "[Deembed Two-Port \(All Channels\)](#)" on page 547

**SYSTem:COMMunicate:RDEvice:SMATrix<Matr>:CATalog?**

Queries the numbers of the switch matrices currently part of the RF configuration (see [INSTrument:SMATrix](#) on page 839). The response is a string containing a comma-separated list of switch matrix numbers.

|                 |        |                                                                                                                                                                                                                                                                                                                           |
|-----------------|--------|---------------------------------------------------------------------------------------------------------------------------------------------------------------------------------------------------------------------------------------------------------------------------------------------------------------------------|
| <b>Suffix:</b>  | <Matr> | This suffix is ignored and can be omitted.                                                                                                                                                                                                                                                                                |
| <b>Example:</b> |        | <p>Suppose switch matrices 1 and 2 are currently connected to the R&amp;S ZND.</p> <pre>SYST:COMM:RDEV:SMAT1:CAT?</pre> <p>Query the numbers of the connected switch matrices. The response is '1, 2'.</p> <pre>SYST:COMM:RDEV:SMAT1:COUN?</pre> <p>Query the number of connected switch matrices. The response is 2.</p> |
| <b>Usage:</b>   |        | Query only                                                                                                                                                                                                                                                                                                                |

### SYSTem:COMMunicate:RDEvice:SMATrix:CONFigure:ABORT

Aborts a manual RF connection configuration.

**Note:** a manual RF connection configuration must be performed within a transaction, enclosed by the commands `SYSTem:COMMunicate:RDEvice:SMATrix:CONFigure:START` and `SYSTem:COMMunicate:RDEvice:SMATrix:CONFigure:END`. The modified configuration will not be applied until the end of this transaction.

The new configuration is discarded, i.e. the previous configuration remains active ("rollback"). The transaction will be terminated.

**Usage:** Event

### SYSTem:COMMunicate:RDEvice:SMATrix:CONFigure:END

Ends a manual RF connection configuration: if the configuration is valid, it will be activated ("commit"). Otherwise an error is returned and the new configuration is discarded, i.e. the previous configuration remains active ("rollback").

In any case the transaction will be terminated.

**Note:** a manual RF connection configuration must be performed within a transaction, enclosed by the commands `SYSTem:COMMunicate:RDEvice:SMATrix:CONFigure:START` and `SYSTem:COMMunicate:RDEvice:SMATrix:CONFigure:END`. The modified configuration will not be applied until the end of this transaction.

The configuration is valid if

- every VNA port is either connected to a matrix port or directly assigned to a DUT test port
- every matrix that is part of the configuration is connected to the VNA by at least one RF connection
- every VNA port that is not connected to a matrix is assigned to a test port
- the test ports are numbered consecutively, starting with 1

**Example:** See `SYSTem:COMMunicate:RDEvice:SMATrix:CONFigure:START`

**Usage:** Event

---

### SYSTem:COMMunicate:RDEvice:SMATrix:CONFigure:START

Starts a manual RF connection configuration.

**Note:** a manual RF connection configuration must be performed within a transaction, enclosed by the commands `SYSTem:COMMunicate:RDEvice:SMATrix:CONFigure:START` and `SYSTem:COMMunicate:RDEvice:SMATrix:CONFigure:END`. The modified configuration will not be applied until the end of this transaction.

An RF connection configuration comprises the RF connections between the VNA, a set of switch matrices and the DUT test ports.

At transaction start the R&S ZND creates an in-memory copy of the active configuration and strips off all RF connections from this copy. Subsequent RF connection actions such as `SYSTem:COMMunicate:RDEvice:SMATrix<Matr>:CONFigure:MVNA` and `SYSTem:COMMunicate:RDEvice:SMATrix<Matr>:CONFigure:MTESt` operate on the copy.

However, the copy contains the very same switch matrices as the original, so the adequate set of matrices has to be selected beforehand (using manual control or the remote command `INSTRument:SMATrix`).

If a previous transaction is active, it will be silently rolled back.

**Example:**

```
:INSTRument:SMATrix OFF
```

Remove all switch matrices from the RF configuration.

```
:SYSTem:COMMunicate:RDEvice:SMATrix:DELeTe
```

Unconfigure all switch matrices, i.e. remove them from the list of configured devices.

```
:SYSTem:COMMunicate:RDEvice:SMATrix1:DEFine ' ',
'ZN-Z84-02', 'LAN', '192.168.0.42'
```

Register a single switch matrix of type ZV-Z82-30 (with two 2x5 submatrices).

```
:INSTRument:SMATrix ON
```

Add the matrix to the RF configuration, performing a default assignment of VNA ports and test ports.

```
:SYSTem:COMMunicate:RDEvice:SMATrix:CONFigure:
START
```

Start a manual RF connection configuration.

```
:SYSTem:COMMunicate:RDEvice:SMATrix1:CONFigure:
MVNA 1,2,2,1
```

Define non-default matrix-VNA port connections: matrix port 1 to VNA port 2, matrix port 2 to VNA port 1 (default is 1,1,2,2).

```
:SYSTem:COMMunicate:RDEvice:SMATrix1:CONFigure:
MTESt 1,2,2,3,3,4,4,5,5,6,6,1
```

Configure 6 matrix test ports: matrix test port *i* is test port *i*+1 (modulus 6).

```
:SYSTem:COMMunicate:RDEvice:SMATrix:CONFigure:
END
```

Apply the manual RF connection configuration.

**Usage:** Event

---

**SYSTem:COMMunicate:RDEvice:SMATrix:CONFigure:TVNA** <TestPort1>[, <VNAPort1>]...

Sets/gets the test port connections of the VNA in a switch matrix RF connection setup, i.e. the direct assignments of test ports to physical VNA ports.

**Note:** a manual RF connection configuration must be performed within a transaction, enclosed by the commands `SYSTem:COMMunicate:RDEvice:SMATrix:CONFigure:START` and `SYSTem:COMMunicate:RDEvice:SMATrix:CONFigure:END`. The modified configuration will not be applied until the end of this transaction.

**Setting parameters:**

<TestPort1>            Number of the test port.  
Test ports must be numbered subsequently starting at 1.

<VNAPort1>            Number of the VNA port

**Example:**            `SYSTem:COMMunicate:RDEvice:SMATrix:CONFigure:TVNA 7,2`  
Test Ports 7 is assigned to VNA port 2.

**Manual operation:** See "[Edit Test Port Connection](#)" on page 555

---

**SYSTem:COMMunicate:RDEvice:SMATrix:COUNT?**

Gets the number of configured switch matrices (see `SYSTem:COMMunicate:RDEvice:SMATrix<Matr>:DEFine` on page 1034)

**Usage:**                Query only

**Manual operation:** See "[Configured Devices](#)" on page 549

---

**SYSTem:COMMunicate:RDEvice:SMATrix:DELeTe**

Unregisters all switch matrices, i.e. removes them from the list of configured devices.

**Example:**            See `SYSTem:COMMunicate:RDEvice:SMATrix:CONFigure:START`

**Usage:**                Event

**Manual operation:** See "[Delete All](#)" on page 551

---

**SYSTem:COMMunicate:RDEvice:SMATrix:SCAN?**

Scans for external switch matrices connected via USB or Direct Control.

Returns a comma separated list

<Driver\_1>, <Interface\_1>, <Address\_1>, ..., <Driver\_N>, <Interface\_N>, <Address\_N>, one triple  
<Driver\_n>, <Interface\_n>, <Address\_n> for each detected switch matrix  
<Matr>=1, ..., N.

Use `SYSTem:COMMunicate:RDEvice:SMATrix<Matr>:DEFine` to configure them.

**Usage:** Query only

**Manual operation:** See "Scan Instruments" on page 550

**SYSTem:COMMunicate:RDEvice:SMATrix<Matr>:DEFine** <Unused>, <Driver>, <Interface>, <Address>

This command allows

- to configure (i.e. register) a new switching matrix
- to modify the (management) connection settings of an already configured switching matrix
- to get the (management) connection settings of a configured switching matrix

**Suffix:**

<Matr> Index of the switch matrix.  
Switch matrices are numbered in ascending order, starting with 1. If a number is re-used, the current configuration is overwritten.

**Parameters:**

<Unused> Currently this parameter is ignored and always returns an empty string ' '.

<Driver> Matrix driver name indicating the matrix type (string parameter).  
**Standard drivers:** The supported drivers are displayed in the "Driver" dropdown-list of the "Add External Switchmatrix" dialog. Each list entry corresponds to a matrix driver file (\*.matrix) located in the Resources\ExtDev subdirectory of the analyzer's program directory. Specify the <Driver> as the driver's file name without the \*.matrix extension, e.g. as "ZV-Z81-05".  
**Non-standard driver location:** You may also specify the full absolute path to an appropriate driver file, e.g. "C:\Program Files\Rohde-Schwarz\Vector Network Analyzer\ZNB\Resources\ExtDev\ZV-Z81-05.matrix".

<Interface> Interface type (string parameter)

**'USB'**  
USB interface

**'LAN'**  
LAN interface

<Address> Interface-specific address (string parameter).

**Example:**                   :SYST:COMM:RDEV:SMATrix1:DEF ' ', 'ZN-Z84-42',  
                                  'USB', '101142'  
Register switch matrix no.1: type R&S ZN-Z84 (2x24) with serial  
number 101142 at USB interface.  
                                  :SYST:COMM:RDEV:SMATrix2:DEF ' ', 'ZV-Z81-05',  
                                  'LAN', '10.10.10.10'  
Register switch matrix no.2: type R&S ZV-Z81 (model .05) at IP  
address 10.10.10.10.

**Manual operation:** See ["Add Device"](#) on page 550

**SYSTem:COMMunicate:RDEvice:SMATrix<Matr>:CONFigure:MLVNa** {<Matrix VNA  
Port Label>, <VNA Port Number>}

Sets/gets the RF connections between switch matrix and VNA. Similar to [SYSTem:COMMunicate:RDEvice:SMATrix<Matr>:CONFigure:MVNA](#), but uses the front panel labels of the matrix VNA ports instead.

By default, these labels are only available for some matrix types.

**Note:** a manual RF connection configuration must be performed within a transaction, enclosed by the commands [SYSTem:COMMunicate:RDEvice:SMATrix:CONFigure:START](#) and [SYSTem:COMMunicate:RDEvice:SMATrix:CONFigure:END](#). The modified configuration will not be applied until the end of this transaction.

**Suffix:**

<Matr>                   Index of the switch matrix (see [SYSTem:COMMunicate:RDEvice:SMATrix<Matr>:DEFine](#) on page 1034)

**Setting parameters:**

<Matrix VNA Port Label>   These labels are specified in the corresponding matrix driver file (see [SYSTem:COMMunicate:RDEvice:SMATrix<Matr>:DEFine](#) on page 1034).

<VNA Port Number>   Range:        1 ... # of RF ports of the VNA

**Example:**                   A switch matrix ZV-Z84-02 is used.  
                                  SYSTem:COMMunicate:RDEvice:SMATrix1:CONFigure:  
                                  MLVNA '1A',1,'2B',2  
                                  VNA ports 1 and 2 are connected to matrix VNA ports '1A' and  
                                  '2B', respectively

**Manual operation:** See ["Edit Matrix VNA Port Connections"](#) on page 555

**SYSTem:COMMunicate:RDEvice:SMATrix<Matr>:CONFigure:MLTest** {<Matrix Test  
Port Label>, <TPNumber>}

Sets/gets the matrix test port connections. Similar to [SYSTem:COMMunicate:RDEvice:SMATrix<Matr>:CONFigure:MTEST](#), but uses the front panel labels of the matrix test ports instead.

By default, these labels are only available for some matrix types.

**Note:** a manual RF connection configuration must be performed within a transaction, enclosed by the commands `SYSTem:COMMunicate:RDEvice:SMATrix:CONFigure:START` and `SYSTem:COMMunicate:RDEvice:SMATrix:CONFigure:END`. The modified configuration will not be applied until the end of this transaction.

**Suffix:**

<Matr> Index of the switch matrix (see `SYSTem:COMMunicate:RDEvice:SMATrix<Matr>:DEFine` on page 1034)

**Setting parameters:**

<Matrix Test Port Label> If available, these labels are specified in the corresponding matrix driver file (see `SYSTem:COMMunicate:RDEvice:SMATrix<Matr>:DEFine` on page 1034).

<Test Port Number> Test ports must be numbered subsequently, starting at 1.

**Example:**

A switch matrix ZV-Z82-16 is used.

```
SYSTem:COMMunicate:RDEvice:SMATrix1:CONFigure:
MLTEST 'A1',1,'B1',2
```

The first test ports of submatrices A and B are assigned to test ports 1 and 2, respectively.

**Manual operation:** See "[Edit Test Port Connection](#)" on page 555

### `SYSTem:COMMunicate:RDEvice:SMATrix<Matr>:CONFigure:MTEST` {<MatrixTestPort>, <TestPort>}

Sets/gets the matrix test port connections as a comma-separated list of port numbers

**Note:** a manual RF connection configuration must be performed within a transaction, enclosed by the commands `SYSTem:COMMunicate:RDEvice:SMATrix:CONFigure:START` and `SYSTem:COMMunicate:RDEvice:SMATrix:CONFigure:END`. The modified configuration will not be applied until the end of this transaction.

**Suffix:**

<Matr> Index of the switch matrix (see `SYSTem:COMMunicate:RDEvice:SMATrix<Matr>:DEFine` on page 1034)

**Setting parameters:**

{<MatrixTestPort> Number of the switch matrix test port

<TestPort>} Number of the test port.  
Test ports must be numbered subsequently starting at 1.

**Example:**

See `SYSTem:COMMunicate:RDEvice:SMATrix:CONFigure:START`

**Manual operation:** See "[Edit Test Port Connection](#)" on page 555

### `SYSTem:COMMunicate:RDEvice:SMATrix<Matr>:CONFigure:MVNA` {<MatrixVNAPort>, <VNAPort>}

Sets/gets the RF connections between switch matrix and VNA as a comma-separated list of port numbers.



**Note:** a manual RF connection configuration must be performed within a transaction, enclosed by the commands `SYSTem:COMMunicate:RDEvice:SMATrix:CONFigure:START` and `SYSTem:COMMunicate:RDEvice:SMATrix:CONFigure:END`. The modified configuration will not be applied until the end of this transaction.

**Suffix:**

<Matr> Configuration index of the switch matrix (see `SYSTem:COMMunicate:RDEvice:SMATrix<Matr>:DEFine` on page 1034)

**Setting parameters:**

{<MatrixVNAPort> Number of the switch matrix VNA port  
Range: 1 ... # of VNA ports of the switch matrix

<VNAPort>} Number of the VNA port  
Range: 1 ... # of RF ports of the VNA

**Example:** See `SYSTem:COMMunicate:RDEvice:SMATrix:CONFigure:START`

**Manual operation:** See "Edit Matrix VNA Port Connections" on page 555

**SYSTem:COMMunicate:RDEvice:SMATrix<Matr>:RELays:SWITCh:COUNT?**

For mechanical matrices, this command allows to query the list of switch counts for all relays (if supported by the matrix).

**Suffix:**

<Matr> Index of the switch matrix (see `SYSTem:COMMunicate:RDEvice:SMATrix<Matr>:DEFine` on page 1034)

**Usage:** Query only

**Manual operation:** See "Configured External Switch Matrices" on page 535

**SYSTem:COMMunicate:RDEvice:SMATrix<Matr>:SERial?**

Returns the serial number of the related switch matrix.

**Suffix:**

<Matr> Index of the switch matrix (see `SYSTem:COMMunicate:RDEvice:SMATrix<Matr>:DEFine` on page 1034)  
If the switch matrix is not part of the RF configuration, the query returns an "Invalid suffix" error.

**Usage:** Query only

**Manual operation:** See "Configured Devices" on page 549

### 8.3.17.2 SYSTem:DATA:MEMory...

These commands allow you to configure memory-mapped trace data transfer. See [Chapter 5.4.3, "Memory-Mapped Trace Data Transfer"](#), on page 138.

---

**SYSTem:DATA:MEMory:ADD** <TraceName>, <DataFormat>, <NumberOfPoints>

Adds trace <TraceName> to a previously initialized shared memory buffer.

Traces can only be added after the `SYSTem:DATA:MEMory:INITalize` and before the corresponding `SYSTem:DATA:MEMory:COMMit`.

For background information, see [Chapter 5.4.3, "Memory-Mapped Trace Data Transfer"](#), on page 138.

**Setting parameters:**

<TraceName> Trace name. Identifies the trace within the active recall set.

<DataFormat> SDATa | FDATa  
The data format of the stored trace values.

**SDATa**

Unformatted (complex) trace data.

**FDATa**

Formatted (real-valued) trace data.

<NumberOfPoints> Number of trace values to be stored.

**Usage:** Setting only

---

**SYSTem:DATA:MEMory:CATalog?**

Queries the names of the shared memory buffers initialized using `SYSTem:DATA:MEMory:INITalize`.

Before the `SYSTem:DATA:MEMory:COMMit`, an initialized shared memory buffer has the temporary name `NewMemory`.

For background information, see [Chapter 5.4.3, "Memory-Mapped Trace Data Transfer"](#), on page 138.

**Usage:** Query only

---

**SYSTem:DATA:MEMory:COMMit** <ShMemName>

Completes the setup of a named shared memory buffer that was initialized using `SYSTem:DATA:MEMory:INITalize` and configured using one or more `SYSTem:DATA:MEMory:ADD`. The buffer is then available in Windows.

Before the next `COMMit`, the size of the created buffer can be queried using `SYSTem:DATA:MEMory:SIZE?`.

To delete the buffer and free its memory, use `SYSTem:DATA:MEMory:DElete` <ShMemName>, or `SYSTem:DATA:MEMory:RESet`.

For background information, see [Chapter 5.4.3, "Memory-Mapped Trace Data Transfer"](#), on page 138.

**Setting parameters:**

<ShMemName> Gives the shared memory buffer a name, which is required by processes that want to access it. The name must be unique within the running Windows instance. The names of the shared memory buffers initialized using `SYSTEM:DATA:MEMORY:INITIALIZE` can be queried using `SYSTEM:DATA:MEMORY:CATALOG?`.

**Usage:** Setting only

**SYSTEM:DATA:MEMORY:DELETE** <ShMemName>

Deletes a shared memory buffer <ShMemName> initialized using `SYSTEM:DATA:MEMORY:INITIALIZE`.

Before the `SYSTEM:DATA:MEMORY:COMMIT`, an initialized shared memory buffer has the temporary name `NewMemory`. Do not delete it.

**Setting parameters:**

<ShMemName> Unique name of the shared memory buffer.

**Usage:** Setting only

**SYSTEM:DATA:MEMORY:INITIALIZE**

Initializes a new shared memory buffer.

- Use `SYSTEM:DATA:MEMORY:ADD` to add traces to it.
- Finally, use `SYSTEM:DATA:MEMORY:COMMIT` to complete the setup and create the named shared memory buffer in Windows.

For background information, see [Chapter 5.4.3, "Memory-Mapped Trace Data Transfer"](#), on page 138.

**Usage:** Event

**SYSTEM:DATA:MEMORY:OFFSET?**

Queries the offset in bytes of the last added trace data block, relative to the start of the shared memory buffer (see `SYSTEM:DATA:MEMORY:ADD`).

The offset is required by processes that want to read the trace data from the buffer.

For background information, see [Chapter 5.4.3, "Memory-Mapped Trace Data Transfer"](#), on page 138.

**Usage:** Query only

**SYSTem:DATA:MEMory:RESet**

Deletes all shared memory buffers initialized using `SYSTem:DATA:MEMory:INITalize`.

For background information, see [Chapter 5.4.3, "Memory-Mapped Trace Data Transfer"](#), on page 138.

**Usage:** Event

**SYSTem:DATA:MEMory:SIZE?**

Queries the size of the shared memory buffer that was last created using `SYSTem:DATA:MEMory:COMMit`.

For background information, see [Chapter 5.4.3, "Memory-Mapped Trace Data Transfer"](#), on page 138.

**Usage:** Query only

**8.3.17.3 SYSTem... (Contd.)**

The following `SYSTem...` commands provide general instrument configurations.

|                                                              |      |
|--------------------------------------------------------------|------|
| <code>SYSTem:AGC:GLOBal:METHod</code> .....                  | 1041 |
| <code>SYSTem:CORRection:WIZard[:IMMediate]</code> .....      | 1041 |
| <code>SYSTem:DATE</code> .....                               | 1042 |
| <code>SYSTem:DFPPrint?</code> .....                          | 1042 |
| <code>SYSTem:DISPlay:BAR:HKEY[:STATe]</code> .....           | 1042 |
| <code>SYSTem:DISPlay:BAR:MENU[:STATe]</code> .....           | 1042 |
| <code>SYSTem:DISPlay:BAR:STATus[:STATe]</code> .....         | 1042 |
| <code>SYSTem:DISPlay:BAR:STOOls[:STATe]</code> .....         | 1042 |
| <code>SYSTem:DISPlay:BAR:TITLe[:STATe]</code> .....          | 1042 |
| <code>SYSTem:DISPlay:BAR:TOOLs[:STATe]</code> .....          | 1042 |
| <code>SYSTem:DISPlay:COLor</code> .....                      | 1043 |
| <code>SYSTem:DISPlay:CONDuctances</code> .....               | 1043 |
| <code>SYSTem:DISPlay:DIALogs:SETup:MCAL[:STATe]</code> ..... | 1043 |
| <code>SYSTem:DISPlay:TRACes:CCOunt</code> .....              | 1043 |
| <code>SYSTem:DISPlay:UPDate</code> .....                     | 1044 |
| <code>SYSTem:ERRor:COUNT?</code> .....                       | 1044 |
| <code>SYSTem:ERRor[:NEXT]?</code> .....                      | 1044 |
| <code>SYSTem:ERRor:ALL?</code> .....                         | 1044 |
| <code>SYSTem:ERRor:DISPlay[:REMote]</code> .....             | 1045 |
| <code>SYSTem:ERRor:DISPlay:INFO</code> .....                 | 1045 |
| <code>SYSTem:ERRor:DISPlay:WARNings</code> .....             | 1045 |
| <code>SYSTem:ERRor:DISPlay:ERRor</code> .....                | 1045 |
| <code>SYSTem:ERRor:DISPlay:STATe</code> .....                | 1046 |
| <code>SYSTem:FIRMware:UPDate</code> .....                    | 1046 |
| <code>SYSTem:FPReset</code> .....                            | 1046 |
| <code>SYSTem:FREQuency?</code> .....                         | 1047 |
| <code>SYSTem:HELP:HEADers?</code> .....                      | 1047 |

|                                  |      |
|----------------------------------|------|
| SYSTem:HELP:SYNTax?              | 1047 |
| SYSTem:HELP:SYNTax:ALL?          | 1048 |
| SYSTem:IDENtify[:STRing]         | 1048 |
| SYSTem:IDENtify:FACTory          | 1048 |
| SYSTem:KLOCK                     | 1048 |
| SYSTem:LANGuage                  | 1049 |
| SYSTem:LOGGing:REMote[:STATe]    | 1049 |
| SYSTem:OPTions:FACTory           | 1049 |
| SYSTem:OPTions[:STRing]          | 1050 |
| SYSTem:PASSword[:CENable]        | 1050 |
| SYSTem:PRESet[:DUMMy]            | 1050 |
| SYSTem:PRESet:REMote[:STATe]     | 1050 |
| SYSTem:PRESet:SCOPE              | 1051 |
| SYSTem:PRESet:START              | 1051 |
| SYSTem:PRESet:USER[:STATe]       | 1051 |
| SYSTem:PRESet:USER:CAL           | 1052 |
| SYSTem:PRESet:USER:NAME          | 1052 |
| SYSTem:SETTings:UPDate           | 1053 |
| SYSTem:SMATrix:OPTimization      | 1053 |
| SYSTem:SHUTdown                  | 1054 |
| SYSTem:SOUNd:ALARm[:STATe]       | 1054 |
| SYSTem:SOUNd:STATus[:STATe]      | 1054 |
| SYSTem:TIME                      | 1054 |
| SYSTem:TRESet[:STATe]            | 1055 |
| SYSTem:TSLock                    | 1055 |
| SYSTem:TTLout<Pt>:STATus[:STATe] | 1055 |
| SYSTem:USER:DISPlay:TITLe        | 1056 |
| SYSTem:USER:KEY                  | 1056 |
| SYSTem:VERSion?                  | 1057 |

---

#### **SYSTem:AGC:GLOBal:METHOD** <Global AGC Method>

Allows you to select between two AGC algorithms.

##### **Setting parameters:**

|             |                |
|-------------|----------------|
| <Global AGC | POINT   MEMory |
| Method>     | <b>POINT</b>   |
|             | Point AGC      |
|             | <b>MEMory</b>  |
|             | Memory AGC     |

---

#### **SYSTem:CORRection:WIZard[:IMMEDIATE]** <Dialogs>

Keysight-compatible command to open the [Start Cal Tab](#) or the [Calibration Kits Dialog](#).

**Tip:** When working with the [Chapter 7.1.2, "GPIB Explorer"](#), on page 560, switch to raw mode ("Options">"Raw mode" in the IECWIN32 GUI) before executing this command.

**Setting parameters:**

<Dialogs>           MAIN | CKIT  
                           MAIN: open the "Calibration > Start Cal" softtool tab  
                           CKIT: open the "Calibration Kits" dialog

**Usage:**               Setting only

**SYSTem:DATE** <Year>, <Month>, <Day>

The command queries or defines the instrument's current date setting.

The setting command requires administrator rights; refer to [Chapter 11.1.1, "Windows Operating System"](#), on page 1149.

**Parameters:**

<Year>                Year, four-digit number  
 <Month>              Month, two-digit number, 01 (for January) to 12 (for December)  
 <Day>                 Day, two-digit number, 01 to the number of days in the month

**Example:**

SYST:DATE?  
 Response: 2012, 05, 01 - it is the 1st of May, 2012.

**SYSTem:DFPPrint?**

Queries the device footprint. The device footprint contains detailed information about the instrument and is mostly used for service purposes.

**Usage:**               Query only

**Manual operation:** See ["Save..."](#) on page 533

**SYSTem:DISPlay:BAR:HKEY[:STATe]** <Boolean>  
**SYSTem:DISPlay:BAR:MENU[:STATe]** <Boolean>  
**SYSTem:DISPlay:BAR:STATus[:STATe]** <Boolean>  
**SYSTem:DISPlay:BAR:STOols[:STATe]** <Boolean>  
**SYSTem:DISPlay:BAR:TITLe[:STATe]** <Boolean>  
**SYSTem:DISPlay:BAR:TOOLs[:STATe]** <Boolean>

Displays or hides the hardkey panel (HKEY), the menu bar below the diagram area (MENU), the status bar below the diagram area (STATus), the softtool panel (STOols), the title bar of the main VNA application window (TITLe), and the toolbar above the diagram area (TOOLs).

**Parameters:**

<Boolean>            ON | OFF  
                           Display or hide the information elements.

**Example:**            `SYSTem:DISPlay:BAR:TOOLs ON; STOOls ON; STATus ON`  
                           Display the toolbar, softtool panel, and status bar.  
                           `SYSTem:DISPlay:BAR:TITle OFF; HKEY OFF; MENU OFF`  
                           Hide the title bar, hardkey bar, and menu bar.

**Manual operation:** See ["Tool Bar"](#) on page 516

### **SYSTem:DISPlay:COLor <ColorScheme>**

Selects the color scheme for all diagram areas in the active recall set.

**Parameters:**

<ColorScheme>        DBACKground | LBACKground | BWLStyles | BWSolid  
                           DBACKground - dark background  
                           LBACKground - light background  
                           BWLStyles - black and white line styles  
                           BWSolid - black and white solid

**Example:**            `SYST:DISP:COL LBAC`  
                           Independent of the selected color scheme, hardcopies are always generated with the light background scheme.

**Manual operation:** See ["Color Scheme"](#) on page 509

### **SYSTem:DISPlay:CONDuctances <Boolean>**

Changes the presentation of "capacitance C<i>" in parallel with resistance R<i>" circuit blocks in lumped de/embedding networks.

**Parameters:**

<Boolean>            ON - display conductances  
                           OFF - display capacitaces

**Manual operation:** See ["Conductance in Embedding Networks"](#) on page 523

### **SYSTem:DISPlay:DIALogs:SETup:MCAL[:STATe] <Boolean>**

Enables/disables multiple calibrations in the calibration wizard.

**Parameters:**

<Boolean>

### **SYSTem:DISPlay:TRACes:CCOunt <ColorCount>**

Defines the maximum number of trace colors (trace properties for the user defined color scheme defined using `DISPlay:CMAP<DispEl>:RGB`.

**Parameters:**

<ColorCount>        Range:        1 to 100

**Manual operation:** See ["Number of Trace Colors"](#) on page 524

---

### SYSTem:DISPlay:UPDate <Activate>

Switches the display on or off while the analyzer is in the remote state. The command has no effect while the analyzer is in the local operating state.

**Tip:** Switching off the display speeds up the measurement. This command may have an impact on the update of trace and channel settings; see [SYSTem:SETTings:UPDate](#).

#### Parameters:

<Activate>                    ON | OFF - switch the display on or off. If the display is switched on, the analyzer shows the diagrams and traces like in manual control.  
                                   ONCE - switch the display on and show the current trace. This parameter can be used for occasional checks of the measurement results or settings. The measurement is continued, however, the measurement results are not updated. Compared to the ON setting, ONCE does not slow down the measurement speed.

**Example:**                    SYST:DISP:UPD ON  
                                   Switch the display on to view the traces and diagrams.

---

### SYSTem:ERRor:COUNT?

Gets the current number of entries in the SCPI error queue.

**Usage:**                      Query only

---

### SYSTem:ERRor[:NEXT]?

Queries and at the same time deletes the oldest entry in the error queue. Operation is identical to that of [STATus:QUEue\[:NEXT\]?](#)

The entry consists of an error number and a short description of the error. Positive error numbers are instrument-dependent. Negative error numbers are reserved by the SCPI standard; see section [Error Messages and Troubleshooting](#).

**Example:**                    SYST:ERR?  
                                   Query the oldest entry in the error queue. 0, "No error" is returned if the error queue is empty.

**Usage:**                      Query only

---

### SYSTem:ERRor:ALL?

Queries and at the same time deletes all entries in the error queue.



The entries consist of an error number and a short description of the error. Positive error numbers are instrument-dependent. Negative error numbers are reserved by the SCPI standard; see section [Error Messages and Troubleshooting](#).

**Example:** `SYST:ERR:ALL?`  
Query all entries in the error queue. 0, "No error" is returned if the error queue is empty.

**Usage:** Query only

### **SYSTem:ERRor:DISPlay[:REMote]** <Boolean>

Disables or enables the display of information popups for remote control errors. These popups appear at the bottom of the remote screen and the manual screen.

#### **Note**

- Display of information popups can be globally disabled/enabled using `SYSTem:ERRor:DISPlay:STATe OFF/ON`
- For SCPI error -113, `Undefined header no tooltip` is displayed

#### **Parameters:**

<Boolean> ON | OFF - enable/disable display of information popups for remote control errors

\*RST: ON

**Example:** `SYST:ERR:DISP:STATe ON; REM ON`  
Switch the display of information popups for remote command errors on.  
`FREQ:STAR -1`  
Generate a Remote Error: -222, "Data out of range; ..." tooltip.

**Manual operation:** See ["Show Remote Error Info Messages"](#) on page 525

### **SYSTem:ERRor:DISPlay:INFO** <Boolean>

### **SYSTem:ERRor:DISPlay:WARNings** <Boolean>

### **SYSTem:ERRor:DISPlay:ERRor** <Boolean>

Selectively disables or enables the display of information popups for the related event type (Information, Warning, System Error).

**Note** that the display of information popups can be globally disabled/enabled using `SYSTem:ERRor:DISPlay:STATe OFF/ON`.

#### **Parameters:**

<Boolean> ON | OFF - enable/disable display of information popups for the related event type

\*RST: ON

- Example:** `SYST:ERR:DISP:STATe ON; ERR ON; WARN:OFF; INFO OFF`  
 Display information popups for system errors, but not for warnings and information messages.
- Manual operation:** See ["Show Info Messages / Show Warning Messages / Show Error Messages"](#) on page 525

**SYSTem:ERRor:DISPlay:STATe** <Boolean>

Globally defines whether instrument events shall be indicated by information popups.

Display of popups can be limited to certain event types using commands `SYSTem:ERRor:DISPlay:INFO`, `SYSTem:ERRor:DISPlay:WARNings`, `SYSTem:ERRor:DISPlay:ERRor`, and `SYSTem:ERRor:DISPlay[:REMote]`.

**Parameters:**

<Boolean> ON | OFF - globally enable or disable the display of information popups  
 \*RST: ON

**Example:** See `SYSTem:ERRor:DISPlay:ERRor` and `SYSTem:ERRor:DISPlay[:REMote]`.

**Manual operation:** See ["Show Instrument Messages"](#) on page 525

**SYSTem:FIRMware:UPDate** <VNASetupFile>

Installs a firmware version stored in a VNA setup file (\*.exe) on the analyzer. The installation is automatic and does not require any further action.

**Setting parameters:**

<VNASetupFile> String variable for the name and directory of a VNA setup file.

**Example:** `SYST:FIRM:UPD 'C:\Users\Public\Setup\ZND_3.00.exe'`  
 Install firmware version V3.00 from the setup file stored in the public directory of the analyzer's internal hard disk.

**Usage:** Setting only

**SYSTem:FPReset**

Performs a factory preset of all instrument settings (i.e. all open recall sets) or of the active recall set, depending on the `SYSTem:PRESet:SCOPE` settings, and deletes channel 1 in the active recall set. As a result, the active recall set contains no channels, traces, and diagram areas.

**Example:**            `SYST:PRES:SCOP SING`  
 Define the scope of a preset: the active recall set is reset only.  
`SYST:FPR`  
 Reset the parameters of the current recall set and delete channel 1.

**Usage:**            Event

### **SYSTem:FREQuency? <MinMax>**

Queries the minimum and maximum frequency of the network analyzer. For an overview refer to the tables at the beginning of [Chapter 8.3.14.10](#), "[SENSe:]FRE-Quency...", on page 960.

**Tip:** In contrast to `[SENSe<Ch>:]FREQuency:START?` and the other sweep range commands, `SYSTem:FREQuency?` can be used in all sweep modes.

**Query parameters:**

<MinMax>            MINimum | MAXimum

**Return values:**

<Frequency>        MINimum | MAXimum  
 Return minimum or maximum frequency.

**Example:**            See `[SENSe<Ch>:]FREQuency:CENTer`

**Usage:**            Query only

**Manual operation:** See "Start Frequency / Stop Frequency / Center Frequency / Span Frequency" on page 346

### **SYSTem:HELP:HEADers? [<ParserName>]**

Returns a list of all SCPI commands supported by the related parser (or the default parser, if omitted).

**Query parameters:**

<ParserName>        Parser name

**Return values:**

<Commands>        SCPI command headers, one per line

**Usage:**            Query only

### **SYSTem:HELP:SYNTax? <Command>**

This command returns the full syntax of the specified command.

**Query parameters:**

<Command>

**Return values:**

<CommandDesc>    String containing the command you want to query.

**Example:** `SYST:HELP:SYNT? 'SYST:ERR?'`  
Returns the full syntax. In this case: 'SYSTem:ERRor[:NEXT]'

**Usage:** Query only

### SYSTem:HELP:SYNTax:ALL?

Queries the implemented SCPI commands and their parameters.

**Return values:**  
<Commands>

**Usage:** Query only

### SYSTem:IDENtify[:STRing] <InstId>

Defines an identity string for the network analyzer. The query is equivalent to `*IDN?`.

**Parameters:**  
<InstId> String parameter containing the instrument identity

**Example:** See [SYSTem:IDENtify:FACTory](#)

**Manual operation:** See "[Define \\*IDN + \\*OPT...](#)" on page 540

### SYSTem:IDENtify:FACTory

Resets the response to the `*IDN?` query to the factory default value. This command overwrites a user-defined identification string; see example.

**Example:** `SYSTem:IDENtify:STRing 'MyDevice'; *IDN?`  
Define an identity string. The response is MyDevice.  
`SYSTem:IDENtify:FACTory; *IDN?`  
Re-activate the factory setting. The response is  
Rohde-Schwarz,<instrument type>-<ports>,<stock  
no.><serial no.>,<firmware version>.

**Usage:** Event

**Manual operation:** See "[Define \\*IDN + \\*OPT...](#)" on page 540

### SYSTem:KLOCK <Boolean>

Locks or unlocks the local controls of the analyzer. This includes the front panel keys, the keyboard, or other local interfaces.

**Parameters:**  
<Boolean> ON | OFF - lock or unlock the local keys.  
`*RST: OFF`

**Example:** `SYST:KLOCK ON`  
Lock the local keys.

**SYSTem:LANGuage** <Language>

Specifies the remote language for the analyzer.

**Parameters:**

<Language> Command syntax for the analyzer, string variable:  
 'SCPI' – R&S ZND-specific command set: the analyzer supports all commands described in this documentation.  
 'ZVR' | 'ZVABT' – compatibility with network analyzers of the R&S ZVR and R&S ZVA/B/T families.  
 'PNA' | 'HP8510' | 'HP8720' | 'HP8753' | 'HP8714' | 'HP8530' | 'ENA' – compatibility with network analyzers from other manufacturers.  
 \*RST: n/a - a reset does not affect the language setting. The factory setting is SCPI.

**Example:**

```
SYST:LANG 'PNA'
```

Select a PNA-compatible command set.

**Manual operation:** See "[Remote Language](#)" on page 540

**SYSTem:LOGGing:REMote[:STATe]** <Boolean>

Enables logging of all remote control commands transferred to the analyzer.

**Parameters:**

<Boolean> ON – command sequence stored to file  
 C:\Users\Public\Documents\Rohde-Schwarz\Vna\RemoteLog\VNARemote.log.  
 OFF – command sequence not logged.

**Example:**

```
SYST:LOGG:REM ON
```

Enable remote logging. The log file 'C:\Users\Public\Documents\Rohde-Schwarz\Vna\RemoteLog\VNARemote.log' is fixed and does not have to be specified.

**SYSTem:OPTions:FACTory**

Resets the response to the \*OPT? query to the factory default value. This command overwrites a user-defined option string; see example.

**Example:**

```
SYSTem:OPTions:STRing 'MyOptions'; *OPT?
```

Define an identity string. The response is MyOptions.

```
SYSTem:OPTions:FACTory; *OPT?
```

Re-activate the factory setting. The analyzer returns a comma-separated list of software and hardware options.

**Usage:**

Event

**Manual operation:** See "[Define \\*IDN + \\*OPT...](#)" on page 540

---

**SYSTem:OPTions[:STRing] <Options>**

Defines an option string for the network analyzer. The query is equivalent to \*OPT?.

**Parameters:**

<Options> String parameter containing the available options

**Example:** See [SYSTem:OPTions:FACTory](#)

**Manual operation:** See "[Define \\*IDN + \\*OPT...](#)" on page 540

---

**SYSTem:PASSword[:CENable] <Password>**

Sends a password to the analyzer enabling a class of service functions to function (Command ENable). Service functions are activated with the commands of the `DIAGnostic...` system and should be used by a R&S service representative only.

**Setting parameters:**

<Password> Case-sensitive string variable. Sending an invalid password generates error -221, (settings conflict).

**Example:** `SYST:PASS "XXXX"`  
Enter password.

**Usage:** Setting only

**Manual operation:** See "[Password](#)" on page 538

---

**SYSTem:PRESet[:DUMMy]**

Performs a preset, whose scope is defined using the [SYSTem:PRESet:SCOPE](#) command. The [SYSTem:PRESet:USER\[:STATe\]](#) command determines whether a factory preset or a user-defined preset is performed.

**Example:** `SYST:PRESet:SCOPE SING`  
Define the scope of a preset: the active recall set is reset only.  
`SYST:PRESet`  
Reset the parameters of the current recall set to their factory defaults.

**Manual operation:** See "[Preset Scope](#)" on page 520

---

**SYSTem:PRESet:REMOte[:STATe] <Boolean>**

Defines the behavior of the preset commands \*RST and [SYSTem:PRESet\[:DUMMy\]](#)

**Parameters:**

<Boolean> **OFF (0)**  
\*RST and [SYSTem:PRESet](#) perform a factory preset.

**ON (1)**

\*RST and [SYSTem:PRESet](#) restore the user preset file selected using [SYSTem:PRESet:USER:NAME](#), if this file is available and valid. Otherwise, they perform a factory preset.

**Manual operation:** See "Remote Preset Configuration" on page 520

---

### **SYSTem:PRESet:SCOPE** <Scope>

Specifies whether the preset actions affect all open recall sets, or only the active recall set.

Applies to the GUI and the `SYSTem:PRESet[:DUMMy]` command. The `*RST` command always resets all open recall sets.

**Parameters:**

<Scope>

ALL | SINGle

**ALL**

All open recall sets are deleted and a new recall set "Set1" is created according to the current preset mode.

See `SYSTem:PRESet:USER[:STATe]` on page 1051

**SINGle**

The active setup is reset according to the current preset mode; the name of the active setup and the parameters of all other setups remain unchanged.

**Example:** See `SYSTem:PRESet[:DUMMy]`

**Manual operation:** See "Preset Scope" on page 520

---

### **SYSTem:PRESet:START** <Boolean>

Defines whether the analyzer firmware always starts with the configured system preset (factory or user defined) or with the previous state. This is a global setting.

**Parameters:**

<Boolean>

**ON**

The FW always starts with the configured system preset.

See `SYSTem:PRESet:USER:NAME` and `SYSTem:PRESet:USER[:STATe]`.

**OFF**

The analyzer firmware recalls the previous state, i.e. the settings that were persisted during the previous shutdown.

**Manual operation:** See "Start in Preset" on page 520

---

### **SYSTem:PRESet:USER[:STATe]** <Boolean>

Determines whether a factory or a user-defined preset is performed.

This setting applies to the analyzer GUI and to the remote commands `*RST` and `SYSTem:PRESet[:DUMMy]`, if `SYSTem:PRESet:REMOte[:STATe]` is set to ON.

**Parameters:**

<Boolean>

**OFF (0)**

A factory preset is performed.

**ON (1)**

A user-defined preset is performed, if the setup file selected using `SYSTem:PRESet:USER:NAME` is available and valid. Otherwise, a factory preset is performed.

**Example:**

```
SYST:PRESet:USER:NAME 'C:\Users\Public\Documents
\Rohde-Schwarz\Vna\RecallSets\Setup_2.znx'
```

Select a setup file for the user-defined preset.

```
SYST:PRESet:USER ON
```

Enable the user-defined preset.

```
SYSTem:PRESet:REMOte ON
```

Align \*RST (and `SYSTem:PRESet`) to the user-defined preset.

```
*RST
```

Perform the user-defined preset.

**Manual operation:** See "[Preset Configuration](#)" on page 520

**SYSTem:PRESet:USER:CAL** <PresetUserCal>

Selects a calibration from the calibration pool that shall be restored during a user-defined preset.

The corresponding cal group file (<PresetUserCal>.cal) must be available in the cal pool directory

```
C:\Users\Public\Documents\Rohde-Schwarz\Vna\Calibration\Data\.
```

**Parameters:**

<PresetUserCal> Name of the cal group (i.e. the name of the cal group file without path and extension).  
Use the empty string to restore the default behavior (no preset user cal).

**Example:**

```
MMEMORY:STORE:CORRection 1, 'Ref11
Trans123.cal'
```

Adds the active user calibration to the memory pool

```
SYSTem:PRESet:USER:CAL 'Ref11 Trans123'
```

Sets the newly created cal pool member as the preset user cal.

```
SYSTem:PRESet:USER:CAL?
```

Queries for the preset user cal. Returns 'Ref11 Trans123'

```
SYSTem:PRESet:USER:CAL ''
```

Restores the default behaviour of the instrument: no preset user cal.

**Manual operation:** See "[Preset User Cal](#)" on page 425

**SYSTem:PRESet:USER:NAME** <RecallSetFile>

Specifies the name of a recall set file (\*.znx|\*.znxml) to be used for a user-defined preset.



**Parameters:**

<RecallSetFile> String parameter to specify the absolute or relative path of the recall set file to be loaded. Relative paths are evaluated relative to the current directory (see [MMEMoRY:CDIRectory](#)).

**Example:**

See [SYSTem:PRESet:USER\[:STATe\]](#)

**Manual operation:** See "[Preset Configuration](#)" on page 520

**SYSTem:SETTings:UPDate** <Activate>

Initiates an immediate update of the channel or trace settings.

The command has an effect if the analyzer operates in single sweep mode ([INITiate<Ch>:CONTInuous OFF](#)) and if the display update is switched off ([SYSTem:DISPlay:UPDate OFF](#)). In this scenario, a change of the channel or trace settings is usually not taken into account immediately. The analyzer waits until the end of the current sweep sequence and changes all settings made during the last sweep period when the next single sweep sequence is initiated. Several settings can be made en bloc, which generally saves time.

[SYSTem:SETTings:UPDate ONCE](#) causes the analyzer to apply the settings at once without waiting for the end of the current single sweep sequence. The command has no effect in continuous sweep mode or if the display update is switched on.

The settings are also updated when the continuous sweep mode is activated ([INITiate<Ch>:CONTInuous ON](#)).

**Setting parameters:**

<Activate> ONCE  
Causes an immediate update of the settings.

**Example:**

```
INIT:CONT OFF
Activate single sweep mode.
SYST:SETT:UPD ONCE
Update the settings made during the current single sweep
period.
```

**Usage:** Setting only

**SYSTem:SMATrix:OPTimization** <Unit>

Sets/gets the switch matrix route selection algorithm.

**Parameters:**

<Unit> SPEEd | PRECision  
 SPEEd – Optimizes measurement speed by minimizing the total number of switching procedures. This is highly recommended for matrices with mechanical switches.  
 PRECision – Optimizes measurement precision by always using best possible routes (according to matrix-specific route prioritization).

**SYSTem:SHUTdown** [<Unit>]

Performs a shutdown or restart of the FW or OS.

If the optional parameter <Unit> is omitted, Windows is shutdown after a time-out period of 10 seconds.

**Setting parameters:**

<Unit> HALT | REBoot | ABORt | CLOSe | REStArt

**HALT**

Windows is shutdown after a time-out period of 20 seconds

**REBoot**

Windows is restarted after a time-out period of 20 seconds

**ABORt**

Abort a Windows shutdown/restart. This can only be used during the time-out period.

**CLOSe**

Close the firmware.

**REStArt**

Restart the firmware.

**Example:**

```
SYST:SHUT
```

Switch the analyzer to standby state.

**Usage:**

Setting only

**SYSTem:SOUNd:ALARm[:STATe]** <Boolean>**SYSTem:SOUNd:STATus[:STATe]** <Boolean>

These commands switch alarm or status sounds on or off.

**Parameters:**

<Boolean> ON | OFF

```
*RST: ON
```

**Example:**

```
SYST:SOUN:ALAR OFF; STAT OFF
```

Switch alarm and status sounds off.

**Manual operation:** See "[Sounds](#)" on page 522

**SYSTem:TIME** <Hours>, <Minutes>, <Seconds>

The command queries or defines the instrument's current time setting.

The setting command requires administrator rights; refer to [Chapter 11.1.1, "Windows Operating System"](#), on page 1149.

**Parameters:**

<Hours> Range: 0...23

<Minutes> Range: 0...59

<Seconds> Range: 0...59

**Example:**            `SYST:TIME?`  
 Response: 12, 0, 0 - it is precisely 12 pm.

### **SYSTem:TRESet[:STATe] <Boolean>**

Defines the behavior of the `INITiate<Ch>[:IMMediate][:DUMMy]` and `INITiate[:IMMediate]:ALL`.

#### **Parameters:**

<Boolean>

**OFF (0)**  
 Previous trace data are preserved.

**ON (1)**  
 Previous trace data are deleted.

This is a global setting that is not affected by an instrument reset. Factory default is OFF (0).

**Manual operation:** See "[Restart: Set all Traces to 0](#)" on page 523

### **SYSTem:TSLock <Type>**

Locks the touchscreen functionality of the R&S ZND, e.g. in order to prevent inadvertent entries during remote control.

#### **Parameters:**

<Type>

OFF | DIAGrams | SCReen

OFF – touchscreen (e.g. the remote screen) remains active. You can use the buttons in "Remote" softtool panels. If you switch back to manual control, the drag and drop functions (e.g. for markers) are still available.

DIAGrams – lock the drag and drop functions in diagrams .

SCReen – lock the entire screen including the remote screen buttons.

\*RST:            n/a (\*RST does not affect the touchscreen lock setting).

**Example:**            `SYSTem:TSLock SCReen`  
 Lock the entire screen.

**Manual operation:** See "[Enabled / Lock Diagrams / Lock Screen](#)" on page 517

### **SYSTem:TTLout<Pt>:STATus[:STATe] <Boolean>**

Defines the default values of `CALCulate<Chn>:LIMit:TTLout<Pt>[:STATe]` for new traces.

#### **Suffix:**

<Pt>

1 - TTL out pass 1 (pin 13 of USER PORT connector)  
 2 - TTL out pass 2 (pin 14 of USER PORT connector)

#### **Parameters:**

<Boolean>

**OFF (0)**

New traces are created with

CALCulate<Chn>:LIMit:TTLout<Pt>[:STATe] set to OFF (0).

**ON (1)**

New traces are created with

CALCulate<Chn>:LIMit:TTLout<Pt>[:STATe] set to ON (1).

\*RST: Not affected by \*RST; factory default is OFF

**Manual operation:** See ["TTL Pass Default Values"](#) on page 528

**SYSTem:USER:DISPlay:TITLe** <String>

Defines a title for the remote display, i.e. for the screen that is shown at the instrument, if a remote session is established and the standard display is switched off.

**DON'T TOUCH**  
Remote test running...

**Parameters:**

<String> Title string.  
A \n in the string starts a new line; see example.  
\*RST: empty string

**Example:**

```
SYST:USER:DISP:TITL "DON'T TOUCH\nRemote test
running..."
```

Define a title for the remote display.

**SYSTem:USER:KEY** <Key>[, <Label>]

Labels a user-defined key in the remote display. In the query form the command returns whether or not a user-defined key was tapped or clicked.

**Parameters:**

<Key> Number of the user key  
0 – Delete all user keys and restore the default keys ("Go to Local", "Display Off").  
1 to 8 – User key numbers  
Range: 0 to 8  
\*RST: 0

<Label> Label for user key no. 1 to 8 (string variable)

**Example:**

```
SYST:USER:KEY 1, 'User S11'
```

Define a user key no. 1 labeled S11. The user key is only labeled, no functionality is assigned.

```
SYST:USER:KEY? 1
```

Query the label. The response is 1, 'User S11'.

```
SYST:USER:KEY?
```

Query the user action. The query returns 0, '', indicating that no user key has been tapped or clicked. If you tap the user soft-key no. 1, the response is 1, 'User S11'. Moreover, the ESR bit no. 6 (User Request) is set.

```
SYST:USER:KEY 0
```

Delete the user key and restore the default keys.

**SYSTem:VERSion?**

Returns the SCPI version number to which the analyzer complies. The analyzer complies to the final SCPI version 1999.0

**Example:**

```
SYST:VERS?
```

Query the SCPI version. The response is 1999.0.

**Usage:**

Query only

**8.3.18 TRACe Commands**

The TRACe . . . commands handle active trace data and trace data stored in the analyzer's internal memory.

**Trace data formats**

Trace data is transferred in either ASCII or block data (REAL) format, depending on the `FORMat[:DATA]` setting. If the block data format is used, it is recommended to select EOI as receive terminator (`SYSTem:COMMunicate:GPIB[:SELF]:RTERminator EOI`).

The commands in the TRACe... menu use the following ZVR-compatible parameters to specify traces:

Table 8-16: Reserved Trace Names

| Parameter                                                                    | Meaning                                                                                                                         | Used in                                                                                                                                   |
|------------------------------------------------------------------------------|---------------------------------------------------------------------------------------------------------------------------------|-------------------------------------------------------------------------------------------------------------------------------------------|
| CH1DATA<br>CH2DATA<br>CH3DATA<br>CH4DATA                                     | Active data trace of channels 1 to 4                                                                                            | TRACe:COPIY<br>TRACe[:DATA]:STIMulus[:ALL]?<br>TRACe[:DATA][:RESPonse][:ALL]?<br>CALCulate<Chn>:MATH[:EXPRession][:DEFine]                |
| CH1MEM<br>CH2MEM<br>CH3MEM<br>CH4MEM                                         | Active memory trace associated to the active data trace CH1DATA, CH2DATA, CH3DATA, CH4DATA, respectively.                       | TRACe[:DATA]:STIMulus[:ALL]?<br>TRACe[:DATA][:RESPonse][:ALL]?                                                                            |
| IMPLied                                                                      | Active data trace, addressed with <Chn>                                                                                         | CALCulate<Chn>:MATH[:EXPRession][:DEFine]                                                                                                 |
| CHMem                                                                        | Active memory trace assigned to the IMPLied trace                                                                               | CALCulate<Chn>:MATH[:EXPRession][:DEFine]                                                                                                 |
| MDATA1<br>MDATA2<br>MDATA3<br>MDATA4<br>MDATA5<br>MDATA6<br>MDATA7<br>MDATA8 | Memory trace named Mem<n> [Trc<m>]. The trace name is unique because <n> counts all data and memory traces in the active setup. | TRACe:CLEAr<br>TRACe:COPIY<br>TRACe[:DATA]:STIMulus[:ALL]?<br>TRACe[:DATA][:RESPonse][:ALL]?<br>CALCulate<Chn>:MATH[:EXPRession][:DEFine] |

**TRACe:COPIY** <MemTraceName>, <DataTraceName>

Copies a data trace to a memory trace. The trace to be copied can be specified by two alternative methods:

- As the active data trace of channels 1 to 4 (CH1DATA, CH2DATA, CH3DATA, CH4DATA). If a mathematical trace is active, the associated data trace is copied.
- As a trace with a name (string variable).

The created memory trace can be specified as follows:

- As the memory trace named Mem<n> [Trc<m>], where n = 1, ... 8 and Trc<m> is the name of the copied data trace (MDATA1, MDATA2, MDATA3, MDATA4, MDATA5, MDATA6, MDATA7, MDATA8).
- As a memory trace with an arbitrary name (string variable).

An existing memory trace with the same name is overwritten.

**Note:** The copied trace is the data trace which is not modified by any mathematical operations. To copy a mathematical trace to a memory trace, use **TRACe:COPIY:MATH**. To copy the active trace to the memory using an automatic memory trace name, use **CALCulate<Chn>:MATH:MEMorize**.

**Setting parameters:**

- <MemTraceName>** Name of the memory trace (see also [Table 8-16](#)).
- Range: <memory\_trace> is either a string variable (enclosed in single or double quotes) or one of the following reserved names (no string variables): MDATA1 | MDATA2 | MDATA3 | MDATA4 | MDATA5 | MDATA6 | MDATA7 | MDATA8 (only for memory traces Mem<n>[Trc<m>], where n = 1, ... 8).
- <DataTraceName>** Name of the data trace (see also [Table 8-16](#)).
- Range: <data\_trace> is either a string variable (enclosed in single or double quotes) or one of the following reserved names (no string variables): CH1DATA | CH2DATA | CH3DATA | CH4DATA (only for the active data trace in channels Ch1, Ch2, Ch3, Ch4).

**Example:**

```
*RST; :SWE:POIN 20
Create a trace with 20 sweep points, making the created trace
the active trace of channel 1 (omitted optional mnemonic
SENSE1).
TRAC:COPY "Mem_Pt20", CH1DATA
Copy the current state of the created trace to a memory trace
named "Mem_Pt20". The memory trace is not displayed.
DISP:WIND:TRAC2:FEED "MEM_PT20"
Display the created memory trace in the active diagram area
(diagram area no. 1).
```

**Usage:** Setting only

**Manual operation:** See "[Data to <Destination>](#)" on page 271

**TRACe:COPIY:MATH <MemTraceName>, <DataTraceName>**

Copies a mathematical trace to a memory trace. The trace to be copied can be specified by two alternative methods:

- As the active mathematical trace of channels 1 to 4 (CH1DATA, CH2DATA, CH3DATA, CH4DATA)
- As a trace with a name (string variable).

The created memory trace can be specified as follows:

- As the memory trace named Mem<n>[Trc<m>], where n = 1, ... 8 and Trc<m> is the name of the copied data trace (MDATA1, MDATA2, MDATA3, MDATA4, MDATA5, MDATA6, MDATA7, MDATA8).
- As a memory trace with an arbitrary name (string variable).

An existing memory trace with the same name is overwritten.

**Note:** To copy a data trace which is not modified by any mathematical operations, use [TRACe:COPIY](#)

**Setting parameters:**

- <MemTraceName>** Name of the memory trace (see also [Table 8-16](#)).
- Range: <memory\_trace> is either a string variable (enclosed in single or double quotes) or one of the following reserved names (no string variables): MDATA1 | MDATA2 | MDATA3 | MDATA4 | MDATA5 | MDATA6 | MDATA7 | MDATA8 (only for memory traces Mem<n>[Trc<m>], where n = 1, ... 8).
- <DataTraceName>** Name of the data trace (see also [Table 8-16](#)).
- Range: <data\_trace> is either a string variable (enclosed in single or double quotes) or one of the following reserved names (no string variables): CH1DATA | CH2DATA | CH3DATA | CH4DATA (only for the active data trace in channels Ch1, Ch2, Ch3, Ch4).

**Example:**

```
*RST; :SWE:POIN 20
Create a trace with 20 sweep points, making the created trace
the active trace of channel 1 (omitted optional mnemonic
SENSE1).
CALC:MATH:SDEF 'Trc1 / 2'; :CALC:MATH:STAT ON
Define a mathematical trace, dividing the data trace by 2. Acti-
vate the mathematical mode and display the mathematical trace
instead of the data trace.
TRAC:COPY:MATH 'Mem_Pt20',CH1DATA; :CALC:MATH:
STAT OFF
Copy the current state of the mathematical trace to a memory
trace named "Mem_Pt20". The memory trace is not displayed.
Switch the display back to the data trace.
DISP:WIND:TRAC2:FEED 'MEM_PT20'
Display the created memory trace together with the data trace.
```

**Usage:** Setting only

## 8.3.19 TRIGger Commands

### 8.3.19.1 TRIGger[:SEquence]...

The TRIGger[:SEquence]... commands synchronize the analyzer's measurement sequences to external events. These events are indicated to the VNA by sending trigger signals via EXT TRIG IN or the USER PORT.

|                                                 |      |
|-------------------------------------------------|------|
| TRIGger<Ch>[:SEquence]:HOLDoff.....             | 1061 |
| TRIGger<Ch>[:SEquence]:LINK.....                | 1061 |
| TRIGger<Ch>[:SEquence]:MULTiple:HOLDoff.....    | 1062 |
| TRIGger<Ch>[:SEquence]:MULTiple:SLOPe<Num>..... | 1062 |



|                                             |      |
|---------------------------------------------|------|
| TRIGger<Ch>[:SEquence]:MULTiple:SOURce..... | 1063 |
| TRIGger<Ch>[:SEquence]:SLOPe.....           | 1063 |
| TRIGger<Ch>[:SEquence]:SOURce.....          | 1064 |

---

### TRIGger<Ch>[:SEquence]:HOLDoff <DelayTime>

Sets a delay time between the trigger event and the start of the measurement ("Trigger Delay").

**Suffix:**

<Ch> Channel number.

**Parameters:**

<DelayTime> Delay time.  
 Range: 0 s to 13680 s  
 Increment: 10 ms  
 \*RST: 0 s  
 Default unit: s

**Example:**

```
TRIG:SOUR MAN
Activate external trigger source.
TRIG:HOLD UP
Set a delay time of 10 ms.
```

**Manual operation:** See "Delay" on page 368

---

### TRIGger<Ch>[:SEquence]:LINK <MeasSequence>

Selects the triggered measurement sequence. The identifier for the sequence is a string variable.

**Suffix:**

<Ch> Channel number

**Parameters:**

<MeasSequence> Triggered measurement sequence, string variable.  
 'SWEep' – trigger event starts an entire sweep.  
 'SEGment' – trigger event starts a sweep segment, if segmented frequency sweep is active (see example below). If another sweep type is active, the trigger event starts an entire sweep.  
 'POINT' – trigger event starts measurement at the next sweep point.  
 'PPOINT' – trigger event starts the next partial measurement at the current or at the next sweep point.  
 \*RST: 'SWEep'

**Example:**

```
SEGM:ADD; :SWE:TYPE SEGM
Select segmented frequency sweep.
TRIG:LINK 'SEGM'
Select a trigger segment as triggered measurement sequence.
TRIG:LINK?
Query the triggered measurement sequence. The response is
'SEGMENT'.
```

**Manual operation:** See "[Sequence](#)" on page 367

**TRIGger<Ch>[:SEQuence]:MULTiple:HOLDoff <MeasSequence>[, <DelayTime>]**

Sets a delay time between the trigger event and the start of the measurement ("Trigger Delay") in multiple trigger mode.

**Suffix:**

<Ch> Channel number

**Parameters:**

<MeasSequence> SWEep | SEGment | POINt | PPOint  
Triggered measurement sequence, PPOint denotes "partial measurement"; see [TRIGger<Ch>\[:SEQuence\]:LINK](#).

<DelayTime> Delay time  
Range: 0 s to 13680 s  
Increment: 10 ms  
\*RST: 0 s  
Default unit: s

**Example:** See [TRIGger<Ch>\[:SEQuence\]:MULTiple:SOURce](#)

**Manual operation:** See "[.../Source/...](#)" on page 369

**TRIGger<Ch>[:SEQuence]:MULTiple:SLOPe<Num> <MeasSequence>[, <Slope>]**

Qualifies whether the multiple trigger events occur on the rising or on the falling edge or on the beginning of the high / low level periods of the external TTL trigger signal <Num>.

**Suffix:**

<Ch> Channel number

<Num> Number of trigger signal (1 or 2)

**Parameters:**

<MeasSequence> SWEep | SEGment | POINt | PPOint  
Triggered measurement sequence, PPOint denotes "partial measurement"; see [TRIGger<Ch>\[:SEQuence\]:LINK](#).

<Slope> POSitive | NEGative | HIGH | LOW  
Trigger slope for the triggered measurement sequence:  
POSitive | NEGative - rising or falling edge  
HIGH | LOW - high or low level

**Example:** See [TRIGger<Ch>\[:SEquence\]:MULTiple:SOURce](#)

**Manual operation:** See "[... /Source/ ...](#)" on page 369

---

**TRIGger<Ch>[:SEquence]:MULTiple:SOURce** <Sequence>[, <TrigSource>]

Selects the source of the trigger events the analyzer uses to start a measurement sequence in multiple trigger mode ([TRIGger<Ch>\[:SEquence\]:SOURce MULTiple](#)).

**Suffix:**

<Ch> Channel number

**Parameters:**

<Sequence> SWEep | SEGment | POINT | PPOINT  
 Triggered measurement sequence  
 PPOINT denotes "partial measurement"; see [TRIGger<Ch>\[:SEquence\]:LINK](#).

<TrigSource> IMMEDIATE | EXT1 | EXT2 | E1A2 | E1O2 | MANUAL  
 Trigger source for the triggered measurement sequence

**IMMEDIATE**

Free run measurement (untriggered)

**EXT1**

Trigger event at EXT TRIG IN or Pin 2 of [USER PORT](#)

**EXT2**

Trigger event at pin 25 of [USER PORT](#).

**E1A2**

Trigger events at EXT1 **AND** EXT2

**E1O2**

Trigger event at EXT1 **OR** EXT2

**MANUAL**

Trigger event generated by pressing the "Manual Trigger" soft-key

**Example:**

```
TRIG:MULT:SOUR SWE, EXT1; SOUR POIN, EXT2
Select external trigger 1 as a trigger source for the entire sweep,
external trigger 2 as a trigger source for each point.
TRIG:MULT:SLOP1 SWE, POS; SLOP2 POIN, POS
Trigger on the rising edges of the external trigger signals 1 and
2.
TRIG:MULT:HOLD POIN, 1ms
Define a trigger delay of 1 ms before each sweep point.
```

**Manual operation:** See "[... /Source/ ...](#)" on page 369

---

**TRIGger<Ch>[:SEquence]:SLOPe** <Slope>

Qualifies whether the trigger event occurs on the rising or on the falling edge or on the beginning of the high / low level periods of the external TTL trigger signal.

|                          |                                                                                                                                                                             |
|--------------------------|-----------------------------------------------------------------------------------------------------------------------------------------------------------------------------|
| <b>Suffix:</b>           |                                                                                                                                                                             |
| <Ch>                     | Channel number                                                                                                                                                              |
| <b>Parameters:</b>       |                                                                                                                                                                             |
| <Slope>                  | POSitive   NEGative   HIGH   LOW<br>Trigger slope for the triggered measurement sequence:<br>POSitive   NEGative - rising or falling edge<br>HIGH   LOW - high or low level |
| <b>Example:</b>          | TRIG:SOUR EXT<br>Activate external signal as trigger source.<br>TRIG:SLOP NEG<br>Trigger on the negative edge of the (external TTL) trigger signal.                         |
| <b>Manual operation:</b> | See " <a href="#">Signal Type</a> " on page 368                                                                                                                             |

---

### TRIGger<Ch>[:SEquence]:SOURce <TrigSource>

Selects the source of the trigger events that the analyzer uses to start a measurement sequence.

|                          |                                                                                                                                                                                                                                                                                                                                                                                                                                       |
|--------------------------|---------------------------------------------------------------------------------------------------------------------------------------------------------------------------------------------------------------------------------------------------------------------------------------------------------------------------------------------------------------------------------------------------------------------------------------|
| <b>Suffix:</b>           |                                                                                                                                                                                                                                                                                                                                                                                                                                       |
| <Ch>                     | Channel number                                                                                                                                                                                                                                                                                                                                                                                                                        |
| <b>Parameters:</b>       |                                                                                                                                                                                                                                                                                                                                                                                                                                       |
| <TrigSource>             | IMMediate   EXTernal   MANual   MULTiple<br><b>IMMediate</b><br>Free run measurement (untriggered)<br><b>EXTernal</b><br>Trigger by external signal applied to the EXT TRIG IN connector or pin 2 of the USER PORT on the rear panel.<br><b>MANual</b><br>Trigger event generated by pressing the "Manual Trigger" soft-key<br><b>MULTiple</b><br>Multiple trigger mode, configured by<br>TRIGger<Ch>[:SEquence]:MULTiple... commands |
| <b>Example:</b>          | TRIG:SOUR MAN<br>Activate manual trigger mode. The analyzer starts the next measurement sequence when the "Manual Trigger" button is pressed.                                                                                                                                                                                                                                                                                         |
| <b>Manual operation:</b> | See " <a href="#">FreeRun / External / Manual / Multiple Triggers</a> " on page 366                                                                                                                                                                                                                                                                                                                                                   |

#### 8.3.19.2 TRIGger:CHANnel:AUXiliary...

The TRIGger:CHANnel<Ch>:AUXiliary... commands control the external trigger output EXT TRIG OUT at the rear panel of the instrument. The output trigger signal

consists of TTL pulses of configurable duration and polarity which can be sent before or after each sweep or measurement point.

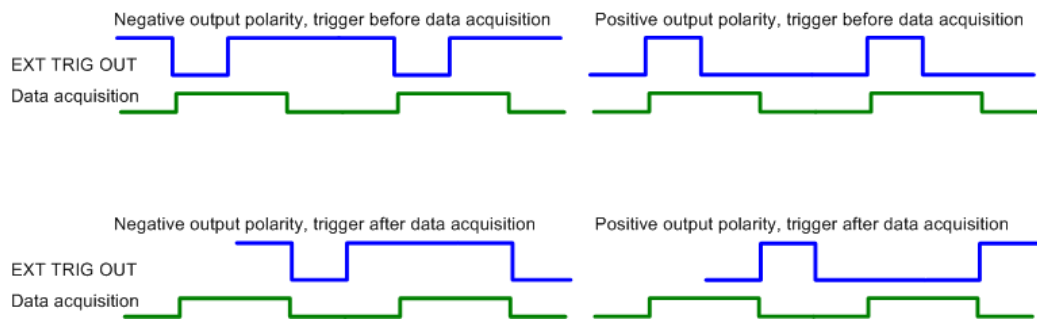

**Figure 8-1: Output trigger signal at EXT TRIG OUT**

|                                            |      |
|--------------------------------------------|------|
| TRIGger:CHANnel<Ch>:AUXiliary<n>[:ENABLE]  | 1065 |
| TRIGger:CHANnel<Ch>:AUXiliary<n>:DURation  | 1065 |
| TRIGger:CHANnel<Ch>:AUXiliary<n>:INTerval  | 1066 |
| TRIGger:CHANnel<Ch>:AUXiliary<n>:OPOLarity | 1066 |
| TRIGger:CHANnel<Ch>:AUXiliary<n>:POSition  | 1067 |

---

#### TRIGger:CHANnel<Ch>:AUXiliary<n>[:ENABLE] <EnableTriggOut>

Turns the external trigger output EXT TRIG OUT for channel no. <Ch> on or off.

##### Suffix:

|      |                                                                                  |
|------|----------------------------------------------------------------------------------|
| <Ch> | Channel number                                                                   |
| <n>  | Auxiliary channel number. This suffix is ignored; it can be set to 1 or omitted. |

##### Parameters:

|                  |                                                      |
|------------------|------------------------------------------------------|
| <EnableTriggOut> | Turn trigger output on (ON) or off (OFF, no signal). |
| *RST:            | OFF                                                  |

##### Example:

```
TRIGger:CHANnel:AUXiliary:ENABLE ON
Turn on the trigger output for channel no. 1 (channel suffix omitted).
TRIGger:CHANnel:AUXiliary:DURation 10 us
Change the width of the output trigger pulses.
TRIGger:CHANnel:AUXiliary:POSition BEFORE
Send the output trigger pulses before data acquisition starts.
TRIGger:CHANnel:AUXiliary:INTerval SWEEp
Send one output trigger pulse per sweep.
TRIGger:CHANnel:AUXiliary:OPOLarity POSitive
Select positive polarity for the output trigger pulses.
```

---

#### TRIGger:CHANnel<Ch>:AUXiliary<n>:DURation <TrigOutDuration>

Specifies the width of the output trigger pulses at EXT TRIG OUT.

The trigger duration must be shorter than the selected sweep interval (see [TRIGger:CHANnel<Ch>:AUXiliary<n>:INTerval](#)).

If the trigger duration is too long, you can modify one of the following settings:

- Reduce the trigger duration, if possible.
- Slow down the sweep: select a smaller bandwidth or increase the "Sweep Time" setting.

**Suffix:**

<Ch> Channel number

<n> Auxiliary channel number. This suffix is ignored; it can be set to 1 or omitted.

**Parameters:**

<TrigOutDuration> Pulse width between 1 µs (1E-6 s) and 1 s.

\*RST: 1 us

Default unit: s

**Example:**

See [TRIGger:CHANnel<Ch>:AUXiliary<n>\[:ENABLE\]](#) on page 1065

**TRIGger:CHANnel<Ch>:AUXiliary<n>:INTerval <Type>**

Specifies whether the trigger output pulses are sent once every measurement point or once every sweep.

**Suffix:**

<Ch> Channel number

<n> Auxiliary channel number. This suffix is ignored; it can be set to 1 or omitted.

**Parameters:**

<Type> POINT | SWEep

**ACquisition**

A trigger out signal is generated for every data acquisition phase

\*RST: SWEep

**Example:**

See [TRIGger:CHANnel<Ch>:AUXiliary<n>\[:ENABLE\]](#)

**TRIGger:CHANnel<Ch>:AUXiliary<n>:OPOLarity <Type>**

Selects the polarity of the output trigger pulses; see [Figure 8-1](#).

**Suffix:**

<Ch> Channel number

<n> Auxiliary channel number. This suffix is ignored; it can be set to 1 or omitted.

**Parameters:**

<Type>                    POSitive | NEGative  
 \*RST:                    NEGative

**Example:**                See `TRIGger:CHANnel<Ch>:AUXiliary<n>[:ENABLE]`

**TRIGger:CHANnel<Ch>:AUXiliary<n>:POSITION <Type>**

Specifies whether the trigger output pulse is sent before or after the selected sweep interval (see `TRIGger:CHANnel<Ch>:AUXiliary<n>:INTerval`).

**Suffix:**

<Ch>                      Channel number  
 <n>                        Auxiliary channel number. This suffix is ignored; it can be set to 1 or omitted.

**Parameters:**

<Type>                    BEFore | AFTer

**BEFore**

is appropriate if the device needs to be triggered before the data is acquired (typical example: a power meter which is used for power calibration)

**AFTer**

is appropriate if the device needs to be triggered just after data acquisition (typical example: an external generator which must be reconfigured to get ready for the next measurement)

\*RST:                    AFTer

**Example:**                See `TRIGger:CHANnel<Ch>:AUXiliary<n>[:ENABLE]` on page 1065

## 8.4 HUMS and Service Date Commands

This section provides the commands that are related to the Rohde & Schwarz [Health and Usage Monitoring Service \(HUMS\)](#), which is available on various Rohde & Schwarz instruments.



For background information, see the R&S HUMS User Manual.

- [SNMP/REST commands](#).....1068
- [System Information Commands](#).....1071
- [Device tags commands](#).....1081
- [Utilization commands](#).....1082
- [Service date commands](#).....1085

### 8.4.1 SNMP/REST commands

These commands configure the SNMP and REST interfaces to R&S HUMS.

They all require software option R&S ZND-980.

|                                                                   |      |
|-------------------------------------------------------------------|------|
| <a href="#">SYSTem:COMMunicate:SNMP:COMMunity:RO</a> .....        | 1068 |
| <a href="#">SYSTem:COMMunicate:SNMP:COMMunity:RW</a> .....        | 1068 |
| <a href="#">SYSTem:COMMunicate:SNMP:CONtact</a> .....             | 1069 |
| <a href="#">SYSTem:COMMunicate:SNMP:LOCation</a> .....            | 1069 |
| <a href="#">SYSTem:COMMunicate:SNMP:USM:USER</a> .....            | 1069 |
| <a href="#">SYSTem:COMMunicate:SNMP:USM:USER:ALL?</a> .....       | 1070 |
| <a href="#">SYSTem:COMMunicate:SNMP:USM:USER:DELete</a> .....     | 1070 |
| <a href="#">SYSTem:COMMunicate:SNMP:USM:USER:DELete:ALL</a> ..... | 1070 |
| <a href="#">SYSTem:COMMunicate:SNMP:VERSion</a> .....             | 1070 |
| <a href="#">SYSTem:COMMunicate:REST:ENABle</a> .....              | 1071 |

---

#### **SYSTem:COMMunicate:SNMP:COMMunity:RO** <CommunityString>

This command sets the SNMP community string for read-only access.

Prerequisites for this command:

- Select an SNMP version that supports communities ([SYSTem:COMMunicate:SNMP:VERSion](#) on page 1070).

#### **Setting parameters:**

<CommunityString> String containing the community name.

**Example:**           //Set community name  
 SYST:COMM:SNMP:VERS V12  
 SYST:COMM:SNMP:COMM:RO 'ABC'

**Usage:**             Setting only

**Manual operation:** See "[SNMPv2c Configuration](#)" on page 531

---

#### **SYSTem:COMMunicate:SNMP:COMMunity:RW** <CommunityString>

This command sets the SNMP community string for read-write access.

Prerequisites for this command:

- Select an SNMP version that supports communities ([SYSTem:COMMunicate:SNMP:VERSion](#) on page 1070).

#### **Setting parameters:**

<CommunityString> String containing the community name.

**Example:**           //Set read-write access  
 SYST:COMM:SNMP:VERS V12  
 SYST:COMM:SNMP:COMM:RW 'ABC'

**Usage:**             Setting only

**Manual operation:** See "[SNMPv2c Configuration](#)" on page 531



**SYSTem:COMMunicate:SNMP:CONtact** <SnmSysContact>

This command sets the SNMP contact information for the administrator.

Not setting the contact information via SCPI persistently allows to change the string via SNMP.

**Parameters for setting and query:**

<SnmSysContact> String containing SNMP contact.  
\*RST: "" (empty string)

**Example:** //Set SNMP sysContact  
SYST:COMM:SNMP:CONT 'ABC'

**SYSTem:COMMunicate:SNMP:LOCation** <SnmSysLocation>**SYSTem:COMMunicate:SNMP:LOCation?** <SnmSysLocation>

This command sets the SNMP location information for the administrator.

Not setting the contact information via SCPI persistently allows to change this string via SNMP.

**Parameters for setting and query:**

<SnmSysLocation> String containing SNMP location.  
\*RST: "" (empty string)

**Example:** //Return SNMP location  
SYST:COMM:SNMP:LOC?

**SYSTem:COMMunicate:SNMP:USM:USER** <Name>, <Access>, <Level>[, <Auth\_pwd>[, <Priv\_pwd>]]

This command defines a SNMP user profile.

Prerequisites for this command:

- Select SNMPv3 ([SYSTem:COMMunicate:SNMP:VERSion](#) on page 1070).

**Setting parameters:**

<Name> String containing name of the user.  
<Access> RO | RW  
Defines the access right a user can have.  
<Level> NOAuth | AUTH | PRIVacy  
Defines the security level.  
<Auth\_pwd> String containing the authentication password.  
<Priv\_pwd> String containing the privacy password.

**Example:** //Create user profile  
SYST:COMM:SNMP:VERS V123  
SYST:COMM:SNMP:USM:USER 'Peter', 'RO', 'PRIV',  
'1234', 'XYZ'

**Usage:** Setting only

**Manual operation:** See ["SNMPv3 Configuration"](#) on page 532

### **SYSTem:COMMunicate:SNMP:USM:USER:ALL?**

This command returns the number of users and a list of all SNMP users for SNMPv3.

Prerequisites for this command:

- Select SNMPv3 ([SYSTem:COMMunicate:SNMP:VERSion](#) on page 1070).

#### **Return values:**

<Count> Total number of registered SNMP users.

<Name> List of all user names as a comma-separated list.

**Example:** //Return all SNMP users  
SYST:COMM:SNMP:USM:USER:ALL?

**Usage:** Query only

**Manual operation:** See ["SNMPv3 Configuration"](#) on page 532

### **SYSTem:COMMunicate:SNMP:USM:USER:DELeTe <UserName>**

This command deletes a specific SNMP user profile.

#### **Setting parameters:**

<UserName> String containing name of SNMP user profile to be deleted.

**Example:** //Delete SNMP user profile  
SYST:COMM:SNMP:USM:USER:DEL "Peter"

**Usage:** Setting only

**Manual operation:** See ["SNMPv3 Configuration"](#) on page 532

### **SYSTem:COMMunicate:SNMP:USM:USER:DELeTe:ALL**

This command deletes all SNMP user profiles.

**Example:** //Delete all SNMP user profiles  
SYST:COMM:SNMP:USM:USER:DEL:ALL

**Usage:** Event

**Manual operation:** See ["SNMPv3 Configuration"](#) on page 532

### **SYSTem:COMMunicate:SNMP:VERSion <SnpVersion>** **SYSTem:COMMunicate:SNMP:VERSion? <SnpVersion>**

This command selects the SNMP version.

#### **Parameters for setting and query:**

<SnpVersion> OFF | V12 | V123 | V3 | DEFault

**OFF**

SNMP communication is off.

**V12**

SNMP communication with SNMPv2 or lower.

**V123**

SNMP communication with SNMPv2 and SNMPv3.

**V3**

SNMP communication with SNMPv3.

**\*RST:** V123

**Example:** //Select the SNMP version  
 SYST:COMM:SNMP:VERS V12

**Manual operation:** See "[SNMP](#)" on page 531

**SYSTem:COMMunicate:REST:ENABle** <RestState>

This command returns information about the HUMS REST status and enables or disables the public HUMS REST endpoints.

**Parameters:**

<RestState> ON | OFF | 0 | 1

**Example:** //Return REST state  
 SYST:COMM:REST:ENAB?

**Manual operation:** See "[REST](#)" on page 531

## 8.4.2 System Information Commands

Using these commands you can retrieve the system information provided by the R&S HUMS.

They all require software option R&S ZND-980.

|                                           |      |
|-------------------------------------------|------|
| DIAGnostic:HUMS[:ALL]?                    | 1072 |
| DIAGnostic:HUMS:BIOS?                     | 1072 |
| DIAGnostic:HUMS:DELeTe:ALL                | 1073 |
| DIAGnostic:HUMS:DEVice:HISTory?           | 1073 |
| DIAGnostic:HUMS:DEVice:HISTory:DELeTe:ALL | 1074 |
| DIAGnostic:HUMS:EQUipment?                | 1074 |
| DIAGnostic:HUMS:FORMat                    | 1075 |
| DIAGnostic:HUMS:SAVE                      | 1075 |
| DIAGnostic:HUMS:SECurity?                 | 1075 |
| DIAGnostic:HUMS:SERVice?                  | 1076 |
| DIAGnostic:HUMS:STATe                     | 1077 |
| DIAGnostic:HUMS:STORAge?                  | 1077 |
| DIAGnostic:HUMS:SW?                       | 1078 |
| DIAGnostic:HUMS:SYSTem:INFO?              | 1079 |
| DIAGnostic:HUMS:SYSTem:STATus?            | 1079 |
| DIAGnostic:HUMS:SYSTem:STATus:SUMMary?    | 1080 |

**DIAGnostic:HUMS[:ALL]?**

This command returns the REST endpoints for the HUMS application in a single query. This allows you to read all HUMS data stored on the instrument via REST API.

The data can be displayed either in `JSON` or `XML` format. For more information about setting the format, see [DIAGnostic:HUMS:FORMat](#) on page 1075.

**Return values:**

`<Endpoints>`                    `<block_data>`

String returns REST endpoints as block data in a comma-separated list.

Binary block data with the following syntax:

```
#<Digits><Length><Binarydata>
```

**#**

Indicates the start of the binary block

**<Digits>**

Decimal value

Gives the number of decimal digits used for the `<Length>` value

**<Length>**

Decimal value

Number of bytes the follow in the `<Binary data>` part

**<Binary data>**

Binary data in ASCII format

**Example:**                    `//Return complete HUMS data`  
`DIAG:HUMS?`

**Usage:**                    Query only

**DIAGnostic:HUMS:BIOS?**

This command returns the BIOS information from the instrument. Depending on the set data format, the queried data is either displayed in `XML` or `JSON` format. For more information about setting the data format, see [DIAGnostic:HUMS:FORMat](#) on page 1075.

**Return values:**

`<BIOSInfo>`                    `<block_data>`

BIOS information of the connected instrument as block data in a comma-separated list.

```
#<manufacturer>,<serialNumber>,<version>,<releaseDate>,<caption>,<isPresent>
```

Binary block data with the following syntax:

```
#<Digits><Length><Binarydata>
```

**#**

Indicates the start of the binary block

**<Digits>**

Decimal value

Gives the number of decimal digits used for the `<Length>` value

**<Length>**

Decimal value

Number of bytes the follow in the &lt;Binary data&gt; part

**<Binary data>**

Binary data in ASCII format

**Example:** //Return BIOS information  
DIAG:HUMS:BIOS?

**Usage:** Query only

**DIAGnostic:HUMS:DELeTe:ALL**

This command deletes the complete HUMS data. This includes device history, device tags, SCPI connections, utilization history and utilizations.

**Example:** //Delete HUMS data  
DIAG:HUMS:DEL:ALL

**Usage:** Event

**Manual operation:** See "[Delete HUMS History](#)" on page 531

**DIAGnostic:HUMS:DEvIce:HISTory?**

This command returns the device history information of the connected instrument. Depending on the set data format, the queried data is either displayed in XML or JSON format. For more information about setting the data format, see [DIAGnostic:HUMS:FORMat](#) on page 1075.

**Return values:**

<HistoryInfo> <block\_data>  
Device history information of the connected instrument as block data in a comma-separated list:  
#blockdata[{event1},{event2},{event3}...]   
With the following parameters:  
<eventID>,<eventTimestamp>,<eventMessage>,  
<eventDetails>,<eventSeverity>  
Binary block data with the following syntax:  
#<Digits><Length><Binarydata>  
#  
Indicates the start of the binary block  
**<Digits>**  
Decimal value  
Gives the number of decimal digits used for the <Length> value  
**<Length>**  
Decimal value  
Number of bytes the follow in the <Binary data> part  
**<Binary data>**  
Binary data in ASCII format

**Example:** //Return device history  
 DIAG:HUMS:DEV:HIST?  
**Returns for example:**  
 #44715[{"eventId":32,"eventTimestamp":  
 "2021-02-02T17:25:39Z","eventMessage":  
 "Deviation from Self Alignment Temperature",  
 "eventDetails":  
 "Deviations resolved","eventSeverity":0}

**Usage:** Query only

#### DIAGnostic:HUMS:DEvIce:HISTory:DELeTe:ALL

This command deletes the complete device history information of the connected instrument.

**Example:** //Delete complete device history  
 DIAG:HUMS:DEV:HIST:DEL:ALL

**Usage:** Event

#### DIAGnostic:HUMS:EQUipment?

This command returns the equipment information (device footprint) of the instrument. Depending on the set data format, the queried data is either displayed in XML or JSON format. For more information about setting the data format, see [DIAGnostic:HUMS:FORMat](#) on page 1075.

##### Return values:

<EquipmentInfo> <block\_data>  
 Device footprint of the connected instrument as block data in a comma-separated list.  
 Binary block data with the following syntax:  
 #<Digits><Length><Binarydata>  
**#**  
 Indicates the start of the binary block  
**<Digits>**  
 Decimal value  
 Gives the number of decimal digits used for the <Length> value  
**<Length>**  
 Decimal value  
 Number of bytes the follow in the <Binary data> part  
**<Binary data>**  
 Binary data in ASCII format

**Example:** //Return device footprint  
 DIAG:HUMS:EQU?

**Usage:** Query only

**DIAGnostic:HUMS:FORMat** <DataFormat>

This command defines the format for the queried HUMS data. You can query the HUMS data either in `JSON` format or `XML` format.

The defined format affects all other commands that return block data.

**Parameters:**

<DataFormat>      `JSON | XML`

**JSON**  
Returns the HUMS data in `JSON` format.

**XML**  
Returns the HUMS data in `XML` format.

\*RST:            `JSON`

**Example:**

```
//Return data in JSON format
DIAG:HUMS:FORM JSON
```

**DIAGnostic:HUMS:SAVE**

This command saves the HUMS history as a `ZIP` file to your preferred path.

**Example:**

```
//Save HUMS history data
DIAG:HUMS:SAVE 'C:\HUMS\hums_2021.zip'
```

**Usage:**

Event

**DIAGnostic:HUMS:SECurity?**

This command returns the security information of the instrument. Depending on the set data format, the queried data is either displayed in `XML` or `JSON` format. For more information about setting the data format, see [DIAGnostic:HUMS:FORMat](#) on page 1075.

**Return values:**

<SecurityInfo>      <block\_data>

Security information of the connected instrument as block data in a comma-separated list.

```
#blockdata{"antimalware":
{<name>,<enabled>,<upToDate>,<timestamp>},
"firewallEnabled"}
```

Binary block data with the following syntax:

```
#<Digits><Length><Binarydata>
```

**#**  
Indicates the start of the binary block

**<Digits>**  
Decimal value  
Gives the number of decimal digits used for the <Length> value

**<Length>**  
Decimal value

Number of bytes the follow in the <Binary data> part

**<Binary data>**

Binary data in ASCII format

**Example:** //Return security information  
 DIAG:HUMS:SEC?  
 #3133{"antimalware":{"name":  
 "Windows Defender", "enabled":false, "upToDate":  
 true, "timestamp":  
 "2018-02-08T10:09:22Z"}, "firewallEnabled":true}

**Usage:** Query only

**DIAGnostic:HUMS:SERVICE?**

This command returns the service information of the instrument. Depending on the set data format, the queried data is either displayed in XML or JSON format. For more information about setting the data format, see [DIAGnostic:HUMS:FORMat](#) on page 1075.

**Return values:**

<ServiceInfo> <block\_data>  
 Service information of the connected instrument as block data in a comma-separated list:  
 #blockdata{<lastdate>,<requiredservice>,<calibration>:  
 {<lastcalibration>,<nextDue>,<nextDueExpired>,  
 <recommendedCalibrationInterval>},<uptime>}  
 Binary block data with the following syntax:  
 #<Digits><Length><Binarydata>  
 #  
 Indicates the start of the binary block  
**<Digits>**  
 Decimal value  
 Gives the number of decimal digits used for the <Length>  
 value  
**<Length>**  
 Decimal value  
 Number of bytes the follow in the <Binary data> part  
**<Binary data>**  
 Binary data in ASCII format

**Example:** //Return service information  
 DIAG:HUMS:SERV?  
 Returns for example:  
 #3196{"last":"2021-01-19T23:00:00Z", "required":  
 2, "calibration":{"last":  
 "2021-01-19T23:00:00Z", "nextDue":  
 "2022-01-19T23:00:00Z", "nextDueExpired":  
 false, "recommendedCalibrationInterval":  
 "1Y"}, "uptime":0}

**Usage:** Query only



**DIAGnostic:HUMS:STATe** <State>

This command turns the HUMS service and data collection on and off.

**Parameters:**

<State> ON | OFF | 1 | 0  
\*RST: ON

**Example:** //Turn on HUMS service  
DIAG:HUMS:STAT ON

**Manual operation:** See "[State \(Device Utilization\)/Status](#)" on page 530

**DIAGnostic:HUMS:STORage?**

This command returns the storage information of the instrument. Depending on the set data format, the queried data is either displayed in XML or JSON format. For more information about setting the data format, see [DIAGnostic:HUMS:FORMat](#) on page 1075.

**Return values:**

<StorageInfo> <block\_data>  
Returns storage information for each storage device of the connected instrument as block data.  
#blockdata[{storagedevice1},  
{storagedevice2},...]  
Binary block data with the following syntax:  
#<Digits><Length><Binarydata>  
#  
Indicates the start of the binary block  
**<Digits>**  
Decimal value  
Gives the number of decimal digits used for the <Length> value  
**<Length>**  
Decimal value  
Number of bytes the follow in the <Binary data> part  
**<Binary data>**  
Binary data in ASCII format  
For each storage device it returns:  
<diskname>,<temperature>,<type>,<modelfamily>,  
<model>,<serialnumber>,<id>,<firmwareversion>,  
<capacity>,<sectorsize>,<rotationrate>,<formfactor>,  
<ataversion>,<sataversion>,<smartdatatable>.  
For each value of the smart data table it returns:  
<id>,<attributename>,<dataflag>,<value>,  
<worst>,<threshold>,<type>,<update>,  
<whenfailed>,<rawvalue>

**Example:** //Return storage information  
 DIAG:HUMS:STOR?  
**Returns for example:**  
 #44620[{"name":"/dev/sda","temperature":  
 305,"type":"ata","modelFamily":null,"model":  
 "SanDisk SD9SB8W128G","serialNumber":  
 "000000000000","id":  
 "5 001b44 8b67d0a7d","firmwareVersion":  
 "A1234000","userCapacity":  
 128035676160,"sectorSizeLogical":  
 512,"sectorSizePhysical":512,"rotationRate":  
 "0","formFactor":"2.5 inches","ataVersion":  
 "ACS-4 T13/BSR INCITS 529 revision 5","sataVersion":  
 "SATA 3.3","smartDataTable":[{"id":  
 5,"attributeName":  
 "Reallocated\_Sector\_Ct","dataFlag":50,"value":  
 100,"worst":100,"threshold":0,"type":  
 "Old\_age","updated":  
 "Always","whenFailed":null,"rawValue":0},{  
 "id":  
 9,"attributeName":"Power\_On\_Hours","dataFlag":  
 50,"value":100,"worst":100,"threshold":  
 0,"type":"Old\_age","updated":  
 "Always","whenFailed":null,"rawValue":16856}]

**Usage:** Query only

---

#### DIAGnostic:HUMS:SW?

This command returns the installed software information of the instrument. Depending on the set data format, the queried data is either displayed in XML or JSON format. For more information about setting the data format, see [DIAGnostic:HUMS:FORMat](#) on page 1075.

#### Return values:

<SoftwareInfo> <block\_data>

For each installed software package it returns the following information as block data in a comma-separated list:

```
#blockdata[{<index>,<name>,<softwareType>,<installDate>}]
```

Binary block data with the following syntax:

```
#<Digits><Length><Binarydata>
```

**#**  
 Indicates the start of the binary block

**<Digits>**  
 Decimal value  
 Gives the number of decimal digits used for the <Length> value

**<Length>**  
 Decimal value  
 Number of bytes the follow in the <Binary data> part

**<Binary data>**

Binary data in ASCII format

**Example:** //Return installed software information  
DIAG:HUMS:SW?

**Usage:** Query only

**DIAGnostic:HUMS:SYSTEM:INFO?**

This command returns the system information of the instrument. Depending on the set data format, the queried data is either displayed in XML or JSON format. For more information about setting the data format, see [DIAGnostic:HUMS:FORMat](#) on page 1075.

**Return values:**

**<SystemInfo>**            **<block\_data>**  
Returns system information of the connected instrument as block data.  
Binary block data with the following syntax:  
#<Digits><Length><Binarydata>  
**#**  
Indicates the start of the binary block  
**<Digits>**  
Decimal value  
Gives the number of decimal digits used for the <Length> value  
**<Length>**  
Decimal value  
Number of bytes the follow in the <Binary data> part  
**<Binary data>**  
Binary data in ASCII format

**Example:** //Return system information  
DIAG:HUMS:SYST:INFO?

**Usage:** Query only

**DIAGnostic:HUMS:SYSTEM:STATUS?**

This command returns the complete system status information of the instrument. Depending on the set data format, the queried data is either displayed in XML or JSON format. For more information about setting the data format, see [DIAGnostic:HUMS:FORMat](#) on page 1075.

**Return values:**

**<SystemStatus>**            **<block\_data>**  
Returns complete system status information of the connected instrument as block data in a comma-separated list:  
#blockdata{<globalStatus>,<tablevalues>:  
[ {tablevalue1}, {tablevalue2}, ... ] }

Binary block data with the following syntax:

```
#<Digits><Length><Binarydata>
```

**#**

Indicates the start of the binary block

**<Digits>**

Decimal value

Gives the number of decimal digits used for the <Length> value

**<Length>**

Decimal value

Number of bytes the follow in the <Binary data> part

**<Binary data>**

Binary data in ASCII format

For each table value it returns the following values:

```
<id>,<description>,<descriptionExtended>,<value>,<unit>,<upperLimit>,<lowerLimit>,<reference>,<severity>
```

**Example:**

```
//Return system status information
DIAG:HUMS:SYST:STAT?
#41874{"globalStatus":3,"values":[{"id":31522816,"description":
"RF Overload","descriptionExtended":
null,"value":null,"unit":null,"upperLimit":
null,"lowerLimit":null,"reference":
null,"severity":1},...]}
```

**Usage:**

Query only

### DIAGnostic:HUMS:SYSTEM:STATus:SUMMery?

This command returns the status summary of the complete system.

**Return values:**

<StatusSummary>

**OK**

The system is OK.

**WARNing**

There are some issues with the system which might be critical later.

**ERRor**

Problems with the system occurred and the status is critical.

**Example:**

```
//Return status summary of the system
DIAG:HUMS:SYST:STAT:SUMM?
```

**Usage:**

Query only

### 8.4.3 Device tags commands

|                                                       |      |
|-------------------------------------------------------|------|
| <a href="#">DIAGnostic:HUMS:TAGS:ALL?</a> .....       | 1081 |
| <a href="#">DIAGnostic:HUMS:TAGS[:VALue]</a> .....    | 1081 |
| <a href="#">DIAGnostic:HUMS:TAGS:DELeTe</a> .....     | 1082 |
| <a href="#">DIAGnostic:HUMS:TAGS:DELeTe:ALL</a> ..... | 1082 |

---

#### DIAGnostic:HUMS:TAGS:ALL?

This command returns all key-value tags that you have assigned to the instrument. Depending on the set data format, the queried data is either displayed in XML or JSON format. For more information about setting the data format, see [DIAGnostic:HUMS:FORMat](#) on page 1075.

#### Return values:

|         |                                                |
|---------|------------------------------------------------|
| <ID>    | ID number of the defined tag.                  |
| <Key>   | String containing key name of the defined tag. |
| <Value> | String containing value of the defined tag.    |

**Example:**           //Return all tags  
 DIAG:HUMS:TAGS:ALL?  
 1,"location","building\_11",2,"time zone","CET"

**Usage:**             Query only

**Manual operation:** See ["Add / Delete \(Trash\) / Delete All"](#) on page 532

---

**DIAGnostic:HUMS:TAGS[:VALue] <ID>, <Key>, <Value>**

**DIAGnostic:HUMS:TAGS[:VALue]? <ID>**

This command adds or modifies a key-value pair (device tag).

The query returns the key-value pair for a given ID or an empty string if the ID is unknown.

#### Parameters:

|         |                                                |
|---------|------------------------------------------------|
| <Key>   | String containing key name of the queried tag. |
| <Value> | String containing value of the queried tag.    |

#### Parameters for setting and query:

|      |                                                                                                                                                                                                                                |
|------|--------------------------------------------------------------------------------------------------------------------------------------------------------------------------------------------------------------------------------|
| <ID> | 0 - 31<br>ID number of the tag you want to modify or query.<br>To identify the ID number, query all device tags from the system first. For more information, read here <a href="#">DIAGnostic:HUMS:TAGS:ALL?</a> on page 1081. |
|------|--------------------------------------------------------------------------------------------------------------------------------------------------------------------------------------------------------------------------------|

**Example:**           //Add or modify a tag (tag 1)  
 DIAG:HUMS:TAGS 1,'location','building\_11'

**Manual operation:** See ["Add / Delete \(Trash\) / Delete All"](#) on page 532

**DIAGnostic:HUMS:TAGS:DELeTe <ID>**

This command deletes a certain tag you assigned to your instrument, including its key and value.

**Setting parameters:**

<ID> ID number of the tag you want to delete.  
To identify the ID number, query all device tags from the system first. For more information, see [DIAGnostic:HUMS:TAGS:ALL?](#) on page 1081.

**Example:** //Delete tag  
DIAG:HUMS:TAGS:DEL 0

**Usage:** Setting only

**Manual operation:** See "[Add / Delete \(Trash\) / Delete All](#)" on page 532

**DIAGnostic:HUMS:TAGS:DELeTe:ALL**

This command deletes all key-value tags you have assigned to the instrument.

**Example:** //Delete all tags  
DIAG:HUMS:TAGS:DEL:ALL

**Usage:** Event

**Manual operation:** See "[Add / Delete \(Trash\) / Delete All](#)" on page 532

### 8.4.4 Utilization commands

Using these commands you can retrieve the utilization information provided by the R&S HUMS.

They all require software option R&S ZND-980.

|                                                                           |      |
|---------------------------------------------------------------------------|------|
| <a href="#">DIAGnostic:HUMS:UTILization?</a> .....                        | 1082 |
| <a href="#">DIAGnostic:HUMS:UTILization:ACTivity:TRACKing:STATe</a> ..... | 1083 |
| <a href="#">DIAGnostic:HUMS:UTILization:HISTory?</a> .....                | 1084 |
| <a href="#">DIAGnostic:HUMS:UTILization:HISTory:DELeTe:ALL</a> .....      | 1084 |

**DIAGnostic:HUMS:UTILization?**

This command returns the current utilization data of the instrument.

Depending on the set data format, the queried utilization data is either displayed in XML or JSON format. For more information about setting the data format, see [DIAGnostic:HUMS:FORMat](#) on page 1075.

**Return values:**

<UtilizationData> <block\_data>  
Returns the current utilization data of the connected instrument as block data.

```
#blockdata[{utilization1},{utilization2},...]
```

Binary block data with the following syntax:

```
#<Digits><Length><Binarydata>
```

**#**

Indicates the start of the binary block

**<Digits>**

Decimal value

Gives the number of decimal digits used for the <Length> value

**<Length>**

Decimal value

Number of bytes that follow in the <Binary data> part

**<Binary data>**

Binary data in ASCII format

For each utilization it returns the following values:

```
<id>,<scope>,<reference>,<unit>,<description>,<value>,<startvalue>,<state>
```

**Example:**

```
//Return utilization data
```

```
DIAG:HUMS:UTIL?
```

Returns for example:

```
#123456[{"id":31719936,"scope":
"DEVICE_SPECIFIC","reference":null,"name":
"Self alignments","unit":
"counter","description":
"Report number of self alignments","value":
0,"startupValue":
0,"activityTracking":true},...]
```

**Usage:**

Query only

**DIAGnostic:HUMS:UTILization:ACTivity:TRACking:STATe <ID>, <State>**

**DIAGnostic:HUMS:UTILization:ACTivity:TRACking:STATe? <ID>**

This command sets the activity tracking of utilizations.

**Parameters:**

<State> ON | OFF | 1 | 0

**ON | 1**

Tracking activity = on

**OFF | 0**

Tracking activity = off

**Parameters for setting and query:**

<ID>

ID number of the utilization activity.

To find out the ID of the utilization, you have to query the complete utilization data. For more information, see [DIAGnostic:HUMS:UTILization?](#) on page 1082.

**Example:**

```
//Set activity tracking state of ID 31719936
```

```
DIAG:HUMS:UTIL:ACT:TRAC:STAT 31719936, '1'
```

**DIAGnostic:HUMS:UTILization:HISTory?**

This command returns the utilization history of the instrument. Each utilization or activity is assigned a timestamp for when the utilization has been active. Together they form a pair of values.

Depending on the set data format, the queried data is either displayed in XML or JSON format. For more information about setting the data format, see [DIAGnostic:HUMS:FORMat](#) on page 1075.

Timestamps follow the Unix time format.

**Return values:**

**<HistoryResult>**      **<block\_data>**

Returns utilization history of the connected instrument as block data out of timestamps and activities in the following format:

```
#blockdata{"timestamps":
[<timestamp1>,<timestamp2>,...],"activity":
[<activity1>,<activity2>,...]}
```

Pair of values:  
<timestamp1> + <activity1>, <timestamp2> + <activity2>

Binary block data with the following syntax:  
#<Digits><Length><Binarydata>  
#

Indicates the start of the binary block

**<Digits>**  
Decimal value  
Gives the number of decimal digits used for the <Length> value

**<Length>**  
Decimal value  
Number of bytes the follow in the <Binary data> part

**<Binary data>**  
Binary data in ASCII format

**Example:**

```
//Return utilization history
DIAG:HUMS:UTIL:HIST?
Returns for example:
#3440{"timestamps":
[1612259226,1612345626,1612432026,1612518426],"activity":
[0,0,66000,81000]}
```

**Usage:**

Query only

**DIAGnostic:HUMS:UTILization:HISTory:DELeTE:ALL**

This command deletes the complete utilization history information from the instrument.

Alternatively, you can delete:

- device history only with DIAG:HUMS:DEV:HIST:DEL:ALL



- all data with DIAG:HUMS:DEL:ALL

**Example:** //Delete complete utilization history  
DIAG:HUMS:UTIL:HIST:DEL:ALL

**Usage:** Event

## 8.4.5 Service date commands

Using these commands you can get and set instrument service dates.

These dates are part of the R&S HUMS information, but do not require software option R&S ZND-980.

|                                                |      |
|------------------------------------------------|------|
| DIAGnostic:SERvice:CALibration:DATE.....       | 1085 |
| DIAGnostic:SERvice:CALibration:DUE:DATE.....   | 1085 |
| DIAGnostic:SERvice:CALibration:DUE:STATE?..... | 1086 |
| DIAGnostic:SERvice:CALibration:INTerval?.....  | 1086 |
| DIAGnostic:SERvice:DATE.....                   | 1086 |
| DIAGnostic:SERvice:STATE?.....                 | 1086 |

---

### DIAGnostic:SERvice:CALibration:DATE <CalibrationDate>

This command sets last date and time the instrument was calibrated in ISO 8601 format.

**Parameters:**

<CalibrationDate> String containing calibration date of the instrument.

**Example:** //Set calibration date  
DIAG:SERV:CAL:DATE "2019-05-05T00:00:00Z"

**Manual operation:** See "[Last Calibration](#)" on page 537

---

### DIAGnostic:SERvice:CALibration:DUE:DATE <DueDate>

This command sets next date and time the instrument needs calibration to be done in ISO 8601 format. The response may be empty in case of no fixed next calibration due.

**Parameters:**

<DueDate> String containing next calibration due date.  
An empty string resets the date (= no due date).

**Example:** //Set calibration due date  
DIAG:SERV:CAL:DUE:DATE "2020-05-12T00:00:00Z"

**Manual operation:** See "[Next Calibration Due](#)" on page 537

**DIAGnostic:SERVice:CALibration:DUE:STATe?**

This command returns the state if the calibration is OK or the instrument requires calibration.

**Return values:**

|         |                                                                            |
|---------|----------------------------------------------------------------------------|
| <State> | <b>NAN</b><br>Not a number, e.g. if no due date is set.                    |
|         | <b>OK</b><br>Calibration is OK since due date has not expired yet.         |
|         | <b>EXPIred</b><br>Calibration due date has expired. Calibration is needed. |

**Example:**           //Return calibration due state  
DIAG:SERV:CAL:DUE:STAT?

**Usage:**            Query only

**DIAGnostic:SERVice:CALibration:INTerval? <Duration>**

Queries the recommended calibration interval, set by Rohde & Schwarz service.

**Parameters:**

<Duration>           String indicating the calibration interval ([ISO 8601 duration](#))

**Example:**           DIAG:SERV:CAL:INT?  
returns "P1Y" if the recommended calibration interval is 1 year

**Usage:**            Query only

**Manual operation:** See "[Recommended Calibration Interval](#)" on page 537

**DIAGnostic:SERVice:DATE <ServiceDate>**

This command sets the last date and time the instrument was serviced (ISO 8601 format).

**Parameters:**

<ServiceDate>       String containing last service date.

**Example:**           //Return last service date  
DIAG:SERV:DATE?

**Manual operation:** See "[Last Service](#)" on page 537

**DIAGnostic:SERVice:STATe?**

This command returns the state if the instrument requires service.

**Return values:**

|                |                                                             |
|----------------|-------------------------------------------------------------|
| <ServiceState> | <b>NAN</b><br>Not a number, e.g. if no service date is set. |
|----------------|-------------------------------------------------------------|

**OK**

Instrument is OK. No service is needed.

**DEVIations**

Deviations have been detected. Service might be required soon.

**REQUIred**

Instrument requires service.

**Example:** //Return service state  
DIAG:SERV:STAT?

**Usage:** Query only

## 8.5 R&S ZVR/ZVABT Compatible Commands

The commands in this chapter are supported for compatibility with analyzers of the R&S ZVR and R&S ZVAB family; they do not introduce any new functionality. For new programs, it is recommended to use the commands in [Chapter 8.3, "SCPI Command Reference"](#), on page 597.

|                                                            |      |
|------------------------------------------------------------|------|
| CALCulate<Chn>:LIMit:CONTRol:DOMain.....                   | 1088 |
| CALCulate<Chn>:LIMit:RDOMain:COMPLex.....                  | 1088 |
| CALCulate<Chn>:LIMit:RDOMain:FORMat.....                   | 1089 |
| CALCulate<Chn>:LIMit:RDOMain:SPACing.....                  | 1089 |
| CALCulate<Chn>:LIMit:LOWer:STATe.....                      | 1090 |
| CALCulate<Chn>:LIMit:UPPer:STATe.....                      | 1090 |
| CALCulate<Chn>:PARAmeter:DEFine.....                       | 1090 |
| CALCulate<Chn>:MARKer<Mk>:FUNCTion:BWIDTh.....             | 1092 |
| CALCulate<Chn>:MARKer<Mk>:FUNCTion:DELTA:STATe.....        | 1092 |
| CALCulate<Chn>:MARKer<Mk>:FUNCTion:TARGeT.....             | 1092 |
| CALCulate<Chn>:MARKer<Mk>:FUNCTion[:SELect].....           | 1093 |
| CALCulate<Chn>:MARKer<Mk>:MAXimum.....                     | 1093 |
| CALCulate<Chn>:MARKer<Mk>:MINimum.....                     | 1093 |
| CALCulate<Chn>:MARKer<Mk>:SEARch:LEFT.....                 | 1094 |
| CALCulate<Chn>:MARKer<Mk>:SEARch:NEXT.....                 | 1094 |
| CALCulate<Chn>:MARKer<Mk>:SEARch:RIGHT.....                | 1094 |
| CALCulate<Chn>:MARKer<Mk>:SEARch[:IMMEdiate].....          | 1094 |
| CALCulate<Chn>:MATH[:EXPReSSion][:DEFine].....             | 1094 |
| DIAGnostic:SERVice:FUNCTion.....                           | 1095 |
| FORMat:DEXPort:SOURce.....                                 | 1095 |
| INSTrument[:SELect].....                                   | 1096 |
| OUTPut<Chn>:DPORT.....                                     | 1096 |
| [SENSe<Ch>:]CORRection:CKIT:<ConnType>:<StandardType>..... | 1097 |
| [SENSe:]CORRection:CKIT:INSTall.....                       | 1098 |
| [SENSe<Ch>:]CORRection:COLLect[:ACQuire].....              | 1098 |
| [SENSe<Ch>:]CORRection:COLLect:METHod.....                 | 1099 |
| [SENSe<Ch>:]CORRection:COLLect:SAVE:DEFault.....           | 1100 |
| [SENSe<Ch>:]CORRection:COLLect:SAVE[:DUMMy].....           | 1101 |
| [SENSe<Ch>:]CORRection:DATA.....                           | 1102 |
| [SENSe<Ch>:]CORRection:OFFSet<PhyPt>:MAGNitude.....        | 1104 |

|                                                           |      |
|-----------------------------------------------------------|------|
| [SENSe<Ch>:]FREQUency:MODE.....                           | 1104 |
| [SENSe<Ch>:]SEGMENT<Seg>:CLEar.....                       | 1105 |
| [SENSe<Ch>:]SEGMENT<Seg>:OVERlap.....                     | 1105 |
| [SENSe<Ch>:]SWEep:SPACing.....                            | 1105 |
| [SENSe<Chn>:]FUNctIon[:ON].....                           | 1106 |
| SOURce<Ch>:POWer<PhyPt>:CORRection:COLLect[:ACQuire]..... | 1107 |
| TRACe:CLEar.....                                          | 1108 |
| TRACe[:DATA][:RESPonse][:ALL]?                            | 1108 |
| TRACe[:DATA]:STIMulus[:ALL]?                              | 1109 |

---

### CALCulate<Chn>:LIMit:CONTRol:DOMain <SweepType>

Deletes the existing limit line and (re-)defines the physical units of the stimulus values of the limit line. The units of the response values and the scaling of the y-axis can be defined via `CALCulate<Ch>:LIMit:RDOMain:...`

#### Suffix:

<Chn> Channel number used to identify the active trace.

#### Setting parameters:

<SweepType> FLIN | FLOG | FSEG | FSINgle | TLIN | TLOG | PLIN | PLOG | PSINgle

Keywords for the units of the stimulus values. The selected unit must be compatible with the sweep type (`[SENSe<Ch>:]SWEep:TYPE`); otherwise the limit line can not be displayed and no limit check is possible.

The parameters form three groups: FLIN, FLOG, FSEG, and FSINgle select frequency units for the limit line. TLIN and TLOG select time units, PLIN, PLOG and PSINgle select power units.

\*RST: FLIN

Default unit: Hz (for FLIN, FLOG, FSEG, FSINgle); s (for TLIN, TLOG), dBm (for PLIN, PLOG, PSINgle).

#### Example:

```
SWE:TYPE POW
```

Select a power sweep.

```
CALC:LIM:CONT:DOM PLIN
```

Delete all existing limit line segments and select level units for the limit line of the active trace.

```
CALC:LIM:CONT -20, -10
```

Define a limit line segment in the stimulus range between -20 dBm and -10 dBm.

#### Usage:

Setting only

---

### CALCulate<Chn>:LIMit:RDOMain:COMPLex <UnitRef>

Deletes the existing limit line and (re-)defines the physical units of the response values of the limit line. The units of the stimulus values are defined via `CALCulate<Chn>:LIMit:CONTRol:DOMain`.

**Tip:** This command is complemented by `CALCulate<Chn>:LIMit:RDOMain:FORMat` and `CALCulate<Chn>:LIMit:RDOMain:SPACing`.

**Suffix:**

<Chn> Channel number used to identify the active trace.

**Setting parameters:**

<UnitRef> S | SINV | Y | Z | YREL | ZREL  
 Keyword for the physical unit of the response values. The parameters form four groups: S and SINV select relative units (dB) for the limit line. Y selects admittance units (S/Siemens). Z selects impedance units ( $\Omega$ ). YREL and ZREL select dimensionless numbers (U).

**Usage:** Setting only

**CALCulate<Chn>:LIMit:RDOMain:FORMat <UnitRef>**

Deletes the existing limit line and (re-)defines the physical units of the response values of the limit line. The units of the stimulus values are defined via `CALCulate<Chn>:LIMit:CONTrol:DOMain`.

**Tip:** This command is complemented by `CALCulate<Chn>:LIMit:RDOMain:COMPLex` and `CALCulate<Chn>:LIMit:RDOMain:SPACing`.

**Suffix:**

<Chn> Channel number used to identify the active trace.

**Setting parameters:**

<UnitRef> COMPLex | MAGNitude | PHASe | REAL | IMAGinary | SWR | GDELay | L | C  
 Keyword for the physical unit of the response values. The parameters form four groups: COMPLex, REAL, IMAGinary, and SWR select dimensionless numbers (U) for the limit line. MAGNitude selects relative units (dB). PHASe selects phase units (deg). GDELay selects time units (s). L selects inductance units (H/Henry). C selects capacitance units (F/Farad).

**Usage:** Setting only

**CALCulate<Chn>:LIMit:RDOMain:SPACing <Format>**

Deletes the existing limit line and (re-)defines the physical units of the response values of the limit line. The units of the stimulus values are defined via `CALCulate<Chn>:LIMit:CONTrol:DOMain`.

**Tip:** This command is complemented by `CALCulate<Chn>:LIMit:RDOMain:COMPLex` and `CALCulate<Chn>:LIMit:RDOMain:FORMat`.

**Suffix:**

<Chn> Channel number used to identify the active trace.

**Setting parameters:**

<Format> LINear | LOGarithmic | DB | SIC  
 Keyword for the physical unit of the response values.  
 Default unit: dB (irrespective of the parameter selected)

**Usage:** Setting only

**CALCulate<Chn>:LIMit:LOWer:STATe** <Boolean>

**CALCulate<Chn>:LIMit:UPPer:STATe** <Boolean>

These commands switch the lower and upper limit check on or off. Lower limit line segments are assigned even numbers; upper limit line segments are assigned odd numbers; see `CALCulate<Chn>:LIMit:LOWer[:DATA]` and `CALCulate<Chn>:LIMit:UPPer[:DATA]`. `CALCulate<Chn>:LIMit:LOWer:STATe` does not affect segments with odd numbers; `CALCulate<Chn>:LIMit:UPPer:STATe` does not affect segments with even numbers.

**Note:** Use `CALCulate<Chn>:LIMit:STATe` to switch on or off the entire limit check, including upper and lower limit lines.

**Suffix:**

<Chn> Channel number used to identify the active trace.

**Parameters:**

<Boolean> ON | OFF - switch limit check on or off.

\*RST: OFF

**Example:**

```
CALC:LIM:LOW -10, 0, 0, -10
```

Define two limit line segments covering the entire sweep range. Two upper limit line segments with default response values are created in addition.

```
CALC:LIM:UPP 0, 5, 5, 0
```

Change the response values of the upper limit line segments.

```
CALC:LIM:LOW:STAT ON; :CALC:LIM:UPP:STAT ON; :
```

```
CALC:LIM:FAIL?
```

Switch the limit check on and query the result.

**Manual operation:** See "Limit Check" on page 306

**CALCulate<Ch>:PARAmeter:DEFine** <TraceName>, <Result>[, <TestPortNum>]

Creates a trace and assigns a channel number, a name and a measurement parameter to it. The trace is not displayed. To display a trace defined via

`CALCulate<Ch>:PARAmeter:DEFine`, a window must be created (`DISPlay[:WINDow<Wnd>][:STATe] ON`) and the trace must be assigned to this window (`DISPlay[:WINDow<Wnd>]:TRACe<WndTr>:FEED`); see example below.

Traces must be selected to become active traces; see `CALCulate<Ch>:PARAmeter:SElect`.

**Note:** The parameter names in this command differ from R&S ZND conventions; moreover the parameter list is not complete. The alternative command `CALCulate<Ch>:PARAmeter:SDEFine` uses a complete parameter list with compatible names.

**Suffix:**

<Ch> Channel number. <Ch> may be used to reference a previously defined channel. If <Ch> does not exist, it is generated with default channel settings.

**Setting parameters:**

<TraceName> Trace name, e.g. 'Trc4'. See "Rules for trace names" in "Table Area" on page 268.

<Result> S11 | S12 | S13 | S14 | S21 | S22 | S23 | S24 | S31 | S32 | S33 | S34 | S41 | S42 | S43 | S44 | A | B | C | D | R1 | R2 | R3 | R4 | AB | AC | AD | BA | BC | BD | CA | CB | CD | DA | DB | DC | AR1 | AR2 | AR3 | AR4 | BR1 | BR2 | BR3 | BR4 | CR1 | CR2 | CR3 | CR4 | DR1 | DR2 | DR3 | DR4 | R1A | R1B | R1C | R1D | R2A | R2B | R2C | R2D | R3A | R3B | R3C | R3D | R4A | R4B | R4C | R4D | R1R2 | R1R3 | R1R4 | R2R1 | R2R3 | R2R4 | R3R1 | R3R2 | R3R4 | R4R1 | R4R2 | R4R3  
Measurement parameter; see list of parameters below.

<TestPortNum> Test port number, drive port for wave quantities and ratios, ignored for S-parameters.

**Example:**

```
CALC4:PAR:DEF 'Ch4Tr1', S11
```

Create channel 4 and a trace named Ch4Tr1 to measure the input reflection coefficient S11.

```
DISP:WIND:STAT ON
```

Create diagram area no. 1.

```
DISP:WIND:TRAC2:FEED 'CH4TR1'
```

Display the generated trace in diagram area no. 1, assigning a trace number 2.

**Usage:** Setting only

The measurement parameter is selected by means of the following keywords (the selection depends on the number of test ports of the analyzer, e.g. S44 is not available on 2-port analyzers):

|                                                                                               |                                                                                   |
|-----------------------------------------------------------------------------------------------|-----------------------------------------------------------------------------------|
| S11   S12   S13   S14   S21   S22   S23   S24   S31   S32   S33   S34   S41   S42   S43   S44 | S-parameters                                                                      |
| A   B   C   D                                                                                 | Wave quantities $b_1, b_2, b_3, b_4$ (received waves)                             |
| R1   R2   R3   R4                                                                             | Wave quantities $a_1, a_2, a_3, a_4$ (reference waves)                            |
| AB   AC   AD   BA   BC   BD   CA   CB   CD   DA   dB   DC                                     | Ratio of wave quantities $b_1/b_2, b_1/b_3, \dots, b_4/b_3$ (received waves only) |

|                                                                                                                                                                                                        |                                                                                                                                                                        |
|--------------------------------------------------------------------------------------------------------------------------------------------------------------------------------------------------------|------------------------------------------------------------------------------------------------------------------------------------------------------------------------|
| AR1   AR2   AR3   AR4   BR1   BR2   BR3   BR4  <br>CR1   CR2   CR3   CR4   DR1   DR2   DR3   DR4  <br>R1A   R1B   R1C   R1D   R2A   R2B   R2C   R2D  <br>R3A   R3B   R3C   R3D   R4A   R4B   R4C   R4D | Ratio of wave quantities $b_1/a_1, b_1/a_2, \dots, b_4/a_4, a_1/b_1, a_1/b_2, \dots, A_4/B_4$ (received waves to reference waves or reference waves to received waves) |
| R1R2   R1R3   R1R4   R2R1   R2R3   R2R4   R3R1  <br>R3R2   R3R4   R4R1   R4R2   R4R3                                                                                                                   | Ratio of wave quantities $a_1/a_2, a_1/a_3, \dots, a_4/a_3$ (reference waves only)                                                                                     |

---

**CALCulate<Chn>:MARKer<Mk>:FUNctioN:BWIDth** <Bandwidth>

Defines the bandfilter level, i.e. the minimum excursion for the bandpass and bandstop peaks.

**Tip:** Use `CALCulate<Chn>:MARKer<Mk>:BWIDth` to set the bandwidth and query the results of a bandfilter search. Note the sign convention for input values.

**Suffix:**

<Chn> Channel number used to identify the active trace.

<Mk> This numeric suffix is ignored and may be set to any value because the bandfilter search functions always use markers M1 to M4.

**Parameters:**

<Bandwidth> Range: -100 dB to 100 dB  
Increment: 0.03 dB  
\*RST: 3 dB  
Default unit: dB

**Example:** See `CALCulate<Chn>:MARKer<Mk>:BWIDth`

---

**CALCulate<Chn>:MARKer<Mk>:FUNctioN:DELTA:STATe** <Boolean>

Switches the delta mode for marker <Mk> on trace no. <Chn> on or off.

**Note:** This command is the ZVR-compatible equivalent of `CALCulate<Chn>:MARKer<Mk>:DELTA[:STATe]`.

**Suffix:**

<Chn> Channel number used to identify the active trace.

<Mk> Marker number.

**Parameters:**

<Boolean> ON | OFF - enable or disable the delta mode.  
\*RST: OFF

---

**CALCulate<Chn>:MARKer<Mk>:FUNctioN:TARGeT** <SearchValue>

Defines the target value for the target search of marker no. <Mk>, which can be activated using `CALCulate<Chn>:MARKer<Mk>:FUNctioN:EXECute TARGeT`.

**Note:** This command is the ZVR-compatible equivalent of `CALCulate<Chn>:MARKer<Mk>:TARGeT`.



**Suffix:**

<Chn> Channel number used to identify the active trace.

<Mk> Marker number.

**Parameters:**

<SearchValue> Target search value of marker no. <Mk>.

Range: Depending on the format of the active trace. For a dB Mag trace the range is -200 dB to +200 dB.

Increment: 0.1 dB

\*RST: Depending on the trace format; 0 dB for a dB Mag trace.

Default unit: dB

**CALCulate<Chn>:MARKer<Mk>:FUNction[:SElect] <Mode>**

Selects a search mode for marker no. <Mk>, which can then be initiated using one of the `CALCulate<Ch>:MARKer<Mk>:SEARch...`,

`CALCulate<Ch>:MARKer<Mk>:MAXimum` or

`CALCulate<Ch>:MARKer<Mk>:MINimum` functions. The marker must be created before using `CALCulate<Chn>:MARKer<Mk>[:STATe] ON`.

**Note:** This command is not needed except for compatibility with ZVR programs. Use `CALCulate<Chn>:MARKer<Mk>:FUNction:EXECute` to select a search mode and at the same time initiate the search. The

`CALCulate<Ch>:MARKer<Mk>:SEARch...`,

`CALCulate<Ch>:MARKer<Mk>:MAXimum` or

`CALCulate<Ch>:MARKer<Mk>:MINimum` functions also select the search mode.

**Suffix:**

<Chn> Channel number used to identify the active trace.

<Mk> Marker number. For a bandfilter search (`BFILter`) this numeric suffix is ignored and may be set to any value because the bandfilter search functions always use markers M1 to M4.

**Parameters:**

<Mode> MAXimum | MINimum | RPEak | LPEak | NPEak | TARGet | LTARget | RTARget | BFILter | MMAXimum | MMINimum | SPRogress

See `CALCulate<Chn>:MARKer<Mk>:FUNction:EXECute`

**CALCulate<Chn>:MARKer<Mk>:MAXimum****CALCulate<Chn>:MARKer<Mk>:MINimum**

These commands select a search mode for marker no. <Mk> and initiate a maximum and minimum search, respectively. The marker must be created before using

`CALCulate<Chn>:MARKer<Mk>[:STATe] ON`.

**Note:** These commands are the ZVR-compatible equivalent of `CALCulate<Chn>:MARKer<Mk>:FUNction:EXECute` MINimum | MAXimum.

**Suffix:**  
 <Chn> Channel number used to identify the active trace.  
 <Mk> Marker number.  
**Usage:** Event

**CALCulate<Chn>:MARKer<Mk>:SEARch:LEFT**  
**CALCulate<Chn>:MARKer<Mk>:SEARch:NEXT**  
**CALCulate<Chn>:MARKer<Mk>:SEARch:RIGHT**

These commands selects a search mode for marker no. <Mk> and initiate a search for the next valid peak to the left, the next highest or lowest value among the valid peaks, and the next valid peak to the right. The marker must be created before using [CALCulate<Chn>:MARKer<Mk>\[:STATE\] ON](#).

**Note:** These commands are the ZVR-compatible equivalents of [CALCulate<Chn>:MARKer<Mk>:FUNCTION:EXECute LPEak | NPEak | RPEak](#).

**Suffix:**  
 <Chn> Channel number used to identify the active trace.  
 <Mk> Marker number.  
**Usage:** Event

**CALCulate<Chn>:MARKer<Mk>:SEARch[:IMMEDIATE]**

Initiates a search according to the search function selected with [CALCulate<Chn>:MARKer<Mk>:FUNCTION\[:SElect\]](#). The marker must be created before using [CALCulate<Chn>:MARKer<Mk>\[:STATE\] ON](#).

**Note:** Together with [CALCulate<Chn>:MARKer<Mk>:FUNCTION\[:SElect\]](#) this command is the ZVR-compatible equivalent of [CALCulate<Chn>:MARKer<Mk>:FUNCTION:EXECute](#).

**Suffix:**  
 <Chn> Channel number used to identify the active trace.  
 <Mk> Marker number. For a bandfilter search ([BFILter](#)) this numeric suffix is ignored and may be set to any value because the bandfilter search functions always use markers M1 to M4.  
**Usage:** Event

**CALCulate<Chn>:MATH[:EXPRession][:DEFine] <Expression>**

Defines a simple mathematical relation between traces. To calculate and display the new mathematical trace, the mathematical mode must be switched on ([CALCulate<Chn>:MARKer<Mk>\[:STATE\] ON](#)).

**Note:** This command places some restrictions on the mathematical expression and the operands. Use `CALCulate<Chn>:MATH[:EXPRession]:SDEFine` to define general expressions.

**Suffix:**

<Chn> Channel number used to identify the active trace.

**Parameters:**

<Expression> <expr>  
 (<operand1><operator1><operand2>[<operator2><operand3>]) The expression must be enclosed in brackets.  
 Operands: See list of trace names in [Chapter 8.3.18, "TRACe Commands"](#), on page 1057.  
 Operators: +, -, \*, /

**Example:**

```
*RST; CALC:MATH:MEM
```

Copy the current state of the default trace Trc1 to a memory trace named "Mem2[Trc1]". The memory trace is not displayed.

```
CALC:MATH (CH1DATA / MDATA2)
```

Define a mathematical trace, dividing the data trace by the stored memory trace. The mathematical trace is not displayed

```
CALC:MATH:STAT ON
```

Display the mathematical trace instead of the active data trace.

**DIAGnostic:SERvice:FUNction** <SFId1>, <SFId2>...

Activates a service function (mainly for internal use). Service functions are identified by groups of numbers, separated by dots.

**Parameters:**

<SFId1>

<SFId2> Service function identifier entered as a (pseudo-)numeric value, the dots being replaced by commas. Five groups of numbers are allowed at maximum. See also [DIAGnostic:SERvice:SFUNction](#).

**FORMat:DEXPort:SOURce** <Format>

Defines the format for traces retrieved with the R&S ZVR-compatible command `TRACe[:DATA][:RESPonse][:ALL]?`.

This command is not relevant for results read with the `CALCulate<Chn>:DATA...` commands.

**Parameters:**

&lt;Format&gt;

FDATa | SDATa | MDATa

See list of parameters below. The unit is the default unit of the measured parameter; see [CALCulate<Ch>:PARAMeter:SDEFine](#).

Range: Depending on the measured parameter and format.

\*RST: SDATa

**Example:**

See [TRACe\[:DATA\]\[:RESPonse\]\[:ALL\]?](#)

The following parameters are related to trace data:

|       |                                                                                                                                                                                                 |
|-------|-------------------------------------------------------------------------------------------------------------------------------------------------------------------------------------------------|
| FDATa | Formatted trace data, according to the selected trace format ( <a href="#">CALCulate&lt;Chn&gt;:FORMAT</a> ). 1 value per trace point for Cartesian diagrams, 2 values for polar diagrams.      |
| SDATa | Unformatted trace data: Real and imaginary part of each measurement point. 2 values per trace point irrespective of the selected trace format. The trace mathematics is not taken into account. |
| MDATa | Unformatted trace data (see <a href="#">SDATa</a> ) after evaluation of the trace mathematics.                                                                                                  |

**INSTrument[:SElect] <Channel>**

Selects a channel <Ch> as active channel. To select a channel number > 4 use the generalized command [INSTrument:NSElect](#).

**Parameters:**

&lt;Channel&gt;

CHANnel1 | CHANnel2 | CHANnel3 | CHANnel4

Number of the channel to be activated. The channel must be created before using [CONFigure:CHANnel<Ch>\[:STATe\]](#) ON.

\*RST: CHANNEL1

**Example:**

```
CONF:CHAN2:STAT ON; :INST CHANnel2
```

Create channel no. 2 and select it as the active channel.

**OUTPut<Chn>:DPORt <Port>**

Selects a source port for the stimulus signal (drive port). The setting acts on the active trace. The effect of the drive port selection depends on the measurement parameter associated to the active trace:

- If an S-parameter  $S_{\text{out}<in>}$  is measured, the second port number index <in> (input port of the DUT = drive port of the analyzer) is set equal to the selected drive port: Drive port selection affects the measured quantity.
- If a wave quantity or a ratio is measured, the drive port is independent from the measured quantity:

**Note:** This command is equivalent to [\[SENSe<Chn>:\]SWEep:SRCPort](#).

**Suffix:**

&lt;Chn&gt;

Channel number used to identify the active trace

**Parameters:**

<Port> PORT<no>  
Physical port number.  
\*RST: PORT1

**Example:**

```
CALC4:PAR:SDEF 'Ch4Tr1', 'A1'
```

Create channel 4 and a trace named "Ch4Tr1" to measure the wave quantity  $a_1$ . The trace automatically becomes the active trace.

```
OUTP4:DPOR PORT2
```

Select drive port 2 for the active trace.

---

**[SENSe<Ch>:]CORRection:CKIT:<ConnType>:<StandardType>** <CalkitName>, <Standard>, <MinFreq>, <MaxFreq>, <DelayParam>, <Loss>, <C0>, <L0>, <C1>, <L1>, <C2>, <L2>, <C3>, <L3>, OPEN | SHORT

Defines the parameters of a calibration standard <StandardType> for a specified connector type <ConnType>. A particular physical standard can be selected by specifying the name of the calibration kit and its serial number. Depending on the standard type, only a subset of the parameters may be used; see [Standard types and their parameters](#).

**Note:** If the specified cal kit does not exist, it is created with the specified calibration standard.

**Suffix:**

<Ch> Channel number. This suffix is ignored because calibration kits are channel-independent.

**Parameters:**

<ConnType> Connector type, one of the following identifiers:  
N50, N75: N 50  $\Omega$  or N 75  $\Omega$  connectors  
PC7, PC35, PC292: PC 7, PC 3.5 or 2.92 mm connectors  
USER<no>: User-defined connectors UserConn1, UserConn2  
SMA: User-defined connector type SMA ...  
**Note:** This command only supports ZVR-compatible connector types. For general definitions use [\[SENSe:\]CORRection:CKIT:<StandardType>](#).

<StandardType> Standard type. For reflection standards, the first character denotes the gender, e.g.:  
FOPEN, MOOPEN: Open (f) or Open (m) standard.  
For transmission standards, the first two characters denotes the genders on both ends, e.g.:  
FFSNetwork, MFSNetwork, MMSNetwork: Symm. network (ff), symm. network (mf) or symm. network (mm) standard.  
For a complete list of standard types refer to [Standard types and their parameters](#).

**Parameter list** String parameters to specify the configured standard (<CalkitName>, <StandardLabel>) and numeric parameters defining its properties. See [Parameter list](#).

\*RST: n/a

**Example:**

```
CORR:CKIT:N50:FOPEN 'ZV-Z21', '',
0,1.8E+010,0.0151,0,0,0.22,-0.22,0.0022
```

Define the properties of the open (f) standard for the N 50 Ω connector type contained in the ZV-Z21 calibration kit: Assign a valid frequency range of 0 Hz to 18 GHz, an electrical length of 15.1 mm, 0 dB loss and define the polynomial coefficients of the fringing capacitance as 0 fF, 0.22 fF/GHz, -0.22 fF/(GHz)<sup>2</sup>, 0.0022 fF/(GHz)<sup>3</sup>.

**[SENSe:]CORRection:CKIT:INSTall <CalKitFile>**

Loads cal kit data from a specified R&S ZVR cal kit file.

**Setting parameters:**

<CalKitFile> String parameter to specify the name and directory of the cal kit file to be loaded.

**Note:** The loaded file must be a R&S ZVR-specific cal kit file with the extension \*.ck. VNA cal kit files (\*.calkit) can be imported using the [MMEMoRY:LOAD:CKIT](#) command. Keysight cal kit files can be imported manually and converted into \*.calkit files.

**Example:**

```
CORR:CKIT:INST 'C:\Users\Public\Documents
\Rohde-Schwarz\Vna\Calibration\Kits\ZCAN.ck'
```

Load the previously created R&S ZVR cal kit file ZCAN.ck from the default cal kit directory.

```
MMEM:STOR:CKIT 'ZCAN', 'C:
\Users\Public\Documents
\Rohde-Schwarz\Vna\Calibration\Kits\ZCAN.calkit'
```

Store the imported cal kit data to a VNA cal kit file ZCAN.calkit (assuming that the cal kit name stored in ZCAN.ck reads "ZCAN").

**Usage:** Setting only

**[SENSe<Ch>:]CORRection:COLLect[:ACQuire] <Standard>[, <Dispersion>[, <Delay>]]**

Starts a calibration measurement in order to acquire measurement data for the selected standards. The standards are reflection or transmission standards and must be connected to port 1 or 2 of the analyzer.

**Tip:** Use the generalized command [\[SENSe<Ch>:\]CORRection:COLLect\[:ACQuire\]:SELected](#) to obtain measurement data at arbitrary analyzer ports.

**Suffix:**

<Ch> Channel number of the calibrated channel.

**Setting parameters:**

<Standard>

THRough | OPEN1 | OPEN2 | OPEN12 | SHORt1 | SHORt2 | SHORt12 | MATCh1 | MATCh2 | MATCh12 | NET | ATT | IMATCh12 | REFL1 | REFL2 | SLIDe1 | SLIDe2 | SLIDe12 | LINe1 | LINe2 | LINe3 | M1O2 | O1M2 | OSHort1 | OSHort11 | OSHort12 | OSHort13 | OSHort2 | OSHort21 | OSHort22 | OSHort23 | M1S2 | S1M2 | UTHRough

Standard types: Through (between port 1 and 2), Open, Short, Match (MATCh12 and IMATCh12 are synonymous), Symmetric Network (NET), Attenuation (ATT), Reflect, Sliding Match (SLIDe), Line1 (LINe1 and LINE are synonymous), Line2 and Line3 (esp. for TRL calibration), Match/Open (M1O2, O1M2), Match/Short (M1S2, S1M2), Offset Short (OSHort), Unknown Through (UTHRough).

The numbers in the parameter names denote the analyzer ports. Two numbers 12 mean that two separate calibrations are performed at ports 1 and 2. For Offset Short standards, the first number denotes the port (1 or 2), the second number denotes the number of the standard (1 to 3).

\*RST: ON

<Dispersion>

Optional status parameter for UTHRough standard:  
OFF - unknown through standard is non-dispersive.  
ON - unknown through standard is dispersive.

\*RST: OFF

<Delay>

Optional entry of delay time or phase for UTHRough standard:  
<numeric> - entry of the delay time in ps (for non-dispersive standards) or of an estimate of the phase at the start frequency of the sweep in deg (for dispersive standards). See also background information for [\[SENSe<Ch>:\]CORRection:COLLect\[:ACQuire\]:SELected](#).

AUTO - the analyzer determines the delay time or phase during the calibration sweep.

\*RST: AUTO

**Example:**

See [\[SENSe<Ch>:\]CORRection:COLLect:SAVE\[:DUMMy\]](#)

**Usage:**

Setting only

---

**[SENSe<Ch>:]CORRection:COLLect:METHod <CalType>**

Selects a one-port or two-port calibration type for channel <Ch> at ports 1/2.

**Tip:** Use the generalized command [\[SENSe<Ch>:\]CORRection:COLLect:METHod:DEFine](#) to select the calibration type for arbitrary analyzer ports or a multiport calibration type.

**Suffix:**

<Ch> Channel number of the calibrated channel.

**Parameters:**

<CalType> FRTRans | PFRTrans | FTRans | PFTRans | RTRans | PRTRans | TOM | TSM | TRM | TRL | TNA | TOSM | ETOM | ETSM | FOPort1 | FOPort2 | FOPort12 | FOPTport | ROPTport | REFL1 | REFL2 | REFL12 | TPORT | UOSM

Calibration types, TOM, TRM, TRL, TNA, TOSM, Full One Port, One Path Two Port, Normalization (REFL1, REFL2 and REFL12 for one-port, FRTRans, FTRans, RTRans, and TPORT for two-port), TOSM with unknown through.

The numbers in the parameters denote the analyzer ports.

Parameters for two-port calibration types contain no numbers because the command is only valid for ports 1 and 2.

**Example:**

See `[SENSe<Ch>:]CORRection:COLLect:SAVE[:DUMMy]`

**[SENSe<Ch>:]CORRection:COLLect:SAVE:DEFAult**

Generates a set of default system error correction data for the selected ports and calibration type. The default data set corresponds to a test setup which does not introduce any systematic errors; none of the measurement results acquired previously (`[SENSe<Ch>:]CORRection:COLLect[:ACQuire]`) is taken into account.

**Tip:** The main purpose of the default correction data set is to provide a dummy system error correction which you can replace with your own, external correction data. You may have acquired the external data in a previous session or even on an other instrument. If you want to use the external correction data on the analyzer, simply generate the default data set corresponding to your port configuration and calibration type and overwrite the default data. For details refer to the program example below.

**Note:** This command must be used in combination with the R&S ZVR-compatible commands `[SENSe<Ch>:]CORRection:COLLect:METhod` and `[SENSe<Ch>:]CORRection:DATA`. Use `[SENSe<Ch>:]CORRection:COLLect:SAVE:SELected:DEFAult` if you want to use R&S ZND-specific calibration commands or if you want to calibrate more than 2 ports.

**Suffix:**

<Ch> Channel number of the calibrated channel



**Example:**

```
CORR:COLL:METH REFL1
```

Select a one-port normalization at port 1 with an open standard as calibration type.

```
CORR:COLL:SAVE:DEF
```

Calculate a dummy system error correction for the normalization at port 1. The dummy system error correction provides the reflection tracking error term SCORR3.

```
INIT:CONT OFF; :INIT; *WAI
```

Stop the sweep to ensure correct transfer of calibration data.

```
CORR:DATA? 'SCORR3'
```

Query the dummy system error correction term. The response is a 1 (written as 1, 0 for the real and imaginary part) for each sweep point (no attenuation and no phase shift between the analyzer and the calibration plane).

```
CORR:DATA 'SCORR3', <ASCII_data>
```

Replace the dummy system error correction term with your own correction data, transferred in ASCII format.

```
INIT:CONT ON
```

Restart the sweep in continuous mode.

**Usage:**

Event

**[SENSe<Ch>:]CORRection:COLLect:SAVE[:DUMMY]**

Calculates the system error correction data from the acquired one or two-port measurement results ([\[SENSe<Ch>:\]CORRection:COLLect\[:ACQuire\]](#)), stores them and applies them to the calibrated channel <Ch>. To avoid incompatibilities, older system error correction data is deleted unless it has been transferred into a cal pool ([MMEMory:STORe:CORRection](#)).

This command is the R&S ZVR-compatible equivalent of [\[SENSe<Ch>:\]CORRection:COLLect:SAVE:SElected\[:DUMMY\]](#). It must be used in combination with the R&S ZVR-compatible commands for calibration method and standard selection; see example below.

**Suffix:**

<Ch>

Channel number of the calibrated channel.

**Example:**

```
CORR:COLL:METH REFL1
```

Select a one-port normalization at port 1 as calibration type.

```
CORR:COLL OPEN1
```

Measure an open standard connected to port 1 and store the measurement results of this standard.

```
CORR:COLL:SAVE
```

Calculate the system error correction data and apply it to the active channel.

**Usage:**

Event

**[SENSe<Ch>:]CORRection:DATA** <ErrorTerm>, <Parameter>...

Writes or reads system error correction data for a specific channel <Ch> and calibration method ([SENSe<Ch>:]CORRection:COLLect:MEthod). The analyzer test ports 1 or 2 are implicitly specified with the correction terms. The setting command can be used to transfer user-defined correction data to the analyzer; the query returns the current correction data set. ASCII or block data can be transferred, depending on the selected data transfer format (FORMat[:DATA])

The sweep must be stopped to transfer calibration data; see program example for [SENSe<Ch>:]CORRection:COLLect:SAVE:DEFault.

**Note:** This command affects the active calibration of channel no. <Ch> or the factory calibration (if no channel calibration is active). For the factory calibration, the query form is allowed only (no change of factory calibration data).

**Tip:** Use the generalized command [SENSe<Ch>:]CORRection:CDATa to transfer calibration data for arbitrary analyzer ports. The analyzer provides a default calibration corresponding to a test setup which does not introduce any systematic errors; see [SENSe<Ch>:]CORRection:COLLect:SAVE:DEFault.

### G and H matrices

The 7-term calibration types named Txx (e.g. TOM, TSM, TRM, TRL, TNA) are based on a network analyzer with two ports i and j, each equipped with a test receiver and a reference receiver. The system errors are described in terms of two "error two-ports" P<sub>G</sub> and P<sub>H</sub>:

- The error two-port P<sub>G</sub> is assigned to port i of the analyzer. Its transmission matrix G describes how the system errors modify the outgoing and incident waves at port i:

$$\begin{bmatrix} \mathbf{b}_i \\ \mathbf{a}_i \end{bmatrix} = \begin{bmatrix} \mathbf{G}_{11} & \mathbf{G}_{12} \\ \mathbf{G}_{21} & \mathbf{G}_{22} \end{bmatrix} * \begin{bmatrix} \mathbf{m}_{i\text{ref}} \\ \mathbf{m}_{i\text{test}} \end{bmatrix}$$

- The error two-port P<sub>H</sub> is assigned to port j of the analyzer. Its transmission matrix H describes how the system errors modify the measured incident and outgoing waves at port j:

$$\begin{bmatrix} \mathbf{a}_j \\ \mathbf{b}_j \end{bmatrix} = \begin{bmatrix} \mathbf{H}_{11} & \mathbf{H}_{12} \\ \mathbf{H}_{21} & \mathbf{H}_{22} \end{bmatrix} * \begin{bmatrix} \mathbf{m}_{j\text{test}} \\ \mathbf{m}_{j\text{ref}} \end{bmatrix}$$

In the two equations above, a and b denote the waves at the calibrated reference plane i and j (e.g. the input and output of the 2-port DUT). The m waves are the raw measured waves of test port i and j. The subscripts "ref" and "test" refer to the reference and test receivers, respectively. During the calibration the network analyzer acquires ratios of wave quantities, which leaves one of non-diagonal matrix elements of G or H as a free normalization factor. The network analyzer uses the normalization H<sub>21</sub> = 1.

#### Suffix:

<Ch> Channel number of the calibrated channel

#### Parameters:

<ErrorTerm>

String parameters describing the different error terms, depending on the current calibration method; see table below. Each term contains one complex value (real and imaginary part) for each sweep point. The parameters must be transferred in full length. The following strings are allowed:

'SCORR1' - directivity at port 1

'SCORR2' - source match at port 1

'SCORR3' - reflection tracking at port 1

'SCORR4' - reserved for future extensions

'SCORR5' - load match at port 2

'SCORR6' - forward transmission tracking between port 1 and port 2

'SCORR7' - directivity at port 2

'SCORR8' - source match at port 2

'SCORR9' - reflection tracking at port 2

'SCORR10' - reserved for future extensions

'SCORR11' - load match at port 1

'SCORR12' - reverse transmission tracking between port 2 and port 1

'G11' ... 'G22' - G matrix elements; see above

'H22' - H matrix elements; see above

The error terms are dimensionless complex numbers.

\*RST: n/a

<Parameter>

**Example:** See [\[SENSe<Ch>:\]CORRection:COLLect:SAVE:DEFault](#)

The different calibration types of the analyzer provide the following error terms:

| Calibration type                                           | Parameter in [SENSe<Ch>:]CORRection:COLLect:MEthod | Available error terms (depending on port numbers)                                             |
|------------------------------------------------------------|----------------------------------------------------|-----------------------------------------------------------------------------------------------|
| One-port normalization (reflection) using an open standard | REFL1<br>REFL2<br>REFL12                           | 'SCORR3'<br>'SCORR9'<br>'SCORR3' and 'SCORR9'                                                 |
| Full one port                                              | FOPort1<br>FOPort2<br>FOPort12                     | 'SCORR1' to 'SCORR3'<br>'SCORR7' to 'SCORR9'<br>'SCORR1' to 'SCORR3' and 'SCORR7' to 'SCORR9' |
| Two-port normalization                                     | FTRans<br>RTRans<br>FRTRans                        | 'SCORR6'<br>'SCORR12'<br>'SCORR6' and 'SCORR12'                                               |
| One path two port                                          | FOPTport<br>ROPTport                               | 'SCORR1' to 'SCORR3', 'SCORR6'<br>'SCORR7' to 'SCORR9', 'SCORR12'                             |

| Calibration type        | Parameter in [SENSe<Ch>:]CORRection:COLLect:MEtHod | Available error terms (depending on port numbers)                                                                                                                                                            |
|-------------------------|----------------------------------------------------|--------------------------------------------------------------------------------------------------------------------------------------------------------------------------------------------------------------|
| TOSM                    | TOSM                                               | 'SCORR1' to 'SCORR12'<br>(at present the isolation terms 'SCORR4' and 'SCORR10' are not included)                                                                                                            |
| TOM, TSM, TRM, TRL, TNA | TOM   TRM   TRL   TNA                              | 'DIRECTIVITY', 'SRCMATCH', 'REFLTRACK', 'LOADMATCH', 'TRANSTRACK' (for reading and writing)<br><br>'G11' ... 'G22' and 'H11', 'H12', 'H22' (for reading only; the 'H21' matrix elements are normalized to 1) |

---

**[SENSe<Ch>:]CORRection:OFFSet<PhyPt>:MAGNitude <OffsetLoss>**

Defines the frequency-independent part (DC value) of the offset loss.

**Tip:** Use the [SENSe<Ch>:]CORRection:LOSS<PhyPt>... commands to define the complete set of loss offset parameters.

[SENSe<Ch>:]CORRection:OFFSet<PhyPt>:MAGNitude is equivalent to [SENSe<Ch>:]CORRection:LOSS<PhyPt>:OFFSet.

**Suffix:**

<Ch> Channel number of the offset-corrected channel

<PhyPt> Port number of the analyzer

**Parameters:**

<OffsetLoss> Frequency-independent part of the offset loss

Range: -200 dB to +200 dB

Increment: 0.0001 dB

\*RST: 0 dB

Default unit: dB

---

**[SENSe<Ch>:]FREQuency:MODE <FreqSweep>**

Selects the sweep type and defines which set of commands controls the stimulus frequency.

**Tip:** The command [SENSe<Ch>:]SWEep:TYPE provides a complete list of sweep types.

**Suffix:**

<Ch> Channel number

**Parameters:**

<FreqSweep> CW | FIXed | SWEep | SEGment

Linear or logarithmic frequency sweep, depending on the selected spacing ([SENSe<Ch>:]SWEep:SPACing LINear | LOGarithmic). The frequency range is set via [SENSe<Ch>:]FREQuency:START etc.

**Example:**

```
FREQ:MODE CW
Activate a time sweep.
FREQ: CW 100MHz
Set the CW frequency to 100 MHz.
```

---

### [SENSe<Ch>:]SEGMENT<Seg>:CLEAr

Deletes all sweep segments in the channel. The command is equivalent to [\[SENSe<Ch>:\] SEGMENT<Seg>:DELeTe:ALL](#).

**Suffix:**

<Ch> Channel number

<Seg> Sweep segment number. This suffix is ignored; the command deletes all segments.

**Usage:** Event

---

### [SENSe<Ch>:]SEGMENT<Seg>:OVERlap <Boolean>

Queries whether the analyzer supports overlapping sweep segments.

**Suffix:**

<Ch> Channel number. This suffix is ignored; the command is instrument-specific.

<Seg> Sweep segment number. This suffix is ignored; the command is instrument-specific.

**Parameters:**

<Boolean> ON | OFF: No effect.

\*RST: ON. If used as a query, the command returns the information that overlapping sweep segments are supported (ON).

---

### [SENSe<Ch>:]SWEep:SPACing <StimulusFreq>

Defines the frequency vs. time characteristics of a frequency sweep ("Lin Frequency" or "Log Frequency"). The command has no effect on segmented frequency, power or time sweeps.

**Note:** Use [\[SENSe<Ch>:\] SWEep:TYPE](#) to select sweep types other than "Lin Frequency" or "Log Frequency".

**Suffix:**

<Ch> Channel number

**Parameters:**

<StimulusFreq> LINear | LOGarithmic

The stimulus frequency is swept in equidistant steps over the frequency range. In a Cartesian diagram, the x-axis is a linear frequency axis.

**Example:** `FUNC "XFR:POW:S12"`  
 Activate a frequency sweep and select the S-parameter  $S_{12}$  as measured parameter for channel and trace no. 1.  
`SWE:SPAC LOG`  
 Change to sweep type "Log Frequency".

---

**[SENSe<Chn>:]FUNcTION[:ON] <SweepType>[, <arg1>[, <arg2>]]**

Defines the sweep type and the measurement parameter in a single string.

**Note:** To select a measurement parameter without changing the sweep type, use `CALCulate<Ch>:PARAmeter:MEASure`. Use the other commands in the `CALCulate<Ch>:PARAmeter...` subsystem to create or delete traces and select measurement parameters.

**Suffix:**

**<Chn>** Channel number used to identify the active trace. If `[SENSe<Chn>:]FUNcTION[:ON]` is not used as a query, the number must be 1.

**Parameters:**

**<SweepType>** Single string parameter defining the sweep type and the parameter to be measured:

`<string> = "<sweep_type>:<parameter>"`.

Range: See list of strings below.

\*RST: "XFR:POW:S21"

**<arg1>** B1 | B2 | A1 | A2 | ABSa1 | ABSa2 | DCIN1 | DCIN2

**<arg2>** B1 | B2 | A1 | A2 | ABSa1 | ABSa2 | DCIN1 | DCIN2

**Example:** `CALC4:PAR:SDEF "Ch4Tr1", "S11"`  
 Create channel 4 and a trace named "Ch4Tr1" to measure the input reflection coefficient  $S_{11}$ . The trace automatically becomes the active trace.  
`SENS4:FUNC?`  
 Check (query) the sweep type and measurement parameter of the active trace. The result is 'XFR:POW:S11'.

The following keywords define the sweep type (see SCPI command reference: presentation layer):

|            |                                                                     |
|------------|---------------------------------------------------------------------|
| XFRequency | Frequency sweep (Lin. Frequency/Log. Frequency/Segmented Frequency) |
| XPOWer     | Power sweep                                                         |
| XTIME      | Time sweep                                                          |
| XCW?       | CW Mode sweep (output variable for query only)                      |

The following keywords define the measurement parameter (see SCPI command reference: function name):

|                                                                                   |                                                                                                                                           |
|-----------------------------------------------------------------------------------|-------------------------------------------------------------------------------------------------------------------------------------------|
| POWer:S<Ptout><Ptin>                                                              | S-parameter with output and input port number of the DUT, e.g. S <sub>11</sub> , S <sub>21</sub> .                                        |
| POWer:RATio A<Ptout>   B<Ptin>,<br>A<Ptout>   B<Ptin><br>Output: A<Ptout>/B<Ptin> | Ratio, e.g. B <sub>2</sub> , A <sub>1</sub> for b <sub>2</sub> /a <sub>1</sub> drive Port 1                                               |
| POWer:A<Ptout>                                                                    | Wave quantity with stimulus port number of the analyzer, e.g. a <sub>1</sub> .                                                            |
| POWer:B<Ptin>                                                                     | Wave quantity with receive port number of the analyzer, e.g. b <sub>2</sub> .                                                             |
| POWer:Z<Ptout><Ptin>                                                              | Matched-circuit impedance (converted Z-parameter) with output and input port number of the DUT, e.g. Z <sub>11</sub> , Z <sub>21</sub> .  |
| POWer:Y<Ptout><Ptin>                                                              | Matched-circuit admittance (converted Y-parameter) with output and input port number of the DUT, e.g. Y <sub>11</sub> , Y <sub>21</sub> . |
| POWer:KFACTOR<br>POWer:MUFactor<Lev>                                              | Stability factor K<br>Stability factors $\mu_1$ or $\mu_2$                                                                                |
| VOLTage[:DC] DCIN1   DCIN2<br>Output: DC 1 V, DC 10 V                             | DC Input 1 or 2                                                                                                                           |

**Note:** The mnemonics POWer: and VOLTage: are not used in output strings.

---

#### SOURce<Ch>:POWer<PhyPt>:CORRection:COLLect[:ACQuire] <Sensor>

Initiates a source power calibration for the source port <PhyPt> using an external power meter no. 1 or 2. To initiate a source power calibration for arbitrary power meters, use the alternative commands listed in the program example below.

**Note:** The command cannot be used unless a power meter is connected via GPIB bus, USB or LAN interface and configured in the "External Power Meters" dialog.

#### Suffix:

<Ch>                      Calibrated channel number

<PhyPt>                  Calibrated port number

#### Setting parameters:

<Sensor>                ASENSor | BSENSor

                             ASENSor – external power meter Pmtr 1.

                             BSENSor – external power meter Pmtr 2.

\*RST:                    ASENSor

- Example:**           SOUR:POW3:CORR:COLL BSEN  
Perform a source power calibration for port 3 using power meter no. 2.  
SOUR:POW:CORR:PMET:ID 2  
Select power meter no. 2.  
SOUR:POW:CORR:ACQ PORT, 3  
Perform a source power calibration for port 3 using the previously selected power meter no. 2.
- Usage:**            Setting only
- Manual operation:** See "[Start Cal Sweep](#)" on page 395

**TRACe:CLEAr** <MemTrace>

Deletes one of the memory traces Mem<n> [Trc<m>], where n = 1, ... 8.

**Setting parameters:**

<MemTrace>       MDATA1 | MDATA2 | MDATA3 | MDATA4 | MDATA5 | MDATA6 | MDATA7 | MDATA8

Identifier for the memory trace; see [Table 8-16](#).

Range:        MDATA<n> where <n> = 1 to 8.

- Example:**           SWE:POIN 20  
Create a trace with 20 sweep points, making the created trace the active trace of channel 1 (omitted optional mnemonic SENSE1).  
TRAC:COPY "Mem\_Pt20", CH1DATA  
Copy the current state of the created trace to a memory trace named "Mem\_Pt20". The memory trace is not displayed.  
DISP:WIND:TRAC2:FEED "MEM\_PT20"  
Display the created memory trace in the active diagram area (diagram area no. 1).

**Usage:**            Setting only

**TRACe[:DATA][:RESPonse][:ALL]?** <Response>

Returns the response values of the active data trace or memory trace (see [Table 8-16](#)).

**Note:** To read the response values of an arbitrary data or memory trace, use [CALCulate<Chn>:DATA](#). To read the response values of a trace acquired in single sweep mode ([INITiate<Ch>:CONTinuous OFF](#)), use [CALCulate<Chn>:DATA:NSweep:FIRSt?](#).



**Query parameters:**

<Response> CH1Data | CH2Data | CH3Data | CH4Data | CH1Mem | CH2Mem | CH3Mem | CH4Mem | MDATa1 | MDATa2 | MDATa3 | MDATa4 | MDATa5 | MDATa6 | MDATa7 | MDATa8

Response data of the selected trace, see [Table 8-16](#).  
The data is transferred in the data format defined via `FORMat[:DATA]` and `FORMat:DEXPort:SOURce`. The unit is the default unit of the measured parameter; see `CALCulate<Ch>:PARAmeter:SDEFine`.

**Example:**

```
SWE:POIN 20
```

Create a trace with 20 sweep points, making the created trace the active trace of channel 1 (omitted optional mnemonic `SENSe1`).

```
CALC:FORM MLIN; :FORM ASCII; FORM:DEXP:SOUR
FDAT
```

Select the trace data format: linear magnitude values, ASCII format and formatted trace data (1 value per sweep point).

```
TRAC? CH1DATA
```

Query the 20 response values of the created trace according to the previous format settings.

**Usage:**

Query only

**TRACe[:DATA]:STIMulus[:ALL]? <Stimulus>**

Returns the stimulus values of the active data trace or memory trace (see [Table 8-16](#)).

**Note:** To read the stimulus values of an arbitrary data or memory trace, use `CALCulate<Chn>:DATA:STIMulus?`

**Query parameters:**

<Stimulus> CH1Data | CH2Data | CH3Data | CH4Data | CH1Mem | CH2Mem | CH3Mem | CH4Mem | MDATa1 | MDATa2 | MDATa3 | MDATa4 | MDATa5 | MDATa6 | MDATa7 | MDATa8

Stimulus data of the selected trace, see [Table 8-16](#).  
The data is transferred in the data format defined via `FORMat[:DATA]`.

**Example:**

```
SWE:POIN 20
```

Create a trace with 20 sweep points, making the created trace the active trace of channel 1 (omitted optional mnemonic `SENSe1`).

```
TRAC:STIM? CH1DATA
```

Query the 20 stimulus values of the created trace. In the default format setting, the data is returned as a comma-separated list of 10-digit ASCII values.

**Usage:**

Query only

## 9 Programming Examples

This chapter contains detailed programming examples on various tasks.

The syntax and use of all SCPI commands is described in [Chapter 8, "Command Reference"](#), on page 594, where you will also find additional examples. For a general introduction to remote control of the analyzer refer to [Chapter 7, "Remote Control"](#), on page 559. For an overview of special remote control features of the network analyzers refer to [Chapter 7.3, "Basic Remote Control Concepts"](#), on page 572.

### 9.1 Basic Tasks

This section presents detailed examples for programming tasks that almost every user will encounter when working with the R&S ZND.

#### 9.1.1 Typical Stages of a Remote Control Program

A typical remote control program comprises the following stages:

1. Performing the basic instrument settings
2. Adjusting the test setup
3. Initiating the measurement, command synchronization
4. Retrieving measurement results

Very often, steps 3 and 4 (or steps 2 to 4) must be repeated several times.



All example programs in this section have been developed and tested by means of the GPIB Explorer provided with the network analyzer. No extra programming environment is needed.

##### 9.1.1.1 Basic Instrument Settings

**Programming task:** Adjust the basic network analyzer settings to your measurement tasks, optimizing the instrument for fast measurements.



### Considerations for high measurement speed

The measurement speed depends on the sweep time but also on an efficient preparation of the instrument and on proper command synchronization. The following items should be kept in mind:

- For maximum speed the basic channel settings should be set while the sweep is stopped and with a minimum of sweep points. It is advisable to increase the number of points after all instrument settings have been performed, and to initiate the sweep after the test setup has been completed.
- Execution of the `INITiate[:IMMEDIATE]` command is fastest in synchronized mode. Insertion of fixed waiting periods into the command sequence is possible but generally less efficient.
- The sweep time depends on several parameters; see below. In particular it is recommended to select the best set of sweep points, e.g. using the segmented sweep.

```
// Reset the instrument, switch off the measurement (after one sweep),
// reduce the number of sweep points.
*RST
INITiate1:CONTinuous OFF
SENSe1:SWEep:POINts 2
//
// Avoid a delay time between different partial measurements and before the
// start of the sweeps (is default setting).
SENSe1:SWEep:TIME:AUTO ON
TRIGger1:SEQuence:SOURce IMMEDIATE
//
// Select the widest bandwidth compatible with your measurement.
SENSe1:BANDwidth:RESolution 10
//
// Adjust your sweep points to your measurement task, e.g. using a segmented sweep.
SENSe1:SEGment...
```

#### 9.1.1.2 Adjusting the Test Setup

In general the preparatives described above can be used for a series of measurements. In-between the measurements it is often necessary to change the test setup, e.g. to replace the DUT, change the connected ports, connect external devices etc.

#### 9.1.1.3 Start of the Measurement and Command Synchronization

Programming task: Start a measurement in single sweep mode. Wait until all single sweep data has been acquired before you proceed to the next stage of the measurement.

`INITiate<Ch>[:IMMEDIATE][:DUMMY]` or `INITiate<Ch>[:IMMEDIATE]:ALL` are used to start a single sweep or a group of single sweeps. These commands have

been implemented for overlapped execution. The advantage of overlapped commands is that they allow the program to do other tasks while being executed.

In the present example the sweep must be completed before measurement results can be retrieved. To prevent wrong results (e.g. a mix-up of results from consecutive sweeps) the controller must synchronize its operation to the execution of `INITiate<Ch>[:IMMEDIATE]`. IEEE 488.2 defines three common commands (`*WAI`, `*OPC?`, `*OPC`) for synchronization.

### // 1. Start single sweep, use \*WAI

```
// *WAI is the easiest method of synchronization. It has no effect when sent
// after sequential commands.
// If *WAI follows INITiate<Ch>[:IMMEDIATE]... (overlapped commands), the analyzer
// executes no further commands or queries until the sweep is terminated.
// *WAI does prevent the controller from sending other commands to the analyzer
// or other devices

// Start single sweep in channel no. 1, wait until the end of the sweep
INITiate1:IMMEDIATE; *WAI
<Continue program sequence>
```

### // 2. Start single sweep, use \*OPC?

```
// If *OPC follows INITiate<Ch>[:IMMEDIATE]..., it places a 1 into the
// output queue when the sweep is terminated.
// An appropriate condition in the remote control program must cause the
// controller to wait until *OPC? returns one.
// The controller is stopped from the moment when the condition is set.

// Start single sweep in channel no. 1, indicate the end of the sweep
// by a 1 in the output queue.
INITiate1:IMMEDIATE; *OPC?
// So far the controller may still send messages to other connected devices.

// Stop the controller until *OPC? returns one (program syntax depends
// on your programming environment).
<Condition OPC=1>
<Continue program sequence>
```

### // 3. Start single sweep, use \*OPC

```
// If *OPC follows INITiate<Ch>[:IMMEDIATE]..., it sets the OPC bit in the ESR
// after the sweep is terminated.
// This event can be polled or used to trigger a service request of the analyzer.
// The advantage of *OPC synchronization is that both the controller and the
// analyzer can continue processing commands while the sweep is in progress.

// Enable a service request for the ESR
*SRE 32
// Set event enable bit for operation complete bit
```

```

*ESE 1
// Start single sweep in channel no. 1, set the OPC bit in the ESR
// after the sweep is terminated.
// The controller may still send messages, the analyzer continues to parse
// and execute commands.
INITiate1:IMMediate; *OPC

// Controller waits for service request from the analyzer
// (program syntax depends on your programming environment).
<Wait for service request>
<Continue program sequence>

```

#### 9.1.1.4 Retrieving Measurement Results

**Programming task:** Read the results acquired in a single sweep.

##### // 1. Read single values (-> Markers)

```

// Markers are the most convenient tool for determining and retrieving single
// values on traces.
// The analyzer provides up to ten markers; see Markers and Limit Lines.

```

##### // 2. Read complete trace

```

// Select a trace format and read formatted trace data.
CALCulate1:FORMat MLINear / Calculate the linear magnitude of z
CALCulate1:DATA? FDATA / Read the formatted trace data

```



Use `CALCulate<Chn>:DATA:NSweep:FIRSt?` to retrieve a particular trace within a group of sweeps.

### 9.1.2 Channel, Trace and Diagram Handling

The following examples show you how to perform basic tasks related to channel and trace definition and to the display of traces in diagrams.



All example programs in this section have been developed and tested by means of the GPIB Explorer provided with the network analyzer. No extra programming environment is needed.

#### 9.1.2.1 Several Traces with Equal Channel Settings

**Programming task:** Create up to four different traces with equal channel settings, assign the four 2-port standard S-parameters to the traces and display them in up to four diagrams.

### Important remote control features for this program example

The following command sequence illustrates the structure of the remote commands discussed in section Basic Remote Control Concepts. In particular it shows that:

- A trace can be created and handled without being displayed.
- Traces are referenced by trace names. The active trace of a channel is often referenced by the channel suffix.
- Diagrams are referenced by a window suffix <Wnd>. An additional suffix <WndTr> in the DISPLAY:WINDOW<Wnd>:TRACE<WndTr>... commands numbers the different traces in a diagram.
- In remote control, it is possible to display the same trace in several diagrams.
- The analyzer provides several commands allowing a smooth transition between remote and manual control.

#### // 1. One channel, two traces, one diagram

```
// Reset the instrument, creating the default trace Trc1 in channel 1.
// The default measured quantity is the forward transmission S-parameter S21.
// The default format is dB Mag.
*RST

// Create a second trace in channel 1, assign the format Phase,
// and display the new trace in the same diagram.
// the trace becomes the active trace but is not displayed
CALCulate1:PARAMeter:SDEFine 'Trc2', 'S21'

// the trace is referenced by the channel suffix 1
CALCulate1:FORMat PHASE

// display the second trace, numbering it the second trace in diagram no. 1
DISPlay:WINDow1:TRACe2:FEED 'Trc2'
```

#### // Check the result on the local screen

```
// Go to local
SYSTem:DISPlay:UPDate ONCE
```

#### // 2. One channel, two traces, two diagrams

```
// Create a second diagram, assign Trc2 to the new area, and remove it
// from the first area.
DISPlay:WINDow2:STATe ON
DISPlay:WINDow2:TRACe2:FEED 'Trc2'
// Trc2 is now displayed in both diagrams
DISPlay:WINDow1:TRACe2:DELeTe
```

#### // Check the result on the local screen

```
// Go to local
SYSTem:DISPlay:UPDate ONCE
```

**// 3. One channel, four traces, four diagrams**

```
// Reset the instrument, add diagrams no. 2, 3, 4.
*RST; :DISPlay:WINDow2:STATe ON
DISPlay:WINDow3:STATe ON
DISPlay:WINDow4:STATe ON

// Assign the reflection parameter S11 to the default trace.
:CALCulatel:PARAmeter:MEASure 'Trc1', 'S11'

// Assign the remaining S-parameters to new traces Trc2, Trc3, Tr4;
// select the Smith chart format for the reflection parameters.
CALCulatel:FORMat SMITH // Smith chart for the active trace Trc1
CALCulatel:PARAmeter:SDEFine 'Trc2', 'S21'
CALCulatel:PARAmeter:SDEFine 'Trc3', 'S12'
CALCulatel:PARAmeter:SDEFine 'Trc4', 'S22'
// Smith chart for the active trace Trc4, referenced by the channel number
CALCulatel:FORMat SMITH

// Display the new traces in diagrams no. 2 to 4.
DISPlay:WINDow2:TRACe2:FEED 'Trc2'
DISPlay:WINDow3:TRACe3:FEED 'Trc3'
DISPlay:WINDow4:TRACe4:FEED 'Trc4'
```

**// Check the result on the local screen**

```
// Go to local
SYSTem:DISPlay:UPDate ONCE
```

**9.1.2.2 Several Traces with Different Channel Settings...**

**Programming task:** Create three channels with 3, 1 and 2 traces, respectively, and display the traces in two diagrams.

**Important remote control features for this program example**

The following command sequence illustrates the structure of the remote commands discussed in section Basic Remote Control Concepts. In particular it shows that:

1. Channels are always referenced by a channel suffix.
2. Traces are referenced by trace names. The active trace of a channel is often referenced by the channel suffix.
3. Diagrams are referenced by a window suffix <Wnd>. An additional suffix <WndTr> in the `DISPlay:WINDow<Wnd>:TRACe<WndTr>...` commands numbers the different traces in a diagram.
4. The analyzer provides several commands allowing a smooth transition between remote and manual control.

**// 1. Create all channels and traces**

```
// Reset the instrument, creating the default trace Trc1 in channel 1.
// The default measured quantity is the forward transmission S-parameter S21.
// The default format is dB Mag.
*RST

// Create two more traces in channel 1, assigning a trace name and a measured
// quantity to each of them. Choose descriptive trace names (instead of the
// short default names used above).
CALCulate1:PARAMeter:SDEFine 'Impedance_trace', 'Z-S21'
// the trace becomes the active trace for channel 1 but is not displayed

CALCulate1:PARAMeter:SDEFine 'Admittance_trace', 'Y-S21'
// the trace becomes the active trace for channel 1

// Create channel 2 with one new trace, channel 3 with two new traces.
CALCulate2:PARAMeter:SDEFine 'Ratio_trace', 'B1/B2'
CALCulate3:PARAMeter:SDEFine 'Z_trace', 'Z21'
CALCulate3:PARAMeter:SDEFine 'Y_trace', 'Y21'
CALCulate3:PARAMeter:SElect 'Z_trace'
// the trace created previously becomes the active trace for channel 3
// So far, only the default trace is displayed.
```

**// Check the result on the local screen**

```
// Go to local
SYSTem:DISPlay:UPDate ONCE
```

**// 2. Create second diagram and display traces**

```
DISPlay:WINDow2:STATe ON
DISPlay:WINDow1:TRACe2:FEED 'Admittance_trace'
DISPlay:WINDow1:TRACe3:FEED 'Y_trace'
DISPlay:WINDow2:TRACe1:FEED 'Impedance_trace'
DISPlay:WINDow2:TRACe2:FEED 'Ratio_trace'
DISPlay:WINDow2:TRACe3:FEED 'Z_trace'
```

**// Check the result on the local screen**

```
// Go to local
SYSTem:DISPlay:UPDate ONCE
```

**// 3. Check and modify your configuration**

```
// Query the traces in channel 1.
CALCulate1:PARAMeter:CATalog?
// The response is 'Trc1,S21,Impedance_trace,Z-S21,Admittance_trace,Y-S21'

// Query the reference level for the 'Z_trace'.
// The trace is referenced by its number in diagram no. 2.
DISPlay:WINDow2:TRACe3:Y:RLEVEL?
```



```
// Change the display format for the 'Z_trace'. The trace is the active trace
// in channel 3, so it is referenced by the channel suffix 3.
// Update the display
CALCulate3:FORMat PHASe
// Update the display
SYSTem:DISPlay:UPDate ONCE
```

### 9.1.2.3 Markers and Limit Lines...

**Programming task:** Display two traces in a single diagram area, use markers to read results, and perform a limit check.

#### Important remote control features for this program example

The following command sequence illustrates the structure of the remote commands discussed in section Basic Remote Control Concepts. In particular it shows that:

1. Traces are referenced by trace names. The active trace of a channel is often referenced by the channel suffix. This simplifies the program syntax, e.g. in the commands for marker settings and for the limit check.
2. Diagrams are referenced by a window suffix <Wnd>. An additional suffix <WndTr> in the DISPLAY:WINDOW<Wnd>:TRACE<WndTr>... commands numbers the different traces in a diagram.
3. The analyzer provides several commands allowing a smooth transition between remote and manual control.

#### // 1. Create one channel, two traces, one diagram

```
// Reset the instrument, creating the default trace Trc1 in channel 1.
// The default measured quantity is the forward transmission S-parameter S21.
// The default format is dB Mag.
*RST

// Create a second trace in channel 1, assign the format Phase,
// and display the new trace in the same diagram.

// the trace becomes the active trace but is not displayed
CALCulate1:PARAMeter:SDEFine 'Trc2', 'S21'

// the trace is referenced by the channel suffix 1
CALCulate1:FORMat PHASe

// display the second trace, numbering it the second trace in diagram no. 1
DISPlay:WINDOW1:TRACE2:FEED 'Trc2'
```

#### // Check the result on the local screen

```
// Go to local
SYSTem:DISPlay:UPDate ONCE
```

**// 2. Marker settings**

```
// Adjust the sweep range to consider an interesting segment of the trace and
// re-scale the diagram.
SENSE1:FREQUENCY:START 4.5 GHz; STOP 5.5 GHz
// in the autoscale command the trace is referenced by its number in the diagram
DISPLAY:WINDOW1:TRACE1:Y:SCALE:AUTO ONCE

// Select trace Trc1 as the active trace of the channel, define a reference
// marker and a delta marker.
// In the marker commands the active trace is referenced by the channel suffix.
CALCULATE1:PARAMETER:SELECT 'Trc1'

// the marker is set to the center of the sweep range
CALCULATE1:MARKER1:STATE ON

// this command also creates the reference marker
CALCULATE1:MARKER1:DELTA:STATE ON

// set the reference marker to the beginning of the sweep range
CALCULATE1:MARKER1:REFERENCE:X 4.5 GHz

// Use the delta marker to search for the minimum of the trace and query the result.
// the query returns the stimulus and the response value at the marker position
CALCULATE1:MARKER1:FUNCTION:EXECUTE MIN; RES?
```

**// Check the result on the local screen**

```
// Go to local
SYSTEM:DISPLAY:UPDATE ONCE
```



Use the `CALCULATE<Chn>:DATA...` commands to retrieve the complete trace; see [Retrieving Measurement Results](#).

**// 3. Limit lines and limit check**

```
// Remove all markers and define a limit line for the active trace.
CALCULATE1:MARKER1:AOFF
// define an upper limit line across the entire sweep range
CALCULATE1:LIMIT:DATA 1, 4500000000, 5500000000, -5, -5
CALCULATE1:LIMIT:DATA 2, 4500000000, 5000000000, -10, -15
// define two segments for the lower limit line
CALCULATE1:LIMIT:DATA 2, 5000000000, 5500000000, -15, -10

// Display the limit line and perform the limit check.
CALCULATE1:LIMIT:DISPLAY:STATE ON
CALCULATE1:LIMIT:STATE ON; FAIL?
// if the trace failed the limit check; the response is 1
```

```
// Check the result on the local screen
```

```
// Go to local
SYSTem:DISPlay:UPDate ONCE
```

## 9.2 Condensed Programming Examples

This section contains short program examples for select issues. The comments have been commented in concise style; for more detailed information on the commands refer to [Chapter 8.3, "SCPI Command Reference"](#), on page 597.

If the example you are looking for is not in this section, we suggest you to refer to the short command sequences in the reference chapter. Proceed as follows:

1. Find your subject in the help system, preferably using context-sensitivity (of the help system on your network analyzer) or the index:

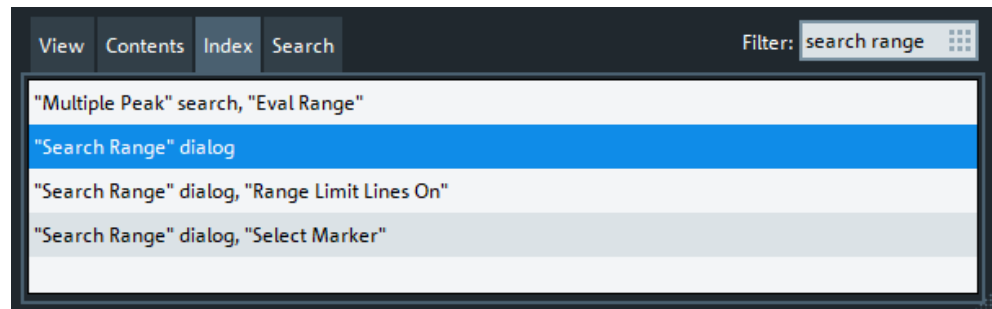

2. Activate the link to the command description:

Remote command:

```
CALCulate<Chn>;MARKer<Mk>;FUNction:DOMain:USER\[RANGE\]
CALCulate<Chn>;MARKer<Mk>;FUNction:DOMain:USER:START
CALCulate<Chn>;MARKer<Mk>;FUNction:DOMain:USER:STOP
```

3. A short example appears at the end of each command description:

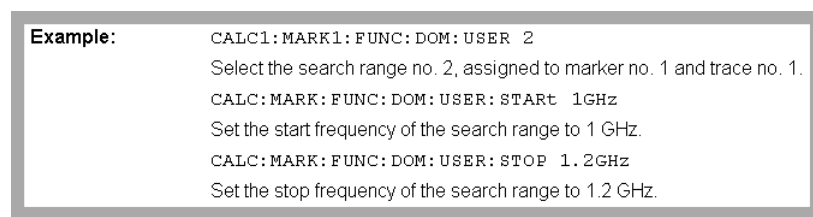

The command `SYSTem:DISPlay:UPDate` precedes some of the command scripts so that you can watch the progress of the script on the screen. For maximum performance, simply omit this command.

## 9.2.1 Path Independent RC Programs

The default directory for R&S ZND user data is

C:\Users\Public\Documents\Rohde-Schwarz\Vna. Other instruments may use different default directories. To make remote control programs compatible, it is recommended to define all paths relative to the default directory, to be set via `MMEemory:CDIRectory DEFault`.

**// Select default directory, change to sub-directory (relative to default directory)**

```
MMEemory:CDIRectory DEFault
MMEemory:CDIRectory 'Traces'

MMEemory:STORe:TRACe 'Trc1', 'S21.s1p'
MMEemory:LOAD:TRACe 'Trc1', 'S21.s1p'
```

**// Alternative, more compact definition**

```
MMEemory:CDIRectory DEFault
MMEemory:STORe:TRACe 'Trc1', 'Traces\S21.s1p'
```

You may also read the default path (`MMEemory:CDIRectory?`) and use the external RC program to build the complete paths.

## 9.2.2 Trace and Diagram Handling

The following sections provide examples for efficient channel and trace definition and convenient diagram handling.

### 9.2.2.1 Assigning Channels, Traces, and Diagrams

The following example is a short version of [Chapter 9.1.2, "Channel, Trace and Diagram Handling"](#), on page 1113.

**// Reset the analyzer**

```
*RST
:SYSTEM:DISPLAY:UPDATE ON
```

**// Create a new trace for S21 with the name TrcDisp**

```
:CALCULATE1:PARAMETER:SDEFINE "TrcDisp","S21"
// Display the trace in the display area 1
:DISPLAY:WINDOW1:TRACE9:FEED 'TrcDisp'
:DISPLAY:WINDOW1:TRACE9:DELETE
```

**// List the traces, assigned to a certain Channel**

```
// format "<trace name>,<meas param>[,<trace name>,<meas param>...]"
:CALCULATE1:PARAMETER:CATALOG?
```

**// Channel 4 does not exist, a new channel and trace is created**

```
:CALCULATE4:PARAMETER:SDEFINE "Ch4Trc2","S22"
:CALCULATE4:PARAMETER:SDEFINE "Ch4Trc3","S33"
:CALCULATE4:PARAMETER:CATALOG?
```

**// Select active traces for channel 4**

```
:CALCULATE4:PARAMETER:SELECT "Ch4Trc2"
:CALCULATE4:PARAMETER:SELECT?
//:CALCULATE4:FORMAT POLAR
:CALCULATE4:PARAMETER:SELECT "Ch4Trc3"
//:CALCULATE4:FORMAT DB_LIN
:CALCULATE4:PARAMETER:SELECT?
:CALCULATE4:PARAMETER:SELECT "Ch4Trc2"
:CALCULATE4:FORMAT?
:CALCULATE4:PARAMETER:SELECT "Ch4Trc3"
:CALCULATE4:FORMAT?
```

**// Create trace**

```
:CALCULATE1:PARAMETER:SDEFINE "Trc2","S21"
:CALCULATE1:PARAMETER:SDEFINE "Trc3","S31"
:CALCULATE1:PARAMETER:CATALOG?
```

**// Delete trace**

```
:CALCULATE1:PARAMETER:DELETE "Trc2"
:CALCULATE1:PARAMETER:CATALOG?
```

**// Assign a trace to a window = diagram, diagram 1 always exists**

```
:DISPLAY:WINDOW1:TRACE2:FEED 'TrcDisp'
```

**// Create diagram 2**

```
:DISPLAY:WINDOW2:STATE?
:DISPLAY:WINDOW2:STATE ON
:DISPLAY:WINDOW2:STATE?
:DISPLAY:WINDOW2:TRACE6:FEED 'Ch4Trc2'
:DISPLAY:WINDOW2:TRACE2:FEED 'Trc1'
:DISPLAY:WINDOW2:TRACE3:FEED 'Ch4Trc3'
```

**// Create traces: trace names are not case-sensitive**

```
:CALCULATE4:PARAMETER:SELECT "Ch4Trc2"
:CALCULATE4:PARAMETER:SELECT?
:CALCULATE4:PARAMETER:SELECT "CH4TRC3"
:CALCULATE4:PARAMETER:SELECT?
:CALCULATE4:PARAMETER:SELECT "ch4trc2"
:CALCULATE4:PARAMETER:SELECT?
```

### 9.2.2.2 Memory Traces

The following example shows how to save data to memory and work with memory traces.

#### // Reset the analyzer

```
*RST
:SYSTEM:DISPLAY:UPDATE ON
:SENSE1:SWEEP:POINTS 20
```

#### // Create memory trace of the "active" trace (active for the parser !)

```
// the name of the created memory trace is "Mem2[Trc1]"
:TRACE:COPY MDATA2,CH1DATA
:SENSE1:FUNCTION:ON 'XFREQUENCY:POWER:S11'
:CALCULATE1:PARAMETER:CATALOG?

// Assign the memory trace to a window = diagram, diagram 1 always exists
:DISPLAY:WINDOW1:TRACE2:FEED 'Mem2[Trc1]'
```

#### // Create further memory traces and assign them to a window

```
:TRACE:COPY 'Mem3x[Trc1]',CH1DATA // mixed parameters String, Char
:DISPLAY:WINDOW1:TRACE3:FEED 'Mem3x[Trc1]'
:TRACE:COPY MDATA4,CH1DATA
:DISPLAY:WINDOW1:TRACE4:FEED 'Mem4[Trc1]'
```

#### // Create new normal trace on channel 1, assign it to a window

```
:CALCULATE1:PARAMETER:SDEFINE "Trc2","S22"
:DISPLAY:WINDOW1:TRACE5:FEED 'Trc2'
:CALCULATE1:PARAMETER:SELECT 'Trc2' // now active for channel 1
:CALCULATE1:PARAMETER:SELECT?
:CALCULATE1:PARAMETER:CATALOG?
```

#### // Create memory trace for 'Trc2',

```
// The memory trace can be assigned to the diagram of the mother trace only
// (diagram 1)
:TRACE:COPY MDATA6,CH1DATA
:DISPLAY:WINDOW1:TRACE6:FEED 'Mem6[Trc2]'
```

#### // Create new diagram 2 and new channel and trace

```
:DISPLAY:WINDOW2:STATE ON
:CALCULATE2:PARAMETER:SDEFINE "Ch2Trc1","S22"
:CALCULATE2:PARAMETER:SELECT 'Ch2Trc1' // now active for channel 2
:SENSE1:SWEEP:POINTS 21
:TRACE:COPY MDATA1,CH2DATA
:DISPLAY:WINDOW2:TRACE7:FEED 'Mem1[Ch2Trc1]'
```

```
:TRACE:DATA:STIMULUS? CH1DATA
:TRACE:DATA:RESPONSE? MDATA6
```

### // Create new channel 3 and new trace

```
:CALCULATE3:PARAMETER:SDEFINE "Ch3Trc1","S21"
:CALCULATE3:PARAMETER:SELECT 'Ch3Trc1' // now active for channel 3
:CALCULATE3:PARAMETER:SELECT? '%Ch3Trc1'
:SENSE1:SWEEP:POINTS 22
:TRACE:COPY MDATA8,CH3DATA
:TRACE:COPY MDATA7,CH3DATA
:DISPLAY:WINDOW2:TRACE1:FEED 'Mem8[Ch3Trc1]'
:TRACE:DATA:RESPONSE? MDATA7 // assigned to no diagram
```

### // Copy with arbitrary trace names, no blanks in trace names !!!

```
:TRACE:COPY 'Trace_Name','Ch3Trc1'
:DISPLAY:WINDOW2:TRACE2:FEED 'Trace_Name'
:CALCULATE3:PARAMETER:SELECT 'Trace_Name'
:CALCULATE3:PARAMETER:SELECT?
:TRACE:COPY 'XYZ','Ch2Trc1'
:DISPLAY:WINDOW2:TRACE3:FEED 'XYZ'
:CALCULATE2:PARAMETER:SELECT 'XYZ'
:CALCULATE2:PARAMETER:SELECT?
:TRACE:COPY MDATA4 , 'Ch3Trc1' // mixed parameters Char, String
:DISPLAY:WINDOW2:TRACE4:FEED 'Mem4[Ch3Trc1]'
```

### // Copy to existing memory traces = update trace data

```
:TRACE:COPY MDATA6,CH1DATA
:TRACE:COPY 'XYZ','Ch2Trc1'
:CALCULATE1:PARAMETER:CATALOG?
:CALCULATE2:PARAMETER:CATALOG?
:CALCULATE3:PARAMETER:CATALOG?
```

## 9.2.2.3 Trace Mathematics

The following script shows how to define mathematical relations between traces.

### // Reset the analyzer

```
*RST
:SYSTEM:DISPLAY:UPDATE ON
```

### // Create memory trace on active trace of channel 1,

```
// assign the memory trace to a diagram
:CALCULATE1:MATH:MEMORIZE
:DISPLAY:WINDOW1:TRACE2:FEED 'Mem2[Trc1]'
```

**// Define simple trace mathematics**

```
:CALCULATE1:MATH:FUNCTION ADD
:CALCULATE1:MATH:FUNCTION?
// Trace mathematics off
:CALCULATE1:MATH:FUNCTION NORMAL
:CALCULATE1:MATH:FUNCTION?
*RST
```

**// Create Trc2 in channel 1 and display it in diagram 1**

```
:CALCULATE1:PARAMETER:SDEFINE "Trc2","S11"
:DISPLAY:WINDOW1:TRACE2:FEED 'Trc2'
```

**// Create diagram 2 and Trc3 in new channel**

```
:DISPLAY:WINDOW2:STATE ON
:CALCULATE2:PARAMETER:SDEFINE "Trc3","S11"
:DISPLAY:WINDOW2:TRACE1:FEED 'Trc3'
```

**// Select active traces for channels 1 and 2**

```
:CALCULATE1:PARAMETER:SELECT "Trc1"
:CALCULATE2:PARAMETER:SELECT "Trc3"
```

**// Create memory trace on Trc1 and assign it to a diagram, same for TRC3**

```
:TRACE:COPY MDATA7,CH1DATA
:DISPLAY:WINDOW1:TRACE3:FEED 'Mem7[Trc1]'
:TRACE:COPY MDATA8,CH2DATA
:DISPLAY:WINDOW2:TRACE2:FEED 'Mem8[Trc3]'
```

**// Examples for Trace Mathematics**

```
// Special operands Data and Mem
:CALCULATE1:MATH:SDEFINE "Data * Mem"
:CALCULATE1:MATH:STATE ON
// Constants
:CALCULATE1:MATH:SDEFINE "Pi * e * j"
// Functions
:CALCULATE1:MATH:SDEFINE "linMag (1) + dBMag (2) + Arg (3) + Re (4) + Im (5j)"
:CALCULATE1:MATH:SDEFINE "log (2) * ln (3) * Min (1, 2) * Max (2, 3)"
:CALCULATE1:MATH:SDEFINE "StimVal + asin (sin (3)) + acos (cos (4))
 + atan (tan (4))"
:CALCULATE1:MATH:SDEFINE "(Trc1 + 2) * 1.1"
:CALCULATE1:MATH:SDEFINE "(tRC1 + e) * Pi + STIMVAL - sin (1) + Min (TRC1, Trc1)"
// Imaginary unit j = sqrt (-1)
// j is no ordinary operand: 1j not 1 * j
// magnitude: 1, phase: 60 degrees
:CALCULATE1:MATH:SDEFINE "(1 + 3 ^ (1 / 2) * 1j) / 2"
:CALCULATE1:MATH:SDEFINE "sin (1) + ACOS (0.5)"
// 2 periods for sin (), ... when stop frequency 8 GHz = 8e9 Hz
```



```

:CALCULATE1:MATH:SDEFINE "sin (2 * 2 * Pi * StimVal / 8e9) "
:CALCULATE1:MATH:SDEFINE "cos (2 * 2 * Pi * StimVal / 8e9) "
:CALCULATE1:MATH:SDEFINE "tan (2 * 2 * Pi * StimVal / 8e9) "
:CALCULATE1:MATH:SDEFINE "Min (sin (6 * Pi * StimVal / 8e9),
 cos (6 * Pi * StimVal / 8e9))"
:CALCULATE1:MATH:SDEFINE "Max (sin (6 * Pi * StimVal / 8e9),
 cos (6 * Pi * StimVal / 8e9))"
:CALCULATE1:MATH:SDEFINE "Trc1 ^ 2"
:CALCULATE1:MATH:SDEFINE "Trc1 + Trc2 + Trc3"
:CALCULATE1:MATH:SDEFINE "(Trc1 + e) * Pi + Mem8[Trc3] + StimVal
 + Min (Trc1, Mem7[Trc1])"
:CALCULATE1:MATH:SDEFINE "tan (5 * 2 * Pi * StimVal / 8e9)"

```

#### 9.2.2.4 Trace Statistics

The following script shows how to create a trace, select an evaluation range and retrieve statistical results.

##### // Reset the analyzer

```

*RST
:SYSTEM:DISPLAY:UPDATE ON

```

##### // Create new channel and trace

```

:CALCULATE2:PARAMETER:SDEFINE 'Trc2', 'S11'
:CALCULATE2:PARAMETER:SELECT 'Trc2'
:DISPLAY:WINDOW2:STATE ON
:DISPLAY:WINDOW2:TRACE1:FEED 'Trc2'
:SENSE1:SWEEP:TIME:AUTO ON
:SENSE2:SWEEP:TIME:AUTO ON

```

##### // Search full-span evaluation range, display statistical results

```

:CALCULATE1:STATISTICS:DOMAIN:USER 0
:CALCULATE2:STATISTICS:DOMAIN:USER 0
:CALCULATE1:STATISTICS ON
:CALCULATE2:STATISTICS ON

```

##### // Single sweep, global scope

```

:INITIATE:CONTINUOUS OFF
:INITIATE:IMMEDIATE:SCOPE ALL
:SENSE:SWEEP:COUNT 4
:INITIATE:IMMEDIATE; *WAI

```

##### // Calculate statistical results (also possible if info field is switched off)

```

:CALCULATE1:STATISTICS:RESULT? MEAN
:CALCULATE1:STATISTICS:RESULT? ELENGth
:CALCULATE1:STATISTICS:RESULT? ALL

```

**// Modify evaluation range (is automatically confined to sweep range)**

```
:CALCulate1:STATistics:DOMain:USER 1
:CALCulate1:STATistics:DOMain:USER:START 0 HZ
:CALCulate1:STATistics:DOMain:USER:STOP 100 GHZ
:CALCulate1:STATISTICS:RESULT? MEAN

:CALCulate1:STATISTICS:RESULT? MAX
```

**9.2.2.5 Bandfilter Search**

The following example shows how to use markers for a bandpass or bandstop search.

**// Reset the analyzer**

```
*RST
:SYSTEM:DISPLAY:UPDATE ON

:SENSE1:FREQUENCY:START 1 GHZ
:SENSE1:FREQUENCY:STOP 6 GHZ
```

**// Bandpass search ref. to max.**

```
:CALCulate1:MARKer:FUNction:BWIDth:MODE BPASS
:CALCulate1:MARKer:FUNction:BWIDth:MODE? %BPAS

// Measure single sweep, wait until complete sweep is finished
:INITiate:CONTinuous OFF
:INITiate; *WAI;
:CALCulate1:MARKer:FUNction:EXECute BFILter

// All markers OFF
:CALCulate1:MARKer:AOFF
```

**// Bandpass search ref. to marker**

```
:CALCulate1:MARKer1:STATe ON
:CALCulate1:MARKer1:X 3.0 GHz
:CALCulate1:MARKer:FUNction:BWIDth:MODE BPRMarker
:CALCulate1:MARKer:FUNction:BWIDth:MODE? %BPRM
:INITiate; *WAI;
:CALCulate1:MARKer:FUNction:EXECute BFILter
:CALCulate1:MARKer:AOFF
```

**// Bandstop search ref. to max.**

```
:CALCulate1:MARKer:FUNction:BWIDth:MODE BStop
:CALCulate1:MARKer:FUNction:BWIDth:MODE? %BST
:INITiate; *WAI;
:CALCulate1:MARKer:FUNction:EXECute BFILter
:CALCulate1:MARKer:AOFF
```

**// Bandstop search ref. to marker**

```

:CALCulate1:MARKer1:STATE ON
:CALCulate1:MARKer1:X 1.7 GHz
:CALCulate1:MARKer:FUNCTion:BWIDth:MODE BsRMarker
:CALCulate1:MARKer:FUNCTion:BWIDth:MODE? %BsRM
:INITiate; *WAI;
:CALCulate1:MARKer:FUNCTion:EXECute BFILter

```

**9.2.2.6 Creating Diagrams**

In the following example, remote control commands are used to position several diagrams on the screen. The remote control commands presented here extend the functionality of the "Display > Diagram" and "Display > Split" softtool tabs.

**// Reset the analyzer**

```

*RST
:SYSTEM:DISPLAY:UPDATE ON

```

**// Define and display a simple horizontal layout (two diagrams side by side)**

```

:DISPlay:LAYout:DEFine 1, Horizontal, '1.00,0.30,0.70'
:DISPlay:LAYout:APPLY 1

```

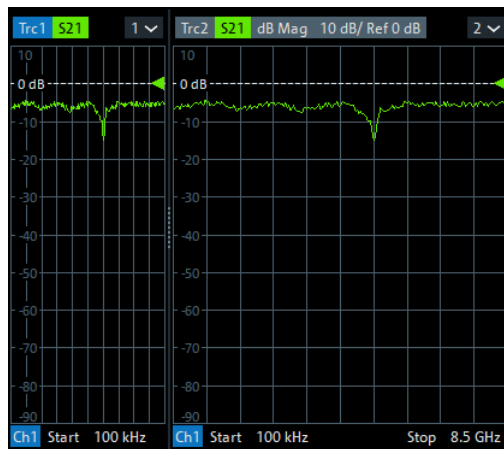
**// Define and display a simple vertical layout (two diagrams, one on top of the other)**

```

:DISPlay:LAYout:DEFine 2, Vertical, '1.00,0.50,0.50'
:DISPlay:LAYout:APPLY 2

```

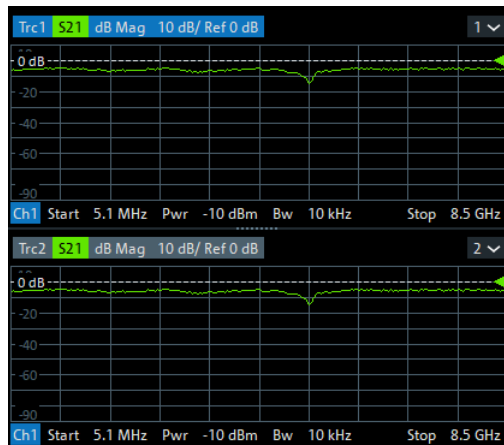

### // Check the executable formats of the generated layouts

```
:DISPlay:LAYout:DEFine? 1 %(1,1,0.00,0.00,(1,2,1.00,1.00,[0.30,1.00],[0.70,1.00]))
:DISPlay:LAYout:DEFine? 2 %(1,1,0.00,0.00,(2,1,1.00,1.00,[1.00,0.50],[1.00,0.50]))
```

### // Join the 2 layouts, display the nested layout

```
:DISPlay:LAYout:JOIN 1,2,2
:DISPlay:LAYout:APPLy 1
```

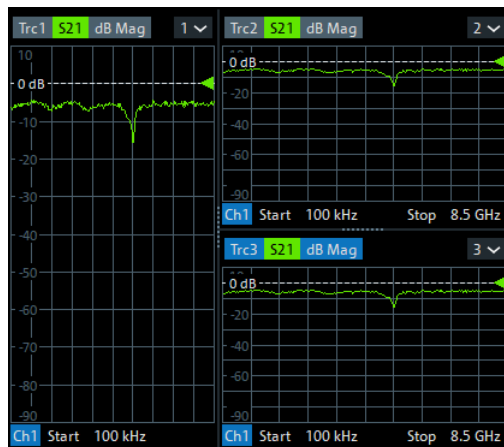

### // Check the last applied (i.e. the joined) layout for the correct format

```
:DISPlay:LAYout:EXECute?
 %(1,1,0.00,0.00,(1,2,1.00,1.00,[0.30,1.00],
 %(1,1,0.70,1.00,(2,1,1.00,1.00,[1.00,0.50],[1.00,0.50]))))
```

### // Set the layout format directly (horizontal, joined layout)

```
:DISPlay:LAYout:EXECute
 '(1,1,0.00,0.00,(1,2,1.00,1.00,[0.30,1.00],
 (1,1,0.70,1.00,(2,1,1.00,1.00,[1.00,0.50],[1.00,0.50])))'
```

**// Alternative direct definition of the joined layout as a vertical layout**

```
:DISPlay:LAYout:DEFine 3, VERT, '0.3,1.0;0.7,0.5,0.5'
:DISPlay:LAYout:APPLy 3
:DISPlay:LAYout:EXECute?
 %(1,2,0.00,0.00,(1,1,0.3,1.00,[1.00,1.0]),(2,1,0.7,1.00,[1.00,0.5],[1.00,0.5]))
```

**9.2.3 Using Markers**

The following example shows you how to define markers and use them to read trace values.

**// Reset the analyzer**

```
*RST
:SYSTEM:DISPLAY:UPDATE ON
```

**// Initiate a single sweep**

```
:INITiate1:CONTinuous OFF
:INITiate1:IMMediate;*WAI

// The following marker commands have the channel no. as a numeric suffix.
// The parameter belongs to a trace, the assignment channel -> trace
// is done via a "active" trace for each channel
:CALCULATE1:PARAMETER:SELECT 'Trc1'
```

**// Marker ON / OFF**

```
:CALCULATE1:MARKER1 ON
:CALCULATE1:MARKER1:STATE?
```

**// Coupled Markers**

```
// All markers belonging to channels with the same sweep type
// (FREQUENCY, TIME, POWER, CW FREQUENCY) are coupled/decoupled
:CALCULATE1:MARKER:COUPLED ON
```

**// Marker Continuous / Discrete**

```
:CALCULATE1:MARKER1:MODE CONTINUOUS
```

**// Normal / Delta / Reference / Fixed Marker**

```
:CALCULATE1:MARKER:AOFF // all markers off
:CALCULATE1:MARKER1 ON
:CALCULATE1:MARKER1:X 1GHZ
:CALCULATE1:MARKER2 ON
:CALCULATE1:MARKER2:X 2GHZ
:CALCULATE1:MARKER3 ON
:CALCULATE1:MARKER3:X 3GHZ
:CALCULATE1:MARKER4:DELTA:STATE ON
```

```
:CALCULATE1:MARKER:REFERENCE ON
:CALCULATE1:MARKER:REFERENCE:X 5GHZ
:CALCULATE1:MARKER1:TYPE FIXED
```

### // Query marker response values

```
:CALCULATE1:FORMAT MLINEAR
:CALCULATE1:MARKER1 ON
:CALCULATE1:MARKER1:X DEF
:CALCULATE1:MARKER1:FORMAT MLINEAR
// DataBase EMarkerFormat::LIN_MAG
:CALCULATE1:MARKER1:Y?
:CALCULATE1:MARKER1:FORMAT MLOGARITHMIC
// DB_MAG
:CALCULATE1:MARKER1:Y?
```

## 9.2.3.1 Marker Search Functions

The following example shows how to search for particular measurement points using markers.

### // Reset the analyzer

```
*RST
:SYSTEM:DISPLAY:UPDATE ON
```

### // Define marker and stimulus range

```
:CALCULATE1:MARKER1 ON
:SENSE1:FREQUENCY:START 1GHZ
:SENSE1:FREQUENCY:STOP 2GHZ
// Do the marker search in the format DB Magnitude
:CALCULATE1:FORMAT MLOGARITHMIC
```

### // Define marker search ranges (stimulus range of the marker search)

```
// Range 0 is always the stimulus range of the trace (can't be changed)
:CALCULATE1:MARKER1:FUNCTION:DOMAIN:USER 0
:CALCULATE1:MARKER1:FUNCTION:DOMAIN:USER:START?
:CALCULATE1:MARKER1:FUNCTION:DOMAIN:USER:STOP?

// Range 1 (within the stimulus range)
:CALCULATE1:MARKER1:FUNCTION:DOMAIN:USER 1
:CALCULATE1:MARKER1:FUNCTION:DOMAIN:USER:START 1.2GHZ
:CALCULATE1:MARKER1:FUNCTION:DOMAIN:USER:STOP 1.8GHZ

// Range 2 (includes the stimulus range)
:CALCULATE1:MARKER1:FUNCTION:DOMAIN:USER 2
:CALCULATE1:MARKER1:FUNCTION:DOMAIN:USER:START 0.8GHZ
:CALCULATE1:MARKER1:FUNCTION:DOMAIN:USER:STOP 2.2GHZ
```

```

// Use range 0 (stimulus range of the trace)
:CALCULATE1:MARKER1:FUNCTION:DOMAIN:USER 0

// Select linear magnitude scale for diagram

:CALCULATE1:FORMAT MLINEAR

// Search for global minimum and maximum (MIN, MAX)

// (initial marker value may be inside or outside the marker search range)
:CALCULATE1:MARKER1:X 1.5GHZ
:CALCULATE1:MARKER:MIN
:CALCULATE1:MARKER1:X?

:CALCULATE1:MARKER1:X 1.5GHZ
:CALCULATE1:MARKER:MAX
:CALCULATE1:MARKER1:X?

// Minimum peak search functions

:CALCULATE1:MARKER1:FUNCTION:SELECT MINIMUM
:CALCULATE1:MARKER1:FUNCTION:SELECT?
// NEXT PEAK
:CALCULATE1:MARKER1:X 1.5GHZ
:CALCULATE1:MARKER:SEARCH:NEXT
:CALCULATE1:MARKER1:X?
// PEAK RIGHT
:CALCULATE1:MARKER1:X 1.5GHZ
:CALCULATE1:MARKER:SEARCH:RIGHT
:CALCULATE1:MARKER1:X?
// PEAK LEFT
:CALCULATE1:MARKER1:X 1.5GHZ
:CALCULATE1:MARKER:SEARCH:LEFT
:CALCULATE1:MARKER1:X?

// Maximum peak search functions

:CALCULATE1:MARKER1:FUNCTION:SELECT MAXIMUM
// Proceed as for minimum search

```

## 9.2.4 Data Handling

The following sections provide examples for efficient sweep definition and data handling. Part of the functionality is not available in manual control.

### 9.2.4.1 Single Sweep Mode

The commands `CALCulate<Ch>:DATA:NSweep...? SDATa,` `<Trace_Hist_Count>` retrieve the results of any sweep within a previously defined single sweep group. This means that, in single sweep mode, you can first measure a

specified number of sweeps (`SENSe<Ch>:SWEEp:COUNT <sweeps>`) and then read any of the data traces acquired.

This feature has no equivalent in manual control where always the last data trace is displayed.

```
// Reset the analyzer
*RST
:SYSTEM:DISPLAY:UPDATE ON

// Create a second and third channel with new diagrams and traces.
:CALCULATE2:PARAMETER:SDEFINE "Trc2","S11"
:CALCULATE2:PARAMETER:SELECT "Trc2"
:DISPLAY:WINDOW2:STATE ON
:DISPLAY:WINDOW2:TRACE1:FEED 'Trc2'

:CALCULATE3:PARAMETER:SDEFINE "Trc3","S11"
:CALCULATE3:PARAMETER:SELECT "Trc3"
:DISPLAY:WINDOW3:STATE ON
:DISPLAY:WINDOW3:TRACE1:FEED 'Trc3'

// Select sweep time for the channels.
:SENSE1:SWEEP:TIME 1 S
:SENSE2:SWEEP:TIME 1 S
:SENSE3:SWEEP:TIME 1 S

// Enable single sweep mode for all channels so that channel-specific
// sweep count settings are used
:INITIATE:CONTINUOUS:ALL OFF

// Select single swep mode with channel-specific sweep count settings
// Set sweep counts and start measurement in all channels

:SENSE1:SWEEP:COUNT 1
:SENSE2:SWEEP:COUNT 2
:SENSE3:SWEEP:COUNT 3

:INITIATE1:IMMEDIATE; *WAI
:INITIATE2:IMMEDIATE; *WAI
:INITIATE3:IMMEDIATE; *WAI

// Select single swep mode with global sweep count settings

:SENSE:SWEEP:COUNT:ALL 2

:INITIATE1:IMMEDIATE; *WAI
:INITIATE2:IMMEDIATE; *WAI
:INITIATE3:IMMEDIATE; *WAI
```

#### 9.2.4.2 Modeling a Max Hold Function

The following example shows you how to emulate a max hold function.



**// Reset the analyzer**

```
*RST
:SYSTEM:DISPLAY:UPDATE ON
```

**// Create a trace with the last extremum as memory trace.**

```
:TRACe:COPI 'LastExtr', 'Trc1'

// Display this last extremum trace.
// Because it's a memory trace it must be displayed in the same diagram
// as the mother trace.
:DISPlay:WINDow1:TRACe2:FEED 'LastExtr'
:CALCulatel:MATH:SDEFine 'Max (Data, Mem)'
:CALCulatel:MATH:STATE ON
```

**// Single sweep mode**

```
:INITIATE:CONTINUOUS OFF

// Do a single sweep and update trace with the current extremum.
// This is the last extremum for the next sweep
:INITIATE:IMMEDIATE; *WAI
:TRACe:COPI:MATH 'LastExtr', 'Trc1'

// Loop over these 2 commands
:INITIATE:IMMEDIATE; *WAI
:TRACe:COPI:MATH 'LastExtr', 'Trc1'
:INITIATE:IMMEDIATE; *WAI
:TRACe:COPI:MATH 'LastExtr', 'Trc1'
```

**// Continuous sweep mode**

```
:INITIATE:CONTINUOUS ON
```

**9.2.4.3 Retrieving the Results of Previous Sweeps**

The commands `CALCulate<Ch>:DATA:NSweep...? SDATA,` `<Trace_Hist_Count>` retrieve the results of any sweep within a previously defined single sweep group. This means that, in single sweep mode, you can first measure a specified number of sweeps (`SENSe<Ch>:SWEep:COUNT <sweeps>`) and then read any of the data traces acquired.

This feature has no equivalent in manual control where always the last data trace is displayed.

**// Reset the analyzer**

```
*RST
:SYSTEM:DISPLAY:UPDATE ON
```

**// Create a second channel with a second trace**

```
:CALCULATE2:PARAMETER:SDEFINE "Trc2","S11"
:CALCULATE2:PARAMETER:SELECT "Trc2"
:DISPLAY:WINDOW2:STATE ON
:DISPLAY:WINDOW2:TRACE1:FEED 'Trc2'
```

**// Select active trace for the created channel 2. Adjust the number of sweep points.**

```
:CALCULATE2:PARAMETER:SELECT "Trc2"
:SENSE1:SWEEP:POINTS 3
:SENSE2:SWEEP:POINTS 4
```

**// Set sweep time and sweep count for the channels**

(3 traces per single sweep in channel 1, 4 traces in channel 2)

```
:SENSE1:SWEEP:TIME 1 S
:SENSE2:SWEEP:TIME 1 S
:SENSE1:SWEEP:COUNT 3
:SENSE2:SWEEP:COUNT 4
```

**// 1st Alternative: Reverse reading with command synchronization**

Select single sweep mode and measure a single sweep group for channels no. 1 and 2

```
:INITIATE:CONTinuous:ALL OFF
:INITIATE:IMMEDIATE:ALL; *WAI
```

Read trace data (without history, i.e. the last trace acquired in each channel)

```
:CALCULATE1:DATA? SDATA
:CALCULATE2:DATA? SDATA
```

Read last and previous trace data in channels 1 and 2

```
:CALCULATE1:DATA:NSWEEP? SDATA, 1 // last trace data
:CALCULATE1:DATA:NSWEEP? SDATA, 3 // previous trace data
:CALCULATE2:DATA:NSWEEP? SDATA, 1 // last trace data
:CALCULATE2:DATA:NSWEEP? SDATA, 4 // previous trace data
```

**// 2nd Alternative: Forward reading (no command synchronization necessary)**

Select single sweep mode and measure a single sweep group for channels no. 1

```
:INITIATE1:CONTinuous OFF
:INITIATE1:IMMEDIATE
```

Read the first and the following trace data in channel 1

```
if (CALCULATE1:DATA:NSWEEP:COUNT? > 2)
:CALCULATE1:DATA:NSWEEP:FIRST? SDATA, 1 // first trace data
:CALCULATE1:DATA:NSWEEP:FIRST? SDATA, 3 // third trace data
```

#### 9.2.4.4 Exporting S-Parameters

The calibration defines which S-Parameters are allowed to be exported to a Touchstone file. In the following example, a default (TOSM) calibration is created to make all S-Parameters available.

##### // Reset the analyzer

```
*RST
:SYSTEM:DISPLAY:UPDATE ON

:SENSE1:CORRECTION:COLLECT:METHOD:DEFINE 'Test', TOSM, 1, 2, 3, 4
:SENSE1:CORRECTION:COLLECT:SAVE:SELECTED:DEFAULT
```

##### // Initiate a complete sweep

```
:INITIATE1:CONTINUOUS OFF; :INITIATE:IMMEDIATE;*WAI
:MEMORY:STORE:TRACE:PORTS 1, 'ParserTouchstonePorts.s1p', COMPLEX, 2
:MEMORY:STORE:TRACE:PORTS 1, 'ParserTouchstonePorts.s2p', COMPLEX, 3, 2
:MEMORY:STORE:TRACE:PORTS 1, 'ParserTouchstonePorts.s4p', COMPLEX, 1, 4, 3, 2
```

### 9.2.5 Calibration

The following programming examples are related to system error correction and power calibration.

#### 9.2.5.1 One and Two-Port Calibration

The following example calibrates one or two analyzer ports.

##### // Reset the analyzer

```
*RST
:SYSTEM:DISPLAY:UPDATE ON
```

##### // Set cal kit as active kit for N50

```
:SENSE:CORRECTION:CKIT:N50:SELECT 'ZV-Z121'
```

##### // Select connectors for the ports

```
:SENSE1:CORRECTION:COLLECT:CONNECTION1 N50MALE
:SENSE1:CORRECTION:COLLECT:CONNECTION2 N50MALE

// Don't save the cal standard measurements with apply cal, i.e. with the commands
// :SENSE1:CORRECTION:COLLECT:SAVE or
// :SENSE1:CORRECTION:COLLECT:SAVE:SELECTED
// Instead, use the global, channel-independent setting:
:SENSE:CORRECTION:COLLECT:ACQUIRE:SAVE:DEFAULT OFF
```

**// Full one port = OSM**

```
// Select cal procedure
:SENSe1:CORRection:COLLect:MEthod:DEFine 'Test SFK OSM 1', FOPORT, 1

// Measure Standards
:SENSe1:CORRection:COLLect:ACQuire:SELected OPEN, 1
:SENSe1:CORRection:COLLect:ACQuire:SELected SHORT, 1
:SENSe1:CORRection:COLLect:ACQuire:SELected MATCH, 1

// Apply cal
:SENSe1:CORRection:COLLect:SAVE:SELected
```

**// 2 port TOSM**

```
// Select cal procedure
:SENSe1:CORRection:COLLect:MEthod:DEFine 'Test SFK TOSM 12', TOSM, 1, 2

// Measure Standards
:SENSe1:CORRection:COLLect:ACQuire:SELected THROUGH, 1, 2
:SENSe1:CORRection:COLLect:ACQuire:SELected OPEN, 1
:SENSe1:CORRection:COLLect:ACQuire:SELected SHORT, 1
:SENSe1:CORRection:COLLect:ACQuire:SELected MATCH, 1
:SENSe1:CORRection:COLLect:ACQuire:SELected OPEN, 2
:SENSe1:CORRection:COLLect:ACQuire:SELected SHORT, 2
:SENSe1:CORRection:COLLect:ACQuire:SELected MATCH, 2

// Apply calibration
:SENSe1:CORRection:COLLect:SAVE:SELected
```

**// Save / load cal files**

```
// Save calibration in calibration file pool
```

**// the filename in the commands must not contain the path !**

```
:MMEMORY:STORE:CORRection 1, 'OSM1 TOSM12.cal'

// load cal file from calibration file pool
:MMEMORY:LOAD:CORRection 1, 'OSM1 TOSM12.cal'
```

**9.2.5.2 MultiCal (with Calibration Unit)**

The following example demonstrates how to create multiple system error corrections on the same channel.

**// Reset the analyzer**

```
*RST
```

```
////////////////////////////////////
```

**// Connect to the cal unit**

```
:SYSTem:COMMunicate:RDEvice:AKAL:ADDRess 'ZN-Z51::999002'
```

```
//
```

**// Prepare the multi cal**

```
// create the first calibration:
// with full multi port and factory calkit
:SENSE1:CORREction:COLLECT:AUTO:CONFigure FNPort, ''
// the first cal addresses test ports 2,3 and 4 and explicitly
// assigns them to cal unit ports 2,3 and 4, respectively
:SENSE1:CORREction:COLLECT:AUTO:ASSignment1:DEFine 2,2,3,3,4,4
// get the number of port assignments of the current calibration
// expected result: 1
:SENSE1:CORREction:COLLECT:AUTO:ASSignment:COUNT?
// explore port assignment 1
// expected result: 2,2,3,3,4,4
:SENSE1:CORREction:COLLECT:AUTO:ASSignment1:DEFine?
// create the second calibration:
// full one port and factory calkit
:SENSE1:CORREction:COLLECT:AUTO:CONFigure FOPort, ''
// the second cal addresses test port 1
// and explicitly assigns it to cal unit port 1
:SENSE1:CORREction:COLLECT:AUTO:ASSignment2:DEFine 1,1
// get the number of port assignments of the current calibration
// expected result: 1
:SENSE1:CORREction:COLLECT:AUTO:ASSignment:COUNT?
// get the number of port assignments of all calibrations
// expected result: 2
:SENSE1:CORREction:COLLECT:AUTO:ASSignment:ALL:COUNT?
// explore port assignment 2
// expected result: 1,1
:SENSE1:CORREction:COLLECT:AUTO:ASSignment2:DEFine?
```

```
//
```

**// Acquire error correction data**

```
:SENSE1:CORREction:COLLECT:AUTO:ASSignment1:ACQUire
:SENSE1:CORREction:COLLECT:AUTO:ASSignment2:ACQUire
```

```
//
```

**// Save the complete Multi-Cal**

```
:SENSE1:CORREction:COLLECT:AUTO:SAVE
```

```
//
```

### 9.2.5.3 Saving and Recalling Error Terms

The following examples show you how to perform a system error correction, save the acquired system error correction data to a file and reload them.

#### Performing a Calibration, Saving the Error Terms

##### // Reset the analyzer

```
*RST
:SYSTEM:DISPLAY:UPDATE ON
```

##### // Set frequency range

```
:SENSE1:FREQUENCY1:START 1GHz
:SENSE1:FREQUENCY1:STOP 4GHz
:SENSE1:SWEPT:POINTS 6
```

##### // Select calibration type: TOSM at ports 1 and 2

```
:SENSE1:CORRECTION:COLLECT:METHOD:DEFINE 'Test SFK TOSM 12', TOSM, 1, 2

// Measure Standards
:SENSE1:CORRECTION:COLLECT:ACQUIRE:SELECTED THROUGH, 1, 2
:SENSE1:CORRECTION:COLLECT:ACQUIRE:SELECTED OPEN, 1
:SENSE1:CORRECTION:COLLECT:ACQUIRE:SELECTED SHORT, 1
:SENSE1:CORRECTION:COLLECT:ACQUIRE:SELECTED MATCH, 1
:SENSE1:CORRECTION:COLLECT:ACQUIRE:SELECTED OPEN, 2
:SENSE1:CORRECTION:COLLECT:ACQUIRE:SELECTED SHORT, 2
:SENSE1:CORRECTION:COLLECT:ACQUIRE:SELECTED MATCH, 2
```

##### // Apply calibration

```
SENSE1:CORRECTION:COLLECT:SAVE:SELECTED
```

##### // Save error terms

```
:FORMAT REAL, 32
@TRACEFILE:scorr1.dat
:CALCULATE1:DATA? SCORr1
@TRACEFILE:scorr2.dat
:CALCULATE1:DATA? SCORr2
@TRACEFILE:scorr3.dat
:CALCULATE1:DATA? SCORr3
// We are omitting the isolation term, as it is not implemented
// @TRACEFILE:scorr4.dat
// :CALCULATE1:DATA? SCORr4
@TRACEFILE:scorr5.dat
:CALCULATE1:DATA? SCORr5
@TRACEFILE:scorr6.dat
:CALCULATE1:DATA? SCORr6
@TRACEFILE:scorr7.dat
```

```

:CALCulate1:DATA? SCORr7
@TRACEFILE:scorr8.dat
:CALCulate1:DATA? SCORr8
@TRACEFILE:scorr9.dat
:CALCulate1:DATA? SCORr9
// We are omitting the isolation term, as it is not implemented
// @TRACEFILE:scorr10.dat
// :CALCulate1:DATA? SCORr10
@TRACEFILE:scorr11.dat
:CALCulate1:DATA? SCORr11
@TRACEFILE:scorr12.dat
:CALCulate1:DATA? SCORr1

```

## Performing a New Calibration, Recalling the Error Terms

### // Reset the analyzer

```
*RST
```

### // Set frequency range

```

:SENSe1:FREQuency1:STARt 1GHz
:SENSe1:FREQuency1:STOP 4GHz
:SENSe1:SWEep:POINts 6

```

### // Select calibration type: TOSM at ports 1 and 2

```
:SENSe1:CORRection:COLlect:MEthod:DEFine 'XYZ', TOSM, 1, 2
```

### // Generate a set of default correction data, switch on user calibration

```

:SENSe1:CORRection:COLlect:SAVE:SElected:DEFault
SENSE1:CORRECTION:STATE ON

// In the previous section, the following error terms were saved:
// SCORR1 Forward Directivity
// SCORR2 Forward Source Match
// SCORR3 Forward Reflection Tracking
// SCORR4 Forward Isolation
// SCORR5 Forward Load Match
// SCORR6 Forward Transmission Tracking
// SCORR7 Reverse Directivity
// SCORR8 Reverse Source Match
// SCORR9 Reverse Reflection Tracking
// SCORR10 Reverse Isolation
// SCORR11 Reverse Load Match
// SCORR12 Reverse Transmission Tracking

// Equivalences between the first parameter of CALCulate:DATA
// and the first 3 Parameters of SENSe:CORRection:CDAta

```

```
// 'SCORR1' 'DIRECTIVITY', 1, 0 <Port 2> = 0 ignored
// 'SCORR2' 'SRCMATCH', 1, 0 <Port 2> = 0 ignored
// 'SCORR3' 'REFLTRACK', 1, 0 <Port 2> = 0 ignored
// 'SCORR4' 'ISOLATION', 1, 2
// 'SCORR5' 'LOADMATCH', 1, 2
// 'SCORR6' 'TRANSTRACK', 1, 2
// 'SCORR7' 'DIRECTIVITY', 2, 0 <Port 2> = 0 ignored
// 'SCORR8' 'SRCMATCH', 2, 0 <Port 2> = 0 ignored
// 'SCORR9' 'REFLTRACK', 2, 0 <Port 2> = 0 ignored
// 'SCORR10' 'ISOLATION', 2, 1
// 'SCORR11' 'LOADMATCH', 2, 1
// 'SCORR12' 'TRANSTRACK', 2, 1
```

### // Set format for data transfer

```
:FORMAT REAL,32
```

### // !!! Important !!! Stop sweep when loading error terms

```
:INITiate:CONTinuous OFF
```

### // Recall error terms

```
// CALCulate:DATA is suitable for 2-port terms;
// use SENSE:CORRection:CDATA for more than 2 ports
:CALCulate1:DATA SCORR1,#@scorr1.dat
:CALCulate1:DATA SCORR2,#@scorr2.dat
:CALCulate1:DATA SCORR3,#@scorr3.dat
// We are omitting the isolation term, as it is not implemented on the ZVAB
//:CALCulate1:DATA SCORR4,#@scorr4.dat
:CALCulate1:DATA SCORR5,#@scorr5.dat
:CALCulate1:DATA SCORR6,#@scorr6.dat
:CALCulate1:DATA SCORR7,#@scorr7.dat
:CALCulate1:DATA SCORR8,#@scorr8.dat
:CALCulate1:DATA SCORR9,#@scorr9.dat
// We are omitting the isolation term, as it is not implemented on the ZVAB
//:CALCulate1:DATA SCORR10,#@scorr10.dat
:CALCulate1:DATA SCORR11,#@scorr11.dat
:CALCulate1:DATA SCORR12,#@scorr12.dat

:INITiate:CONTinuous ON
```

### Using a Calibration Data Recorded Previously

You can reuse any set of correction data that you acquired in earlier sessions on your analyzer. In general you have to carry out the following steps:

1. Create a dummy correction data set and store it to a file.
2. Replace the dummy data with your correction data.
3. Reimport the correction data file and apply it to a channel.



See also the program examples for the following commands:

- [SENSE<Ch>:]CORREction:COLlect:SAVE:SElected:DEFault (dummy system error correction)
- SOURCE<Ch>:POWER<Pt>:CORREction:DEFault (dummy source power calibration without external power meter)

#### 9.2.5.4 Adapter Removal

##### // define calibration method

```
SENSE1:CORREction:COLlect:METHOD:DEFine 'Parser Test SFK', ARTosm, 1, 2
```

##### // Start with Calkit-1 (e.g. 3.5 mm ideal Kit)

```
//adapter side port 1
SENSE1:CORRECTION:COLLECT:ACQUIRE:SElected OPEN, 1, ON
SENSE1:CORRECTION:COLLECT:ACQUIRE:SElected SHORT, 1, ON
SENSE1:CORRECTION:COLLECT:ACQUIRE:SElected MATCH, 1, ON
```

```
//non adapter side port 2
SENSE1:CORRECTION:COLLECT:ACQUIRE:SElected OPEN, 2, OFF
SENSE1:CORRECTION:COLLECT:ACQUIRE:SElected SHORT, 2, OFF
SENSE1:CORRECTION:COLLECT:ACQUIRE:SElected MATCH, 2, OFF
```

##### // continue with Calkit-1 (e.g. N 50 Ohm ideal Kit)

```
//adapter side port 2
SENSE1:CORRECTION:COLLECT:ACQUIRE:SElected OPEN, 2, ON
SENSE1:CORRECTION:COLLECT:ACQUIRE:SElected SHORT, 2, ON
SENSE1:CORRECTION:COLLECT:ACQUIRE:SElected MATCH, 2, ON
```

```
//non adapter side port 1
SENSE1:CORRECTION:COLLECT:ACQUIRE:SElected OPEN, 1, OFF
SENSE1:CORRECTION:COLLECT:ACQUIRE:SElected SHORT, 1, OFF
SENSE1:CORRECTION:COLLECT:ACQUIRE:SElected MATCH, 1, OFF
```

##### // connect adapter between port 1 and 2

```
SENSE1:CORRECTION:COLLECT:ACQUIRE:SElected THROUGH, 1, 2
```

##### // save calibration

```
SENSE1:CORREction:COLlect:SAVE:SElected
```

#### 9.2.6 Fixture Modeling

We create and apply a fixture model for single-ended deembedding at ports 1 and 2 using the ISD tool.

**Prepare the channel**

```
*RST
:SENSe1:FREQuency:START MINimum
:SENSe1:FREQuency:STOP MAXimum
```

**Perform a full two-port calibration at ports 1 and 2**

For an example, see "[// 2 port TOSM](#)" on page 1136

**Measure the test coupon**

We are using a single-ended (2-port) "Symmetric 2x Thru" coupon (balanced). Connect it to ports 1 and 2.

```
:CALCulate:FMODEl:ISD1:COUPon:TYPE SYMMetric2x
:CALCulate:FMODEl:ISD1:COUPon:STATe 1
:CALCulate:FMODEl:ISD2:COUPon:STATe 1
:CALCulate:FMODEl:ISD3:COUPon:STATe 0
:CALCulate:FMODEl:ISD4:COUPon:STATe 0
:CALCulate:FMODEl:ISD:COUPon:MEASure
```

**Measure the DUT together with the test fixture**

Connect DUT + test fixture to ports 1 and 2.

```
:CALCulate:FMODEl:ISD1:DUT:STATe 1
:CALCulate:FMODEl:ISD2:DUT:STATe 1
:CALCulate:FMODEl:ISD3:DUT:STATe 0
:CALCulate:FMODEl:ISD4:DUT:STATe 0
:CALCulate:FMODEl:ISD1:DUT:MEASure
:CALCulate:FMODEl:ISD1:RUN:STATe 1
:CALCulate:FMODEl:ISD2:RUN:STATe 1
:CALCulate:FMODEl:ISD3:RUN:STATe 0
:CALCulate:FMODEl:ISD4:RUN:STATe 0
:CALCulate:FMODEl:ISD:RUN:RUN
```

**Measure the DUT together with the test fixture**

Run the ISD tool and apply the generated s2p files to port 1 (unswapped) and port 2 (swapped).

```
:CALCulate:FMODEl:ISD1:RUN:STATe 1
:CALCulate:FMODEl:ISD2:RUN:STATe 1
:CALCulate:FMODEl:ISD3:RUN:STATe 0
:CALCulate:FMODEl:ISD4:RUN:STATe 0
:CALCulate:FMODEl:ISD:RUN:RUN
```

# 10 Error Messages and Troubleshooting

## 10.1 Errors during Firmware Operation

An error generally causes the analyzer to display a tooltip across the lower part of the screen. The tooltip provides a textual description of the error, e.g.:

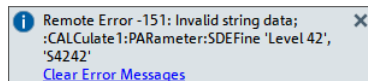

The errors can be divided into four categories:

- Remote errors (SCPI errors) can occur during the execution of a remote control program. They include an error code, followed by the short description of the error. Remote errors are specified and described in the SCPI standard; they are cleared upon \*CLS.
- Software errors (setting errors) can occur, e.g., if numeric entries in an analyzer dialog are incompatible with each other or with the current analyzer state. These errors are self-explanatory and easy to correct.
- Hardware errors indicate an incorrect hardware state. Some of the hardware errors cause the instrument to be switched off to avoid damage. Hardware errors with possible causes and remedies are listed in the following sections.
- Exceptions indicate anomalous or exceptional events that were not properly handled by the R&S ZND firmware.



### Troubleshooting SCPI errors

A misspelled command header causes SCPI error -113, "Undefined header;..."; a misspelled parameter causes SCPI error -141, "Invalid character data;...". The GPIB explorer provides a list of all supported commands and their character data parameters; see [Chapter 7.1.2, "GPIB Explorer"](#), on page 560.

### Hardware error categories

Hardware errors can be detected at various stages of the start-up or measurement procedure.

- Configuration errors occur on start-up of the analyzer, e.g. if a hardware module or configuration file cannot be detected. Configuration errors cause an entry in the error log (SYSTEM > [SETUP] > "Setup" > "Info" > "Error Log").
- Asynchronous errors can occur any time while the analyzer is operating. The analyzer is checked periodically for asynchronous errors.
- Measurement errors are due to inadmissible hardware settings and states during the measurement process.

### 10.1.1 Asynchronous Errors

Asynchronous errors can occur any time while the analyzer is operating. The analyzer is checked periodically for asynchronous errors. Many of these errors also cause an entry in the status reporting system.

| Error                                  | Description                                                                                                                                                                                                                                                                                                                                                                                                                                                                         | Remedy                                                                              | Bit no.*) |
|----------------------------------------|-------------------------------------------------------------------------------------------------------------------------------------------------------------------------------------------------------------------------------------------------------------------------------------------------------------------------------------------------------------------------------------------------------------------------------------------------------------------------------------|-------------------------------------------------------------------------------------|-----------|
| Instrument temperature is too high     | The analyzer detects that the instrument temperature is too high. After three warnings, the analyzer is shut down.                                                                                                                                                                                                                                                                                                                                                                  | Reduce ambient temperature, keep ventilation holes of the casing unobstructed.      | 7         |
| Receiver overload protection tripped   | The analyzer detects an excessive input level at one of the ports.<br><br>If this condition persists, all internal and external generators are switched off ("RF Off").                                                                                                                                                                                                                                                                                                             | Reduce RF input level at the port. Check amplifiers in the external test setup.     | 3         |
| Reference frequency lock failure       | With external reference signal (System – External Reference active) or internal high precision clock, the reference oscillator is phase locked to a 10 MHz signal. The message appears when this phase locked loop (PLL) fails.                                                                                                                                                                                                                                                     | For external reference: check frequency and level of the supplied reference signal. | 1         |
| Converter clock frequency lock failure | The clock generator for the AD converter clock is phase locked to the reference oscillator. The message appears when this PLL fails.                                                                                                                                                                                                                                                                                                                                                | –                                                                                   | –         |
| Oven cold                              | With OXCO option-B4, the oven temperature is too low.                                                                                                                                                                                                                                                                                                                                                                                                                               | Wait until the oven has been heated up                                              | 8         |
| Internal communication error           | A severe unexpected disturbance was observed (e.g. due to ESD ).<br><br>The firmware resets all hardware components to ensure proper instrument functioning and restores the user settings to the state before the event.<br><br>Finally, it indicates the foregone hardware reset by an information popup "Hardware communication problem detected. Hardware was reset. Measurement data of this sweep may be incorrect. Please contact Rohde & Schwarz if this problem persists." | If this error is raised repeatedly, please contact Rohde & Schwarz service.         | 6         |

\*) The following bits in the "[STATus:QUEStionable:INTegrity:HARDware](#)" on page 588 register are set when the error occurs.

### 10.1.2 Errors during Measurement

The following errors are due to inadmissible hardware settings and states during the measurement process. Some of the errors also cause an entry in the status reporting system.

| Error                                           | Description                                                                                                                                                                       | Remedy                                                                                                                                                                              | Bit no.*) |
|-------------------------------------------------|-----------------------------------------------------------------------------------------------------------------------------------------------------------------------------------|-------------------------------------------------------------------------------------------------------------------------------------------------------------------------------------|-----------|
| Unstable level control at port <i>              | The analyzer detects an excessive source level at one of the ports. The signal is turned off and the sweep halted.                                                                | Check signal path for the wave a <sub>i</sub> , especially check external components. Then press "Channel > Sweep > Sweep Control > Restart Sweep".                                 | 9         |
| Problem concerning external power meter Pmet<i> | An external power meter has been configured, however, it cannot be controlled or provides error messages. If several power meters cause problems, the lowest number is indicated. | Check whether the power meter is properly connected and switched on. Check the GPIB address; exclude address conflicts when using several external power meters or other equipment. | 11        |
| Time grid too close                             | The sweep points for a time sweep are too close, the analyzer cannot process the measurement data until the next sweep point starts.                                              | Increase stop time, reduce no. of points, increase IF bandwidth. If possible reduce number of partial measurements, e.g. by restricting the number of ports measured.               | 12        |
| Port <i> output power unlevelled                | The level control is unsettled or unstable, possibly due to an external disturbing signal.                                                                                        | Change generator level at the port; check external components.                                                                                                                      | 2         |

\*) The following bits in the `STATUS:QUESTIONABLE:INTEGRITY:HARDWARE` register are set when the error occurs.

## 10.2 Errors during Firmware Installation/Update

During firmware installation or update, if the installer encounters an error, the update is canceled and the analyzer firmware is rolled back to its previous state.

Currently there is only one exception to this rule, which was implemented to recover gracefully from a failed FPGA update:

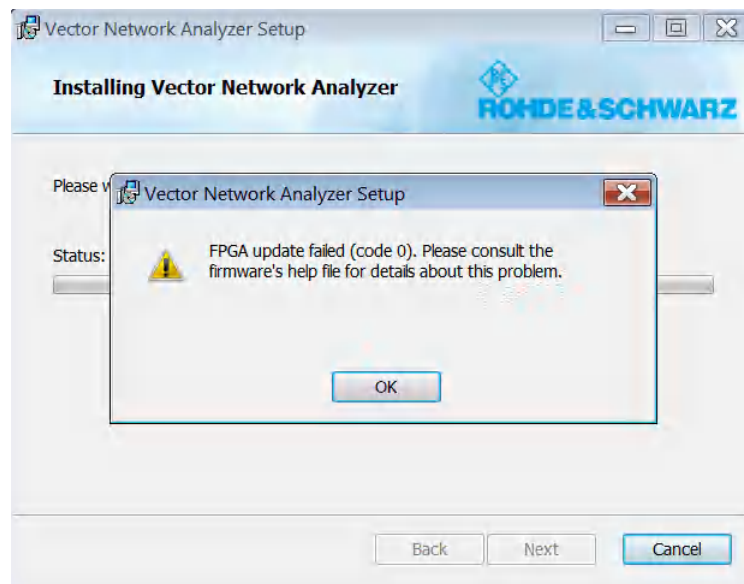

Figure 10-1: FPGA update failure

In this case, the installation proceeds but requires additional steps to be taken in order to perform the failed FPGA update manually.



No matter if the manual FPGA update described below is successful or not, write down the error code and contact our support.

1. Reboot the analyzer.
2. Exit the firmware.
3. Run the flash utility located at `C:\Program Files\Rohde-Schwarz\Vector Network Analyzer\ZNB\Bin\flash.exe`.

```

C:\Program Files\Rohde-Schwarz\Vector Network Analyzer\Bin\Flash.exe
ZNBC Flash Tool
=====
..Init..
..Load HwLayer..
..Detect Hardware..

Initialize Device Driver ...

Update of Flash memory. DO NOT SWITCH OFF. This might take up to 5 minutes
Writing Flash memory... _

```

4. Wait until the process has completed.
5. Turn off the analyzer (a reboot is not sufficient).

If successful, this procedure brings the analyzer back to working condition.

## 10.3 Collecting Information for Technical Support

If you encounter problems that you cannot solve yourself, contact your Rohde & Schwarz support center, see [Chapter 10.4, "Contacting Customer Support"](#), on page 1148. Our support center staff is optimally trained to assist you in solving problems.

The support center finds solutions more quickly and efficiently if you provide them with information on the instrument and an error description.

### Creating Windows Event Log Files

Windows records important actions of applications and the operating system in event logs. You can create event log files to summarize and save the existing event logs. You can send these files to Rohde & Schwarz if there is a problem with your device.

#### To create Windows event log files



1. Select the "Windows Start Button" in the bottom left corner.
2. Type in *Event Viewer* and select "Enter".

3. Select and expand "Windows Logs" in the "Console Tree".
4. Right-click on each subsection and select "Save All Events As...".

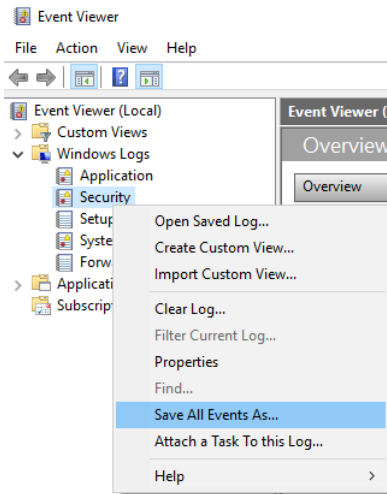

Figure 10-2: Event Viewer

5. Enter a file name and select "Save"

You can now send the Windows Event Log Files to Rohde & Schwarz.

### Obtaining information from the R&S ZND firmware

The instrument generates error messages which are usually sufficient for you to detect the cause of an error and find a remedy. Error message types are described in [Chapter 10, "Error Messages and Troubleshooting"](#), on page 1143.

In addition, the system **"Info" dialog** offers valuable troubleshooting information. This dialog can be opened via the "Info..." button in the SYSTEM – [SETUP] > "Setup" soft-tool tab.

For details on the available information, see [Chapter 6.17.1.3, "Info Dialog"](#), on page 533.

The required troubleshooting information can also be generated in the system "Info" dialog. **"Create R&S Support Information"** collects the following information:

- Setup, option, and hardware information, error log, and selftest results.  
This information can also be retrieved using the "Save..." function of the "Info" dialog.
- Current eeprom data.
- A screenshot of the VNA display.
- The latest 5 exception dumps.

The resulting \*.zip file is written to the report directory

C:\Users\Public\Documents\Rohde-Schwarz\Vna\Report. Its file name contains the current date and time, e.g. report\_20200228\_1658.zip.

## 10.4 Contacting Customer Support

### Technical support – where and when you need it

For quick, expert help with any Rohde & Schwarz product, contact our customer support center. A team of highly qualified engineers provides support and works with you to find a solution to your query on any aspect of the operation, programming or applications of Rohde & Schwarz products.

### Contact information

Contact our customer support center at [www.rohde-schwarz.com/support](http://www.rohde-schwarz.com/support), or follow this QR code:



*Figure 10-3: QR code to the Rohde & Schwarz support page*



# 11 Annexes

The following sections cover mostly hardware and service-related topics.

## 11.1 Administrative Tasks

This chapter describes some topics that are only needed occasionally, or if a special instrument configuration is required.

### 11.1.1 Windows Operating System

The analyzer is equipped with a Windows® operating system which has been configured according to the instrument's features and needs. Changes in the system configuration can be necessary to:

- Establish a LAN connection
- Customize the properties of the external accessories connected to the analyzer
- Call up additional software tools

---

#### **NOTICE**

##### **Modifications of the operating system**

The operating system is adapted to the network analyzer. To avoid impairment of instrument functions, only change the settings described in this manual. Existing software must be modified only with update software released by Rohde & Schwarz. Likewise, only programs authorized by Rohde & Schwarz for use on the instrument must be executed.

---

All necessary settings can be accessed from the Windows "Start" menu, in particular from the "Control Panel". To open the "Start" menu, press the Windows key in the toolbar or on an external keyboard.



##### **User accounts and password protection**

The analyzer uses a user name and password as credentials for remote access. Two user accounts with different levels of access are available on the instrument:

- "instrument" is the default account with standard rights to change system settings. Use this account for normal operation of the analyzer.
- "Admin" is the account for administering the operating system. This account is required, for instance, if you wish to install programs on the analyzer. [For instruments running Windows 7, this account is named "Administrator".]

In the factory configuration, "894129" is preset as a password for both users. To protect the analyzer from unauthorized access, it is recommended to change the preset passwords.

To switch from one user account to another, log off from Windows and then log on again. The "switch user" functionality is disabled on the R&S ZND.

### 11.1.2 Firmware Installation

Upgrade versions of the analyzer firmware are supplied as single executable setup files (\*.exe).



#### 64-bit only

Since version 3.00 of the analyzer firmware, 32-bit Windows is no longer supported. Only 64-bit firmware is available.

To upgrade your instrument to 64-bit Windows 10, contact Rohde & Schwarz service.



#### Admin account

You need administrator rights to install a new firmware. See note on "[User accounts and password protection](#)" on page 1149 for details.

To perform a firmware update:

1. Copy the setup file to any storage medium accessible from the analyzer. This can be either the internal mass storage drive, an external storage medium (USB memory stick, external CD-ROM drive) or a network connection (LAN).  
The default name of the internal drive is C:. External storage devices are automatically mapped to the next free drive, i.e. D:, E: etc.
2. Run the setup file from the Windows® Explorer. Follow the instructions of the setup wizard.  
Setup files can be reinstalled.



#### Factory calibration

A firmware update does not affect the factory calibration.



#### Downgrade to a firmware version < 3.00

To downgrade the firmware from a version  $\geq 3.00$  to a version  $< 3.00$ , it is required to uninstall the firmware using Windows 10 "Apps & features" (Windows 7 "Programs and Features") before proceeding with the installation.

### 11.1.3 Remote Operation in a LAN

A LAN connection is used to integrate the analyzer into a home/company network. LAN connectivity offers several applications, e.g.:

- Transfer data between a controller and the analyzer, e.g. to run a remote control program.

- Control the measurement from a remote computer using Remote Desktop or a similar application.
- Use external network devices (e.g. printers).

---

**NOTICE****Virus protection**

An efficient virus protection is a prerequisite for secure operation in the network. Never connect your analyzer to an unprotected network. For useful hints, see the following Rohde & Schwarz application note:

- [1EF96: Malware Protection Windows 10](#)
- Windows 7: [1DC01: Malware Protection Windows 7](#)

---

The analyzer uses a user name and password as credentials for remote access; see note on "[User accounts and password protection](#)" on page 1149 for details. To protect the analyzer from unauthorized access, it is recommended to change the factory setting.

### 11.1.3.1 Assigning an IP Address

Depending on the network capacities, the TCP/IP address information for the analyzer can be obtained in different ways.

- If the network supports dynamic TCP/IP configuration using the Dynamic Host Configuration Protocol (DHCP), all address information can be assigned automatically.
- If the network does not support DHCP, or if the analyzer is set to use alternate TCP/IP configuration, the addresses must be set manually.

By default, the analyzer is configured to use dynamic TCP/IP configuration and obtain all address information automatically. This means that it is safe to establish a physical connection to the LAN without any previous analyzer configuration.

---

**NOTICE****Manual TCP/IP configuration**

If your network does not support DHCP, or if you choose to disable dynamic TCP/IP configuration, you must assign valid address information **before** you connect the analyzer to the LAN. Contact your network administrator to obtain a valid IP address, because connection errors can affect the entire network.

---

**Admin account**

You need administrator rights to change the TCP/IP configuration. See note on "[User accounts and password protection](#)" on page 1149 for details.

### To enter the TCP/IP address information manually

1. Obtain the IP address and subnet mask for the analyzer and the IP address for the local default gateway from your network administrator. If necessary, also obtain the name of your DNS domain and the IP addresses of the DNS and WINS servers on your network.
2. Press the Windows key in the SYSTEM keypad or on an external keyboard to access Windows®.
3. Open the "Control Panel" > "Network and Sharing Center" > "Change adapter settings" dialog and right-click the local connection.  
Windows 7: open the "Control Panel" > "Network and Internet" > "Network and Sharing Center" > "Local Area Connection Status" dialog.
4. Select "Properties" and confirm the user account control message, depending on your current user account.
  - If your current account is an administrator account, select "Yes".
  - If your account is an account with standard user rights, enter the password of the administrator account and select "Yes".

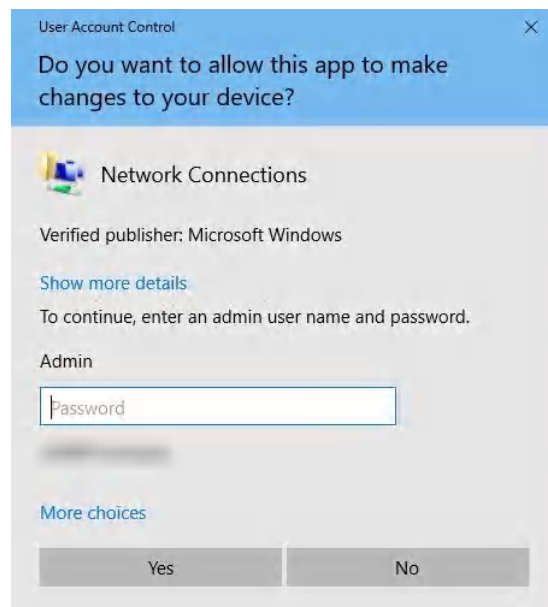

**Figure 11-1: User Account Control dialog**

5. In the "Connection Properties" dialog opened, select "Internet Protocol Version 4 (TCP/IPv4) > Properties" and enter the IP address information.

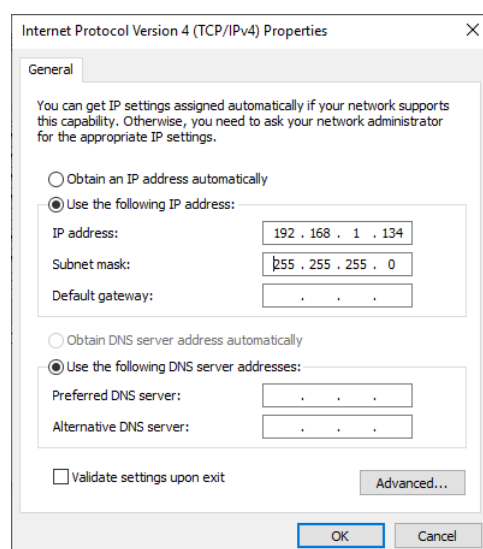

### 11.1.3.2 Using Computer Names

In a LAN that uses a DNS server (Domain Name System server), each PC or instrument connected in the LAN can be accessed via an unambiguous computer name instead of the IP address. The DNS server translates the host name to the IP address. This is especially useful when a DHCP server is used, as a new IP address may be assigned each time the instrument is restarted.

Each instrument is delivered with an assigned computer name, but this name can be changed. The default instrument name is a case-insensitive string with the following syntax:

ZND-<serial\_number>

The serial number can be found on the rear panel of the instrument. It is the third part of the device ID printed on the bar code sticker:



For example ZND-102030

### 11.1.3.3 Remote Desktop Connection

Remote Desktop is a Windows® application which you can use to access and control the analyzer from a remote computer through a LAN connection. While the measurement is running, the analyzer screen contents are displayed on the remote computer, and Remote Desktop provides access to all of the applications, files, and network resources of the analyzer.



At the R&S ZND by default remote connections are enabled using a local group policy and remote access is granted to users instrument and administrator.

For detailed information about Remote Desktop and the connection refer to the Windows® Help ("Windows Start Menu > Help and Support").

To establish a remote desktop connection, proceed as follows:

1. Connect remote Windows PC and VNA to the LAN and make sure that an IP connection can be established.
2. At the remote Windows PC, open a remote desktop connection (type "Remote Desktop Connection" at the Windows Start/Search menu and hit enter).
3. In the "Remote Desktop Connection" dialog, enter the VNA's computer name or IP address and select "Connect"

#### 11.1.3.4 Windows® Firewall Settings

A firewall protects an instrument by preventing unauthorized users from gaining access to it through a network. In the default configuration of the R&S ZND, the firewall is enabled. A remote desktop connection does not require any changes in the firewall settings.



##### Admin account

You need administrator rights to change the firewall settings. See note on "[User accounts and password protection](#)" on page 1149 above for details.

Some actions require a different firewall configuration, e.g.:

- To transfer data with other hosts in the LAN, you have to allow "File and Printer Sharing".

To change the firewall settings, proceed as follows:

1. Access the operating system by pressing the Windows® key on the external keyboard. Open the "Control Panel".
2. Select "Windows Defender Firewall"  
("System and Security > Windows Firewall" in Windows 7)
  - Select "Allow an app or feature through Windows Defender Firewall" to enable "File and Printer Sharing".  
(Windows 7: select "Change Settings > Allow a program or feature through Windows Firewall" to enable "File and Printer Sharing").
  - Select "Turn Windows Firewall on or off" to enable or disable the firewall.

You must confirm a user account control message to allow the desired changes (see [Figure 11-1](#)). For detailed information about the firewall refer to the Windows® Help.

**NOTICE****Risks of changing the firewall settings**

Disabling the firewall or allowing exceptions may make your instrument more vulnerable to viruses and intruders. It is recommended to restore the default firewall configuration after completing a task which requires modified settings.

## 11.2 System Recovery

**For instruments running Windows 10**, the system drive is delivered with a recovery partition that allows you to restore the original operating system image and firmware.

To access the recovery functionality, open the Windows control panel, select "Update & Security" > "Recovery" > "Restart Now" and wait for the "R&S Recovery Environment" to start.



You can also use the [Recovery Tab](#) of the "System Config" dialog to boot into the recovery environment.

To restore the original operating system image and firmware, proceed as follows:

1. In the "R&S Recovery Environment" select "Factory Default Restore"
2. Wait for the reimaging process to complete
3. Reboot the instrument

After the restore, upgrade to the desired firmware version (see [Chapter 11.1.2, "Firmware Installation"](#), on page 1150).

## 11.3 Interfaces and Connectors

This chapter provides a detailed description of the rear panel connectors of the R&S ZND. An overview of the available front and rear panel is given in the Getting Started guide (see [Chapter 4.2, "Instrument Tour"](#), on page 28).

**EMI Suppression**

Notice the instructions in [Chapter 4.1.5, "EMI Suppression"](#), on page 22.

### 11.3.1 Rear Panel Connectors

The rear panel of the R&S ZND provides various connectors for external devices and control signals.

### 11.3.1.1 USER PORT

25-pole D-Sub connector used as an input and output for low-voltage (3.3 V) TTL control signals. Some of the lines can be configured (see [CONTROL Commands](#) and [OUTPUT Commands](#)).



Table 11-1: VNA User Port: Pole Assignment

| Pin No. | Name              | Input (I) or Output (O) | Function                                                                                                                                                                                                                                                                                                                                                   |
|---------|-------------------|-------------------------|------------------------------------------------------------------------------------------------------------------------------------------------------------------------------------------------------------------------------------------------------------------------------------------------------------------------------------------------------------|
| 1       | AGND              | -                       | Ground                                                                                                                                                                                                                                                                                                                                                     |
| 2       | UC_EXT_TRG_IN     | I                       | External trigger 1 input, 5 V tolerant *)                                                                                                                                                                                                                                                                                                                  |
| 3       | AGND              | -                       | Ground                                                                                                                                                                                                                                                                                                                                                     |
| 4       | UC_BUSY           | O                       | Hardware measurement time                                                                                                                                                                                                                                                                                                                                  |
| 5       | AGND              | -                       | Ground                                                                                                                                                                                                                                                                                                                                                     |
| 6       | READY FOR TRIGGER | O                       | Measurement completed, ready for new trigger                                                                                                                                                                                                                                                                                                               |
| 7       | AGND              | -                       | Ground                                                                                                                                                                                                                                                                                                                                                     |
| 8       | UC_CH_BIT0        | O                       | Channel bit 0;<br>see <a href="#">CONTROL:AUXiliary:C[:DATA]</a> and <a href="#">OUTPUT&lt;Ch&gt;:UPORT[:VALue]</a>                                                                                                                                                                                                                                        |
| 9       | UC_CH_BIT1        | O                       | Channel bit 1                                                                                                                                                                                                                                                                                                                                              |
| 10      | UC_CH_BIT2        | O                       | Channel bit 2                                                                                                                                                                                                                                                                                                                                              |
| 11      | UC_CH_BIT3        | O                       | Channel bit 3                                                                                                                                                                                                                                                                                                                                              |
| 12      | AGND              | -                       | Ground                                                                                                                                                                                                                                                                                                                                                     |
| 13      | UC_PASS1          | O                       | Pass/fail result of limit check 1; TTL Out Pass 1 (see <a href="#">TTL1 Pass / TTL2 Pass</a> )                                                                                                                                                                                                                                                             |
| 14      | UC_PASS2          | O                       | Pass/fail result of limit check 2; TTL Out Pass 2                                                                                                                                                                                                                                                                                                          |
| 15      | AGND              | -                       | Ground                                                                                                                                                                                                                                                                                                                                                     |
| 16      | UC_DRV_PORT1      | O                       | Used as drive ports ( <a href="#">OUTPUT:UPORT:ECBits OFF</a> ) or channel bits ( <a href="#">OUTPUT:UPORT:ECBits ON</a> ; default)<br>If used as drive ports, DRIVE PORT <i>i</i> is active while test port <i>i</i> is the source port.<br>If used as channel bits, the pin states can be defined using <a href="#">OUTPUT&lt;Ch&gt;:UPORT[:VALue]</a> . |
| 17      | UC_DRV_PORT2      | O                       |                                                                                                                                                                                                                                                                                                                                                            |
| 18      | UC_DRV_PORT3      | O                       |                                                                                                                                                                                                                                                                                                                                                            |
| 19      | UC_DRV_PORT4      | O                       |                                                                                                                                                                                                                                                                                                                                                            |
| 20      | AGND              | -                       | Ground                                                                                                                                                                                                                                                                                                                                                     |
| 21      | UC_EXT_GEN_TRG    | O                       | Control signal for external generator                                                                                                                                                                                                                                                                                                                      |
| 22      | UC_EXT_GEN_BLANK  | I                       | Handshake signal from external generator                                                                                                                                                                                                                                                                                                                   |
| 23      | AGND              | -                       | Ground                                                                                                                                                                                                                                                                                                                                                     |



| Pin No. | Name    | Input (I) or Output (O) | Function                               |
|---------|---------|-------------------------|----------------------------------------|
| 24      | UC_FOSW | I                       | Control input A, 5 V tolerant          |
| 25      | UC_TRG2 | I                       | External trigger 2 input, 5 V tolerant |

\*) Feeding in the external trigger signal via the BNC connector EXT TRIG IN is equivalent. The minimum pulse width of the trigger signals is 1  $\mu$ s.



### EMI Suppression

Use only double shielded cables or disconnect the input pins of the USER PORT connector to avoid spurious input signals which may cause undesirable events.

This is of particular importance for the external trigger input (pin no. 2) if the EXT TRIG IN input is used.

#### 11.3.1.2 EXT TRIG IN



BNC female connector for external trigger input; see "[FreeRun / External / Manual / Multiple Triggers](#)" on page 366. The external trigger input signal must be a 3.3 V or 5 V TTL signal with a minimum pulse width of 1  $\mu$ s. The trigger input has a high input impedance ( $> 10$  k $\Omega$ ).

#### 11.3.1.3 EXT TRIG OUT



BNC female connectors for external trigger output; see "[Output trigger](#)" on page 365. The R&S ZND trigger output provides a configurable 5 V TTL trigger signal. The output impedance is approximately 50 Ohm.

### 11.3.2 LAN Interface

To be integrated in a LAN, the instrument is equipped with a LAN interface, consisting of an RJ-45 connector, a network interface card and protocols. The network interface card supports IEEE 802.3 for a 10 Mbps Ethernet and IEEE 802.3u for a 100 Mbps Ethernet.

Instrument access is possible via the VXI-11 protocol. It is usually achieved from high level programming platforms by using the Virtual Instrument Software Architecture (VISA) library as an intermediate abstraction layer. VISA encapsulates the low-level function calls and thus makes the transport interface transparent for the user. See also [Chapter 7.1, "Introduction to Remote Control"](#), on page 559.

#### 11.3.2.1 VXI-11 Interface Messages

The following VXI-11 interface messages (also termed low-level control messages) are also supported by the GPIB Explorer.

| Command | Meaning               | Effect on the instrument                                                                                                                                          |
|---------|-----------------------|-------------------------------------------------------------------------------------------------------------------------------------------------------------------|
| @DCL    | Device Clear          | Aborts the processing of the commands just received and sets the command processing software to a defined initial state. Does not change the instrument settings. |
| @GET    | Group Execute Trigger | Triggers the active measurement sequence (e.g. a sweep). The effect of the command is the same as with that of a pulse at the external trigger signal input.      |
| @LOC    | Go to Local           | Transition to the "local" state (manual control).                                                                                                                 |
| @REM    | Go to Remote          | Transition to the "remote" state (remote control).                                                                                                                |

### 11.3.3 GPIB Interface

The R&S ZND can be equipped with a GPIB (IEC/IEEE) bus interface (option R&S ZND-B10). The interface connector labeled "GPIB" is located on the rear panel of the instrument. The GPIB bus interface is intended for remote control of the R&S ZND from a controller.

#### Characteristics of the interface

- 8-bit parallel data transfer
- Bidirectional data transfer
- Three-line handshake
- High data transfer rate of max. 1 MByte/s
- Up to 15 devices can be connected
- Wired OR if several instruments are connected in parallel

#### Pin assignment

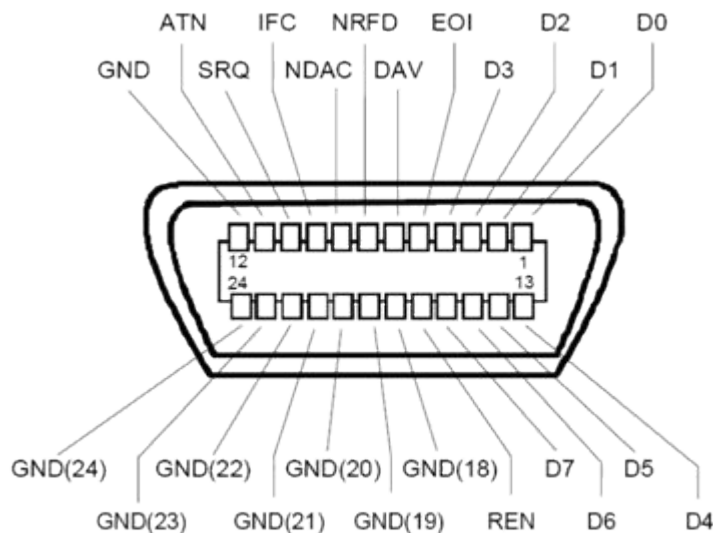

### Bus lines

- Data bus with 8 lines D0 to D7:  
The transmission is bit-parallel and byte-serial in the ASCII/ISO code. D0 is the least significant bit, D7 the most significant bit.
- Control bus with five lines:
  - IFC** (Interface Clear): active LOW resets the interfaces of the instruments connected to the default setting.
  - ATN** (Attention): active LOW signals the transmission of interface messages, inactive HIGH signals the transmission of device messages.
  - SRQ** (Service Request): active LOW enables the connected device to send a service request to the controller.
  - REN** (Remote Enable): active LOW permits switchover to remote control.
  - EOI** (End or Identify): has two functions in connection with ATN:
    - ATN=HIGH active LOW marks the end of data transmission.
    - ATN=LOW active LOW triggers a parallel poll.
- Handshake bus with three lines:
  - DAV** (Data Valid): active LOW signals a valid data byte on the data bus.
  - NRFD** (Not Ready For Data): active LOW signals that one of the connected devices is not ready for data transfer.
  - NDAC** (Not Data Accepted): active LOW signals that the instrument connected is accepting the data on the data bus.

The R&S ZND provides several functions to communicate via GPIB bus. They are described in the following sections.

#### 11.3.3.1 Interface Functions

Instruments which can be controlled via GPIB bus can be equipped with different interface functions. The interface functions for the R&S ZND are listed in the following table.

| Control character | Interface function                                                                      |
|-------------------|-----------------------------------------------------------------------------------------|
| SH1               | Handshake source function (source handshake), full capability                           |
| AH1               | Handshake sink function (acceptor handshake), full capability                           |
| L4                | Listener function, full capability, de-addressed by MTA.                                |
| T6                | Talker function, full capability, ability to respond to serial poll, deaddressed by MLA |
| SR1               | Service request function (Service Request), full capability                             |
| PP1               | Parallel poll function, full capability                                                 |
| RL1               | Remote/Local switch over function, full capability                                      |
| DC1               | Reset function (Device Clear), full capability                                          |
| DT1               | Trigger function (Device Trigger), full capability                                      |

### 11.3.3.2 Interface Messages

Interface messages are transmitted to the instrument on the data lines, with the attention line being active (LOW). They serve to communicate between controller and instrument.

#### Universal commands

Universal commands are encoded in the range 10 through 1F hex. They are effective for all instruments connected to the bus without previous addressing.

| Command                            | QuickBASIC command              | Effect on the instrument                                                                                                                                          |
|------------------------------------|---------------------------------|-------------------------------------------------------------------------------------------------------------------------------------------------------------------|
| DCL<br>(Device Clear)              | IBCMD (controller %, CHR\$(20)) | Aborts the processing of the commands just received and sets the command processing software to a defined initial state. Does not change the instrument settings. |
| IFC<br>(Interface Clear)           | IBSIC (controller%)             | Resets the interfaces to the default setting.                                                                                                                     |
| LLO<br>(Local Lockout)             | IBCMD (controller %, CHR\$(17)) | The LOC/IEC ADDR key is disabled.                                                                                                                                 |
| SPE<br>(Serial Poll Enable)        | IBCMD (controller %, CHR\$(24)) | Ready for serial poll                                                                                                                                             |
| SPD<br>(Serial Poll Disable)       | IBCMD (controller %, CHR\$(25)) | End of serial poll                                                                                                                                                |
| PPU<br>(Parallel Poll Unconfigure) | IBCMD (controller %, CHR\$(21)) | End of the parallel-poll state                                                                                                                                    |

#### Addressed commands

Addressed commands are encoded in the range 00 through 0F hex. They are only effective for instruments addressed as listeners.

| Command                        | QuickBASIC command | Effect on the instrument                                                                                                                                         |
|--------------------------------|--------------------|------------------------------------------------------------------------------------------------------------------------------------------------------------------|
| GET<br>(Group Execute Trigger) | IBTRG (device%)    | Triggers a previously active device function (e.g. a sweep). The effect of the command is the same as with that of a pulse at the external trigger signal input. |
| GTL<br>(Go to Local)           | IBLOC (device%)    | Transition to the "Local" state (manual control)                                                                                                                 |

| Command                          | QuickBASIC command     | Effect on the instrument                                                                                                                                         |
|----------------------------------|------------------------|------------------------------------------------------------------------------------------------------------------------------------------------------------------|
| PPC<br>(Parallel Poll Configure) | IBPPC (device%, data%) | Configures the instrument for parallel poll. Additionally, the QuickBASIC command executes PPE/PPD.                                                              |
| SDC<br>(Selected Device Clear)   | IBCLR (device%)        | Aborts the processing of the commands just received and sets the command processing software to a defined initial state. Does not change the instrument setting. |

### 11.3.3.3 Instrument Messages

Instrument messages (commands) are transferred on the data lines of the GPIB bus while the ATN line is not active. ASCII code is used.

Structure and syntax of the instrument messages are described in [Chapter 8, "Command Reference"](#), on page 594. The chapter also provides a detailed description of all messages implemented by the analyzer.

## 11.3.4 Handler I/O (Universal Interface)

### Option R&S ZN-B14

A network analyzer which is equipped with a Handler I/O (Universal Interface) option, can interact with an external part handler. The digital control signals on the interface connector indicate the possible start and the end of a measurement, as well as a global limit check result. Typically, the handler will insert the device to be tested into a test fixture, provide a trigger pulse to initiate the measurement, remove and replace the device after the measurement is complete and sort it into pass/fail bins. A sample flow diagram for this process is shown below.

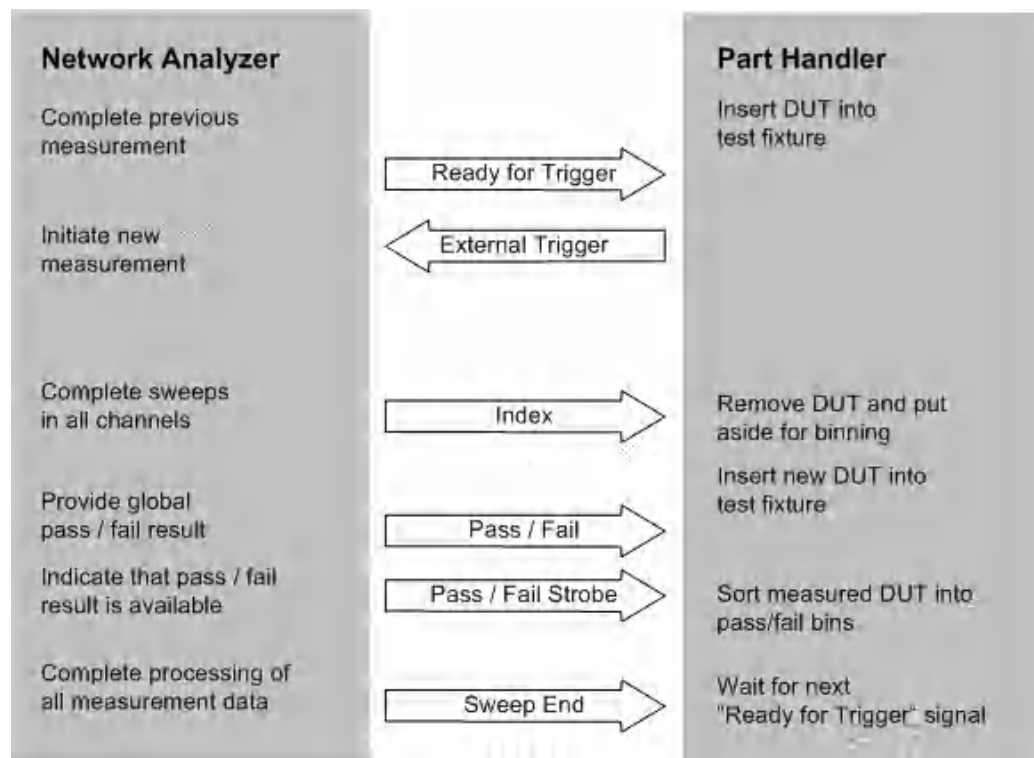

Figure 11-2: Possible stages of an automated test

### Preparation of the network analyzer and the part handler

The network analyzer configuration depends on the measurement to be made. Starting from the preset state, you will usually have to adjust the following settings:

1. Enable external trigger:  
CHANNEL – [TRIGGER] > "Trigger" > "External"
2. (Optional:) Select single sweep mode: CHANNEL – [SWEEP] > "Sweep Control" > "Single"
3. Define limit lines and enable the limit check: TRACE – [LINE] > "Limit Test" > ...

The Universal Interface connector must be connected to the part handler using an appropriate cable. If required, configure the data ports to ensure that the network analyzer and the part handler are compatible.

#### 11.3.4.1 Control Signals

Most of the signals in the figure below are controlled by the measurement. It is possible though to query the transitions of the "Input 1" signal, to configure the "Output 1", "Output 2", "Sweep End", and "Pass/Fail" signals and to route the "Index" and "Ready for Trigger" signals using SCPI commands.

- `CONTROL:HANDLER:INPut?` queries the high to low transitions of the "Input 1" signal.

- The `CONTROL:HANDler:OUTPut<Pt>...` commands set the output signals to a definite state and specify whether this state will change to "Low" when the Input 1 signal goes to "Low". This mechanism provides either static output signals or output signals which are controlled by Input 1.
- The "Index" and "Ready for Trigger" signals can be routed to pins 20 and 21 of the Universal Interface connector, where they replace the PORT B6 and PORT B7 input/output signals. See [Chapter 11.3.4.2, "Data Ports"](#), on page 1163.
- The `CONTROL:HANDler:PASSfail...` commands configure the "Pass/Fail" signal and query the global pass/fail status of the last measurement.

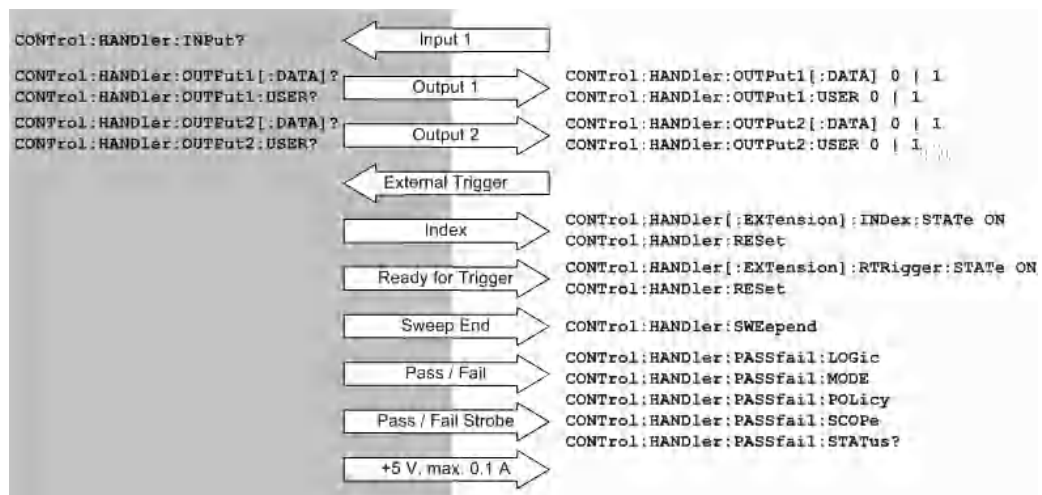

Figure 11-3: Control signals and power supply

SCPI commands: See [Chapter 8.3.3, "CONTROL Commands"](#), on page 791

#### 11.3.4.2 Data Ports

In addition to the control signals, the Universal Interface provides four bi-directional data ports A, B, C, D. The data ports must be configured explicitly using SCPI commands; they are not controlled by the measurement.

- With an output data port, you can configure the part handler or other devices used in testing from the network analyzer.
- With an input data port, you can configure the network analyzer using external signals and an appropriate control program.

Device configurations via data port signals are usually performed in a preliminary stage, before the actual measurement sequence. If the "Index" and "Ready for Trigger" signals are enabled at this stage (see [Chapter 11.3.4.1, "Control Signals"](#), on page 1162), they replace the PORT B6 and PORT B7 signals. Port B can still be used as a 6-bit parallel input/output port.

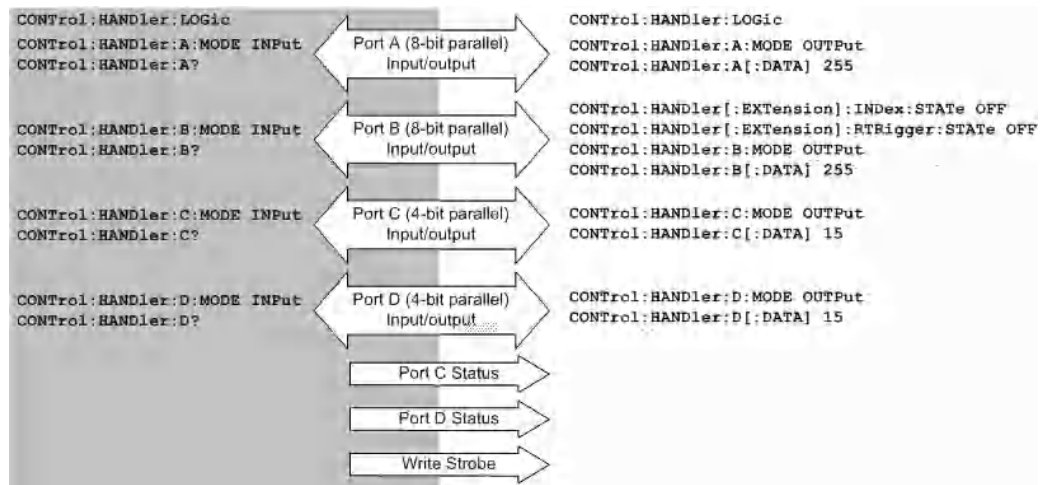

Figure 11-4: Data ports and related signals

### Combined ports (ports E, F, G, H)

A combination of ports A / B and ports C / D provides two additional 16-bit and 8-bit-wide bidirectional ports. The combined ports are termed ports E and F, respectively. A combination of ports A / B / C and ports A / B / C / D provides two 20-bit and 24-bit-wide bidirectional ports. These combined ports are termed ports G and H.

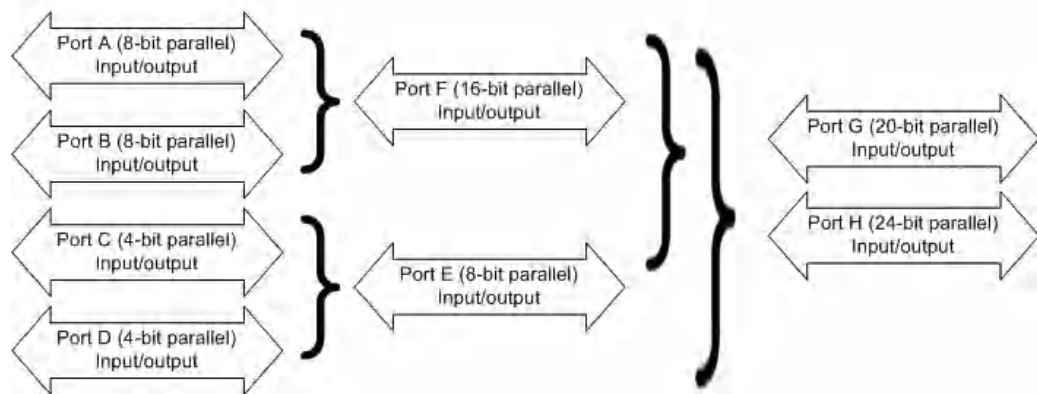

Figure 11-5: Definition of ports E, F, G, H

The properties of the combined ports are as follows:

- The signal direction (input or output) is according to the configuration of ports A, B, C, and D. E.g. to write data to port G (H), ports A, B, and C (A, B, C, and D) must be configured as output ports.
- Data can be read and written using the `CONTROL:HANDLER:E|F|G|H[:DATA]` commands.
- The bit order is D3 ... D0 C3 ... C0 (port E), B7 ... B0 A7 ... A0 (port F), C3 ... C0 B7 ... B0 A7 ... A0 (port G), and D3 ... D0 C3 ... C0 B7 ... B0 A7 ... A0 (port H).



SCPI commands: See [Chapter 8.3.3, "CONTROL Commands"](#), on page 791

### 11.3.4.3 Universal Interface Connector

The Handler I/O (Universal Interface) option includes a Centronics 36 input/output connector.



The Handler I/O option R&S ZN-B14 must be installed by a Rohde & Schwarz service representative.

The pin assignment of the connector is shown below. A slash (/) at the beginning of the signal name indicates that it is an active low (negative logic) signal.

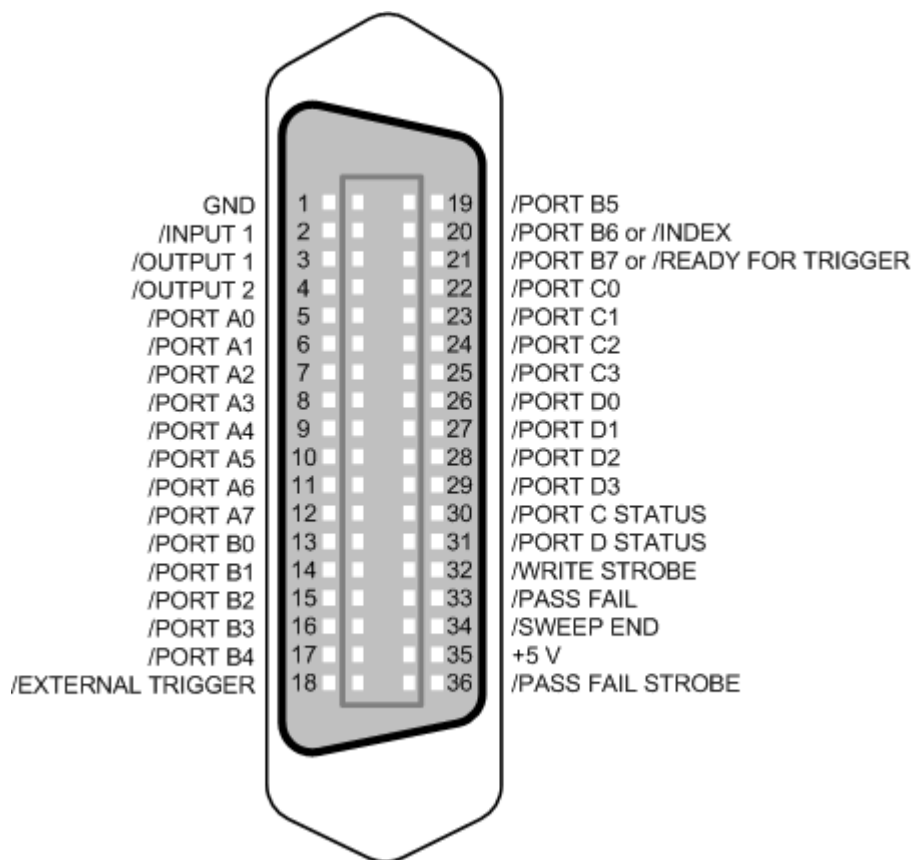

**Figure 11-6: Pin assignment of the Universal Interface connector**

The input and output signals at the connector are described below.

| Pin No. | Signal   | Input (I) or Output (O) | Description                                                                                                        |
|---------|----------|-------------------------|--------------------------------------------------------------------------------------------------------------------|
| 1       | GND      | –                       | Ground                                                                                                             |
| 2       | /INPUT 1 | I                       | When a negative pulse is fed to this port, the /OUTPUT 1 and /OUTPUT 2 signals (pins no. 3 and 4) change to "Low". |

| Pin No. | Signal                         | Input (I) or Output (O) | Description                                                                                                                                                                                                        |
|---------|--------------------------------|-------------------------|--------------------------------------------------------------------------------------------------------------------------------------------------------------------------------------------------------------------|
| 3       | /OUTPUT 1                      | O                       | Changes to "Low" when the /INPUT 1 (pin no. 2) receives a negative pulse.                                                                                                                                          |
| 4       | /OUTPUT 2                      | O                       | Changes to "Low" when the /INPUT 1 (pin no. 2) receives a negative pulse.                                                                                                                                          |
| 5       | /PORT A0                       | I or O                  | Port A, bit no. 0 (8-bit parallel input or output port)                                                                                                                                                            |
| 6       | /PORT A1                       | I or O                  | Port A, bit no. 1                                                                                                                                                                                                  |
| 7       | /PORT A2                       | I or O                  | Port A, bit no. 2                                                                                                                                                                                                  |
| 8       | /PORT A3                       | I or O                  | Port A, bit no. 3                                                                                                                                                                                                  |
| 9       | /PORT A4                       | I or O                  | Port A, bit no. 4                                                                                                                                                                                                  |
| 10      | /PORT A5                       | I or O                  | Port A, bit no. 5                                                                                                                                                                                                  |
| 11      | /PORT A6                       | I or O                  | Port A, bit no. 6                                                                                                                                                                                                  |
| 12      | /PORT A7                       | I or O                  | Port A, bit no. 7                                                                                                                                                                                                  |
| 13      | /PORT B0                       | I or O                  | Port B, bit no. 0 (8-bit parallel input or output port)                                                                                                                                                            |
| 14      | /PORT B1                       | I or O                  | Port B, bit no. 1                                                                                                                                                                                                  |
| 15      | /PORT B2                       | I or O                  | Port B, bit no. 2                                                                                                                                                                                                  |
| 16      | /PORT B3                       | I or O                  | Port B, bit no. 3                                                                                                                                                                                                  |
| 17      | /PORT B4                       | I or O                  | Port B, bit no. 4                                                                                                                                                                                                  |
| 18      | /EXTERNAL TRIGGER              | I                       | External trigger signal                                                                                                                                                                                            |
| 19      | /PORT B5                       | I or O                  | Port B, bit no. 5                                                                                                                                                                                                  |
| 20      | /PORT B6 or /INDEX             | I or O<br>O             | Port B, bit no. 6<br>The /INDEX signal changes to "Low" when a measurement is complete (all sweeps in all channels have been performed; the DUT can be removed, but the measurement results may not be valid yet). |
| 21      | /PORT B7 or /READY FOR TRIGGER | I or O<br>O             | Port B, bit no. 7<br>The /READY FOR TRIGGER signal changes to "Low" when the analyzer is ready to receive a trigger for a new measurement.                                                                         |
| 22      | /PORT C0                       | I or O                  | Port C, bit no. 0 (4-bit parallel input or output port)                                                                                                                                                            |
| 23      | /PORT C1                       | I or O                  | Port C, bit no. 1                                                                                                                                                                                                  |
| 24      | /PORT C2                       | I or O                  | Port C, bit no. 2                                                                                                                                                                                                  |
| 25      | /PORT C3                       | I or O                  | Port C, bit no. 3                                                                                                                                                                                                  |
| 26      | /PORT D0                       | I or O                  | Port D, bit no. 0 (4-bit parallel input or output port)                                                                                                                                                            |
| 27      | /PORT D1                       | I or O                  | Port D, bit no. 1                                                                                                                                                                                                  |
| 28      | /PORT D2                       | I or O                  | Port D, bit no. 2                                                                                                                                                                                                  |
| 29      | /PORT D3                       | I or O                  | Port D, bit no. 3                                                                                                                                                                                                  |
| 30      | /PORT C STATUS                 | O                       | Indicates the status of port C:<br><ul style="list-style-type: none"> <li>• Low: port C is an input port</li> <li>• High: port C is an output port</li> </ul>                                                      |

| Pin No. | Signal            | Input (I) or Output (O) | Description                                                                                                                                                                                                                                                                                      |
|---------|-------------------|-------------------------|--------------------------------------------------------------------------------------------------------------------------------------------------------------------------------------------------------------------------------------------------------------------------------------------------|
| 31      | /PORT D STATUS    | O                       | Indicates the status of port D: <ul style="list-style-type: none"> <li>• Low: port D is an input port</li> <li>• High: port D is an output port</li> </ul>                                                                                                                                       |
| 32      | /WRITE STROBE     | O                       | Changes to "Low" when valid data is present at any of the output ports (i.e. when the output level at any port changes).                                                                                                                                                                         |
| 33      | /PASS FAIL        | O                       | Indicates the status of the global limit check for the last measurement: <ul style="list-style-type: none"> <li>• Low: global limit check failed</li> <li>• High: global limit check passed</li> </ul> Other configurations are possible; see <code>CONTrol:HANDler:PASSfail...</code> commands. |
| 34      | /SWEEP END        | O                       | Indicates the end of the measurement. Changes to "Low" after all sweeps in all channels have been completed and the measurement data has been processed. Alternative configurations: see <code>CONTrol:HANDler:SWEEPend</code> .                                                                 |
| 35      | +5 V DC           | O                       | DC power supply for external devices; +5 V $\pm$ 250 mV, max. 0.1 A                                                                                                                                                                                                                              |
| 36      | /PASS FAIL STROBE | O                       | Changes to "Low" when limit check results are present on /PASS FAIL (pin no. 33).                                                                                                                                                                                                                |

All digital input signals must be TTL compatible with an allowed input voltage range between  $-0.5$  V and  $+5.5$  V. The circuit diagram of the input path is shown below.

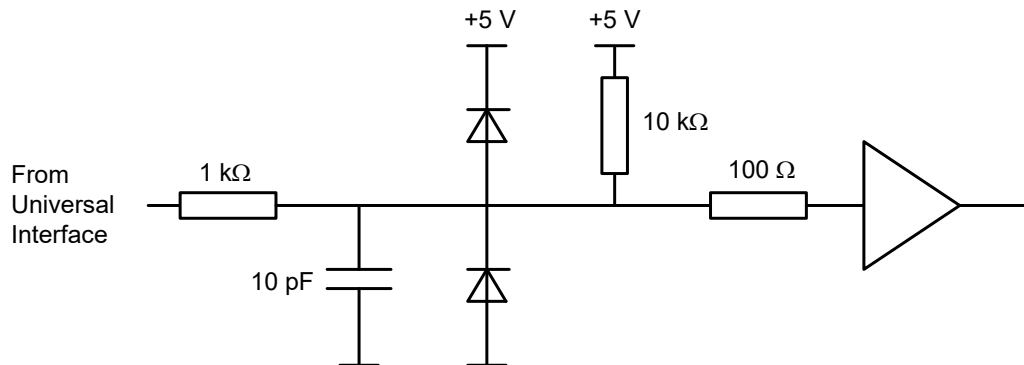

**Figure 11-7: Circuit diagram of the input path**

Digital output signals are low-voltage TTL compatible with output voltages between  $0$  V and  $+5$  V. The circuit diagram of the output path is shown below.

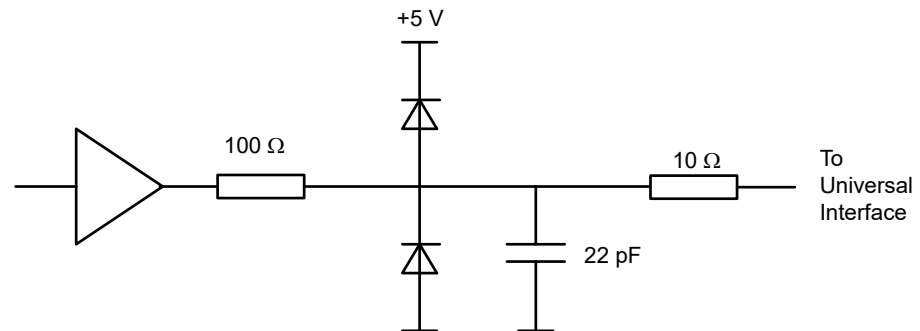

Figure 11-8: Circuit diagram of the output path

The default configuration of the signals is listed below. Notice that \*RST or "Preset" do not change the configuration of the Universal Interface. Use `CONTrol:HANDler:RESet` to restore default values.

| Signal                         | *RST Configuration                        |
|--------------------------------|-------------------------------------------|
| Port A, Port B                 | Output ports, all bits "High" (decimal 0) |
| Port C, Port D                 | Input ports                               |
| /PORT C STATUS, /PORT D STATUS | "Low"                                     |
| /OUTPUT 1, /OUTPUT 2           | "High"                                    |
| /SWEEP END                     | "High"                                    |
| /PASS_FAIL                     | "High"                                    |

SCPI commands: `CONTrol:HANDler:RESet` (resets all configurable signals)

#### 11.3.4.4 Timing of Control Signals

The timing of the essential measurement control signals is shown in the figure below. The duration of the shaded time intervals depends on the measurement settings.

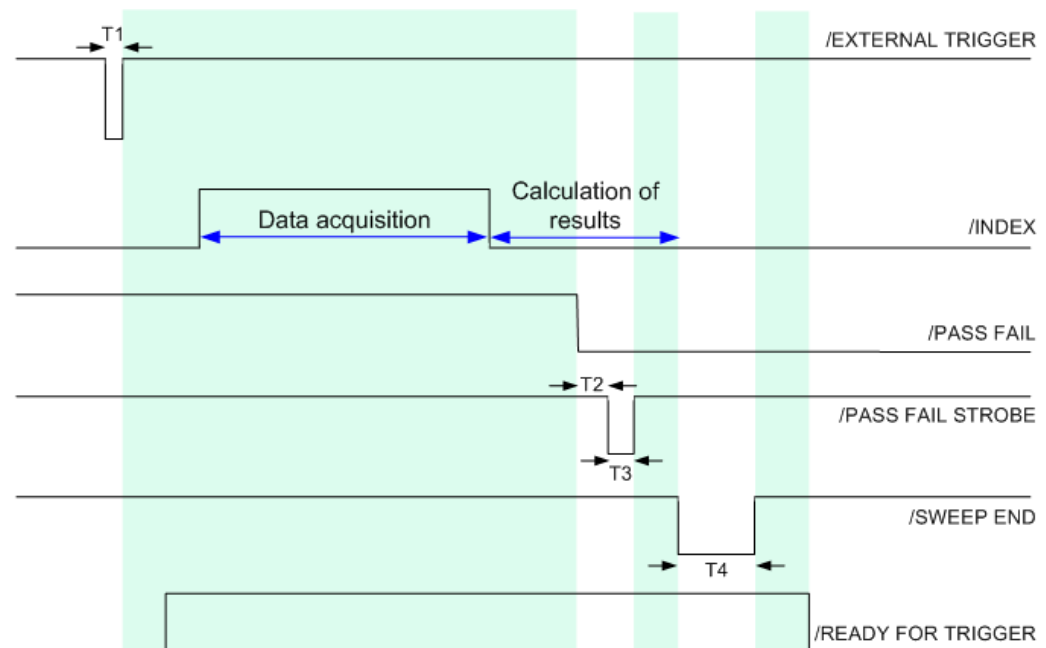

Figure 11-9: Timing of measurement control signals

The figure above corresponds to the default configuration of the /PASS FAIL signal. For alternative configurations, refer to the documentation of the `CONTROL:HANDLER:PASSfail...` commands in [Chapter 8.3.3, "CONTROL Commands"](#), on page 791. The figure contains the following pulse durations and response times.

| Time | Description                         | Value                    |
|------|-------------------------------------|--------------------------|
| T1   | Pulse duration of /EXTERNAL TRIGGER | Minimum value: 1 $\mu$ s |
| T2   | Response time of /PASS FAIL STROBE  | 1 $\mu$ s                |
| T3   | Pulse duration of /PASS FAIL STROBE | 1 $\mu$ s                |
| T4   | Pulse duration of /SWEEP END        | 12 $\mu$ s               |

The timing of the data port signals and the input/output signals is as follows:

- The low pulse of the /WRITE STROBE signal occurs approx. 0.1  $\mu$ s after a value is written to the output ports A to D. The pulse duration of the /WRITE STROBE signal is 1  $\mu$ s.
- The low pulse of the /OUTPUT 1 or /OUTPUT 2 signals (if enabled) occur approx. 0.6  $\mu$ s after the falling edge of the /INPUT 1 signal.

## 11.4 Maintenance

The R&S ZND vector network analyzer does not require any special maintenance.

For our support center address and a list of useful R&S contact addresses, refer to the "Contact" page at the beginning of the Help system.

### 11.4.1 Cleaning

---

**⚠ WARNING****Risk of electric shock**

If moisture enters the casing, for example if you clean the instrument using a moist cloth, contact with the instrument can lead to electric shock. Before cleaning the instrument other than with a dry cloth, make sure that the instrument is switched off and disconnected from all power supplies.

---

**NOTICE****Instrument damage caused by cleaning agents**

Cleaning agents contain substances such as solvents (thinners, acetone, etc.), acids, bases, or other substances. Solvents can damage the front panel labeling, plastic parts, or screens, for example.

Never use cleaning agents to clean the outside of the instrument. Use a soft, dry, lint-free dust cloth instead.

---

**NOTICE****Risk of instrument damage due to obstructed fans**

If the instrument is operated in dusty areas, the fans become obstructed by dust or other particles over time. Check and clean the fans regularly to ensure that they always operate properly. If the instrument is run with obstructed fans for a longer period, the instrument overheats, which can disturb the operation and even cause damage.

---

1. Clean the outside of the instrument using a soft, dry, lint-free dust cloth.
2. Check and clean the fans regularly to ensure that they always operate properly.

### 11.4.2 Storing and Packing the Instrument

The vector network analyzer can be stored at the temperature range quoted in the data sheet. When it is stored for a longer period of time, the unit must be protected against dust.

## 11.5 Showroom Mode

In "Showroom Mode" the R&S ZND uses a configurable recall set whenever the device is (re-)started or the [Preset] key is pressed. However, it can only be enabled by directly editing the Windows registry.

1. Run the R&S ZND and configure it as required for the intended showroom operation.
2. Save the configuration as described in [Chapter 6.14.1, "Recall Sets Tab"](#), on page 485. If necessary, move the recall set file (\*.znx|\*.znxml) to the appropriate location.
3. Under the registry key  
HKEY\_LOCAL\_MACHINE/SOFTWARE/Rohde-Schwarz/Vna, create a new subkey ShowroomMode.
4. Within the ShowroomMode-subkey, create the string value ShowroomSetup.
5. Modify the value ShowroomSetup: set its value data to the full path of the recall set. Use forward slashes as path separators, e.g. "C:/Documents and Settings/All Users/Rohde-Schwarz/Vna/RecallSets/ShowroomSet1.znx".

After the analyzer is restarted or "Preset", the specified recall set is loaded.

## 11.6 ENA Emulation Commands

The following table lists the commands implemented/overwritten for the ENA remote language.

| ENA Emulation Command                                                                                                 | R&S ZND Default Parser Command                                              |
|-----------------------------------------------------------------------------------------------------------------------|-----------------------------------------------------------------------------|
| CALCulate<Ch>:FSIMulator:SENDEd:DEEMbed:PORT<Pt>[:TYPE] {USER NONE}                                                   | CALCulate<Ch>:TRANSform:VNETworks:SENDEd:DEEMbedding<PhyPt>:TNDefinition    |
| CALCulate<Ch>:FSIMulator:SENDEd:DEEMbed:PORT<Pt>:USER:FILENAME <string>                                               | CALCulate<Ch>:TRANSform:VNETworks:SENDEd:DEEMbedding<PhyPt>:PARAMeters:DATA |
| CALCulate<Ch>:FSIMulator:SENDEd:DEEMbed:STATe {ON OFF 1 0}                                                            | n.a. (enabled channel-by-channel, port-by-port)                             |
| CALCulate{1..4}:FSIMulator:SENDEd:PMCir:cuit:STAT {ON OFF 1 0}                                                        | CALCulate<Ch>:TRANSform:VNETworks:SENDEd:EMBedding<PhyPt>[:STATe]           |
| CALCulate{1..4}:FSIMulator:SENDEd:PMCir:cuit:PORT<Pt>[:TYPE] {NONE PCSC PCSL PLPC PLSC PLSL SCPC SCPL SLPC SLPL USER} | CALCulate<Ch>:TRANSform:VNETworks:SENDEd:EMBedding<PhyPt>:TNDefinition      |
| CALCulate{1..4}:FSIMulator:SENDEd:PMCir:cuit:PORT<i>:PARAMeter:C <numeric>                                            | CALCulate<Ch>:TRANSform:VNETworks:SENDEd:EMBedding<PhyPt>:PARAMeters:C<Cmp> |

## ENA Emulation Commands

| ENA Emulation Command                                                                                                           | R&S ZND Default Parser Command                                              |
|---------------------------------------------------------------------------------------------------------------------------------|-----------------------------------------------------------------------------|
| CALCulate{1..4}:FSIMulator:SENDEd:PMCircuit:PORT<i>:PARAmeter:G <numeric>                                                       | CALCulate<Ch>:TRANSform:VNETworks:SENDEd:EMBedding<PhyPt>:PARAmeters:G<Cmp> |
| CALCulate{1..4}:FSIMulator:SENDEd:PMCircuit:PORT<i>:PARAmeter:L <numeric>                                                       | CALCulate<Ch>:TRANSform:VNETworks:SENDEd:EMBedding<PhyPt>:PARAmeters:L<Cmp> |
| CALCulate{1..4}:FSIMulator:SENDEd:PMCircuit:PORT<i>:PARAmeter:R <numeric>                                                       | CALCulate<Ch>:TRANSform:VNETworks:SENDEd:EMBedding<PhyPt>:PARAmeters:R<Cmp> |
| CALCulate{1..4}:FSIMulator:SENDEd:ZCONversion:STATe {ON OFF 1 0}                                                                | [SENSe<Ch>:]LPORt<LogPt>:ZDEFault[:STATe]                                   |
| CALCulate{1..4}:FSIMulator:SENDEd:ZCONversion:PORT<i>:Z0[:R] <numeric>                                                          | [SENSe<Ch>:]PORt<PhyPt>:ZREFerence                                          |
| CALCulate<Ch>:FSIMulator:STATe {ON OFF 1 0}                                                                                     | n.a. (enabled channel-by-channel, port-by-port)                             |
| CALCulate{1...4}[:SELEcted]:DATA:FDATa?<br>CALCulate{1...4}[:SELEcted]:DATA:SDATa?<br>CALCulate{1...4}[:SELEcted]:DATA:FMEMOry? | CALCulate<Chn>:DATA                                                         |
| CALCulate<Ch>[:SELEcted]FORMat                                                                                                  | CALCulate<Chn>:FORMat                                                       |
| CALCulate{1..4}[:SELEcted]:FUNCtion:TYPE {PTPeak STDEV MEAN MAXimum MINimum}                                                    | CALCulate<Chn>:STATistics:RESult?                                           |
| CALCulate{1..4}[:SELEcted]:FUNCtion:DOMain[:STATe] {ON OFF 1 0}                                                                 | CALCulate<Chn>:STATistics:DOMain:USER                                       |
| CALCulate{1..4}[:SELEcted]:FUNCtion:DOMain:STARt <value>                                                                        | CALCulate<Chn>:STATistics:DOMain:USER:STARt                                 |
| CALCulate{1..4}[:SELEcted]:FUNCtion:DOMain:STOP <value>                                                                         | CALCulate<Chn>:STATistics:DOMain:USER:STOP                                  |
| CALCulate{1..4}[:SELEcted]:FUNCtion:DATA?                                                                                       | CALCulate<Chn>:STATistics:RESult?                                           |
| CALCulate{1..4}[:SELEcted]:FUNCtion:EXECute                                                                                     | None (no action)                                                            |
| CALCulate{1...4}[:SELEcted]:LIMit[:STATe] {ON OFF 1 0}                                                                          | CALCulate<Chn>:LIMit:STATe                                                  |
| CALCulate{1...4}[:SELEcted]:LIMit:DISPlay[:STATe] {ON OFF 1 0}                                                                  | CALCulate<Chn>:LIMit:DISPlay[:STATe]                                        |
| CALCulate{1...4}[:SELEcted]:LIMit:FAIL?                                                                                         | CALCulate<Chn>:LIMit:FAIL?                                                  |
| CALCulate<Ch>[:SELEcted]:LIMit<Tr>:DATA                                                                                         | CALCulate<Chn>:LIMit:DATA                                                   |
| CALCulate{1...4}[:SELEcted]:MARKer{1...10}:COUPle {ON OFF 1 0}                                                                  | CALCulate:MARKer:COUPled[:STATe]                                            |
| CALCulate{1...4}[:SELEcted]:MARKer{1...10}:FUNCtion:TYPE {MAXimum MINimum PEAK LPEak RPEak TARGet LTARGet RTARGet}              | CALCulate<Chn>:MARKer<Mk>:FUNCtion[:SELEct]                                 |
| CALCulate{1...4}[:SELEcted]:MARKer{1...10}:DISCreate {ON OFF 1 0}                                                               | CALCulate<Chn>:MARKer<Mk>:MODE                                              |



## ENA Emulation Commands

| ENA Emulation Command                                                                                      | R&S ZND Default Parser Command                |
|------------------------------------------------------------------------------------------------------------|-----------------------------------------------|
| CALCulate{1...4}[:SElected]:MARKer{1...10}:REF-erence[:STATe] {ON OFF 1 0}                                 | CALCulate<Chn>:MARKer<Mk>:REFerence [:STATe]  |
| CALCulate{1...4}[:SElected]:MARKer{1...10}:FUNCtion:EXECute                                                | CALCulate<Chn>:MARKer<Mk>:SEARCh [:IMMediate] |
| CALCulate{1...4}[:SElected]:MARKer{1...10}[:STATe] {ON OFF 1 0}                                            | CALCulate<Chn>:MARKer<Mk>[:STATe]             |
| CALCulate{1...4}[:SElected]:MARKer{1...10}:X<numeric>                                                      | CALCulate<Chn>:MARKer<Mk>:X                   |
| CALCulate{1...4}[:SElected]:MARKer{1...10}:Y?                                                              | CALCulate<Chn>:MARKer<Mk>:Y                   |
| CALCulate{1...4}[:SElected]:MATH:FUNCtion {NORMal ADD SUBTract MULTIply DIVide}                            | CALCulate<Chn>:MATH:FUNCtion                  |
| :CALCulate{1...4}[:SElected]:MATH:MEMorize                                                                 | CALCulate<Chn>:MATH:MEMorize                  |
| CALCulate{1...4}:PARAmeter:COUNT <numeric>                                                                 |                                               |
| CALCulate{1...4}:PARAmeter{1...7}:DEFine {S11 S21 S31 S41 S12 S22 S32 S42 S13 S23 S33 S43 S14 S24 S34 S44} | CALCulate<Ch>:PARAmeter:DEFine                |
| CALCulate{1...4}:PARAmeter{1...7}:SElect [<string>]                                                        | CALCulate<Ch>:PARAmeter:SElect                |
| CALCulate{1...4}[:SElected]:SMOothing:APERture<numeric>                                                    | CALCulate<Chn>:SMOothing:APERture             |
| CALCulate{1...4}[:SElected]:SMOothing[:STATe] {ON OFF 1 0}                                                 | CALCulate<Chn>:SMOothing[:STATe]              |
| CONTRol:HANDler:A[:DATA] <numeric>                                                                         | CONTRol:HANDler:A[:DATA]                      |
| CONTRol:HANDler:B[:DATA] <numeric>                                                                         | CONTRol:HANDler:B[:DATA]                      |
| CONTRol:HANDler:C[:DATA] <numeric>                                                                         | CONTRol:HANDler:C[:DATA]                      |
| CONTRol:HANDler:D[:DATA] <numeric>                                                                         | CONTRol:HANDler:D[:DATA]                      |
| CONTRol:HANDler:A:MODE {INPut OUTPut}                                                                      | CONTRol:HANDler:A:MODE                        |
| CONTRol:HANDler:B:MODE {INPut OUTPut}                                                                      | CONTRol:HANDler:B:MODE                        |
| CONTRol:HANDler:C:MODE {INPut OUTPut}                                                                      | CONTRol:HANDler:C:MODE                        |
| CONTRol:HANDler:D:MODE {INPut OUTPut}                                                                      | CONTRol:HANDler:D:MODE                        |
| CONTRol:HANDler[:EXTension]:INdex:STATe {ON OFF 1 0}                                                       | CONTRol:HANDler[:EXTension]:INdex:STATe       |
| CONTRol:HANDler:OUTPut{1...2}[:DATA] {1 0}                                                                 | CONTRol:HANDler:OUTPut<Pt>[:DATA]             |
| DISPlay:ANNotation:FREQuency[:STATe] {ON OFF 1 0}                                                          | DISPlay:ANNotation:FREQuency[:STATe]          |
| DISPlay:ANNotation:MESSAge:STATe {ON OFF 1 0}                                                              | SYSTem:ERRor:DISPlay:STATe                    |
| DISPlay:ARRange {TILE CAScAdE OVERlay STACK SPLit QUAD}                                                    | DISPlay:LAYout                                |

## ENA Emulation Commands

| ENA Emulation Command                                           | R&S ZND Default Parser Command                                |
|-----------------------------------------------------------------|---------------------------------------------------------------|
| DISPlay:CClear                                                  | *CLS is th closest, but this will also clear the error queue. |
| DISPlay:ENABLE {ON OFF 1 0}                                     | SYSTem:DISPlay:UPDate                                         |
| DISPlay:SPLit                                                   | DISPlay:LAYout:EXECute                                        |
| DISPlay:UPDate[:IMMediate]                                      | SYSTem:DISPlay:UPDate                                         |
| DISPlay:VISible {ON OFF 1 0}                                    | SYSTem:DISPlay:UPDate                                         |
| DISPlay:WINDow{1...4}:ACTivate <numeric_value>                  | INSTRument:NSElect                                            |
| DISPlay:WINDow{1...4}:MAXimize {ON OFF 1 0}                     | DISPlay[:WINDow<Wnd>]:MAXimize                                |
| DISPlay:WINDow:SPLit                                            |                                                               |
| DISPlay:WINDow{1...4}:TITLe:DATA <string>                       | DISPlay[:WINDow<Wnd>]:TITLe:DATA                              |
| DISPlay:WINDow{1...4}:TITLe[:STATe] {ON OFF 1 0}                | DISPlay[:WINDow<Wnd>]:TITLe[:STATe]                           |
| DISPlay:WINDow<Ch>:TRACe<Tr>:MEMory[:STATe] {ON OFF 1 0}        | TRACe:COPI                                                    |
| DISPlay:WINDow{1...4}:TRACe{1...7}:Y[:SCALE]:AUTO               | DISPlay[:WINDow<Wnd>]:TRACe<WndTr>:Y[:SCALE]:AUTO             |
| DISPlay:WINDow{1...4}:Y[:SCALE]:DIVisions <numeric>             | DISPlay[:WINDow<Wnd>]:TRACe<WndTr>:Y[:SCALE]:PDIVision        |
| DISPlay:WINDow{1...4}:Y[:SCALE]:RLEVel <numeric>                | DISPlay[:WINDow<Wnd>]:TRACe<WndTr>:Y[:SCALE]:RLEVel           |
| DISPlay:WINDow{1...4}:TRACe{1...7}:Y[:SCALE]:RPOStion <numeric> | DISPlay[:WINDow<Wnd>]:TRACe<WndTr>:Y[:SCALE]:RPOStion         |
| FORMat:BORDER {NORMal SWAPped}                                  | FORMat:BORDER                                                 |
| FORMat:DATA {ASCIi REAL}                                        | FORMat[:DATA]                                                 |
| INITiate{1...4}:CONTinuous {ON OFF 1 0}                         | INITiate<Ch>:CONTinuous                                       |
| INITiate{1...4}[:IMMediate]                                     | INITiate<Ch>[:IMMediate][:DUMMy]                              |
| MMEMemory:CATalog? <string>                                     | MMEMemory:CATalog?                                            |
| MMEMemory:COPI <string 1> <string 2>                            | MMEMemory:COPI                                                |
| MMEMemory:DELeTe <string>                                       | MMEMemory:DELeTe                                              |
| MMEMemory:LOAD:LIMit <string>                                   | MMEMemory:LOAD:LIMit                                          |
| MMEMemory:LOAD:SEGMENT <string>                                 | MMEMemory:LOAD:SEGMENT                                        |
| MMEMemory:LOAD[:STATe] <string>                                 | MMEMemory:LOAD:STATe                                          |
| MMEMemory:MDIRectory <string>                                   | MMEMemory:MDIRectory                                          |
| MMEMemory:STORE[:STATe] <string>                                | MMEMemory:STORE:STATe                                         |
| MMEMemory:STORE:FDATA <string>                                  | MMEMemory:STORE:TRACe                                         |

## ENA Emulation Commands

| ENA Emulation Command                                                                                                                                                                                                                                                                                                                    | R&S ZND Default Parser Command                                                                                               |
|------------------------------------------------------------------------------------------------------------------------------------------------------------------------------------------------------------------------------------------------------------------------------------------------------------------------------------------|------------------------------------------------------------------------------------------------------------------------------|
| MMEMory:STORe:LIMit <string>                                                                                                                                                                                                                                                                                                             | MMEMory:STORe:LIMit                                                                                                          |
| MMEMory:STORe:SEGMENT <string>                                                                                                                                                                                                                                                                                                           | MMEMory:STORe:SEGMENT                                                                                                        |
| MMEMory:STORe:SNP:DATA <filename>                                                                                                                                                                                                                                                                                                        | MMEMory:STORe:TRACe:PORTs                                                                                                    |
| MMEMory:STORe:SNP:TYPE:S1P <numeric>                                                                                                                                                                                                                                                                                                     | MMEMory:STORe:TRACe:PORTs                                                                                                    |
| MMEMory:STORe:SNP:TYPE:S2P <numeric1>, <numeric2>                                                                                                                                                                                                                                                                                        | MMEMory:STORe:TRACe:PORTs                                                                                                    |
| MMEMory:STORe:SNP:TYPE:S3P <numeric1>, <numeric2>, <numeric3>                                                                                                                                                                                                                                                                            | MMEMory:STORe:TRACe:PORTs                                                                                                    |
| MMEMory:STORe:SNP:TYPE:S4P <numeric3>, <numeric2>, <numeric3>, <numeric4>                                                                                                                                                                                                                                                                | MMEMory:STORe:TRACe:PORTs                                                                                                    |
| MMEMory:STORe:STYPe {STATe CSTate DSTate CDSTate}                                                                                                                                                                                                                                                                                        | MMEMory:STORe:STATe<br>Always saves measurement conditions and calibration state (CSTate), regardless of what you set it to. |
| SENSe{1...4}:AVERAge:CLEAr                                                                                                                                                                                                                                                                                                               | [SENSe<Ch>:]AVERAge:CLEAr                                                                                                    |
| SENSe{1...4}:AVERAge:COUNT <numeric>                                                                                                                                                                                                                                                                                                     | [SENSe<Ch>:]AVERAge:COUNT                                                                                                    |
| SENSe{1...4}:AVERAge[:STATe] {ON OFF 1 0}                                                                                                                                                                                                                                                                                                | [SENSe<Ch>:]AVERAge[:STATe]                                                                                                  |
| SENSe{1...4}:BWIDth[:RESolution] <bandwidth>                                                                                                                                                                                                                                                                                             | [SENSe<Ch>:]BWIDth[:RESolution]                                                                                              |
| SENSe{1...4}:CORRection:COLLect[:ACQuire]:LOAD <numeric><br>SENSe{1...4}:CORRection:COLLect[:ACQuire]:OPEN <numeric><br>SENSe{1...4}:CORRection:COLLect[:ACQuire]:SHORT <numeric><br>SENSe{1...4}:CORRection:COLLect[:ACQuire]:ISOLation <numeric1>, <numeric2><br>SENSe{1...4}:CORRection:COLLect[:ACQuire]:THRU <numeric1>, <numeric2> | [SENSe<Ch>:]CORRection:COLLect[:ACQuire]:SElected                                                                            |
| SENSe{1..4}:CORRection:COLLect:CKIT[:SElect] <integer>                                                                                                                                                                                                                                                                                   | [SENSe:]CORRection:CKIT:SElect                                                                                               |
| SENSe{1...4}:CORRection:COLLect:ECAL:ISOLation[:STATe] {OFF 0}                                                                                                                                                                                                                                                                           | None (no action)                                                                                                             |
| SENSe{1..4}:CORRection:COLLect:ECAL:PATH <EcalPort>, <VnaPort>                                                                                                                                                                                                                                                                           | [SENSe<Ch>:]CORRection:COLLect:AUTO:PORTs                                                                                    |
| SENSe{1...4}:CORRection:COLLect:ECAL:SOLT1 <numeric><br>SENSe{1...4}:CORRection:COLLect:ECAL:SOLT2 <numeric1>, <numeric2><br>SENSe{1...4}:CORRection:COLLect:ECAL:SOLT3 <numeric1>, <numeric2>, <numeric3><br>SENSe{1...4}:CORRection:COLLect:ECAL:SOLT4 1,2,3,4                                                                         | [SENSe<Ch>:]CORRection:COLLect:AUTO:TYPE                                                                                     |
| SENSe{1...4}:CORRection:COLLect:ECAL:UTHR[:STATe] {OFF 0}                                                                                                                                                                                                                                                                                |                                                                                                                              |

## ENA Emulation Commands

| ENA Emulation Command                                                                                                                                                                                                                                                                                                                                                                                                                                                                                                                                                                      | R&S ZND Default Parser Command                            |
|--------------------------------------------------------------------------------------------------------------------------------------------------------------------------------------------------------------------------------------------------------------------------------------------------------------------------------------------------------------------------------------------------------------------------------------------------------------------------------------------------------------------------------------------------------------------------------------------|-----------------------------------------------------------|
| SENSe<ch>:CORRection:COLLect:GUI-Ded:CKIT:PORT<pt>:CATalog?                                                                                                                                                                                                                                                                                                                                                                                                                                                                                                                                | [SENSe:]CORRection:CKIT:CATalog?                          |
| SENSe{1...4}:CORRection:COLLect:MEtHod[:RESPOnse]:OPEN <numeric><br>SENSe{1...4}:CORRection:COLLect:MEtHod[:RESPOnse]:SHORt <numeric><br>SENSe{1...4}:CORRection:COLLect:MEtHod:SOLT1 <numeric><br>SENSe{1...4}:CORRection:COLLect:MEtHod:SOLT2 <numeric1>, <numeric2><br>SENSe{1...4}:CORRection:COLLect:MEtHod:SOLT3 <numeric1>, <numeric2>, <numeric3><br>SENSe{1...4}:CORRection:COLLect:MEtHod:SOLT4 1,2,3,4<br>SENSe{1...4}:CORRection:COLLect:MEtHod[:RESPOnse]:THRU <numeric1>, <numeric2><br>SENSe{1...4}:CORRection:COLLect:MEtHod:TYPE?<br>SENSe{1...4}:CORRection:TYPE{1...4}? | [SENSe<Ch>:]CORRection:COLLect:MEtHod:DEFine              |
| SENSe{1...4}:CORRection:COLLect:SAVE                                                                                                                                                                                                                                                                                                                                                                                                                                                                                                                                                       | [SENSe<Ch>:]CORRection:COLLect:SAVE[:DUMMy]               |
| SENSe{1..4}:CORRection:COLLect:UTHRU[:STATe]{OFF 0}                                                                                                                                                                                                                                                                                                                                                                                                                                                                                                                                        |                                                           |
| SENSe<Ch>:CORRection:EXTension[:STATe]{ON OFF 1 0}                                                                                                                                                                                                                                                                                                                                                                                                                                                                                                                                         | [SENSe<Ch>:]CORRection:OFFSet<PhyPt>:COMPensation[:STATe] |
| SENSe{1...4}:CORRection:EXTension:PORT{[1] 2 3 4}:TIME <numeric>                                                                                                                                                                                                                                                                                                                                                                                                                                                                                                                           | [SENSe<Ch>:]CORRection:EDELay<PhyPt>[:TIME]               |
| SENSe{1...4}:CORRection:STATe {ON OFF 1 0}                                                                                                                                                                                                                                                                                                                                                                                                                                                                                                                                                 | [SENSe<Ch>:]CORRection[:STATe]                            |
| SENSe{1...4}:FREQuency:CENTer <numeric>                                                                                                                                                                                                                                                                                                                                                                                                                                                                                                                                                    | [SENSe<Ch>:]FREQuency:CENTer                              |
| SENSe{1...4}:FREQuency:DATA?                                                                                                                                                                                                                                                                                                                                                                                                                                                                                                                                                               | CALCulate<Chn>:DATA:STIMulus?                             |
| SENSe{1...4}:FREQuency:SPAN <numeric>                                                                                                                                                                                                                                                                                                                                                                                                                                                                                                                                                      | [SENSe<Ch>:]FREQuency:SPAN                                |
| SENSe{1...4}:FREQuency:STARt <numeric>                                                                                                                                                                                                                                                                                                                                                                                                                                                                                                                                                     | [SENSe<Ch>:]FREQuency:STARt                               |
| SENSe{1...4}:FREQuency:STOP <numeric>                                                                                                                                                                                                                                                                                                                                                                                                                                                                                                                                                      | [SENSe<Ch>:]FREQuency:STOP                                |
| SENSe{1...4}:ROSCillator:SOURce?                                                                                                                                                                                                                                                                                                                                                                                                                                                                                                                                                           | [SENSe<Ch>:]ROSCillator[:SOURce]                          |
| SENSe{1...4}:SEGment:SWEep:POINts?                                                                                                                                                                                                                                                                                                                                                                                                                                                                                                                                                         | [SENSe<Ch>:]SEGment<Seg>:SWEep:POINts                     |
| SENSe{1...4}:SEGment:SWEep:TIME?                                                                                                                                                                                                                                                                                                                                                                                                                                                                                                                                                           | [SENSe<Ch>:]SEGment<Seg>:SWEep:TIME                       |
| SENSe{1...4}:SEGment:DATA<br>5,<mode>,<ifbw>,<pow>,<del>,<time>,<segm>,<star 1>,<stop 1>,<nop 1>,<ifbw 1>,<pow 1>,<del 1>,<time 1>,<...>                                                                                                                                                                                                                                                                                                                                                                                                                                                   |                                                           |
| SENSe{1...4}:SWEep:DELay <numeric>                                                                                                                                                                                                                                                                                                                                                                                                                                                                                                                                                         | [SENSe<Ch>:]SWEep:DWELL                                   |

## ENA Emulation Commands

| ENA Emulation Command                                                                                   | R&S ZND Default Parser Command                                           |
|---------------------------------------------------------------------------------------------------------|--------------------------------------------------------------------------|
| SENSe{1...4}:SWEep:MOD CONTInuous   HOLD   SINGle<br>SENSe{1...4}:SWEep:MODE CONTInuous   HOLD   SINGle |                                                                          |
| SENSe{1...4}:SWEep:POINts <numeric>                                                                     | [SENSe<Ch>:]SWEep:POINts                                                 |
| SENSe{1...4}:SWEep:TIME[:DATA] <numeric>                                                                | [SENSe<Ch>:]SWEep:TIME                                                   |
| SENSe{1...4}:SWEep:TIME:AUTO {ON OFF 1 0}                                                               | [SENSe<Ch>:]SWEep:TIME:AUTO                                              |
| SENSe{1...4}:SWEep:TYPE {LINear SEGment}                                                                | [SENSe<Ch>:]SWEep:TYPE                                                   |
| SERvice:CHANnel:COUNT?                                                                                  | n.a. (no limit)                                                          |
| SERvice:CHANnel:TRACe:COUNT?                                                                            | n.a. (no limit)                                                          |
| SOURce{1...4}:POWer[:LEVel][:IMMediate][:AMPLitude] <numeric>                                           | SOURce<Ch>:POWer<PhyPt>[:LEVel][:IMMediate][:AMPLitude]                  |
| SOURce<ch>:POWer<pt>:CORRection[:STATe] {ON OFF 1 0}                                                    | SOURce<Ch>:POWer<PhyPt>:CORRection:STATe                                 |
| SOURce<ch>:POWer<pt>:CORRection:COLLect:AVERAge[:COUNT] <numeric>                                       | SOURce<Ch>:POWer<PhyPt>:CORRection:COLLect:AVERAge[:COUNT]               |
| SOURce:POWer<pt>:CORRection:COLLect:AVERAge:NTOLerance <numeric>                                        | SOURce<Ch>:POWer<PhyPt>:CORRection:COLLect:AVERAge:NTOLerance            |
| SOURce<ch>:POWer<pt>:CORRection:COLLect:SAVE [<RREC>]                                                   | n.a. (instrument automatically applies calibration after it is complete) |
| SOURce{1..4}:POWer:PORT:COUple {ON 1}                                                                   |                                                                          |
| STATus:OPERation:CONDition?                                                                             | STATus:QUEStionable:CONDition?                                           |
| STATus:OPERation:ENABle <numeric>                                                                       | STATus:QUEStionable:ENABle                                               |
| STATus:OPERation[:EVENT]?                                                                               | STATus:QUEStionable[:EVENT]?                                             |
| STATus:QUEStionable:NTRansition <numeric>                                                               | STATus:QUEStionable:NTRansition                                          |
| STATus:QUEStionable:PTRansition <numeric>                                                               | STATus:QUEStionable:LIMit<Lev>:PTRansition                               |
| STATus:QUEStionable:LIMit:CONDition?                                                                    | STATus:QUEStionable:LIMit<Lev>:CONDition?                                |
| STATus:QUEStionable:LIMit:ENABle <numeric>                                                              | STATus:QUEStionable:LIMit<Lev>:ENABle                                    |
| STATus:QUEStionable:LIMit[:EVENT]?                                                                      | STATus:QUEStionable:LIMit<Lev>[:EVENT]?                                  |
| STATus:QUEStionable:LIMit:NTRansition <numeric>                                                         | STATus:QUEStionable:LIMit<Lev>:NTRansition                               |
| STATus:QUEStionable:LIMit:PTRansition <numeric>                                                         | STATus:QUEStionable:LIMit<Lev>:PTRansition                               |
| SYSTem:BEEPer:WARning:STATe {ON OFF 1 0}                                                                | CALCulate<Chn>:LIMit:SOUND[:STATe]                                       |
| SYSTem:KLOCK:kBD {ON OFF 1 0}                                                                           | SYSTem:KLOCK                                                             |

| ENA Emulation Command                                    | R&S ZND Default Parser Command |
|----------------------------------------------------------|--------------------------------|
| TRIGger[:SEQuence]:SOURce {INTernal EXTernal MANual BUS} | TRIGger<Ch>[:SEQuence]:SOURce  |
|                                                          |                                |
|                                                          |                                |
|                                                          |                                |
|                                                          |                                |
|                                                          |                                |
|                                                          |                                |
|                                                          |                                |
|                                                          |                                |
|                                                          |                                |

# Glossary: Frequently Used Terms

## A

**Active channel:** Channel belonging to the active trace. The active channel is highlighted in the channel list below the diagram. The active channel is not relevant in remote control where each channel can contain an active trace.

**Active marker:** Marker that can be changed using the settings of the Marker menu (Delta Mode, Ref. Mkr -> Mkr, Mkr Format). The active marker is also used for the Marker Functions. It appears in the diagram with an enlarged marker symbol and font size and with a dot placed in front of the marker line in the info field.

**Active menu:** The menu containing the last executed command. If the softkey bar is displayed (Display - Config./View - Softkey Labels on), then the active menu is indicated on top of the softkey bar.

**Active trace (manual control):** Trace that is selected to apply the settings in the Trace menu. The active trace is highlighted in the trace list of the active diagram area. It can be different from the active trace in remote control.

**Active trace (remote control):** One trace of each channel that has been selected as the active trace (`CALCulate<Ch>:PARAMeter:SElect <trace name>`). Many commands (e.g. `TRACE . . .`) act on the active trace. It can be different from the active trace in manual control.

## C

**Cal pool:** The cal pool is a collection of correction data sets (cal groups) that the analyzer stores in a common directory. Cal groups in the pool can be applied to different channels and recall sets.

**Calibration:** The process of removing systematic errors from the measurement (system error correction). See also TOSM, TOM, TRM, TRL, TNA...

**Calibration kit:** Set of physical calibration standards for a particular connector family.

**Calibration standard:** Physical device that has a known or predictable magnitude and phase response within a given frequency range. Calibration standards are grouped into several types (open, through, match,...) corresponding to the different input quantities for the analyzer's error models.

**Calibration unit:** Integrated solution for automatic calibration of multiple ports (accessories R&S ZV-Zxx, R&S ZN-Z5x and R&S ZN-Z15x). The unit contains calibration standards that are electronically switched when a calibration is performed.

**Channel:** A channel contains hardware-related settings to specify how the network analyzer collects data. Each channel is stored in an independent data set. The channel

settings complement the definitions of the Trace menu; they apply to all traces assigned to the channel.

**Compression point:** The x-dB compression point of an S-parameter or ratio is the stimulus signal level where the magnitude of the measured quantity has dropped by x dB compared to its value at small stimulus signal levels (small-signal value).

**Confirmation dialog box:** Standard dialog box that pops up to display an error message or a warning. The current action can be either continued (OK) or canceled (Cancel) on closing the dialog box.

**Crosstalk:** The occurrence of a signal at the receive port of the analyzer which did not travel through the test setup and the DUT but leaks through other internal paths. Crosstalk causes an isolation error in the measurement which can be corrected by means of a calibration.

**CW frequency:** Continuous Wave frequency; fixed stimulus frequency used in Power, CW Time and CW Mode sweeps.

## D

**Data trace:** Trace filled with measurement data and updated after each sweep (dynamic trace).

**Diagram area:** Rectangular portion of the screen used to display traces. Diagram areas are arranged in windows; they are independent of trace and channel settings.

**Directivity error:** Measurement error caused by a coupler or bridge in the analyzer's source port causing part of the generated signal to leak through the forward path into the receive path instead of being transmitted towards the DUT. The directivity error can be corrected by means of a full one port calibration or one of the two-port calibration methods (except normalization).

**Discrete marker:** The stimulus value of a discrete marker always coincides with a sweep point so that the marker does not show interpolated measurement values.

**DUT:** Device under test; generic term for any electrical device or circuit which the vector network analyzer can measure. Typical DUTs are filters, amplifiers, or mixers.

## E

**Excursion:** Difference between the response values at a local maximum (minimum) of the trace and at the two closest local minima (maxima) to the left and to the right.

**Extrapolation:** Calculation of a numeric value for a new sweep point outside the original sweep range from the numeric values of the existing sweep points. The analyzer can extrapolate calibration data, transmission coefficients etc. to extend the sweep range. If not otherwise stated, the numeric value of the first (last) sweep point is



assigned to all new points below (above) the original sweep range. See also --> interpolation.

## F

**Forward:** A measurement on a two-port DUT is said to be in forward direction if the source signal (stimulus) is applied to port 1 of the DUT.

## H

**Harmonic:** Integer multiple of the fundamental frequency. The fundamental is the first harmonic, the nth harmonic is n times the frequency of the fundamental.

**Harmonic distortion:** The production of harmonic frequencies (harmonics) by an electronic system when a signal is applied at the input.

**Harmonic grid:** A set of equidistant frequency points  $f_i$  ( $i = 1 \dots n$ ) with spacing  $\Delta(f)$  and the additional condition that  $f_1 = \Delta(f)$ . A harmonic grid is required for low pass time domain transforms.

## I

**Intercept point:** Fictitious lower-tone DUT input/output level where the intermodulation suppression (-->) for a given intermodulation product reaches 0 dB.

**Intermodulation measurement:** Measurement where the DUT is supplied with two RF signals of equal power but different frequencies termed the upper and lower tone. The analyzer measures the frequency-converting behavior of the DUT (--> intermodulation product).

**Intermodulation product:** Special type of emissions of a nonlinear DUT that is supplied with a two-tone RF signal (--> intermodulation measurement). The intermodulation products occur at frequencies which correspond to sums and differences of the upper and lower tone frequencies and their integer multiples.

**Intermodulation suppression:** The ratio of the power of an --> intermodulation product to the power of the lower tone fundamental wave.

**Interpolation:** Calculation of a numeric value for a specific sweep point from the numeric values of the adjacent points. The analyzer can interpolate calibration data, transmission coefficients etc. to account for a modified set of sweep points. If not otherwise stated, linear interpolation is used. See also --> extrapolation.

**Isolation error:** Measurement error caused by a crosstalk between the source and receive port of the analyzer.

**L**

**Limit check:** Comparison of the measurement results with the limit lines and display of a pass/fail indication. An acoustic warning can be generated in addition if a limit is exceeded.

**Limit line:** A limit line is a set of data to specify the allowed range for some or all points of a trace. Typically, limit lines are used to check whether a DUT conforms to the rated specifications (conformance testing).

**Load match error:** Measurement error caused by a mismatch of the analyzer's receive (load) port causing part of the signal transmitted through the DUT to be reflected off the receive port so that it is not measured there. The load match error can be corrected by means of a two-port calibration (except normalization).

**M**

**Marker:** Tool for selecting points on the trace and for numerical readout of measured data. A marker is displayed with a symbol (a triangle, a crossbar or a line) on the trace; its coordinates are shown in the marker info field.

**Mathematical trace:** Trace that is calculated according to a mathematical expression, e.g. the one defined in the Define Math dialog. The expression is a mathematical relation between constants and the data or memory traces of the active recall set.

**Measurement point:** Result of the measurement at a specified stimulus value (frequency/power/time).

**Measurement result:** Set of all measurement points acquired in a measurement (e.g. a sweep). The measurement result is displayed in a diagram area and forms a trace.

**Memory trace:** Trace that is associated to a data trace and stored in the memory. Data traces and the associated memory traces share the same channel and scale settings. Alternatively, memory traces can be imported from a file.

**Mixer:** Device that converts an RF signal at one frequency into a signal at another frequency. The frequency that is to be shifted is applied at the RF input and the frequency shifting signal (from a local oscillator, LO) is applied to the RF mixer's LO port, resulting in an output signal at the mixer's Intermediate Frequency (IF) port.

**P**

**Partial measurement:** Measurement at a specified stimulus value maintaining definite hardware settings. Depending on the measurement type, several partial measurements may be needed to obtain a measurement point. A full n-port S-parameter measurement requires n partial measurements with n different drive ports.

**Peak:** Local maximum or local minimum (dip) on the trace. In the Trace - Search menu, it is possible to define a minimum excursion that both types of peaks must have to be considered valid.

**R**

**Recall Set:** A recall set comprises a set of diagram areas with all displayed information that can be stored to a VNA recall set file (\*.znx | \*.znxml). Each recall set is displayed in an independent tab.

**Reflection tracking error:** Frequency-dependent variation of the ratio of the reflected wave to the reference wave at a test port when an ideal reflection coefficient (= 1) is measured. The reflection tracking error can be corrected by means of a reflection normalization or one of the more sophisticated calibration methods.

**Reverse:** A measurement on a two-port DUT is said to be in reverse direction if the source signal (stimulus) is applied to port 2 of the DUT.

**S**

**Source match error:** Measurement error caused by a mismatch of the analyzer's source port causing part of the signal reflected off the DUT to be reflected again off the source port so that it is not measured there. The source match error can be corrected by means of a full one-port calibration or a two-port calibration (except normalization).

**Stimulus value:** Value of the sweep variable (frequency/power/time/point number) where a measurement is taken. Also termed sweep point.

**Sweep:** Series of consecutive measurements taken at a specified sequence of stimulus values = series of consecutive measurement points.

**Sweep point:** Value of the sweep variable (stimulus value: frequency/power/time) where a measurement is taken.

**Sweep range:** Continuous range of the sweep variable (frequency/power/time) containing the sweep points where the analyzer takes measurements. In a Segmented Frequency sweep the sweep range can be composed of several parameter ranges or single points.

**Sweep segment:** Continuous frequency range or single frequency point where the analyzer measures at specified instrument settings (generator power, IF bandwidth etc.). In the Segmented Frequency sweep type the entire sweep range can be composed of several sweep segments.

**T**

**TNA:** A calibration type using a Through, a symmetric Network and an Attenuation standard. The properties of the Network and the Attenuation don't have to be known exactly. Like TRL and TRM, TNA is especially useful for DUTs in planar line technology.

**TOM:** A calibration type using three fully known standards (Through, Open, Match), recommended for 2-port measurements on coaxial systems.

**Topology:** Assignment of the physical ports of the VNA to the logical ports used for the measurement of mixed mode S-parameters (balance-unbalance conversion).

**TOSM:** A calibration type using a Through plus the one-port standards Open, Short, Match, to be connected to each calibrated port. Classical 12-term error model, also referred to as SOLT. See also UOSM.

**TRL:** A calibration type using the two-port standards Through and Line, which are both assumed to be ideally matched. Beyond that, the through must be lossless, and its length must be exactly known. Especially useful for DUTs in planar line technology.

**TRM:** A calibration type which requires a low-reflection, low-loss Through standard with an electrical length that may be different from zero, a Reflect, and a Match. Especially useful for DUTs in test fixtures.

**TSM:** A calibration type using three fully known standards (Through, Short, Match), recommended for 2-port measurements on coaxial systems.

## U

**UOSM:** A variant of TOSM calibration using an unknown but reciprocal Through standard. Especially for port combinations with different connector types.

## V

**VNA:** (Vector) Network Analyzer, in particular the R&S ZND.

## List of commands

|                                                                   |      |
|-------------------------------------------------------------------|------|
| [SENSe:]CDLL:ADD.....                                             | 889  |
| [SENSe:]CDLL:LIST:TASK?.....                                      | 890  |
| [SENSe:]CDLL:LIST?.....                                           | 889  |
| [SENSe:]CDLL:REMove.....                                          | 889  |
| [SENSe:]CORRection:CKIT:<ConnType>:LSElect.....                   | 906  |
| [SENSe:]CORRection:CKIT:<ConnType>:SElect.....                    | 899  |
| [SENSe:]CORRection:CKIT:<OnePortStandardType>:WLABel:SDATa?.....  | 907  |
| [SENSe:]CORRection:CKIT:<StandardType>.....                       | 900  |
| [SENSe:]CORRection:CKIT:<StandardType>:WLABel.....                | 907  |
| [SENSe:]CORRection:CKIT:<TwoPortStandard>:WLABel:SDATa?.....      | 908  |
| [SENSe:]CORRection:CKIT:CATalog?.....                             | 895  |
| [SENSe:]CORRection:CKIT:DELeTe.....                               | 896  |
| [SENSe:]CORRection:CKIT:DMODE.....                                | 896  |
| [SENSe:]CORRection:CKIT:INSTall.....                              | 1098 |
| [SENSe:]CORRection:CKIT:LABel.....                                | 897  |
| [SENSe:]CORRection:CKIT:LCATalog?.....                            | 904  |
| [SENSe:]CORRection:CKIT:LDELeTe.....                              | 904  |
| [SENSe:]CORRection:CKIT:LLABel.....                               | 904  |
| [SENSe:]CORRection:CKIT:LSElect.....                              | 905  |
| [SENSe:]CORRection:CKIT:SElect.....                               | 897  |
| [SENSe:]CORRection:CKIT:STANdard:CATalog?.....                    | 898  |
| [SENSe:]CORRection:CKIT:STANdard:DATA?.....                       | 898  |
| [SENSe:]CORRection:CKIT:STANdard:LCATalog?.....                   | 906  |
| [SENSe:]CORRection:COLLect:AUTO:CKIT.....                         | 910  |
| [SENSe:]CORRection:COLLect:AUTO:CKIT:PASSword.....                | 911  |
| [SENSe:]CORRection:COLLect:AUTO:CKIT:PORTs.....                   | 912  |
| [SENSe:]CORRection:COLLect:AUTO:CKIT:PORTs:ADD.....               | 913  |
| [SENSe:]CORRection:COLLect:AUTO:MCONnect.....                     | 913  |
| [SENSe:]CORRection:COLLect:AUTO:PORTs:CONNection?.....            | 914  |
| [SENSe:]CORRection:COLLect:AVERAge.....                           | 914  |
| [SENSe:]CORRection:COLLect:CHANnels:ALL.....                      | 914  |
| [SENSe:]CORRection:COLLect:CHANnels:MCTypes.....                  | 915  |
| [SENSe:]CORRection:COLLect:FIXTure:LMPParameter:LOSS[:STATe]..... | 917  |
| [SENSe:]CORRection:COLLect:FIXTure:LMPParameter[:STATe].....      | 917  |
| [SENSe:]CORRection:EDELay:VNETwork.....                           | 946  |
| [SENSe:]ROSCillator:EXTernal:FREQuency.....                       | 967  |
| [SENSe:]SWEep:COUNt:ALL.....                                      | 982  |
| [SENSe<Ch>:]AVERAge:CLEar.....                                    | 887  |
| [SENSe<Ch>:]AVERAge:COUNt.....                                    | 887  |
| [SENSe<Ch>:]AVERAge:MODE.....                                     | 887  |
| [SENSe<Ch>:]AVERAge[:STATe].....                                  | 886  |
| [SENSe<Ch>:]BANDwidth[:RESolution].....                           | 888  |
| [SENSe<Ch>:]BWIDth[:RESolution].....                              | 888  |
| [SENSe<Ch>:]CDLL:PERManent:ADDitional.....                        | 890  |
| [SENSe<Ch>:]CDLL:PERManent:TASK.....                              | 890  |
| [SENSe<Ch>:]CDLL:PERManent[:STATe].....                           | 891  |
| [SENSe<Ch>:]CDLL:TASK:ADDRess.....                                | 891  |

|                                                                     |      |
|---------------------------------------------------------------------|------|
| [SENSe<Ch>:]CDLL[:STATE]                                            | 891  |
| [SENSe<Ch>:]CORRection:CDATA                                        | 892  |
| [SENSe<Ch>:]CORRection:CKIT:<ConnType>:<StandardType>               | 1097 |
| [SENSe<Ch>:]CORRection:COLLect:AUTO                                 | 920  |
| [SENSe<Ch>:]CORRection:COLLect:AUTO:ASSignment:ALL:COUNT?           | 954  |
| [SENSe<Ch>:]CORRection:COLLect:AUTO:ASSignment:COUNT?               | 955  |
| [SENSe<Ch>:]CORRection:COLLect:AUTO:ASSignment:DEFine:DEFault       | 955  |
| [SENSe<Ch>:]CORRection:COLLect:AUTO:ASSignment:DEFine:TPORt:DEFault | 956  |
| [SENSe<Ch>:]CORRection:COLLect:AUTO:ASSignment:DELeTe:ALL           | 956  |
| [SENSe<Ch>:]CORRection:COLLect:AUTO:ASSignment<Asg>:ACQuire         | 956  |
| [SENSe<Ch>:]CORRection:COLLect:AUTO:ASSignment<Asg>:DEFine          | 957  |
| [SENSe<Ch>:]CORRection:COLLect:AUTO:ASSignment<Asg>:DEFine:TPORt    | 958  |
| [SENSe<Ch>:]CORRection:COLLect:AUTO:CONFigure                       | 921  |
| [SENSe<Ch>:]CORRection:COLLect:AUTO:CPOrt                           | 922  |
| [SENSe<Ch>:]CORRection:COLLect:AUTO:POrtS                           | 922  |
| [SENSe<Ch>:]CORRection:COLLect:AUTO:POrtS:TYPE                      | 923  |
| [SENSe<Ch>:]CORRection:COLLect:AUTO:SAVE                            | 959  |
| [SENSe<Ch>:]CORRection:COLLect:AUTO:TYPE                            | 925  |
| [SENSe<Ch>:]CORRection:COLLect:CKIT:INSTAll                         | 926  |
| [SENSe<Ch>:]CORRection:COLLect:CKIT:LOAD                            | 927  |
| [SENSe<Ch>:]CORRection:COLLect:CKIT:POrt<PhyPt>?                    | 927  |
| [SENSe<Ch>:]CORRection:COLLect:CONNectiON:GENDeRS                   | 928  |
| [SENSe<Ch>:]CORRection:COLLect:CONNectiON:POrtS                     | 929  |
| [SENSe<Ch>:]CORRection:COLLect:CONNectiON<PhyPt>                    | 927  |
| [SENSe<Ch>:]CORRection:COLLect:DELeTe                               | 929  |
| [SENSe<Ch>:]CORRection:COLLect:DETeCtor                             | 917  |
| [SENSe<Ch>:]CORRection:COLLect:DISCard                              | 930  |
| [SENSe<Ch>:]CORRection:COLLect:FIXTure:EXPOrt                       | 931  |
| [SENSe<Ch>:]CORRection:COLLect:FIXTure:IMPOrt                       | 931  |
| [SENSe<Ch>:]CORRection:COLLect:FIXTure:SAVE                         | 932  |
| [SENSe<Ch>:]CORRection:COLLect:FIXTure:STARt                        | 933  |
| [SENSe<Ch>:]CORRection:COLLect:FIXTure[:ACQuire]                    | 930  |
| [SENSe<Ch>:]CORRection:COLLect:LOAD:SELeCted                        | 933  |
| [SENSe<Ch>:]CORRection:COLLect:METHod                               | 1099 |
| [SENSe<Ch>:]CORRection:COLLect:METHod:DEFine                        | 934  |
| [SENSe<Ch>:]CORRection:COLLect:SAVE:DEFault                         | 1100 |
| [SENSe<Ch>:]CORRection:COLLect:SAVE:SELeCted:DEFault                | 936  |
| [SENSe<Ch>:]CORRection:COLLect:SAVE:SELeCted[:DUMMy]                | 937  |
| [SENSe<Ch>:]CORRection:COLLect:SAVE[:DUMMy]                         | 1101 |
| [SENSe<Ch>:]CORRection:COLLect:SCONNectiON<PhyPt>                   | 938  |
| [SENSe<Ch>:]CORRection:COLLect[:ACQuire]                            | 1098 |
| [SENSe<Ch>:]CORRection:COLLect[:ACQuire]:SELeCted                   | 918  |
| [SENSe<Ch>:]CORRection:CONNectiON                                   | 938  |
| [SENSe<Ch>:]CORRection:CONNectiON:CATAlOG?                          | 939  |
| [SENSe<Ch>:]CORRection:CONNectiON:DELeTe                            | 940  |
| [SENSe<Ch>:]CORRection:DATA                                         | 1102 |
| [SENSe<Ch>:]CORRection:DATA:PARAmeter:COUNT?                        | 943  |
| [SENSe<Ch>:]CORRection:DATA:PARAmeter<Sfk>?                         | 941  |
| [SENSe<Ch>:]CORRection:DATE?                                        | 943  |
| [SENSe<Ch>:]CORRection:DELeTe                                       | 936  |

|                                                                |      |
|----------------------------------------------------------------|------|
| [SENSe<Ch>:]CORRection:EDELay:AUTO.....                        | 944  |
| [SENSe<Ch>:]CORRection:EDELay<PhyPt>:DIElectric.....           | 944  |
| [SENSe<Ch>:]CORRection:EDELay<PhyPt>:DISTance.....             | 945  |
| [SENSe<Ch>:]CORRection:EDELay<PhyPt>:ELENgth.....              | 945  |
| [SENSe<Ch>:]CORRection:EDELay<PhyPt>[:TIME].....               | 946  |
| [SENSe<Ch>:]CORRection:EWAVE[:STATe].....                      | 947  |
| [SENSe<Ch>:]CORRection:LOSS:AUTO.....                          | 947  |
| [SENSe<Ch>:]CORRection:LOSS<PhyPt>.....                        | 947  |
| [SENSe<Ch>:]CORRection:LOSS<PhyPt>:FREQuency.....              | 948  |
| [SENSe<Ch>:]CORRection:LOSS<PhyPt>:OFFSet.....                 | 948  |
| [SENSe<Ch>:]CORRection:LOSS<PhyPt>:SECond.....                 | 947  |
| [SENSe<Ch>:]CORRection:LOSS<PhyPt>:SECond:FREQuency.....       | 948  |
| [SENSe<Ch>:]CORRection:LOSS<PhyPt>:SECond:STATe.....           | 948  |
| [SENSe<Ch>:]CORRection:OFFSet<PhyPt>:COMPensation[:STATe]..... | 949  |
| [SENSe<Ch>:]CORRection:OFFSet<PhyPt>:DFComp[:STATe]?.....      | 950  |
| [SENSe<Ch>:]CORRection:OFFSet<PhyPt>:MAGNitude.....            | 1104 |
| [SENSe<Ch>:]CORRection:OFFSet<PhyPt>[:STATe].....              | 949  |
| [SENSe<Ch>:]CORRection:PCAL.....                               | 950  |
| [SENSe<Ch>:]CORRection:POWEr:DATA.....                         | 951  |
| [SENSe<Ch>:]CORRection:POWEr<PhyPt>:ACQuire.....               | 952  |
| [SENSe<Ch>:]CORRection:POWEr<PhyPt>:AWAVE[:STATe].....         | 953  |
| [SENSe<Ch>:]CORRection:POWEr<PhyPt>[:STATe].....               | 951  |
| [SENSe<Ch>:]CORRection:SMATrix:CDATA.....                      | 894  |
| [SENSe<Ch>:]CORRection:SMATrix:CDATA:PORT<PhyPt>.....          | 894  |
| [SENSe<Ch>:]CORRection:STIMulus?.....                          | 954  |
| [SENSe<Ch>:]CORRection[:STATe].....                            | 918  |
| [SENSe<Ch>:]COUPle.....                                        | 960  |
| [SENSe<Ch>:]FREQuency:CENTer.....                              | 961  |
| [SENSe<Ch>:]FREQuency:FIXed.....                               | 961  |
| [SENSe<Ch>:]FREQuency:MODE.....                                | 1104 |
| [SENSe<Ch>:]FREQuency:SEGMENT:AXIS.....                        | 962  |
| [SENSe<Ch>:]FREQuency:SPAN.....                                | 962  |
| [SENSe<Ch>:]FREQuency:START.....                               | 963  |
| [SENSe<Ch>:]FREQuency:STOP.....                                | 963  |
| [SENSe<Ch>:]FREQuency[:CW].....                                | 961  |
| [SENSe<Ch>:]HARMonic:AUTO.....                                 | 964  |
| [SENSe<Ch>:]HARMonic?.....                                     | 964  |
| [SENSe<Ch>:]LPORT<LogPt>:ZCOMmon.....                          | 964  |
| [SENSe<Ch>:]LPORT<LogPt>:ZDEFault[:STATe].....                 | 965  |
| [SENSe<Ch>:]LPORT<LogPt>:ZDIFferent.....                       | 964  |
| [SENSe<Ch>:]PORT<PhyPt>:ZREFerence.....                        | 966  |
| [SENSe<Ch>:]ROSCillator[:SOURce].....                          | 967  |
| [SENSe<Ch>:]SEGMENT:COUNT?.....                                | 968  |
| [SENSe<Ch>:]SEGMENT<Seg>:ADD.....                              | 969  |
| [SENSe<Ch>:]SEGMENT<Seg>:BWIDth[:RESolution].....              | 969  |
| [SENSe<Ch>:]SEGMENT<Seg>:BWIDth[:RESolution]:CONTrol.....      | 970  |
| [SENSe<Ch>:]SEGMENT<Seg>:CLEar.....                            | 1105 |
| [SENSe<Ch>:]SEGMENT<Seg>:DEFine.....                           | 971  |
| [SENSe<Ch>:]SEGMENT<Seg>:DEFine:SElect.....                    | 972  |
| [SENSe<Ch>:]SEGMENT<Seg>:DELeTe:ALL.....                       | 973  |

|                                                              |      |
|--------------------------------------------------------------|------|
| [SENSe<Ch>:]SEGMENT<Seg>:DELEte[:DUMMy].....                 | 973  |
| [SENSe<Ch>:]SEGMENT<Seg>:FREQuency:CENTer?.....              | 974  |
| [SENSe<Ch>:]SEGMENT<Seg>:FREQuency:SPAN?.....                | 974  |
| [SENSe<Ch>:]SEGMENT<Seg>:FREQuency:START.....                | 974  |
| [SENSe<Ch>:]SEGMENT<Seg>:FREQuency:STOP.....                 | 974  |
| [SENSe<Ch>:]SEGMENT<Seg>:INSert.....                         | 975  |
| [SENSe<Ch>:]SEGMENT<Seg>:INSert:SElect.....                  | 977  |
| [SENSe<Ch>:]SEGMENT<Seg>:OVERlap.....                        | 1105 |
| [SENSe<Ch>:]SEGMENT<Seg>:POWER[:LEVel].....                  | 977  |
| [SENSe<Ch>:]SEGMENT<Seg>:POWER[:LEVel]:CONTRol.....          | 978  |
| [SENSe<Ch>:]SEGMENT<Seg>:SWEep:DWELI.....                    | 978  |
| [SENSe<Ch>:]SEGMENT<Seg>:SWEep:DWELI:CONTRol.....            | 979  |
| [SENSe<Ch>:]SEGMENT<Seg>:SWEep:POINTs.....                   | 980  |
| [SENSe<Ch>:]SEGMENT<Seg>:SWEep:TIME.....                     | 980  |
| [SENSe<Ch>:]SEGMENT<Seg>:SWEep:TIME:CONTRol.....             | 981  |
| [SENSe<Ch>:]SEGMENT<Seg>:SWEep:TIME:SUM?.....                | 982  |
| [SENSe<Ch>:]SEGMENT<Seg>[:STATe].....                        | 968  |
| [SENSe<Ch>:]SWEep:COUNT.....                                 | 983  |
| [SENSe<Ch>:]SWEep:DETEctor:TIME.....                         | 983  |
| [SENSe<Ch>:]SWEep:DWELI.....                                 | 984  |
| [SENSe<Ch>:]SWEep:DWELI:IPoint.....                          | 984  |
| [SENSe<Ch>:]SWEep:POINTs.....                                | 985  |
| [SENSe<Ch>:]SWEep:SPACing.....                               | 1105 |
| [SENSe<Ch>:]SWEep:STEP.....                                  | 985  |
| [SENSe<Ch>:]SWEep:TIME.....                                  | 986  |
| [SENSe<Ch>:]SWEep:TIME:AUTO.....                             | 987  |
| [SENSe<Ch>:]SWEep:TYPE.....                                  | 988  |
| [SENSe<Chn>:]CORREction:PSate?.....                          | 959  |
| [SENSe<Chn>:]CORREction:SSate?.....                          | 959  |
| [SENSe<Chn>:]FUNctIon[:ON].....                              | 1106 |
| [SENSe<Chn>:]SWEep:SRCPort.....                              | 989  |
| CALCulate:CALVAlidate:CHARacteriza.....                      | 598  |
| CALCulate:CALVAlidate:RESPonse:MAGNitude:LOWer.....          | 599  |
| CALCulate:CALVAlidate:RESPonse:MAGNitude:UPPer.....          | 599  |
| CALCulate:CALVAlidate:RESPonse:PHASe:LOWer.....              | 599  |
| CALCulate:CALVAlidate:RESPonse:PHASe:UPPer.....              | 599  |
| CALCulate:CALVAlidate:RUN.....                               | 599  |
| CALCulate:CALVAlidate:STANdard.....                          | 599  |
| CALCulate:CLIMits:FAIL?.....                                 | 598  |
| CALCulate:DATA:ALL?.....                                     | 600  |
| CALCulate:DATA:DALL?.....                                    | 601  |
| CALCulate:DATA:TRACe.....                                    | 601  |
| CALCulate:FILTer[:GATE]:TIME:AOFFset.....                    | 610  |
| CALCulate:FMODEl:DELT:M1L:DIFFmode.....                      | 635  |
| CALCulate:FMODEl:DELT:MEASurement.....                       | 635  |
| CALCulate:FMODEl:DELT:TDR.....                               | 638  |
| CALCulate:FMODEl:DELT<Ph_pt>:FREQuencies:CURRent:COUNT?..... | 630  |
| CALCulate:FMODEl:DELT<Ph_pt>:FREQuencies:CURRent?.....       | 629  |
| CALCulate:FMODEl:DELT<Ph_pt>:FREQuencies:DEFault:COUNT?..... | 630  |
| CALCulate:FMODEl:DELT<Ph_pt>:FREQuencies:DEFault?.....       | 630  |



|                                                                |     |
|----------------------------------------------------------------|-----|
| CALCulate:FModel:DELT<Ph_pt>:FREQuencies:USEDefault.....       | 631 |
| CALCulate:FModel:DELT<Ph_pt>:FREQuencies:USER:ADD.....         | 632 |
| CALCulate:FModel:DELT<Ph_pt>:FREQuencies:USER:COUNT?.....      | 631 |
| CALCulate:FModel:DELT<Ph_pt>:FREQuencies:USER:DELeTe.....      | 632 |
| CALCulate:FModel:DELT<Ph_pt>:FREQuencies:USER:DELeTe:ALL.....  | 632 |
| CALCulate:FModel:DELT<Ph_pt>:FREQuencies:USER?.....            | 631 |
| CALCulate:FModel:DELT<Ph_pt>:M1L:CAChE:CLEar:ALL.....          | 632 |
| CALCulate:FModel:DELT<Ph_pt>:M1L:CAChE:CLEar:SELeCted.....     | 633 |
| CALCulate:FModel:DELT<Ph_pt>:M1L:FILeName.....                 | 633 |
| CALCulate:FModel:DELT<Ph_pt>:M1L:LENGth.....                   | 633 |
| CALCulate:FModel:DELT<Ph_pt>:M1L:MEASure.....                  | 634 |
| CALCulate:FModel:DELT<Ph_pt>:M1L[:STATe].....                  | 634 |
| CALCulate:FModel:DELT<Ph_pt>:M2L:FILeName.....                 | 633 |
| CALCulate:FModel:DELT<Ph_pt>:M2L:LENGth.....                   | 633 |
| CALCulate:FModel:DELT<Ph_pt>:M2L:MEASure.....                  | 634 |
| CALCulate:FModel:DELT<Ph_pt>:M2L[:STATe].....                  | 634 |
| CALCulate:FModel:DELT<Ph_pt>:M3L:FILeName.....                 | 633 |
| CALCulate:FModel:DELT<Ph_pt>:M3L:LENGth.....                   | 633 |
| CALCulate:FModel:DELT<Ph_pt>:M3L:MEASure.....                  | 634 |
| CALCulate:FModel:DELT<Ph_pt>:M3L[:STATe].....                  | 634 |
| CALCulate:FModel:DELT<Ph_pt>:METHod.....                       | 635 |
| CALCulate:FModel:DELT<Ph_pt>:PORDer.....                       | 636 |
| CALCulate:FModel:DELT<Ph_pt>:RUN.....                          | 636 |
| CALCulate:FModel:DELT<Ph_pt>:SWEep:CONTRol.....                | 636 |
| CALCulate:FModel:DELT<Ph_pt>:SWEep:CONTRol:IFBW?.....          | 637 |
| CALCulate:FModel:DELT<Ph_pt>:SWEep:CONTRol:STEP?.....          | 637 |
| CALCulate:FModel:DELT<Ph_pt>:SWEep:FREQuency:MAXimum.....      | 637 |
| CALCulate:FModel:DELT<Ph_pt>:SWEep:FREQuency:MINimum.....      | 637 |
| CALCulate:FModel:DELT<Ph_pt>:TCONfig.....                      | 638 |
| CALCulate:FModel:EZD<Ph_pt>:COUPon:MEASure.....                | 639 |
| CALCulate:FModel:EZD<Ph_pt>:COUPon:MEASure:FILeName.....       | 639 |
| CALCulate:FModel:EZD<Ph_pt>:COUPon[:STATe].....                | 639 |
| CALCulate:FModel:EZD<Ph_pt>:DCEXtrapolat.....                  | 640 |
| CALCulate:FModel:EZD<Ph_pt>:DUT:MEASure.....                   | 640 |
| CALCulate:FModel:EZD<Ph_pt>:DUT:MEASure:FILeName.....          | 640 |
| CALCulate:FModel:EZD<Ph_pt>:DUT[:STATe].....                   | 640 |
| CALCulate:FModel:EZD<Ph_pt>:GENerate:SIDE<1 2>.....            | 640 |
| CALCulate:FModel:EZD<Ph_pt>:IMPedance.....                     | 641 |
| CALCulate:FModel:EZD<Ph_pt>:IMPedance:BWIDlimit.....           | 641 |
| CALCulate:FModel:EZD<Ph_pt>:IMPedance:REFeRence.....           | 641 |
| CALCulate:FModel:EZD<Ph_pt>:RUN:RUN.....                       | 641 |
| CALCulate:FModel:EZD<Ph_pt>:RUN[:STATe].....                   | 642 |
| CALCulate:FModel:ISD<Ph_pt>:ATTenuation:BEHavior.....          | 616 |
| CALCulate:FModel:ISD<Ph_pt>:COUPon:MEASure.....                | 616 |
| CALCulate:FModel:ISD<Ph_pt>:COUPon:MEASure:FILeName.....       | 617 |
| CALCulate:FModel:ISD<Ph_pt>:COUPon:MEASure:OPEN.....           | 617 |
| CALCulate:FModel:ISD<Ph_pt>:COUPon:MEASure:OPEN:FILeName.....  | 617 |
| CALCulate:FModel:ISD<Ph_pt>:COUPon:MEASure:SHORT.....          | 617 |
| CALCulate:FModel:ISD<Ph_pt>:COUPon:MEASure:SHORT:FILeName..... | 618 |
| CALCulate:FModel:ISD<Ph_pt>:COUPon:TYPE.....                   | 618 |

|                                                          |     |
|----------------------------------------------------------|-----|
| CALCulate:FModel:ISD<Ph_pt>:COUPon[:STATe].....          | 618 |
| CALCulate:FModel:ISD<Ph_pt>:DCEXtrapolat.....            | 619 |
| CALCulate:FModel:ISD<Ph_pt>:DUT:MEASure.....             | 619 |
| CALCulate:FModel:ISD<Ph_pt>:DUT:MEASure:FILEname.....    | 619 |
| CALCulate:FModel:ISD<Ph_pt>:DUT:TYPE.....                | 620 |
| CALCulate:FModel:ISD<Ph_pt>:DUT[:STATe].....             | 620 |
| CALCulate:FModel:ISD<Ph_pt>:FTIME:DUT.....               | 620 |
| CALCulate:FModel:ISD<Ph_pt>:FTIME:OVERride.....          | 621 |
| CALCulate:FModel:ISD<Ph_pt>:OPERation.....               | 621 |
| CALCulate:FModel:ISD<Ph_pt>:PASSivity.....               | 621 |
| CALCulate:FModel:ISD<Ph_pt>:PORT:ORder.....              | 622 |
| CALCulate:FModel:ISD<Ph_pt>:PORT:SKIP.....               | 622 |
| CALCulate:FModel:ISD<Ph_pt>:PORT:SKIP:LEFT.....          | 622 |
| CALCulate:FModel:ISD<Ph_pt>:PORT:SKIP:NONE.....          | 622 |
| CALCulate:FModel:ISD<Ph_pt>:PORT:SKIP:RIGHT.....         | 622 |
| CALCulate:FModel:ISD<Ph_pt>:RUN:RUN.....                 | 623 |
| CALCulate:FModel:ISD<Ph_pt>:RUN[:STATe].....             | 623 |
| CALCulate:FModel:ISD<Ph_pt>:SCALE:ATTenuation.....       | 623 |
| CALCulate:FModel:ISD<Ph_pt>:SCALE:FREquency.....         | 624 |
| CALCulate:FModel:ISD<Ph_pt>:SCALE:FTIME.....             | 624 |
| CALCulate:FModel:ISD<Ph_pt>:SMALIfixture.....            | 619 |
| CALCulate:FModel:ISD<Ph_pt>:SMALIfixture.....            | 620 |
| CALCulate:FModel:ISD<Ph_pt>:TRACe:COUPling.....          | 624 |
| CALCulate:FModel:REName.....                             | 642 |
| CALCulate:FModel:SFD<Ph_pt>:AUTO.....                    | 625 |
| CALCulate:FModel:SFD<Ph_pt>:COUPon:MEASure.....          | 625 |
| CALCulate:FModel:SFD<Ph_pt>:COUPon:MEASure:FILEname..... | 626 |
| CALCulate:FModel:SFD<Ph_pt>:COUPon:TYPE.....             | 626 |
| CALCulate:FModel:SFD<Ph_pt>:COUPon[:STATe].....          | 626 |
| CALCulate:FModel:SFD<Ph_pt>:DIFFcfg.....                 | 626 |
| CALCulate:FModel:SFD<Ph_pt>:DUT:MEASure.....             | 627 |
| CALCulate:FModel:SFD<Ph_pt>:DUT:MEASure:FILEname.....    | 627 |
| CALCulate:FModel:SFD<Ph_pt>:DUT[:STATe].....             | 627 |
| CALCulate:FModel:SFD<Ph_pt>:RUN:RUN.....                 | 627 |
| CALCulate:FModel:SFD<Ph_pt>:RUN[:STATe].....             | 628 |
| CALCulate:FModel:SFD<Ph_pt>:TOTaldiffcfig.....           | 628 |
| CALCulate:LIMit:CIRClE:FAIL:ALL?.....                    | 647 |
| CALCulate:LIMit:FAIL:ALL?.....                           | 647 |
| CALCulate:LIMit:FAIL:DATA?.....                          | 647 |
| CALCulate:MARKer:COUPlEd:TYPE.....                       | 664 |
| CALCulate:MARKer:COUPlEd[:STATe].....                    | 663 |
| CALCulate:MARKer:FUNCTion:BWIDth:GMCenter.....           | 664 |
| CALCulate:PARAmeter:DELete:ALL.....                      | 692 |
| CALCulate:PARAmeter:DELete:MEMory.....                   | 692 |
| CALCulate:PIPelining:DATA?.....                          | 709 |
| CALCulate:RIPPlE:DISPlay:RESult:ALL[:STATe].....         | 701 |
| CALCulate:RIPPlE:FAIL:ALL?.....                          | 702 |
| CALCulate:TDVSwr[:STATe].....                            | 721 |
| CALCulate<Ch>:DATA:CALL.....                             | 601 |
| CALCulate<Ch>:DATA:CALL:CATalog?.....                    | 603 |

|                                                                                     |      |
|-------------------------------------------------------------------------------------|------|
| CALCulate<Ch>:DATA:CHANnel:ALL?                                                     | 603  |
| CALCulate<Ch>:DATA:CHANnel:DALL?                                                    | 603  |
| CALCulate<Ch>:DATA:MDATa:INTerpolate                                                | 604  |
| CALCulate<Ch>:DATA:SGRoup?                                                          | 604  |
| CALCulate<Ch>:PARAmeter:CATalog:SEnDed?                                             | 693  |
| CALCulate<Ch>:PARAmeter:CATalog?                                                    | 692  |
| CALCulate<Ch>:PARAmeter:DEFine                                                      | 1090 |
| CALCulate<Ch>:PARAmeter:DEFine:SGRoup                                               | 693  |
| CALCulate<Ch>:PARAmeter:DELeTe                                                      | 694  |
| CALCulate<Ch>:PARAmeter:DELeTe:CALL                                                 | 695  |
| CALCulate<Ch>:PARAmeter:DELeTe:CMEMory                                              | 695  |
| CALCulate<Ch>:PARAmeter:DELeTe:SGRoup                                               | 695  |
| CALCulate<Ch>:PARAmeter:MEASure                                                     | 696  |
| CALCulate<Ch>:PARAmeter:MEASure:SEnDed                                              | 697  |
| CALCulate<Ch>:PARAmeter:SDEFine                                                     | 697  |
| CALCulate<Ch>:PARAmeter:SDEFine:SEnDed                                              | 699  |
| CALCulate<Ch>:PARAmeter:SELeCt                                                      | 700  |
| CALCulate<Ch>:TRANSform:VNETworks:BALanced:DEEMbedding<LogPt>:PARAmeters:C<Cmp>     | 744  |
| CALCulate<Ch>:TRANSform:VNETworks:BALanced:DEEMbedding<LogPt>:PARAmeters:DATA<Port> | 745  |
| CALCulate<Ch>:TRANSform:VNETworks:BALanced:DEEMbedding<LogPt>:PARAmeters:G<Cmp>     | 746  |
| CALCulate<Ch>:TRANSform:VNETworks:BALanced:DEEMbedding<LogPt>:PARAmeters:L<Cmp>     | 746  |
| CALCulate<Ch>:TRANSform:VNETworks:BALanced:DEEMbedding<LogPt>:PARAmeters:R<Cmp>     | 747  |
| CALCulate<Ch>:TRANSform:VNETworks:BALanced:DEEMbedding<LogPt>:TNDefinition          | 748  |
| CALCulate<Ch>:TRANSform:VNETworks:BALanced:DEEMbedding<LogPt>[:STATE]               | 743  |
| CALCulate<Ch>:TRANSform:VNETworks:BALanced:EMBedding<LogPt>:PARAmeters:C<Cmp>       | 749  |
| CALCulate<Ch>:TRANSform:VNETworks:BALanced:EMBedding<LogPt>:PARAmeters:DATA<Port>   | 750  |
| CALCulate<Ch>:TRANSform:VNETworks:BALanced:EMBedding<LogPt>:PARAmeters:G<Cmp>       | 751  |
| CALCulate<Ch>:TRANSform:VNETworks:BALanced:EMBedding<LogPt>:PARAmeters:L<Cmp>       | 751  |
| CALCulate<Ch>:TRANSform:VNETworks:BALanced:EMBedding<LogPt>:PARAmeters:R<Cmp>       | 752  |
| CALCulate<Ch>:TRANSform:VNETworks:BALanced:EMBedding<LogPt>:TNDefinition            | 753  |
| CALCulate<Ch>:TRANSform:VNETworks:BALanced:EMBedding<LogPt>[:STATE]                 | 748  |
| CALCulate<Ch>:TRANSform:VNETworks:DIFFerential:EMBedding<LogPt>:PARAmeters:C<Cmp>   | 754  |
| CALCulate<Ch>:TRANSform:VNETworks:DIFFerential:EMBedding<LogPt>:PARAmeters:DATA     | 754  |
| CALCulate<Ch>:TRANSform:VNETworks:DIFFerential:EMBedding<LogPt>:PARAmeters:G<Cmp>   | 755  |
| CALCulate<Ch>:TRANSform:VNETworks:DIFFerential:EMBedding<LogPt>:PARAmeters:L<Cmp>   | 755  |
| CALCulate<Ch>:TRANSform:VNETworks:DIFFerential:EMBedding<LogPt>:PARAmeters:R<Cmp>   | 756  |
| CALCulate<Ch>:TRANSform:VNETworks:DIFFerential:EMBedding<LogPt>:TNDefinition        | 756  |
| CALCulate<Ch>:TRANSform:VNETworks:DIFFerential:EMBedding<LogPt>[:STATE]             | 753  |
| CALCulate<Ch>:TRANSform:VNETworks:FSIMulator[:STATE]                                | 763  |
| CALCulate<Ch>:TRANSform:VNETworks:GLOop:DEEMbedding:PARAmeters:C                    | 757  |
| CALCulate<Ch>:TRANSform:VNETworks:GLOop:DEEMbedding:PARAmeters:G                    | 757  |
| CALCulate<Ch>:TRANSform:VNETworks:GLOop:DEEMbedding:PARAmeters:L                    | 758  |
| CALCulate<Ch>:TRANSform:VNETworks:GLOop:DEEMbedding:PARAmeters:R                    | 759  |
| CALCulate<Ch>:TRANSform:VNETworks:GLOop:DEEMbedding:TNDefinition                    | 759  |
| CALCulate<Ch>:TRANSform:VNETworks:GLOop:DEEMbedding[:STATE]                         | 756  |
| CALCulate<Ch>:TRANSform:VNETworks:GLOop:EMBedding:PARAmeters:C                      | 760  |
| CALCulate<Ch>:TRANSform:VNETworks:GLOop:EMBedding:PARAmeters:G                      | 761  |
| CALCulate<Ch>:TRANSform:VNETworks:GLOop:EMBedding:PARAmeters:L                      | 761  |
| CALCulate<Ch>:TRANSform:VNETworks:GLOop:EMBedding:PARAmeters:R                      | 762  |
| CALCulate<Ch>:TRANSform:VNETworks:GLOop:EMBedding:TNDefinition                      | 762  |

|                                                                                      |     |
|--------------------------------------------------------------------------------------|-----|
| CALCulate<Ch>:TRANSform:VNETworks:GLOop:EMBedding[:STATe].....                       | 760 |
| CALCulate<Ch>:TRANSform:VNETworks:GLOop:GROup.....                                   | 763 |
| CALCulate<Ch>:TRANSform:VNETworks:PPAir:DEEMbedding:DELeTe.....                      | 763 |
| CALCulate<Ch>:TRANSform:VNETworks:PPAir:DEEMbedding<ListId>:DEFine.....              | 764 |
| CALCulate<Ch>:TRANSform:VNETworks:PPAir:DEEMbedding<ListId>:PARAmeters:C<1 2 3>..... | 765 |
| CALCulate<Ch>:TRANSform:VNETworks:PPAir:DEEMbedding<ListId>:PARAmeters:G<1 2 3>..... | 765 |
| CALCulate<Ch>:TRANSform:VNETworks:PPAir:DEEMbedding<ListId>:PARAmeters:L<1 2 3>..... | 766 |
| CALCulate<Ch>:TRANSform:VNETworks:PPAir:DEEMbedding<ListId>:PARAmeters:R<1 2 3>..... | 767 |
| CALCulate<Ch>:TRANSform:VNETworks:PPAir:DEEMbedding<ListId>:TNDefinition.....        | 767 |
| CALCulate<Ch>:TRANSform:VNETworks:PPAir:DEEMbedding<ListId>[:STATe].....             | 763 |
| CALCulate<Ch>:TRANSform:VNETworks:PPAir:EMBedding<ListId>:DEFine.....                | 768 |
| CALCulate<Ch>:TRANSform:VNETworks:PPAir:EMBedding<ListId>:DELeTe.....                | 769 |
| CALCulate<Ch>:TRANSform:VNETworks:PPAir:EMBedding<ListId>:PARAmeters:C<1 2 3>.....   | 769 |
| CALCulate<Ch>:TRANSform:VNETworks:PPAir:EMBedding<ListId>:PARAmeters:G<1 2 3>.....   | 771 |
| CALCulate<Ch>:TRANSform:VNETworks:PPAir:EMBedding<ListId>:PARAmeters:L<1 2 3>.....   | 770 |
| CALCulate<Ch>:TRANSform:VNETworks:PPAir:EMBedding<ListId>:PARAmeters:R<1 2 3>.....   | 771 |
| CALCulate<Ch>:TRANSform:VNETworks:PPAir:EMBedding<ListId>:TNDefinition.....          | 772 |
| CALCulate<Ch>:TRANSform:VNETworks:PPAir:EMBedding<ListId>[:STATe].....               | 768 |
| CALCulate<Ch>:TRANSform:VNETworks:PSET:DEEMbedding<ListId>:DEFine.....               | 773 |
| CALCulate<Ch>:TRANSform:VNETworks:PSET:EMBedding<ListId>:DEFine.....                 | 773 |
| CALCulate<Ch>:TRANSform:VNETworks:SENDEd:DEEMbedding<PhyPt>:PARAmeters:C<Cmp>.....   | 774 |
| CALCulate<Ch>:TRANSform:VNETworks:SENDEd:DEEMbedding<PhyPt>:PARAmeters:DATA.....     | 774 |
| CALCulate<Ch>:TRANSform:VNETworks:SENDEd:DEEMbedding<PhyPt>:PARAmeters:G<Cmp>.....   | 775 |
| CALCulate<Ch>:TRANSform:VNETworks:SENDEd:DEEMbedding<PhyPt>:PARAmeters:L<Cmp>.....   | 776 |
| CALCulate<Ch>:TRANSform:VNETworks:SENDEd:DEEMbedding<PhyPt>:PARAmeters:R<Cmp>.....   | 777 |
| CALCulate<Ch>:TRANSform:VNETworks:SENDEd:DEEMbedding<PhyPt>:TNDefinition.....        | 777 |
| CALCulate<Ch>:TRANSform:VNETworks:SENDEd:DEEMbedding<PhyPt>[:STATe].....             | 773 |
| CALCulate<Ch>:TRANSform:VNETworks:SENDEd:EMBedding<PhyPt>:PARAmeters:C<Cmp>.....     | 779 |
| CALCulate<Ch>:TRANSform:VNETworks:SENDEd:EMBedding<PhyPt>:PARAmeters:DATA.....       | 778 |
| CALCulate<Ch>:TRANSform:VNETworks:SENDEd:EMBedding<PhyPt>:PARAmeters:G<Cmp>.....     | 780 |
| CALCulate<Ch>:TRANSform:VNETworks:SENDEd:EMBedding<PhyPt>:PARAmeters:L<Cmp>.....     | 780 |
| CALCulate<Ch>:TRANSform:VNETworks:SENDEd:EMBedding<PhyPt>:PARAmeters:R<Cmp>.....     | 781 |
| CALCulate<Ch>:TRANSform:VNETworks:SENDEd:EMBedding<PhyPt>:TNDefinition.....          | 782 |
| CALCulate<Ch>:TRANSform:VNETworks:SENDEd:EMBedding<PhyPt>[:STATe].....               | 778 |
| CALCulate<Ch>:TRANSform:VNETworks:WAVes.....                                         | 782 |
| CALCulate<Chn>:DATA.....                                                             | 604 |
| CALCulate<Chn>:DATA:NSWeep:COUNT?.....                                               | 608 |
| CALCulate<Chn>:DATA:NSWeep:FIRST?.....                                               | 608 |
| CALCulate<Chn>:DATA:NSWeep[:LAST]?.....                                              | 607 |
| CALCulate<Chn>:DATA:STIMulus?.....                                                   | 609 |
| CALCulate<Chn>:DLINe.....                                                            | 609 |
| CALCulate<Chn>:DLINe:STATe.....                                                      | 610 |
| CALCulate<Chn>:FILTer[:GATE]:TIME:CENTer.....                                        | 611 |
| CALCulate<Chn>:FILTer[:GATE]:TIME:DCHebyshev.....                                    | 612 |
| CALCulate<Chn>:FILTer[:GATE]:TIME:SHAPE.....                                         | 612 |
| CALCulate<Chn>:FILTer[:GATE]:TIME:SHOW.....                                          | 613 |
| CALCulate<Chn>:FILTer[:GATE]:TIME:SPAN.....                                          | 613 |
| CALCulate<Chn>:FILTer[:GATE]:TIME:STARt.....                                         | 614 |
| CALCulate<Chn>:FILTer[:GATE]:TIME:STATe.....                                         | 614 |
| CALCulate<Chn>:FILTer[:GATE]:TIME:STOP.....                                          | 614 |

|                                                        |      |
|--------------------------------------------------------|------|
| CALCulate<Chn>:FILTer[:GATE]:TIME:WINDow.....          | 615  |
| CALCulate<Chn>:FILTer[:GATE]:TIME[:TYPE].....          | 611  |
| CALCulate<Chn>:FORMat.....                             | 643  |
| CALCulate<Chn>:FORMat:WQUType.....                     | 644  |
| CALCulate<Chn>:GDAPerture:SCOUnt.....                  | 645  |
| CALCulate<Chn>:IAverage:MODE.....                      | 645  |
| CALCulate<Chn>:IAverage[:STATe].....                   | 645  |
| CALCulate<Chn>:LIMit:CIRClE:CLEar.....                 | 648  |
| CALCulate<Chn>:LIMit:CIRClE:DATA.....                  | 648  |
| CALCulate<Chn>:LIMit:CIRClE:DISPlay[:STATe].....       | 648  |
| CALCulate<Chn>:LIMit:CIRClE:FAIL?.....                 | 649  |
| CALCulate<Chn>:LIMit:CIRClE:SOUNd[:STATe].....         | 649  |
| CALCulate<Chn>:LIMit:CIRClE[:STATe].....               | 647  |
| CALCulate<Chn>:LIMit:CLEar.....                        | 649  |
| CALCulate<Chn>:LIMit:CONTRol:DOMain.....               | 1088 |
| CALCulate<Chn>:LIMit:CONTRol:SHIFt.....                | 650  |
| CALCulate<Chn>:LIMit:CONTRol[:DATA].....               | 649  |
| CALCulate<Chn>:LIMit:DATA.....                         | 651  |
| CALCulate<Chn>:LIMit:DCIRclE:CLEar.....                | 652  |
| CALCulate<Chn>:LIMit:DCIRclE:DATA.....                 | 652  |
| CALCulate<Chn>:LIMit:DCIRclE:DISPlay[:STATe].....      | 653  |
| CALCulate<Chn>:LIMit:DCIRclE[:STATe].....              | 652  |
| CALCulate<Chn>:LIMit:DELeTe:ALL.....                   | 653  |
| CALCulate<Chn>:LIMit:DISPlay[:STATe].....              | 653  |
| CALCulate<Chn>:LIMit:FAIL?.....                        | 654  |
| CALCulate<Chn>:LIMit:LOWer:FEED.....                   | 656  |
| CALCulate<Chn>:LIMit:LOWer:SHIFt.....                  | 656  |
| CALCulate<Chn>:LIMit:LOWer:STATe.....                  | 1090 |
| CALCulate<Chn>:LIMit:LOWer[:DATA].....                 | 654  |
| CALCulate<Chn>:LIMit:RDOMain:COMPlEx.....              | 1088 |
| CALCulate<Chn>:LIMit:RDOMain:FORMat.....               | 1089 |
| CALCulate<Chn>:LIMit:RDOMain:SPACing.....              | 1089 |
| CALCulate<Chn>:LIMit:SEGMeNt:COUNt?.....               | 658  |
| CALCulate<Chn>:LIMit:SEGMeNt<Seg>:AMPLitude:STARt..... | 657  |
| CALCulate<Chn>:LIMit:SEGMeNt<Seg>:AMPLitude:STOP.....  | 657  |
| CALCulate<Chn>:LIMit:SEGMeNt<Seg>:FORMula.....         | 658  |
| CALCulate<Chn>:LIMit:SEGMeNt<Seg>:FORMula:STATe.....   | 658  |
| CALCulate<Chn>:LIMit:SEGMeNt<Seg>:INterPol.....        | 659  |
| CALCulate<Chn>:LIMit:SEGMeNt<Seg>:STIMulus:STARt.....  | 659  |
| CALCulate<Chn>:LIMit:SEGMeNt<Seg>:STIMulus:STOP.....   | 659  |
| CALCulate<Chn>:LIMit:SEGMeNt<Seg>:TYPE.....            | 660  |
| CALCulate<Chn>:LIMit:SOUNd[:STATe].....                | 661  |
| CALCulate<Chn>:LIMit:STATe.....                        | 661  |
| CALCulate<Chn>:LIMit:STATe:AREA.....                   | 661  |
| CALCulate<Chn>:LIMit:TTLout<Pt>[:STATe].....           | 662  |
| CALCulate<Chn>:LIMit:UPPer:FEED.....                   | 656  |
| CALCulate<Chn>:LIMit:UPPer:SHIFt.....                  | 656  |
| CALCulate<Chn>:LIMit:UPPer:STATe.....                  | 1090 |
| CALCulate<Chn>:LIMit:UPPer[:DATA].....                 | 654  |
| CALCulate<Chn>:MARKer:DEFault:FORMat.....              | 665  |

|                                                               |      |
|---------------------------------------------------------------|------|
| CALCulate<Chn>:MARKer:MPEak:EXCursion.....                    | 666  |
| CALCulate<Chn>:MARKer:MPEak:EXCursion:STATE.....              | 667  |
| CALCulate<Chn>:MARKer:MPEak:THReshold.....                    | 667  |
| CALCulate<Chn>:MARKer:MPEak:THReshold:STATE.....              | 667  |
| CALCulate<Chn>:MARKer:SEARch:BFILter:RESult[:STATE].....      | 668  |
| CALCulate<Chn>:MARKer:SEARch:BFILter:RESult[:STATE]:AREA..... | 668  |
| CALCulate<Chn>:MARKer[:STATE]:AREA.....                       | 665  |
| CALCulate<Chn>:MARKer<Mk>:AOFF.....                           | 668  |
| CALCulate<Chn>:MARKer<Mk>:BWIDth.....                         | 669  |
| CALCulate<Chn>:MARKer<Mk>:DELTA[:STATE].....                  | 670  |
| CALCulate<Chn>:MARKer<Mk>:EXCursion.....                      | 670  |
| CALCulate<Chn>:MARKer<Mk>:EXCursion:STATE.....                | 671  |
| CALCulate<Chn>:MARKer<Mk>:FORMat.....                         | 671  |
| CALCulate<Chn>:MARKer<Mk>:FUNCTion:BWIDth.....                | 1092 |
| CALCulate<Chn>:MARKer<Mk>:FUNCTion:BWIDth:MODE.....           | 672  |
| CALCulate<Chn>:MARKer<Mk>:FUNCTion:CENTer.....                | 672  |
| CALCulate<Chn>:MARKer<Mk>:FUNCTion:DELTA:STATE.....           | 1092 |
| CALCulate<Chn>:MARKer<Mk>:FUNCTion:DOMain:USER:SHOW.....      | 673  |
| CALCulate<Chn>:MARKer<Mk>:FUNCTion:DOMain:USER:START.....     | 674  |
| CALCulate<Chn>:MARKer<Mk>:FUNCTion:DOMain:USER:STOP.....      | 674  |
| CALCulate<Chn>:MARKer<Mk>:FUNCTion:DOMain:USER[:RANGe].....   | 673  |
| CALCulate<Chn>:MARKer<Mk>:FUNCTion:EXECute.....               | 674  |
| CALCulate<Chn>:MARKer<Mk>:FUNCTion:RESult?.....               | 675  |
| CALCulate<Chn>:MARKer<Mk>:FUNCTion:SPAN.....                  | 675  |
| CALCulate<Chn>:MARKer<Mk>:FUNCTion:START.....                 | 676  |
| CALCulate<Chn>:MARKer<Mk>:FUNCTion:STOP.....                  | 676  |
| CALCulate<Chn>:MARKer<Mk>:FUNCTion:TARGet.....                | 1092 |
| CALCulate<Chn>:MARKer<Mk>:FUNCTion[:SELEct].....              | 1093 |
| CALCulate<Chn>:MARKer<Mk>:MAXimum.....                        | 1093 |
| CALCulate<Chn>:MARKer<Mk>:MINimum.....                        | 1093 |
| CALCulate<Chn>:MARKer<Mk>:MODE.....                           | 676  |
| CALCulate<Chn>:MARKer<Mk>:NAME.....                           | 677  |
| CALCulate<Chn>:MARKer<Mk>:REFerence:FORMat.....               | 678  |
| CALCulate<Chn>:MARKer<Mk>:REFerence:MODE.....                 | 678  |
| CALCulate<Chn>:MARKer<Mk>:REFerence:NAME.....                 | 679  |
| CALCulate<Chn>:MARKer<Mk>:REFerence:TYPE.....                 | 679  |
| CALCulate<Chn>:MARKer<Mk>:REFerence:X.....                    | 680  |
| CALCulate<Chn>:MARKer<Mk>:REFerence:Y.....                    | 680  |
| CALCulate<Chn>:MARKer<Mk>:REFerence[:STATE].....              | 677  |
| CALCulate<Chn>:MARKer<Mk>:SEARch:FORMat.....                  | 682  |
| CALCulate<Chn>:MARKer<Mk>:SEARch:LEFT.....                    | 1094 |
| CALCulate<Chn>:MARKer<Mk>:SEARch:NEXT.....                    | 1094 |
| CALCulate<Chn>:MARKer<Mk>:SEARch:RIGHT.....                   | 1094 |
| CALCulate<Chn>:MARKer<Mk>:SEARch:TRACKing.....                | 681  |
| CALCulate<Chn>:MARKer<Mk>:SEARch[:IMMediate].....             | 1094 |
| CALCulate<Chn>:MARKer<Mk>:TARGet.....                         | 683  |
| CALCulate<Chn>:MARKer<Mk>:THReshold.....                      | 684  |
| CALCulate<Chn>:MARKer<Mk>:THReshold:STATE.....                | 684  |
| CALCulate<Chn>:MARKer<Mk>:TYPE.....                           | 685  |
| CALCulate<Chn>:MARKer<Mk>:X.....                              | 686  |

|                                                                |      |
|----------------------------------------------------------------|------|
| CALCulate<Chn>:MARKer<Mk>:Y.....                               | 686  |
| CALCulate<Chn>:MARKer<Mk>[:STATe].....                         | 683  |
| CALCulate<Chn>:MATH:FORMatted:FUNCtion.....                    | 689  |
| CALCulate<Chn>:MATH:FORMatted:STATe.....                       | 690  |
| CALCulate<Chn>:MATH:FORMatted[:EXPRession]:SDEFine.....        | 688  |
| CALCulate<Chn>:MATH:FUNCtion.....                              | 689  |
| CALCulate<Chn>:MATH:MEMorize.....                              | 690  |
| CALCulate<Chn>:MATH:STATe.....                                 | 690  |
| CALCulate<Chn>:MATH:WUNit[:STATe].....                         | 691  |
| CALCulate<Chn>:MATH[:EXPRession]:SDEFine.....                  | 688  |
| CALCulate<Chn>:MATH[:EXPRession][:DEFine].....                 | 1094 |
| CALCulate<Chn>:PHOLd.....                                      | 700  |
| CALCulate<Chn>:RIPPlE:CLEar.....                               | 702  |
| CALCulate<Chn>:RIPPlE:CONTRol:DOMain.....                      | 702  |
| CALCulate<Chn>:RIPPlE:DATA.....                                | 703  |
| CALCulate<Chn>:RIPPlE:DELeTe:ALL.....                          | 704  |
| CALCulate<Chn>:RIPPlE:DISPlay[:STATe].....                     | 704  |
| CALCulate<Chn>:RIPPlE:FAIL?.....                               | 704  |
| CALCulate<Chn>:RIPPlE:RDOMain:FORMat.....                      | 705  |
| CALCulate<Chn>:RIPPlE:SEGMENT:COUNT?.....                      | 705  |
| CALCulate<Chn>:RIPPlE:SEGMENT<Seg>:LIMit.....                  | 706  |
| CALCulate<Chn>:RIPPlE:SEGMENT<Seg>:RESult?.....                | 707  |
| CALCulate<Chn>:RIPPlE:SEGMENT<Seg>:STIMulus:START.....         | 708  |
| CALCulate<Chn>:RIPPlE:SEGMENT<Seg>:STIMulus:STOP.....          | 708  |
| CALCulate<Chn>:RIPPlE:SEGMENT<Seg>[:STATe].....                | 706  |
| CALCulate<Chn>:RIPPlE:SOUNd[:STATe].....                       | 708  |
| CALCulate<Chn>:RIPPlE:STATe.....                               | 709  |
| CALCulate<Chn>:RIPPlE:STATe:AREA.....                          | 709  |
| CALCulate<Chn>:SMOothing:APERture.....                         | 711  |
| CALCulate<Chn>:SMOothing[:STATe].....                          | 710  |
| CALCulate<Chn>:STATistics:DOMain:USER.....                     | 713  |
| CALCulate<Chn>:STATistics:DOMain:USER:SHOW.....                | 713  |
| CALCulate<Chn>:STATistics:DOMain:USER:START.....               | 713  |
| CALCulate<Chn>:STATistics:DOMain:USER:STOP.....                | 713  |
| CALCulate<Chn>:STATistics:EPDelay[:STATe].....                 | 714  |
| CALCulate<Chn>:STATistics:FORMat.....                          | 714  |
| CALCulate<Chn>:STATistics:MMPTpeak[:STATe].....                | 714  |
| CALCulate<Chn>:STATistics:MSTDdev[:STATe].....                 | 714  |
| CALCulate<Chn>:STATistics:NLINear:COMP:LEVel.....              | 715  |
| CALCulate<Chn>:STATistics:NLINear:COMP:PHASe.....              | 715  |
| CALCulate<Chn>:STATistics:NLINear:COMP:RDOMain:USER.....       | 715  |
| CALCulate<Chn>:STATistics:NLINear:COMP:RDOMain:USER:SHOW.....  | 716  |
| CALCulate<Chn>:STATistics:NLINear:COMP:RDOMain:USER:START..... | 716  |
| CALCulate<Chn>:STATistics:NLINear:COMP:RDOMain:USER:STOP.....  | 716  |
| CALCulate<Chn>:STATistics:NLINear:COMP:REFerence.....          | 716  |
| CALCulate<Chn>:STATistics:NLINear:COMP:RESult?.....            | 717  |
| CALCulate<Chn>:STATistics:NLINear:COMP:RLEVel.....             | 718  |
| CALCulate<Chn>:STATistics:NLINear:COMP:RMARker.....            | 718  |
| CALCulate<Chn>:STATistics:NLINear:COMP:RPHase.....             | 718  |
| CALCulate<Chn>:STATistics:NLINear:COMP:RPHase.....             | 719  |



|                                                               |     |
|---------------------------------------------------------------|-----|
| CALCulate<Chn>:STATistics:NLINear:COMP[:STATe].....           | 719 |
| CALCulate<Chn>:STATistics:RESult?.....                        | 719 |
| CALCulate<Chn>:STATistics:RMS[:STATe].....                    | 720 |
| CALCulate<Chn>:STATistics:SFLatness[:STATe].....              | 720 |
| CALCulate<Chn>:STATistics[:STATe].....                        | 712 |
| CALCulate<Chn>:STATistics[:STATe]:AREA.....                   | 712 |
| CALCulate<Chn>:TRANSform:COMPLex.....                         | 721 |
| CALCulate<Chn>:TRANSform:DTFault:CENTer.....                  | 731 |
| CALCulate<Chn>:TRANSform:DTFault:DEFine.....                  | 730 |
| CALCulate<Chn>:TRANSform:DTFault:DELete.....                  | 731 |
| CALCulate<Chn>:TRANSform:DTFault:PEAK:COUNT?.....             | 732 |
| CALCulate<Chn>:TRANSform:DTFault:PEAK:DATA<FaultNo>.....      | 732 |
| CALCulate<Chn>:TRANSform:DTFault:PEAK:STATe.....              | 733 |
| CALCulate<Chn>:TRANSform:DTFault:PEAK:THReshold.....          | 733 |
| CALCulate<Chn>:TRANSform:DTFault:POINts.....                  | 734 |
| CALCulate<Chn>:TRANSform:DTFault:SElect.....                  | 731 |
| CALCulate<Chn>:TRANSform:DTFault:SPAN.....                    | 731 |
| CALCulate<Chn>:TRANSform:DTFault:STARt.....                   | 734 |
| CALCulate<Chn>:TRANSform:DTFault:STATe.....                   | 735 |
| CALCulate<Chn>:TRANSform:DTFault:STOP.....                    | 734 |
| CALCulate<Chn>:TRANSform:IMPedance:RNORmal.....               | 722 |
| CALCulate<Chn>:TRANSform:TIME:CENTer.....                     | 723 |
| CALCulate<Chn>:TRANSform:TIME:DCHebyshev.....                 | 724 |
| CALCulate<Chn>:TRANSform:TIME:LPASs.....                      | 724 |
| CALCulate<Chn>:TRANSform:TIME:LPASs:DCSParam.....             | 724 |
| CALCulate<Chn>:TRANSform:TIME:LPASs:DCSParam:CONTInuous.....  | 725 |
| CALCulate<Chn>:TRANSform:TIME:LPASs:DCSParam:EXTRapolate..... | 726 |
| CALCulate<Chn>:TRANSform:TIME:LPFRequency.....                | 726 |
| CALCulate<Chn>:TRANSform:TIME:RESolution:EFACtor.....         | 726 |
| CALCulate<Chn>:TRANSform:TIME:SPAN.....                       | 726 |
| CALCulate<Chn>:TRANSform:TIME:STARt.....                      | 727 |
| CALCulate<Chn>:TRANSform:TIME:STATe.....                      | 727 |
| CALCulate<Chn>:TRANSform:TIME:STIMulus.....                   | 728 |
| CALCulate<Chn>:TRANSform:TIME:STOP.....                       | 728 |
| CALCulate<Chn>:TRANSform:TIME:WINDow.....                     | 729 |
| CALCulate<Chn>:TRANSform:TIME:XAXis.....                      | 729 |
| CALCulate<Chn>:TRANSform:TIME[:TYPE].....                     | 722 |
| CONFigure:CHANnel:CATalog?.....                               | 783 |
| CONFigure:CHANnel:MEASure:ALL[:STATe].....                    | 784 |
| CONFigure:CHANnel:MEASure:OPTImized.....                      | 784 |
| CONFigure:CHANnel<Ch>:MEASure[:STATe].....                    | 786 |
| CONFigure:CHANnel<Ch>:NAME.....                               | 786 |
| CONFigure:CHANnel<Ch>:NAME:ID?.....                           | 786 |
| CONFigure:CHANnel<Ch>:TRACe:CATalog?.....                     | 787 |
| CONFigure:CHANnel<Ch>:TRACe:REName.....                       | 787 |
| CONFigure:CHANnel<Ch>[:STATe].....                            | 785 |
| CONFigure:TRACe:CATalog?.....                                 | 788 |
| CONFigure:TRACe:WINDow:TRACe?.....                            | 789 |
| CONFigure:TRACe:WINDow?.....                                  | 788 |
| CONFigure:TRACe<Trc>:CHANnel:NAME:ID?.....                    | 789 |



|                                            |      |
|--------------------------------------------|------|
| CONFigure:TRACe<Trc>:CHANnel:NAME?         | 789  |
| CONFigure:TRACe<Trc>:NAME                  | 790  |
| CONFigure:TRACe<Trc>:NAME:ID?              | 790  |
| CONFigure:TRACe<Trc>:REName                | 790  |
| CONTrOl:AUXiliary:C[:DATA]                 | 792  |
| CONTrOl:HANDler:A:MODE                     | 794  |
| CONTrOl:HANDler:A[:DATA]                   | 793  |
| CONTrOl:HANDler:B:MODE                     | 794  |
| CONTrOl:HANDler:B[:DATA]                   | 793  |
| CONTrOl:HANDler:C:MODE                     | 794  |
| CONTrOl:HANDler:C[:DATA]                   | 793  |
| CONTrOl:HANDler:D:MODE                     | 794  |
| CONTrOl:HANDler:D[:DATA]                   | 793  |
| CONTrOl:HANDler:E[:DATA]                   | 793  |
| CONTrOl:HANDler:F[:DATA]                   | 793  |
| CONTrOl:HANDler:G[:DATA]                   | 793  |
| CONTrOl:HANDler:H[:DATA]                   | 793  |
| CONTrOl:HANDler:INPut?                     | 795  |
| CONTrOl:HANDler:LOGic                      | 795  |
| CONTrOl:HANDler:OUTPut<Pt>:USER            | 796  |
| CONTrOl:HANDler:OUTPut<Pt>[:DATA]          | 796  |
| CONTrOl:HANDler:PASSfail:LOGic             | 797  |
| CONTrOl:HANDler:PASSfail:MODE              | 797  |
| CONTrOl:HANDler:PASSfail:POLicy            | 798  |
| CONTrOl:HANDler:PASSfail:SCOpe             | 798  |
| CONTrOl:HANDler:PASSfail:STATus?           | 799  |
| CONTrOl:HANDler:RESet                      | 799  |
| CONTrOl:HANDler:SWEepend                   | 799  |
| CONTrOl:HANDler[:EXTension]:INdex:STATe    | 794  |
| CONTrOl:HANDler[:EXTension]:RTRigger:STATe | 795  |
| DIAGnostic:DEVice:STATe                    | 800  |
| DIAGnostic:DUMP:SIZE                       | 801  |
| DIAGnostic:HUMS:BIOS?                      | 1072 |
| DIAGnostic:HUMS:DELeTe:ALL                 | 1073 |
| DIAGnostic:HUMS:DEVice:HISTory:DELeTe:ALL  | 1074 |
| DIAGnostic:HUMS:DEVice:HISTory?            | 1073 |
| DIAGnostic:HUMS:EQUipment?                 | 1074 |
| DIAGnostic:HUMS:FORMat                     | 1075 |
| DIAGnostic:HUMS:SAVE                       | 1075 |
| DIAGnostic:HUMS:SECurity?                  | 1075 |
| DIAGnostic:HUMS:SERVice?                   | 1076 |
| DIAGnostic:HUMS:STATe                      | 1077 |
| DIAGnostic:HUMS:STORage?                   | 1077 |
| DIAGnostic:HUMS:SW?                        | 1078 |
| DIAGnostic:HUMS:SYSTem:INFO?               | 1079 |
| DIAGnostic:HUMS:SYSTem:STATus:SUMMary?     | 1080 |
| DIAGnostic:HUMS:SYSTem:STATus?             | 1079 |
| DIAGnostic:HUMS:TAgS:ALL?                  | 1081 |
| DIAGnostic:HUMS:TAgS:DELeTe                | 1082 |
| DIAGnostic:HUMS:TAgS:DELeTe:ALL            | 1082 |

|                                                          |      |
|----------------------------------------------------------|------|
| DIAGnostic:HUMS:TAGS[:VALue].....                        | 1081 |
| DIAGnostic:HUMS:UTILization:ACTivity:TRACking:STATe..... | 1083 |
| DIAGnostic:HUMS:UTILization:HISTory:DELeTe:ALL.....      | 1084 |
| DIAGnostic:HUMS:UTILization:HISTory?.....                | 1084 |
| DIAGnostic:HUMS:UTILization?.....                        | 1082 |
| DIAGnostic:HUMS[:ALL]?.....                              | 1072 |
| DIAGnostic:PRODuct:OPTion:INFO?.....                     | 801  |
| DIAGnostic:SERVice:CALibration:DATE.....                 | 1085 |
| DIAGnostic:SERVice:CALibration:DUE:DATE.....             | 1085 |
| DIAGnostic:SERVice:CALibration:DUE:STATe?.....           | 1086 |
| DIAGnostic:SERVice:CALibration:INTerval?.....            | 1086 |
| DIAGnostic:SERVice:DATE.....                             | 1086 |
| DIAGnostic:SERVice:FUNCTion.....                         | 1095 |
| DIAGnostic:SERVice:RFPower.....                          | 801  |
| DIAGnostic:SERVice:SFUNCTion.....                        | 801  |
| DIAGnostic:SERVice:STATe?.....                           | 1086 |
| DISPlay:ANNotation:CHANnel[:STATe].....                  | 819  |
| DISPlay:ANNotation:FREQUency[:STATe].....                | 819  |
| DISPlay:ANNotation:TRACe[:STATe].....                    | 819  |
| DISPlay:CMAP:LIMit:FCOLORize[:STATe].....                | 819  |
| DISPlay:CMAP:LIMit:FSYMBOL[:STATe].....                  | 820  |
| DISPlay:CMAP:LIMit[:STATe].....                          | 820  |
| DISPlay:CMAP:MARKer[:STATe].....                         | 820  |
| DISPlay:CMAP:TRACe:COLor[:STATe].....                    | 822  |
| DISPlay:CMAP:TRACe:RGB.....                              | 823  |
| DISPlay:CMAP<DispEl>:RGB.....                            | 821  |
| DISPlay:IWINDow:BFILTer[:STATe].....                     | 804  |
| DISPlay:IWINDow:MARKer<Mk>[:STATe].....                  | 804  |
| DISPlay:IWINDow[:STATe].....                             | 804  |
| DISPlay:LAYout.....                                      | 824  |
| DISPlay:LAYout:APPLY.....                                | 824  |
| DISPlay:LAYout:DEFine.....                               | 824  |
| DISPlay:LAYout:EXECute.....                              | 825  |
| DISPlay:LAYout:GRID.....                                 | 826  |
| DISPlay:LAYout:JOIN.....                                 | 826  |
| DISPlay:MENU:KEY:ACTion:CATalog?.....                    | 827  |
| DISPlay:MENU:KEY:EXECute.....                            | 827  |
| DISPlay:MENU:KEY:SELeCt.....                             | 827  |
| DISPlay:MENU:KEY:TOOL:CATalog?.....                      | 828  |
| DISPlay:RFSize.....                                      | 828  |
| DISPlay[:WINDow<Wnd>]:CATalog?.....                      | 805  |
| DISPlay[:WINDow<Wnd>]:MAXimize.....                      | 805  |
| DISPlay[:WINDow<Wnd>]:NAME.....                          | 806  |
| DISPlay[:WINDow<Wnd>]:OVERview[:STATe].....              | 806  |
| DISPlay[:WINDow<Wnd>]:TITLe:DATA.....                    | 807  |
| DISPlay[:WINDow<Wnd>]:TITLe[:STATe].....                 | 807  |
| DISPlay[:WINDow<Wnd>]:TRACe<WndTr>:CATalog?.....         | 807  |
| DISPlay[:WINDow<Wnd>]:TRACe<WndTr>:DELeTe.....           | 808  |
| DISPlay[:WINDow<Wnd>]:TRACe<WndTr>:EFEed.....            | 808  |
| DISPlay[:WINDow<Wnd>]:TRACe<WndTr>:FEED.....             | 809  |

|                                                             |      |
|-------------------------------------------------------------|------|
| DISPlay[:WINDow<Wnd>]:TRACe<WndTr>:LABel:SHOW.....          | 809  |
| DISPlay[:WINDow<Wnd>]:TRACe<WndTr>:SHOW.....                | 810  |
| DISPlay[:WINDow<Wnd>]:TRACe<WndTr>:X:OFFSet.....            | 811  |
| DISPlay[:WINDow<Wnd>]:TRACe<WndTr>:Y:OFFSet.....            | 816  |
| DISPlay[:WINDow<Wnd>]:TRACe<WndTr>:Y[:SCALE]:AUTO.....      | 811  |
| DISPlay[:WINDow<Wnd>]:TRACe<WndTr>:Y[:SCALE]:BOTTom.....    | 812  |
| DISPlay[:WINDow<Wnd>]:TRACe<WndTr>:Y[:SCALE]:PDIVision..... | 813  |
| DISPlay[:WINDow<Wnd>]:TRACe<WndTr>:Y[:SCALE]:RLEVel.....    | 814  |
| DISPlay[:WINDow<Wnd>]:TRACe<WndTr>:Y[:SCALE]:RPOsition..... | 815  |
| DISPlay[:WINDow<Wnd>]:TRACe<WndTr>:Y[:SCALE]:TOP.....       | 812  |
| DISPlay[:WINDow<Wnd>]:TRACe<WndTr>:ZOOM:BOTTom.....         | 818  |
| DISPlay[:WINDow<Wnd>]:TRACe<WndTr>:ZOOM:START.....          | 818  |
| DISPlay[:WINDow<Wnd>]:TRACe<WndTr>:ZOOM:STOP.....           | 818  |
| DISPlay[:WINDow<Wnd>]:TRACe<WndTr>:ZOOM:TOP.....            | 818  |
| DISPlay[:WINDow<Wnd>]:TRACe<WndTr>:ZOOM[:STATe].....        | 817  |
| DISPlay[:WINDow<Wnd>][:STATe].....                          | 804  |
| FORMat:BORDer.....                                          | 829  |
| FORMat:DEXPort:SOURce.....                                  | 1095 |
| FORMat[:DATA].....                                          | 828  |
| HCOPY:DESTination.....                                      | 830  |
| HCOPY:DEVice:LANGUage.....                                  | 831  |
| HCOPY:ITEM:ALL.....                                         | 831  |
| HCOPY:ITEM:LOGO[:STATe].....                                | 831  |
| HCOPY:ITEM:MLISt[:STATe].....                               | 832  |
| HCOPY:ITEM:TIME[:STATe].....                                | 832  |
| HCOPY:PAGE:COLor.....                                       | 832  |
| HCOPY:PAGE:MARGIn:BOTTom.....                               | 833  |
| HCOPY:PAGE:MARGIn:LEFT.....                                 | 833  |
| HCOPY:PAGE:MARGIn:RIGHT.....                                | 834  |
| HCOPY:PAGE:MARGIn:TOP.....                                  | 834  |
| HCOPY:PAGE:ORlentation.....                                 | 834  |
| HCOPY:PAGE:WINDow.....                                      | 834  |
| HCOPY[:IMMediate].....                                      | 830  |
| INITiate:CONTInuous:ALL.....                                | 835  |
| INITiate:PIPElining:STATe.....                              | 836  |
| INITiate[:IMMediate]:ALL.....                               | 835  |
| INITiate<Ch>:CONTInuous.....                                | 837  |
| INITiate<Ch>[:IMMediate]:SCOPE.....                         | 836  |
| INITiate<Ch>[:IMMediate][:DUMMy].....                       | 836  |
| INSTrument:NSElect.....                                     | 838  |
| INSTrument:PORT:COUNT?.....                                 | 838  |
| INSTrument:SMATrix.....                                     | 839  |
| INSTrument:TPORT:COUNT?.....                                | 839  |
| INSTrument[:SElect].....                                    | 1096 |
| MEMory:CATalog:COUNT?.....                                  | 840  |
| MEMory:CATalog?.....                                        | 839  |
| MEMory:DEFine.....                                          | 840  |
| MEMory:DELeTe:ALL.....                                      | 840  |
| MEMory:DELeTe[:NAME].....                                   | 840  |
| MEMory:SElect.....                                          | 841  |

|                                                               |     |
|---------------------------------------------------------------|-----|
| MMEMory:AKAL:FACTory:CONVersion.....                          | 843 |
| MMEMory:AKAL:USER:CONVersion.....                             | 843 |
| MMEMory:CATalog:ALL?.....                                     | 845 |
| MMEMory:CATalog?.....                                         | 844 |
| MMEMory:CDIRectory.....                                       | 845 |
| MMEMory:CKIT:INFO?.....                                       | 845 |
| MMEMory:COPI.....                                             | 846 |
| MMEMory:DATA.....                                             | 846 |
| MMEMory:DELeTe.....                                           | 847 |
| MMEMory:DELeTe:CORRection.....                                | 847 |
| MMEMory:FAVorite<FavId>.....                                  | 847 |
| MMEMory:LOAD:CABLe.....                                       | 848 |
| MMEMory:LOAD:CKIT.....                                        | 848 |
| MMEMory:LOAD:CKIT:SDATa.....                                  | 849 |
| MMEMory:LOAD:CKIT:SDATa:WLABel.....                           | 850 |
| MMEMory:LOAD:CKIT:UDIRectory.....                             | 851 |
| MMEMory:LOAD:CMAPI.....                                       | 852 |
| MMEMory:LOAD:CORRection.....                                  | 852 |
| MMEMory:LOAD:CORRection:MERGe.....                            | 853 |
| MMEMory:LOAD:CORRection:RESolve.....                          | 854 |
| MMEMory:LOAD:CORRection:TCOefficient<Ch>.....                 | 855 |
| MMEMory:LOAD:LIMit.....                                       | 855 |
| MMEMory:LOAD:RIPPIle.....                                     | 857 |
| MMEMory:LOAD:SEGMeNt.....                                     | 858 |
| MMEMory:LOAD:STATe.....                                       | 859 |
| MMEMory:LOAD:TRACe.....                                       | 859 |
| MMEMory:LOAD:TRACe:AUTO.....                                  | 860 |
| MMEMory:LOAD:VNETworks<Ch>:BALanced:DEEMbedding<LogPt>.....   | 860 |
| MMEMory:LOAD:VNETworks<Ch>:BALanced:EMBedding<LogPt>.....     | 860 |
| MMEMory:LOAD:VNETworks<Ch>:DIFFerential:EMBedding<LogPt>..... | 862 |
| MMEMory:LOAD:VNETworks<Ch>:GLOop:DEEMbedding.....             | 862 |
| MMEMory:LOAD:VNETworks<Ch>:GLOop:EMBedding<group>.....        | 862 |
| MMEMory:LOAD:VNETworks<Ch>:PPAIr:DEEMbedding<ListId>.....     | 863 |
| MMEMory:LOAD:VNETworks<Ch>:PPAIr:EMBedding<ListId>.....       | 863 |
| MMEMory:LOAD:VNETworks<Ch>:SENDEd:DEEMbedding<PhyPt>.....     | 865 |
| MMEMory:LOAD:VNETworks<Ch>:SENDEd:EMBedding<PhyPt>.....       | 865 |
| MMEMory:MDIRectory.....                                       | 865 |
| MMEMory:MOVE.....                                             | 866 |
| MMEMory:MSIS.....                                             | 866 |
| MMEMory:NAME.....                                             | 867 |
| MMEMory:RDIRectory.....                                       | 867 |
| MMEMory:STORE:CABLe.....                                      | 867 |
| MMEMory:STORE:CKIT.....                                       | 868 |
| MMEMory:STORE:CKIT:WLABel.....                                | 868 |
| MMEMory:STORE:CMAPI.....                                      | 869 |
| MMEMory:STORE:CORRection.....                                 | 869 |
| MMEMory:STORE:CORRection:TCOefficient<Ch>.....                | 870 |
| MMEMory:STORE:LIMit.....                                      | 870 |
| MMEMory:STORE:MARKer.....                                     | 870 |
| MMEMory:STORE:RIPPIle.....                                    | 871 |

|                                                                    |      |
|--------------------------------------------------------------------|------|
| MMEMory:STORe:SEGMENT.....                                         | 871  |
| MMEMory:STORe:STATe.....                                           | 872  |
| MMEMory:STORe:TRACe.....                                           | 872  |
| MMEMory:STORe:TRACe:CHANnel.....                                   | 873  |
| MMEMory:STORe:TRACe:OPTion:BALanced.....                           | 875  |
| MMEMory:STORe:TRACe:OPTion:COMMeNt.....                            | 875  |
| MMEMory:STORe:TRACe:OPTion:DECimals:DATA.....                      | 875  |
| MMEMory:STORe:TRACe:OPTion:DECimals:STIMulus.....                  | 875  |
| MMEMory:STORe:TRACe:OPTion:FORMat.....                             | 876  |
| MMEMory:STORe:TRACe:OPTion:PLUS.....                               | 876  |
| MMEMory:STORe:TRACe:OPTion:SSEParator.....                         | 876  |
| MMEMory:STORe:TRACe:OPTion:SYMMetric.....                          | 875  |
| MMEMory:STORe:TRACe:OPTion:TABS.....                               | 876  |
| MMEMory:STORe:TRACe:OPTion:TRIM.....                               | 877  |
| MMEMory:STORe:TRACe:PORTs.....                                     | 877  |
| OUTPut:UPORt:ECBits.....                                           | 878  |
| OUTPut<Ch>:UPORt:SEGMeNt<Seg>:STATe.....                           | 879  |
| OUTPut<Ch>:UPORt:SEGMeNt<Seg>[:VALue].....                         | 879  |
| OUTPut<Ch>:UPORt[:VALue].....                                      | 881  |
| OUTPut<Ch>[:STATe].....                                            | 878  |
| OUTPut<Chn>:DPORT.....                                             | 1096 |
| PROGrama[:SELeCted]:EXECute.....                                   | 883  |
| PROGrama[:SELeCted]:INIMeSSage.....                                | 884  |
| PROGrama[:SELeCted]:INIParaMeTer.....                              | 884  |
| PROGrama[:SELeCted]:NAME.....                                      | 885  |
| PROGrama[:SELeCted]:RETVal?.....                                   | 886  |
| PROGrama[:SELeCted]:WAIT.....                                      | 886  |
| SOURce:POWer:CORRection:COLLect:VNETworks.....                     | 1002 |
| SOURce:POWer:CORRection:PMETer:ID.....                             | 994  |
| SOURce:POWer:CORRection:PPOWer.....                                | 1004 |
| SOURce:POWer:REDuce:SDELay.....                                    | 1010 |
| SOURce:POWer:SWEpend:MODE.....                                     | 1010 |
| SOURce:POWer:SWEpend:SDELay.....                                   | 1010 |
| SOURce<Ch>:FREQuency<PhyPt>:FIXed.....                             | 989  |
| SOURce<Ch>:FREQuency<PhyPt>[:CW].....                              | 989  |
| SOURce<Ch>:GROup<Grp>.....                                         | 992  |
| SOURce<Ch>:GROup<Grp>:CLEar.....                                   | 992  |
| SOURce<Ch>:GROup<Grp>:PORTs.....                                   | 993  |
| SOURce<Ch>:GROup<Grp>:PPORts.....                                  | 993  |
| SOURce<Ch>:LPORt<LogPt>.....                                       | 990  |
| SOURce<Ch>:LPORt<LogPt>:CLEar.....                                 | 991  |
| SOURce<Ch>:POWer:CORRection:DATA.....                              | 995  |
| SOURce<Ch>:POWer:CORRection:DATA:PARaMeTer<Wv>?.....               | 996  |
| SOURce<Ch>:POWer<PhyPt>:CORRection:COLLect:AVERAge:NTOLerance..... | 999  |
| SOURce<Ch>:POWer<PhyPt>:CORRection:COLLect:AVERAge[:COUNt].....    | 999  |
| SOURce<Ch>:POWer<PhyPt>:CORRection:COLLect:CFACtor.....            | 1000 |
| SOURce<Ch>:POWer<PhyPt>:CORRection:COLLect:FLATneSS.....           | 1000 |
| SOURce<Ch>:POWer<PhyPt>:CORRection:COLLect:METhod.....             | 1001 |
| SOURce<Ch>:POWer<PhyPt>:CORRection:COLLect:RRECeiver.....          | 1002 |
| SOURce<Ch>:POWer<PhyPt>:CORRection:COLLect[:ACQuire].....          | 1107 |

|                                                                        |      |
|------------------------------------------------------------------------|------|
| SOURce<Ch>:POWER<PhyPt>:CORRection:DATA:PARAmeter<Wv>:COUNT?           | 1003 |
| SOURce<Ch>:POWER<PhyPt>:CORRection:LEVel:OFFSet                        | 1013 |
| SOURce<Ch>:POWER<PhyPt>:CORRection:NREadings                           | 1003 |
| SOURce<Ch>:POWER<PhyPt>:CORRection:OSources[:STATe]                    | 1003 |
| SOURce<Ch>:POWER<PhyPt>:CORRection:PSElect                             | 1004 |
| SOURce<Ch>:POWER<PhyPt>:CORRection:STATe                               | 1005 |
| SOURce<Ch>:POWER<PhyPt>:CORRection:TCoefficient:CALibration            | 1005 |
| SOURce<Ch>:POWER<PhyPt>:CORRection:TCoefficient:COUNT?                 | 1007 |
| SOURce<Ch>:POWER<PhyPt>:CORRection:TCoefficient:DEFine<ListNo>         | 1007 |
| SOURce<Ch>:POWER<PhyPt>:CORRection:TCoefficient:DELeTe<ListNo>:ALL     | 1008 |
| SOURce<Ch>:POWER<PhyPt>:CORRection:TCoefficient:DELeTe<ListNo>[:DUMMy] | 1008 |
| SOURce<Ch>:POWER<PhyPt>:CORRection:TCoefficient:FEED                   | 1008 |
| SOURce<Ch>:POWER<PhyPt>:CORRection:TCoefficient:INSert<ListNo>         | 1009 |
| SOURce<Ch>:POWER<PhyPt>:CORRection:TCoefficient[:STATe]                | 1005 |
| SOURce<Ch>:POWER<PhyPt>:CORRection[:ACQuire]                           | 997  |
| SOURce<Ch>:POWER<PhyPt>:CORRection[:ACQuire]:VERification:RESult?      | 998  |
| SOURce<Ch>:POWER<PhyPt>:REDuce[:STATe]                                 | 1013 |
| SOURce<Ch>:POWER<PhyPt>:START                                          | 1014 |
| SOURce<Ch>:POWER<PhyPt>:STATe                                          | 1014 |
| SOURce<Ch>:POWER<PhyPt>:STOP                                           | 1014 |
| SOURce<Ch>:POWER<PhyPt>[:LEVel][:IMMediate]:OFFSet                     | 1011 |
| SOURce<Ch>:POWER<PhyPt>[:LEVel][:IMMediate]:SLOPe                      | 1012 |
| SOURce<Ch>:POWER<PhyPt>[:LEVel][:IMMediate][:AMPLitude]                | 1011 |
| STATus:PRESet                                                          | 1016 |
| STATus:QUEStionable:CONDition?                                         | 1016 |
| STATus:QUEStionable:ENABLE                                             | 1017 |
| STATus:QUEStionable:INTegrity:CONDition?                               | 1016 |
| STATus:QUEStionable:INTegrity:ENABLE                                   | 1017 |
| STATus:QUEStionable:INTegrity:HARDware:CONDition?                      | 1016 |
| STATus:QUEStionable:INTegrity:HARDware:ENABLE                          | 1017 |
| STATus:QUEStionable:INTegrity:HARDware:NTRansition                     | 1017 |
| STATus:QUEStionable:INTegrity:HARDware:PTRansition                     | 1018 |
| STATus:QUEStionable:INTegrity:HARDware[:EVENT]?                        | 1016 |
| STATus:QUEStionable:INTegrity:NTRansition                              | 1017 |
| STATus:QUEStionable:INTegrity:PTRansition                              | 1018 |
| STATus:QUEStionable:INTegrity[:EVENT]?                                 | 1016 |
| STATus:QUEStionable:LIMit<Lev>:CONDition?                              | 1016 |
| STATus:QUEStionable:LIMit<Lev>:ENABLE                                  | 1017 |
| STATus:QUEStionable:LIMit<Lev>:NTRansition                             | 1017 |
| STATus:QUEStionable:LIMit<Lev>:PTRansition                             | 1018 |
| STATus:QUEStionable:LIMit<Lev>[:EVENT]?                                | 1016 |
| STATus:QUEStionable:NTRansition                                        | 1017 |
| STATus:QUEStionable:PTRansition                                        | 1018 |
| STATus:QUEStionable[:EVENT]?                                           | 1016 |
| STATus:QUEue[:NEXT]?                                                   | 1018 |
| SYSTem:AGC:GLOBal:METHod                                               | 1041 |
| SYSTem:COMMunicate:AKAL:CONNection                                     | 1019 |
| SYSTem:COMMunicate:AKAL:MMEMory[:STATe]                                | 1020 |
| SYSTem:COMMunicate:CODec                                               | 1020 |
| SYSTem:COMMunicate:GPIB[:SELF]:ADDResS                                 | 1021 |

|                                                                    |      |
|--------------------------------------------------------------------|------|
| SYSTem:COMMunicate:GPIB[:SELF]:DClear:SUPPress.....                | 1021 |
| SYSTem:COMMunicate:GPIB[:SELF]:INIT:WAIT.....                      | 1021 |
| SYSTem:COMMunicate:GPIB[:SELF]:LPORt:ALIGn.....                    | 1021 |
| SYSTem:COMMunicate:GPIB[:SELF]:RTERminator.....                    | 1022 |
| SYSTem:COMMunicate:NET:HOSTname.....                               | 1022 |
| SYSTem:COMMunicate:RDEvice:AKAL:ADDResS.....                       | 1023 |
| SYSTem:COMMunicate:RDEvice:AKAL:ADDResS:ALL?.....                  | 1023 |
| SYSTem:COMMunicate:RDEvice:AKAL:CKIT:CATalog?.....                 | 1023 |
| SYSTem:COMMunicate:RDEvice:AKAL:CKIT:STANdard:CATalog?.....        | 1024 |
| SYSTem:COMMunicate:RDEvice:AKAL:DATE?.....                         | 1025 |
| SYSTem:COMMunicate:RDEvice:AKAL:FRANge?.....                       | 1025 |
| SYSTem:COMMunicate:RDEvice:AKAL:PORtS?.....                        | 1026 |
| SYSTem:COMMunicate:RDEvice:AKAL:PREdUction[:STATe].....            | 1026 |
| SYSTem:COMMunicate:RDEvice:AKAL:SDATA?.....                        | 1026 |
| SYSTem:COMMunicate:RDEvice:AKAL:WARMup[:STATe]?.....               | 1027 |
| SYSTem:COMMunicate:RDEvice:PMETer:CATalog?.....                    | 1027 |
| SYSTem:COMMunicate:RDEvice:PMETer:CONFIgure:AUTO[:STATe].....      | 1028 |
| SYSTem:COMMunicate:RDEvice:PMETer:COUNT?.....                      | 1028 |
| SYSTem:COMMunicate:RDEvice:PMETer:DELeTe.....                      | 1028 |
| SYSTem:COMMunicate:RDEvice:PMETer<Pmtr>:AZERo.....                 | 1029 |
| SYSTem:COMMunicate:RDEvice:PMETer<Pmtr>:DEFine.....                | 1029 |
| SYSTem:COMMunicate:RDEvice:PMETer<Pmtr>:SPCorrecTion[:STATe].....  | 1030 |
| SYSTem:COMMunicate:RDEvice:SMATrix:CONFIgure:ABORt.....            | 1031 |
| SYSTem:COMMunicate:RDEvice:SMATrix:CONFIgure:END.....              | 1031 |
| SYSTem:COMMunicate:RDEvice:SMATrix:CONFIgure:STARt.....            | 1032 |
| SYSTem:COMMunicate:RDEvice:SMATrix:CONFIgure:TVNA.....             | 1033 |
| SYSTem:COMMunicate:RDEvice:SMATrix:COUNT?.....                     | 1033 |
| SYSTem:COMMunicate:RDEvice:SMATrix:DELeTe.....                     | 1033 |
| SYSTem:COMMunicate:RDEvice:SMATrix:SCAN?.....                      | 1033 |
| SYSTem:COMMunicate:RDEvice:SMATrix<Matr>:CATalog?.....             | 1030 |
| SYSTem:COMMunicate:RDEvice:SMATrix<Matr>:CONFIgure:MLTest.....     | 1035 |
| SYSTem:COMMunicate:RDEvice:SMATrix<Matr>:CONFIgure:MLVNa.....      | 1035 |
| SYSTem:COMMunicate:RDEvice:SMATrix<Matr>:CONFIgure:MTESt.....      | 1036 |
| SYSTem:COMMunicate:RDEvice:SMATrix<Matr>:CONFIgure:MVNA.....       | 1036 |
| SYSTem:COMMunicate:RDEvice:SMATrix<Matr>:DEFine.....               | 1034 |
| SYSTem:COMMunicate:RDEvice:SMATrix<Matr>:RELays:SWITCh:COUNT?..... | 1037 |
| SYSTem:COMMunicate:RDEvice:SMATrix<Matr>:SERial?.....              | 1037 |
| SYSTem:COMMunicate:REST:ENABle.....                                | 1071 |
| SYSTem:COMMunicate:SNMP:COMMunity:RO.....                          | 1068 |
| SYSTem:COMMunicate:SNMP:COMMunity:RW.....                          | 1068 |
| SYSTem:COMMunicate:SNMP:CONtact.....                               | 1069 |
| SYSTem:COMMunicate:SNMP:LOCation.....                              | 1069 |
| SYSTem:COMMunicate:SNMP:USM:USER.....                              | 1069 |
| SYSTem:COMMunicate:SNMP:USM:USER:ALL?.....                         | 1070 |
| SYSTem:COMMunicate:SNMP:USM:USER:DELeTe.....                       | 1070 |
| SYSTem:COMMunicate:SNMP:USM:USER:DELeTe:ALL.....                   | 1070 |
| SYSTem:COMMunicate:SNMP:VERsion.....                               | 1070 |
| SYSTem:CORRection:WIZard[:IMMEdiate].....                          | 1041 |
| SYSTem:DATA:MEMory:ADD.....                                        | 1038 |
| SYSTem:DATA:MEMory:CATalog?.....                                   | 1038 |

|                                                |      |
|------------------------------------------------|------|
| SYSTem:DATA:MEMory:COMMit.....                 | 1038 |
| SYSTem:DATA:MEMory:DELeTe.....                 | 1039 |
| SYSTem:DATA:MEMory:INIAlize.....               | 1039 |
| SYSTem:DATA:MEMory:OFFSet?.....                | 1039 |
| SYSTem:DATA:MEMory:RESet.....                  | 1040 |
| SYSTem:DATA:MEMory:SIZE?.....                  | 1040 |
| SYSTem:DATE.....                               | 1042 |
| SYSTem:DFPRint?.....                           | 1042 |
| SYSTem:DISPlay:BAR:HKEY[:STATe].....           | 1042 |
| SYSTem:DISPlay:BAR:MENU[:STATe].....           | 1042 |
| SYSTem:DISPlay:BAR:STATus[:STATe].....         | 1042 |
| SYSTem:DISPlay:BAR:STOols[:STATe].....         | 1042 |
| SYSTem:DISPlay:BAR:TITLe[:STATe].....          | 1042 |
| SYSTem:DISPlay:BAR:TOOLs[:STATe].....          | 1042 |
| SYSTem:DISPlay:COLor.....                      | 1043 |
| SYSTem:DISPlay:CONDuctances.....               | 1043 |
| SYSTem:DISPlay:DIALogs:SETup:MCAL[:STATe]..... | 1043 |
| SYSTem:DISPlay:TRACes:CCOunt.....              | 1043 |
| SYSTem:DISPlay:UPDate.....                     | 1044 |
| SYSTem:ERRor:ALL?.....                         | 1044 |
| SYSTem:ERRor:COUnT?.....                       | 1044 |
| SYSTem:ERRor:DISPlay:ERRor.....                | 1045 |
| SYSTem:ERRor:DISPlay:INFO.....                 | 1045 |
| SYSTem:ERRor:DISPlay:STATe.....                | 1046 |
| SYSTem:ERRor:DISPlay:WARNings.....             | 1045 |
| SYSTem:ERRor:DISPlay[:REMOte].....             | 1045 |
| SYSTem:ERRor[:NEXT]?.....                      | 1044 |
| SYSTem:FIRMWare:UPDate.....                    | 1046 |
| SYSTem:FPReset.....                            | 1046 |
| SYSTem:FREQuency?.....                         | 1047 |
| SYSTem:HELP:HEADers?.....                      | 1047 |
| SYSTem:HELP:SYNTax:ALL?.....                   | 1048 |
| SYSTem:HELP:SYNTax?.....                       | 1047 |
| SYSTem:IDENtify:FACTory.....                   | 1048 |
| SYSTem:IDENtify[:STRing].....                  | 1048 |
| SYSTem:KLOCK.....                              | 1048 |
| SYSTem:LANGuage.....                           | 1049 |
| SYSTem:LOGGing:REMOte[:STATe].....             | 1049 |
| SYSTem:OPTions:FACTory.....                    | 1049 |
| SYSTem:OPTions[:STRing].....                   | 1050 |
| SYSTem:PASSword[:CENable].....                 | 1050 |
| SYSTem:PRESet:REMOte[:STATe].....              | 1050 |
| SYSTem:PRESet:SCOPE.....                       | 1051 |
| SYSTem:PRESet:START.....                       | 1051 |
| SYSTem:PRESet:USER:CAL.....                    | 1052 |
| SYSTem:PRESet:USER:NAME.....                   | 1052 |
| SYSTem:PRESet:USER[:STATe].....                | 1051 |
| SYSTem:PRESet[:DUMMy].....                     | 1050 |
| SYSTem:SETTings:UPDate.....                    | 1053 |
| SYSTem:SHUTdown.....                           | 1054 |



|                                                 |      |
|-------------------------------------------------|------|
| SYSTem:SMATrix:OPTimization.....                | 1053 |
| SYSTem:SOUNd:ALARm[:STATe].....                 | 1054 |
| SYSTem:SOUNd:STATus[:STATe].....                | 1054 |
| SYSTem:TIME.....                                | 1054 |
| SYSTem:TRESet[:STATe].....                      | 1055 |
| SYSTem:TSLock.....                              | 1055 |
| SYSTem:TTLout<Pt>:STATus[:STATe].....           | 1055 |
| SYSTem:USER:DISPlay:TITLe.....                  | 1056 |
| SYSTem:USER:KEY.....                            | 1056 |
| SYSTem:VERSIon?.....                            | 1057 |
| TRACe:CLEar.....                                | 1108 |
| TRACe:COPIY.....                                | 1058 |
| TRACe:COPIY:MATH.....                           | 1059 |
| TRACe[:DATA]:STIMulus[:ALL]?.....               | 1109 |
| TRACe[:DATA]:RESPonse[:ALL]?.....               | 1108 |
| TRIGger:CHANnel<Ch>:AUXiliary<n>:DURation.....  | 1065 |
| TRIGger:CHANnel<Ch>:AUXiliary<n>:INTerval.....  | 1066 |
| TRIGger:CHANnel<Ch>:AUXiliary<n>:OPOLarity..... | 1066 |
| TRIGger:CHANnel<Ch>:AUXiliary<n>:POSition.....  | 1067 |
| TRIGger:CHANnel<Ch>:AUXiliary<n>[:ENABLE].....  | 1065 |
| TRIGger<Ch>[:SEQuence]:HOLDoff.....             | 1061 |
| TRIGger<Ch>[:SEQuence]:LINK.....                | 1061 |
| TRIGger<Ch>[:SEQuence]:MULTiple:HOLDoff.....    | 1062 |
| TRIGger<Ch>[:SEQuence]:MULTiple:SLOPe<Num>..... | 1062 |
| TRIGger<Ch>[:SEQuence]:MULTiple:SOURce.....     | 1063 |
| TRIGger<Ch>[:SEQuence]:SLOPe.....               | 1063 |
| TRIGger<Ch>[:SEQuence]:SOURce.....              | 1064 |

# Index

## Symbols

|                           |          |
|---------------------------|----------|
| -Z14 .....                | 1161     |
| @DCL .....                | 1157     |
| @GET .....                | 1157     |
| @LOC .....                | 1157     |
| @REM .....                | 1157     |
| *.csv file format .....   | 137      |
| *.limit .....             | 128      |
| *.ripple .....            | 129      |
| *.s<n>p file format ..... | 130      |
| *CLS .....                | 592, 596 |
| *ESE .....                | 596      |
| *ESR? .....               | 596      |
| *IDN? .....               | 596      |
| *IST? .....               | 596      |
| *OPC .....                | 596      |
| *OPC (use) .....          | 590      |
| *OPT? .....               | 597      |
| *PCB .....                | 597      |
| *PRE .....                | 597      |
| *PSC .....                | 597      |
| *RST .....                | 597      |
| *SRE .....                | 597      |
| *STB? .....               | 597      |
| *TRG .....                | 597      |
| *WAI .....                | 597      |
| μ1 21 (softkey) .....     | 246      |
| μ2 21 (softkey) .....     | 246      |

## A

|                                         |           |
|-----------------------------------------|-----------|
| a1 Source Port 1 .....                  | 234       |
| a2 Source Port 2 .....                  | 234       |
| AC Supply .....                         | 23        |
| Accessories (connect) .....             | 24        |
| Active Diagram .....                    | 504       |
| Active Power Cals dialog .....          | 422       |
| Active Trace .....                      | 265       |
| Add Device .....                        |           |
| external power meters .....             | 545       |
| external switch matrices .....          | 550       |
| Add Tr+Diag .....                       | 266       |
| Add Trace .....                         | 265       |
| Additional Removable System Drive ..... | 207       |
| Addressed command .....                 | 565, 1160 |
| Adjust Time Gate .....                  | 445       |
| Administrative tasks .....              | 1149      |
| Admittance .....                        | 111       |
| Advanced (system settings) .....        | 526       |
| All Channels Continuous .....           | 372       |
| All Channels on Hold .....              | 372       |
| All Data & Func to <Destination> .....  | 272       |
| All Data to <Destination> .....         | 272       |
| All Partial Meas'ments .....            | 354       |
| All S-Params .....                      | 223       |
| Annexes .....                           | 1149      |
| Aperture .....                          | 121       |
| Aperture Points .....                   | 257       |
| Applic softtool .....                   | 493       |
| External Tools application .....        | 493       |
| Application cards .....                 | 14        |
| Application notes .....                 | 14        |

## Apply

|                                       |      |
|---------------------------------------|------|
| System error correction .....         | 392  |
| Apply (calibration) .....             | 394  |
| ASCII .....                           | 518  |
| ASCII (*.csv) file .....              | 137  |
| ATN .....                             | 1159 |
| Attention .....                       | 1159 |
| Auto Config .....                     | 546  |
| Auto Length .....                     | 446  |
| Auto Length and Loss .....            | 450  |
| Auto Power Setting for Cal Unit ..... | 521  |
| Auto scale .....                      | 57   |
| Auto Scale Diagram .....              | 260  |
| Auto Scale Trace .....                | 260  |
| Auto Zero .....                       | 247  |
| Automatic calibration .....           | 159  |
| Automatic Harmonic Grid .....         | 283  |
| Average .....                         | 351  |
| Average tab .....                     | 350  |
| Averaging mode .....                  | 351  |
| Auto .....                            | 351  |
| Flatten Noise .....                   | 351  |
| Moving Average .....                  | 351  |
| Reduce Noise .....                    | 351  |
| Axis Pair .....                       | 285  |

## B

|                                   |         |
|-----------------------------------|---------|
| b1 / a1 Source Port 1 .....       | 231     |
| b1 / a2 Source Port 2 .....       | 231     |
| b1 Source Port 1 .....            | 234     |
| b1 Source Port 2 .....            | 234     |
| b2 / a1 Source Port 1 .....       | 231     |
| b2 / a2 Source Port 2 .....       | 231     |
| b2 Source Port 1 .....            | 234     |
| b2 Source Port 2 .....            | 234     |
| Balanced port .....               | 116     |
| Balanced Ports dialog .....       | 226     |
| Logical Port Config tab .....     | 227     |
| Predefined Config tab .....       | 226     |
| Reference Impedance tab .....     | 229     |
| User Config tab .....             | 228     |
| Band pass impulse .....           | 194     |
| Bandfilter search .....           | 89, 337 |
| Bandpass Ref to Max .....         | 339     |
| Bandpass Ref to Mkr .....         | 339     |
| Bandstop Ref to Max .....         | 340     |
| Bandwidth .....                   | 338     |
| Result Off .....                  | 340     |
| Search bandpass or bandstop ..... | 341     |
| Search Mode .....                 | 341     |
| Tracking .....                    | 341     |
| Bandpass .....                    | 89      |
| Bandpass (time gate) .....        | 285     |
| Bandstop .....                    | 89      |
| Bandwidth .....                   | 350     |
| Bandwidth (bandfilter) .....      | 90      |
| Bandwidth tab .....               | 349     |
| Basic instrument concepts .....   | 69      |
| Basic Measurement Examples .....  |         |
| see User Manual .....             | 13      |
| Basic tasks .....                 | 35      |
| Bench Top Operation .....         | 21      |

- Black White Scheme ..... 514
- Block data format ..... 569
- Boolean parameter ..... 569
- Brochures ..... 14
- Buffered Sweep ..... 1133
- C**
- Cal Connector Types dialog ..... 401
  - Char. Imp. .... 402
  - Cutoff Freq. fc ..... 403
  - Line Type ..... 403
  - Offset model ..... 403
  - Rel. Permittivity  $\epsilon_r$  ..... 403
- Cal group ..... 158
- Cal Kit
  - Import ..... 389
  - Selection ..... 389
- Cal kit file ..... 157
- Cal Kits
  - Calibration Setting wizard ..... 387
- Cal Power Offset ..... 418
- Cal softtool ..... 374
  - Cal Devices tab ..... 400
  - Pwr Cal Settings tab ..... 414
  - Start Cal tab ..... 374
  - Use Cal tab ..... 421
- Cal Unit
  - Calibration ..... 378
  - Characterization ..... 379
- Cal Validation info ..... 536
- Calibrate all Channels ..... 387
- Calibration ..... 140, 374, 1135
  - Cal Devices ..... 400
  - Cal Unit ..... 378
  - Cal Unit Characterization ..... 379
  - Calibrate all Channels ..... 387
  - Devices ..... 400
  - Manual ..... 385
  - Ports ..... 378, 386
  - Power calibration settings ..... 414
  - Procedure ..... 374
  - program example ..... 1135
  - Source port ..... 387
  - Sweep diagrams ..... 383, 390
  - Type ..... 379, 387
  - Validation ..... 163
- Calibration (manual)
  - Connector ..... 388
  - Same Connector All Ports ..... 389
  - Same Gender All Ports ..... 389
  - Sweep ..... 391
- Calibration (system settings) ..... 521
- Calibration kit ..... 152
- Calibration Kits dialog ..... 404
  - Add cal kit ..... 405
  - Available Cal Kits ..... 405
  - Connector Type ..... 405
  - Copy cal kit ..... 405
  - Delete cal kit ..... 405
  - Export Cal Kit... ..... 405
  - Import Cal Kit... ..... 405
  - Standards... ..... 405
- Calibration labels
  - scalar power calibration ..... 170
  - system error correction ..... 158
- Calibration Manager dialog ..... 423, 424
  - Add ..... 424
  - Apply ..... 424
  - Apply to All ..... 424
  - Channel and calibration properties ..... 426
  - Channel State ..... 424
  - Delete from Pool ..... 425
  - Pool ..... 425
  - Preset User Cal ..... 425
  - Replace ..... 424
  - Resolve Pool Link ..... 425
- Calibration pool ..... 158
- Calibration Setting wizard ..... 385
  - Apply ..... 392
  - Cal Kit ..... 389
  - Calibration ..... 389
  - Connectors and Cal Kits ..... 387
  - Ports and Type ..... 385
- Calibration standard ..... 152
- Calibration types ..... 141
- Calibration unit ..... 159, 163
- Calibration Unit
  - Default Port Assignment ..... 382
  - Detect Port Assignment ..... 382, 384
  - Detect Ports & Start Cal ..... 384
- Calibration Unit wizard ..... 376
  - Calibration Type ..... 379
- Cartesian diagram ..... 95
- CENTER ..... 76
- Center (bandfilter) ..... 90
- Center = Marker ..... 342
- Center Frequency ..... 346
- Channel ..... 70, 266
  - programming examples ..... 1113
- CHANNEL ..... 30
- Channel Bits (system settings) ..... 525
  - Decimal ..... 526
  - Pin 16 - 19 ..... 526
- Channel Config
  - Port Config ..... 430
  - Port Settings ..... 431
- Channel Config softtool ..... 426
  - Channels tab ..... 426
  - Mode tab ..... 432
  - Port Config tab ..... 430
  - Pwr Cal Settings tab ..... 434
- Channel Info ..... 510
- Channel Manager dialog ..... 429
  - Add channel ..... 430
  - Channel table ..... 429
  - Delete channel ..... 430
- Channel properties ..... 426
- Channel settings ..... 90
- Channels tab
  - Active Channel ..... 427
  - Channel Manager... ..... 429
  - Channel On ..... 429
  - Controls ..... 427
  - Copy Channel ..... 428
  - Copy Channel + Diagram ..... 428
  - Delete Channel ..... 428
  - Fixture Simulator ..... 429
  - New Channel ..... 427
  - New Channel + Diagram ..... 428
- Characterization
  - Cal Unit ..... 379
- Characterization Data ..... 410

- Characterization wizard ..... 411
    - Test Port Assignment ..... 412
  - Characterize Cal Unit dialog ..... 409
    - Authentication ..... 410
    - Set Password ..... 410
  - Chirp z-transformation ..... 193
  - Circle limit ..... 126
  - Circle Test ..... 317
    - Clear Test ..... 320
    - Define circle ..... 320
    - Draw Circle ..... 320
    - Limit Check ..... 318
    - Limit Fail Beep ..... 320
    - Show Limit Circle ..... 318
  - Circular diagrams ..... 58
  - Cleaning ..... 1170
  - CMRR measurement ..... 243
  - CMRR12 (softkey) ..... 244
  - CMRR21 (softkey) ..... 244
  - Color Scheme ..... 509
  - Colorize Trace when Failed ..... 512
  - Command
    - common ..... 566
    - device-specific ..... 566
    - processing ..... 576
    - recognition ..... 576
    - sequence ..... 576
    - structure and syntax ..... 566
    - synchronization ..... 576
  - Command reference ..... 597
  - Common commands ..... 594, 596
  - Common mode ..... 115, 117
  - Common Mode ..... 230
  - Compatibility mode
    - Sweep Active Channel ..... 374
    - Sweep All Channels ..... 373
  - Computer name
    - Changing ..... 1153
  - CONDition ..... 581, 582
  - Configured devices
    - external power meters ..... 544
    - external switch matrices ..... 549
  - Connectors ..... 1155
    - Calibration Setting wizard ..... 387
  - Context menu ..... 91
  - Continuous sweep ..... 370
  - Control bus ..... 1159
  - Control elements ..... 40
  - Control lines (GPIB bus) ..... 1158
  - Couple Active Trace ..... 262
  - Couple All Traces ..... 262
  - Customer support ..... 1148
  - CW Frequency ..... 346
  - CW Mode sweep ..... 358
- D**
- Data & Func to <Destination> ..... 271
  - Data base ..... 576
  - Data bus (GPIB) ..... 1158
  - Data entry ..... 51
  - DATA ENTRY ..... 31
  - Data flow ..... 77
  - Data sheets ..... 14
  - Data to <Destination> ..... 271
  - Data Valid ..... 1159
  - DAV ..... 1159
  - dB Mag ..... 253
  - DC Value ..... 283
  - DCL ..... 1157, 1160
  - DCL, SDC ..... 592
  - Decouple Active Trace ..... 262
  - Decouple All Traces ..... 262
  - Deembedding
    - Balanced ..... 439, 440
    - Ground Loop ..... 441
    - Impedance Renormalization ..... 441, 442
    - Port Sets ..... 437, 439
    - Single Ended ..... 437
  - DEfault ..... 569
  - Default file locations ..... 841
  - Default Port Assignment ..... 382
  - Define Limit Lines dialog ..... 308
  - Define Ripple Test dialog ..... 315
  - Define Segments dialog ..... 360
    - Displayed Columns ..... 363
  - Define User Color Scheme dialog ..... 511
  - Delay ..... 121
  - Delay (Offset Embed) ..... 444, 445
  - Delete All Cal Kits ..... 522
  - Delete All Mem ..... 273
  - Delete Cal Pool ..... 522
  - Delete Trace ..... 266
  - Delta Mode ..... 325
  - Delta-L 4.0 PCB characterization ..... 204
  - Denominator ..... 233
  - Destination (memory trace) ..... 271
  - Destination (memory traces) ..... 273
  - Detector ..... 114
  - Device address ..... 564
  - Device LAN configuration dialog ..... 551
  - Device message ..... 565
  - Device response ..... 565
  - Dflt Marker Frmt ..... 259
  - DHCP server
    - LAN configuration ..... 1153
  - Diagram ..... 47, 70, 266, 503
    - Active Diagram ..... 504
    - Add Tr+Diag ..... 504
    - Delete Diagram ..... 505
    - Maximize Diagram ..... 505
    - Name ..... 505
    - Overlay All ..... 505
    - programming examples ..... 1113
    - Show Title ..... 505
    - Title ..... 505
    - Trace List ..... 504
  - Dialog ..... 92
  - Dialogs ..... 46
  - Differential imbalance measurement ..... 244
  - Differential mode ..... 115, 117
  - Differential Mode ..... 230
  - Display ..... 29
    - Diagram ..... 503
  - Display Circle ..... 321
  - Display Config ..... 509
    - Channel Info ..... 510
    - Color Scheme ..... 509
    - Font Size ..... 511
    - Hide Sensitive Information ..... 510
    - Info Table ..... 510
    - Trace Info ..... 510
  - Display elements ..... 81

- Display softtool ..... 503
  - Config tab ..... 509
  - Diagram tab ..... 503
  - Split tab ..... 506
  - Touchscreen tab ..... 517
  - View Bar tab ..... 516
- Displayed Columns dialog ..... 363
- Distance Center ..... 348
- Distance Span ..... 348
- Distance Start ..... 348
- Distance Stop ..... 348
- Distance to Fault
  - Sweep points ..... 497
  - Window ..... 496
- Distance to Fault (R&S ZND-K3) ..... 495
- Distance to Fault App ..... 495
- Distance-to-fault measurements
  - Option R&S ZND-K3 ..... 200
- DNS server
  - LAN configuration ..... 1153
- Dolph-Chebyshev
  - Side Lobe Level ..... 281
- DOWN ..... 569
- Drag and drop ..... 50
- Driver (remote control) ..... 560
- Driving Mode
  - Alternated ..... 433
  - Auto ..... 433
  - Chopped ..... 433
- E**
- Eazy De-embedding ..... 202
- Electrical Length ..... 121, 444, 445
- Electrostatic discharge ..... 21
- Electrostatic discharge (ESD) ..... 34
- Embedding
  - Balanced ..... 439, 440
  - Differential Match ..... 442
  - Ground Loop ..... 441
  - Impedance Renormalization ..... 441, 442
  - Port Sets ..... 437, 439
  - Single Ended ..... 437
- EMI suppression ..... 22
- ENABLE ..... 580, 581
- EOI ..... 1159
- Error log ..... 536
- Error message ..... 1143
- Error queue ..... 580, 592
- Errors ..... 1143
  - Asynchronous ..... 1144
  - During firmware update ..... 1145
  - During measurement ..... 1144
  - FPGA update ..... 1145
- ESB ..... 584
- ESD ..... 21
- ESE ..... 580, 585
- ESR ..... 585
- Evaluation of data ..... 65
- Evaluation Range Dialog ..... 291
- EVENT register ..... 581
- Execution (command)
  - overlapping ..... 576
  - sequential ..... 576
- Export
  - Sweep segments ..... 363
- Export Data - <File Type> dialog ..... 298
  - Ask Before Overwriting ..... 300
  - Comment Added to File ..... 302
  - Contents ..... 300
  - Output Format ..... 300
- Export Data - ASCII Files dialog
  - Add Ref Impedances ..... 301
  - Decimal Separator ..... 302
  - Field Separator ..... 302
  - Formatted Values ..... 301
- Export Data - MatLab Files dialog
  - Add Ref Impedances ..... 301
  - Field Separator ..... 302
  - Formatted Values ..... 301
- Export Data - Touchstone Files dialog
  - Normalize with Port-Specific Impedances ..... 300
  - Symmetric Params ..... 300
- Export Markers ..... 328
- Export snp Files
  - Active Channel ..... 303
  - All Channels ..... 303
  - Assign port numbers ..... 303
  - Reset Port Assignments ..... 304
  - Select ports ..... 303
  - Select Ports ..... 303
- EXT TRIG IN ..... 1157
- EXT TRIG OUT ..... 1157
- EXT TRIG OUT / IN ..... 34
- Extended Power Range ..... 207
- External Devices ..... 541
- External Frequency ..... 539
- External Matrices dialog ..... 548
- External Ports ..... 547
- External power meter ..... 208
- External Power Meter Config dialog ..... 546
- External Power Meters dialog ..... 543
- External reference ..... 538
- EZD
  - Advanced settings ..... 466
- F**
- Factor (averaging) ..... 351
- Factory calibration ..... 1150
- Favorites ..... 489
- File softtool ..... 484
  - Favorites tab ..... 489
  - More tab ..... 493
  - Print tab ..... 490
  - Recall Sets tab ..... 485
  - Trace Data tab ..... 492
- Firewall ..... 1154
- Firmware
  - Setup file ..... 1150
- Firmware installation ..... 1150
- First Partial Meas'ment ..... 354
- Fixture Compensation
  - Auto Length ..... 447
  - Auto Length and Loss ..... 447
  - Direct Compensation ..... 448
- Fixture Compensation dialog ..... 447
- Flatness Cal
  - Convergence ..... 415
  - Max Iterations ..... 415
  - Tolerance ..... 415
- Flatness calibration ..... 168
- Font Size ..... 511

- Format softtool ..... 252
  - FPGA update failure ..... 1145
  - Freq for Loss ..... 435, 450
  - Freq Step Size ..... 353
  - Frequency reference ..... 538
  - Frequency Resolution 1 mHz (R&S ZND-K19) ..... 202
  - Front panel ..... 28
  - Front panel keys ..... 36
  - Fullscreen mode ..... 516
- G**
- GET ..... 1157, 1160
  - Getting started ..... 13
  - Global settings ..... 69
  - Global Settings ..... 520
  - GPIB ..... 34
    - introduction ..... 559
  - GPIB Address ..... 539
  - GPIB bus interface ..... 1158
  - GPIB bus messages ..... 565
  - GPIB Explorer ..... 494, 560
  - GPIB Interface ..... 207
  - Graphic zoom ..... 54
  - Ground connector ..... 34
  - Group Delay ..... 257
    - Aperture Points ..... 257
  - GTL ..... 1160
- H**
- Handler I/O ..... 207, 1161
  - Handshake bus ..... 1158
  - Hardkey panel ..... 45
  - Hardware ..... 535
  - Hardware (connectors) ..... 1155
  - Hardware info ..... 535
  - Harmonic grid ..... 195
    - Automatic ..... 283
    - Set and keep ..... 282
  - Hide All Data ..... 273
  - Hide All Mem ..... 273
  - Hide All Other Traces ..... 266
  - Hide Sensitive Information ..... 510
  - HiSLIP ..... 559
  - Horiz. Line ..... 322
    - Response Value ..... 322
    - Show Horiz. Line ..... 322
- I**
- Ideal (cal kit) ..... 155
  - IEC/IEEE Bus Interface ..... 1158
  - IECWIN32 ..... 560
  - IEEE 370 ..... 202
  - IEEE 488 CH 1 ..... 1158
  - IEEE 488 CH 2 ..... 1158
  - IFC ..... 1159, 1160
  - Imag ..... 256
  - Imb12 (softkey) ..... 244
  - Imb21 (softkey) ..... 244
  - Imbal. CMRR tab ..... 243
  - Imbalance (softkey) ..... 244
  - Imbalance Differential dialog ..... 244
  - Imbalance measurement ..... 243
  - Imbalance parameters ..... 119
  - Impedance ..... 107
- Import
    - Cal Kit ..... 389
    - Sweep segments ..... 363
  - Import Complex Data dialog ..... 297
    - Import Data to New Mem ..... 298
  - Import Data to New Mem ..... 298
  - Impulse Response ..... 280
  - In-situ De-Embedding ..... 204
  - INFintiy ..... 569
  - Info dialog ..... 533
    - Cal Validation tab ..... 536
    - Hardware tab ..... 535
    - Options tab ..... 534
    - Selftest tab ..... 535, 536
    - Setup tab ..... 534
  - Info Table ..... 510
  - Instrument calibration ..... 62
  - Instrument hardware ..... 576
  - Instrument Messages ..... 541, 1161
  - Instrument security procedures ..... 14
  - Instrument setup ..... 21
  - Instrument-control commands ..... 566
  - Intended use ..... 16
  - Interface
    - functions (GPIB bus) ..... 1159
  - Interface Clear ..... 1159
  - Interface message ..... 565
  - Interface messages
    - GPIB ..... 1160
    - VXI-11 ..... 1157
  - Interfaces ..... 1155
  - Internal reference ..... 538
  - Inv Smith ..... 256
  - Inverted Smith chart ..... 100
  - IP Address ..... 539
  - IP address setting ..... 1151
  - ISD
    - Advanced settings ..... 461
  - IST flag ..... 580, 585
- K**
- K 21 (softkey) ..... 246
  - Keyboard ..... 25
  - Keyword (SCPI command) ..... 566
  - Kit Standards dialog ..... 405
    - Add standard ..... 407
    - Copy... standard ..... 407
    - Delete standard ..... 407
    - One Port Standards ..... 406
    - Read .s1p File... ..... 407
    - Read .s2p File... ..... 407
    - Two Port Standards ..... 406
    - View / Modify... standard ..... 407
  - Known devices
    - external power meters ..... 544
    - external switch matrices ..... 549
- L**
- LAN ..... 34
    - connection ..... 27
    - remote operation ..... 1150
  - LAN Detection
    - external power meters ..... 545
    - external switch matrices ..... 550
  - Language ..... 518

- Light Scheme ..... 514
  - Limit line ..... 122
    - files ..... 128
  - Limit Test ..... 304, 308
    - Add / Insert / Delete segment ..... 310
    - Clear Test ..... 307
    - Delete All segments ..... 310
    - Limit Check ..... 306
    - Limit Fail Beep ..... 307
    - Limit line from trace data ..... 311
    - Recall limit line ..... 310
    - Save limit line ..... 310
    - Segments ..... 309
    - Shift Lines ..... 308
    - Show Limit Line ..... 305
  - Limit Test tab
    - Controls ..... 305
  - Limits
    - Global Check ..... 307
    - TTL1 Pass ..... 307
    - TTL2 Pass ..... 307
  - Lin Freq ..... 355
  - Lin Mag ..... 255
  - Line Styles Scheme ..... 514
  - Lines softtool ..... 304
    - Circle Test tab ..... 317
    - Display Circle tab ..... 321
    - Horiz. Line tab ..... 322
    - Limit Test tab ..... 304
    - Ripple Test tab ..... 313
  - LLO ..... 1160
  - LOC ..... 1157
  - Log Errors ..... 542
  - Log Freq ..... 356
  - Log Mag ..... 255
  - Logical Port
    - Offset Embed Differential Match ..... 475
  - Loss
    - Active ..... 435
  - Loss (bandfilter) ..... 90
  - Loss at DC ..... 435, 450
  - Loss at Freq ..... 435, 450
  - Loss parameters
    - definition ..... 174
  - Low pass impulse ..... 194
  - Low Pass Settings dialog ..... 282
  - Low pass step ..... 194
  - Lower edge (bandfilter) ..... 90
  - Lower limit ..... 122
- M**
- Maintenance ..... 1169
  - Marker ..... 47, 84
    - Delta Mode ..... 325
    - Discrete ..... 327
    - Format ..... 326
    - Info ..... 328
    - Mkr 1 ... Mkr 10 ..... 325
    - Mode ..... 327
    - Name ..... 326
    - On ..... 324
    - Properties ..... 326
    - Props ..... 326
    - Ref Mkr -> Mkr ..... 328
    - Response ..... 324
    - Search ..... 323
      - set by ..... 58
      - Settings ..... 323
      - Stimulus ..... 324
      - Style ..... 327
  - Marker coupling ..... 88
  - Marker Format ..... 326
  - Marker Info ..... 328
  - Marker info field ..... 85
  - Marker Mode
    - Arbitrary ..... 327
    - Fixed ..... 327
    - Normal ..... 327
  - Marker Name ..... 326
  - Marker Search ..... 328
    - Max / Min ..... 329
    - Next Peak ..... 329
    - Peak Left / Peak Right ..... 330
    - Peak Type ..... 329, 330
    - Search Mode ..... 337
  - Marker search functions ..... 89
  - Marker softtool ..... 323
    - Bandfilter tab ..... 337
    - Info Field tab ..... 343
    - Marker Coupling tab ..... 343
    - Marker Props tab ..... 326
    - Marker Search tab ..... 328
    - Markers tab ..... 323
    - Multiple Peak tab ..... 333
    - Set by Marker tab ..... 341
    - Target Search tab ..... 335
  - Marker Style ..... 327
  - Markers
    - All Off ..... 324
    - Coupled Markers ..... 325, 344
    - Decimal Places ..... 328
    - Export ..... 328
    - Ref Mkr ..... 325
    - Max (softkey, trace scale) ..... 261
    - Max = Marker ..... 342
    - MAXimum ..... 569
  - Meas
    - Power Sensor ..... 247
    - S-Params ..... 222
  - Meas Delay ..... 354
  - Meas softtool ..... 221
    - Imbal. CMRR tab ..... 243
    - Power Sensor tab ..... 247
    - Ratios tab ..... 231
    - S-Params tab ..... 222
    - Stability tab ..... 246
    - Wave tab ..... 234
    - Y-Z-Params tab ..... 241
    - Y←Sij tab ..... 239
    - Z←Sij tab ..... 237
  - Measure Fixture ..... 448
  - Measurement examples ..... 60
  - Measurement receiver calibration ..... 169
  - Measurement results ..... 103
  - Measurements ..... 221
    - CMRR ..... 243
    - Converted admittances ..... 239
    - Converted impedances ..... 237
    - Differential imbalance ..... 244
    - Imbalance ..... 243
    - Port activation on demand ..... 221
    - Power (with external power meter) ..... 247
    - Ratios of wave quantities ..... 231



- S-parameters ..... 222
  - Stability factors  $K$ ,  $\mu_1$ ,  $\mu_2$  ..... 246
  - Wave quantities ..... 234
  - Y-parameters ..... 241
  - Z-parameters ..... 241
  - Mechanical Length ..... 444, 445
  - Mem Math tab
    - Controls ..... 274
  - Menu bar ..... 43
  - Menu Bar
    - Show/hide ..... 516
  - Menus ..... 44
  - Messages (system settings) ..... 524
    - Show Error Messages ..... 525
    - Show Info Messages ..... 525
    - Show Instrument Messages ..... 525
    - Show Warning Messages ..... 525
  - Min (softkey, trace scale) ..... 261
  - Min = Marker ..... 342
  - Minimize application ..... 27
  - MINimum ..... 569
  - Mixed mode parameters ..... 117
  - Mode conversion factor ..... 117
  - Mode tab
    - Driving Mode ..... 433
  - Modify Cal Power (dialog) ..... 416
  - Monitor ..... 25
  - MONITOR (DVI-D) ..... 34
  - More Ratios dialog ..... 232
  - More Wave Quantities dialog ..... 235
  - Mounting into a 19" rack ..... 22
  - Mouse ..... 26
  - Multiple Peak search ..... 333
    - Eval Range ..... 334
    - Max ..... 334
    - Min ..... 334
    - Tracking ..... 334
  - Multiple triggers
    - Source ..... 369
- N**
- NAN (not a number) ..... 569
  - Navigation keys ..... 32
  - Navigation tools ..... 40
  - NDAC ..... 1159
  - New (recall set) ..... 486
  - New Trace dialog ..... 267
  - NINF (negative infinity) ..... 569
  - Notch (time gate) ..... 285
  - NRFD ..... 1159
  - NTR ..... 580
  - NTRansition ..... 581, 583
  - Number of Points ..... 346, 353
  - Numerator ..... 233
  - Numeric Editor (dialog) ..... 52
  - Numeric Suffix (remote control) ..... 595
- O**
- Offset
    - Active ..... 435
  - Offset Embed
    - All Offsets Off ..... 436
    - All Offsets On ..... 436
    - Balanced ..... 439
    - Differential Match Embedding ..... 442
    - Fixture Compensation ..... 447
    - Ground Loop ..... 441
    - Impedance Renormalization ..... 441, 442
    - Loss ..... 435
    - Loss active ..... 435
    - Offset active ..... 435
    - Port Pairs ..... 467
    - Port Sets ..... 437
    - Reset Offsets ..... 435
    - Reset Offsets (and losses) ..... 436
    - Single Ended deembedding ..... 437
    - Single Ended embedding ..... 437
  - Offset Embed dock widget ..... 434
    - Balanced panel ..... 439
    - Calculation Flow ..... 434
    - Differential Match panel ..... 442
    - Ground Loop panel ..... 441
    - Impedance Renormalization panel ..... 441
    - Offset ..... 435
    - Overview ..... 434
    - Port Sets panel ..... 437
    - Single Ended panel ..... 437
  - Offset Embed softtool ..... 434
    - Balanced tab ..... 469
    - Delta-L tab ..... 477
    - Differential Match tab ..... 474
    - Ground Loop tab ..... 472
    - Offset tab ..... 443
    - One Way Loss tab ..... 449
    - Port Sets tab ..... 467
    - Single Ended tab ..... 451
  - Offset parameters ..... 173
    - application ..... 178
    - balanced ports ..... 179
    - definition ..... 173
  - Offset tab
    - Fixture Compensation dialog ..... 447
  - On-screen keyboard
    - analyzer ..... 53
    - Windows ..... 53
  - Open Recall ..... 486
  - Operating system ..... 1149
  - Operation complete ..... 585
  - OPERation register ..... 580, 586
  - Option
    - Z14 ..... 1161
    - R&S ZN-B14 ..... 207, 1161
    - R&S ZNC-B10 ..... 207
    - R&S ZND-B10 ..... 207
    - R&S ZND-B19 ..... 207
    - R&S ZND-K2 ..... 279, 284
    - R&S ZND-K3 (Distance to Fault) ..... 495
    - R&S ZND-K7 ..... 207
  - Option R&S ZND-K2
    - Time domain analysis ..... 193
  - Option R&S ZND-K3
    - Distance-to-fault measurements ..... 200
  - Options ..... 534
    - R&S ZND-K210 ..... 202
    - R&S ZND-K220 ..... 204
    - R&S ZND-K230 ..... 204
    - R&S ZND-K231 ..... 204
    - R&S ZVAB-B44 ..... 542
  - Options (overview) ..... 191
  - Options info ..... 534
  - Output unit ..... 576



- Overlapped command execution ..... 576
- P**
- Packing ..... 1170
- Parallel Poll ..... 591
- Parameter (remote control) ..... 595
- Partial measurement ..... 73
- Password ..... 1150
  - Service Function ..... 538
- Permittivity ..... 445
- Persistent settings ..... 69
- Phase ..... 253
- Polar ..... 254
- Polar diagram ..... 97
- Port
  - Gender ..... 388
  - Offset ..... 444
- Port Config
  - Port Settings ..... 431
- Port Config tab ..... 430
- Port Power Offset ..... 417
- Port Settings dialog ..... 431
- Ports
  - Calibration ..... 378, 386
- Power ..... 347
- Power (system settings) ..... 528
- Power Bw Avg softtool ..... 349
  - Average tab ..... 350
  - Bandwidth tab ..... 349
  - Power tab ..... 349
- Power Cal dialog
  - Meas. Receiver mode ..... 396
  - Power mode ..... 395
  - Source Flatness mode ..... 397
- Power Cal dialog (Meas. Receiver) ..... 396
  - Port overview ..... 396
  - Start Cal Sweep ..... 397
- Power Cal dialog (Power) ..... 395
  - Start Cal Sweep ..... 395
- Power Cal dialog (Source Flatness) ..... 397
  - Start Cal Sweep ..... 398
- Power Cal wizard ..... 392
  - Calibration sweep diagram ..... 393
  - Screen elements ..... 393
- Power calibration ..... 167
  - measurement receiver ..... 169
  - Power Meter ..... 416
  - Procedure ..... 374
  - reference receiver ..... 168
  - Settings ..... 414
  - source ..... 168
  - Switch Off Other Sources ..... 415
- Power Meter
  - Auto Zero ..... 416
  - Power calibration ..... 416
- Power meter (external) ..... 208
- Power Meter Transmission Coefficients dialog ..... 418
  - Two Port Configuration dialog ..... 419
- Power on and off ..... 23
- Power Sensor (menu) ..... 247
- Power Sensor tab ..... 247
- Power sweep ..... 357
- Power tab ..... 346, 349
- PPC ..... 1160
- PPE ..... 580, 585
- PPU ..... 1160
- Preparing for use ..... 28
- Preset ..... 592
- Preset Configuration ..... 520
- Preset Scope ..... 520
- Presets (system settings) ..... 519
- Print ..... 490
- Printer ..... 26
- Printing data ..... 66
- Program example ..... 1135
  - calibration ..... 1135
- Programming examples ..... 1110
- PTR ..... 582
- PTRansition ..... 581
- Public folder ..... 841
- Putting into operation ..... 20
- Q**
- Quality factor (bandfilter) ..... 90
- Query ..... 565, 566
- QUEStionable register ..... 580, 586
  - Summary bit ..... 584
- QUEStionable:INTegrity register ..... 587
- QUEStionable:LIMit register ..... 586
- R**
- R&S ZN-B14 ..... 207
- R&S ZN-B14 (Handler I/O) ..... 1161
- R&S ZNC-B10 ..... 207
- R&S ZND-B10 ..... 207
- R&S ZND-B19 ..... 207
- R&S ZND-K2 ..... 279, 284
- R&S ZND-K3 (Distance to Fault) ..... 495
- R&S ZND-K7 ..... 207
- R&S ZND-K19 (Frequency Resolution 1 mHz) ..... 202
- R&S ZVAB-B44 (option) ..... 542
- R&S ZVR compatible commands ..... 1087
- Ratio ..... 113
- Ratios tab ..... 231
- Read-only folder ..... 841
- Real ..... 256
- Rear panel ..... 34
  - USER PORT ..... 1156
- Recall Ripple Test ..... 317
- Recall set ..... 70
- Recall Set functions
  - Basic ..... 485
  - Recall switch matrix configuration ..... 487
- Recent Files ..... 487
- Reduced Through calibration ..... 151
- Ref Mkr -> Mkr ..... 328
- REF OUT / IN ..... 34
- Ref Pos ..... 261
- Ref Val = Marker ..... 342
- Ref Value ..... 261
- Reference impedance ..... 105
- Reference position ..... 57
- Reference Receiver Cal Power ..... 418
- Reference value ..... 57
- Reflection measurement (example) ..... 67
- Release notes ..... 14, 17
- REM ..... 1157
- Remote control ..... 559, 1119
  - activation ..... 562
  - basic concepts ..... 572
  - introduction ..... 559

- Remote Control
    - Codec ..... 518
    - combine with manual control ..... 565
  - Remote desktop ..... 1153
  - Remote Language ..... 540
  - Remote Preset Configuration ..... 520
  - Remote Settings ..... 539
    - Advanced ..... 541
    - Define \*IDN + \*OPT... ..... 540
    - GPIB Address ..... 539
    - Instrument Messages ..... 541
    - IP Address ..... 539
    - Remote Language ..... 540
  - REN ..... 1159
  - Renormalization (of port impedances) ..... 105
  - Renormalization theory
    - Power waves ..... 230
    - Travelling waves ..... 230
  - Reset values
    - Status reporting system ..... 592
  - Resolution Enh(ancement) ..... 281
  - Response (to queries) ..... 566
  - Restart Manager dialog ..... 373
    - Sweep Active Channel ..... 374
    - Sweep All Channels ..... 373
  - Restart Sweep ..... 371
  - Restart Sweep on Std. Meas. .... 392
  - Revision ..... 17
  - RF Off All Channels ..... 347
  - Ripple limit ..... 122
    - files ..... 129
  - Ripple Test ..... 313, 315
    - Clear Test ..... 315
    - Ranges ..... 316
    - Ripple Check ..... 314
    - Ripple Fail Beep ..... 315
    - Show Results All Traces ..... 315
    - Show Ripple Limits ..... 313
  - Rotary knob ..... 32
- S**
- S-parameter ..... 104
    - multiport ..... 105
  - S-parameter buttons ..... 223
  - S-Parameter selector ..... 222
  - S-Parameter Wizard ..... 60, 224
  - S-Params tab ..... 222
  - Safety information ..... 16
  - Safety instructions ..... 14
  - Same Color all Markers ..... 513
  - Save (recall set) ..... 487
  - Save Ripple Test ..... 317
  - Saving data ..... 66
  - Scalar power calibration ..... 167
  - Scale
    - Scale Coupling ..... 262
    - Scale Coupling tab ..... 262
    - Scale softtool ..... 259
      - Scale Coupling tab ..... 262
      - Scale Values tab ..... 259
      - Zoom tab ..... 262
    - Scale Values tab ..... 259
  - Scale/Div ..... 260
  - Scaling diagrams ..... 54
  - Scan Instruments
    - external power meters ..... 544, 550
  - SCPI command structure ..... 566
  - SCPI commands ..... 566
  - SCPI status register ..... 581
    - event status register ..... 585
    - IST flag ..... 585
    - parallel poll enable register ..... 585
    - service request enable register ..... 584
    - status byte ..... 584
    - STATus:OPERation register ..... 586
    - STATus:QUESTionable register ..... 586
    - STATus:QUESTionable:INTegrity ..... 587
    - STATus:QUESTionable:LIMit ..... 586
    - Structure ..... 580
  - Screen elements ..... 81
  - Screen Keyboard ..... 494
  - Screen saver ..... 29
  - SDC ..... 1160
  - Search functions ..... 89
  - Search Path for additional Cal Kits and Connector Types ..... 522
  - Search Range dialog ..... 331
    - Range Limit Lines On ..... 332
    - Search Range ..... 331
    - Select Marker ..... 331
  - Security procedures ..... 14
  - Seg X-Axis ..... 359
  - Segmented sweep ..... 356
    - Define Segments dialog ..... 360
    - Export segments ..... 363
    - Import segments ..... 363
  - Select Parameter dialog ..... 302
  - Select Ports dialog ..... 303
  - Selftest ..... 535
  - Selftest info ..... 535, 536
  - Sequential command execution ..... 576
  - Serial poll ..... 591
  - Service Function ..... 537, 538
    - Password ..... 538
  - Service Function dialog ..... 537
  - Service manual ..... 13
  - Service request ..... 590
  - Service Request Enable ..... 580, 584
  - Set by Marker ..... 341
    - Center ..... 342
    - Max ..... 342
    - Min ..... 342
    - Ref Value ..... 342
    - Span ..... 342
    - Start ..... 342
    - Stop ..... 342
    - Zero Delay at Marker ..... 343
  - Setup
    - Device LAN Configuration ..... 551
    - External devices ..... 541
    - External Devices ..... 547
    - External Matrices ..... 548
    - External Power Meter Config ..... 546
    - External Power Meters ..... 543
    - Reference ..... 538
    - Switch Matrix RF Connections ..... 552
  - Setup info ..... 534
  - Setup information ..... 534
  - Setup keys ..... 30
  - Setup softtool ..... 517
    - External Devices tab ..... 541
    - External Ports tab ..... 547
    - Freq. Ref. tab ..... 538

|                                   |                |                                           |          |
|-----------------------------------|----------------|-------------------------------------------|----------|
| Remote Settings tab .....         | 539            | Status registers .....                    | 580      |
| Setup tab .....                   | 518            | Status reporting system                   |          |
| SFD                               |                | common commands .....                     | 594, 596 |
| Advanced settings .....           | 465            | Error queue .....                         | 592      |
| Shape (time gate) .....           | 285            | Parallel poll .....                       | 591      |
| Shift JIS .....                   | 518            | Queries .....                             | 591      |
| Shift trace                       |                | Reset values .....                        | 592      |
| response .....                    | 294            | Serial poll .....                         | 591      |
| stimulus .....                    | 294            | Service request .....                     | 590      |
| Shift Trace .....                 | 294            | STB .....                                 | 580, 584 |
| Show <Trace Name> .....           | 266            | Step Size (dialog) .....                  | 53       |
| Show All Data .....               | 273            | STIMULUS .....                            | 30       |
| Show All Mem .....                | 273            | Stimulus softtool .....                   | 345      |
| Show All Traces .....             | 266            | Power tab .....                           | 346      |
| Show as .....                     | 236            | Stimulus tab .....                        | 345      |
| Show Cal Kit Label .....          | 521            | Time Domain X-Axis tab .....              | 347      |
| Show Limit Fail Symbols .....     | 512            | Stimulus tab .....                        | 345      |
| Show Point List .....             | 362            | Center Frequency .....                    | 346      |
| Show/Hide data trace .....        | 272            | CW Frequency .....                        | 346      |
| Show/Hide memory trace .....      | 272            | Number of Points .....                    | 346      |
| Side lobe level                   |                | Power .....                               | 347      |
| Frequency window .....            | 281            | Span Frequency .....                      | 346      |
| Side Lobe Level (time gate) ..... | 285            | Start Frequency .....                     | 346      |
| Single sweep .....                | 370            | Stop Frequency .....                      | 346      |
| Single sweep mode                 |                | STOP .....                                | 76       |
| Sweeps (# of) .....               | 371            | Stop = Marker .....                       | 342      |
| Single-ended mode .....           | 115, 117       | Stop Frequency .....                      | 346      |
| Sliding Match .....               | 156            | Stop Power .....                          | 347      |
| Smart Fixture De-Embedding .....  | 204            | Storing .....                             | 1170     |
| Smith .....                       | 254            | String .....                              | 569      |
| Smith chart .....                 | 98             | Support .....                             | 1146     |
| Smoothing .....                   | 293            | Sweep                                     |          |
| Aperture .....                    | 293            | Sweep Params .....                        | 352      |
| Softtool panel                    |                | Sweep Active Channel .....                | 374      |
| Minimize/maximize .....           | 517            | Sweep All Channels .....                  | 373      |
| Softtools .....                   | 42             | Sweep Control                             |          |
| Software Option Info .....        | 535            | Restart Manager dialog .....              | 373      |
| Source                            |                | Sweep Control tab .....                   | 370      |
| Calibration .....                 | 387            | Sweep History .....                       | 1133     |
| Source Port .....                 | 233            | Sweep mode                                |          |
| Source power calibration .....    | 168            | Continuous .....                          | 370      |
| SPAN .....                        | 76             | Single .....                              | 370      |
| Span = Marker .....               | 342            | Sweep range selection .....               | 61       |
| Span Frequency .....              | 346            | Sweep range setting .....                 | 56       |
| SPD .....                         | 1160           | Sweep settings .....                      | 352      |
| SPE .....                         | 1160           | Sweep softtool                            |          |
| Split All .....                   | 506            | Sweep Control tab .....                   | 370      |
| Split diagrams .....              | 506            | Sweep Type tab .....                      | 355      |
| Dual Split .....                  | 507            | Trigger tab .....                         | 365      |
| Quad Split .....                  | 507            | Sweep Time .....                          | 354      |
| Triple Split .....                | 507            | Sweep Type                                |          |
| Split Type .....                  | 508            | CW Mode .....                             | 358      |
| SRE .....                         | 580, 584       | Lin Freq .....                            | 355      |
| SRQ .....                         | 580, 590, 1159 | Log Freq .....                            | 356      |
| Stability (softkey) .....         | 246            | Power .....                               | 357      |
| Stability factors .....           | 120            | Segmented .....                           | 356      |
| Stability tab .....               | 246            | Time .....                                | 359      |
| Standby and ready state .....     | 24             | Sweep Type tab .....                      | 355      |
| Standby key .....                 | 32             | Sweeps (# of) .....                       | 371      |
| START .....                       | 76             | Switch Matrices                           |          |
| Start = Marker .....              | 342            | Add Switch Matrix (dialog) .....          | 553      |
| Start Frequency .....             | 346            | Delete Switch Matrix (dialog) .....       | 554      |
| Start Power .....                 | 347            | Switch Matrix RF Connections dialog ..... | 552      |
| Startup and shutdown .....        | 23             | SWR .....                                 | 254      |
| Status bar .....                  | 45             | Symmetric Params .....                    | 300      |
| Status Bar                        |                | Syntax elements (SCPI, overview) .....    | 569      |
| Show/Hide .....                   | 516            | SYSTEM .....                              | 31       |

|                                 |            |                                          |      |
|---------------------------------|------------|------------------------------------------|------|
| System Config dialog .....      | 519        | Trace Config softtool .....              | 264  |
| Advanced tab .....              | 526        | All Mem All Data tab .....               | 272  |
| Calibration tab .....           | 521        | Distance to Fault tab .....              | 495  |
| Channel Bits tab .....          | 525        | Hold .....                               | 292  |
| Messages tab .....              | 524        | Mem tab .....                            | 269  |
| Power tab .....                 | 528        | Shift Trace .....                        | 292  |
| Presets tab .....               | 519        | Smooth Shift Hold tab .....              | 292  |
| User Interface tab .....        | 522        | Smoothing .....                          | 292  |
| System settings .....           | 517        | Time Domain tab .....                    | 279  |
| <b>T</b>                        |            | Time Gate tab .....                      | 284  |
| Target Search .....             | 335, 337   | Trace Data tab .....                     | 296  |
| Search Left .....               | 337        | Trace Statistics tab .....               | 286  |
| Target Format .....             | 336        | Traces tab .....                         | 264  |
| Target Value .....              | 336        | Trace Data .....                         | 492  |
| Task bar                        |            | Export .....                             | 296  |
| Show/hide .....                 | 516        | Import .....                             | 296  |
| Test port .....                 | 33         | Import Complex Data .....                | 297  |
| Text parameter .....            | 569        | Trace Data import                        |      |
| Time Center .....               | 348        | Auto Distribute traces .....             | 302  |
| Time Domain .....               | 280        | Deselect All traces .....                | 302  |
| Time domain analysis .....      | 279, 284   | Select All traces .....                  | 302  |
| Option R&S ZND-K2 .....         | 193        | Select Parameter .....                   | 302  |
| Time Domain Transform .....     | 193        | Trace files .....                        | 129  |
| Time domain transformation      |            | Trace format .....                       | 252  |
| Impulse Response .....          | 280        | dB Mag .....                             | 253  |
| Type .....                      | 280        | Delay .....                              | 257  |
| Time Domain X-Axis tab .....    | 347        | Imag .....                               | 256  |
| Time Gate .....                 | 284        | Inv Smith .....                          | 256  |
| Bandpass .....                  | 285        | Lin Mag .....                            | 255  |
| Notch .....                     | 285        | Log Mag .....                            | 255  |
| Shape .....                     | 285        | Phase .....                              | 253  |
| Show Range Lines .....          | 285        | Polar .....                              | 254  |
| Side Lobe Level .....           | 285        | Real .....                               | 256  |
| Time Span .....                 | 348        | Smith .....                              | 254  |
| Time Start .....                | 348        | SWR .....                                | 254  |
| Time Stop .....                 | 348        | Unwr Phase .....                         | 255  |
| Time sweep .....                | 359        | Trace formats .....                      | 95   |
| Time vs. Distance .....         | 349        | Trace Info .....                         | 510  |
| Title (diagram) .....           | 82         | Trace list .....                         | 83   |
| Title bar .....                 | 41         | Trace Manager dialog .....               | 267  |
| Show/hide .....                 | 516        | Add .....                                | 269  |
| Title Bar Task Bar .....        | 494        | Couple All Channels .....                | 269  |
| Tool 3 ... Tool 8 .....         | 494        | Couple All Scales .....                  | 269  |
| Tool Bar                        |            | Decouple All Channels .....              | 269  |
| Show/hide .....                 | 516        | Decouple All Scales .....                | 269  |
| Toolbar .....                   | 41         | Delete .....                             | 269  |
| Touchscreen .....               | 29         | Trace Math .....                         | 274  |
| Configuration .....             | 517        | Data - <Mem> .....                       | 275  |
| Enabled .....                   | 517        | Data / <Mem> .....                       | 275  |
| Lock Diagrams .....             | 517        | User Defined .....                       | 275  |
| Lock Screen .....               | 517        | Trace Statistics .....                   | 286  |
| Touchstone (*.s<n>p) file ..... | 130        | Compr. Point .....                       | 289  |
| Trace .....                     | 47, 70, 82 | Compr. Val. .....                        | 289  |
| Dfit Marker Frmt .....          | 259        | Evaluation Range .....                   | 291  |
| programming examples .....      | 1113       | Evaluation Range Limit Lines On .....    | 292  |
| TRACE .....                     | 30         | Flatness/Gain/Slope .....                | 288  |
| Trace Colors per Diagram .....  | 513        | Format .....                             | 287  |
| Trace Config                    |            | Mean/Std Dev/RMS .....                   | 286  |
| Hold .....                      | 294        | Min/Max/Peak-Peak .....                  | 286  |
| Max Hold .....                  | 294        | Phase/EI Length .....                    | 288  |
| Min Hold .....                  | 294        | Tracking                                 |      |
| Shift Trace .....               | 294        | marker search, target search .....       | 330  |
| Smoothing .....                 | 293        | Transmission measurement (example) ..... | 60   |
|                                 |            | Trigger                                  |      |
|                                 |            | Delay .....                              | 368  |
|                                 |            | EXT TRIG IN .....                        | 1157 |
|                                 |            | EXT TRIG OUT .....                       | 1157 |

- External ..... 366
  - FreeRun ..... 366
  - Manual ..... 366
  - Manual Trigger ..... 367
  - Multiple Triggers ..... 366
  - Sequence ..... 367
  - Signal Type ..... 368
  - Source ..... 366
  - Trigger Manager dialog ..... 368
    - Source ..... 369
  - Trigger tab ..... 365
    - Controls ..... 366
  - Troubleshooting ..... 1143
  - TTL Pass ..... 528
  - Two Port Configuration dialog ..... 419
    - Power loss list ..... 420
    - Transm. Coefficients ..... 420
  - Typical (cal kit) ..... 155
- U**
- Unbalance-balance conversion ..... 115
  - Universal command ..... 565, 1160
  - Universal Interface ..... 207, 1161
  - Unwr Phase ..... 255
  - UP ..... 569
  - Upper edge (bandfilter) ..... 90
  - Upper limit ..... 122
  - Upper/lower case (remote control) ..... 595
  - USB ..... 33
  - USB-to-GPIB Adapter ..... 208
  - USB-to-IEC/IEEE adapter ..... 542
  - USB-to-IEC/IEEE Adapter ..... 208
  - Use Cal tab
    - All Power Cals Off ..... 422
    - All Power Cals On ..... 422
    - Controls ..... 421
    - Recall Last Cal Set ..... 422
    - User Cal Active ..... 421
  - Use Trc Color for Limit Lines ..... 513
  - User Def Math dialog ..... 275
    - Expression builder ..... 276
    - Result is Wave Quantity ..... 278
  - User Interface (system settings) ..... 522
    - Conductance in Embedding Networks ..... 523
    - Decimal Places ..... 524
    - Reset Colors ..... 524
    - Reset Decimal Places ..... 524
    - Reset Dialogs ..... 524
    - Reset Units Prefix ..... 524
    - Show Sweep Symbols ..... 523
    - Sounds ..... 522
    - Transparent Info Fields ..... 523
    - Units Prefix ..... 524
    - Use Default Tab for Hardkey ..... 523
  - USER PORT ..... 34, 1156
    - TTL Pass output ..... 528
  - UTF-8 ..... 518
- V**
- Velocity Factor ..... 445
  - View / Modify Cal Kit Standards dialog ..... 407, 408
    - Characteristic impedance Z0 ..... 408
    - Delay ..... 408
    - Electrical Length ..... 408
    - Load parameters ..... 408
  - Loss ..... 408
    - Offset Loss ..... 408
    - Offset parameters ..... 408
  - Virtual differential mode ..... 115
  - Virus protection ..... 1150
  - VISA ..... 559
  - VNA Port Assignment ..... 412
  - VXI-11 ..... 559
- W**
- Wave quantities
    - Source port ..... 236
  - Wave quantity ..... 112, 236
  - Wave tab ..... 234
  - White papers ..... 14
  - Window mode ..... 516
  - Windows ..... 1149
  - Windows Explorer ..... 495
  - Wizard ..... 60
- Y**
- Y <- (softkey) ..... 240
  - Y <- S-Parameters
    - Model ..... 240
  - Y-parameter ..... 111
  - Y-parameters ..... 241
  - Y-Z-Params tab ..... 241
  - Y/Z-Parameter (softkey) ..... 242
  - Y←Sij tab ..... 239
  - Y<-S11 (softkey) ..... 240
  - Y<-S12 (softkey) ..... 240
  - Y<-S21 (softkey) ..... 240
  - Y<-S22 (softkey) ..... 240
  - Y11 (softkey) ..... 242
  - Y12 (softkey) ..... 242
  - Y21 (softkey) ..... 242
  - Y22 (softkey) ..... 242
- Z**
- Z ← (softkey) ..... 238
  - Z <- S-Parameters
    - Model ..... 238
  - Z-parameter ..... 110
  - Z-parameters ..... 241
  - Z←S11 (softkey) ..... 238
  - Z←S12 (softkey) ..... 238
  - Z←S21 (softkey) ..... 238
  - Z←S22 (softkey) ..... 238
  - Z←Sij tab ..... 237
  - Z11 (softkey) ..... 242
  - Z12 (softkey) ..... 242
  - Z21 (softkey) ..... 242
  - Z22 (softkey) ..... 242
  - Zero Delay at Marker ..... 343
  - Zoom ..... 54
    - Max ..... 264
    - Min ..... 264
    - Overview On ..... 264
    - Start ..... 264
    - Stop ..... 264
  - Zoom Reset ..... 264
  - Zoom Select ..... 263
  - Zoom tab ..... 262