



MTS Landmark™ 100 Hz Elastomer Test System

Perform dynamic characterization of elastomeric components and materials

The MTS Landmark 100 Hz Elastomer Test System is configured specifically for characterizing the dynamic properties of elastomeric materials and components.

The compact tabletop system is optimized for frequencies up to 100 Hz and available with maximum force capacities of 15 kN or 25 kN.

It combines the latest in MTS servohydraulic load frame technology, versatile FlexTest® controls, a variety of elastomer test application software, and a full selection of grips, fixtures and test environments to meet your specific elastomer testing requirements.

MTS Performance

The MTS Landmark 100 Hz Elastomer Test System combines all the high-performance attributes that MTS test systems are renowned for into a new, highly stiff, ergonomic and easy-to-maintain load frame.

PROVEN SERVOHYDRAULIC TECHNOLOGY

MTS Landmark Elastomer Test Systems integrate the latest in MTS servohydraulic technology, including:

- » MTS Model 370.02 Load Frames that feature extremely stiff and lightweight crossheads with high natural frequencies, and precision-machined columns for consistently tight alignment.
- » Fatigue-rated MTS actuators, which employ best-in-class MTS load cells, low-friction Annular Step Bearings, and coaxially mounted Linear Variable Differential Transformers (LVDT).

be certain.

- » Trouble-free SilentFlo™ hydraulic power units that are quiet enough to be located directly in the laboratory.
- » A smooth-ramping hydraulic service manifold (57 lpm) that features five-port servovalves; proportional, local hydraulic station control; close-coupled accumulators; and Off-Low-High pressure control.

FLEXTEST CONTROL

Versatile FlexTest SE, FT40 & FT60 digital controllers provide the flexibility needed to address a full spectrum of testing needs and adapt readily to evolving standards or requirements. Scalable and easy-to-use, FlexTest controllers provide the high-speed closed-loop control, data acquisition, function generation and transducer conditioning required for reliable multichannel, multistation testing.

MTS ELASTOMER TEST APPLICATION SOFTWARE

The MTS Landmark 100 Hz Elastomer Test System accommodates an array of application software packages to help you automate almost every standard or custom elastomer test procedure. Designed specifically for characterizing the dynamic properties and fatigue behavior of elastomeric materials and components, these tightly integrated packages take advantage of the advanced control, calibration, and characterization capabilities inherent in the MTS Landmark System to deliver highly accurate and repeatable test results. Packages include:

- » Model 793.17 – Dynamic Property Monitor
- » Model 793.30 – Elastomer Express™
- » Model 793.31 – Dynamic Characterization
- » Model 793.32 – Advanced Dynamic Characterization
- » Model 793.33 – Static Deflection
- » Model 793.35 – Elastomer QC
- » Model 793.37 – Resonance Search

Innovative Cylinder-Centric Design

The MTS Landmark 100 Hz Elastomer Test System employs a cylinder-centric load frame design that delivers superior stiffness, alignment and ease-of-maintenance, resulting in more efficient operation and minimal downtime over the life of the system.

INTEGRATED ACTUATOR BEAM

The cylinder-centric design integrates fatigue-rated MTS actuators directly into the crossbeam to comprise an Integrated Actuator Beam. This minimizes the number of required joints, yielding a frame that exhibits high axial and lateral stiffness and superior reliability. Easy access to both sides of the cylinder facilitates quick and efficient servicing.

PILOTED END-CAPS

Precision-machined connections between the actuator cylinder and end caps guarantee extremely tight and consistent alignment over the life of the system, adding to the overall reliability of the actuator and eliminating the need for realignment after periodic maintenance.

DIRECT ACTUATOR PORTING

Direct mounting and porting of servovalves on the Integrated Actuator Beam minimize pressure loss for more efficient delivery of hydraulic power. A single-plane interface provides for high-integrity connections to a new family of high-performance hydraulic service manifolds.

Leading-Edge Ergonomics

The MTS Landmark 100 Hz Elastomer Test System features a user-friendly testing environment that emphasizes operator well-being and simplifies test setup and operation. This enables operators to safely and reliably perform more tests with fewer damaged or misaligned specimens.

INTUITIVE, CENTRALIZED CONTROLS

MTS Landmark controls are designed to keep operators focused on the test space while setting up tests. Conveniently located to eliminate any need for awkward bending and long reaching, they feature easy-to-turn handles and clear, universally understood labeling.

ENHANCED SAFETY FEATURES

MTS Landmark Systems provide a standard level of safety that exceeds the guidelines of CE and other organizations:

- » Automated Crosshead Positioning provides tight control of crosshead lifting and lowering to ensure safe operation and reduce test setup time.
- » An Actuator Velocity Limiting Circuit restricts the actuator's speed as it moves into test position, preventing unexpected motion that could injure operators.
- » Positive Specimen Gripping for both the upper and lower grips ensures that specimens are attached securely and won't slip during testing.

HIGHLY EFFICIENT WORKSPACE

MTS Landmark Systems set a new standard for workspace accessibility and convenience:

- » The Model 370.02 load frame stand features an integrated T-slot table with channels to contain spilled fluids.
- » The compact system handset features a clear test status display, precision controls for fine actuator positioning and an ergonomic design for both right- and left-handed operators.

Model 370.02 Load Frame Features

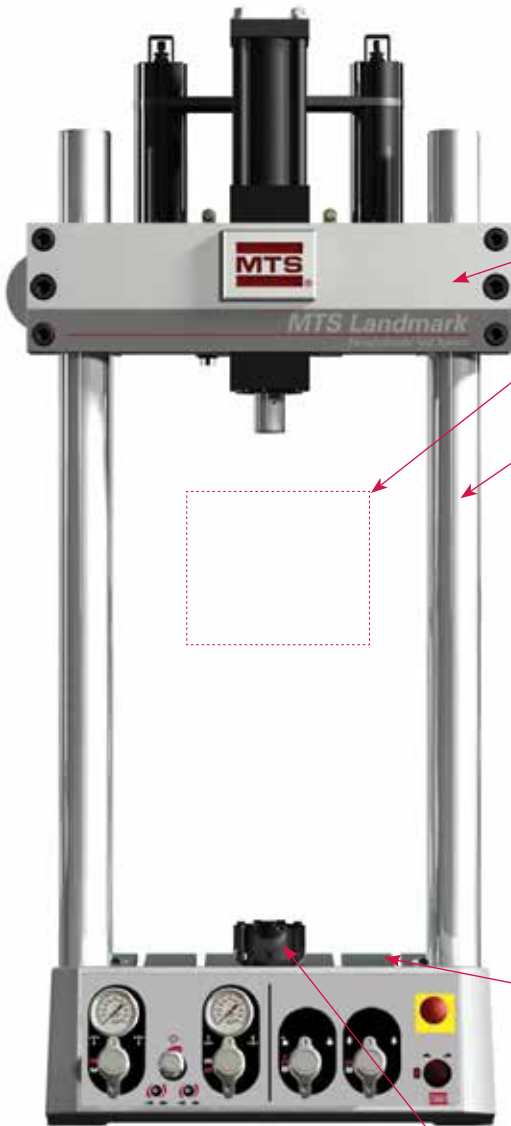

**Extremely Stiff,
Lightweight Crosshead**

MTS Accessories

- » Grips, fixtures and test environments

Precision-Machined Columns

Integrated Actuator Beam

- » Fully fatigue-rated
- » Direct actuator porting
- » Low-friction annular step bearings
- » Coaxially mounted linear variable differential transformers (LVDTs)
- » Piloted end-caps

**Smooth-Ramping Hydraulic
Service Manifolds**

- » Optional local filter
- » Protective guard
- » One 5-port servovalve
- » Actuator velocity limiting circuit

Integrated T-Slot Base

Automated Crosshead Positioning

- » Double-acting cylinders
- » Optional powered crosshead locks
- » Conveniently positioned system controls

Model 661 Load Cell

- » High output, fully fatigue-rated
- » Noise-reducing wiring
- » Temperature compensation
- » Low hysteresis and long-term stability
- » Accommodates all MTS grips, fixtures and platens

**Pneumatic/Elastomeric
Vibration Isolation Mounts**

Compact, Stable Footprint

OTHER AVAILABLE OPTIONS

- » Test area enclosure
- » Hydraulic crosshead positioning
- » Hydraulic crosshead locks
- » Actuator anti-rotation
- » Column stiffening tie bar
- » Alignment fixture
- » FlexTest handset & holder
- » Integrated grip controls
- » Load frame cart or stand



Load Frame Specifications ₁	Diagram Detail	Units	Model 370.02 100 Hz Elastomer
Force capacity (rated dynamic force)		kN (kip)	25 (5.5)
Available actuator ratings ₁		kN (kip)	15, 25 (3.3, 5.5)
Available dynamic stroke ₁		mm (in)	100, 150 (4, 6)
Min vertical test space - standard height ₂	A	mm (in)	144 (5.7)
Max vertical test space - standard height ₃	A	mm (in)	827 (32.6)
Min vertical test space - extended height ₂	A	mm (in)	398 (15.7)
Max vertical test space - extended height ₃	A	mm (in)	1335 (52.6)
Working height ₄	B	mm (in)	230 ₈ (9.1)
Column spacing	C	mm (in)	460 (18.1)
Column diameter (test space width)	D	mm (in)	76.2 (3.00)
Base width	E	mm (in)	622 (24.5)
Base depth	F	mm (in)	577 (22.7)
Diagonal clearance - standard height ₅	G	mm (in)	1750 ₈ (68.9)
Diagonal clearance - extended height ₅	G	mm (in)	2250 ₈ (88.6)
Overall height - standard height ₆	H	mm (in)	1989 ₈ (78.3)
Overall height - extended height ₆	H	mm (in)	2624 ₈ (103.3)
Stiffness ₇		N•m (lb/in)	345 x 10 ⁶ (1.95 x 10 ⁶)
Weight		kg (lb)	286 (630)

- All load frame specifications listed in this chart are based upon the actuator ratings and dynamic stroke values indicated by bold text.
- Min Vertical Test Space:** Span between force transducer and piston rod face when fully retracted at beginning of the dynamic stroke; crosshead down, no alignment fixture.
- Max Vertical Test Space:** Span between force transducer and piston rod face when fully retracted at beginning of the dynamic stroke; crosshead up, no alignment fixture.
- Working Height:** Floor to top of work surface; includes standard FabCell isolation.
- Diagonal Clearance:** Hose height to tip of foot with FabCell; crosshead down.
- Overall Height:** From floor, including standard FabCell isolation, to top of the hoses or highest point on actuator; crosshead fully raised.
- Measured at crosshead height of 600 mm (23.6 in).
- For load frames with optional pneumatic /elastomeric vibration isolation mounts, add 37 mm (1.44 in) to dimensions B, G, and H.



MTS Systems
14000 Technology Drive
Eden Prairie, MN 55344-2290 USA
Telephone: 1-952-937-4000
Toll Free: 1-800-328-2255
E-mail: info@mts.com
www.mts.com
ISO 9001 Certified QMS

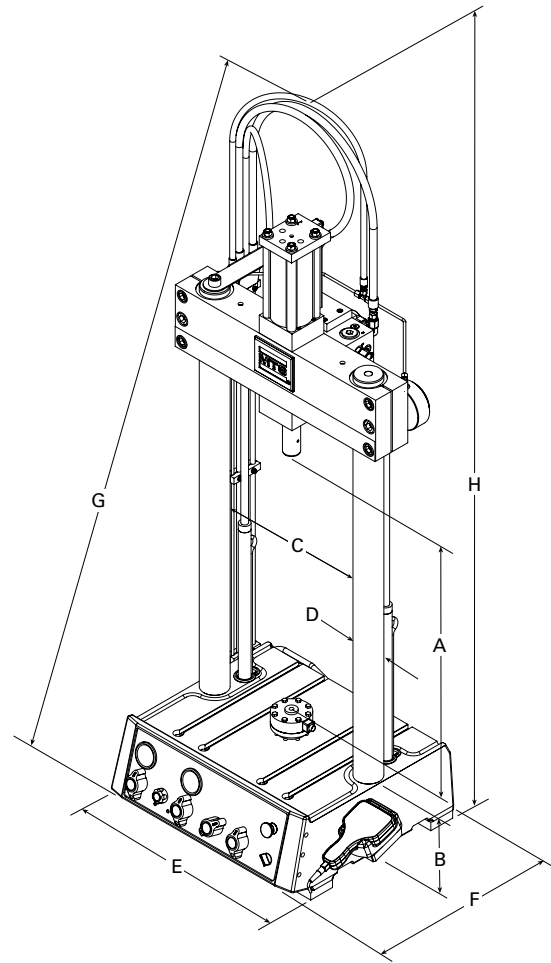

Streamlined System Procurement

The MTS Landmark 100 Hz Elastomer Test System features a straightforward system configuration methodology that allows you to quickly specify the mix of performance factors, standard available options, and MTS testing accessories appropriate for your particular test program and budget.

Unparalleled MTS Service & Support

MTS fields the most experienced service, support and consulting staff of any testing solution provider. This global team offers complete lifecycle management services to maximize the return on your MTS Landmark investment and help you meet your exact test requirements quickly.

To Learn More

Contact your local MTS sales engineer today to learn how the configurable, high-performing MTS Landmark 100 Hz Elastomer Test System can meet and exceed your elastomeric material and component test requirements—now and well into the future.

Specifications subject to change without notice.

MTS and RPC are registered trademarks and Remote Parameter Control is a trademark of MTS Systems within the United States. These trademarks may be protected in other countries. RTM No. 211177.

©2021 MTS Systems
100-199-127a Landmark100 • Printed in U.S.A. • 09/21