



www.regatron.com

Linear Post-Processing Unit

Model TC.LIN.SER



Operating instructions V1.07b

Regatron AG
Kirchstrasse 11
CH-9400 Rorschach
Tel +41 71 846 67 44
Fax +41 71 846 67 77
www.regatron.com
tc.support@regatron.ch

Distributor sticker

© 2009-2011 Regatron AG

This document is protected by copyright.

All rights, including translation, re-printing and duplication of this manual or parts of it, reserved. No part of this document is allowed to be reproduced or processed using electronic systems, copied or distributed in any form (by photocopying, microfilming or any other process), also not for educational purposes, without the written approval of Regatron AG.

This information in this documentation corresponds to the development situation at the time of going to print and is therefore not of a binding nature. Regatron AG reserves the right to make changes at any time for the purpose of technical progress or product improvement, without stating the reasons. In general we refer to the applicable issue of our "Terms of delivery".

Version overview	
Operating instructions	Version V1.07bb 2011-12-09
From device on:	TC.LIN S/N: 1026LR028
FOR THE FOLLOWING COMPONENTS:	
<i>TC.LIN.SER</i> <i>Lin. Post-Processing Unit</i>	Versions: TC.LIN.SER.26.1000.26 TC.LIN.SER.40.1000.40 TC.LIN.SER.45.1000.45
FOR FIRMWARE (USE THIS CONFIGURATION FOR FULL FUNCTIONALITY):	
TC.LIN.SER	DSP: v0.18 *
TopCon Power Supply	Main DSP: v4.15.12 * Peripheral DSP: v0.14
For PC software TopControl	v4.01.65 *
Required Options:	
Function engine	TFEAAPControl enabled

* Other configurations are possible, but there might be a reduction of full functionality.

This document is subject to technical change without prior notice.

Dear customer

We thank you for the confidence you have placed in our company and for the purchase of the **TC.LIN(.SER) linear post-processing unit** (linear post-processing unit, for series connection).

This manual will help you to become familiar with the device and to obtain optimum performance from it. The TC.LIN linear post-processing unit is to be installed and commissioned by appropriately trained personnel.

These operating instructions are aimed at professional users and utilise corresponding terminology and language. Operation by technical laypersons is not foreseen.

Getting started

Please take the time to read the operating instructions carefully. The following sections contain important information on making the device ready for operation:

Information on mounting and installation → Sec. 3.2.2, p. 21

Commissioning / getting started → Sec. 3.4.1, p. 27

If you follow the information given in these instructions, you will save time and possibly avoid unnecessary queries during commissioning. Knowledge of these operating instructions is important also because improper usage may cause damage both to the device and to the loads connected to it, as well as to other parts of the system. The operating voltage of this device also represents a risk of injury or even mortal danger!

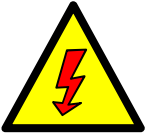

Should, despite studying these operating instructions and the instructions for the TopCon power supply used to supply it, questions arise, please contact your distributor. He/she will be pleased to help you with answers to your questions.

You can contact the manufacturer of the device at the following address:

Regatron AG
Kirchstrasse 11
CH-9400 Rorschach

Telephone: +41 71 846 67 44 E-mail: tc.support@regatron.ch

Fax: +41 71 846 67 77 Internet: www.regatron.com

Note

TopCon power supplies are built-in devices and have a fixed connection to the electrical supply system. Such devices must be correctly mounted and installed in compliance with the applicable regulations and standards by appropriately trained personnel.

The devices are prepared so that they can be installed, wired and interference suppressed in accordance with the applicable regulations with as little effort as possible. For this purpose the generally applicable regulations as well as the installation and connection information in these operating instructions are to be taken into account in full.

As the **TC.LIN linear post-processing unit** (short: "TC.LIN") only operates in conjunction with one or more **TopCon DC power supplies**, the related operating instructions for the power supplies also apply. In particular, the related safety measures for both the power supplies and also the TC.LIN are to be followed.

Table of contents

1. General information on the user manual	7
1.1. General safety instructions.....	7
1.2. Symbols used	7
1.3. Abbreviations / glossary	8
2. Introduction.....	9
2.1. General information	9
2.1.1. The TC.LIN(.SER) linear post-processing unit: overview.....	9
2.1.2. Model range.....	10
2.1.3. Parameterization and system communication	11
2.1.4. Principle of operation: control and internal controller structure.....	11
2.1.5. Limits on the use / functionality	12
3. The TC.LIN linear post-processing unit	13
3.1. Technical data	13
3.1.1. Device layout / views of the device	13
3.1.2. Mains connection (auxiliary voltage)	14
3.1.3. Power input and output.....	14
3.1.4. Control	14
3.1.5. Protection functions	15
3.1.6. Ambient conditions / cooling.....	15
3.1.7. RS232 interface (X100).....	16
3.1.8. CAN interface (X101, X102).....	17
3.1.9. Analogue and digital inputs and outputs (X105A)	18
3.1.10. Mechanical properties: dimensions	20
3.2. Commissioning -	21
3.2.1. Installation instructions	21
3.2.2. Electrical connections.....	21
3.3. TC.LIN master/slave systems	24
3.3.1. Cabling	24
3.3.2. Setting / Changing the module ID of the TC.LIN	26
3.4. Operations - basic.....	27
3.4.1. Getting started – overview.....	27
3.4.2. Hardware wiring/cabling	27
3.4.3. TC.P and TC.LIN setting correctly up (configuration)	27
3.4.4. Power-on process for the TopCon / TC.LIN combination	29
3.4.5. Loading an AAP characteristic into the TopCon power supply	29
3.4.6. Setting the preset voltage.....	31
3.4.7. Switching on the output power	33
3.4.8. Presentation of current and voltage values	33
3.5. Operation – advanced aspects	34
3.5.1. Modification of the TC.LIN parameters.....	34
3.5.2. Parameter setting for the TopCon power supply device	35
3.5.3. Parameter settings for linear post-processing unit.....	36
3.5.4. Notes on setting the controller parameters for the TC.LIN.....	37
3.5.5. Special controller parameters: Solar Array Simulation.....	37
3.5.6. Switching of the used current range.....	38
3.5.7. Storing / Reloading a TC.LIN system configuration	40
3.6. Maintenance.....	41
3.6.1. Maintenance of the hardware	41
3.6.2. Maintenance of the software	41
3.6.3. Calibration: adjusting the controller parameters.....	41
3.6.4. Warnings, errors and troubleshooting	42

- 3.6.5. Error and warning codes for the TC.LIN..... 44
- 4. Various other notes46**
 - 4.1. Emission of noise, gas, radiation 46
 - 4.2. Storage and protection during breaks in usage 46
 - 4.3. Returning the device..... 46
 - 4.4. Disposal 46
- 5. Appendix47**
 - 5.1. Overvoltage protection for firmware prior to version v0.18 47
 - 5.2. Calibration: voltage and current range measurement 48
- 6. Index.....49**

1. General information on the user manual

1.1. General safety instructions



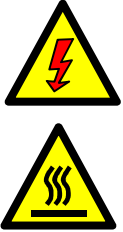



Please note the following general safety instructions:



- The TC.LIN linear post-processing unit operates with voltages up to 1000 Volt DC on its input and output terminals.
- It is to be noted that this high voltage is also present at the sense connections.
- The heat sink on the rear of the device is at a temperature of up to 70°C.

1.2. Symbols used

Important information in these operating instructions is marked with the following symbols:

Symbol	Significance
	<p>Instructions</p> <p>Here you will find useful information that is imperative to be followed during the usage and operation of the device.</p>
	<p>Warning – electricity</p> <p>Specific warning about electricity that if disregarded represents a hazard for the health or a risk of serious injury, and that if disregarded could result in possibly irreparable damage to the devices or other items.</p>
	<p>Warning – heat</p> <p>Specific warning about heat that if disregarded represents a hazard for the health or a risk of serious injury, and that if disregarded could result in possibly irreparable damage to the devices or other items.</p>
	<p>Prohibition</p> <p>Incorrect actions may result in damage to the device</p>
	<p>Version dependency</p> <p>For this (new) function or characteristic, please ensure you have the correct version of the software or firmware.</p>
	<p>Tip</p> <p>The sections marked with this symbol will help you to work efficiently with the TopCon device.</p> <p>In many cases they contain answers to frequently asked questions (FAQ).</p>
	<p>Process</p> <p>This pictogram is used to indicate processes that should or must be undertaken in a specific order.</p>
	<p>Mark</p> <p>Mark(s) in figures that are referred to in the text.</p>

1.3. Abbreviations / glossary

Abbreviation / term	Significance / explanation
AAP	Application Area Programming Function engine mode in which two non-time-dependent variables are defined in a relationship (e.g. $I = f(V)$)
CAN	Controller Area Network Here: communication bus between TopCon devices, such as TC.P and TC.LIN
DAC	Digital-Analogue Converter
DSP	Digital Signal Processor Microprocessor with additional interface functionality and expanded command set. Typical functions from the "signal processing" area, e.g. FFT analysis.
DSR	DataSet Ready: Signal on the RS232 interface
DTR	DataTerminal Ready: Signal on the RS232 interface
FFT	Fast Fourier Transformation (spec. frequency analysis)
HMI	Human Machine Interface Graphic user interface with LCD and rotary selector knob
LCD	Liquid Crystal Display
MPP	Maximum Power Point Point of greatest power consumption or transfer
MPP Tracker	Assembly or algorithm that controls the operating point of the inverter in relation to the MPP.
n.c.	Not connected
n.f.	No function
PCB	Printed Circuit Board
PE	Protected Earth
PWM	Pulse-Width Modulated signal
SOA	Safe Operating Area
TC.LIN (.SER)	Code for linear post-processing unit Here: only the model TC.LIN.SER (serial version) is covered in this document, hence commonly the ".SER" appendix is omitted.
TC.P	TopCon DC power supply
TFE	TopCon Function Engine (internal function engine in the TopCon power supply)

2. Introduction

2.1. General information

2.1.1. The TC.LIN(.SER) linear post-processing unit: overview

Motivation: usage in solar array simulation "scenario"

In many applications the dynamic control performance of the TopCon DC power supply is completely adequate for the required application. An example is Solar Array Simulation (SAS). The function engine, TFE, built into the power supply permits, with the AAP functionality, the simulation of the behaviour of a solar panel ($I=f(V)$ characteristic). The general function, quality, efficiency as well as other characteristics of the inverter can be tested and measured.

Some inverter models require a dynamic performance closer to reality for the optimum function of their MPP tracker; this performance is achieved by connecting in series a linear-controlled series controller. The TC.LIN linear post-processing unit contains, along with a highly dynamic linear power stage, a very fast digital control structure that, combined with the power supply, provides the required improvement in dynamic performance.

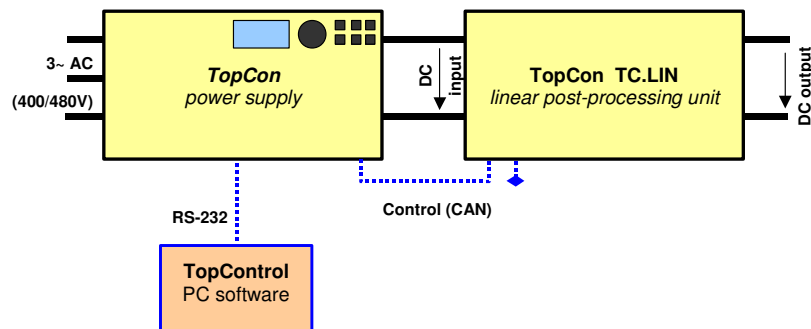

Fig. 1 Sketch of the combination of TopCon TC.P and TC.LIN

Layout in principle

The TC.LIN linear post-processing unit contains a digital signal processor that performs the control tasks and also administers all communication. The control tasks include the regulation of the power stage. All interfaces and user interface elements are electrically isolated from the controller/power board for safety reasons.

The interface board contains 4 different interfaces (cf. Fig. 2):

The first two interfaces are CAN bus interfaces that are provided for the communication with the TopCon master device and also other TC.LIN devices. Data exchange and the *standard parameter setup* for the unit is undertaken via this interface. Parameterization is undertaken directly via the TopCon master power supply and the system CAN bus. If there are no other devices on the CAN bus, the open bus connection is terminated using a CAN Term connector (the same as in a TC.P master/slave system).

There is also an RS-232 interface via which the *special parameterization variables* and *new firmware* can be written to the device. Setting standard parameters in TC.LIN uses the “transparent” data transport offered by the TopControl software.

The third interface (available at PCB v03, planned for 2011) is an analogue/digital interface. This will allow to *input and output signals* directly from the post-processing unit, which will make it possible to use this device in other settings.

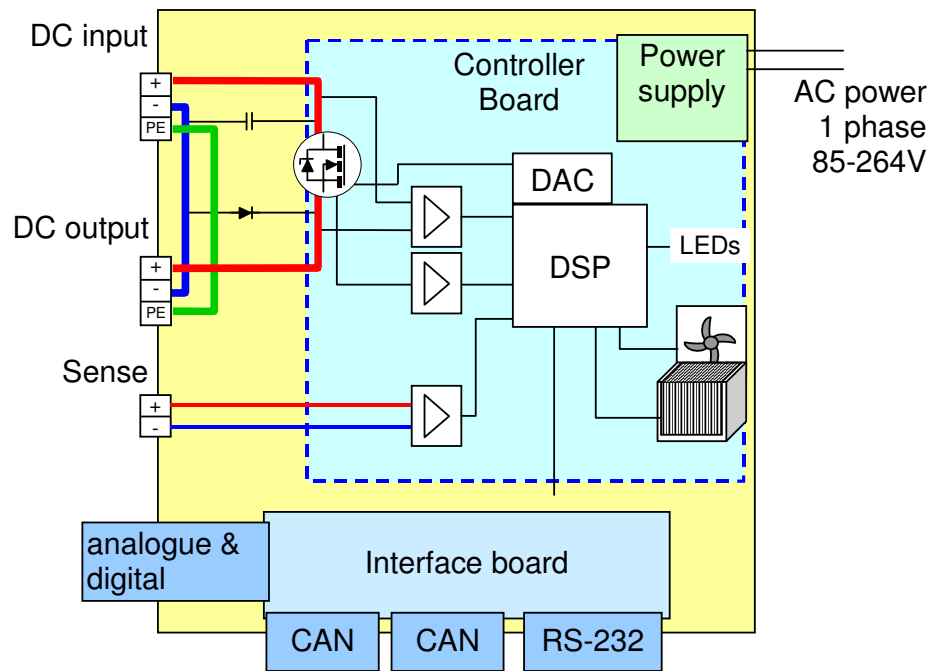

Fig. 2 Block diagram of TC.LIN

2.1.2. Model range

The following table lists the models in the TC.LIN family. Other models with different characteristics compared to the standard models are available on request. The related modified data will then apply.

Input current [A]	Input voltage [V]	Output current [A]	Type identifier
13/ 26 ¹⁾	1000	13/ 26 ¹⁾	TC.LIN.SER.26.1000.26
20/ 40 ¹⁾	1000	20/ 40 ¹⁾	TC.LIN.SER.40.1000.40
22/ 45 ¹⁾	1000	22/ 45 ¹⁾	TC.LIN.SER.45.1000.45

¹⁾ The first value relates to the "half range of current" setting, the second to the "full range".

Table 1 TopCon TC.LIN model range

Systems with higher power characteristics can be realised by connecting various TC.LIN in parallel (cf. chapter 3.3).

2.1.3. Parameterization and system communication

Between TC.P and the TC.LIN linear post-processing unit, communication is realised via an internal CAN communication interface. During this process a protocol similar to that in a TopCon power supply master-slave system is used. For the calculation of the maximum data transmission rate of the CAN bus, the TC.LIN counts as a normal bus sharing unit.

The TC.LIN requires two different classes of information for the implementation of the control:

- The AAP curve as the primary preset for the control
- Controller parameters that affect the dynamic performance of the control

The APP curve on which the control is based is sent digitally by the TopCon master power supply to the TC.LIN directly after the "Voltage On" signal is provided and after all changes to the AAP curve. The curve is stored temporarily in the TC.LIN memory. As a consequence it is lost once the device is switched off. It can be saved in the flash memory in the TopCon power supply, however it can also be loaded into the power supply using the TopControl software and is then sent later from there to the TC.LIN.

The function parameters for the TC.LIN linear post-processing unit are set with the aid of the TopControl PC software, just like the parameters for the supplying TopCon power supplies. These parameters are forwarded transparently to the TC.LIN. All parameters are saved in non-volatile memory with the aid of the [Store settings] button.

Transparent distribution has not been implemented for all parameters in the first generation of TC.LIN systems. For this reason some rarely used parameters must be stored in the TC.LIN (with TopControl directly attached to the TC.LIN module).

2.1.4. Principle of operation: control and internal controller structure

The TC.LIN linear post-processing unit contains a powerful DSP, which undertakes the control. Reference value for the control is the voltage present at the load. It is fed via the sense cable both to the TC.LIN linear post-processing unit and also to the TopCon power supply and is used as the basis for the AAP function (independent variable).

The TC.LIN linear post-processing unit receives the related new data via the CAN bus after the "Voltage On" signal is provided, and on each change to the characteristic. For the current control in the TC.LIN to operate free of distortion, the voltage output by the TopCon power supply must be higher (V_{drop}) than the voltage last used at the load. The difference is used as the controller amplitude reserve for the fast TC.LIN linear post-processing unit. Typical values of U_{drop} are 40V to 50V.

Current control and voltage control

In general TC.LIN works as current controller, e.g. it controls the current in relation to the sensed voltage. For very small currents (= high impedance an side of the load), there possibly exists an inaccuracy of the

current control based on the variance of electronic components and of calibration. In this case the TC.LIN switches to voltage control mode to prevent from unwanted behaviour like high voltage peaks. The voltage controller cuts-off the voltage at a level of the highest value of the $I = f(U)$ characteristics. This fixes the output signal to stay on the characteristic Solar Array Simulation curve.

Additional information:

The switch between the current control mode and voltage control mode is implemented by applying a hysteresis curve. It can be reprogrammed.

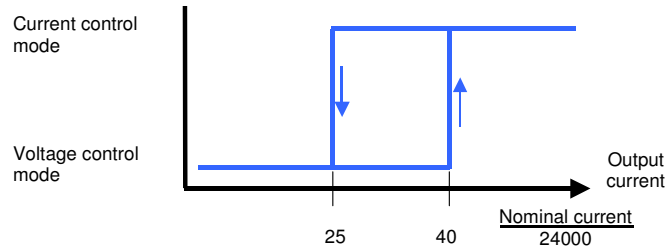

Fig. 3 Switching hysteresis between current and voltage control

2.1.5. Limits on the use / functionality

The TC.LIN linear post-processing unit receives the necessary functional data from the supplying TopCon DC power supply on system start and can therefore not be operated on its own or with another power supply. Correct and safe operation is only ensured if all information in these operating instructions, particularly on the wiring, is followed. Correct operation also requires a sufficiently high input voltage and input power from the DC power supply.

3. The TC.LIN linear post-processing unit

3.1. Technical data

3.1.1. Device layout / views of the device

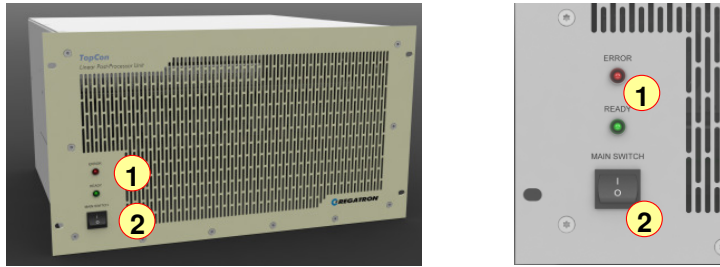

Fig. 4 Front view (left: overall view, right: close-up of user interface elements)

Front of device / user interface TC.LIN (cf. Fig. 4)	
1	ERROR LED (error indicator, error message is output on the TopCon master) READY LED (ready for operation indication)
2	Main switch, electrical power supply

Table 2 Front of device

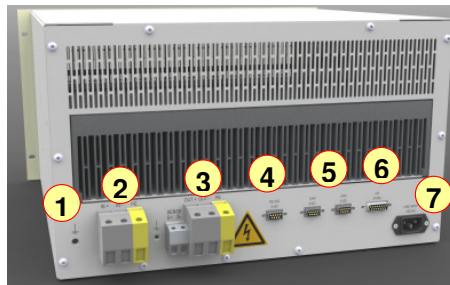

Fig. 5 Rear of device

Rear of device TC.LIN (cf. Fig. 5)	
1	Earth connection (e.g. for earth connection strap) ²⁾
2	Input: IN+ IN- PE ¹⁾
3	X104: Sense connection ¹⁾ and output: OUT+ OUT- PE ¹⁾
4	X100: RS232 parameterization and update interface
5	X101 / X102 ²⁾ : CAN communication interface
6	X105A: Analogue / digital interface ²⁾
7	IEC C14 chassis plug for internal electrical power supply
¹⁾ Attention: Pay attention to correct polarity! Up to 1000V present! ²⁾ Not implemented in prototypes.	

Table 3 Rear of device TC.LIN

Detailed information on the connection of the inputs in conjunction with the TopCon power supply is given in Section 3.2.2, p.21 ff..

3.1.2. Mains connection (auxiliary voltage)

The linear post-processing unit requires a dedicated single phase electrical power supply.

For the connection to the mains, an IEC C14 chassis plug is built into the housing (see Fig. 5, no. 7). The connection is made using a commercially available cable with IEC C13 plug to suit the country in which the device is used.

Variables	Value range / comment
Input voltage	85 ... 264V AC (1~)
Frequency	48 ... 62 Hz
Input power	100 ... 150 Watt (see data sheet)

Table 4 Mains connection / auxiliary voltage

3.1.3. Power input and output

The following cross-sections and types of isolation are to be used to wire the inputs and outputs:

TC.LIN type	Values
Input / output: Nominal current 26 A Nominal current 40 A Nominal current 45 A	Min. cable cross-section (load) 6 mm ² 10 mm ²
Input: Input voltage	0 ... 1000V
Output: Output capacitance	< 10 nF

Table 5 Characteristic data for power input and output (extract from data sheet)

3.1.4. Control

Variables	Value
Response times: Load regulation Line regulation	< 10 μ s ¹⁾ < 50 μ s ¹⁾
Resolution A/D conversion	14.5 bits (= 12 bits + 2.5 bits oversampling)
Operating modes AAP current control	With value range: 0 ... 100% I _{max}
¹⁾ For exact information: see data sheet	

Table 6 Characteristic data for control

3.1.5. Protection functions

The following monitoring and protection functions are implemented in the TC.LIN:

Name	Explanation / default limit
Overcurrent error	Output current $ActI_{Output}$ exceeds the value $MaxI_{Output}$ → Power stage switches off → leads to error state (overcurrent, error group 2) Default: $MaxI_{Output} = 120\% I_{nom}$ (or $60\% I_{nom}$ in alternative current range configuration)
Overvoltage error	Output voltage $ActU_{Output}$ exceeds the value $MaxU_{Output}$ → Power stage switches off → leads to error state (overvoltage, error group 3) Default: $MaxV_{Output} = 110\% V_{nom}$
Overtemperature error	Maximum temperature exceeding at 2 heat sink measuring points and/or at 1 PCB measuring point → leads to error state (error group 5)
SOA (Safe Operating Area)	Power loss on the power stage (MOSFET) → leads to error state (error group 2)
Supply voltage error	The supply voltage for the controller (+/- 5V, +/- 15V) is monitored for excessively high and excessively low voltages (leaving +/- 10% range) → leads to error state (error group 4)

Table 7 Protection functionality in TC.LIN

3.1.6. Ambient conditions / cooling

Variables	Value
Standard operating temperature [°C]	5 ... 40
Atmospheric humidity [%]	0 ... 95 (non-condensing)
Fans	Regulated: dependent on the heat sink temperature Characteristic: adjustable (see below)

Table 8 Characteristic data for environment / cooling

The fan control is dependent on the temperature of the heat sink (see Fig. 6) and can be modified in the factory using the corresponding parameters.

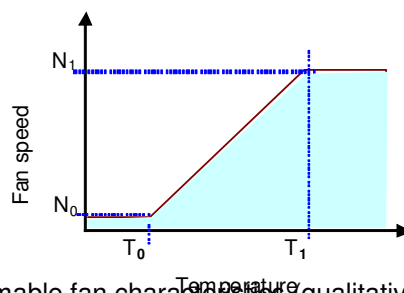

Fig. 6 Programmable fan characteristics (qualitative representation)

The following characteristics is set as factory default:

Variables	Value	Unit
T0	40	Celsius
T1	60	Celsius
N0	0	% of max. fan speed
N1	100	% of max. fan speed

Table 9 Parameters for the default fan characteristics

3.1.7. RS232 interface (X100)

- See Fig. 5 (4)

The RS-232 interface (X100) fitted to the rear of the TC.LIN is used to configure and parameterize the linear post-processing unit.

In principle the parameters are set using the TopControl software, i.e. on the TopCon power supply and transmitted via the CAN bus to the TC.LIN.

Software updates and certain special parameterization functions are however undertaken using this RS-232 interface (X100) on the TC.LIN.

The interface operates with the following **transmission parameters**, like the **RS-232 interface** on the power supply:

- 38.4 kB/s, 8 data bits, 1 stop bit, no parity, no software handshake

Pin	Signal	I/O	Description
1			n.c. (=not connected)
2	TXD	O	Transmit data
3	RXD	I	Receive data
4			n.f. (DTR, connected internally, however no function)
5	GND	-	Common ground
6			n.f. (DSR, connected internally, however no function)
7			n.c.
8			n.c.
9			n.c.
-	Shield		Connector housing is connected to PE.

Table 10 Pin assignment for the RS-232 interface (X100)

3.1.8. CAN interface (X101, X102)

- See Fig. 5 (5)

The connection between two devices in the TopCon family is made using the REGATRON CAN communication cable (items supplied). The second interface is terminated at the end of the bus using a "CANTerm" connector. This situation applies in particular also for a master/slave system with one TopCon power supply and one TC.LIN linear post-processing unit.

As alternative to the termination of the bus, the CAN bus can be linked to the next device using a further CAN cable.

The built-in CAN interface (X101 or X102) makes it possible to transmit standard parameters and controller presets from the TopCon master to the post-processing unit. For example, the definition of the characteristic curve is copied to the TC.LIN. This configuration makes it possible for the linear post-processing unit to implement control locally without communication latency. In addition, measured values are transmitted in the opposite direction from the TC.LIN to the TopCon master (future application).

Pin	Signal	I/O	Description
1	(Interlock)		(Interlock) ¹⁾
2	CAN_L	I/O	CAN low
3	GND_CAN	O	CAN reference potential (cf. pin 6)
4	n.c.		
5	n.c.		
6	GND_CAN	O	CAN reference potential (cf. pin 3)
7	CAN_H	I/O	CAN high
8	GND_IO	O	Auxiliary voltage reference potential
9	24V_IO	O	Auxiliary voltage + 24V DC
	Shield		(Connected to earth)
¹⁾ Interlock loop (direct connection X101/pin1 – X102/pin1).			

Table 11 Pin assignment for the CAN interface X101/X102

3.1.9. Analogue and digital inputs and outputs (X105A)

- See Fig. 5 (6)



Note: The firmware of the analogue and digital interface (X105A) has not yet been implemented (status: Nov. 2009). Nevertheless the hardware implemented is fully functional.

The analogue and digital IO connection is a 15-pin D-SUB connector (female) on the rear of the device (see Fig. 5, p. 13).

Pin	Signal	I/O	Description
1	AGND		Reference potential for analogue and PWM signals
2	PWM_Out_2	O	(referred to AGND)
3	PWM_Out_1	O	(referred to AGND)
4	n.c.		-
5	App_Dig_IN	I	(cf. pin 15)
6	Dig_Out_1a	O	(cf. pin 13)
7	n.c.		-
8	24V_IO		+24 V supply voltage
9	App_Analog_Out_2	O	(referred to AGND)
10	App_Analog_Out_1	O	(referred to AGND)
11	AGND		Connected to pin1 (ref. pot.)
12	n.c.		-
13	Dig_Out_1b	O	(cf. pin 5)
14	n.c.		-
15	GND_IO		Reference potential for pin 5

Table 12 Pin assignment analogue/digital IO port X105A (cf. Fig. 5)

Notes on the signals

- Remark on EMC

It is assumed that the length of the connections to the analogue I/O interface do not exceed the length of 3m. This allows to leave out several EMC related tests. Further information are available from the manufacturer.

- Analogue and PWM outputs 1 and 2:

On the outputs PWM_out and App_Analog_Out_x (x=1|2) values measured internally are represented as a pulse-width modulated signal and as an analogue voltage respectively.

The App_Analog_Out_x signals are related to the PWM_Out_x signals as follows:

The PWM signal is converted to the related analogue signal via an active 2nd order filter (active low pass filter).

The PWM signal provides approximately 1mV resolution (10.000 steps between 0 and 100%).

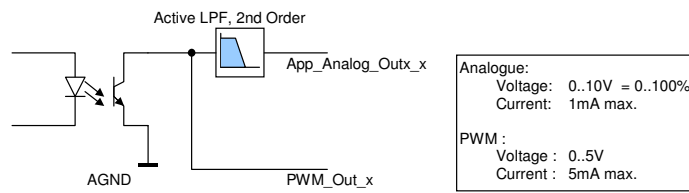

Fig. 7 Schematic diagram: App_Analog_out_x and PWM_Out_x

- Digital output (Dig_Out_1a / 1b)

The digital output is electrically isolated from the TC.LIN and allows to drive or to pull the load. Thus a connection between Dig_Out_1a to +voltage respectively Dig_Out_1b to GND is needed.

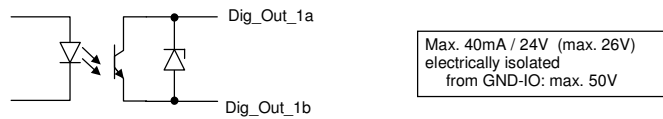

Fig. 8 Schematic diagram: Digital_Out

- Digital input (App_Dig_IN)

The digital input is electrically isolated from the remaining part of the TC.LIN. It allows the input of signals for the analysis with special firmware. The design allows to control the input by a driven or pulled input signal.

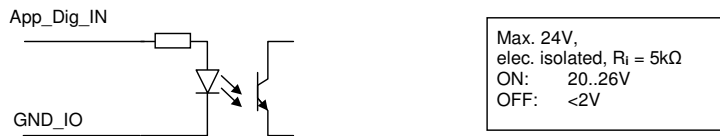

Fig. 9 Schematic diagram: Input circuit Digital_IN

3.1.10. Mechanical properties: dimensions

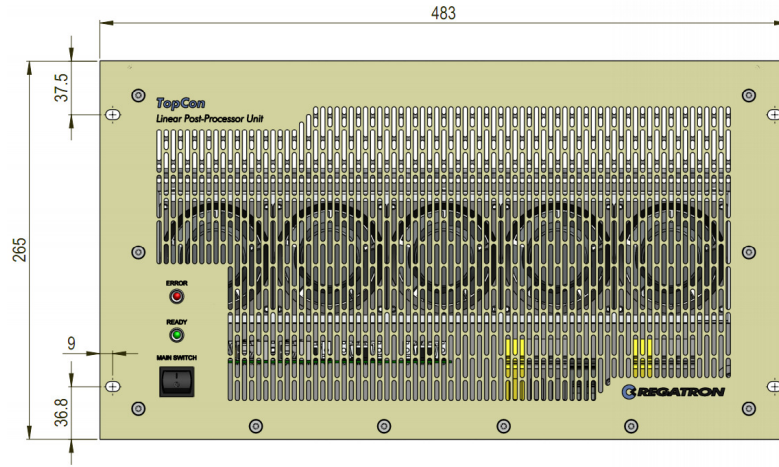

Fig. 10 Dimensions, front

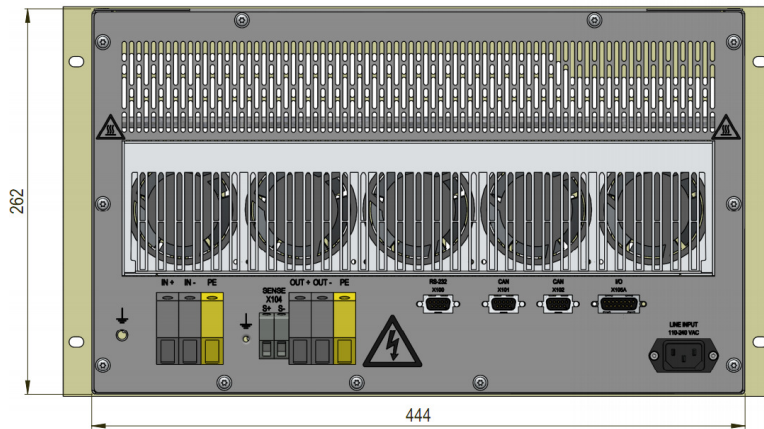

Fig. 11 Dimensions, rear

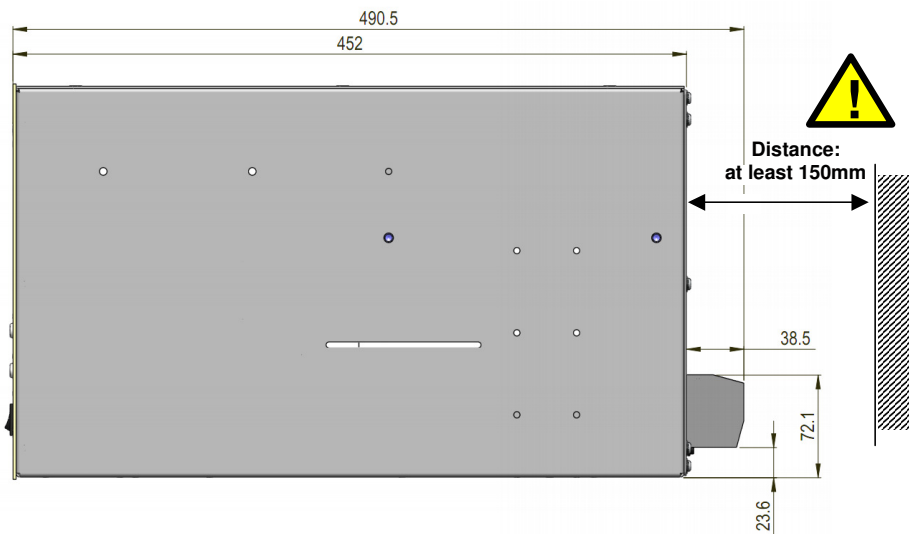

Fig. 12 Dimensions, side

3.2. Commissioning -

3.2.1. Installation instructions

Mechanical installation / transport / support

The TC.LIN linear post-processing unit is prepared for installation in a 19" cabinet. The supporting surface on which it is placed is to be large enough that the housing does not protrude at the side and is not subjected to point loads.

The device is not allowed to be subject to heavy vibration or shaking either during transport or during subsequent use.

Ventilation / covering

The TC.LIN linear post-processing unit converts the power loss that occurs in the control elements during control into heat. The heat is dissipated to the environment via a heat sink on the rear of the device (see Fig. 5). The device contains several fans that draw in air at the front of the housing, guide it through the main heat sink and discharge it at the rear.

The heat sink is not allowed to be touched, because it can have a temperature of about 70°C.

Also, neither the front nor the rear of the housing is allowed to be covered such that the air circulation is hindered. Direct air circulation from outlet to the inlet (shortcut) is to be avoided. At the front and rear a minimum clearance of 150 mm to the nearest object must be maintained (see Fig. 12).

An overtemperature will result in the shut down of the TC.LIN (see possible error causes). The related data are transmitted to the Topcon master and displayed there as warning or as error.



3.2.2. Electrical connections

3.2.2.1. Electrical installation – overview

The usage of the TC.LIN linear post-processing unit requires a number of connections between the power supply, the TC.LIN linear post-processing unit, a control PC with the TopControl software and the load.

The following connections must be made - explanations on the various connections are given in the following paragraphs:

- At the TopCon power supply:
 - Connection of the mains supply (3~ 400/480 V) and PE
 - Attaching the 9-pole plug "CANTerm with Interlock" to the X101 (or X102) Interface
 - Attaching the 25-pole plug "Interlock" to the X105 interface
- ...
- Between TopCon and TC.LIN:

- Connection of the load connectors (+) and (-) and PE
 - TopCon CAN communication cable (identical to CAN communication cable for connection between TopCon power supplies)
 - Between TopCon and load:
 - Sense connection (2 core, shield connected to PE)
 - Between TC.LIN and load:
 - Connection of the load connections (+) and (-) and PE
 - Sense connection (2 pins, shield connected to PE)
 - On the TC.LIN linear post-processing unit:
 - Termination of the CAN bus using CAN-Term connector (on prototype with only one CAN connector, the termination is built into the connector of the special CAN cable.)
- Attention:** There must be exactly one “CANTerm-plug with Interlock” in the whole system, otherwise the Interlock functionality is not properly set up!
- Connection of the mains supply (1~ 85-264 V AC)
 - (Optional) between PC with TopControl software and TopCon:
 - RS-232 data cable (9-pin, Sub-D)

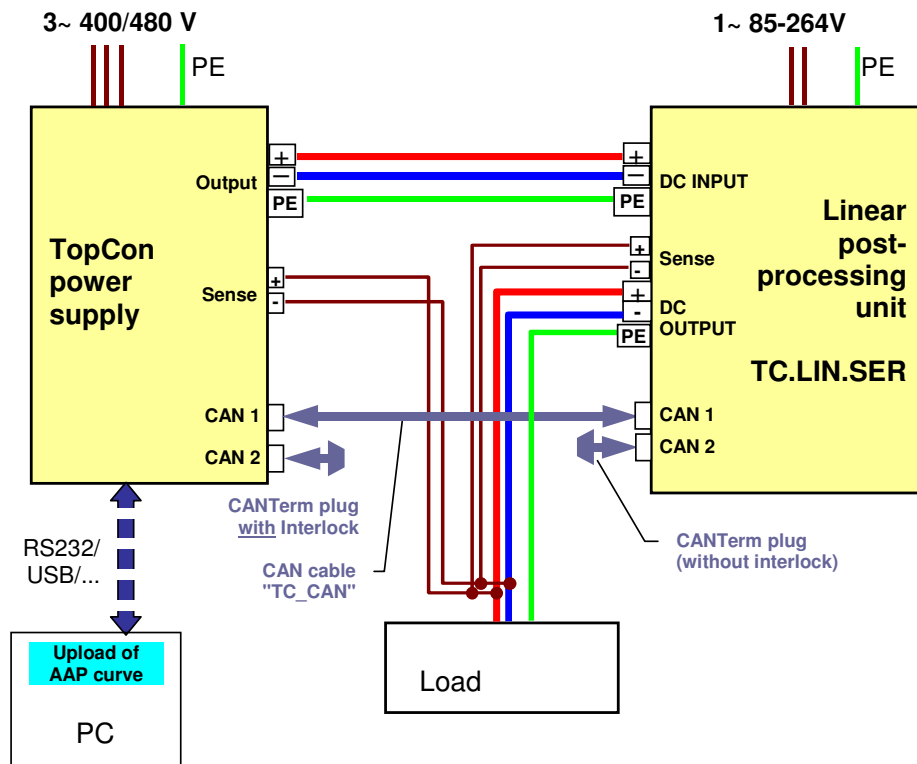

Fig. 13 Connection of TC.P, TC.LIN, load and control PC

3.2.2.2. Interlock

The linear post-processing unit does not have a dedicated interlock connection. As the output power always comes from an upstream DC power supply, it is sufficient if the interlock system in this system is used (see manual for TopCon power supply).

3.2.2.3. Sense

Only a minimal amount of power is transmitted over the sense cables. For this reason no requirements on the cross-section are specified. To avoid coupling of interference onto the wires, it is strongly recommended to use shielded cable.

It has to be remembered that sense voltage is up to 1000V !



TC.LIN type	Recommended cable (sense)
Nominal current [A] 26/40/45	2 x 0.5/0.8 mm ² with shield (strongly recommended)
Shield	Connection to the housing using M4 screw

Table 13 Properties of the sense connection

3.2.2.4. Analogue and digital IO connection (X105A)

Note: This interface is in planning.

The analogue and digital IO connection makes it possible to feed external signals to the TC.LIN or to output internal signals to the exterior.

The following interfaces are available (pin assignment: see Section 3.1.9, p. 18).

PWM signal (on this topic see also Sec. 3.1.9)

It is possible to output 2 values measured internally as a PWM signal on the interface.

Analogue output

The above mentioned PWM signal is smoothed using a low pass filter and is thus available as an analogue signal.

Digital I/O interface

An internal signal state can be output via the digital interface.

In addition, a digital value can be read.

The digital input and output interface is electrically isolated.

Explanation of the software aspects related to the X105a

(To follow later when implemented.)

3.2.2.5. Parameterization and control interface (X100: RS-232 interface)

On the rear of the housing there is an RS-232 interface. Using this interface it is possible to address directly the digital control structure. This feature is required, e.g., for a firmware update or to calibrate / parameterize the device.

The controller parameters and other parameters are set via the TopCon power supply (master). For this purpose the related CONFIG page is opened in the TopControl PC software (version required: cf. page 2), the parameters are entered directly online.

As a consequence the RS-232 interface on the TC.LIN is only used in a few cases.

3.2.2.6. System communication interface (X101/102: CAN)

All users on the CAN communication bus must have unique device addresses using which they are identified.

On the TopCon power supplies this address (Address High AH and Address Low AL) is set using rotary switches on the device's front panel.

For the TC.LIN the address set to 0 during manufacturing and can be modified using the TopControl PC software (cf. section 3.3.2).

3.3. TC.LIN master/slave systems

Several linear post-processing units are eligible to be connected in parallel to increase the power output of the system. The individual TC.LIN devices behave symmetrically in this situation, i.e. they operate with a symmetrical current distribution.



Remark: Due to the way, the sense voltage is used in a TopCon / TC.LIN system, it is not possible to implement a Serial – or a Matrix connected system in combination with a TC.LIN!

Remark: Make sure to use in the TopCon as well as in the TC.LIN modules the most up-to-date firmware!

3.3.1. Cabling

The parallel connection of several TopCons and of linear post-processing units (TC.LIN) is possible. For this to be achieved the involved TopCon modules are interlinked as parallel connected system. The common output (+, - lines) are connected in parallel with all inputs of the TC.LIN systems involved. Refer to Fig. 14 for a visual explanation.

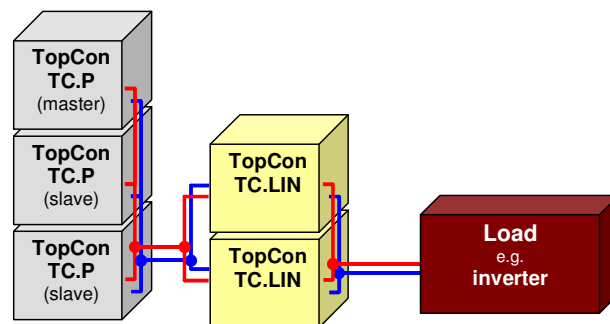

Fig. 14 Example power supply/post-processing unit master/slave system (with load)

The communications connection among the components is provided by a CANBus link between all devices, hence by repeatedly linking one

device with another (cf.). As it is a bus architecture, the particular link sequence of the devices in this bus structure has no particular effect.

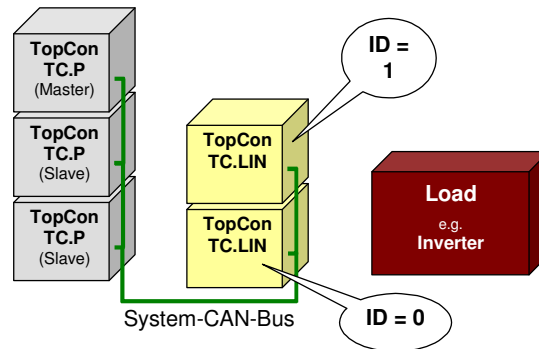

Fig. 15 All components of the system are linked by a non-public system CANBus

The IDs of the different TC.LIN modules must differ. There are no special requirements how to number the devices, except for being unique in the system. It is assumed that they are numbered sequentially, starting at 0 (cf. section 3.3.2 for direction how to change the ID). The addresses are used to identify the different TC.LIN modules and are automatically scanned by the TopCon master device during the power-on procedure. The ID is as well used to assign configuration parameters to the different TC.LIN modules.

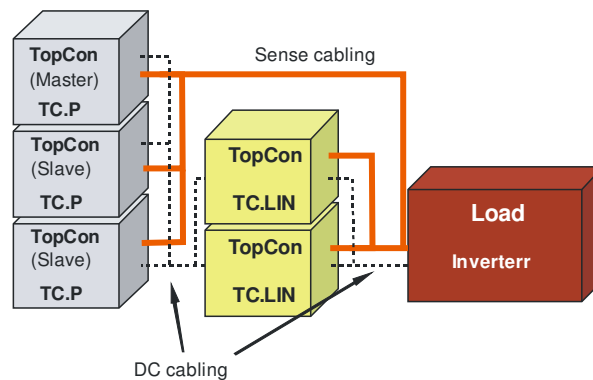

Fig. 16 Sense cabling with a multi-TopCon / multi-TC.LIN system

It is assumed that the sense cabling of all devices is led star-shaped to the load. But as no significant currents are used for sensing the voltage, there is hardly any voltage drop on the lines and the lines might follow a similar structure as depicted in Fig. 15. When encountering effects of noise (electrical interference), make sure to use the star-shaped cabling schema.

Concerning the parameterization of the different TC.LIN modules, it is strongly advised to use the same control parameters for all TC.LIN modules of the same kind (cf. to section 3.5.3 for directions how to change the parameters). This is best done by using the PC software TopControl.

3.3.2. Setting / Changing the module ID of the TC.LIN

Differing from the procedure known from installing a new ID at a TopCon device (changing the rotary switches AH/AL on the front plane of the TopCon device), setting the module ID of the TC.LIN device is achieved by a simple programming process. This requires a PC (with the software TopControl) to be connected to the RS232 interface of the TC.LIN. The procedure is as follows:

1. Connect TC.LIN to the mains. A connection to a DC source or load is not necessary for changing the ID.
2. Connect a PC with the software TopControl to the RS232 interface of the TC.LIN module (interface X100 on rear side of the TC.LIN).
3. After switching to "PowerUser" mode (please refer to TopCon support for the password of the day and the necessary so-called gridfile), the register card "Parameter" is available.
4. Please request from TopCon support (together with the password of the day, cf. 3) a gridfile to change the module ID. This is necessary to find the address of the correct variable in the TC.LIN device.
5. Change the value of the variable DefaultModuleID to the required value (= new value of the ID). Press [Write] to write this value to the TC.LIN device.
6. Click on the button [CopyEEToFlash] to store the changes permanently in the TC.LIN device.
(As alternative, the variable "EepromWriteConfigRequest" can be set to 1 and to be written to the device with clicking on [Write] button.
7. System-Restart (Switch off, wait until the LEDs went off, switch on) restarts the TC.LIN module with the new ID set properly.

3.4. Operations - basic

3.4.1. Getting started – overview

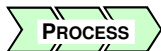

The usage of the TC.P / TC.LIN combination requires a special power-on sequence. This introductory section provides an overview of this power-on process. The individual steps are explained in the following sections.

Remark:

For further information on the configuration of the TC.LIN module ID number in multi unit systems, refer to section 3.3.2 on p. 26.

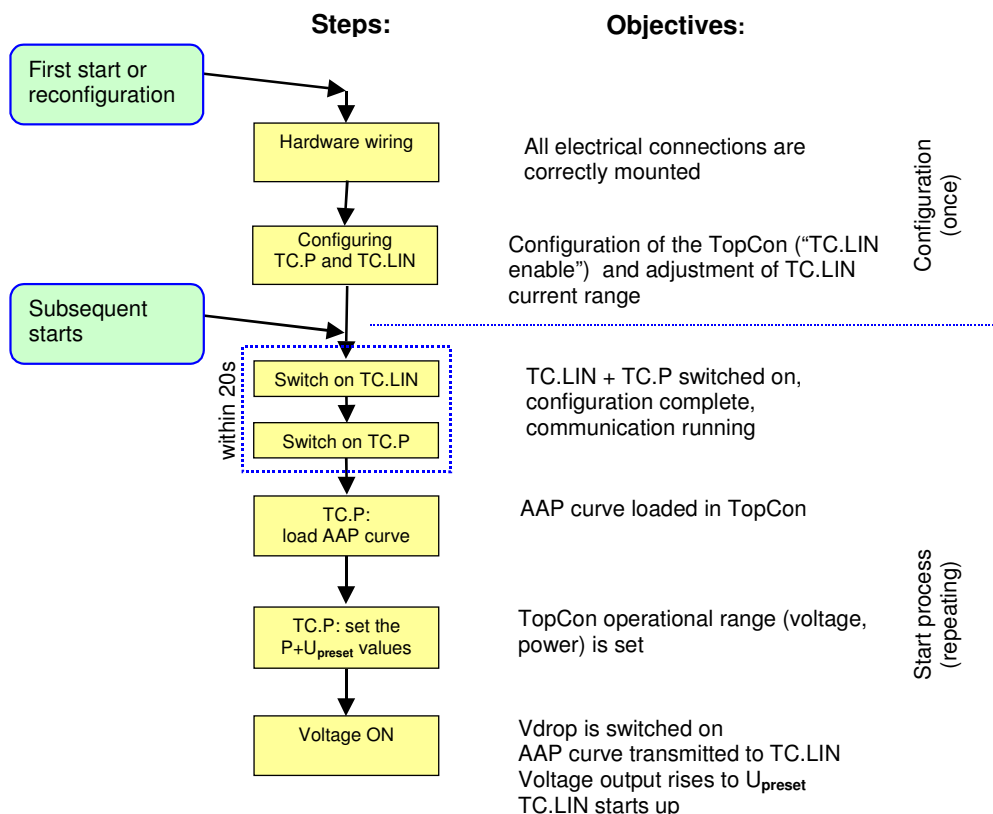

Fig. 17 Flowchart (with objectives) of power-on process for the TC.LIN / TC.P combination

3.4.2. Hardware wiring/cabling

Refer to section 3.2.2.1 (Electrical installation – overview, p. 21)

3.4.3. TC.P and TC.LIN setting correctly up (configuration)

During manufacturing, the TC.LIN is prepared for immediate use. Only under special circumstances arises the need for reconfiguration. In such cases the controlling TopCon power supply device is to be configured in a way that the attached TC.LIN is identified and the correct current range

is selected. When ordering a complete TC.P / TC.LIN system from Regatron, the correct settings are provided.

If necessary, the change of the configuration is achieved in the optimal way by using the PC software TopControl. In case that the attached TC.LIN modules need to be configured independently of each other, this can be managed by attaching and configuring the single devices with TopControl. Alternatively the changes can be achieved by manual modification of the TC.LIN parameter files (confer to section 3.5.6.3). Nevertheless the modification by using TopControl is the preferred way.

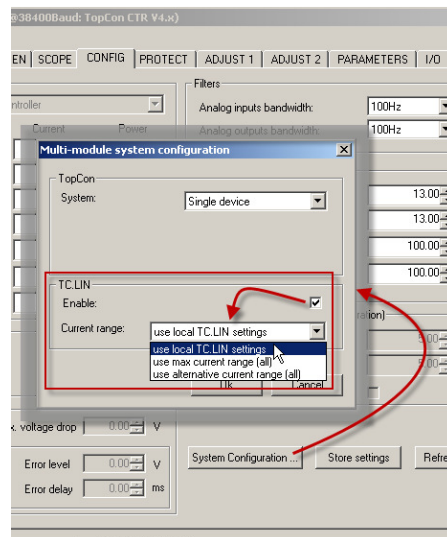

Fig. 18 Uniform configuration of one or more TC.LIN devices via TopControl software

Changing the current range is a change in the system configuration and thus needs access to the register card [tab: CONFIG].

Process:

Activate the “Advanced User” mode in the menu: [Menu: window] [Preferences...]. The required password is “kilowatt”. This mode does not expire and thus is valid until another change of the mode is initiated.

After restarting the TopCon system and a re-connect of TopControl with the TopCon device, the additional register cards [tab: CONFIG] and [tab: PROTECT] are at hand.

Clicking on the button [button: System Configuration...] opens up the configuration dialog that allows to uniformly manipulate the configuration of all attached TC.LINs (cf. Fig. 18).

The button “Enable” generally activates the use of the TC.LIN module with the TopCon device (1).

The activation of the “Enable” checkbox leads to the presentation of the dropdown box (2), that allows to select the current range to be used. The following options are available:

- [“use local TC.LIN settings”]
... this leaves the settings of the TC.LIN devices connected to this system as they are. This setting is needed if not all module should be set uniformly to one single setting (e.g. when using different types of TC.LINs in one system).

- ["use max current range [all] "]
... switches all connected TC.LIN devices to the maximum current range.
- ["use alternative current range [all]"]
... switches all connected TC.LIN devices to the alternative (= "half") current range.

Confirmation of the selection by pressing [OK] leads to a restart of the TopCon / TC.LIN system. This activates the new settings.

In case of special use, the following aspects have to be considered:

- For use in multi TC.LIN environments: cf. to section 3.3.2 (page 26)
- To enhance the resolution while working with very small currents (in mixed TC.LIN systems): cf. to section 3.5.6.

3.4.4. Power-on process for the TopCon / TC.LIN combination

As between the post-processing unit and the TopCon master power supply with master role, communication must be established using the internal CAN system communication, a specific sequence must be followed on switching on the devices:

Schritt 1. The main switch on the TC.LIN linear post-processing unit is switched on before or at the same time as the TopCon power supply (master).

Schritt 2. The main switch on the master must also be switched on within approx. 20 sec., so that the communication can be established and a CAN bus error does not occur.

The green "READY" light emitting diode on the front of the linear post-processing unit signals that communication has been started successfully.

In the case of an error, the red "ERROR" light emitting diode on the TC.LIN illuminates. The error is output on the TopCon power supply as a flashing code. In addition, plain text information is displayed directly in TopControl or, if the power supply is equipped with the HMI option, in the HMI (see operating instructions for TopCon power supply). In case of erroneous communication there may not be any detailed error indication on the master device. The TC.LIN does not indicate the error using a flashing code. The error can however be read using a TopControl application connected directly to the TC.LIN (interface X100). (Please request the password of the day, the necessary gridfile and further instructions at TopCon support.)

The TopCon master power supply now automatically detects the TC.LIN module connected and checks the related configuration (e.g. it checks whether duplicate addresses exist, monitors that the numbering for the sub-systems is sequential; etc. ...).

3.4.5. Loading an AAP characteristic into the TopCon power supply

Loading an AAP characteristic into the TopCon power supply and setting the related required parameters is described in detail in the operating

instructions for the TopCon power supply (Sec. 5.4.4 – "The slopes inside (of) the Application Area Programming (AAP)").

For this reason only the key points are given here in the context of an outline of the process for the Solar Array Simulation (SAS) area.

Concise instructions:

- Connect TC.LIN to TopCon power supply (CAN communication cable).
- Connect PC to the TopCon master power supply (RS-232 interface).
- Start TopControl on the PC, switch on remote access via RS-232 (CONTROL tab).
- The TFE option (TopCon Function Engine) must be activated in TopControl (see operating instructions).
- The function engine must be operated in the AAP mode (for settings see Fig. 19).
 - (1) Set the required function block for SAS: $I=f(V)$ characteristic → "Used Function Block" must be set to Current
 - (2) Select the Base Function for SAS: AAP
 - Define characteristic or edit points on the characteristic (2 → [Edit AAP]) → curve is now displayed in the graphic area
 - The curve can be manually scaled (3)
 - The display can be manually scaled (4)
 - If necessary, set Input Filter and Input Scale (scaling of the input value "voltage") (5)
 - Set trigger and prepare activation of the mode (6)
 - Alternatively an existing characteristic in the power supply can be opened using [Load from Flash...] (7).
 - [Voltage ON/OFF] on the [CONTROL tab] now starts the power supply; it then operates in the AAP mode

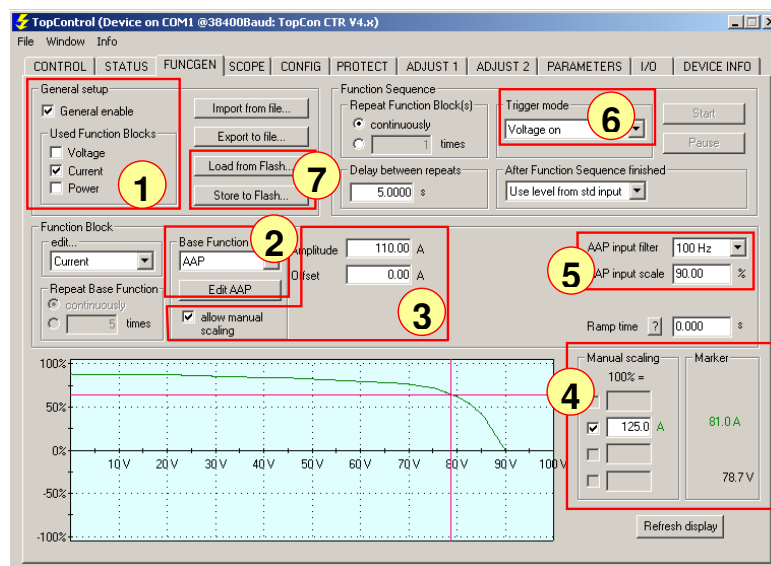

Fig. 19 Overview of the settings for the AAP mode in the function engine

Note:

Loading the AAP curve in the TopCon power supply has no effect on the linear post-processing unit. The characteristic is only transmitted to the TC.LIN and processed there on the "Voltage ON" command (refer to section 3.4.7 for a detailed explanation).

3.4.6. Setting the preset voltage

The TopControl PC software has a feature with which the voltage preset value that is applied for an existing AAP curve can be set (see Fig. 20: Setting the voltage preset value). The preset value for the current is managed by the function engine.

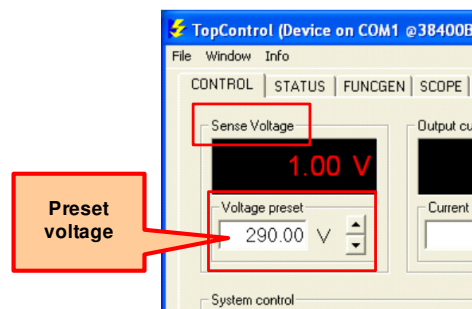

Fig. 20 The preset voltage defines the start setting for the voltage
(Actual value box: indicates the actual sense voltage!)

Rule of thumb for setting the preset values

Physical value has to be set to:
Voltage preset	A little bigger than the biggest value of U_{OC} ; Or simply $U_{PRESET} = U_{maxINV}$
Current preset	No need to set this: the value is ignored as it is controlled by the values of the AAP curve.
Power preset	This serves as load protection. For Solar Array Simulation: set this value to the maximum power of the inverter.

Table 1 Setting preset values (at the TopCon power supply)

Explanation of the preset voltage

The value for the preset voltage must satisfy the following equation:

$$V_{\text{preset}} \leq V_{\text{maxINV}}$$

where V_{maxINV} = maximum inverter voltage

At the same time it is necessary that the preset voltage of a correct configuration needs to be higher than the maximum voltage of an AAP characteristics (V_{oc}):

$$V_{\text{preset}} \leq V_{\text{oc}}$$

where V_{oc} = Maximum voltage of the AAP characteristics (voltage at open circuit conditions)

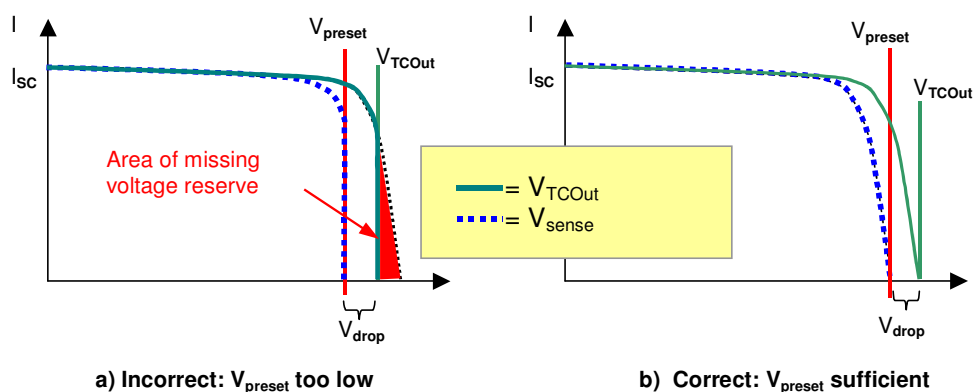

Fig. 21 Illustration to aid with the selection of the preset value

The effect of an erroneously set voltage is explained Fig. 21:

- V_{preset} too low: the AAP characteristic is distorted in the top part of the range (vertical boundary)
- V_{preset} correct: the controller amplitude reserve (dotted blue line) is sufficient at every point.

As the shape of the AAP curve can change (as result of changes of the irradiance, it is advised to set the preset voltage as follows:

$$V_{\text{preset}} = V_{\text{maxINV}}$$

There is then a sufficient voltage reserve at every operating point and the resulting operating curve follows the AAP preset. It may be necessary to raise the warning or error limits ("PROTECT" tab).

Practical advice

The value of the preset power limitation is a border that cannot be violated by the TopCon power supply (power limit). Reaching this limit is presented by the LED "Power" on the front of the TopCon power supply.

Choose the value of the power limitation in a way that the maximum power of your inverter is not exceeded. Thus we conclude:

$$P_{\text{preset}} = P_{\text{maxINV}}$$

It is up to the user to set a lower limit if that one should not be passed (for whatever reasons).

3.4.7. Switching on the output power

The start process ends with the powering up of the power stage.

The starting process from power-on [Voltage ON] can be seen in Fig. 22: in the first phase the voltage $V_{\text{actModule}}$ (top curve) increases to the value V_{drop} (e.g. 50V) for the linear post-processing unit (see (1) in Fig. 22). This value results from the measured sense voltage (output of TC.LIN is still blocked, hence output voltage is 0V) with the added drop voltage U_{drop} . This in total sums up to 50 Volts that is presented at the output of the TopCon device (not output of TC.LIN). During the subsequent phase lasting approx. 1s, among other tasks the AAP curve is transmitted to the TC.LIN (2).

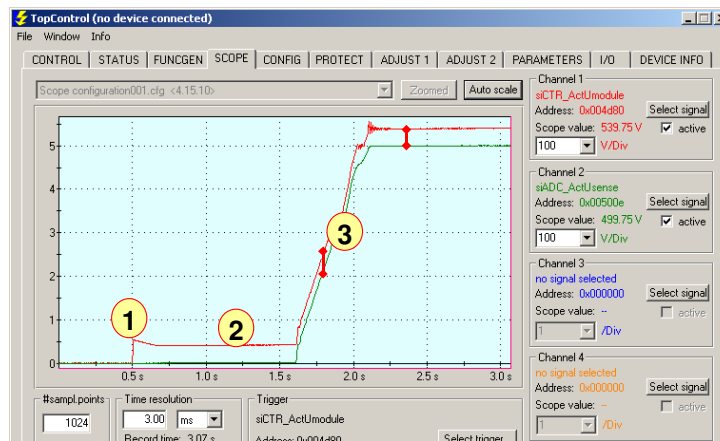

Fig. 22 Illustration of the switching-on process

After this period, the TC.LIN starts opens the control and the voltage at the output rises (3). This slope is a linear, adjustable function (start-up ramp, default duration = 1s) and prevents the output voltage from overshooting (cf. lower graph in Fig. 22). The output voltage on the TopCon power supply remains in this case constant at V_{drop} above the measured voltage (V_{sense}).

From now on the current is regulated by the TC.LIN based on the $I = f(V)$ curve.

3.4.8. Presentation of current and voltage values

The controller loop in the TC.LIN device is by far faster than the transmission of the actual values from the TC.LIN to the TopCon device. Thus a statistical value (mean, minimum and maximum) is calculated for a certain measurement period and these values are taken from the TopCon device and are presented in TopControl (or SASControl).

The two voltages “sense voltage” (measured in the TopCon device) and the “actual output voltage” (measured in the TC.LIN) are the same. Both values are available in the TopCon device.

Thus it would generally be possible to present the values of the TopCon sense voltage instead of the output values of the TC.LIN device. Nevertheless there is a slight difference between those values as the resolution of the TC.LIN is significantly higher than that of the TopCon device (14.5 bit vs. 12 bit resolution).

3.5. Operation – advanced aspects

In the following section tips are given on setting the controller parameters for the TopCon power supply and for the linear post-processing unit. The values are to be considered general figures.

3.5.1. Modification of the TC.LIN parameters



Please note!

Depending on the task, the PC is connected either *directly to the TopCon* or *directly to the TC.LIN*! The related form of connection is given in each case.

Commonly all adjustments to the TC.LIN device are set in the software TopControl running on a PC that is linked to the TopCon (!) device (cf. Fig. 23). The TC.LIN linear post-processing unit is connected to the power supply via the CAN-based communication bus. The data intended for the TC.LIN device are sent transparently by the power supply to the TC.LIN during the save process.

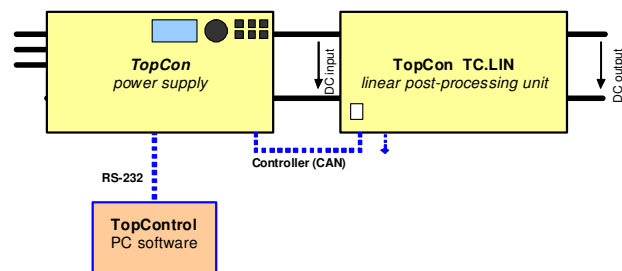

Fig. 23 Configuration for parameterization of the TC.LIN linear post-processing unit

Only in certain cases a direct link between the PC and the TC.LIN is necessary (configuration as depicted in Fig. 24).

Thus a firmware update, the change of the TC.LIN module ID or a change of the current range to be used (if not changed uniformly in TopControl for all connected TC.LIN devices) requires this type of connection.

The PC with the software TopControl has to be connected to the TC.LIN via the RS-232 interface (compare with the “common” connection of the PC, drafted in grey).

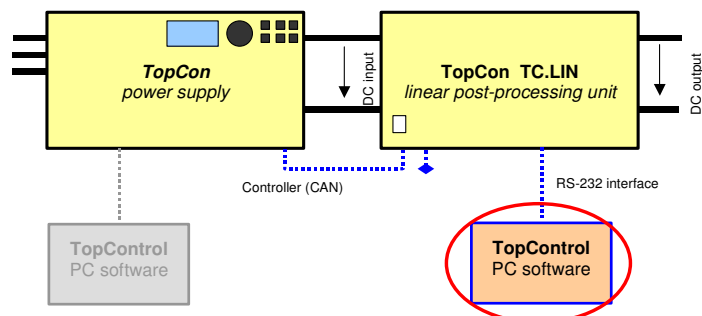

Fig. 24 Configuration for direct manipulation of TC.LIN variables

It is to be noted that a communication error will occur if you operate the TC.LIN on its own. For this reason the devices are always to be operated with a functional CAN connection.



Note:

If you want to edit the parameters in the linear post-processing unit with the power supply shut down or not present, after approx. 20s the TC.LIN will indicate a communication error. It is nevertheless possible to set the parameters. Other errors that occur can be read via the X100 interface on the TC.LIN.

3.5.2. Parameter setting for the TopCon power supply device

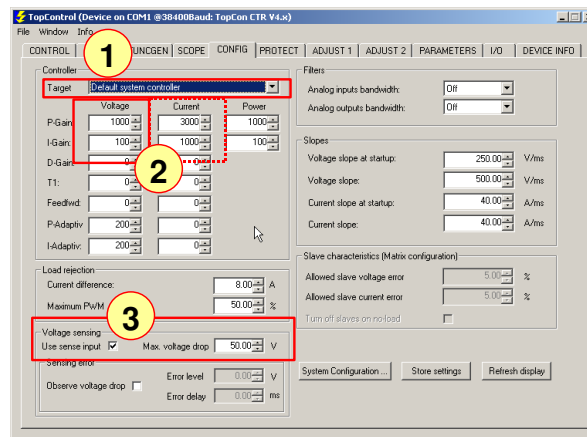

Fig. 25 Config window for TopCon master power supply



The following table (Table 14) describes the system parameters to be set on the [CONFIG] tab in TopControl. It is to be noted that during this process the system controller (not TCLIN !) is selected first. This controller is selected using the drop-down list (see (1), Fig.).

The next section describes how to set the parameters for the TC.LIN device.

No	Field	Values	Description
1	Target	Default System Controller	Selects the fields below for setting the <i>TopCon power supply</i> controller
2	P-Gain Voltage	1000 ¹⁾	P gain
	I-Gain Voltage	100 ¹⁾	I gain
3	Use sense Input	Selected	<u>Must</u> always be activated for operation with <i>linear post-processing unit</i>
	Max Drop Voltage	Typical value on operation with	
		50V ²⁾	TC.LIN.SER.26.1000.26
		40V ²⁾	TC.LIN.SER.40.1000.40
	35V ²⁾	TC.LIN.SER.45.1000.45	

1) Typical values for a wide range of applications.
 In case of oscillation on the output current from the TopCon power supply, these values can be reduced, e.g. to P=700, I=70.

2) Typical values, in case of high output currents the tendency must be to reduce the drop voltage so that the power loss is not excessive. If the drop voltage is selected too low, the *linear post-processing unit* will no longer be able to regulate correctly.

Table 14 Parameterization of the TopCon master

3.5.3. Parameter settings for linear post-processing unit

The controller parameters in both the TopCon power supply and the TC.LIN linear post-processing unit can be conveniently set in the TopControl PC software.

To set the controller parameters for TC.LIN, in the "Target" field ((1) in Fig.) the entry "TCLIN <ID=0>" must be selected instead of "System controller". When using more than one TC.LIN only in parallel mode, the device to be set-up is chosen (the example shows parameterization of the TC.LIN with ID=7).

It is strongly advised to use the same parameters for all devices of the same kind and to differ from this rule only in exceptional cases.

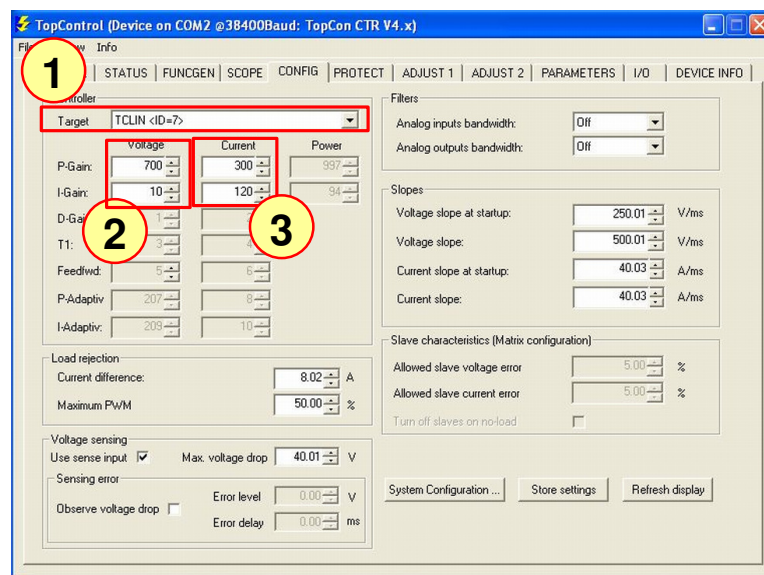

Fig. 26 Configuration window for TC.LIN

Grp	Field	Values	Description
1	Target	TCLIN <ID=0> ¹⁾	Selects the fields below for setting the controller in the linear post-processing unit
2	Voltage	Default values: P = 700 I = 10	Proportional- and Integral part of the voltage controller ³⁾
3	Current	²⁾	Proportional and integral portion of the controller parameters ⁴⁾

- 1) ID = CAN address here =0.
- 2) Examples for controller settings in the TC.LIN are given in Table 16.
- 3) The default values are implemented in TC.LIN firmware (from DSP firmware v0.18 upwards) as preset and will thus be used, if an incompatible version of TopControl is used.
- 4) These values are set identically for all TC_LIN operated at the same time.

Table 15 Controller parameterization of the TC.LIN

3.5.4. Notes on setting the controller parameters for the TC.LIN

These rules apply independent of the application. Application-dependent rules for the photovoltaic domain (solar array simulation) are given in the following section.



- "Rules of thumb"**
- P-Gain can be set to 2 - 6 times of the I-Gain
 - In applications that are primarily operated with smaller currents in relation to I_{nom} , the controller gains can be selected higher.
 - The P-Gain of the voltage can be set to: $400 < P_{gainV} < 2000$
 - The I-Gain of the voltage can be set to: $I_{gainV} < 16$

Along with the general parameters, further settings are to be made depending on the application (see below).

3.5.5. Special controller parameters: Solar Array Simulation

This section provides information on the parameterization of the TC.P / TC.LIN master/slave system for operation as a solar array simulator with solar inverters.



- "Rules of thumb"**
- The general rules in Section 3.5.4 are to be followed.
 - Excessively low controller parameters (I-Gain < 30) will have a negative effect on the dynamic performance such that, e.g., inverters with 100Hz MPP tracking algorithms could become inaccurate. As a rule this problem is due to the phase shift.
 - Inverters with MPP trackers that make large jumps (e.g. to be able to leave local maxima) generate as a result a large current ripple. As a rule they therefore require a slower setting (see Table 16).

Scenario (inverter type)		Current controller		Control characteristic
#	Properties	P-Gain	I-Gain	

1	Low input capacitance (approx. 300uF) Single stage layout	100..1000	30..250	"Slow" controller settings
2	High input capacitance (approx. 1mF) Single stage layout	1000	500	"Fast" controller settings
3	Low input capacitance (approx. 2x300uF); two-stage layout (e.g. with booster)	100..1000	30..250	"Slow" controller settings

Table 16 Examples for modified controller settings on the TC.LIN

3.5.6. Switching of the used current range

3.5.6.1. Background: Increasing of the accuracy by using the alternative current range

It is useful to switch the current range to half the nominal current (alternative current range) if you want to increase the accuracy of the measurements in the case of the operation of inverters with low currents. For instance the resolution of 14.5 bits (0.05%) is not utilised at 40A (corresponds to 0.02A) but at 20A (0.01A). As a result the operation of the TC.LIN in this half range of current will double the absolute measuring accuracy.

The switch from the so-called "full mode" to the "half mode" (alternative setting) and back can be triggered for all TC.LIN device at the same time by using the software TopControl.

If separate settings for the various TC.LIN devices are to be used, those variables must be set "manually" (in the register card "PARAMETERS"). This step requires the TopCon device to be linked to the TC.LIN that is to be manipulated (cf. Fig. 24).



3.5.6.2. Switching the current range using TopControl software

From TopControl version 4.01.60 upwards switching the used current range in all linked TC.LIN can be conveniently achieved by using the related TopControl functionality. For this the PC has to be connected to the TopCon (!) master device (cf. Fig. 23).

3.5.6.3. Switching the current range using direct parameter modification

Switching of the current range of the TC.LIN per parameter modification (see section 3.5.6.2 for ordinary procedure) is necessary only in those cases where the different TC.LIN modules of a single system should be configured unequally.

To set the current range manually, two parameters must be modified. A third parameter then returns the actual current range in use.

Preparation

For this modification TopControl must be switched to the "Power User" mode. This requires to have the "single-day password".

→ Refer to Regatron / TopCon support and note the password for later use.

Procedure

- Connect PC and start TopControl:
Connect the PC directly to the TC.LIN device via the RS-232 interface (see notes in Section 3.4.6, p. 31).
- Change to the user level "Power User" (if not already done):
if the "PARAMETERS" tab is not available, then you must change to the user level "Power User" using [menu: Window][menu command: Preferences...]. For this you will need the "single-day password" (see also manual for TopCon power supply, to be requested from Regatron AG - TopCon support).
- Read gridfile:
[Tab: Parameters] [gridfile>] [load gridfile...]; select and load the .gr3 file there.
(The gridfile contains the coded relation between the variables with the internal addresses. Please refer to the TopCon support for receiving the necessary gridfile.)
- Set parameters:
Set the parameter "AlternateNominalCurrentEnabled" with a value from Table 17.
- Write parameters to the TopCon:
click on [Write]
- Copy new parameters permanently in the device:
Click on button [CopyEEToFlash] (located under of button "Verify", only in newest version of TopControl!)
- Switch off device
- Switch device on again after approx. 20 s and reconnect TopControl with the device ([menu: File] [Connect...])
- The parameter "DeviceNominalCurrentUsed" should now indicate the new current range actually used (see Fig. 27, last row), physical presentation unit is Amps

Current range			Parameter
TC.LIN.SER 13/26	TC.LIN.SER 20/40	TC.LIN.SER 22/45	"AlternateNominal-CurrentEnabled"
0 – 13A	0 – 20A	0 – 22A	1
0 – 26A	0 – 40A	0 – 45A	0

Table 17 Parameters necessary for manual range switching

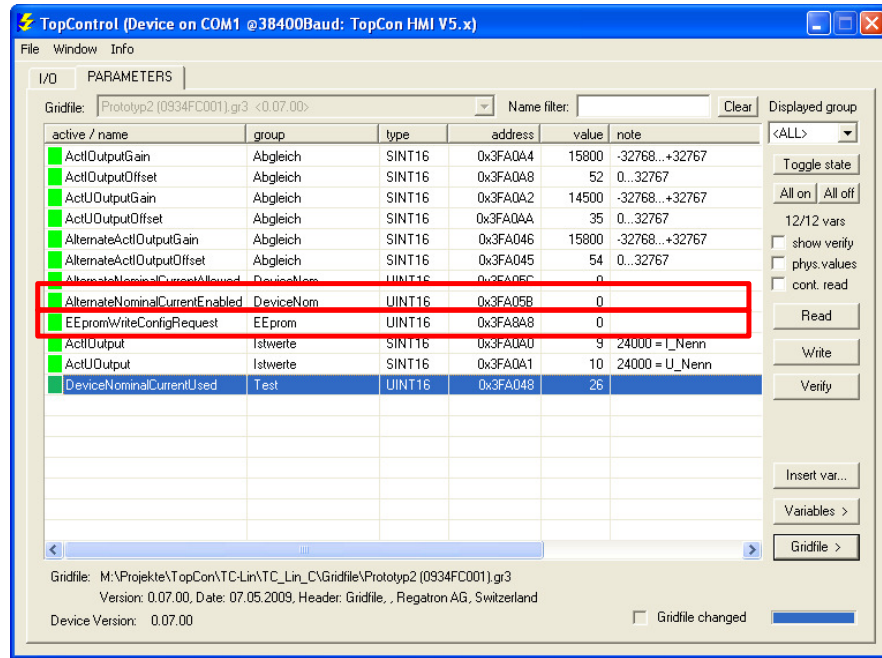

Fig. 27 Parameter list for (manual) range switching using parameters

3.5.7. Storing / Reloading a TC.LIN system configuration

A system configuration consists of a set of parameters the belong to the TopCon power supply device as well as to the TC.LIN device.

A function to store and load a user definable system configuration is available from TopControl v4.01.64 upwards.

The following pictures (Fig. 28 and Fig. 29) depict along the first version how to export those configuration parameters that are relevant for use with TC.LIN devices to a file and how to reload them.

It is strongly recommended to save the current parameter set prior to modification of the controller parameter or when other config [tab: CONFIG] or protect [tab: PROTECT] parameters are changed.



Fig. 28 Using TopControl to save/load config and protect parameters

The related dialog (store or restore) is opened from the menu:



Fig. 29 Minimum configuration to store the TC.LIN settings to a file

In the now opening dialog window (cf. Fig. 29), selecting the TC.LIN checkbox is sufficient to store all parameters that are related to the TC.LIN modules being connected to the TopCon system. The evoked file select dialog defines where to store (or from where to load) the file containing the parameters.

Loading a set of parameters is done in the same way.

3.6. Maintenance

3.6.1. Maintenance of the hardware

In principle the hardware is maintenance-free. The statements in the operating instructions for the TopCon power supply on hardware maintenance also apply as appropriate to the TC.LIN linear post-processing unit. They relate, among other issues, to the service life of the fans.

Fans and cooler are in particular to be checked periodically dependent on the application conditions (dirt, dust) and cleaned, if necessary.

3.6.2. Maintenance of the software

The TopControl PC software does require any special maintenance. An update to the latest version may, however, provide new or improved functionality. You can obtain the latest version from Regatron AG.

3.6.3. Calibration: adjusting the controller parameters

(see Sections 3.4.7 and 3.5.4)

The TC.LIN linear post-processing unit is supplied with typical parameter values set as defaults. The correct function of the load connected (e.g. inverter) can be degraded by these default parameter settings.

Therefore, prior to using the system the optimum parameters must be found and set.



3.6.4. Warnings, errors and troubleshooting

On the TC.LIN: error detection and troubleshooting

The errors that occur during operation are saved in the TopCon power supply and set the device in an error state with safe shut down. In addition, for some physical variables (e.g. temperature of components) there are warning thresholds that trigger the warning state in the system if exceeded. In this case the system remains fully functional. A warning does not need to be cleared manually. As a rule a warning state of extended duration will, however, set the device in the error state.

On the TopCon power supply (with HMI): error detection and troubleshooting

TopCon power supplies equipped with the Human Machine Interface (HMI) indicate the system state in the status bar (cf. Fig. / left: Error). A short explanation of the error is given in the message bar (second line).

The error is analysed with the aid of the error (warning) groups stated using the list given in Section 0.

On the HMI main menu, the list of errors / warnings present can be viewed using the command [Error group] or [Warning Group]. From HMI version v5.11.00 more detailed error messages are also displayed in the HMI.

[ESC] key clears the error state.

Version

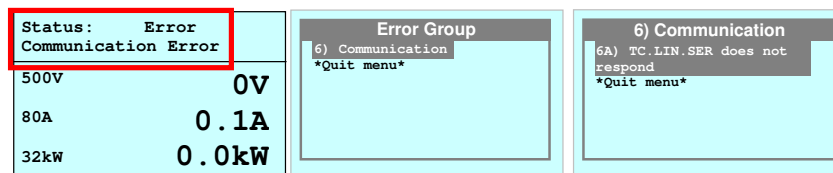

Fig. 30 Indication of the error state (left) and the error information (right)

On the TC.P with TopControl: error detection and troubleshooting

The most convenient way to obtain information on the error that has occurred is to use the TopControl PC software.

Information on errors can be obtained on the CONTROL tab (start page), also on those in the linear post-processing unit (TC.LIN), in two ways:

- By reading the actual error directly ("Show Error detail", see Fig.)
- By the displaying the entire error history ("Error history", see Fig.)

It can take a few seconds to read the entire error history.

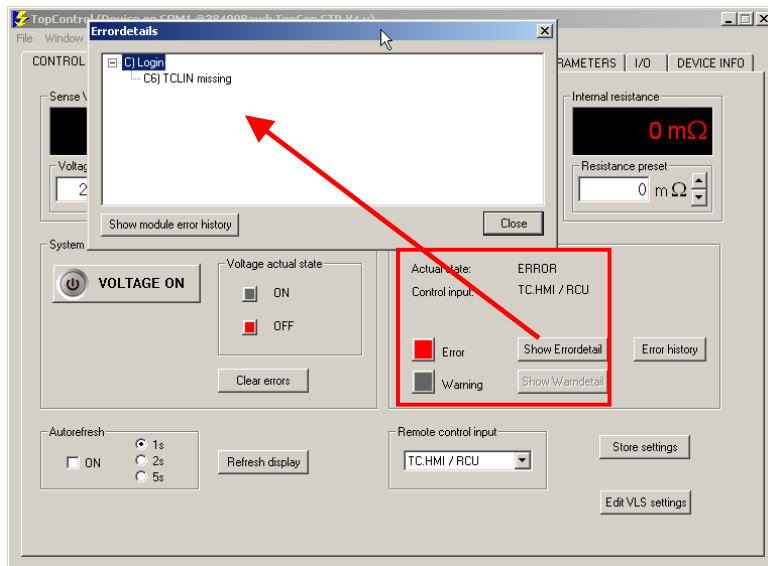

Fig. 31 Reading the error description directly in TopControl

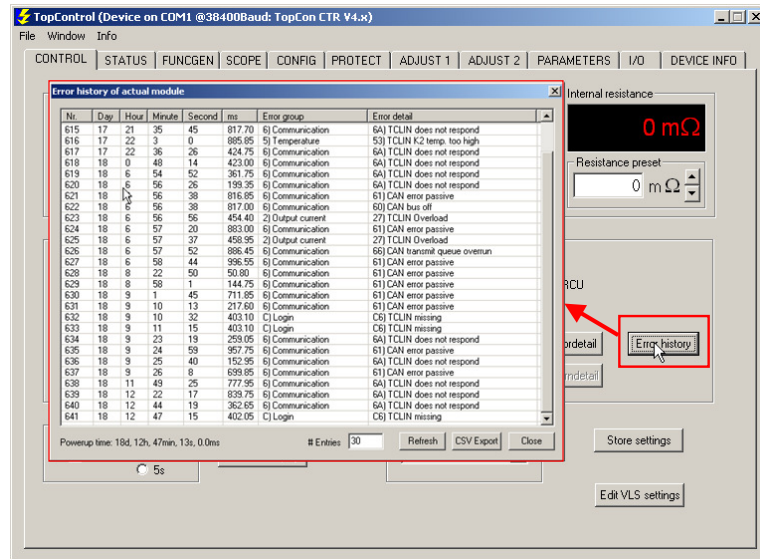

Fig. 32 Display of the error history (only possible in TopControl)

3.6.5. Error and warning codes for the TC.LIN

The indication is provided by a flashing code [LED: Error] on the front of the TopCon power supply, however also via the HMI or in TopControl in plain text.

In the linear post-processing unit and in the TC.P master the following errors / sources of errors are identified.

Flashing code	Indication TopControl / HMI	Description	Possible cause → Measure to rectify
Group error: 2) Output current			
3-7	26) TCLIN Overcurrent	Current exceeds permitted limit	→ Reduce load
3-8	27) TCLIN Overload	Safe Operating Area limit (SOA) exceeded, excessively high transients have occurred	Controller is unstable → Reduce gain → Reduce drop voltage
Group error: 3) Output voltage			
4-3	32) TCLIN Overvoltage	Voltage exceeds limit	Controller is unstable → Reduce gain → Reduce drop voltage → Reduce input voltage
Group error: 4) Supply voltage			
5-1	40) TCLIN +5V too high	Supply voltage exceeds/is below permitted limits	-) Internal power supply faulty -) Other error on board → Re-start, if necessary contact Regatron AG support
5-2	41) TCLIN +5V too low		
5-15	4E) TCLIN +15V too high		
5-16	4F) TCLIN +15V too low		
Group error: 5)			
6-3	52) TCLIN K1 temperature too high	Heat sink temperature at measuring point K1 or K2 too high	-) Cooling is not operating satisfactorily, dust → Check air inlet/outlet?, fans ok?
6-4	53) TCLIN K2 temperature too high		
6-5	54) TCLIN PCB temperature too high	Temperature on the circuit board too high	-) Power loss excessive → Reduce drop voltage -) PCB has cable break, other fault → Contact support
Group error: 6)			
7-1	60) CAN bus off	CAN controller error	(See TopCon operating instructions)
7-2	61) CAN error passive	CAN controller error	
7-7	66) CAN transmit queue overrun	(Internal conflict)	
7-11	6A) TC.LIN does not respond	The communication between TopCon master and TCLIN has been interrupted, but	Connector on the CAN cable is loose. → Connect cable and

		was working before.	fasten, re-start system.
7-12	6B) TCLIN CAN error	General error on the CAN interface	→ Check cabling, follow power-on sequence, re-start system, if necessary contact support
Group error: C) Login			
13-5	C4) TCLIN CAN protocol version is not identical	Master and TCLIN cannot communicate	TCLIN has a different CAN version to the master → Update TC.LIN or TC.P master
13-7	C6) TCLIN missing	The TopCon master is not finding a TCLIN on system start / cannot establish a connection	TC. P master cannot start connection. → Re-start: Do not switch on TC.LIN after TC.P (see Sec. 3.4.2, p. 27) → Check CAN cable
Group error: D) Configuration			
14-15	DE) TCLIN ID invalid	Master detecting invalid TCLIN ID	→ Check IDs for the TCLIN (ID= 0..7) individually / set
14-16	DF) TCLIN ID not unique	Master detecting several TCLIN with same ID	→ Check IDs for the TCLIN individually / set
This list is not final and will be expanded with further development. E.g., cable break detection is in preparation.			

Table 18 TC.LIN error messages and error codes

4. Various other notes

4.1. Emission of noise, gas, radiation

Noise

During the operation of the TC.LIN electrical energy is converted into heat. This heat is dissipated at the rear of the device by forced cooling. The fans operate at varying speeds depending on the power to be dissipated and cause corresponding noise. To prevent harm to health, hearing protection may need to be worn.

The characteristic of the fan speed is optimised on delivery, however, it can be further modified (see Section 3.1.6).

In addition the voltage V_{drop} can be reduced which will result in the need to dissipate less energy in the form of heat.

Gas

The emission of gas is not to be expected and can be ignored.

Radiation

The emission of radiation is not to be expected and can be ignored.

4.2. Storage and protection during breaks in usage

If the device is not to be used for an extended period (e.g. a few weeks), protected intermediate storage is required. For this purpose the original packaging should be used.

All connections to the device are to be disconnected. The front and rear are to be protected against damage. The device is to be stored in a dry place with a normal temperature. Particular attention is to be paid to ensuring no condensation is formed.

4.3. Returning the device

The device should only be returned to the manufacturer after prior consultation with the distributor or the manufacturer.

In this case the user must ensure that the device cannot be damaged during transport. In particular, the controls and connections on the front and rear are to be protected against transport damage. The original packaging should be used.

4.4. Disposal

If the device is to be disposed of, the related national laws and return systems for waste industrial equipment apply. In case of doubt, contact the manufacturer.

The device should be returned to the manufacturer in the original packaging; the packaging will then also be disposed of.

5. Appendix

5.1. Overvoltage protection for firmware prior to version v0.18

As long as no voltage controller has been implemented in the firmware of the TC.LIN (= up to version v0.17) it is recommended to use a voltage limiting characteristic together with the PV curve (AAP curve).

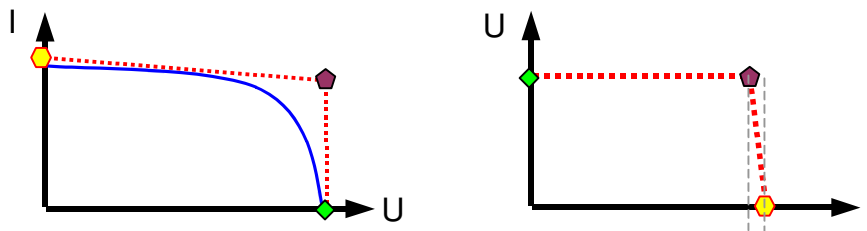

Fig. 33 Principle of the curve based overvoltage protection
(Overview together with SAS characteristics (left), exact shape (right))

Rule of thumb for determination of the defining curve points

Diamond, green $I = 0A$, $U = U_{oc}$

Pentagon, red $I = I_{sc}$, $U = U_{oc}$

Hexagon, yellow $I = I_{sc} + \Delta$, $U = 0V$

Delta is a small value > 0 , that prevents the pentagon and the hexagon to have an identical current value (unclear function definition).

Example: $I_{sc} = 10A$, $I_{sc} + \Delta = 10.1A$

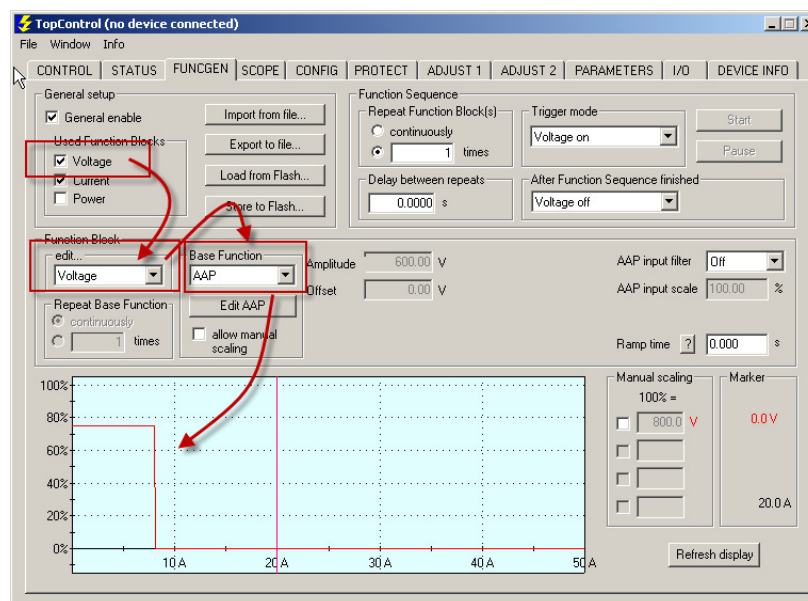

Fig. 34 Procedure to create the overvoltage protection characteristics

5.2. Calibration: voltage and current range measurement

Note: The device is calibrated in the factory. Normally re-adjustment is not necessary.

For all calibration work the post-processing unit must be connected directly to the PC via the RS-232 interface.

Procedure:

- Open the [Parameters] tab
- Select the gridfile (from drop-down list) or
- If necessary load the file using the [Gridfile>][Load gridfile...] button
- Reduce the entries displayed using [Name filter] or [Displayed Group].
- Activate the variable (=light green symbol in column 1) by double-clicking with the right mouse button. The variables that may need to be adjusted are listed in Table 19.
- Double-clicking with the left mouse button will open the window for editing the entry
- Using [Write] write the variable with the green marking to the device.
- After finishing the parameter modification, press [CopyEEToFlash] button
- Switch off device and switch on again.

Further explanations on the [Parameters] tab are given in the operating instructions for the TopCon power supply.

Variable list for adjustment/calibration process:

Note: The two current ranges (full or half range of current) can be calibrated completely independently of each another.

Variable name	Phys. variable	Function / significance
Display group: "Abgleich"		
ActIOutputOffset	Offset	Adjustment of the values for the full current range
ActIOutputGain	Gain	
AlternateActIOutputOffset	Offset	Adjustment of the current range indication (offset / gain) for the alternative range of current
AlternateActIOutputGain	Gain	
ActUOutputOffset	Offset	Adjustment of the measured values for the actual output voltage
ActUOutputGain	Gain	
NominalShuntTemperature	(Offset) 4000 = 25°C	Adjustment of the temperature shift for the shunt resistor
ShuntTemperatureKoeff	Delta / Temp in ppm / K	
Display group: "Istwerte"		
ActIOutput	Actual current	Adjustment of the actual value for current, voltage
ActUOutput	Actual voltage	

Table 19 Variable list for adjustment and calibration

6. Index

AAP characteristic	
Operation, procedure	29
Accuracy	
alternative current range	38
Block diagram	10
CAN bus	
with multi device system	25
with TopCon/TC.LIN combination	22
Characteristic data	
Control	14
Power interface	14
Protection function	15
Commissioning	21
Control	11
current control	11
Principle	9
Principle of operation	11
voltage controller	11
Controller parameterization	
General notes	36
TC.LIN	36
TOPCon parameters	34
Cooling	15
Current	
Control range / characteristic	9
Current range	
by direct parameter modification	38
full vs. alternative (half)	10
half / full	10
Switching	38
using TopControl	38
Dimensions	20
Disposal	46
Electrical installation	21
Error	42
Error codes (list)	44
Glossary	8
HMI	
Troubleshooting	42
Interface	
Analogue and digital I/O (X105A)	18
Internal CAN bus (X101/2)	17
Serial (RS-232, X100)	16
Signals analogue/ digital (X105A)	23
Interlock	23
Intermediate storage	46
Limits	
of use	12
Maintenance	41
Master/slave system	24
matrix wiring	24
Model range	10
Noise	46
Operation	
Getting started	27
Overview	9
Parameterization	
Overview	11
Performance	
Control range / characteristic	9
Pictogram	7
Power	
preset	32
Preset power	32
Preset voltage	31, 32
Protection functions	15
Radiation	46
Resolution	
Response time	14
Returning to manufacturer	46
Sense	23
Start-up process	27
internal view	33
Storage	46
Switch-on procedure	
Internal process	31
TC.LIN	
Basic device	13
Circuit (typical)	21
Controller parameterization	36
Dimensions	20
Front view	13
Master/slave system	24
Rear view	13
TopControl	
Troubleshooting	42
Voltage	
Control range / characteristic	9
Preset	32
Voltage control	
Overview	11
Voltage Control	
Loading settings	40
Parameter, rules of thumb	37

Storing settings40
Values in TopCon35

Warning 42