

Differential Pressure Transducers

Model 8310
Models 8313, 8314
Models 8315, 8316

Code:	8310 EN
Delivery:	10 - 12 weeks
Warranty:	24 months

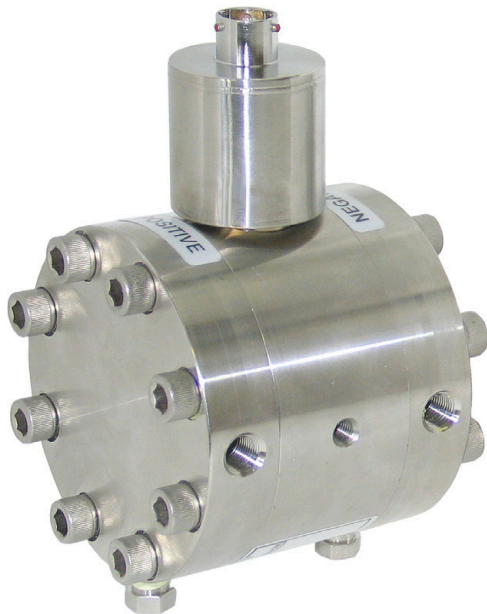

Model 8310
for lower pressure ranges



Models 8313, 8314
for medium pressure ranges



Models 8315, 8316
for high pressure ranges

- Measuring ranges from 0 ... ± 35 mbar to 0 ... ± 500 bar
- Accuracy < 0.25% or < 0.5%
- Available for line pressures up to 345 bar
- Output available as ± 5 V or 4 ... 20 mA
- Suitable for liquid or gaseous media
- Made of stainless steel, reliable, robust

Application

The here presented pressure transducers measure differences in pressure between the two connections of the measuring element. Pressure differences can be measured with respect to a reference pressure, such as atmospheric, or to the command variable of a regulation system. Equally, however, it is possible to measure pressure differences within systems that have a high static pressure. One practical example of this would be measuring a flow rate by measuring the pressure drop occurring across a metering diaphragm.

The differential pressure transducers react in both directions - as are found, for instance, on double-acting hydraulic cylinders in material testing machines - and can handle liquid or gaseous media on both ports. Venting holes simplify practical application. The robust design and the use of stainless steel make it possible to use the differential pressure transducer under tough operating conditions.

Description

On both pressure ports, the differential pressure transducers include a closed chamber, each with a membrane. Both membranes, like all the parts that come into contact with the medium, are made of stainless steel and are welded to create a hermetic seal against the inner space of the measuring element. Transducers with this structure are also referred to as wet/wet; it allows differential pressure of gaseous and liquid media to be measured directly. The here presented differential pressure transducers show another interesting feature: they operate bidirectionally. In other words, it does not matter to which port the higher pressure is connected.

The physical magnitude of the pressure is converted into an electrical magnitude by means of an integrated Wheatstone bridge circuit, consisting of four foil strain gauges. Integrated measurement amplifiers for ± 5 V or 4 ... 20 mA are offered as an option; this increases the height by 29 mm.

Technical Data - Model 8310

Model	Order Code	Measurement Range	Typ. Measurement Error* [% F.S.]	Characteristic Nominal [mV/V]
8310	8310-35	0 ... ± 35 mbar	< ± 0.25	1
	8310-100	0 ... ± 100 mbar	< ± 0.25	1.5
	8310-200	0 ... ± 200 mbar	< ± 0.25	2
	8310-500	0 ... ± 500 mbar	< ± 0.25	2
	8310-1000	0 ... ± 1000 mbar	< ± 0.25	2
	8310-2000	0 ... ± 2000 mbar	< ± 0.25	2

* Total error consisting of non-linearity, hysteresis and variation.

Electrical values

Bridge resistance: foil strain gauge 350 Ω, nominal
 Calibration shunt resistor: 59 kΩ ± 0.1 %
 The bridge output voltage, caused by a shunt resistor of this value is given in the calibration protocol.
 Excitation voltage: 10 V DC or AC
 Sensitivity: refer to table
 Insulation resistance: 5 GΩ at 50 V DC

Environmental conditions

Operating temperature: 0 °C ...90 °C
 Nominal temperature range: 0 °C ...55 °C
 Influence of temperature to zero signal: < ± 0.5 % F.S./55 K
 Influence of temperature to characteristic: < ± 0.5 % Rdg./55 K

Mechanical values

Kind of measurement: measurement of differential pressure
 Dead volume: every side approx. 6.6 cm³
 Variation of volume: for range 0 ... ± 200 mbar approx. 0.17 cm³
 Pressure of system¹⁾: max. 100 bar
 Influence of system pressure to zero signal: < ± 0.5 % F.S./70 bar
 Overload²⁾: one side max. 100 bar
 Resonance frequency:
 for range 0 ... ± 200 mbar liquid media 5 Hz
 gaseous media 10 Hz
 Dynamic load:
 recommended 70 % of nominal pressure
 possible 100 % of nominal pressure

Design:

Both pressure chambers are sealed hermetically, the membranes are welded. The outer caps of the pressure chamber are bolt. They are sealed by O-rings, made of VITON®.

All differential pressure transducers used for low pressure ranges contain silicone oil between their membranes. Due to this their maximum operation and storage temperature is 90 °C

Material: stainless steel 316SS (like 1.4571)

Pressure connection: internal thread 1/8 - 27 NPT

Bleeder holes: closed at delivery internal thread 1/8 - 27 NPT

Electrical connection: 6 pin bajonett lock, Amphenol 62GB-16F-10-6S

Wiring (standard):

pin A + B	excitation voltage	positive
pin C + D	excitation voltage	negative
pin E	signal output	negative
pin F	signal output	positive

Mating connector: model 9945
 Amphenol 62GB-16F-10-6S or Souriau 851-06E-C-10-6S in scope of delivery

Dimensions: refer to dimensional drawing

Mounting:

Mounting hole with internal thread 1/4-28 UNF, 8 mm deep on both sides of the differential pressure transducer.

Weight: approx. 3.8 kg

Dimensional drawing model 8310

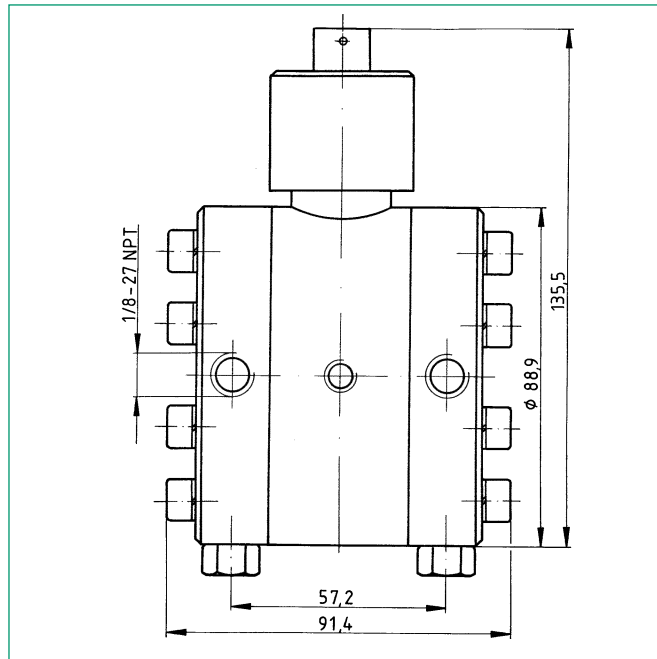

¹⁾ The differential pressure transducers for low pressure ranges may be used to take measurements on systems with line pressures up to 100 bar (or, with the option, up to 345 bar). The line pressure is the maximum static pressure that is permitted simultaneously on both ports of a differential pressure transducer. The result of adding the static pressure to the pressure to be measured must also not exceed the maximum line pressure. For instance, a transducer with a measuring range of 0 ... ± 100 mbar may be exposed to 100 bar at one pressure port and 99.9 bar at the other, or may have 0 bar at one port and 0.1 bar at the other. It should be noted that when the line pressure changes, the zero point moves. The shift in the zero point is reproducible. It is normal and is compensated for a line pressure of 100 bar.

²⁾ All the differential pressure transducers have mechanical protection against overload. If the measuring range is exceeded by more than 50%, the membrane presses against a stop. Because this stop places a heavy mechanical stress on the membrane, overload should be avoided entirely if at all possible. If, however, overloading does occur, the zero point will move; a change in precision or damage is prevented. Damage will only be caused by frequent or sudden overload.

Order Code

Refer to table, additionally please mention options with short terms.

Test and Calibration Certificate

Included in delivery, et al. with specification of zero output, sensitivity and shunt calibration factor.

Options

Internal amplifier with voltage output - 5 V...+ 5 V DC **...-V2xxxxxx**
 technical data refer to data sheet 83-IMV

Internal amplifier with current output 4...20 mA;
 $\Delta p \triangleq 0 \text{ bar} = 4 \text{ mA}$, $\Delta p = \text{full scale positive} \triangleq 20 \text{ mA}$ **...-V4xxxxxx**
 technical data refer to data sheet 83-IMV

Extension of max. pressure of system to 200 bar;
 maximum overload for one side: 100 bar **...-Vxx1xxxx**

Extension of max. pressure of system to 345 bar;
 maximum overload for one side: 100 bar,
 only available for range > 0 ... ± 500 mbar **...-Vxx2xxxx**

Factory Calibration Certificate (WKS)

Calibration of a pressure transducer separately as well as connected to an indicator. Standard is a certificate with 11 points, starting at zero, running up and down in 20% increments and covering the complete measuring range. Special calibrations on request. Calculation of costs by base price plus additional costs per point.

Order Code 83WKS-83...

Technical Data - Models 8313, 8314

Model	Order Code	Measurement Range	Typical Measurement Error* [% F.S.]
8313	8313-5	0 ... ± 5 bar	< ± 0.25
	8313-10	0 ... ± 10 bar	< ± 0.25
	8313-20	0 ... ± 20 bar	< ± 0.25
	8313-50	0 ... ± 50 bar	< ± 0.25
8314	8314-5	0 ... ± 5 bar	< ± 0.50
	8314-10	0 ... ± 10 bar	< ± 0.50
	8314-20	0 ... ± 20 bar	< ± 0.50
	8314-50	0 ... ± 50 bar	< ± 0.50

* Total error consisting of non-linearity, hysteresis and variation.

Electrical values

Bridge resistance:	foil strain gauge	350 Ω, nominal
Calibration shunt resistor:		59 kΩ ± 0.1 %
The bridge output voltage, caused by a shunt resistor of this value, is given in the calibration protocol.		
Excitation voltage:	recommended possible	10 V DC or AC 15 V DC or AC
Characteristic:		2 mV/V, nominal

Environmental conditions

Range of operation temperature:	- 55 °C ... 120 °C
Range of nominal temperature:	15 °C ... 70 °C
Influence of temperature to zero signal:	
model 8313	< ± 0.5 % F.S./55 K
model 8314	< ± 0.75 % F.S./55 K
Influence of temperature to characteristic:	
model 8313	< ± 0.5 % Rdg./55 K
model 8314	< ± 1.0 % Rdg./55 K

Mechanical values

Kind of measurement:	measurement of differential pressure		
Individual error:			
model 8313	non-linearity	< ± 0.15 % F.S.	
	hysteresis	< ± 0.10 % F.S.	
	variation	< ± 0.05 % F.S.	
model 8314	non-linearity	< ± 0.25 % F.S.	
	hysteresis	< ± 0.13 % F.S.	
	variation	< ± 0.07 % F.S.	
Dead volume:	every side approx.	4.1 cm ³	
Variation of volume:	for range 0 ... ± 20 bar	approx.	0.1 cm ³
Pressure of system:	maximum		100 bar
Maximum overload for one side:			100 bar
Natural frequency:			
for range	0 ... ± 20 bar	liquid media	10 Hz
		gaseous media	20 Hz
Dynamic load:			
recommended possible		70 % of nominal pressure	
possible		100 % of nominal pressure	
Design:	Both pressure chambers are sealed hermetically, the membranes are welded. The outer caps of the pressure chamber are bolt. They are sealed by O-rings, made of viton.		
Mounting:	Mounting hole with internal thread 1/4-28 UNF, 8 mm deep, central on both sides of the differential pressure transducer.		
Material:	stainless steel 17 - 4 PH, like	1.4542	
Pressure connection:	internal thread	1/8 - 27 NPT	
Bleeder holes:	closed at delivery	internal thread	1/8 - 27 NPT
Electrical connection:	6-pin bajonet lock	Souriau 851-07A-10-5P	

Dimensional drawing models 8313 and 8314

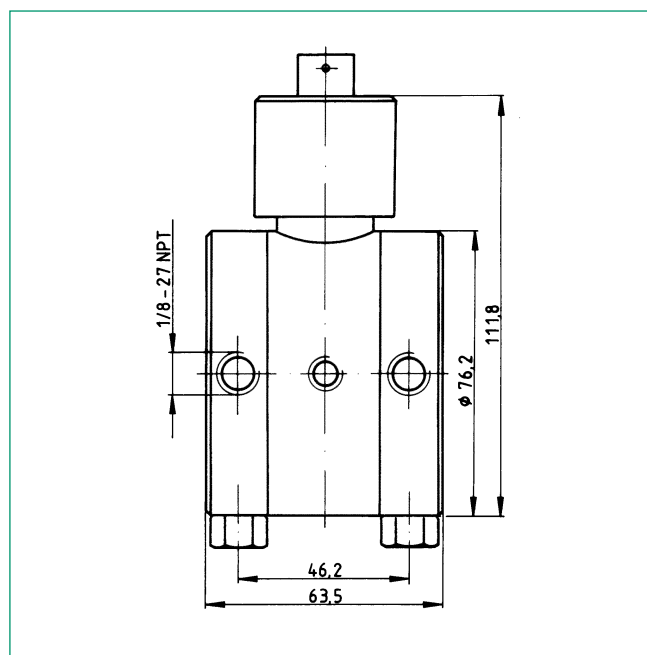

The differential pressure transducer for medium pressure ranges can be used to take measurements on systems up to a line pressure of 100 bar. The line pressure is the maximum static pressure that is permitted simultaneously on both ports of a differential pressure sensor. The result of adding the static pressure to the pressure to be measured must also not exceed the maximum line pressure. For instance, a transducer with a measuring range of ± 10 bar may be exposed to 100 bar at one pressure port and 90 bar at the other, or may have 0 bar at one port and 10 bar at the other. It should be noted that when the line pressure changes, the zero point moves. The shift in the zero point is reproducible. It is normal and is compensated for a line pressure of 100 bar.

Wiring:			
pin A + B	excitation voltage	positive	
pin C + D	excitation voltage	negative	
pin E	signal output	negative	
pin F	signal output	positive	
Mating connector:		model 9945	
	Amphenol 62GB-16F-10-6S or Souriau 851-06 E-C-10-6S	in scope of delivery	
Dimensions:		refer to dimensional drawing	
Weight:		approx.	2.3 kg

Order Code

Refer to table, additionally please mention options with short terms.

Test and Calibration Certificate

Included in delivery, et al. with specification of zero output, sensitivity and shunt calibration factor.

Options

Internal amplifier with voltage output - 5 V...+ 5 V DC	...-V2xxxxxx
technical data refer to data sheet 83-IMV	
Internal amplifier with current output 4...20 mA;	
Δp ≙ 0 bar = 4 mA, Δp = full scale positive ≙ 20 mA	...-V4xxxxxx
technical data refer to data sheet 83-IMV	
Extension of max. pressure of system to 200 bar;	
maximum overload for one side: 100 bar	...-Vxx1xxxx
Extension of max. pressure of system to 345 bar;	
maximum overload for one side: 100 bar,	
only available for range > 0 ... ± 500 mbar	...-Vxx2xxxx

Factory Calibration Certificate (WKS)

Calibration of a pressure transducer separately as well as connected to an indicator. Standard is a certificate with 11 points, starting at zero, running up and down in 20% increments and covering the complete measuring range. Special calibrations on request. Calculation of costs by base price plus additional costs per point.

Order Code 83WKS-83...

Technical Data - Models 8315, 8316

* Total error consisting of non-linearity, hysteresis and variation.

Model	Order Code	Measurement Range	Measurement Error [% v.E.]	Max. System Pressure [bar]	Max. Overload to One Side [bar]
8315	8315-100	0 ... ± 100 bar	< ±0.25	240	200
	8315-200	0 ... ± 200 bar	< ±0.25	340	400
	8315-500	0 ... ± 500 bar	< ±0.25	640	750
8316	8316-100	0 ... ± 100 bar	< ±0.5	240	200
	8316-200	0 ... ± 200 bar	< ±0.5	340	400
	8316-500	0 ... ± 500 bar	< ±0.5	640	750

Electrical values

Bridge resistance: foil strain gauge 350 Ω , nominal
 Calibration shunt resistor: 59 Ω ± 0.1 %
 The bridge output voltage, caused by a shunt resistor of this value is given in the calibration protocol.
 Excitation voltage: 10 V DC or AC
 Sensitivity: 2 mV/V, nominal

Environmental conditions

Operating temperature: - 50 °C ... 120 °C
 Nominal temperature range: 15 °C ... 70 °C
 Influence of temperature to zero signal:
 model 8315 ≤ ± 0.5 % F.S./55 K
 model 8316 ≤ ± 0.75 % F.S./55 K
 Influence of temperature to characteristic:
 model 8315 ≤ ± 0.5 % Rdg./55 K
 model 8316 ≤ ± 1.0 % Rdg./55 K

Mechanical values

Kind of measurement: measurement of differential pressure
 Individual error:
 model 8315 non-linearity < ± 0.15 % F.S.
 hysteresis < ± 0.10 % F.S.
 variation < ± 0.05 % F.S.
 model 8316 non-linearity < ± 0.25 % F.S.
 hysteresis < ± 0.13 % F.S.
 variation < ± 0.07 % F.S.
 Dynamic load: recommended 70 % of nominal load
 possible 100 % of nominal load

Design:

Both pressure chambers are sealed hermetically, the membranes are welded. The outer caps of the pressure chamber are bolt. They are sealed by O-rings, made of metal.

Mounting:

One side of the differential pressure transducer, opposite to the connector, has a mounting hole. Internal thread 10 - 32 UNF, 9.5 mm deep.

Material: stainless steel 17-4 PH (similar to 1.4542)
 Pressure connector: internal thread 1/4 - 18 NPT
 Electrical connector: 6 pin bajonett lock Souriau 851 - 07A - 10 - 6P
 Wiring (standard):
 pin A + B excitation voltage positive
 pin C + D excitation voltage negative
 pin E output signal negative
 Stiff F output signal positive

Mating connector: model 9945
 Amphenol 62GB-16F-10-6S or Souriau 851-06E-C-10-6S
 in scope of delivery

Dimensions: refer to dimensional drawing
 Weight: approx. 1.8 kg

Order Code

Refer to table, additionally please mention options with short terms.

Accessories

Connecting cable for sensors with bridge output, complete with coupling plug and socket, 6 core, screened, bending radius > 5 mm, PVC insulation, standard length 3 m
 for any type of burster analysis electronics in desktop housing with 12 pin connection **Model 9911**
 with open, color-coded and tinned cable ends **Model 9986**

Test and Calibration Certificate

Included in delivery, et al. with specification of zero output, sensitivity and shunt calibration factor.

Options

Internal amplifier with voltage output - 5 V...+ 5V DC **...-V2xxxxxx**
 technical data refer to data sheet 83-IMV

Internal amplifier with current output 4...20 mA;
 Δp Δ 0 bar = 4 mA, Δp = full scale positive Δ 20 mA **...-V4xxxxxx**
 technical data refer to data sheet 83-IMV

Dimensional drawing models 8315 and 8316

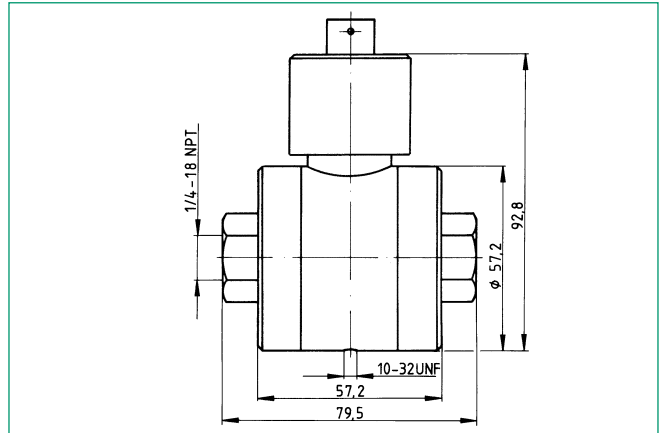

The differential pressure transducers are designed for a line pressure up to 140 bar and are designed for large pressure differences such as occur on double-acting hydraulic cylinders in construction machinery or material test devices. If the measuring range in the positive direction is restricted, the transducers can be used at a higher line pressure - up to the maximum value given in the table.

Thus the sensor that has a measuring range of ± 100 bar, when connected to 0 bar line pressure, operates over the range - 100 ... + 100 bar (figure 1), while when connected to 140 bar line pressure it operates from 40 ... 240 bar (figure 2). If the same sensor is connected to a 240 bar line pressure, only the range from 140 bar ... 240 bar is available for measurements (figure 3).

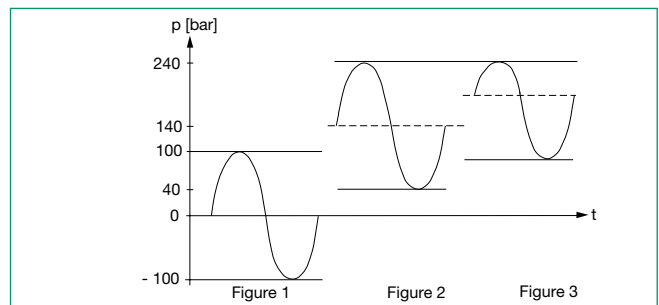

For any applications of the differential pressure sensors, care must be taken to ensure that the value for „overload, one side“ is not exceeded. If the line pressure changes, the sensor's zero point moves. The shift in the zero point is reproducible and is in most cases less than 2% of full-scale. It is normal and is compensated for a static pressure 140 bar on both sides.

Extension of max. pressure of system to 200 bar;
 maximum overload for one side: 100 bar **...-Vxx1xxxx**

Extension of max. pressure of system to 345 bar;
 maximum overload for one side: 100 bar,
 only available for range > 0 ... ± 500 mbar **...-Vxx2xxxx**

Factory Calibration Certificate (WKS)

Calibration of a pressure transducer separately as well as connected to an indicator. Standard is a certificate with 11 points, starting at zero, running up and down in 20% increments and covering the complete measuring range. Special calibrations on request. Calculation of costs by base price plus additional costs per point.

Order Code 83WKS-83...