

Tension Compression Load Cell

Model 8435

Code:	8435 EN
Delivery:	ex stock
Warranty:	24 months

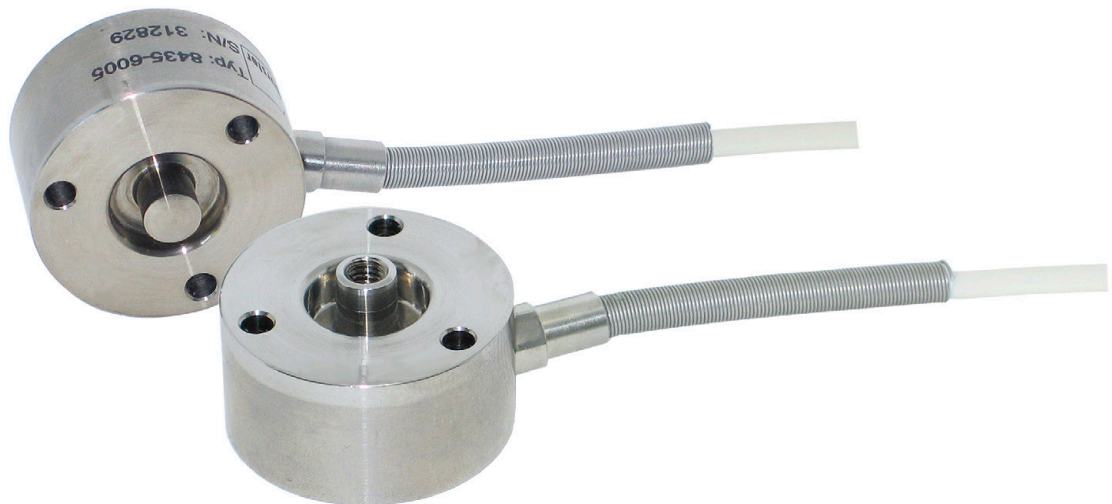

- Measuring ranges from 0 ... 200 N to 0 ... 5000 N
- Small dimensions
- Simple mounting
- Made of stainless steel
- For tension and compression forces

Application

This tension and compression load cell is designed as a compact and universal sensor, which provides a high level of precision at a low price.

Made of stainless steel, the sensor has small dimensions and allows easy assembly in existing structures where static and dynamic forces need to be measured.

This load cell is typically used for measuring forces, weights, coefficients of friction, sliding friction and adhesion on fitting devices, handling gear, coupling mechanisms, loading machines and operating devices.

A load-centering plate is offered as an accessory for simple installation of the load cell in a girder assembly.

Description

This model of load cell uses proven strain gauge technology to perform measurements. Strain gauges are applied to the sensitive element and connected to form a full bridge. The electrical resistance of this full bridge increases with the load acting on it, so that the bridge supplies an output voltage proportional to the measurement variable.

This model allows the force application of two kinds: compression via the load application button and tension via the centric internal thread. The measurement range of 0 ... 5000 N is supplied exclusively with the integrated load application button. The sensor has to be mounted on a level surface using screws fitted through the three bore holes in the outer ring.

To achieve the highest possible measurement accuracy, the sensor should not be subject to lateral forces.

A strain-relief and an anti-bend mechanism for the connection cable are integrated in the sensor housing.

Technical Data

Order Code	Measuring Range	Resonance Frequency [kHz]
8435-5200	0 ... 200 N	5
8435-5500	0 ... 500 N	9
8435-6001	0 ... 1000 N	14
8435-6002	0 ... 2000 N	18
8435-6005	0 ... 5000 N	22

Electrical values

Bridge resistance (full bridge circuit): foil strain gauge 350 Ω, nominal¹⁾

Calibration shunt resistor: 100 kΩ ± 0.1 %

The bridge output signal resulting from a shunt of this value is shown in the calibration certificate.

Excitation: recommended 5 V DC
 measuring range 0 ... 200 N maximum 5 V DC
 measuring range ≥ 0 ... 500 N maximum 10 V DC

Nominal sensitivity: 1 mV/V, nominal¹⁾

Insulation resistance: > 30 MΩ

¹⁾ Deviations from the stated value are possible.

Environmental conditions

Range of operating temperature: - 30 °C ... 80 °C

Nominal temperature range: 15 °C ... 70 °C

Influence of temperature on zero: ≤ ± 0.02 % F.S./K

Influence of temperature on sensitivity: ≤ + 0.03 % Rdg./K

Mechanical values

Non-linearity: < 0.25 % F.S.

Hysteresis: < 0.20 % F.S.

Non-repeatability on unchanged mounting position: < 0.15 % F.S.

Kind of measurement: Tension and compression (calibration in compression direction); measuring range 0 ... 5000 N compression only

Deflection, full scale: approx. 20 μm

Mounting: Three clearance holes with a diameter of 3.2 mm at reference diameter 23.0 mm and division 120°. One hole is across from the cable exit.

Overload safe (static): 150 % of capacity

Overload burst: > 200 % of capacity

Dynamic performance: recommended 50 % of capacity
 maximum 70 % of capacity

Material: stainless steel 1.4542

Electrical termination: shielded, suitable for drag chain 4 leaded TPE isolated cable with open ends for soldering; additional buckling protector and adapter for cable holder; length approx. 2 m, bending radius > 30 mm

Protection class: acc. to EN 60529 IP54

Wiring code: white excitation voltage positive
 brown excitation voltage negative
 yellow signal output positive
 green signal output negative

Dimensions: refer to dimensional drawing

Weight: approx. 40 g without cable

General tolerance of dimensioning: acc. to ISO 2768-f

Order Information

Tension and compression load cell, range 0 ... 500 N
Model 8435 - 5500

Accessories

Load introduction button (not included in scope of delivery) made of stainless steel 1.2842, HRC 60
Model 8580-V004

Pull-plate, material and design as load cell
Model 8590-V001

Mounting of mating connector to conductor cable for preferential usage of the sensor:

In preferential direction (positive signal for compression load)
Order Code: 99004

Only for connection to SENSORMASTER model 9163 desktop version
Order Code: 99002

Against preferential direction (positive signal for tension load)
Order Code: 99007

Only for connection to SENSORMASTER model 9163 desktop version
Order Code: 99008

Evaluation instruments, amplifiers and process controllers refer to section 9 of the catalog.

Technical changes reserved. All data sheets at www.burster.com

Dimensional drawing model 8435

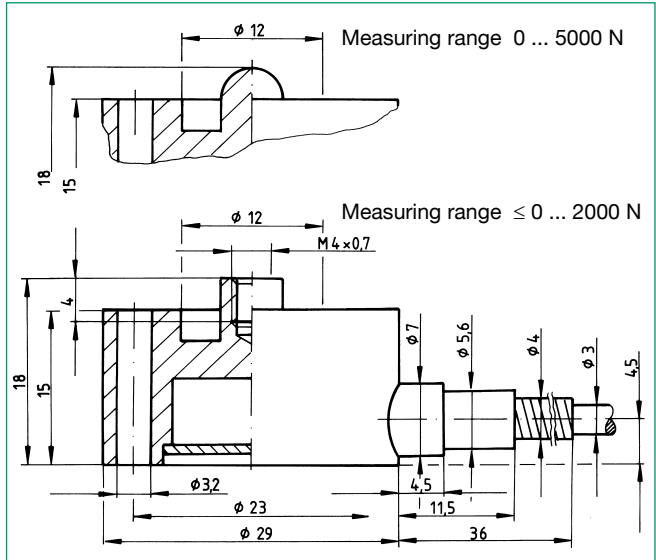

The CAD drawing (3D/2D) for this sensor can be imported online directly into your CAD system.

Download via www.burster.com or directly at www.traceparts.com. For further information about the burster traceparts cooperation refer to data sheet 80-CAD-EN.

Load introduction button model 8580-V004

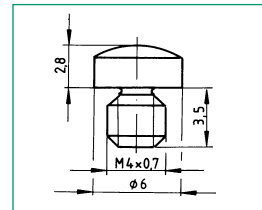

Installation example

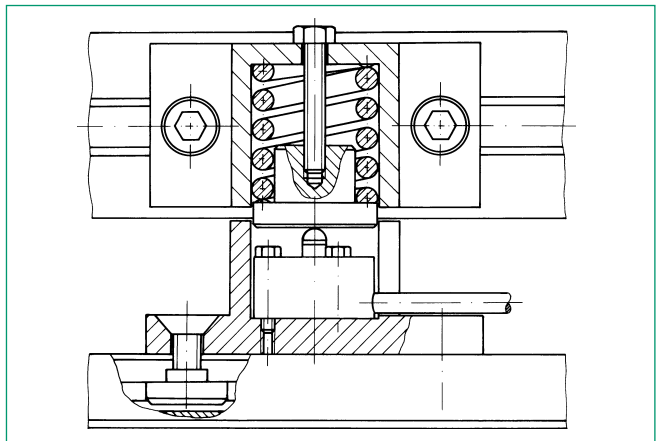

Overload of the load cell is impossible due to a suitable spring. When the units are locked the spring will transfer not more load to the cell than the measuring range can cope with.

Option

Standardization of sensitivity to 0.8 mV/V, done in conductor cable
Order Code: ...-V008

Factory Calibration Certificate (WKS)

Calibration of a load cell separately as well as connected to an indicator. Standard is a certificate with 11 points, starting at zero, running up and down in 20% increments covering the complete measuring range for preferential direction. Special calibrations on request. Calculation of costs by base price plus additional costs per point.

Order Code 84WKS-84...