**User's
Manual**

**701930
Current Probe**

User Registration

YOKOGAWA provides registered users with useful information and services. Please allow us to serve you best by completing the user registration form accessible from our website.

<https://tmi.yokogawa.com/support/>



Contact Us

If you want to resolve a technical support issue or need to contact YOKOGAWA, please fill out the inquiry form on our website.

<https://tmi.yokogawa.com/contact/>



Thank you for purchasing the Current Probe (Model 701930).

This instruction manual contains useful information about the instrument's functions and operating procedures as well as precautions that should be observed during use. To ensure proper use of the instrument, please read this manual thoroughly before beginning operation. After reading the manual, keep it in a convenient location for quick reference whenever a question arises during operation.

List of Manuals

The following manuals are provided for the Current Probe (Model 701930).

Manual Title	Manual Number	Description
701930 Current Probe User's Manual	IM 701930-01E	This manual
701930 Current Probe	IM 701930-92	Document for China
701930 Current Probe	IM 701930-93Z2	Document for Korea
Safety Instruction Manual	IM 00C01C01-01Z1	Safety manual (European languages)

The "E", "Z1" and "Z2" in the manual numbers are the language codes.

Contact information of Yokogawa offices worldwide is provided on the following sheet.

Document Number	Description
PIM 113-01Z2	List of worldwide contacts

Notes

- The contents of this manual are subject to change without prior notice as a result of continuing improvements to the product's performance and functionality. The figures given in this manual may differ from those that actually appear on your product.
- Every effort has been made in the preparation of this manual to ensure the accuracy of its contents. However, should you have any questions or find any errors, please contact your nearest YOKOGAWA dealer.
- Copying or reproducing all or any part of the contents of this manual without the permission of YOKOGAWA is strictly prohibited.

Revisions

- 1st Edition: June 2001
- 2nd Edition: November 2005
- 3rd Edition: October 2013
- 4th Edition: October 2014
- 5th Edition: November 2015
- 6th Edition: January 2016
- 7th Edition: October 2017
- 8th Edition: June 2021
- 9th Edition: December 2021

Checking the Contents of the Package

If the wrong instrument or accessories have been delivered, or if some accessories are missing or defective, contact the dealer from which you purchased them.

Current probe (model 701930) main body

Manuals 1 set

Carrying case

Safety Precautions

This instrument is designed to be used by a person with specialized knowledge.

This instrument meets the requirements of IEC-61010.

The general safety precautions described herein must be observed during all phases of operation. If the instrument is used in a manner not specified in this manual, the protection provided by the instrument may be impaired. YOKOGAWA assumes no liability for the customer's failure to comply with these requirements. In addition, before using the probe, read the manuals of the measuring instrument to thoroughly familiarize yourself with its specifications and operation.

The following symbols are used on this instrument.



To avoid injury, death of personnel or damage to the instrument, the operator must refer to an explanation in the User's Manual or Service Manual.



Both direct and alternating current.



Do not apply around or remove from HAZARDOUS LIVE conductors.

Notes about Usage



WARNING

- Do not clamp bare conductors to avoid short circuits or personal injury when the sensor head is open or measuring.
 - Be careful not to damage the insulation surface of the conductor under measurement.
 - Connect the power supply to the probe power terminal (option) of a waveform measuring instrument such as Yokogawa DL/DLM series, or use the power supply 701934 or 700938.
 - Be careful of electric shock when connecting the probe to the device under measurement.
 - Read and observe the safety precautions of the instruments to be connected to.
 - To avoid electric shock, do not get the instrument wet or use it with wet hands.
-

French



AVERTISSEMENT

- Ne serrez pas les conducteurs nus pour éviter les courts-circuits ou les blessures lorsque la tête du capteur est ouverte ou en mesure de mesurer.
 - Veillez à ne pas endommager la surface d'isolation du conducteur à mesurer.
 - Connectez l'alimentation à la borne d'alimentation de la sonde (option) d'un instrument de mesure de forme d'onde tel que la série Yokogawa DL/DLM, ou utilisez l'alimentation 701934 ou 700938.
 - Faites attention aux chocs électriques lors de la connexion de la sonde à l'appareil à mesurer.
 - Lisez et respectez les consignes de sécurité des instruments auxquels vous souhaitez vous connecter.
 - Pour éviter les chocs électriques, ne mouillez pas l'instrument et ne l'utilisez pas avec les mains mouillées.
-



CAUTION

- Do not subject the instrument to vibrations or shocks when transporting and handling it. Be especially careful to avoid dropping it.
 - Do not store or operate the instrument in an environment with direct sunlight, high temperature, high humidity, or condensation. The instrument may be deformed, or deteriorated in insulation, and it may not meet the specifications.
 - Before using the instrument, inspect and check the operation for malfunctions due to storage or transport conditions. If a malfunction is found, contact your dealer or YOKOGAWA representative.
 - The instrument is not dustproof or waterproof. Do not use it in a dusty or wet environment.
 - The sensor head is a precision assembly composed of a molded component, a ferrite core and a Hall effect element. Handle the instrument with care as it may be damaged by sudden changes in ambient temperature, mechanical stress or shock.
 - The matching surfaces of the sensor head are precision ground. Handle the instrument with care as scratches on the surfaces may impair performance.
 - Gently wipe off any dust or dirt on the matching surfaces of the sensor head with a soft cloth. It may generate resonance noise or impair performance.
 - Do not bend or pull the sensor cable or power cable to avoid damage due to disconnection.
 - Current sensors can be damaged by static electricity. Be careful not to apply static electricity to the instrument including the following cases.
 - Touching the sensor head with an object charged with static electricity
 - Touching the sensor head with an object with an electrical potential difference
 - A user charged with static electricity touching the core surface when cleaning the matching surfaces of the sensor head
(When cleaning the surfaces, take static electricity measures such as wearing an antistatic wrist strap.)
 - Gently wipe the instrument with a soft cloth moistened with a small amount of water or mild detergent. Do not use detergents containing organic solvents such as benzine, alcohol, acetone, ethers, ketones, thinners or gasoline. They may deform or discolor the instrument.
 - When the power is on, keep the sensor head closed, except when clamping the conductor under measurement. Leaving it open may damage the instrument.
-



ATTENTION

- Ne soumettez pas l'instrument à des vibrations ou à des chocs lors de son transport et de sa manipulation. Faites particulièrement attention à ne pas le laisser tomber.
- Ne stockez pas et n'utilisez pas l'instrument dans un environnement exposé à la lumière directe du soleil, à une température élevée, à une humidité élevée ou à la condensation. L'instrument peut être déformé ou détérioré au niveau de l'isolation, et il peut ne pas répondre aux spécifications.
- Avant d'utiliser l'instrument, inspectez et vérifiez que le fonctionnement ne présente pas de dysfonctionnements dus aux conditions de stockage ou de transport. En cas de dysfonctionnement, contactez votre revendeur ou représentant YOKOGAWA.
- Cet instrument n'est pas étanche à la poussière ou à l'eau. Ne l'utilisez pas dans un environnement poussiéreux ou humide.
- La tête de capteur est un assemblage de précision comprenant un composant moulé, un noyau de ferrite et un élément à effet Hall. Manipulez cet appareil avec précaution car il peut être endommagé par des changements brusques de température ambiante, des contraintes mécaniques ou des chocs.
- Les surfaces correspondantes de la tête du capteur sont rectifiées avec précision. Manipulez l'instrument avec précaution, car les rayures sur les surfaces peuvent altérer les performances.
- Essuyez délicatement la poussière ou la saleté sur les surfaces correspondantes de la tête du capteur avec un chiffon doux. Cela peut générer un bruit de résonance ou altérer les performances.
- Ne pliez pas et ne tirez pas sur le câble du capteur ou le câble d'alimentation pour éviter les dommages dus à la déconnexion.
- Les capteurs de courant peuvent être endommagés par l'électricité statique. Veillez à ne pas appliquer d'électricité statique à l'instrument, y compris dans les cas suivants.
 - Toucher la tête du capteur avec un objet chargé d'électricité statique
 - Toucher la tête du capteur avec un objet présentant une différence de potentiel électrique
 - Un utilisateur chargé d'électricité statique touchant la surface du noyau lors du nettoyage des surfaces correspondantes de la tête du capteur
(Lors du nettoyage des surfaces, prenez des mesures contre l'électricité statique telles que le port d'un bracelet antistatique.)

-
- Essuyez doucement l'instrument avec un chiffon doux humidifié avec une petite quantité d'eau ou de détergent doux. N'utilisez pas de détergents contenant des solvants organiques tels que le benzène, l'alcool, l'acétone, les éthers, les cétones, les diluants ou l'essence. Ils peuvent déformer ou décolorer l'instrument.
 - Lorsque l'appareil est sous tension, maintenez la tête du capteur fermée, sauf lors du serrage du conducteur à mesurer. Le laisser ouvert peut endommager l'instrument.

Note

- Accurate measurement may be impossible in locations subject to strong external magnetic fields, such as near transformers and high-current conductors, or in locations subject to strong external electric fields, such as near radio transmission equipment.
 - Depending on the current frequency that is measured, oscillation may occur, but this has no effect on measurements.
-

Regulations and Sales in Various Countries and Regions

Waste Electrical and Electronic Equipment (WEEE)



(EU WEEE Directive valid only in the EEA* and UK WEEE Regulation in the UK)

This product complies with the WEEE marking requirement. This marking indicates that you must not discard this electrical/electronic product in domestic household waste. When disposing of products in the EEA or UK, contact your local Yokogawa office in the EEA or UK respectively.

* EEA: European Economic Area

Authorized Representative in the EEA (AR)

Yokogawa Europe B.V. is the authorized representative of Yokogawa Test & Measurement Corporation for this product in the EEA. To contact Yokogawa Europe B.V., see the separate list of worldwide contacts, PIM 113-01Z2.

Disposal

When disposing of YOKOGAWA products, follow the laws and ordinances of the country or region where the product will be disposed of.

Conventions Used in This Manual



Improper handling or use can lead to injury to the user or damage to the instrument. This symbol appears on the instrument to indicate that the user must refer to the user's manual for special instructions. The same symbol appears in the corresponding place in the user's manual to identify those instructions. In the manual, the symbol is used in conjunction with the word "WARNING" or "CAUTION."

WARNING

Describes precautions that should be observed to prevent serious injury or death to the user.

CAUTION

Describes precautions that should be observed to prevent minor or moderate injury, or damage to the instrument.

French

AVERTISSEMENT

Attire l'attention sur des gestes ou des conditions susceptibles de provoquer des blessures graves (voire mortelles), et sur les précautions de sécurité pouvant prévenir de tels accidents.

ATTENTION

Attire l'attention sur des gestes ou des conditions susceptibles de provoquer des blessures légères ou d'endommager l'instrument ou les données de l'utilisateur, et sur les précautions de sécurité susceptibles de prévenir de tels accidents.

Note

Provides important information for the proper operation of the instrument.

Contents

1

2

List of Manuals.....	i
Checking the Contents of the Package.....	ii
Safety Precautions.....	ii
Regulations and Sales in Various Countries and Regions.....	vii
Conventions Used in This Manual	viii

Chapter 1 701930 Current Probe

Product Overview.....	1-1
Features.....	1-1
Names of Parts	1-2
Description of Parts.....	1-3
Operating Procedure.....	1-4
Handling Precautions.....	1-4
Preparations for Measurement	1-4
Demagnetizing and Zero Adjustment.....	1-5
Measurement Procedure	1-6
Specifications.....	1-9
Product Specifications	1-9
Compliant Standards	1-10

Chapter 2 Malfunction? First, Investigate.

Corrective Action to be Taken in Case of an Abnormality	2-1
---	-----

Chapter 1 701930 Current Probe

Product Overview

This unit can be directly connected to a BNC input connector of a waveform measuring instrument such as YOKOGAWA DL/DLM series, and by clamping it to a conductor to be measured, allows the current waveform to be easily captured.

Features

- Highly accurate current detection
- Easy current measurement
- Wideband frequency characteristics; DC to 10 MHz
- Wide clamp permits measurement of high current levels
- Easy protect function during excessive input

Names of Parts

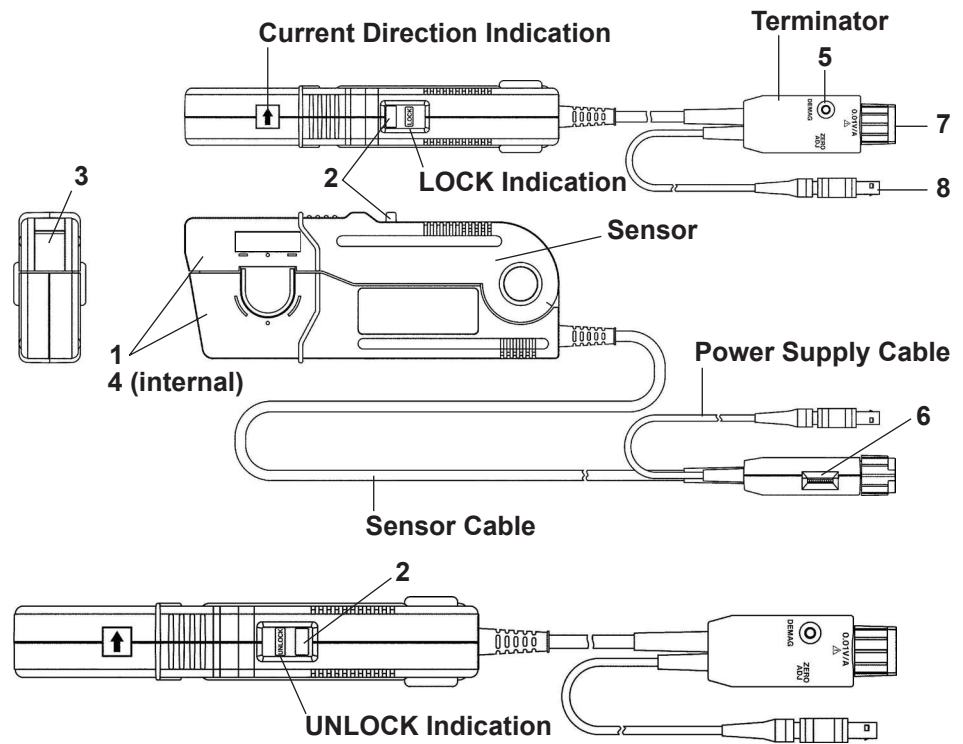

Description of Parts

1 Clamp

The part which clamps to the conductor to be measured.

2 Clamp Lever

The lever for opening and closing the clamp. Make sure to open or close the clamp only by using the clamp lever.

3 Clamp Lock

Locks the clamp in place when it is closed.

4 Sensor Head

This clamps the conductor being measured, and carries out the actual current measurement. It is a precision assembly including a molded component, a ferrite core, and a Hall effect element. It may be damaged if subjected to sudden changes in ambient temperature, or mechanical strain or shock, and therefore great care should be exercised in handling it.

5 Demagnetizing Switch (DEMAG)

If the core has been magnetized by switching the power ON and OFF, or by an excessive input, this switch demagnetizes it. Always carry out demagnetizing before measurement. The demagnetizing process takes about three seconds. During demagnetizing, a demagnetizing waveform is output.

6 Zero Adjustment Dial (ZERO ADJ)

Use the zero adjustment dial to correct for the effect of a voltage offset or temperature drift on the unit. When performing measurements, always carry out a zero adjustment after demagnetizing.

7 Output Connector

The current waveform of the measured conductor is output at a constant rate (0.01 VA in conjunction with the waveform measuring instrument with an input impedance of 1 M Ω .)

Connect to the BNC input connector of the waveform measuring instrument.

Note

- The output of this unit is terminated internally. Use a high-impedance input to the measuring instrument. With an input impedance of 50 Ω , accurate measurement is not possible.
 - If using BNC-banana plug or similar adapters to connect to input terminals other than BNC connectors, make sure the polarity is correct.
 - Turn the clamp lever until it clicks, and check that it is locked securely.
-

8 Power Plug

Connect the power plug to the receptacle on the power supply (model 701934 or 700938) to supply power to the sensor and terminator.

Operating Procedure

Handling Precautions



WARNING

- Do not clamp bare conductors to avoid short circuits or personal injury when the sensor head is open or measuring.
 - Be careful not to damage the insulation surface of the conductor under measurement.
 - Do not short-circuit between the two measurement lines with the metal part of the sensor unit. It may lead to a serious accident such as the occurrence of an arc.
 - Connect the power supply to the probe power terminal (option) of a waveform measuring instrument such as Yokogawa DL/DLM series, or use the power supply 701934 or 700938.
 - Be careful of electric shock when connecting the probe to the device under measurement.
 - Read and observe the safety precautions of the instruments to be connected to.
 - To avoid electric shock, do not get the instrument wet or use it with wet hands.
-

Preparations for Measurement



CAUTION

When using a 701930 current probe, it may not be possible to use multiple active probes at the same time with the 701934, 700938 power supply, or the probe power supply from a YOKOGAWA waveform measuring instrument. Make sure that the total current consumption of each active probe does not exceed the current specifications of the probe power supply. The current consumption of the probe depends on the measured current (refer to the figure below).

See the following YOKOGAWA website for the usage limitations for each measuring instrument.

<https://tmi.yokogawa.com/solutions/products/oscilloscopes/current-probes/>

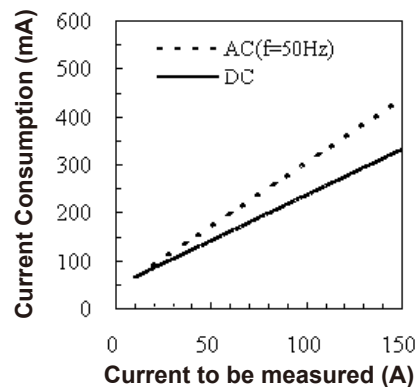

Current consumption* vs. current to be measured (typical)

* The sum total of a positive and negative current consumption.

1. Have the power supply 701934/700938, and oscilloscope or recorder for waveform measurement ready.
2. Turn the power switch OFF and connect the power cord.
3. Connect the power plug of the 701930 to the power receptacle of the 701934/700938.
4. Turn the 701934/700938 power switch ON, and check that the front panel power indicator lights.

Note

The output of this unit is terminated internally. Use a high-impedance input to the measuring instrument. With an input impedance of 50 Ω , accurate measurement is not possible. When power is supplied to the 701930, a demagnetizing waveform might be generated.

Demagnetizing and Zero Adjustment



CAUTION

- When disconnecting the output connector, be sure to release the lock before pulling the connector. Forcibly pulling the connector without releasing the lock, or pulling on the cable will result in damage to the terminator.
- If using BNC-banana plug or similar adapters to connect to input terminals other than BNC connectors, make sure the polarity is correct.
- Do not demagnetize when the clamp is connected to a conductor. Doing so might damage the components of the circuit being measured.
- Do not begin supplying power to the 701930 after the clamp has been connected to a conductor. Doing so might damage the components of the circuit being measured.

1. With the waveform measurement instrument input at ground, adjust the trace to the zero position.
2. Set the input coupling of the waveform measurement instrument to DC.
3. Connect the output connector of the 701930 to the input connector of the waveform measurement instrument. Turn the clamp lever until it clicks, and check that it is locked securely.

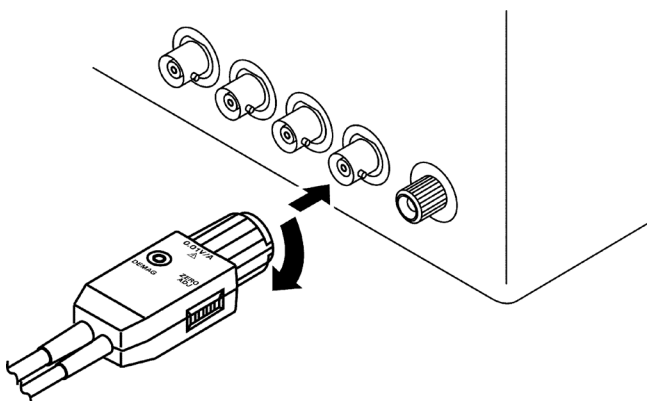

-
4. Without clamping the conductor to be measured, press the clamp lever until the **LOCK** indication appears (and the **UNLOCK** indication disappears), and then check that the clamp is properly closed.
 5. Press the demagnetizing switch (DEMAG) on the terminator.
 6. Turn the zero adjustment dial on the terminator to adjust the trace to the zero position.

Note

- The output of this unit is terminated internally. Use a high-impedance input to the measuring instrument. With an input impedance of 50 Ω , accurate measurement is not possible.
 - Oscillation may occur when you execute DEMAG, but this has no effect on measurements.
 - The positive side of the waveform that is generated when you execute DEMAG may not be symmetrical to the negative side, but this has no effect on measurements.
-

Measurement Procedure



CAUTION

- The maximum continuous input range is based on heat that is internally generated during measurement. Never input current in excess of this level. Doing so may result in damage to the probe.
- The maximum continuous input range varies according to the frequency of the current being measured. See page 1-9, "Product Specifications."
- If excess current is input, generated heat activates a built-in safety function that blocks normal output. If this happens, remove the input immediately (remove the sensor from the conductor being measured, or reduce the input current to zero). Wait until the sensor has had sufficient time to cool before resuming operation.
- Heat generated by an input current whose frequency is 1 kHz or higher is mainly due to self-heating of the sensor head. In this case, the protection function is not activated. Therefore, be careful of burns, short circuits, and other accidents or sensor damage and the like caused by the temperature increase.
- If you continuously input a current even if it is below the maximum current value established by the maximum continuous input range, the self-heating of the sensor may cause the safety function of the instrument to activate in order to prevent damage to the instrument.
- At high ambient temperatures, the built-in safety circuit may activate at current input levels below the rated continuous maximum.
- Continuous input of current exceeding the rated maximum, or repeated activation of the safety function may result in damage to the unit.

- The probe is rated for maximum input under two conditions in addition to the input maximums shown in the Product Specifications. These are: (1) 300 Apeak, for non-continuous input, and (2) 500 Apeak at Pulse Width $\leq 30 \mu\text{s}$. (1) indicates an upper waveform response limit of 300 Apeak. Use the sensor at RMS current input levels that are within the rated continuous maximums. (2) indicates the upper response limit for a single input pulse. Use the sensor at levels not exceeding this value.
- Open the clamp only by using clamp lever.
- To maintain the probe accuracy within the specifications and to verify that correct measurement results are being obtained, periodic calibration is necessary. The calibration period varies depending on your operating environment and the frequency of use. We recommend that you set a calibration period according to the frequency of use and ask us to calibrate it periodically.

1. Check that the system is safe, and that the preparations described in the preceding section have been carried out.
2. Pull the sensor opening lever so that the sensor head opens.
3. Align the sensor so that the current direction indication corresponds to the direction of current flow through the conductor to be measured, and clamp so that the conductor is in the center of the sensor aperture.

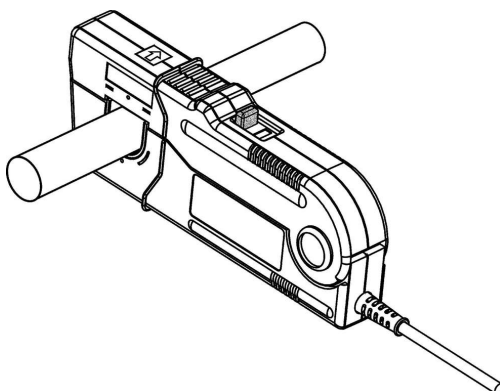

4. Press the clamp lever on the sensor head until the **LOCK** indicator appears (and the **UNLOCK** indication disappears), and check that the opening lever is firmly locked and the clamp is securely closed.
5. It is now possible to monitor the current waveform. The output voltage rate of the 701930 is 0.01 V/A. Convert the voltage sensitivity of the waveform observation instrument to current sensitivity. For example, if the voltage sensitivity is 10 mV/DIV, the current sensitivity is 1 A/DIV.

Note

- The output of this unit is terminated internally. Use a waveform measurement instrument with an input impedance of at least 1 M Ω .
- Immediately after powering on, this unit may be subject to an appreciable offset drift due to the effect of self-heating. To counteract this, allow the unit to warm up for about 30 minutes before carrying out measurement.

-
- When performing continuous measurements, be aware that the offset voltage drifts depending on factors such as the ambient temperature.
 - Under certain circumstances, oscillation may occur if the probe is connected to the power supply 701934/700938 while the power supply is ON. In such cases, oscillation can be stopped and operation restored to normal by opening and closing the clamp with the clamp lever.
 - Depending on the measured current value or its frequency, resonant sounds may be generated from the clamp. This will have no effect on measurement.
 - The reading may be affected by the position within the clamp aperture of the conductor being measured. The conductor should be in the center of the clamp aperture.
 - When carrying out measurement, press the clamp lever until the **LOCK** indication appears (and the **UNLOCK** indication disappears), and check that the clamp is properly closed. If the clamp is not properly closed, accurate measurement will not be possible.
 - At high frequencies, common mode noise may affect measurements taken on the high voltage side of circuits. If this occurs, reduce the frequency range of the waveform measuring instrument, or clamp onto the low-voltage side of the circuit, as appropriate.

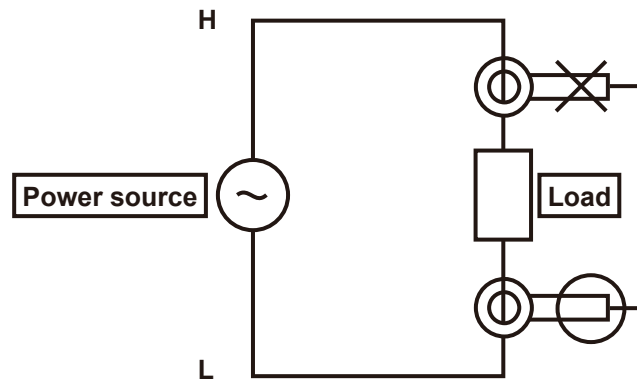

- Directly after powering ON, the demagnetizing waveform appears in the output; this is not a malfunction.
 - Accurate measurement may be impossible in locations subject to strong external magnetic fields such as transformers and high-current conductors, or in locations subject to strong external electric fields such as radio transmission equipment.
-

Specifications

Product Specifications

Accuracy is guaranteed at 23 ± 3 °C after the power has been on for 30 minutes.

Frequency Band*	DC to 10 MHz (-3 dB) (Typical characteristics shown in the next page, Fig.1)
Rise Time*	35 ns or less
Maximum Continuous Input	150 A (Derating according to frequency shown in the next page, Fig.2)
Maximum Peak Current	Non-Continuous 300 A _{peak} , or 500 A _{peak} at pulse width \leq 30 μ s.
Output Voltage Rate*	0.01 V/A
Amplitude Accuracy*	0 to 150 A: $\pm 1\%$ of reading ± 1 mV 150 A to 300 A _{peak} : $\pm 2\%$ of reading (DC, 45 to 66 Hz)
Noise*	Equivalent to 25 mArms or less (for 20 MHz band measuring instrument)
Insertion Impedance	(Typical characteristics shown in the next page, Fig.3)
Temperature Coefficient for Sensitivity*	$\pm 2\%$ or less (with 55 Hz, 150 A input in a range of 0 to 40 °C)
Propagation Delay	40 ns (Typical)
Maximum Rated Power	5.5 V _{Amax} (at the maximum continuous input)
Rated Supply Voltage	± 12 V ± 1 V
Operating Temperature and Humidity Range	0 to 40 °C, 80% RH or less (no condensation)
Storage Temperature and Humidity Range	-10 to 50 °C, 80% RH or less (no condensation)
Location for Use	Indoor use, altitude up to 2000 m
Effect of External Magnetic Fields	Equivalent to a maximum of 150 mA (in a DC or 60 Hz, 400 A/m magnetic field)
Measurable Conductors	Insulated conductors
Diameter of Measurable Conductors	\varnothing 20 mm
Guaranteed Accuracy Period	1 year (up to 10000 open and close operations)
Cable Lengths	Sensor Cable: Approx. 2 m Power Supply Cable: Approx. 1 m
External Dimensions	Sensor: Approx. 176 (W) \times 69 (H) \times 27 (D) mm Terminator: Approx. 27 (W) \times 55 (H) \times 18 (D) mm
Weight	Approx. 500 g
Accessories	User's manual, carrying case

* In conjunction with a waveform measuring instrument with an input impedance of 1 M Ω \pm 1%

Compliant Standards

Safety Standards	EN 61010-1 EN 61010-2-032 Type D Pollution degree 2 *1
EMC Standards	Emissions EN 61326-1 Class B EN 55011 Class B Group 1 EMC Regulatory Arrangement in Australia and New Zealand EN 55011 Class B Group 1
	Immunity EN 61326-1 Table 1 (Basic immunity requirement)
Environmental Standards *2	EU RoHS Directive compliant

*1 Pollution degree applies to the degree of adhesion of a solid, liquid, or gas which deteriorates withstand voltage or surface resistivity. Pollution degree 2 applies to normal indoor atmospheres (usually with only non-conductive pollution).

*2 For conformity to environmental regulations and/or standards other than EU, contact your local Yokogawa office (PIM 113-01Z2).

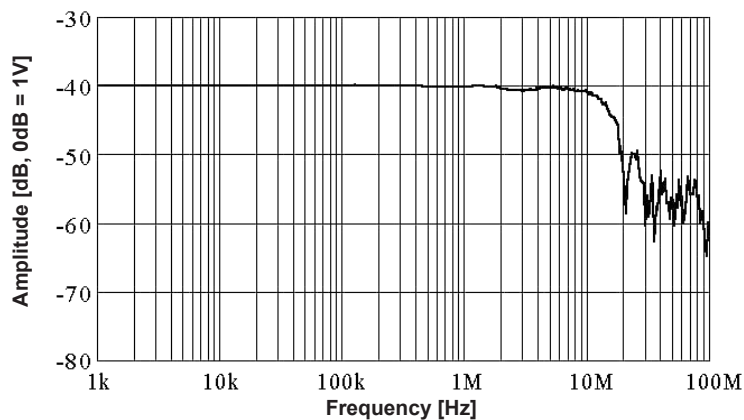

Figure 1 Frequency Characteristics (Typical Characteristics)

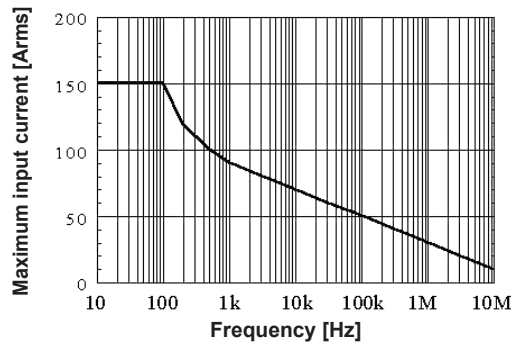

Figure 2 Derating According to Frequency

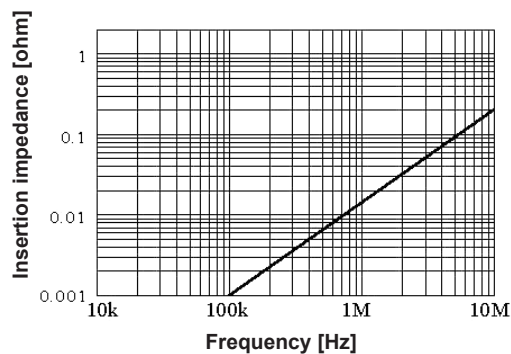

Figure 3 Insertion Impedance (Typical Characteristics)

Chapter 2 Malfunction? First, Investigate.

Corrective Action to be Taken in Case of an Abnormality

If maintenance service is required, or if the instrument still does not operate properly even after proper corrective action has been taken, contact your nearest YOKOGAWA representatives listed on the back cover of this manual.

Symptom	Possible Cause	Corrective Action
Cannot make DC measurements (or at low frequencies up to few hundred Hertz) or the amplitude is small in the given frequency region.	Power is not turned ON.	Turn ON the power.
	The measurement instrument, such as an oscilloscope, is set to AC coupling.	Set the instrument to DC coupling.
	The sensor is not locked (it is not hooked securely).	Lock the sensor.
Cannot adjust to the zero level using the zero adjustment dial.	The sensor is magnetized.	Demagnetize the sensor before adjusting the zero level.
The amplitude is small across all frequencies.	The input impedance of the measurement instrument, such as an oscilloscope, is set to 50 Ω .	Set it to 1 M Ω .