



SIC
重庆川仪

电站测温专用热电偶（阻）

使用说明书

**Power Station Temperature
Measurement –Dedicated
Thermocouple (Thermal
Resistance)**

Installation and Use Instructions

重庆川仪十七厂有限公司

**Chongqing Chuanyi Instrument No.17 Factory Co.,
Ltd.**

特 别 提 示

Particular Notes

本说明书仅限于下列产品使用：

The Instructions is restricted to be applied in the following products:

WR□KD 电站用铠装热电偶

WR□KD sheathed thermocouple for power station

WZPKD 电站用铠装热电阻

WZPKD sheathed thermal resistance for power station

重庆川仪十七厂有限公司

目录

Contents

1. 概述.....	1
1. Overview.....	1
2. 分度表及允差.....	2
2. Reference tables and tolerances.....	2
3. 热响应时间.....	3
3. Thermal response time.....	3
4. 适用环境.....	4
4. Application environment.....	4
5. 安装使用要求.....	5
5. Installation and use requirements.....	5
6. 热电偶接线图.....	5
6. Wiring diagram of thermocouple.....	5
7. 热电阻接线图.....	7
7. Wiring diagram of thermal resistance.....	7
8. 典型安装示意图.....	10
8. Typical installation schematic diagram.....	10

9. 维护与修理.....	13
9. Maintenance and repair.....	13
10. 贮存.....	19
10. Storage.....	19
11. 补充说明.....	20
11. Supplementary instructions.....	20

重庆川仪十七厂有限公司

电站测温专用热电偶（阻）

使用说明书

Temperature Measurement Thermocouple

(Thermal Resistance) for Power Station

Operation Instructions

警告！

Warning!

1. 安装使用前，请认真阅读本使用说明书；
1. Please read the Operation Instructions carefully before installation and use
2. 本产品技术规范可能发生改变，恕不另行通知。
2. Change may happen on the Product Technical Specification, please forgive us to have no further notice.



1. 概述

1. Overview

铠装热电偶是新型的温度传感器，具有体形细长、热响应快、抗振动、耐高压、使用寿命长以及便于弯曲等优点。

Sheathed thermocouple, a new type of temperature of sensor, has the advantage of long and thin shape, rapid thermal response, vibration resistance, high pressure resistance, long service life, flexibility and so on.

本产品执行标准：

Executive standard of the product:

GB/T18404-2001 《铠装热电偶电缆及铠装热电偶》；

GB/T18404-2001 *Mineral Insulated Thermocouple Cables and Thermocouples*;

JB/T8205-1999 《廉金属铠装热电偶电缆》。

JB/T8205-1999 *Sheathed Base Metal Thermocouple Cables*

铠装铂热电阻是由铂电阻组件、内引线、绝缘材料、金属导管组合而成的坚实体。具有精度高、稳定性好、线径小，可任意弯曲，热响应快，可绕性好，抗震，耐压，抗冲击，适应性强等特点。

Sheathed platinum thermal resistance, a solid device made up of platinum resistance components, intraconnection track, insulation materials, metal conduit and so on, has the characteristics of high precision, perfect stability, small wire diameter, flexible bending, rapid thermal response, good reliability, vibration resistance, pressure resistance, shock resistance, strong adaption and so on.

铠装铂热电阻执行标准：

Executive standard of sheathed platinum thermal resistance:

Q/CY235-2006 《铠装铂热电阻技术条件》。

Q/CY235-2006 *Specification of Armoured Platinum Thermal Resistance*

2. 分度表及允差

2. Reference tables and tolerances

热电偶分度表及允差执行标准：

Executive standard of references tables and tolerances for thermocouple:

GB/T 16839.1-1997 《热电偶 第1部分：分度表》

GB/T 16839.1-1997 *Thermocouples Part 1: Reference Tables*

GB/T 16839.2-1997 《热电偶 第2部分：允差》

GB/T 16839.1-1997 *Thermocouples Part 2: Tolerances*

热电阻执行标准：

Executive standard of thermal resistance:

JB/T8622-1997 《工业铂热电阻技术条件及分度表》

JB/T8622-1997 *Technical Specification and Reference Table for Industrial Platinum Thermal Resistance*

3. 热响应时间

3. Thermal response time

3.1 铠装热电偶的热响应时间

3.1 Thermal response time of sheathed thermocouple

表 1 铠装热电偶的热响应时间

Table 1 Thermal response time of sheathed thermocouple

$\tau_{0.5,s}$ 测量端	铠装热电偶直径 (mm)										
	0.25	0.5	1.0	1.5	2.0	3.0	4.0	4.5	5.0	6.0	8.0
露端型	—	—	0.1	0.2	0.3	0.4	0.5	0.6	0.7	0.8	1.0
接壳型	0.1	0.2	0.2	0.3	0.4	0.6	0.8	1.0	1.2	2.0	4.0
绝缘型	0.1	0.4	0.6	0.8	1.0	2.0	2.5	3.0	4.0	6.0	8.0

$\tau_{0.5,s}$ Measuring end	Sheathed thermocouple diameter (mm)										
	0.25	0.5	1.0	1.5	2.0	3.0	4.0	4.5	5.0	6.0	8.0
Exposed junction type	—	—	0.1	0.2	0.3	0.4	0.5	0.6	0.7	0.8	1.0
Shorted junction type	0.1	0.2	0.2	0.3	0.4	0.6	0.8	1.0	1.2	2.0	4.0
Isolated junction	0.1	0.4	0.6	0.8	1.0	2.0	2.5	3.0	4.0	6.0	8.0

type											
------	--	--	--	--	--	--	--	--	--	--	--

3.2 铠装热电阻的热响应时间

3.2 Thermal response time of sheathed thermal resistance

表 2 铠装热电阻的热响应时间

Table 2 Thermal response time of sheathed thermal resistance

外径 (mm)	热响应时间 $\tau_{0.5}$ (s)
$\leq\Phi 5$	≤ 20
$>\Phi 5$	≤ 30

External diameter(mm)	Thermal response time $\tau_{0.5}$ (s)
$\leq\Phi 5$	≤ 20
$>\Phi 5$	≤ 30

4. 适用环境

4. Application environment

4.1 防护等级

4.1 Protection grade

热电偶（阻）接线盒防护等级为 IP66/IP68。

Protection grade of thermocouple (thermal resistance) junction box is IP66/IP68.

4.2 环境温度

4.2 Environment temperature

- 热电偶(阻)参比端(接线盒外)的温度一般不应超过 100℃, 并保持其稳定不变。

- Temperature of thermocouple (thermal resistance) reference junction (on the exterior of junction box) shall not exceed 100 °C and keep stable and invariant.
- 应避免装在炉门旁边或与加热物体距离过近及具有强磁场
- 之外，热电偶（阻）的热线盒不可碰到被测介质的容器壁。
- In addition to avoid being installed on the side of fire door or being close to heating objects as well as having high-intensity magnetic field, Thermocouple (thermal resistance) junction box shall not contact container wall of mediums measured.

5. 安装使用要求

5. Installation and use requirements

NPT系列及ZG系列等锥螺纹在现场使用时，应加强对螺纹连接处的密封处理，如缠绕生胶带或涂覆密封胶。

When taper threads of NPT, ZG and other series are used on the spot, sealing treatment of thread joints shall be strengthened, such as wrapping raw tape or coating sealant.

6. 热电偶接线图

6. Wiring diagram of thermocouple

在接线时，先打开接线盒盖，然后根据图 1 所示接线板种类查找表 3，按表 3 规定的接线规则进行接线。

When wiring, open the cover of the junction box firstly; then, look up Table 3 in accordance with type of wiring board presented on Fig. 1 and make wiring in accordance with wiring rules specified in Fig. 3.

图 1 热电偶接线板

Fig. 1 wiring board of thermocouple

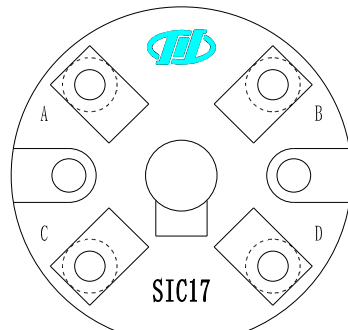

4P-R

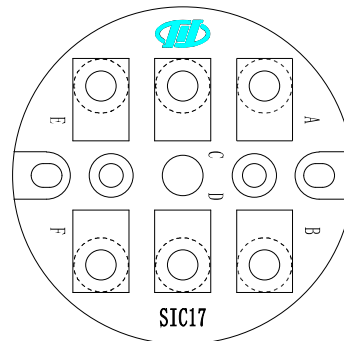

6P-RZ

表 3 接线板接线规则
Table 3 wiring rules of wiring board

产品类别	接线板类型	
	4P-R	6P-RZ
铠偶单支式	A+D-	C+D-
铠偶双支式	A+B-,C+D-	A+E-,F+B-

Product category	Type of wiring board	
	4P-R	6P-RZ
Single sheathed thermocouple type	A+D-	C+D-
Dual Sheathed thermocouple	A+B-,C+D-	A+E-,F+B-

注：实际使用时未在图 1 和表 3 所示的接线板和接线规则的接线方式，应根据实际标识进行接线。

Note: During practical use, mode of wiring of wiring board and wiring rules not presented in Fig. 1 and Table 3 shall be wired in accordance with actual mark and sign.

7. 热电阻接线图

7. Wiring diagram of thermal resistance

在接线时，先打开接线盒盖，然后根据图 2 所示接线板种类查找表 4，按表 4 规定的接线规则进行接线。

When wiring, open the cover of the junction box firstly; then, look up Table 4 in accordance with type of wiring board presented on Fig. 2 and make wiring in accordance with wiring rules specified in Fig. 4.

图 2 热电阻接线板

Fig. 2 wiring board of thermal resistance

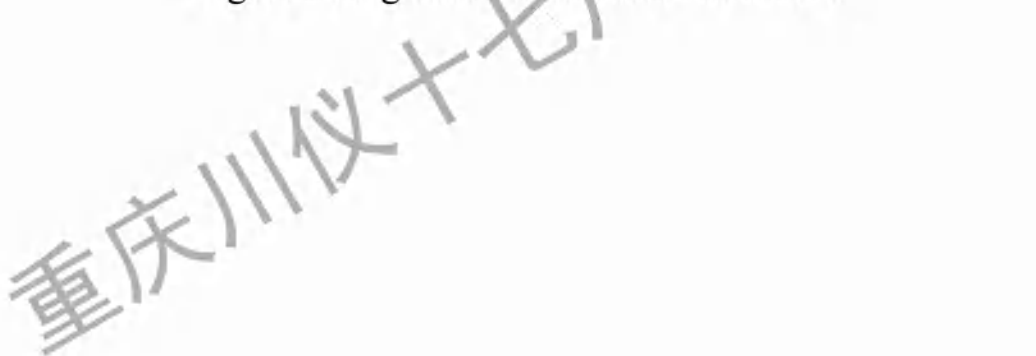

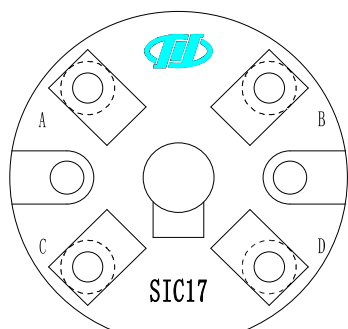

4P-R

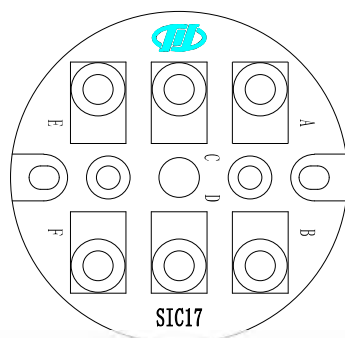

6P-RZ

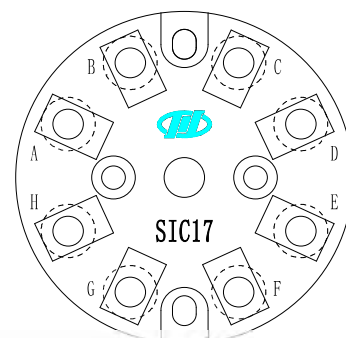

8P-RZ

表 4 接线板接线规则

Table 4 wiring rules of wiring board

产品类别	接线板类型		
	4P-R	6P-RZ	8P-RZ
铠阻单支式 (3 线制)	A+B-D-	A+B-F-	—
铠阻单支式 (4 线制)	A+C+B-D-	A+E+B-F-	—
铠阻双支式 (4 线制)	—	—	G+H+A-B- C+D+E-F-
铠阻双支式 (3 线制)	—	A+C-E-, F+D-B-	—

Product category	Type of wiring board		
	4P-R	6P-RZ	8P-RZ
Single sheathed thermal resistance	A+B-D-	A+B-F-	—

type (three-wire system)			
Single sheathed thermocouple type (four-wire system)	A+C+B-D-	A+E+B-F-	—
Dual Sheathed thermal resistance (four-wire system)	—	—	G+H+A-B- C+D+E-F-
Dual Sheathed thermal resistance (three -wire system)	—	A+C-E-, F+D-B-	—

注：实际使用时未在图 2 和表 4 所示的接线板和接线规则的接线方式，应根据实际标识进行接线。

Note: During practical use, mode of wiring of wiring board and wiring rules not presented in Fig. 2 and Table 4 shall be wired in accordance with actual mark and sign.

8. 典型安装示意图

8. Typical installation schematic diagram



图3 电站 01A 型
Fig. 3
01A power station

图4 电站 01B 型
Fig. 4
01B power station

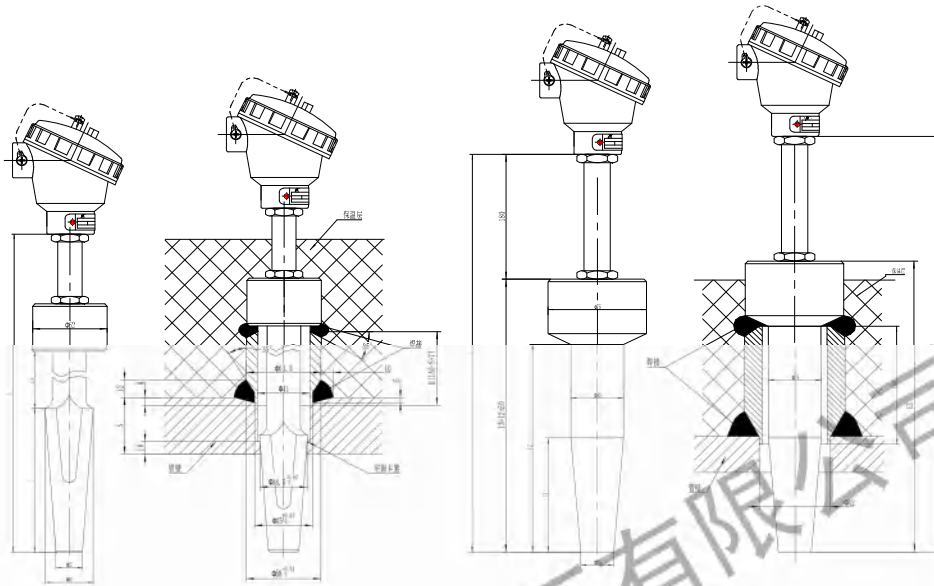

图 5 电站 02A 型

Fig. 5

02A power station

图 6 电站 02B 型

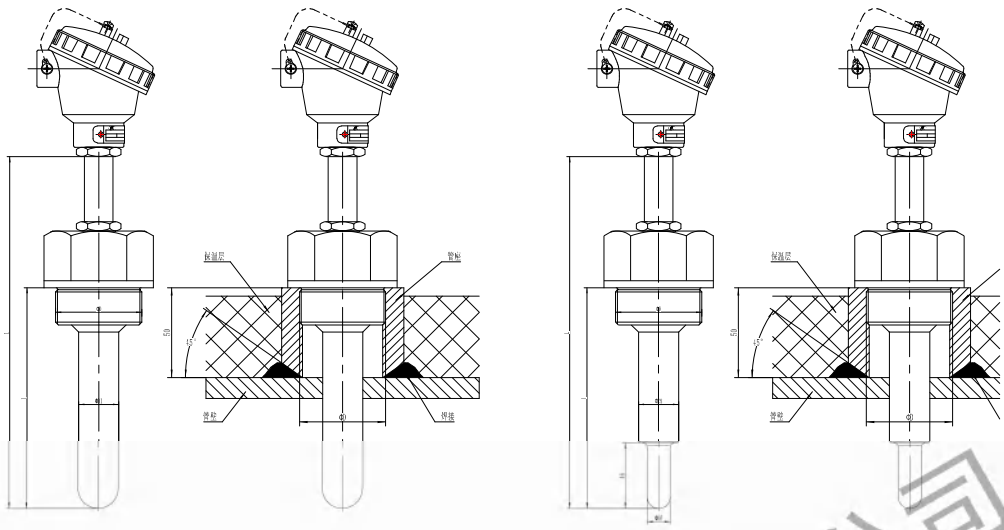
Fig. 6

02B power station

重庆川仪十七厂有限公司



图 7 电站 03A 型

Fig. 7

03A power station

图 8 电站 03B 型

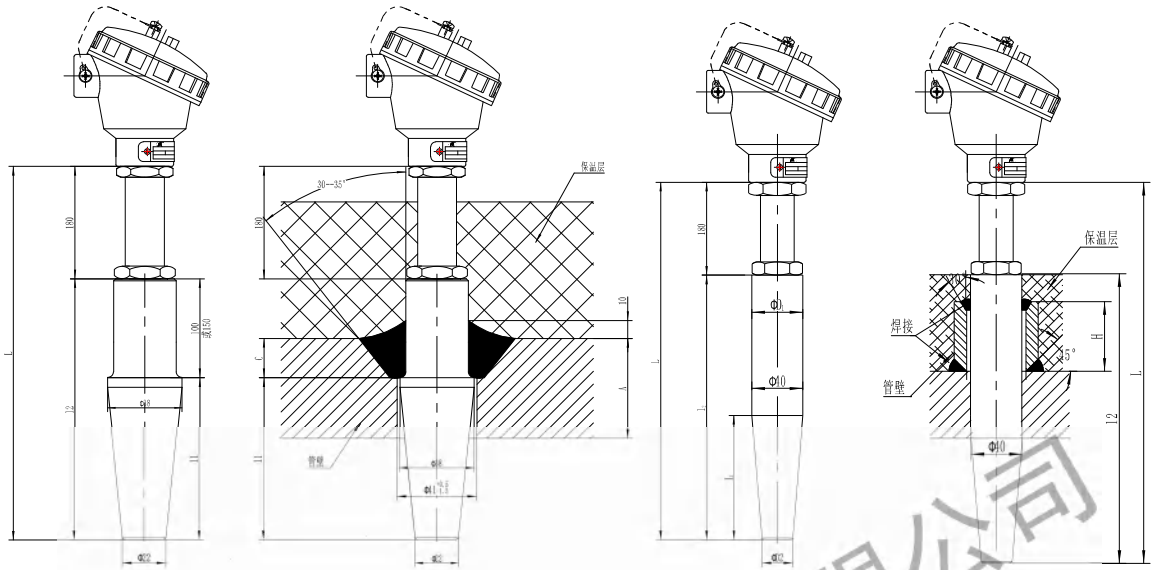
Fig. 8

03B power station

重庆川仪十七厂有限公司



图 9 电站 04 型

Fig. 9

04 power station

图 10 电站 05 型

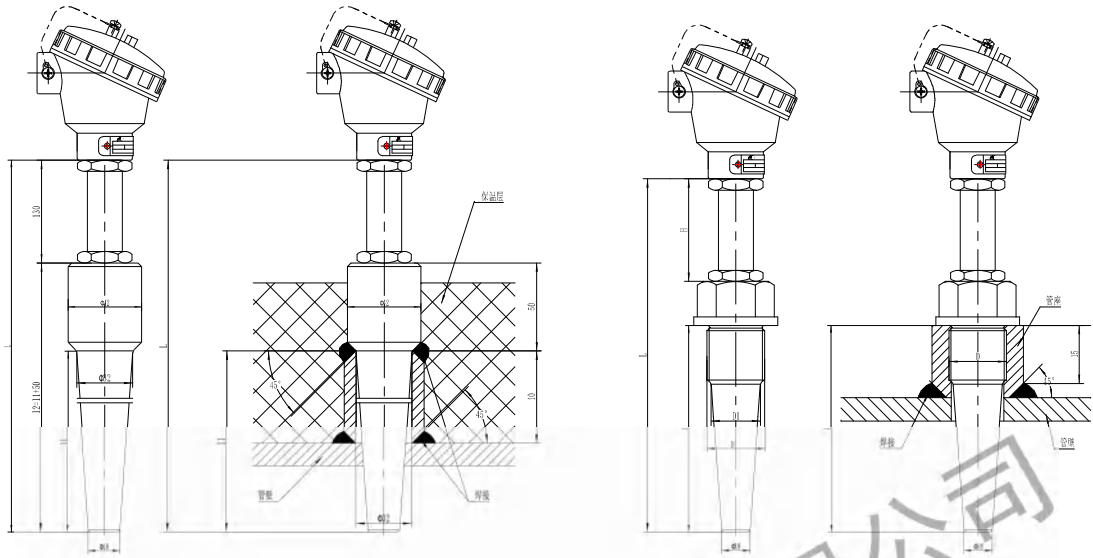
Fig. 10

05 power station

9. 维护与修理

9. Maintenance and repair

9.1 维护

9.1 Maintenance

定期检查接线盒盖、引入装置密封塞是否良好；安装是否牢固；防松装置是否有效；接地是否牢靠。

Check the performance of the cover of the junction box and sealing plug of lead-in device is good or not at fixed period, firmness of

installation, effectiveness of locking device and reliability of ground connection.

9.2 修理

9.2 Repair

(1) 热电偶简单故障修理

(1) Repair of simple thermocouple faults

表 5 热电偶故障现象及修理方法

Table 5 Thermocouple fault phenomena and repairing methods



序号	故障现象	可能原因	修理方法
1	热电势比实际应有的小（仪表指示值偏低）	<p>(1) 热电偶内部电极漏电（短路）</p> <p>(2) 热电偶接线盒内接线柱短路。</p> <p>(3) 热电偶偶丝变质或工作端损坏。</p>	<p>(1) 将热电偶感温元件取出，检查漏电原因，若是因潮湿引起，应将热电偶感温元件烘干，若是绝缘管绝缘不良，则应更换。</p> <p>(2) 打开接线盒清洁接线柱，清除造成短路的原因。</p> <p>(3) 更换元件。</p>
2	指示仪表无指示	热电偶断路	更换元件。
3	仪表指示值不稳定（仪表本身无故障的情况下）	<p>(1) 接线盒内感温元件和补偿导线接触不良。</p> <p>(2) 热电极有断续短路和断续接地现象。(3) 热电偶安装不牢而发生振动。</p>	<p>(1) 打开接线盒，重新紧固。</p> <p>(2) 更换元件。</p> <p>(3) 将热电偶牢固安装。</p>

No.	Fault phenomenon	Possible cause	Repairing method
1	Thermoelectric potential is smaller than due value in	(1) Electric leakage of internal electrode of thermocouple (short circuit)	(1) Take out the heat responsive element of thermocouple and check the cause of electric

No.	Fault phenomenon	Possible cause	Repairing method
	practice (instrument indicating value is low)	(2) short circuit on binding post in the junction box of thermocouple (3) Metamorphism of thermo wire or breakdown of working end of thermocouple.	leakage. If it is caused by moist, heat responsive element of thermocouple shall be dried; if it is caused by poor insulation of insulation tube, the insulation tube shall be changed. (2) Open the junction box and clean the binding post to eliminate the cause leading to short circuit. (3) Replace components
2	No indication of indicating instrument	Disconnection of thermocouple	Replace components
3	Instability of instrument indicating value (in case of the instrument itself is fault-free)	(1) Poor contact of heat responsive element and compensating lead wire in the junction box. (2) Interrupted short circuit and ground connection of	(1) Open the junction box and refasten the instrument. (2) Replace components. (3) Install the thermocouple firmly.

No.	Fault phenomenon	Possible cause	Repairing method
		thermode. (3) Occurance of vibration due to unfirm installation of thermocouple.	

(2) 热电阻简单故障修理

(2) Repair of simple thermal resistance faults

表 6 热电阻故障现象及修理方法

Table 6 Thermal resistance fault phenomena and repairing Methods

序号	故障现象	可能原因	修理方法
1	热电势比实际应有的小（仪表指示值偏低）	（1）热电阻内部电极漏电（短路） （2）热电阻接线盒内接线柱短路。 （3）热电阻偶丝变质或工作端损坏。	（1）将热电阻感温元件取出，检查漏电原因，若是因潮湿引起，应将热电阻感温元件烘干，若是绝缘管绝缘不良，则应更换。 （2）打开接线盒清洁接线柱，清除造成短路的原因。 （3）更换元件。
2	指示仪表无指示	热电阻断路	更换元件。
3	仪表指示值不稳定（仪表本身无故障的情况下）	（1）接线盒内感温元件和补偿导线接触不良。 （2）热电极有断续短路和断续接	（1）打开接线盒，重新紧固。 （2）更换元件。 （3）将热电阻牢固安装。

序号	故障现象	可能原因	修理方法
		地现象。(3) 热电阻安装不牢而发生振动。	

No.	Fault phenomenon	Possible cause	Repairing method
1	Thermoelectric potential is smaller than due value in practice (instrument instructing value is low)	(1) Electric leakage of internal electrode of thermal resistance (short circuit) (2) short circuit on binding post in the junction box of thermal resistance (3) Metamorphism of thermo wire or breakdown of working end of thermal resistance.	(1) Take out the heat responsive element of thermal resistance and check the cause of electric leakage. If it is caused by moist, heat responsive element of thermal resistance shall be dried; if it is caused by poor insulation of insulation tube, the insulation tube shall be changed. (2) Open the junction box and clean the binding post to eliminate the cause leading to short circuit. (3) Replace components

No.	Fault phenomenon	Possible cause	Repairing method
2	No indication of indicating instrument	Disconnection of thermal resistance	Replace components.
3	Instability of instrument indicating value (in case of the instrument itself is fault-free)	<p>(1) Poor contact of heat responsive element and compensating lead wire in the junction box.</p> <p>(2) Interrupted short circuit and ground connection of thermode.</p> <p>(3) Occurance of vibration due to infirm installation of thermal resistance.</p>	<p>(1) Open the junction box and refasten the instrument.</p> <p>(2) Replace components.</p> <p>(3) Install the thermal resistance firmly.</p>

10. 贮存

10. Storage

热电偶（阻）应贮存在周围环境温度 10-35℃，相对湿度不高于 80%，且空气中不含可能使零部件腐蚀的介质中。

Thermocouple (thermal resistance) shall be stored in 10-35 °C surrounding environment temperature with relative humidity less than 80%. Moreover, any mediums that may corrode the components shall not be contained in the air.

11. 补充说明

11. Supplementary instructions

11.1 产品验收

11.1 Product acceptance

收到本产品后,请及时按产品国家标准或我厂标准规定的出厂检验项目验收。若有质量问题,请于收货之日起一个月内(以用户来函邮戳日期为准)函告我厂,我厂将及时受理。逾期则被视为已验收合格。

After receiving the product, please timely conduct inspection and acceptance in accordance with product national standard or factory inspection items stipulated by us. In case of any quality problem, please inform us by letters within one month after date of receiving (subject to the postmark date of letter from users), and we will approach any issues proposed without delay. Expiry will be regarded as accepted and qualified.

11.2 关于热电偶(阻)测试问题

11.2 For test problems of thermocouple (thermal resistance)

请各位用户在验收时注意几个问题:

Please pay attention to the following items during check and acceptance:

(1) 采用相应等级标准监测温度;

(1) Monitor temperature of corresponding grade and standard shall be adopted;

(2) 标准偶(阻)与被测偶(阻)的测量端必须在同一等温区;

(2) Measuring ends of the standard thermocouple (thermal resistance) and the thermocouple (thermal resistance) measured must be placed in the same isothermal region.

(3) 保证足够的浸入深度;

(3) Enough immersion depth shall be ensured;

(4) 避免因绝缘体或保护管污染和漏电造成测试误差;

(4) Test error shall be avoided due to pollution of insulator or protective tube and electric leakage;

(5) 测试时必须温度稳定;

(5) Temperature must keep stabilized during test;

(6) 标准偶（阻）与被测偶（阻）参比端置于同一冰点;

(6) Reference junctions of standard thermocouple (thermal resistance) and the thermocouple (thermal resistance) measured shall be placed in the same freezing point;

(7) 连接相同等级的补偿导线。

(7) Compensating conductor of same grade shall be connected to.

11.3 我公司提供的包装物有可能对贵方的环境造成影响，请妥善处理。

11.3 Please properly dispose the packing materials supplied by our company that may influence the environment.

重 庆 川 仪 十 七 厂 有 限 公 司

地址：重庆市北碚区

邮编：400700

电话：0086-023-68261104

传真：0086-023-68263847

网址：<http://www.sic17.cn/>

印刷日期：2016年6月

Chongqing Chuanyi Instrument No.17 Factory Co., Ltd.

Address: Beibei District, Chongqing City

Zip code: 400700

Tel: 0086-023-68261104

Fax: 0086-023-68263847

<http://www.sic17.cn/>

Printing date: June 2016