

# Current transducer LF 2010-S/SP1

$I_{PN} = 2000 \text{ A}$

For the electronic measurement of current: DC, AC, pulsed..., with galvanic separation between the primary and the secondary circuit.

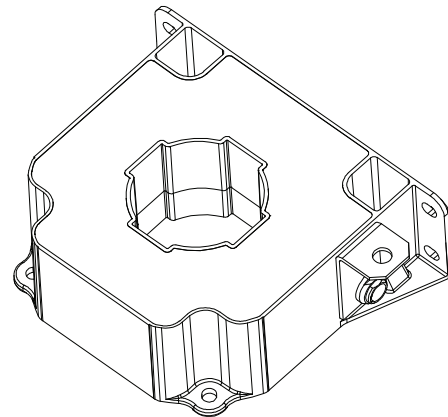

## Features

- Bipolar and insulated current measurement up to 3.5 kA
- Current output
- Closed loop (compensated) current transducer
- Panel mounting.

## Special features

- $I_{PM} = 0 \dots \pm 3500 \text{ A}$
- $U_C = \pm 15 \text{ V } (\pm 5 \%) \dots \pm 24 \text{ V } (+20 \%)$
- Internal shield connected to “ $-U_C$ ”
- Connection to secondary circuit on LEMO EEJ.1B.304.CYC.

## Advantages

- High accuracy
- Very low offset drift over temperature.

## Applications

- Single or three phase inverters
- Propulsion and braking choppers
- Propulsion converters
- High power drives
- Substations.

## Standards

- EN 50155: 2021
- EN 50124-1: 2017
- EN 50121-3-2: 2016
- UL 508: 2010.

## Application Domain

- Railway (fixed installations and onboard).

**Absolute maximum ratings**

Parameter	Symbol	Unit	Value
Maximum supply voltage (working) (-40 ... 85 °C)	$\pm U_{C \max}$	V	±28.8
Primary conductor temperature	$T_B$	°C	100
Maximum steady state primary current (-40 ... 85 °C)	$I_{PN \max}$	A	2000

Stresses above these ratings may cause permanent damage.  
Exposure to absolute maximum ratings for extended periods may degrade reliability.

**UL 508: Ratings and assumptions of certification**

File # E189713 Volume: 2 Section: 9

**Standards**

- USR indicates investigation to the Standard for Industrial Control Equipment UL 508.
- CNR indicates investigation to the Canadian standard for Industrial Control Equipment CSA C22.2 No. 14-13

**Conditions of acceptability**

When installed in the end-use equipment, with primary feedthrough potential involved of 600 V AC/DC, consideration shall be given to the following:

- 1 - *These products must be mounted in a suitable end-use enclosure.*
- 2 - *The secondary pin terminals have not been evaluated for field wiring.*
- 3 - *Low voltage control circuit shall be supplied by an isolating source (such as transformer, optical isolator, limiting impedance or electro-mechanical relay).*
- 4 - *Based on the temperature test performed on all Series, the primary bar or conductor shall not exceed 100 °C in the end use application.*

**Marking**

Only those products bearing the UL or UR Mark should be considered to be Listed or Recognized and covered under UL's Follow-Up Service. Always look for the Mark on the product.

**Insulation coordination**

Parameter	Symbol	Unit	Value	Comment
RMS voltage for AC insulation test, 50 Hz, 1 min	$U_d$	kV	10	
Impulse withstand voltage 1.2/50 $\mu$ s	$U_{Ni}$	kV	23	
Partial discharge RMS test voltage ( $q_m < 10$ pC)	$U_t$	kV	4.8	Test carried out with a non insulated primary bar of 290 × 50 × 10 mm, centered in the through-hole
Insulation resistance	$R_{INS}$	M $\Omega$	200	measured at 500 V DC
Application example Rated insulation voltage RMS voltage	$U_{Nm}$	V	3000	Reinforced insulation according to IEC 62497-1, CAT III, PD2
Application example Rated insulation voltage RMS voltage	$U_{Nm}$	V	4800	Basic insulation according to IEC 62497-1, CAT III, PD2
Clearance (pri. - sec.)	$d_{Cl}$	mm	39.5	Shortest distance through air
Creepage distance (pri. - sec.)	$d_{Cp}$	mm	41.2	Shortest path along device body
Comparative tracking index	$CTI$		600	
Case material	-	-	V0	According to UL 94

**Environmental and mechanical characteristics**

Parameter	Symbol	Unit	Min	Typ	Max	Comment
Ambient operating temperature	$T_A$	°C	-40		85	
Ambient storage temperature	$T_{A\text{st}}$	°C	-50		90	
Equipment operating temperature class						EN 50155: OT6
Switch-on extended operating temperature class						EN 50155: ST0
Rapid temperature variation class						EN 50155: H2
Conformal coating type						EN 50155: NA
Mass	$m$	g		1500		

**RAMS data**

Parameter	Symbol	Unit	Min	Typ	Max
Useful life class					EN 50155: L4
Mean failure rate	$\bar{\lambda}$	h <sup>-1</sup>		1/2961551.6	According to IEC 62380: 2004 $T_A = 45$ °C ON: 20 hrs/day ON/OFF: 320 cycles/year $U_C = \pm 24$ V, $I_p = 2000$ A DC

**Electrical data**

At  $T_A = 25\text{ °C}$ ,  $\pm U_C = \pm 24\text{ V}$ ,  $R_M = 1\ \Omega$ , unless otherwise noted.

Lines with a \* in the conditions column apply over the  $-40 \dots 85\text{ °C}$  ambient temperature range.

Parameter	Symbol	Unit	Min	Typ	Max	Conditions
Primary nominal RMS AC current DC current	$I_{PN}$	A			2000	* $\pm U_C = \pm 28.8\text{ V}$
Primary nominal RMS AC and DC current					2000	$\pm U_C = \pm 28.8\text{ V}, -40 \dots 70\text{ °C}$
Primary current, measuring range	$I_{PM}$	A	-3500		3500	*
Measuring resistance	$R_M$	$\Omega$	0			* Max value of $R_M$ is given in <a href="#">figure 1</a>
Secondary nominal RMS current	$I_{SN}$	A			0.4	*
Resistance of secondary winding	$R_S$	$\Omega$			18.6	$R_S(T_A) = R_S \times (1 + 0.004 \times (T_A + \Delta\text{temp} - 25))$ Estimated temperature increase @ $I_{PN}$ is $\Delta\text{temp} = 15\text{ °C}$
Secondary current	$I_S$	A	-0.7		0.7	*
Number of secondary turns	$N_S$			5000		
Nominal sensitivity	$S_N$	mA/A		0.2		
Supply voltage	$\pm U_C$	V	$\pm 14.25$		$\pm 28.8$	*
Current consumption	$I_C$	mA		$42 + I_S$ $48 + I_S$ $52 + I_S$		$\pm U_C = \pm 15\text{ V}$ $\pm U_C = \pm 24\text{ V}$ $\pm U_C = \pm 28.8\text{ V}$
Inrush current						NA (EN 50155)
Interruptions on power supply voltage class						NA (EN 50155)
Supply change-over class						NA (EN 50155)
Offset current, referred to primary	$I_O$	A	-1		1	
Temperature variation of $I_O$ , referred to primary	$I_{OT}$	A	-1		1	*
Magnetic offset current, referred to primary	$I_{OM}$	A		$\pm 1$		After $3 \times I_{PN}$
Sensitivity error	$\varepsilon_S$	%	-0.15		0.15	*
Linearity error	$\varepsilon_L$	% of $I_{PN}$	-0.1		0.1	*
Total error	$\varepsilon_{tot}$	% of $I_{PN}$	-0.2 -0.3		0.2 0.3	25 ... 70 ... 85 °C * -40 ... 85 °C
RMS noise current referred to primary	$I_{no}$	mA		90		1 Hz to 20 kHz ( <a href="#">see figure 4</a> )
Delay time to 10 % of the final output value $I_{PN}$ step	$t_{D10}$	$\mu\text{s}$		< 0.5		0 to 1 kA, 200 A/ $\mu\text{s}$
Delay time to 90 % of the final output value $I_{PN}$ step	$t_{D90}$	$\mu\text{s}$		< 0.5		0 to 1 kA, 200 A/ $\mu\text{s}$
Frequency bandwidth	$BW$	kHz		150		-3 dB, small signal bandwidth

**Definition of typical, minimum and maximum values**

Minimum and maximum values for specified limiting and safety conditions have to be understood as such as values shown in "typical" graphs.

On the other hand, measured values are part of a statistical distribution that can be specified by an interval with upper and lower limits and a probability for measured values to lie within this interval.

Unless otherwise stated (e.g. "100 % tested"), the LEM definition for such intervals designated with "min" and "max" is that the probability for values of samples to lie in this interval is 99.73 %.

For a normal (Gaussian) distribution, this corresponds to an interval between -3 sigma and +3 sigma. If "typical" values are not obviously mean or average values, those values are defined to delimit intervals with a probability of 68.27 %, corresponding to an interval between -sigma and +sigma for a normal distribution.

Typical, minimum and maximum values are determined during the initial characterization of the product.

Typical performance characteristics

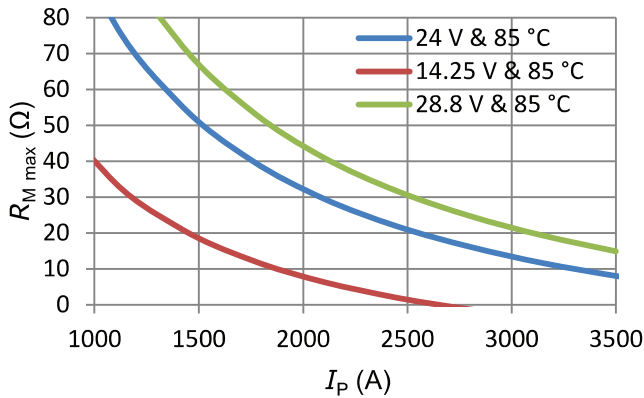

Figure 1: Maximum measuring resistance

$$R_{M \max} = N_S \times \frac{U_{C \min} - 1.3 \text{ V}}{I_P} - R_{S \max} \Omega$$

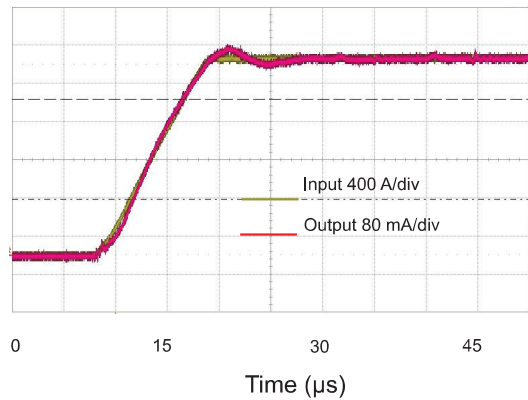

Figure 2: Typical step response (0 to 2 kA, 200 A/μs)

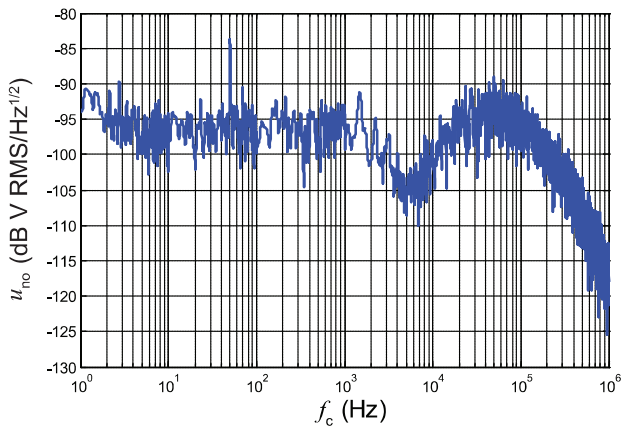

Figure 3: Typical noise voltage density  $u_{no}$  with  $R_M = 100 \Omega$

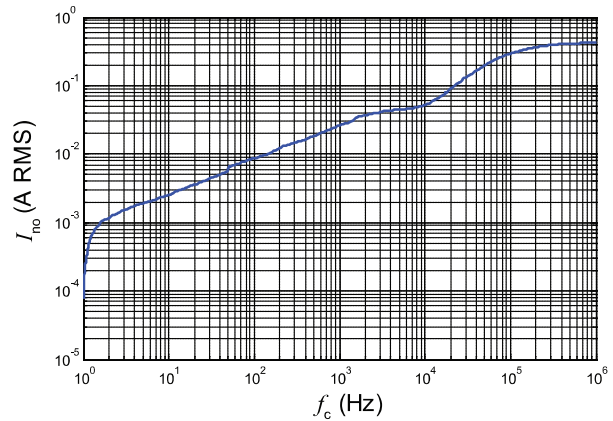

Figure 4: Typical total output current noise with  $R_M = 100 \Omega$  (primary referred, RMS)

To calculate the noise in a frequency band  $f_1$  to  $f_2$ , the formula is:

$$I_{no}(f_1 \dots f_2) = \sqrt{I_{no}(f_2)^2 - I_{no}(f_1)^2}$$

with  $I_{no}(f)$  read from figure 4 (typical, RMS value).

Example:

What is the noise from 1 to  $10^6$  Hz?

Figure 4 gives  $I_{no}(1 \text{ Hz}) = 0.2 \text{ mA}$  and  $I_{no}(10^6 \text{ Hz}) = 400 \text{ mA}$ . The output current noise (RMS) is therefore:

$$\sqrt{(400 \times 10^{-3})^2 - (0.2 \times 10^{-3})^2} = 400 \text{ mA referred to primary}$$

Typical performance characteristics

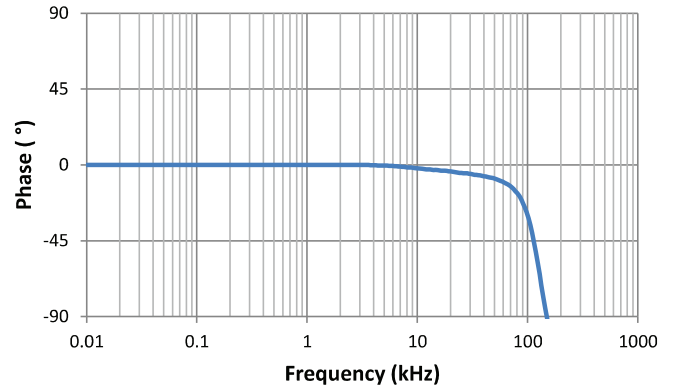
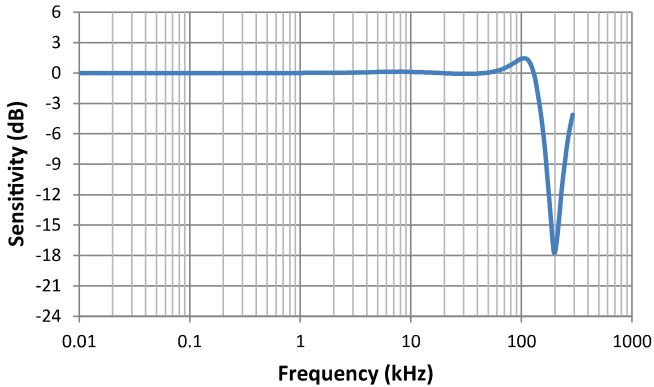

Figures 5 and 6: Typical frequency response, small signal bandwidth

Performance parameters definition

Sensitivity and linearity

To measure sensitivity and linearity, the primary current (DC) is cycled from 0 to  $I_{PM}$ , then to  $-I_{PM}$  and back to 0 (equally spaced  $I_{PM}/10$  steps). The sensitivity  $S$  is defined as the slope of the linear regression line for a cycle between  $\pm I_{PM}$ . The linearity error  $\epsilon_L$  is the maximum positive or negative difference between the measured points and the linear regression line, expressed in % of the maximum measured value.

Magnetic offset

The magnetic offset  $I_{OM}$  is the change of offset after a given current has been applied to the input. It is included in the linearity error as long as the transducer remains in its measuring range.

Electrical offset

The electrical offset current  $I_{OE}$  is the residual output current when the input current is zero.

Total error

The total error  $\epsilon_{tot}$  is the error at  $\pm I_{PN}$ , relative to the rated value  $I_{PN}$ . It includes all errors mentioned above.

Delay times

The delay time  $t_{D10}$  @ 10 % and the delay time  $t_{D90}$  @ 90 % with respect to the primary are shown in the next figure. Both slightly depend on the primary current  $di/dt$ . They are measured at nominal current.

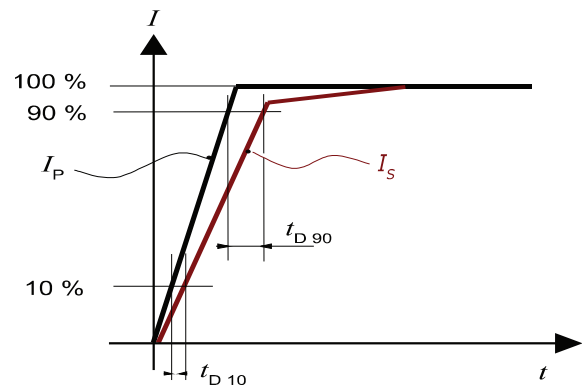
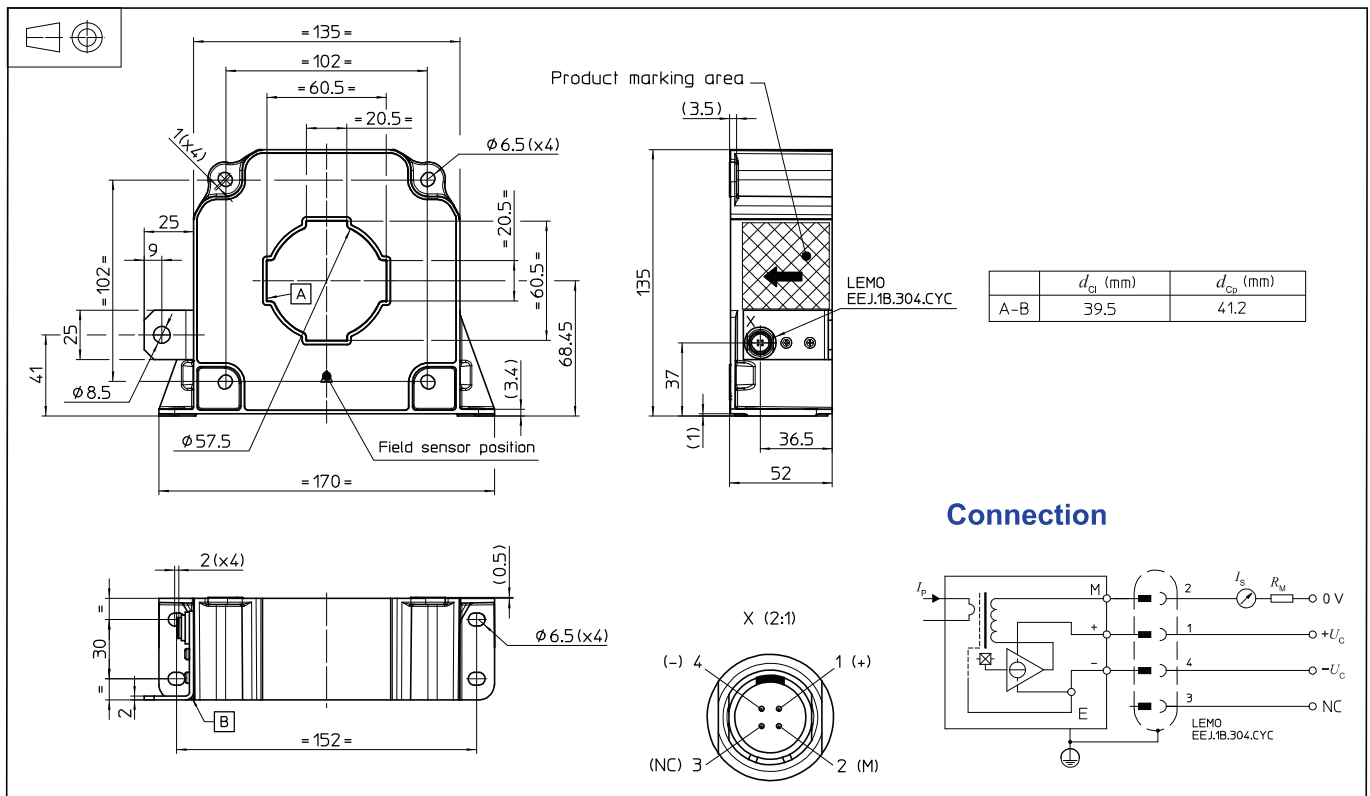

Figure 7:  $t_{D10}$  (delay time @ 10 %) and  $t_{D90}$  (delay time @ 90 %)

Dimensions (in mm)



Mechanical characteristics

- General tolerance  $\pm 0.5$  mm
- Transducer fastening
  - Vertical position 4 slotted holes  $\varnothing 6.5$  mm
  - Recommended fastening torque 4 M6 steel screws 5.5 N·m ( $\pm 10\%$ )
- Primary through-hole
  - Or  $\varnothing 57$  mm
  - Or 60 mm x 20 mm
- Transducer fastening
  - Horizontal position 4 slotted holes  $\varnothing 6.5$  mm
  - 4 M6 steel screws
  - Recommended fastening torque 5.5 N·m ( $\pm 10\%$ )
- Connection of secondary LEMO EEJ.1B.304.CYC

Remarks

- $I_s$  is positive when  $I_p$  flows in the direction of arrow.
- The secondary cables also have to be routed together all the way.
- Installation of the transducer is to be done without primary current or secondary voltage present.
- Maximum temperature of primary conductor: see [page 2](#).
- Installation of the transducer must be done unless otherwise specified on the datasheet, according to LEM Transducer Generic Mounting Rules. Please refer to LEM document N°ANE120504 available on our Web site: <https://www.lem.com/en/file/3137/download>.

Note: Additional information available on request.

Safety

This transducer must be used in limited-energy secondary circuits according to IEC 61010-1.



This transducer must be used in electric/electronic equipment with respect to applicable standards and safety requirements in accordance with the manufacturer's operating instructions.



Caution, risk of electrical shock

When operating the transducer, certain parts of the module can carry hazardous voltage (eg. primary connection, power supply).

Ignoring this warning can lead to injury and/or cause serious damage.

This transducer is a build-in device, whose conducting parts must be inaccessible after installation.

A protective housing or additional shield could be used.

Main supply must be able to be disconnected.