

# Current Transducer LF 306-S/SP10

For the electronic measurement of currents: DC, AC, pulsed..., with galvanic isolation between the primary circuit (high power) and the secondary circuit (electronic circuit).

## $I_{PN} = 300 \text{ A}$



16142

### Electrical data

$I_{PN}$	Primary nominal current rms	300	A
$I_{PM}$	Primary current, measuring range	0 .. $\pm 500$	A
$R_M$	Measuring resistance	$R_{M \min}$   $R_{M \max}$	
	with $\pm 12 \text{ V}$	@ $\pm 300 \text{ A}_{\max}$	0   37 $\Omega$
		@ $\pm 500 \text{ A}_{\max}$	0   8 $\Omega$
	with $\pm 15 \text{ V}$	@ $\pm 300 \text{ A}_{\max}$	13   56 $\Omega$
		@ $\pm 500 \text{ A}_{\max}$	13   20 $\Omega$
$I_{SN}$	Secondary nominal current rms	150	mA
$K_N$	Conversion ratio	1 : 2000	
$V_C$	Supply voltage (+5%)	$\pm 12 \dots 15$	V
$I_C$	Current consumption	20 (@ $\pm 15 \text{ V}$ ) + $I_S$	mA

### Accuracy - Dynamic performance data

$X_G$	Overall accuracy @ $I_{PN}$ , $T_A = 25^\circ\text{C}$	$\pm 0.4$	%
$\varepsilon_L$	Linearity error	$< 0.1$	%
$I_O$	Offset current @ $I_p = 0$ , $T_A = 25^\circ\text{C}$	Typ	$\pm 0.20$ mA
		Max	$\pm 0.20$ mA
$I_{OM}$	Magnetic offset current <sup>1)</sup> @ $I_p = 0$ and specified $R_M$ , after an overload of $3 \times I_{PN}$	$\pm 0.08$	mA
$I_{OT}$	Temperature variation of $I_O$ - $25^\circ\text{C} \dots +70^\circ\text{C}$	$\pm 0.20$   $\pm 0.64$	mA
$t_{ra}$	Reaction time @ 10 % of $I_{PN}$	$< 500$	ns
$t_r$	Response time <sup>2)</sup> to 90 % of $I_{PN}$ step	$< 1$	$\mu\text{s}$
di/dt	di/dt accurately followed	$> 100$	A/ $\mu\text{s}$
BW	Frequency bandwidth (-1 dB)	DC .. 100	kHz

### General data

$T_A$	Ambient operating temperature	- 25 .. + 70	$^\circ\text{C}$
$T_S$	Ambient storage temperature	- 40 .. + 90	$^\circ\text{C}$
$R_S$	Secondary coil resistance @ $T_A = 70^\circ\text{C}$	34	$\Omega$
$m$	Mass	60	g
	Standards	EN 50178: 1997	

**Notes:** <sup>1)</sup> The result of the coercive field of the magnetic circuit

<sup>2)</sup> With a di/dt of 100 A/ $\mu\text{s}$ .

### Features

- Closed loop (compensated) current transducer using the Hall effect
- Isolated plastic case recognized according to UL 94-V0.

### Special features

- Printed circuit board mounting
- Connection to secondary circuit by pins, 0.64 x 0.64 mm.

### Advantages

- Excellent accuracy
- Very good linearity
- Low temperature drift
- Optimized response time
- Wide frequency bandwidth
- No insertion losses
- High immunity to external interference
- Current overload capability.

### Applications

- AC variable speed drives and servo motor drives
- Static converters for DC motor drives
- Battery supplied applications
- Uninterruptible Power Supplies (UPS)
- Switched Mode Power Supplies (SMPS)
- Power supplies for welding applications.

### Application domain

- Industrial.

## Current Transducer LF 306-S/SP10

### Isolation characteristics

$V_d$	Rms voltage for AC isolation test, 50 Hz, 1 min	6	kV
$\hat{V}_w$	Impulse withstand voltage 1.2/50 $\mu$ s	>7.3	kV
		Min	
<b>dCp</b>	Creepage distance	7.8	mm
<b>dCI</b>	Clearance distance	7.1	mm
<b>CTI</b>	Comparative Tracking Index (group III a)	175	

### Applications examples

According to EN 50178 and IEC 61010-1 standards and following conditions:

- Over voltage category OV 3
- Pollution degree PD2
- Non-uniform field

	EN 50178	IEC 61010-1
dCp, dCI, $\hat{V}_w$	Rated isolation voltage	Nominal voltage
Single isolation	600 V	600 V
Reinforced isolation	300 V	300 V

### Safety



This transducer must be used in electric/electronic equipment with respect to applicable standards and safety requirements in accordance with the manufacturer's operating instructions.



Caution, risk of electrical shock

When operating the transducer, certain parts of the module can carry hazardous voltage (eg. primary busbar, power supply).

Ignoring this warning can lead to injury and/or cause serious damage.

This transducer is a build-in device, whose conducting parts must be inaccessible after installation.

A protective housing or additional shield could be used.

Main supply must be able to be disconnected.

## Dimensions LF 306-S/SP10 (in mm. 1 mm = 0.0394 inch)

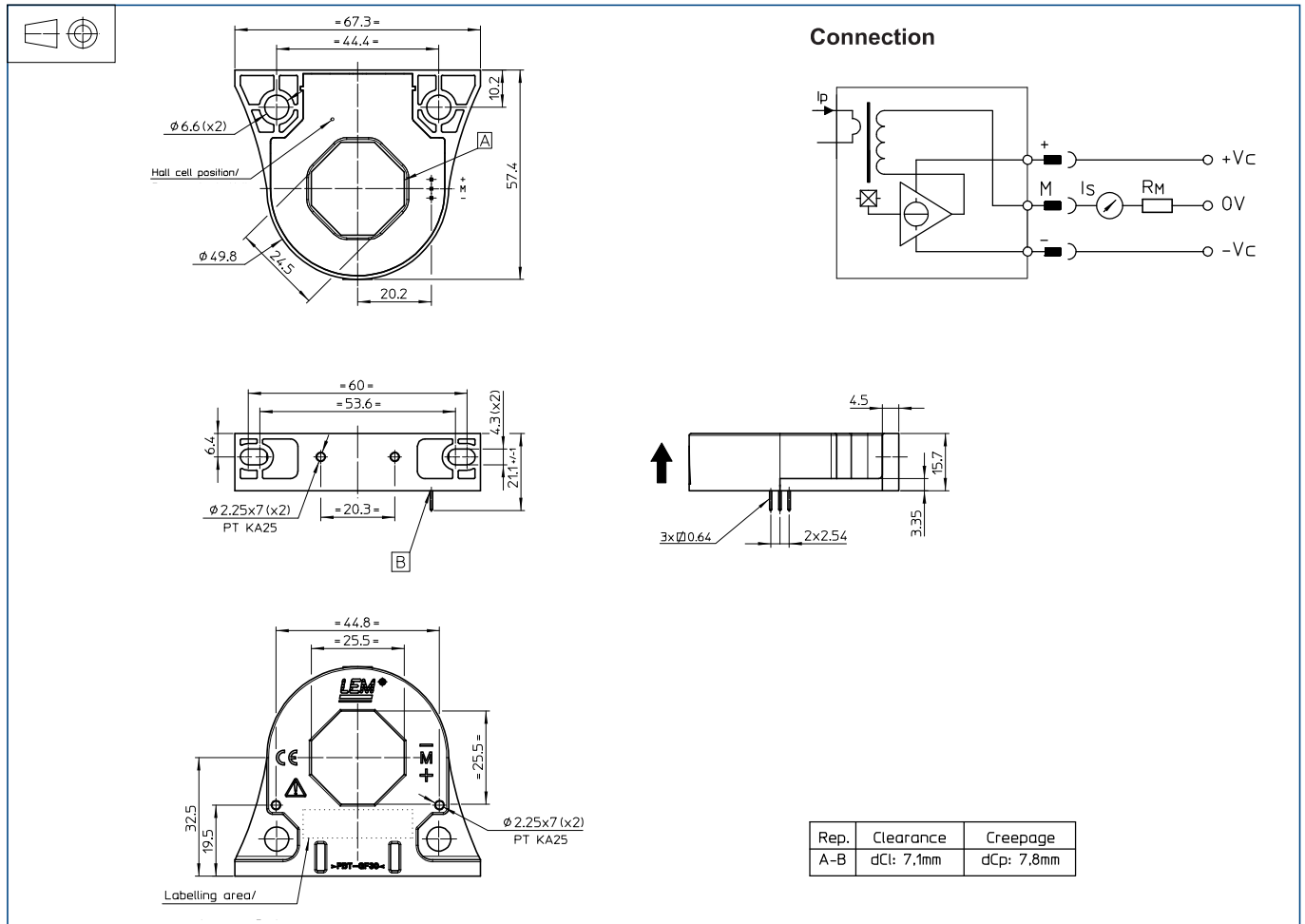

### Mechanical characteristics

- General tolerance  $\pm 0.5$  mm
- Transducer fastening
  - Vertical position
    - 2 holes  $\text{\O} 4.3$  mm
    - 2 steel screws M4
    - Recommended fastening torque 3 Nm
  - or
    - 2 holes  $\text{\O} 2.25$  mm,
    - 2 screws PTKA 25,
    - Recommended fastening torque 0.3 Nm
  - Flat position
    - 2 holes  $\text{\O} 6.6$  mm
    - 2 steel screws M6
- Recommended fastening torque 4.2 Nm
  - or
    - 2 holes  $\text{\O} 2.25$  mm,
    - 2 screws PTKA 25,
    - Recommended fastening torque 0.3 Nm
- Primary through-hole  $\text{\O} 25.5$  mm
- Connection of secondary
  - Pins  $0.64 \times 0.64$  mm
  - Recommended PCB hole 1.1 mm

### Remarks

- $I_s$  is positive when  $I_p$  flows in the direction of the arrow.
- Temperature of the primary conductor should not exceed  $100^\circ\text{C}$ .
- Dynamic performances ( $di/dt$  and response time) are best with a single bar completely filling the primary hole.