

Current Transducer LF 505-S/SP15

For the electronic measurement of currents: DC, AC, pulsed..., with galvanic separation between the primary circuit and the secondary circuit.

$$I_{PN} = 500 \text{ A}$$

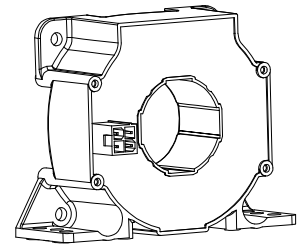

Electrical data

I_{PN}	Primary nominal RMS current	500	A
I_{PM}	Primary current, measuring range	0 ... ±800	A
R_M	Measuring resistance @ $T_A = 70 \text{ °C}$		
		$R_{M \min}$ $R_{M \max}$	
	with ±15 V	@ ±500 A _{max}	0 60 Ω
		@ ±800 A _{max}	0 11 Ω
	with ±18 V	@ ±500 A _{max}	0 92 Ω
		@ ±800 A _{max}	0 30 Ω
	with ±24 V	@ ±500 A _{max}	5 149 Ω
		@ ±800 A _{max}	5 65 Ω
I_{SN}	Secondary nominal RMS current	100	mA
N_P/N_S	Turns ratio	1 : 5000	
U_C	Supply voltage (±5 %)	±15 ... 24	V
I_C	Current consumption	24 (@ ±18 V) + I_S	mA

Accuracy - Dynamic performance data

ϵ_{tot}	Total error @ I_{PN} , $T_A = 25 \text{ °C}$	±0.6	%
ϵ_L	Linearity error	< 0.1	%
I_O	Offset current @ $I_P = 0$, $T_A = 25 \text{ °C}$	Typ Max	mA
I_{OT}	Temperature variation of I_O -10 °C ... +70 °C	±0.3 ±0.5	mA
t_{D90}	Delay time to 90 % of the final output value for I_{PN} step ¹⁾	< 1	µs
BW	Frequency bandwidth (-1 dB)	DC ... 100	kHz

General data

T_A	Ambient operating temperature	-10 ... +70	°C
T_{Ast}	Ambient storage temperature	-25 ... +85	°C
R_S	Resistance of secondary winding @ $T_A = 70 \text{ °C}$	70	Ω
m	Mass	230	g
	Standards	EN 50178: 1997 UL 508: 2010	

Note: ¹⁾ With a di/dt of 100 A/µs.

Features

- Closed loop (compensated) current transducer using the Hall effect
- Insulating plastic case recognized according to UL 94-V0.

Special feature

- Connection to secondary circuit on Molex Mini Fit Jr. 5566 with gold pin or equivalent.

Advantages

- Excellent accuracy
- Very good linearity
- Low temperature drift
- Optimized response time
- Wide frequency bandwidth
- No insertion losses
- High immunity to external interference
- Current overload capability.

Applications

- AC variable speed drives and servo motor drives
- Static converters for DC motor drives
- Battery supplied applications
- Uninterruptible Power Supplies (UPS)
- Switched Mode Power Supplies (SMPS)
- Power supplies for welding applications.

Application domain

- Industrial.

Current Transducer LF 505-S/SP15

Insulation coordination

U_d	RMS voltage for AC insulation test, 50 Hz, 1 min	3	kV
U_{Ni}	Impulse withstand voltage 1.2/50 μ s	10.6	kV
		Min	
d_{cp}	Creepage distance	18	mm
d_{cl}	Clearance	12.2	mm
CTI	Comparative tracking index (group IIIa)	175	

Applications examples

According to EN 50178 and IEC 61010-1 standards and following conditions:

- Over voltage category OV 3
- Pollution degree PD2
- Non-uniform field

	EN 50178	IEC 61010-1
d_{cp}, d_{cl}, U_{Ni}	Rated insulation voltage	Nominal voltage
Basic insulation	1600 V	1600 V
Reinforced insulation	600 V	600 V

Safety



This transducer must be used in electric/electronic equipment with respect to applicable standards and safety requirements in accordance with the manufacturer's operating instructions.



Caution, risk of electrical shock

When operating the transducer, certain parts of the module can carry hazardous voltage (eg. primary busbar, power supply).

Ignoring this warning can lead to injury and/or cause serious damage.

This transducer is a build-in device, whose conducting parts must be inaccessible after installation.

A protective housing or additional shield could be used.

Main supply must be able to be disconnected.

Dimensions LF 505-S/SP15 (in mm)

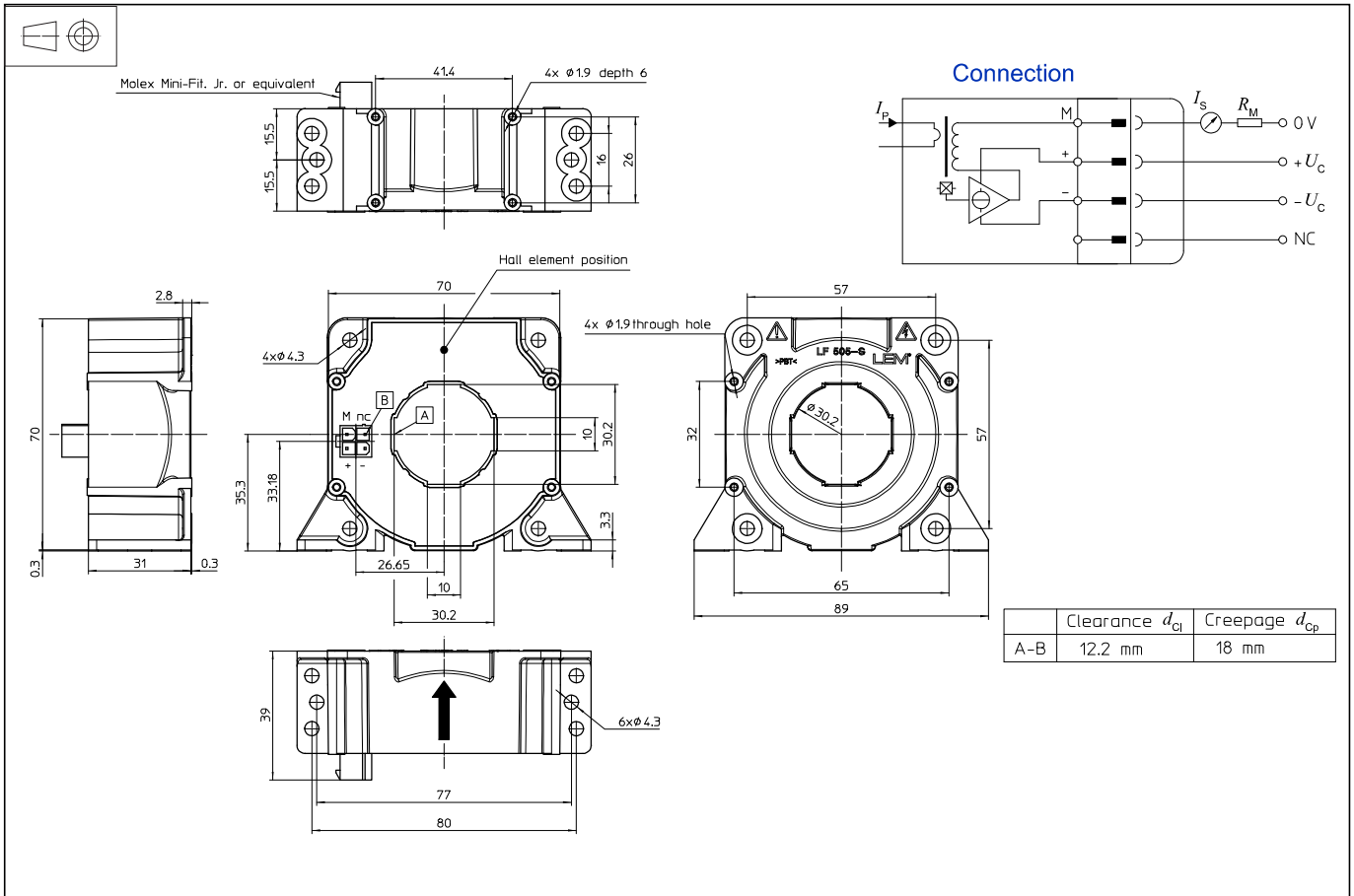

Mechanical characteristics

- General tolerance ± 0.5 mm
- Transducer fastening Vertical position
 - 6 holes $\varnothing 4.3$ mm
 - 6 steel screws M4
- Recommended fastening torque or
 - 3.2 N·m
 - 4 holes $\varnothing 1.9$ mm, depth: 6 mm
 - 4 screws PTKA 25
- Recommended fastening torque Horizontal position
 - 0.7 N·m
 - 4 holes $\varnothing 4.3$ mm,
 - 4 steel screws M4
- Recommended fastening torque or
 - 3.2 N·m
 - 4 holes $\varnothing 1.9$ mm,
 - 4 screws PTKA 25
- Recommended fastening torque
 - 0.75 N·m
- Primary through-hole $\varnothing 30.2$ mm max
- Connection of secondary Molex Mini Fit Jr.
5566 gold-plated pins or equivalent
- Recommended mating connector Molex Mini-Fit Jr.
5557 series.

Remarks

- I_s is positive when I_p flows in the direction of the arrow.
- Temperature of the primary conductor should not exceed 100 °C.
- Installation of the transducer must be done unless otherwise specified on the datasheet, according to LEM Transducer Generic Mounting Rules. Please refer to LEM document N°ANE120504 available on our Web site: <https://www.lem.com/en/file/3137/download>
- Dynamic performances (di/dt and delay time) are best with a single bar completely filling the primary hole.