

Current Transducer IT 1000-S/SP1 ULTRASTAB

$I_{PM} = 1000 A$

For ultra-high precision measurement of current: DC, AC, pulsed..., with galvanic separation between primary and secondary.

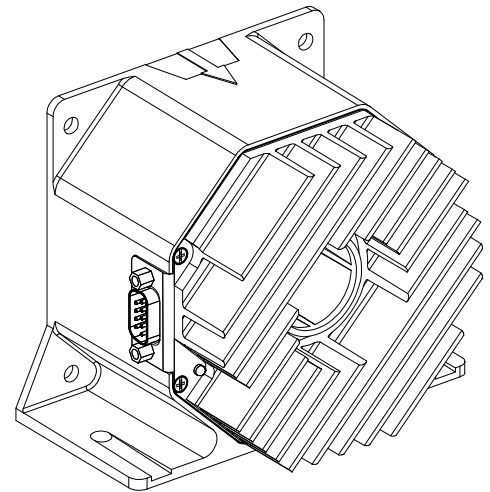

Features

- Closed loop (compensated) current transducer using an extremely accurate zero flux detector
- Electrostatic shield between primary and secondary circuit
- 9-pin D-Sub male secondary connector
- Status signal to indicate the transducer state
- LED indicator confirms normal operation.

Special features

- High current capability
- Bandwidth = DC ... > 500 kHz (± 3 dB).

Advantages

- Very high accuracy
- Excellent linearity
- Extremely low temperature variation
- Wide frequency bandwidth
- High immunity to external fields
- No insertion losses
- High resolution
- Low noise on output signal
- Low noise feedback to primary conductor.

Applications

- Feed back element in high performance gradient amplifiers for MRI
- Feedback element in high-precision, high-stability power supplies
- Calibration unit
- Precise and high stability inverters
- Energy measurement
- Medical equipment.

Standards

- EN 61326-1: 2013
- EN 61000-6-2: 2005 / AC: 2005
- EN 61000-6-3: 2007 / A1: 2011 / AC: 2012
- EN 61010-1: 2010 / A1:2019 / AC: 2019-04
- EN IEC 61010-2-030: 2021 / A11: 2021.

Application Domains

- Industrial
- Medical.

Safety



Caution

If the device is used in a way that is not specified by the manufacturer, the protection provided by the device may be compromised. Always inspect the electronics unit and connecting cable before using this product and do not use it if damaged. Mounting assembly shall guarantee the maximum primary conductor temperature, fulfill clearance and creepage distance, minimize electric and magnetic coupling, and unless otherwise specified can be mounted in any orientation.



Caution, risk of electrical shock

This transducer must be used in limited-energy secondary circuits SELV according to IEC 61010-1, in electric/electronic equipment with respect to applicable standards and safety requirements in accordance with the manufacturer's operating specifications.

Use caution during installation and use of this product; certain parts of the module can carry hazardous voltages and high currents (e.g. power supply, primary conductor).

Ignoring this warning can lead to injury and/or cause serious damage.

De-energize all circuits and hazardous live parts before installing the product.

All installations, maintenance, servicing operations and use must be carried out by trained and qualified personnel practicing applicable safety precautions.

This transducer is a build-in device, whose hazardous live parts must be inaccessible after installation.

This transducer must be mounted in a suitable end-enclosure.

Besides make sure to have a distance of minimum 30 mm between the primary terminals of the transducer and other neighboring components.

Main supply must be able to be disconnected.

Always inspect the current transducer for damage before using this product.

Never connect or disconnect the external power supply while the primary circuit is connected to live parts.

Never connect the output to any equipment with a common mode voltage to earth greater than 30 V.

Always wear protective clothing and gloves if hazardous live parts are present in the installation where the measurement is carried out.

Safe and trouble-free operation of this transducer can only be guaranteed if transport, storage and installation are carried out correctly and are carried out with care.

The current transducer shall not be opened or modified.

If not working, the current transducer shall be replaced by an equivalent device.

This transducer is a built-in device, not intended to be cleaned with any product. Nevertheless if the user must implement cleaning or washing process, validation of the cleaning program has to be done by himself.

Do not dispose of this product as unsorted municipal waste. Contact a qualified recycler for disposal.



Caution, hot surface

Power supply cable must support a temperature of 100 °C at least and it must be fixed in a way to not be in contact with the product housing and primary conductor.

Absolute maximum ratings

Parameter	Symbol	Unit	Value
Maximum supply voltage (working) (10 ... 50 °C)	$\pm U_{C \max}$	V	15.75
Maximum primary conductor temperature	$T_{B \max}$	°C	50

Absolute maximum ratings apply at 25 °C unless otherwise noted.
 Stresses above these ratings may cause permanent damage.
 Exposure to absolute maximum ratings for extended periods may degrade reliability.

Environmental and mechanical characteristics

Parameter	Symbol	Unit	Min	Typ	Max	Comment
Ambient operating temperature	T_A	°C	10		50	
Ambient storage temperature	$T_{A \text{st}}$	°C	-20		85	
Relative humidity	RH	%	20		80	Non-condensing
Mass	m	g		1000		
Altitude		m			2000 ¹⁾	
Environmental conditions						Indoor
Cooling conditions						Natural convection

Note: ¹⁾ Insulation coordination at 2000 m above sea level.

Insulation coordination

Parameter	Symbol	Unit	≤ Value	Comment
RMS voltage for AC insulation test, 50 Hz, 1 min	U_d	kV	3.1	Between primary and secondary + shield
		V DC	200	Between secondary and shield
Impulse withstand voltage 1.2/50 μ s	U_{Ni}	kV	5.7	According to IEC 61010-1
Clearance (pri. - sec.)	d_{Cl}	mm	6	Shortest distance through air
Creepage distance (pri. - sec.)	d_{Cp}	mm	9	Shortest path along device body
Case material	-	-	V0	According to UL 94
Comparative tracking index	CTI		600	
Application example RMS voltage line-to-neutral		V	600	Reinforced insulation according to IEC 61010-1 CAT II, PD2
Application example RMS voltage line-to-neutral		V	300	Reinforced insulation according to EN 50178 CAT III, PD2

If insulated cable is used for the primary circuit, the voltage category could be improved with the following table (for single insulation) (IEC 61010-1 standard):

Cable insulated (primary)	Category
HAR03	450 V CAT III
HAR05	550 V CAT III
HAR07	650 V CAT III

Electrical data

 At $T_A = 25\text{ °C}$, $\pm U_C = \pm 15\text{ V}$, unless otherwise noted (see Min, Max, typ, definition paragraph in [page 6](#)).

Parameter	Symbol	Unit	Min	Typ	Max	Comment
Primary nominal DC current (continuous)	I_{PNDC}	A			1000	
Primary nominal AC RMS current (continuous)	I_{PNAC}	A			707	
Primary current, measuring range	I_{PM}	A	-1000		1000	
Measuring resistance	R_M	Ω	0		3	$U_C = \pm 15\text{ V} \pm 5\%$, $T_A = 10\text{ °C} \dots 50\text{ °C}$, $I_P = 0 \dots \pm I_{PM}$, See page 7
Secondary current	I_S	mA	-1000		1000	
Maximum withstand primary peak current ¹⁾	\hat{I}_{Pmax}	kA	-4		4	@ pulse of 100 ms
Resistance of secondary winding	R_S	Ω		6		@ 25 °C
Number of secondary turns	N_S			1000		
DC supply voltage	U_C	V	± 14.25	± 15	± 15.75	
DC current consumption	I_C	mA			80	Add I_S for total current consumption
Electrical offset current + self magnetization + effect of earth magnetic field ²⁾	I_{OE}	ppm	-50		50	
Temperature coefficient of I_{OE} referred to primary ²⁾	TCl_{OE}	ppm/K			0.5	$T_A = 10\text{ °C} \dots 50\text{ °C}$
Offset stability ²⁾		ppm/month			0.5	
Sensitivity	S	mA/A		1		
Linearity error ²⁾	ϵ_L	ppm			3	
RMS noise current 0 ... 10 Hz referred to primary ²⁾	I_{no}	ppm			0.05	
RMS noise current 0 ... 10 kHz referred to primary ²⁾					3	
RMS noise current 0 ... 50 kHz referred to primary ²⁾					6	
Re-injected RMS noise on primary bus bar		μV			5	0 ... 50 kHz
Delay time to 90 % of the final output value for I_{PN} step ³⁾	t_{D90}	μs			1	di/dt of 100 A/ μs
Frequency bandwidth ($\pm 3\text{ dB}$)	BW	kHz	0	500		Small-signal bandwidth, 0.5 % of I_{PM}

- Notes:**
- 1) Single pulse only, not AC. The transducer may require a few seconds to return to normal operation when autoreset system is running.
 - 2) All ppm figures refer to full-scale which corresponds to a secondary current (I_S) of 1000 mA.
 - 3) For a $di/dt = 100\text{ A}/\mu\text{s}$, accurately followed.

Definition of typical, minimum and maximum values

Minimum and maximum values for specified limiting and safety conditions have to be understood as such as well as values shown in “typical” graphs.

On the other hand, measured values are part of a statistical distribution that can be specified by an interval with upper and lower limits and a probability for measured values to lie within this interval.

Unless otherwise stated (e.g. “100 % tested”), the LEM definition for such intervals designated with “min” and “max” is that the probability for values of samples to lie in this interval is 99.73 %.

For a normal (Gaussian) distribution, this corresponds to an interval between -3 sigma and $+3$ sigma. If “typical” values are not obviously mean or average values, those values are defined to delimit intervals with a probability of 68.27 %, corresponding to an interval between $-\text{sigma}$ and $+\text{sigma}$ for a normal distribution.

Typical, maximal and minimal values are determined during the initial characterization of the product.

Overload protection - Electrical specification - Status

The overload occurs when the primary current I_p exceeds a trip level such that the fluxgate detector becomes completely saturated and, consequently, the transducer will switch from normal operation to overload mode. This trip level is guaranteed to be greater than 110 % of $I_{PND C}$ and its actual value depends on operating conditions such as temperature and measuring resistance.

Under these conditions:

- The contact (normal operation status) between pin 3 and 8 (of the D-sub connector) switches off, this contact becomes open.
- The green LED indicator (normal operation status) turns off.

Max voltage pin 3 and pin 8, off-State	45 V
Max current pin 3 and pin 8, on-State	30 mA
On-State resistance pin 3 and pin 8:	50 mΩ (typ)

To maintain safe start-up R_M must not exceed 3 Ω during fault condition. The Overcurrent mode remains until the primary current decreases to a value lower than the recovery current.

Maximum measuring resistor versus secondary current

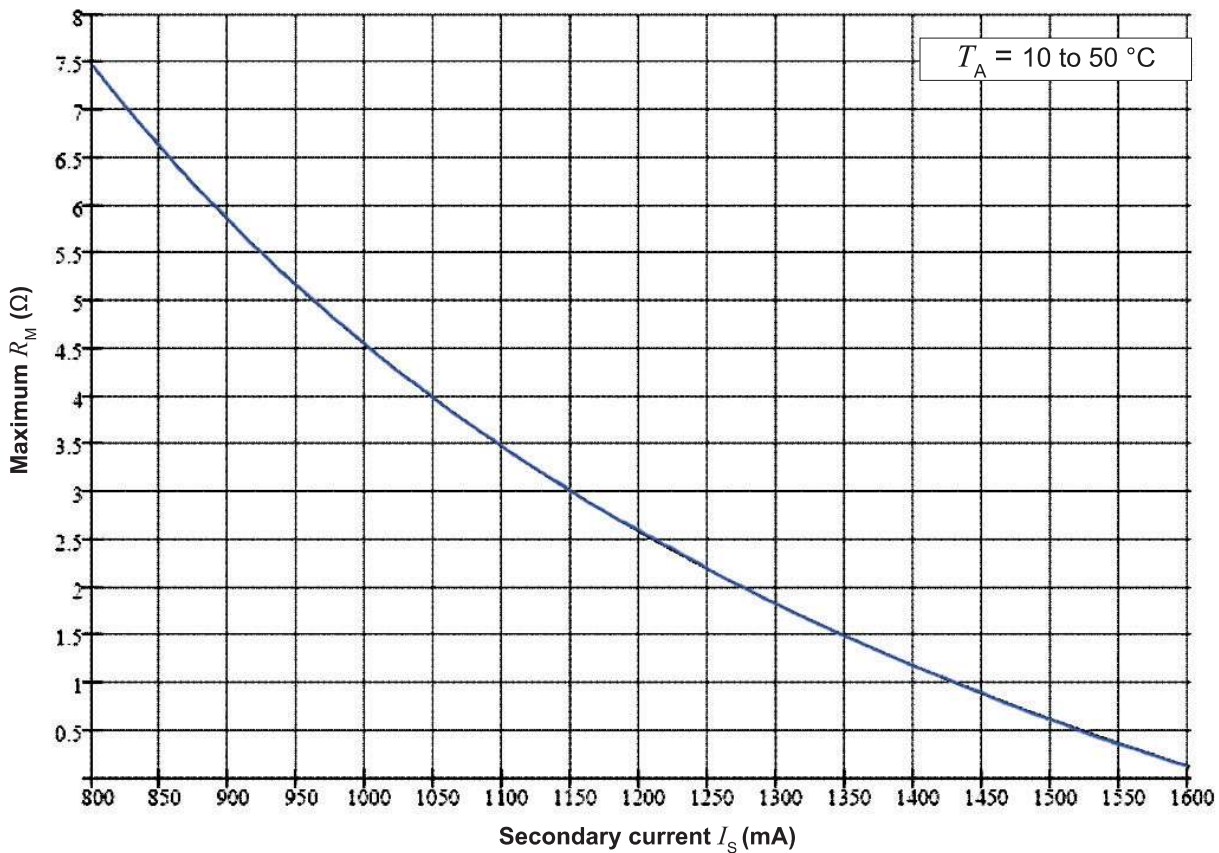

Status/Interlock port wiring

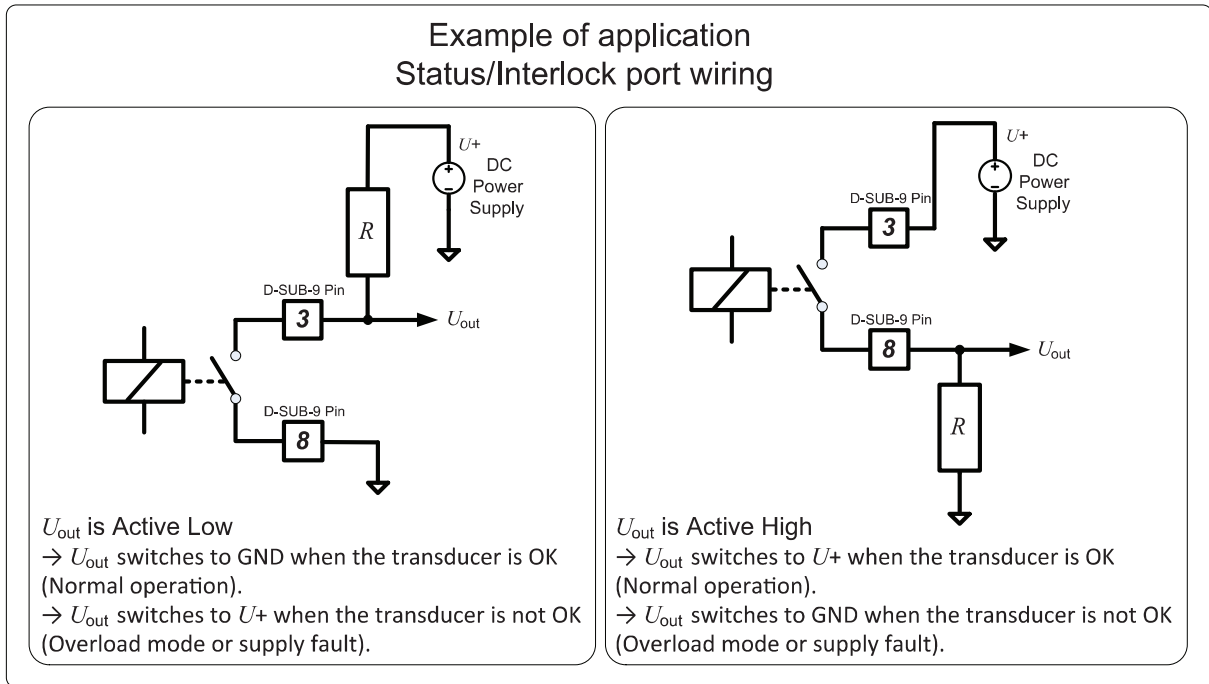

Circuit diagram for using $R_M > 3 \Omega$

This circuit ensures a safe recovery from saturation when using $R_M > 3 \Omega$. It allows the transducer to recover normal operation in case R_M is greater than 3Ω and an overload is detected by the transducer.

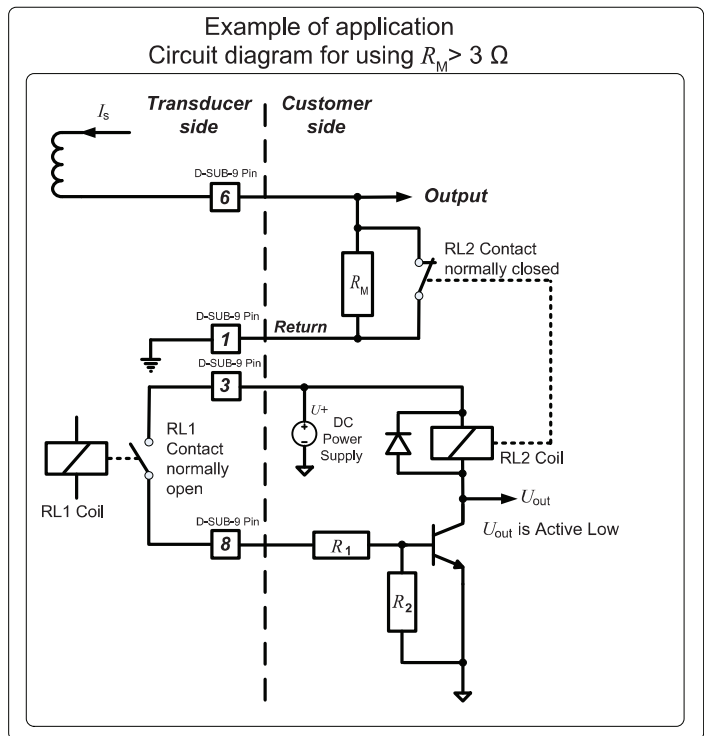

Contact RL1 (Pins 3 and 8)	Contact RL2	U_{out}	Description
Closed	Open	Low (switches to GND)	The transducer is OK (Normal operation)
Open	Closed	High (switches to $U+$)	The transducer is not OK (Overload mode or supply fault)

Performance parameters definition

The schematic used to measure all electrical parameters is shown below:

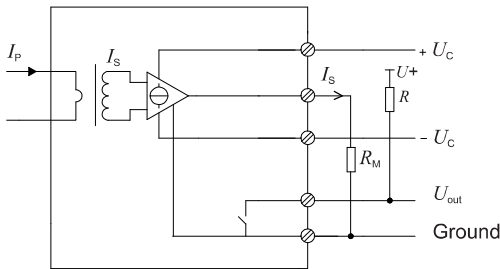

Transducer simplified model

The static model of the transducer at temperature T_A is:

$$I_s = N_p/N_s \cdot I_p + \varepsilon$$

In which

$$\varepsilon = I_{OE} \text{ at } 25^\circ\text{C} + I_{OT}(T_A) + \varepsilon_L \cdot I_{PM} \cdot N_p/N_s$$

Where,

$$I_{OT}(T_A) = TCI_{OE} \cdot |T_A - 25^\circ\text{C}| \cdot I_{PM} \cdot N_p/N_s$$

- I_s : secondary current (A)
- N_p/N_s : turns ratio (1: N_s)
- I_p : primary current (A)
- I_{PM} : primary current, measuring range (A)
- T_A : ambient operating temperature ($^\circ\text{C}$)
- I_{OE} : electrical offset current (A)
- I_{OT} : temperature variation of I_{OE} at T_A (A)
- ε_L : linearity error

This is the absolute maximum error. As all errors are independent, a more realistic way to calculate the error would be to use the following formula:

$$\varepsilon = \sqrt{\sum_{i=1}^N \varepsilon_i^2}$$

Linearity

To measure linearity, the primary current (DC) is cycled from 0 to I_p , then to $-I_p$ and back to 0 (equally spaced $I_p/10$ steps). The linearity error ε_L is the maximum positive or negative difference between the measured points and the linear regression line, expressed in parts per million (ppm) of full-scale which corresponds to the maximum measured value.

Electrical offset

The electrical offset current I_{OE} is the residual output current when the input current is zero.

The temperature variation I_{OT} of the electrical offset current I_{OE} is the variation of the electrical offset from 25°C to the considered temperature.

Delay time

The delay time t_{D90} with respect to the primary are shown in the next figure. It slightly depends on the primary current di/dt . It is measured at nominal current.

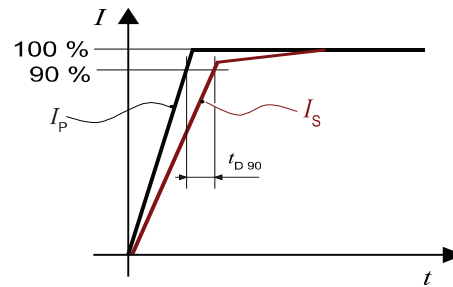

t_{D90} (delay time @ 90 %)

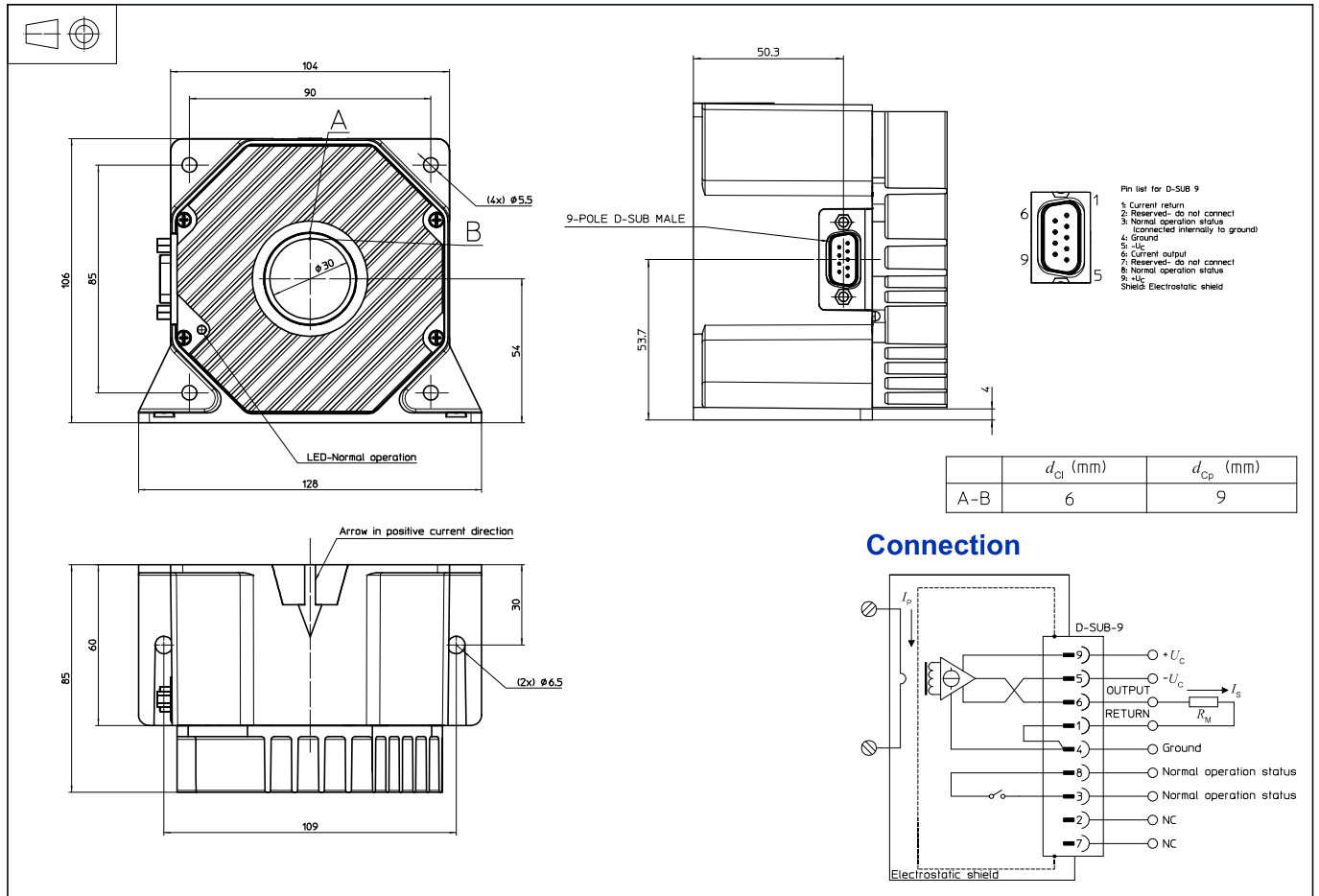
Dimensions (in mm)

Connection

- Normal operation status (Pins 3 and 8)
Normal operation means:
 - $\pm 15\text{ V}$ ($\pm U_C$) present
 - zero detector is working
 - compensation current $\leq 110\%$ of I_{PNDC}
 - green LED indicator is lit.

Contact (Pins 3 and 8)	Description
Closed	The transducer is OK (Normal operation)
Open	The transducer is not OK (Overload mode or supply fault)

Remarks

- I_s is positive when I_p flows in the direction of arrow
- The secondary cables also have to be routed together all the way
- Pin 4 should be connected to cable and connector shield to maintain lowest output noise
- Maximum temperature of the primary conductor: see [page 3](#)
- Installation of the transducer must be done unless otherwise specified on the datasheet, according to LEM Transducer Generic Mounting Rules. Please refer to LEM document N°ANE120504 available on our Web site: <https://www.lem.com/en/file/3137>

Mechanical characteristics

- General tolerance $\pm 0.5\text{ mm}$
- Transducer fastening
 - Straight mounting: 2 holes $\phi 6.5\text{ mm}$, 2 x M6 steel screws, Recommended fastening torque 4.4 N·m
 - Flat mounting: 4 holes $\phi 5.5\text{ mm}$, 4 x M5 steel screws, Recommended fastening torque 3.7 N·m
- Connection of secondary on D-SUB-9, connector UNC 4-40
- Primary through hole $\phi \leq 30\text{ mm}$
- All mounting recommendations are given for a standard mounting. Screws with flat and spring washers.