

Voltage Transducer CV 4-6000/SP2

For the electronic measurement of voltages: DC, AC, pulsed..., with galvanic separation between the primary circuit and the secondary circuit.

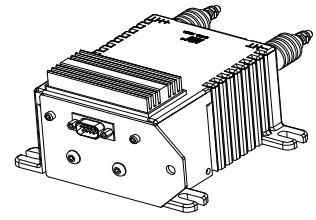

$$U_{PN} = 4200 \text{ V}$$



Features

- Closed loop (compensated) voltage transducer
- Insulating plastic case recognized according to UL 94-V0.

Special features

- $U_C = \pm 24 (\pm 10 \%) \text{ V}$
- $T_A = -40 \text{ }^\circ\text{C} \dots +70 \text{ }^\circ\text{C}$
- Shield
- Connection to secondary circuit on SUB-D 9 poles, male.

Advantages

- Excellent accuracy
- Very good linearity
- Low temperature drift
- Optimized response time
- Wide frequency bandwidth
- No insertion losses
- High immunity to external interference
- Current overload capability.

Applications

- AC variable speed drives and servo motor drives
- Static converters for DC motor drives
- Uninterruptible Power Supplies (UPS)
- Power supplies for welding applications
- Railway overhead line voltage measurement
- Single or three phase inverters
- Propulsion and braking choppers
- Propulsion converters
- Auxiliary converters
- Battery chargers.

Application Domains

- Railway (fixed installations and onboard)
- Industrial.

Electrical data

| | | | |
|----------|--|------------------|------------|
| U_{PN} | Primary nominal RMS voltage | 4200 | V |
| U_{PM} | Primary voltage, measuring range | 0 ... ± 6000 | V |
| U_S | Secondary analog voltage @ U_{Pmax} | 10 | V |
| S | Sensitivity | 6000 V / 10 V | |
| R_L | Load resistance | ≥ 2 | k Ω |
| C_L | Load capacitance | ≤ 5 | nF |
| U_C | Supply voltage ($\pm 10 \%$) | ± 24 | V |
| I_C | Current consumption @ $U_C = \pm 24 \text{ V}$ | $35 + U_S / R_L$ | mA |

Accuracy - Dynamic performance data

| | | | Max | |
|---------------------|--|--------------|-----|---------------|
| ε_{tot} | Total error @ $U_{PN}, T_A = 25 \text{ }^\circ\text{C}$ | ± 0.4 | | % |
| | -40 $^\circ\text{C}$... +70 $^\circ\text{C}$ | ± 1.0 | | % |
| U_O | Offset voltage @ $U_P = 0, T_A = 25 \text{ }^\circ\text{C}$ | ± 20 | | mV |
| | -40 $^\circ\text{C}$... +70 $^\circ\text{C}$ | ± 60 | | mV |
| t_{D90} | Delay time to 90 % of the final output value for I_{PN} step ¹⁾ | ≈ 50 | | μs |
| BW | Frequency bandwidth (-3 dB) @ 50 % U_{PN} | DC ... 6kHz | | |

General data

| | | | |
|-----------|---------------------------------|--|------------------|
| T_A | Ambient operating temperature | -40 ... +70 | $^\circ\text{C}$ |
| T_{Ast} | Ambient storage temperature | -50 ... +85 | $^\circ\text{C}$ |
| P_P | Total primary power loss | 4.2 | W |
| R_P | Resistance of primary (winding) | 4.2 | M Ω |
| m | Mass | 750 | g |
| | Standards | EN 50155: 2007 EN 50178: 1997 EN 50121-3-2: 2016 ²⁾ | |

Notes: ¹⁾ For a $dv/dt = 1000 \text{ V}/\mu\text{s}$.

²⁾ Deviation of the offset during the test IEC 61000-4-3 between 100 to 300 MHz.

Voltage Transducer CV 4-6000/SP2

Insulation coordination

| | | | |
|----------|---|-------------------|----|
| U_d | RMS voltage for AC insulation test, 50 Hz, 1 min | 9.5 ¹⁾ | kV |
| U_t | Partial discharge RMS test voltage ($q_m < 10$ pC) | 3.75 | kV |
| | | Min | |
| d_{cp} | Creepage distance | 185.1 | mm |
| d_{cl} | Clearance | 118.5 | mm |
| CTI | Comparative tracking index (group I) | 600 | |

Note: ¹⁾ Between primary and secondary + shield.

Applications examples

According to EN 50178 and IEC 61010-1 standards and following conditions:

- Over voltage category OV 3
- Pollution degree PD2
- Non-uniform field

| | EN 50178 | IEC 61010-1 |
|--------------------------|--------------------------|-----------------|
| d_{cp}, d_{cl}, U_{Ni} | Rated insulation voltage | Nominal voltage |
| Basic insulation | 8000 V | 1000 V |
| Reinforced insulation | 5600 V | 1000 V |

Safety

This transducer must be used in limited-energy secondary circuits according to IEC 61010-1.



This transducer must be used in electric/electronic equipment with respect to applicable standards and safety requirements in accordance with the manufacturer's operating instructions.



Caution, risk of electrical shock

When operating the transducer, certain parts of the module can carry hazardous voltage (e.g. primary connections, power supply).

Ignoring this warning can lead to injury and/or cause serious damage.

This transducer is a build-in device, whose conducting parts must be inaccessible after installation.

A protective housing or additional shield could be used.

Main supply must be able to be disconnected.

Dimensions CV 4-6000/SP2 (in mm)

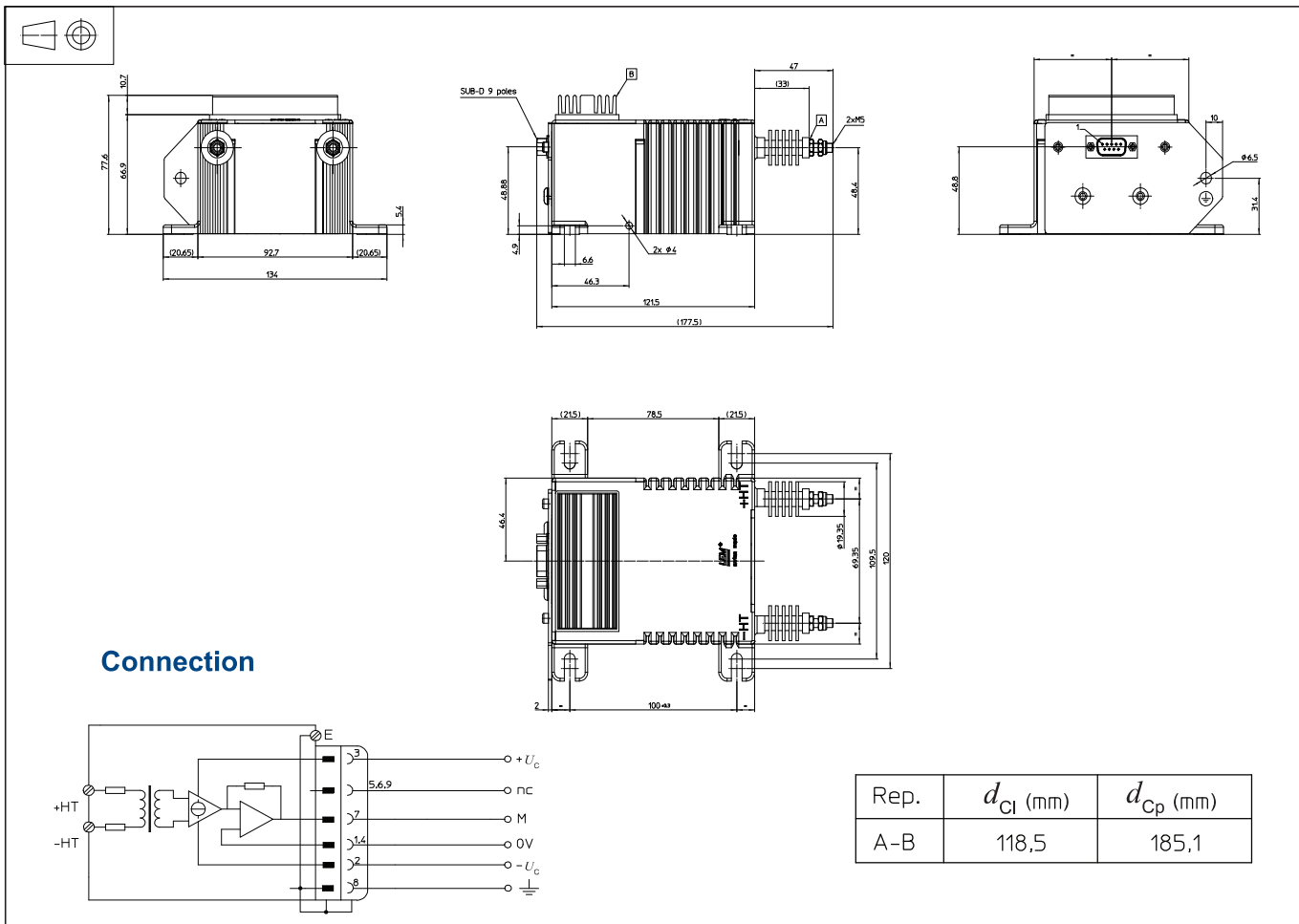

Mechanical characteristics

- General tolerance ± 0.5 mm
- Transducer fastening
 - 4 slots $\varnothing 6.6$ mm
 - 4 M6 steel screws
 - Recommended fastening torque 5 N·m
- Connection of primary
 - M5 threaded studs
 - Recommended fastening torque 2.2 N·m
- Connection of secondary SUB-D 9 poles, male
- Connection to the ground hole $\varnothing 6.5$ mm

Remarks

- U_s is positive when U_p is applied on terminal +HT.
- Installation of the transducer must be done unless otherwise specified on the datasheet, according to LEM Transducer Generic Mounting Rules. Please refer to LEM document N°ANE120504 available on our Web site: <https://www.lem.com/en/file/3137/download/>.