

# Voltage Transducer LV 100-600

For the electronic measurement of voltages: DC, AC, pulsed..., with galvanic separation between the primary circuit and the secondary circuit.



$$U_{PN} = 600 \text{ V}$$



## Features

- Closed loop (compensated) voltage transducer using the Hall effect
- Insulating plastic case recognized according to UL 94-V0
- Primary resistor – incorporated within the housing.

## Advantages

- Excellent accuracy
- Very good linearity
- Low temperature drift
- Optimized delay time
- Wide frequency bandwidth
- No insertion losses
- High immunity to external interference.

## Applications

- AC variable speed drives and servo motor drives
- Static converters for DC motor drives
- Uninterruptible Power Supplies (UPS)
- Power supplies for welding applications.

## Application Domain

- Industrial.

### Electrical data

$U_{PN}$	Primary nominal RMS voltage	600	V
$U_{PM}$	Primary voltage, measuring range	0 ... ±900	V
$I_{PN}$	Primary nominal RMS current	16.66	mA
$R_M$	Measuring resistance with ±15 V	@ ±600 V <sub>max</sub>	$R_{Mmin}$ 0 $R_{Mmax}$ 210    Ω
		@ ±900 V <sub>max</sub>	0    120    Ω
$I_{SN}$	Secondary nominal RMS current	50	mA
$S$	Sensitivity	83.33	µA/V
$U_C$	Supply voltage (±5 %)	±15	V
$I_C$	Current consumption	< 32 + $I_S$	mA

### Accuracy - Dynamic performance data

$\epsilon_{tot}$	Total error @ $U_{PN}, T_A = 25 \text{ °C}$	±0.9	%
$\epsilon_L$	Linearity error	< 0.1	%
$I_O$	Offset current @ $U_p = 0, T_A = 25 \text{ °C}$	Typ	±0.2    mA
		Max	±0.2    mA
$I_{OT}$	Temperature variation of $I_O$ 0 °C ... +70 °C	±0.2	±0.3    mA
$t_{D90}$	Delay time to 90 % of the final output value for $U_{PN}$ step	< 90	µs

### General data

$T_A$	Ambient operating temperature	0 ... +70	°C
$T_{Ast}$	Ambient storage temperature	-25 ... +85	°C
$N_P/N_S$	Turns ratio	6000 : 2000	
$P_P$	Total primary power loss	10	W
$R_P$	Resistance of primary winding @ $T_A = 25 \text{ °C}$	36	kΩ
$R_S$	Resistance of secondary winding @ $T_A = 70 \text{ °C}$	55	Ω
$m$	Mass	790	g
	Standard	EN 50178: 1997	

## Voltage Transducer LV 100-600

### Insulation coordination

$U_d$	RMS voltage for AC insulation test, 50 Hz, 1 min	6	kV
$U_{Ni}$	Impulse withstand voltage 1.2/50 $\mu$ s	8	kV
		Min	
$d_{Cp}$	Creepage distance	55.12	mm
$d_{Cl}$	Clearance	27.9	mm
$CTI$	Comparative tracking index (group I)	600	

### Applications examples

According to EN 50178 and IEC 61010-1 standards and following conditions:

- Over voltage category OV 3
- Pollution degree PD2
- Non-uniform field

	EN 50178	IEC 61010-1
$d_{Cp}, d_{Cl}, U_{Ni}$	Rated insulation voltage	Nominal voltage
Basic insulation	1000 V	1000 V
Reinforced insulation	600 V	300 V

### Safety

This transducer must be used in limited-energy secondary circuits according to IEC 61010-1.



This transducer must be used in electric/electronic equipment with respect to applicable standards and safety requirements in accordance with the manufacturer's operating instructions.



Caution, risk of electrical shock

When operating the transducer, certain parts of the module can carry hazardous voltage (e.g. primary busbar, power supply). Ignoring this warning can lead to injury and/or cause serious damage.

This transducer is a build-in device, whose conducting parts must be inaccessible after installation. A protective housing or additional shield could be used.

Main supply must be able to be disconnected.

## Dimensions LV 100-600 (in mm)

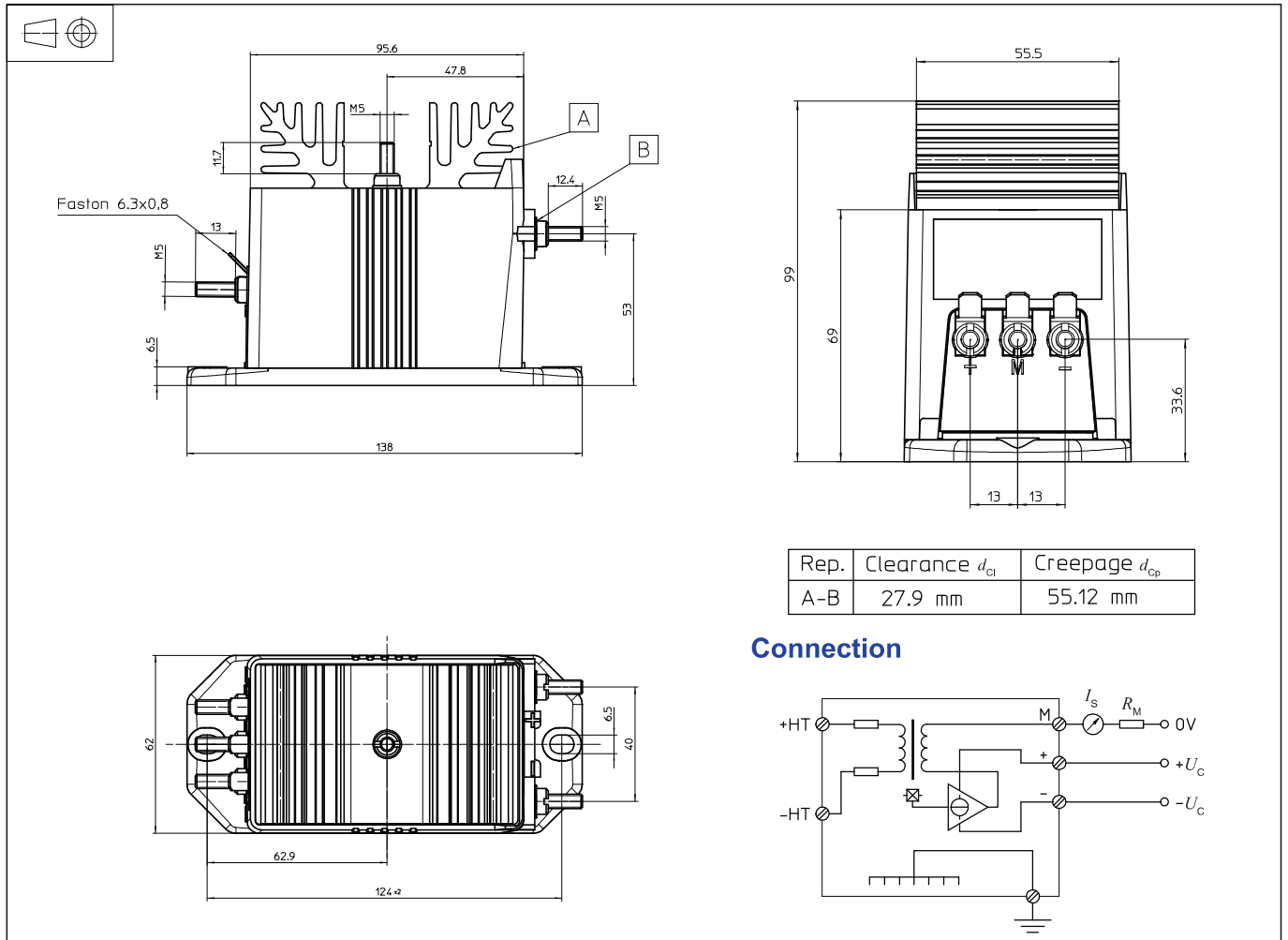

### Mechanical characteristics

- General tolerance  $\pm 0.5$  mm
- Transducer fastening
  - 2 holes  $\varnothing 6.5$  mm
  - 2 M6 steel screws
- Recommended fastening torque 5 N·m
- Connection of primary
  - M5 threaded studs
  - Recommended fastening torque 2.2 N·m
- Connection of secondary
  - Faston 6.3 × 0.8 mm
- Connection of ground
  - M5 threaded stud
  - Recommended fastening torque 2.2 N·m

### Remarks

- $I_s$  is positive when  $U_p$  is applied on terminal +HT.
- The primary circuit of the transducer must be linked to the connections where the voltage has to be measured.
- Installation of the transducer must be done unless otherwise specified on the datasheet, according to LEM Transducer Generic Mounting Rules. Please refer to LEM document N°ANE120504 available on our Web site: <https://www.lem.com/en/file/3137/download/>.
- This is a standard model. For different versions (supply voltages, turns ratios, unidirectional measurements...), please contact us.