

Voltage Transducer LV 100-1200

For the electronic measurement of voltages: DC, AC, pulsed..., with galvanic separation between the primary circuit and the secondary circuit.



$$U_{PN} = 1200 \text{ V}$$



Features

- Closed loop (compensated) voltage transducer using the Hall effect
- Insulating plastic case recognized according to UL 94-V0
- Primary resistor – incorporated within the housing.

Advantages

- Excellent accuracy
- Very good linearity
- Low temperature drift
- Optimized delay time
- Wide frequency bandwidth
- High immunity to external interference.

Applications

- AC variable speed drives and servo motor drives
- Static converters for DC motor drives
- Battery supplied applications
- Uninterruptible Power Supplies (UPS)
- Switched Mode Power Supplies (SMPS)
- Power supplies for welding applications.

Application Domain

- Industrial.

Electrical data

U_{PN}	Primary nominal RMS voltage	1200	V
U_{PM}	Primary voltage, measuring range	0 ... ±1800	V
I_{PN}	Primary nominal RMS current	8.33	mA
R_M	Measuring resistance with ±15 V	@ ±1200 V _{max}	$R_{M \min}$ 0 $R_{M \max}$ 210 Ω
		@ ±1800 V _{max}	0 125 Ω
I_{SN}	Secondary nominal RMS current	50	mA
S	Sensitivity	41.667	µA/V
U_C	Supply voltage (±5 %)	±15	V
I_C	Current consumption	< 32 + I_S	mA

Accuracy - Dynamic performance data

ϵ_{tot}	Total error @ $U_{PN}, T_A = 25 \text{ °C}$	±0.9	%
ϵ_L	Linearity error	< 0.1	%
I_O	Offset current @ $I_P = 0, T_A = 25 \text{ °C}$	Typ	±0.2 mA
		Max	±0.2 mA
I_{OT}	Temperature variation of I_O 0 °C ... +70 °C	±0.2	±0.3 mA
t_{D90}	Delay time to 90 % of the final output value for U_{PN} step	< 120	µs

General data

T_A	Ambient operating temperature	0 ... +70	°C
T_{Ast}	Ambient storage temperature	-25 ... +85	°C
N_P	Number of primary turns	12000 : 2000	
P_P	Total primary power loss	10	W
R_P	Resistance of primary winding @ $T_A = 25 \text{ °C}$	144	kΩ
R_S	Resistance of secondary winding @ $T_A = 70 \text{ °C}$	55	Ω
m	Mass	790	g
	Standard	EN 50178: 1997	

Voltage Transducer LV 100-1200

Insulation coordination

U_d	RMS voltage for AC insulation test, 50 Hz, 1 min	6	kV
U_{Ni}	Impulse withstand voltage 1.2/50 μ s	12.8	kV
		Min	
d_{Cp}	Creepage distance	55.12	mm
d_{Cl}	Clearance	27.9	mm
CTI	Comparative tracking index (group I)	600	

Applications examples

According to **EN 50178** and **IEC 61010-1** standards and following conditions:

- Over voltage category OV 3
- Pollution degree PD2

	EN 50178	IEC 61010-1
d_{Cp}, d_{Cl}, U_{Ni}	Rated insulation voltage	Nominal voltage
Basic insulation	1200 V	1000 V
Reinforced insulation	1200 V	1000 V

Safety

This transducer must be used in limited-energy secondary circuits according to IEC 61010-1.



This transducer must be used in electric/electronic equipment with respect to applicable standards and safety requirements in accordance with the manufacturer's operating instructions.



Caution, risk of electrical shock

When operating the transducer, certain parts of the module can carry hazardous voltage (e.g. primary busbar, power supply). Ignoring this warning can lead to injury and/or cause serious damage.

This transducer is a build-in device, whose conducting parts must be inaccessible after installation. A protective housing or additional shield could be used.

Main supply must be able to be disconnected.

Dimensions LV 100-1200 (in mm)

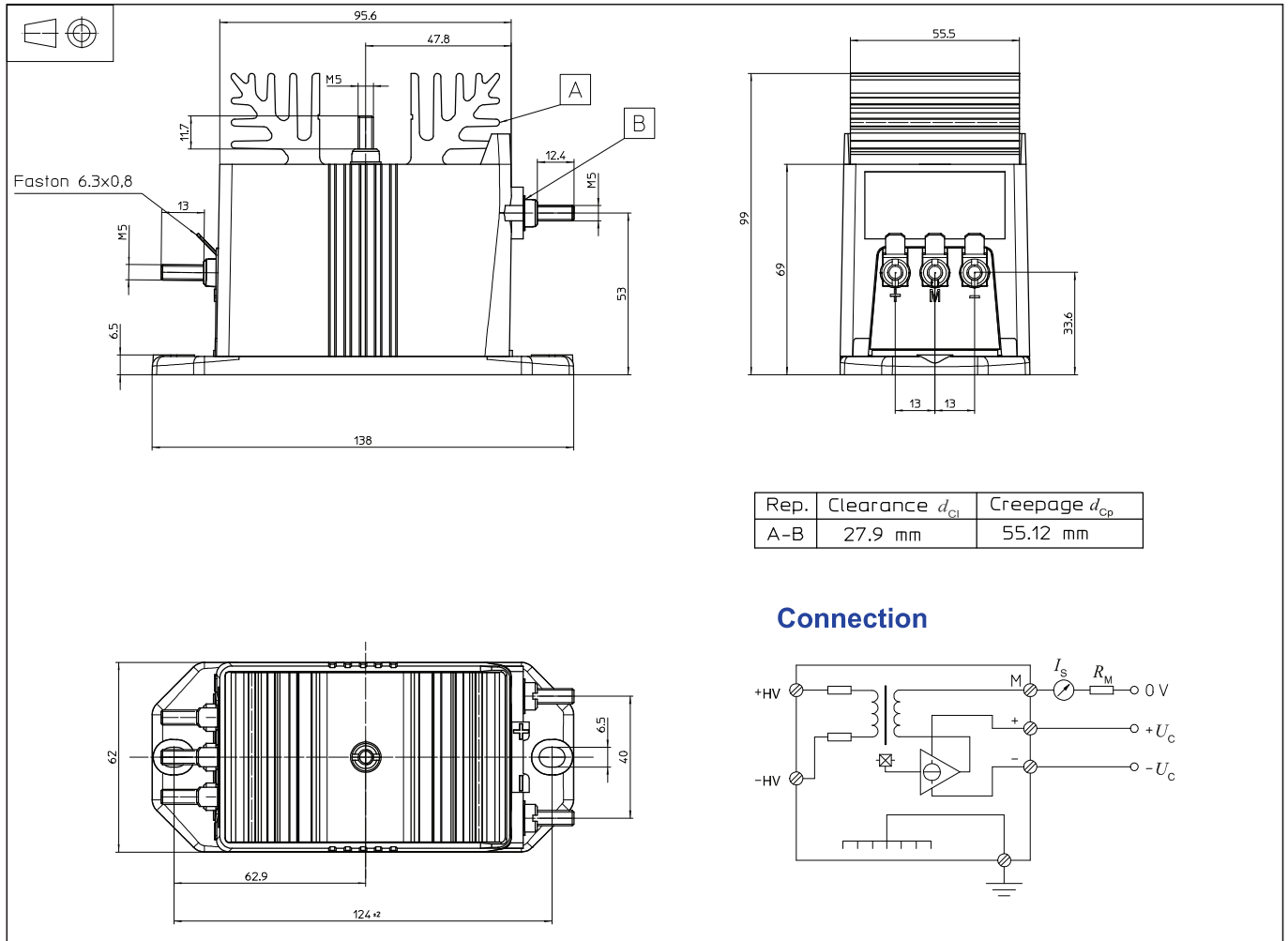

Connection

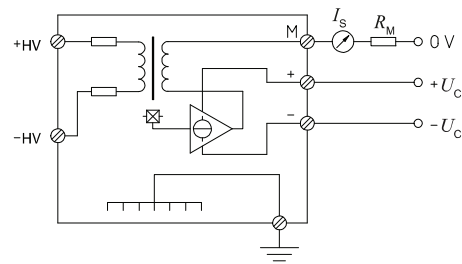

Mechanical characteristics

- General tolerance ± 0.5 mm
- Transducer fastening
 - 2 holes $\varnothing 6.5$ mm
 - 2 M6 steel screws
 - Recommended fastening torque 5 N·m
- Connection of primary
 - M5 threaded studs
 - Recommended fastening torque 2.2 N·m
- Connection of secondary
 - Faston 6.3 × 0.8 mm
- Connection of ground
 - M5 threaded stud
 - Recommended fastening torque 2.2 N·m

Remarks

- I_S is positive when U_p is applied on terminal +HV.
- The primary circuit of the transducer must be linked to the connections where the voltage has to be measured.
- Installation of the transducer must be done unless otherwise specified on the datasheet, according to LEM Transducer Generic Mounting Rules. Please refer to LEM document N°ANE120504 available on our Web site: <https://www.lem.com/en/file/3137/download/>.
- This is a standard model. For different versions (supply voltages, turns ratios, unidirectional measurements...), please contact us.