

Series 400 Autovalve

Instructions / Parts Lists

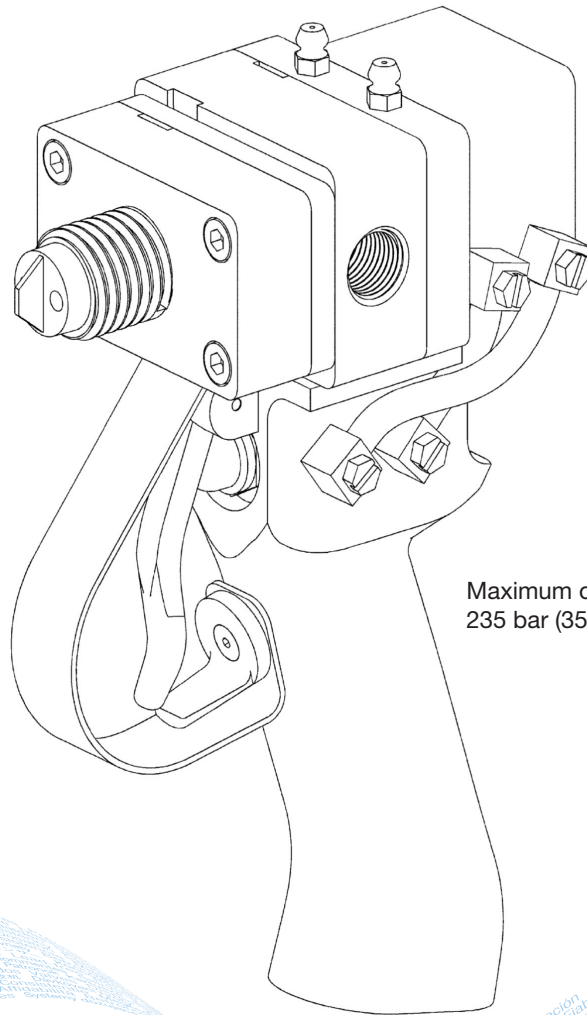

Maximum operating pressure
235 bar (3500 psi)

Contents

Contents	2
Operation.....	3
Installation	3
Connect Supply Lines.....	3
Startup	3
Maintenance.....	4
Disassembly and Cleaning	4
Rebuilding the Autovalve	4
Final QC Check.....	4
Manifolds for Series 160 Disposable Mixers	6
Mount	7
Hand Held with Pneumatic Switch #7701977	7
Hand Held – Electric Momentary Switch (24 Volt) #7701971	8
Air Cylinders – Single Hardened SS Shafts #7702315	9
Air Cylinders – Double	9
Spare Parts Kits.....	10
Accessories	11
Fluid Inlet Adapter for 400 Valve.....	11
Ratio Check Cap.....	12
Night Cap.....	12
Troubleshooting.....	13

Operation

The ON-OFF operation of the valve is controlled by movement of the piston inside the air cylinder (1). In the OFF position, the piston advances and the front seal (13) seats into the seat plate (8).

In the ON position, the piston and seals retract from the seat plate (8), which allows A & B fluids to pass through the manifold.

A disposable Series 160 mixer can be attached to the manifold. If the operating pressure exceeds 10 bar (150 psi), we recommend a metal jacket be used over the plastic mix tube.

NOTE: For all reference numbers in parenthesis, see pages 5–9.

Your 400 AUTOVALVE in general...

- Designed to dispense two-component adhesives and sealants
- Dispenses low or high viscosity urethanes, epoxies and silicones
- Can be mounted for beads or timed shots; optional handle is available for hand held applications
- Provides an ON-OFF function. The metering of the adhesives in the proper ratio of A:B is controlled by the metering pumps.

Installation

Connect Supply Lines

The A & B fluid hoses are connected to the side of the valve body (7), between the valve and the pumps, and should be as short as possible. It is a good practice to install check valves in the hoses just before the valve. Optional fitting with check valve is listed on page 11.

For stationary mount, the air lines will be connected to the side of the air cylinder (1). Air to the back of the cylinder to close and air to the front to open. If the optional handle is used, air is connected to the barbed fitting (105) on the side of the handle.

The air line should have minimum pressure of 5.5 bar (80 psi).

Startup

1. With the hand-held model, start metering pumps and purge the air out of the A & B hoses and Autovalve. After the A and B fluids come out of the manifold, attach a mixer to the manifold and hold the valve upside down with the mixer pointing up. Dispensing A & B will purge the last pockets of air in the valve body.

A stationary mount or gantry installation requires a swivel mounting bracket. To complete purging, turn the valve with the mixer pointing up and dispense A & B.

2. Take a ratio check by weight of A:B after the manifold. The Autovalve does **No Metering**. The Volume Ratio of A:B is controlled by the metering pumps. However, between the metering pumps and the Autovalve are hoses. These hoses will expand under pressure and cause lead-lag problems. Lead-lag refers to the uneven starting of the A fluid before the B fluid. Nordson EFD offers 1:1 and wide ratio manifolds to reduce this problem. The selection of the correct manifold depends on both the volume and viscosity ratio of A and B.

Consult EFD Technical Services for details at 800-556-3484.

Maintenance

Disassembly and Cleaning

1. Remove the manifold and seat plate (8). Pry bar slots are provided.
2. Remove the air cylinder bolts (2) and wiggle the air cylinder apart. If the assembly is frozen, use the pry bar slots on the valve body (7) to separate the valve body (7) from the tie plate (5). Insert flat pieces of metal between the valve body and the tie plate as per Figure 1. Thread the manifold screws (36) into the back of the tie plate and push the valve body apart. Apply uniform pressure to prevent the body from cocking and bending the air cylinder shafts (75).
3. Once apart, the parts should be cleaned. We recommend overnight soaking in suitable solvent. All parts can be soaked except the handle and air cylinder.

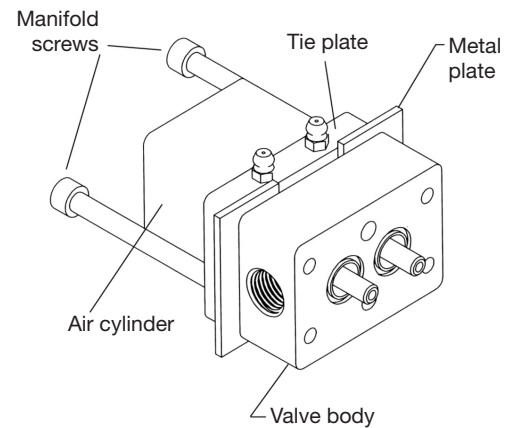

Figure 1

Rebuilding the Autovalve

1. After cleaning, inspect the following components:
 - a. Seat plate (8) on sealing surface
 - b. Manually retract and extend the shafts (75) from air cylinder (1).
 - c. If the optional handle is used, connect air into the inlet and check 4-way action of cartridge valve (103).
2. Refer to page 10 for a repair kit which contains lip seals, O-rings, and front seals.
3. Lubricate lip seals (3) and shafts (75) with auto grease (read SDS prior to use).
4. Insert four back lip seals (3): two into tie plate (5) and two into the valve body (7). The lip seals are two pieces: an O-ring and a U-cup. They should always be installed with the O-ring facing the material inlets (body of the valve).
5. Push the air cylinder (1) thru the tie plate (5) and the valve body (7) and engage the screws (2).
6. Push front seal (13) and washer (12) onto adjustment screw (14). To prevent binding, apply auto grease to the threads on the adjustment screws (14). Thread the seal and adjustment screw assembly into air cylinder shafts.
7. Assemble the seat plate (8) onto the valve body (7).

Final QC Check

Before the manifold is assembled, we recommend air be connected to the air cylinder (1) and the open / close function of the front seals (13) be inspected for leakage.

The front seals could flow into the proper shape as the valve is used. It may be necessary to pressurize the air cylinder, but not the A & B fluids.

Maintenance (continued)

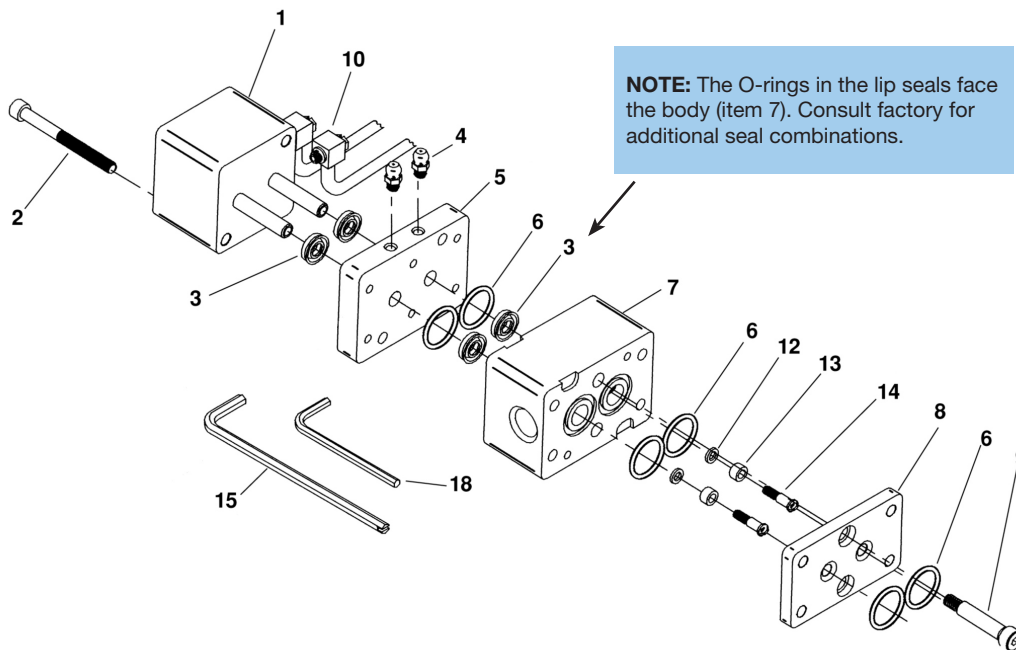

P/N	Ref. #	Qty.	Description
7702008	1	1	Single Air Cylinder with Hardened SS Shafts
7702295	2A	2	SHCS 10-24 x 2" long for Single Air Cylinder 450 Valve
7702325	2B	2	SHCS 10-24 x 3" long for Double Air Cylinder (not shown)
7702266	3A	4	Lip Seal: Viton® U-Cup and Viton O-ring
7702281	3B	4	Lip Seal: PU U-Cup and Viton O-ring
7702280	3C	4	Lip Seal: PTFE U-Cup and PTFE O-ring
7702277	3D	4	Lip Seal: UHMPE U-Cup and SS Spring
7702268	4	2	Grease Fitting, 10-32
7702270	5	1	Aluminum Tie Plate
7702813	6A	6	Viton O-ring
7702810	6B	6	EP O-ring
7702275	6C	6	PTFE Encapsulated O-ring
7702019	7A	1	Alum Body 9/16-18 Inlet Ports for 400 Valve
7702025	7B	1	SS Body 9/16-18 Inlet Ports for 400 Valve
7702026	8A	1	Stainless Steel Seat Plate for 400 Valve
7702028	9	2	Stainless Steel SHSS 1/4" Dia x 1" long for 400 Valve
7702297	10	2	Assembled Air Tube and Fitting 10-32 Thread
7702010	12A	2	Stainless Steel Washer for 400 Valve
7702011	13A	2	Front Seal for 400 Valve
7702012	14	2	Stainless Steel Adjustment Screw for 400 Valve
7702014	15	1	Adjustment Screw Driver for 400 Valve
7702364	16	1	Auto Grease Cartridge 3 oz (not shown)
7702373	17	1	Grease Gun
7702017	18	1	1/8" Short Arm Hex Key

Manifolds for Series 160 Disposable Mixers

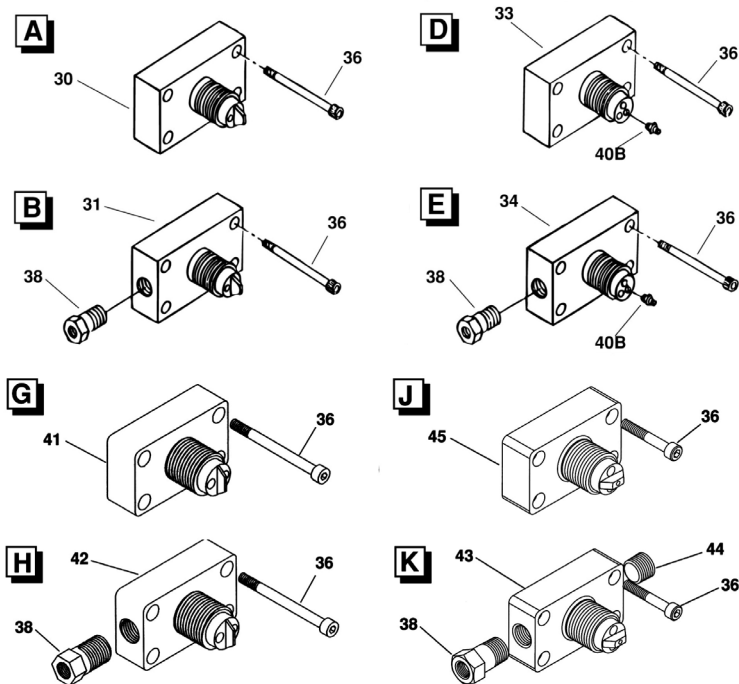

P/N	Ref. #	Qty.	Description
7702292	30A	1	Alum Manifold/160 Series 7/8-14 Thread, 1:1 Ratio
7702293	30B	1	SS Manifold/160 Series 7/8-14 Thread, 1:1 Ratio
7702322	31A	1	Alum Manifold/160 Series 7/8-14 Thread, 1:1 Ratio with 1/4 NPT Solvent Port
7702349	33A	1	Alum Manifold/160 Series 7/8-14 Thread, Wide Ratio
7702294	36	4	SHCS 10-24 x 2 1/2" long for 450 Manifold
7702492	38A	1	Check Valve: Brass Solvent Flush
7702494	38B	1	Check Valve: Stainless Steel Solvent Flush
7702327	40A	1	Polypropylene fitting, 10-32 with 0.09" orifice
7702328	40B	1	Polypropylene fitting, 10-32 with 0.06" orifice
7702329	40C	1	Polypropylene fitting, 10-32 with 0.04" orifice
7702033	41A	1	Alum Manifold/160 Series 7/8-14 Thread, 1:1 Ratio, High Flow
7702035	42A	1	Alum Manifold/160 Series 7/8-14 Thread, 1:1 Ratio, High Flow with 1/4 NPT Solvent Port
7702525	44A	1	1/4 NPT Plug
7702049	45A	1	Alum Manifold/160 Series 7/8-14 Thread, Wide Ratio, High Flow

Additional Manifolds available upon request:

- 1/2 MNPT*
- 30 ppm & 60 ppm flow rates for foam applications*

*These manifolds will not accept our 160 Series nozzles.

Mount

Hand Held with Pneumatic Switch #7701977

NOTE: Ref. Numbers 101, 103, and 110 can be purchased assembled #7702388

P/N	Ref. #	Qty.	Description
7702315	90	1	Handle / Aluminum / Cartridge Option
7702317	91	1	Trigger for Mount H or E
7702319	92	1	Trigger Bolt, 8-32 x 3/4" long
7702393	93	1	Trigger Guard for 400/450 Switches
7702396	94	1	6-32 x 5/16" FSHCS for 400/450 Switches
7702397	95	1	6-32 x 1/2" FSHCS for 400/450 Switches
7702390	96	1	Safety Lock for 400/450 Switches
7702391	97	1	1/2" OD x 1/16" O'Ring for 400/450 Switches
7702331	98	2	SHCS 10-24 x 1/2" long for Mount S, E or H
7702383	101	1	Protective Rubber Boot for 400/450 Switches
7702318	103	1	4 Way Cartridge Valve for Pneumatic Handle
7702342	104	1	Brass Plug 10-32
7702313	105	1	10-32 Barbed Air Fitting
7702398	106	1	3/4" Dia. Acetal Plug
7702297	107	4	10-32 UNF Elbow Air Fitting
7702306	108	1	1/8" ID Air Tubing x 2.25"
7702389	110	1	E-Clip

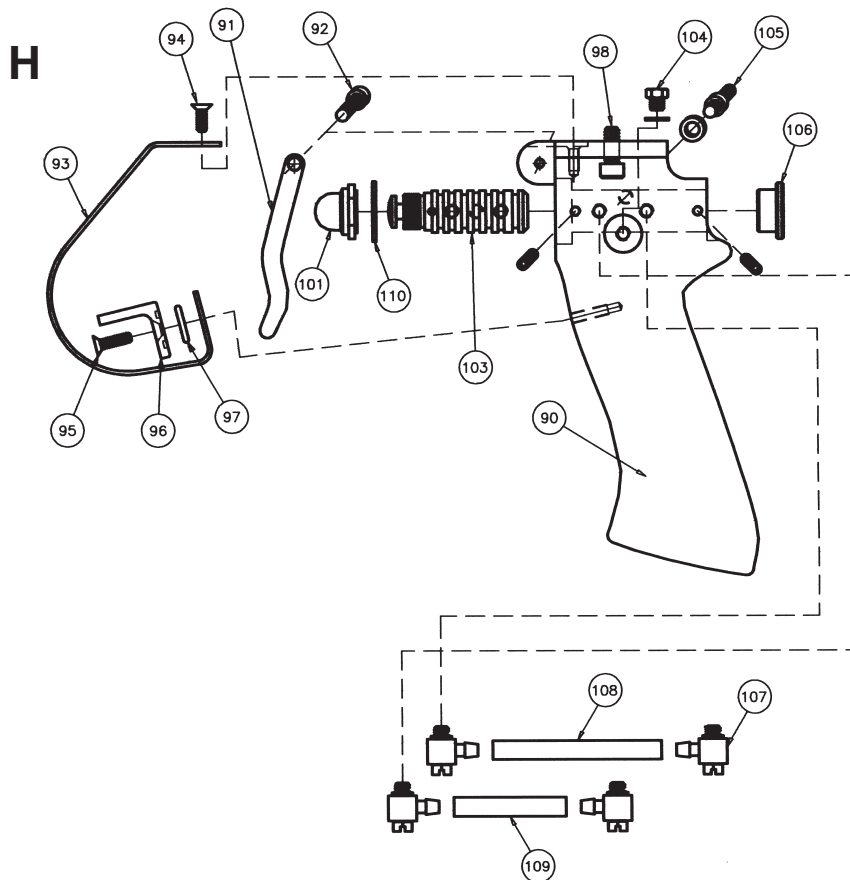

Mount (continued)

Hand Held – Electric Momentary Switch (24 Volt) #7701971

P/N	Ref. #	Qty.	Description
7702315	90	1	Handle / Aluminum / Cartridge Option
7702317	91	1	Trigger for Mount H or E
7702319	92	1	Trigger Bolt, 8-32 x 3/4" long
7702393	93	1	Trigger Guard for 400/450 Switches
7702396	94	1	6-32 x 5/16" FSHCS for 400/450 Switches
7702397	95	1	6-32 x 1/2" FSHCS for 400/450 Switches
7702390	96	1	Safety Lock for 400/450 Switches
7702391	97	1	1/2" OD x 1/16" O'Ring for 400/450 Switches
7702331	98	2	SHCS 10-24 x 1/2" long for Mount S, E or H
7702376	99	1	Momentary Switch Assembly for 400/450 Series
7702378	100	1	Complete Push on/off Switch Assembly for 400/450 Series
7702383	101	1	Protective Rubber Boot for 400/450 Switches
7702384	102	1	CS Flat Washer for 400/450 Switches

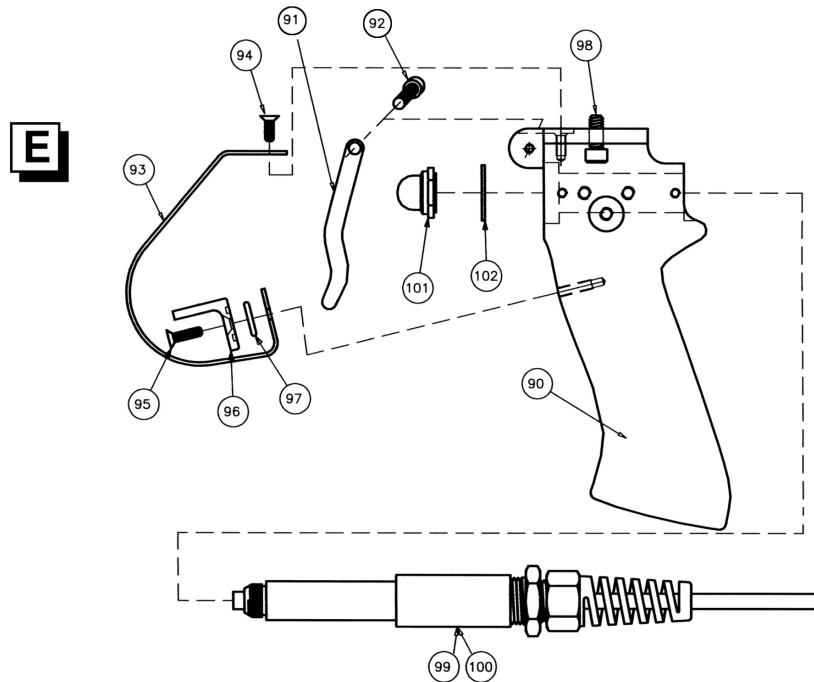

Air Cylinders – Single Hardened SS Shafts #7702315

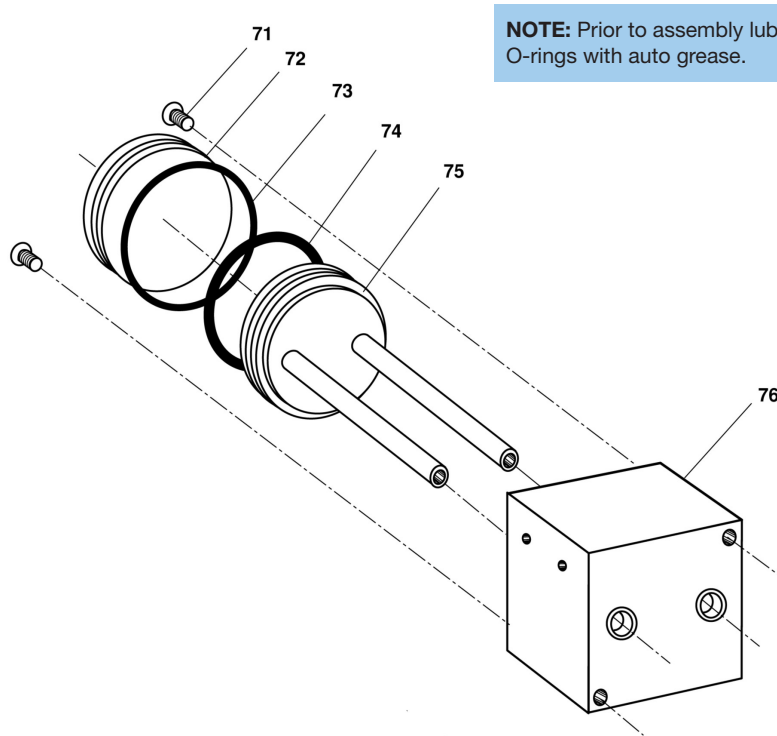

NOTE: Prior to assembly lubricate all O-rings with auto grease.

P/N	Ref. #	Qty.	Description
7702079	71	2	BHCS 1/4-20 x 1/2" long
7702402	72	1	Aluminum Back Plate
7702077	73	1	Brown Viton O-ring (Back Plate)
7702076	74	1	Brown Viton O-ring (Piston)
7702075	75	1	Replacement Piston and Hardened SS Shafts
7702074	76	1	Replacement Body with Front Seals

Air Cylinders – Double

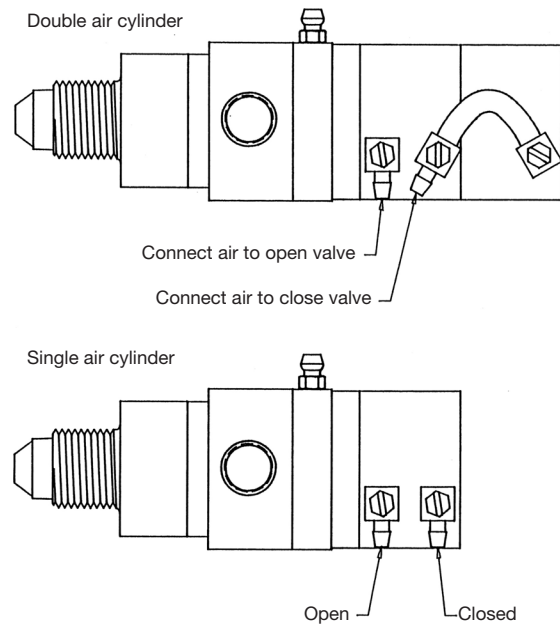

Spare Parts Kits

400 Autogun Repair Kits

Each kit contains a complete set of lip seals, O-rings, and front seals.

NOTE: 400 AutoGun requires only (4) lips seals. (2) Extra lip seals are provided as spares for future use.

Consult Factory for additional seal combinations.

AV-RK-TFV #7704092

Ref. No.	Qty.	Description
13	2	PTFE Front Seal
3	6	Viton U-Cup & Viton O-ring
6	6	Viton (brown) O-ring

AV-RK-TGT #7704093

Ref. No.	Qty.	Description
13	2	PTFE Front Seal
3	6	UHMPE U-Cup & SS Spring
6	6	PTFE encapsulated O-ring

AV-RK-TPV #7704095

Ref. No.	Qty.	Description
13	2	PTFE Front Seal
3	6	PU U-Cup & Viton O-ring
6	6	Viton (brown) O-ring

AV-RK-TTT #7704096

Ref. No.	Qty.	Description
13	2	PTFE Front Seal
3	6	PTFE U-Cup & PTFE O-ring
6	6	PTFE encapsulated O-ring

Accessories

Fluid Inlet Adapter for 400 Valve

Swivel Check Valve Adapters

For A & B materials, we offer a combination check valve/fluid inlet adapter. This rugged, all-in-one adapter provides a metal-to-metal seal for proven low maintenance in an ideal location. It also incorporates a swivel connection for ease of air purging.

P/N	Description
7702408	All SS, except Alum. collar, 1/4 FNPT

The valve body has 9/16-18 inlets. The following fittings are available to connect the A & B hoses.

NOTE: All fittings are supplied with EP O-rings. Optional Viton O-rings available on request. Substitute V for Viton instead of Part No. suffix E.

Carbon Steel Adapters

P/N	Description
7702420	90 degree Elbow with 3/8 FNPS
7702425	Straight Adapter with 3/8 FNPS

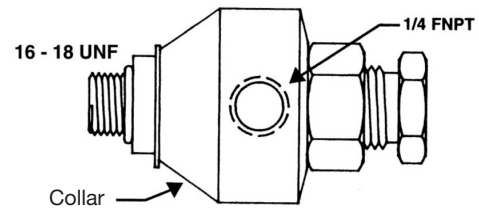

Accessories (continued)

Ratio Check Cap

In order to ensure correct A/B ratio, ratio checks should be performed regularly with our new Ratio Check Cap.

Night Cap

At night or on weekends, it is a good idea to seal your system. After the static mixer is removed, a night cap can be installed. This seals the system and makes startup simpler.

P/N	Description
7701184*	Ratio Check Cap with retaining nut
7701181*	Night Cap with retaining nut

*Use with 1:1 ratio manifolds only.

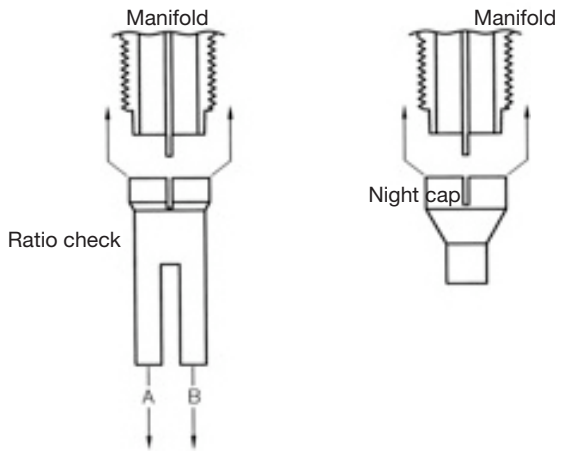

Troubleshooting

Problem	Possible Cause	Solution
No flow	Manifold clogged	Remove manifold and clean
	Air pressure too low	Requires 5.5 bar (80 psi) inlet pressure
	Air valve damaged	See Note 1 below
	Valve fouled	Disassemble (see Maintenance)
Valve leaks	Front seals (13) not seated	See Note 2 below
	Front seals (13) damaged	Replace seals
Valve drools	Air trapped in manifold	Review startup procedure
Off ratio A:B	Metering pumps	Check pumps
A & B back up into tie plate	Seals (3) damaged	Replace back lip seals (page 4)
Material not mixing	Mixer fouled	Replace mixer
	Off ratio A:B	Take ratio check
Mixer leaks	Manifold fouled	Clean nose of manifold
Lip seals deteriorated	Chemical attack	See Maintenance

NOTE 1: Inspect air cartridge valve (103) in handle (90). The On-Off function of the valve is controlled by this cartridge valve in the handle. The air cylinder requires air in the back to close and air in the front to open.

To inspect the cartridge valve, disconnect the two air lines on the air cylinder (1). When the trigger is depressed, air should be flowing only through the back air line and not through the front air line. When the trigger (91) is released the air should reverse.

NOTE 2: The front seals could flow into the seat plate (8). With valve closed, maintain air pressure on air cylinder to break in seals.



For Nordson EFD sales and service in over 40 countries, contact Nordson EFD or go to www.nordsonefd.com.

Global

800-556-3484; +1-401-431-7000
info@nordsonefd.com

Europe

00800 7001 7001
infoefd.europe@nordsonefd.com

Asia

China: +86 (21) 3866 9006; china@nordsonefd.com
India: +91 80 4021 3600; india@nordsonefd.com
Japan: +81 03 5762 2760; japan@nordsonefd.com
Korea: +82-31-736-8321; korea@nordsonefd.com
SEAsia: +65 6796 9522; sin-mal@nordsonefd.com

Viton is a registered trademark of E.I. DuPont.
The Wave Design is a trademark of Nordson Corporation.
©2023 Nordson Corporation 7703863 v072823