

Series 450 Autovalve / Snuff Back

Instructions / Parts Lists

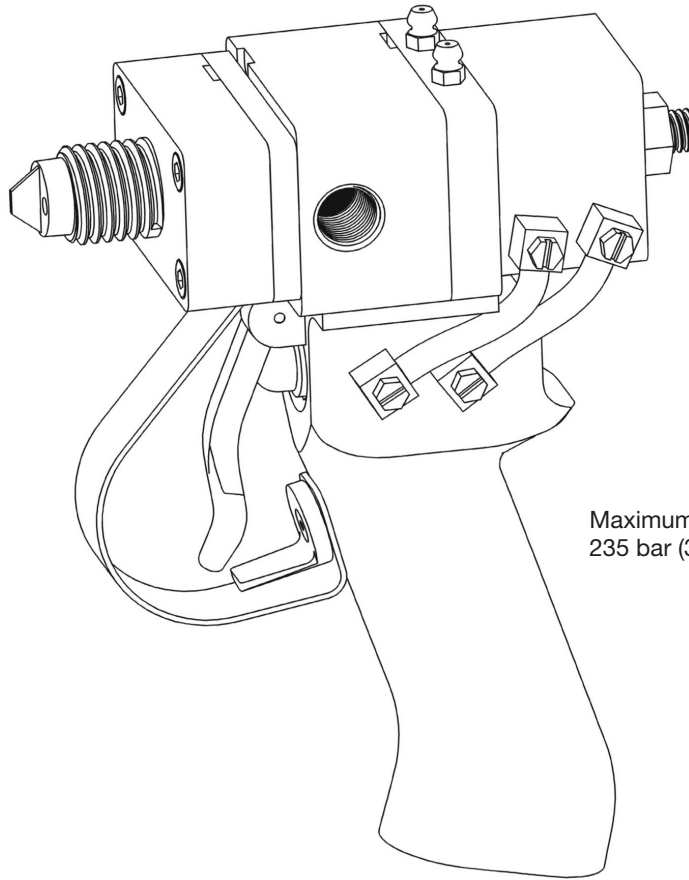

Maximum operating pressure
235 bar (3500 psi)

Contents

Contents	2
Operation.....	3
Installation	4
Connect Supply Lines.....	4
Startup	4
Maintenance.....	4
Routine Maintenance.....	4
Disassembly And Cleaning.....	6
Rebuilding the Autovalve.....	6
Final QC Check.....	6
Manifolds for Series 160 Disposable Mixers.....	8
Mount	9
Hand Held with Pneumatic Switch #7701977	9
#7701971 Hand Held — Electric Momentary Switch (24 Volt).....	10
Air Cylinder — #7702265 Hardened SS Shafts.....	11
450 Autovalve with Snuff-Back.....	12
Spare Parts Kits	12
Accessories	13
Hose Fittings for 450 Valves.....	13
Ratio Check Cap.....	14
Night Cap.....	14
Troubleshooting	15

Operation

The ON-OFF operation of the valve is controlled by movement of the piston inside the air cylinder (1).

In the OFF position, the piston retracts and the dual spool valves (75) seat into the front lip seals (3) which are located inside the seat plate (8).

In the ON position, the piston and the spool valves move forward (75) which allows A & B fluids to pass through the manifold.

To eliminate drooling or stringing of the adhesive out of the mix tube, the spool valves (75) can be retracted through the front lip seals (3). This snuff-back action is controlled by the adjustment screw (70) on the back of the air cylinder (1).

The snuff-back should be adjusted so the fluid just stops at the end of the mixing tube. Excessive snuff-back will cause premature plugging of the valve.

A disposable Series 160 mixer can be attached to the manifold. If the operating pressure exceeds 10 bar (150 psi), we recommend a metal jacket be used over the plastic mix tube. Refer to Catalog for details.

NOTE: For all reference numbers in parenthesis, see pages 7–11.

Your 450 AUTOVALVE in general...

- Designed to dispense two-component adhesives and sealants..
- Dispenses low or high viscosity urethanes, epoxies and silicones.
- Can be mounted for beads or timed shots; optional handle is available for hand held applications.
- Provides an ON-OFF function. The metering of the adhesives in the proper ratio of A:B is controlled by the metering pumps. A stationary mount or gantry installation requires a swivel mounting bracket. To complete purging, turn the valve with the mixer pointing up and dispense A & B.

Installation

Connect Supply Lines

The A & B fluid hoses are connected to the side of the valve body (7), between the valve and the pumps, and should be as short as possible. It is a good practice to install check valves in the hoses just before the valve. The optional fitting with check valve is listed on page 13.

For stationary mount, the air lines will be connected to the side of the air cylinder (1). Air to the front of the cylinder to close and air to the back to open. If the optional handle is used, air is connected to the barbed fitting (105) on the side of the handle.

The air line should have minimum pressure of 5.5 bar (80 psi).

Startup

With the hand-held model, start metering pumps and purge the air out of the A & B hoses and Autovalve. After the A and B fluids come out of the manifold, attach a mixer to the manifold and hold the valve upside down with the mixer pointing up. Dispensing A & B will purge the last pockets of air in the valve body.

A stationary mount or gantry installation requires a swivel mounting bracket. To complete purging, turn the valve with the mixer pointing up and dispense A & B.

1. Take a ratio check by weight of A:B after the manifold. The Autovalve does No Metering. The Volume Ratio of A:B is controlled by the metering pumps. However, between the metering pumps and the Autovalve are hoses. These hoses will expand under pressure and cause lead-lag problems. Lead-lag refers to the uneven starting of the A fluid before the B fluid. Nordson EFD offers 1:1 and wide ratio manifolds to reduce this problem. The selection of the correct manifold depends on both the volume and viscosity ratio of A and B. Consult EFD Technical Services for details at 800-556-3484.
2. Adjust snuff-back screw (70) for minimum snuff-back. See page 12 of this manual for valve details.

Maintenance

Two-component adhesives are messy and difficult to handle. It is important to note that routine maintenance must be observed. If one delays maintenance until the valve stops, cleanup is very time consuming.

Routine Maintenance

1. Release pressures in A and B fluid hoses. Remove manifold and clean. We recommend overnight soaking in a suitable solvent.
2. At the end of each shift, lubricate the back seals. We recommend auto grease. Pump auto grease through the grease fitting (4) and out the plug (11). Using extra grease will extend seal life.
3. To clean the spool valves (75), first release the pressure on the A and B fluid hose. Then remove the manifold, and advance the snuff-back adjustment (70) until the spool valves are protruding from the seat plate (8). With a toothbrush or rag soaked in solvent, brush the spool valves clean. Protective eyeglasses should be used.

NOTE: With moisture sensitive urethanes or epoxies the spool valves must be cleaned. After cleaning, coat them spool valves with auto grease.

4. The O-rings (6) and lip seals (3) are in a very harsh environment. In addition to resisting the adhesives, they must be inert to the strong solvents used in cleaning the valve.

Maintenance (continued)

The following options are available:

A. Chemical Compatibility with O-Rings

Usually the adhesives do not chemically attack the O-rings. However, during cleaning the valves are often immersed in aggressive solvents. The following types of O-rings are available:

Type of O-Ring	Color	Recommended for Contact With...
Viton®	Green or brown	<ul style="list-style-type: none"> • Methylene Chloride • Alcohol • Carbon Tetrachloride
EP	Black	<ul style="list-style-type: none"> • MEK • Ketones • Acetone
PTFE	Clear / orange	<ul style="list-style-type: none"> • All chemicals • Encapsulated

B. Selection of Lip Seals

The lip seal consists of a U-cup with an interior O-ring. The following types of lip seals are available:

- Polyurethane U-cup with an interior Viton O-Ring. Good general purpose seal with good chemical and wear resistance. U-cup colored orange with a brown Viton O-Ring. Recommended for filled abrasive adhesives.
- Viton U-cup with an interior Viton O-Ring. Good chemical resistance, but it is a soft seal with poor wear resistance. U-cup colored black with brown O-Ring.
- UHMPE U-cup and an interior SS Spring. Excellent chemical and wear resistance. U-cup colored white with SS Spring. Other combinations available upon request.

C. Chemical Compatability

The "A" or "B" resins can attack the seal material. An attacked seal will swell or become brittle in 3 to 14 days. If this occurs, choose an alternate seal material. Listed below are the general guidelines.

For specific recommendations for Meter Mix Dispensing, contact our Technical Service Department at 800-556-3484.

Part #7702281 (Polyurethane)

Color: Orange

Epoxies — General

Polyurethanes

Polysulfides

Part #7702277 (UHMPE)

Color: White

Epoxies — Amine Catalyst

Polyesters

Acrylics

Maintenance (continued)

Disassembly And Cleaning

1. Remove the manifold and seat plate (8). Pry bar slots are provided.
2. Remove the air cylinder bolts (2) and wiggle the air cylinder apart. If the assembly is frozen, use the pry bar slots on the valve body (7) to separate the valve body (7) from the tie plate (5). Insert flat pieces of metal between the valve body and the tie plate as per Figure 1. Thread the manifold screws (36) into the back of the tie plate and push the valve body apart. Apply uniform pressure to prevent the body from cocking and bending the spool valves (75).
3. Once apart, the parts should be cleaned. We recommend overnight soaking in suitable solvent. All parts can be soaked except the handle and air cylinder.

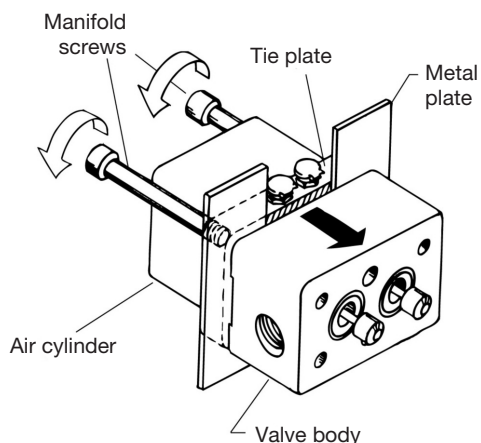

Figure 1

Rebuilding the Autovalve

1. After cleaning, inspect the following components:
 - a. Spool valves (75) for wear
 - b. Lip seals (3) — both outside and inside lip
 - c. Manually retract and extend spool valves from air cylinder (1).
 - d. If the optional handle is used, connect air into the inlet and check 4-way action of cartridge valve (103).
2. Lubricate lip seals (3) and shafts (75) with auto grease.
3. Insert four back lip seals (3): two into tie plate (5) and two into the valve body (7). The lip seals are two piece: an O-Ring and U-cup. They should always be installed with the O-Ring facing the material inlets (body of the valve).
4. Insert two front lip seals (3) that are located in the seat plate (8). They should be installed with the O-Ring facing the back of the valve (facing the air cylinder). Optional Installation: With O-Ring facing manifold. Used when minimum snuff-back is required. However, reduced seal life can be expected.
5. Insert O-Rings (6) and assemble air cylinder (1) and valve body (7). and the valve body (7) and engage the screws (2).
6. Push seat plate (8) through spool valves (75) and tighten bolts (9).

Final QC Check

Before the manifold is assembled, we recommend the following procedure:

1. Check the open and close movement of the spool valves (75).
2. Check gap between seat plate (8) and spool valve (75). Refer to Figure 2 when spool valves are in open position.
3. Check front lip seals by pressurizing the valve body (7) and applying soapy water into the front seals. The valve body can be pressurized by connecting air into the A and B inlet ports on the valve body.
4. Seat plate (8)

Maintenance (continued)

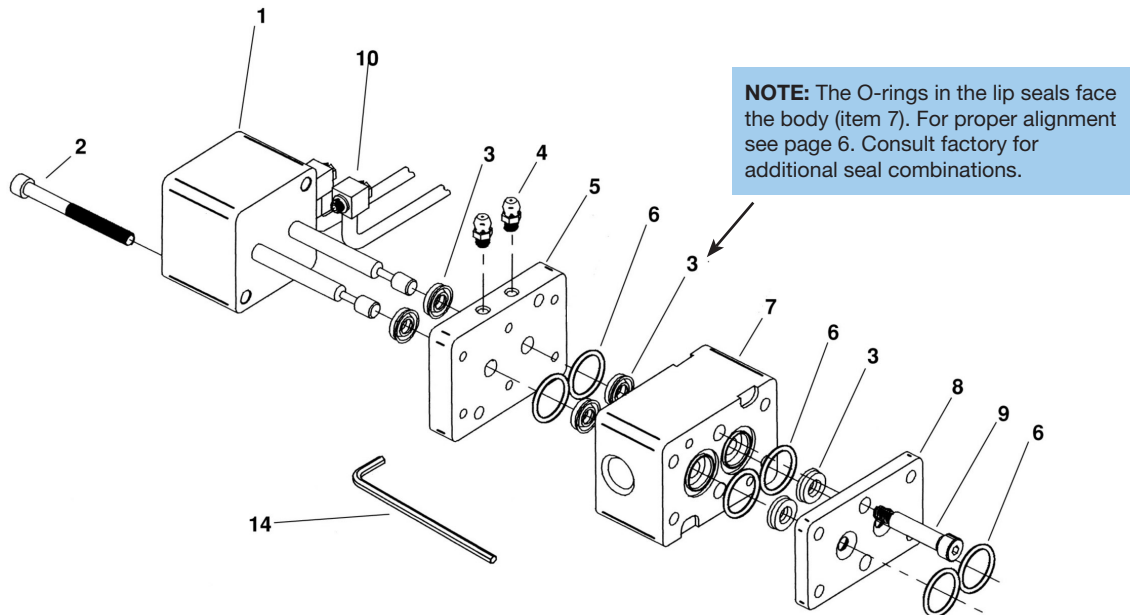

P/N	Ref. #	Qty.	Description
7702265	1	1	Single Air Cylinder 5/16" stroke with Hardened SS Shafts
7702295	2	2	SHCS 10-24 x 2" long for 450 Series
7702266	3A	6	Lip Seal: Viton U-cup and Viton O-Ring
7702281	3B	6	Lip Seal: PU U-cup and Viton O-Ring
7702280	3C	6	Lip Seal: PTFE U-cup and PTFE O-Ring
7702277	3D	6	Lip Seal: UHMPE U-cup and SS Spring
7702268	4	2	Grease Fitting, 10-32
7702270	5	1	Aluminum Tie Plate
7702813	6A	6	Viton O-Ring
7702810	6B	6	EP O-Ring
7702275	6C	6	PTFE Encapsulated O-Ring
7702284	7A	1	AlumBody 9/16-18 Inlet Ports for 450 Valve
7702287	7B	1	SS Body 9/16-18 Inlet Ports for 450 Valve
7702288	8	1	Stainless Steel Seat Plate for 450 Valve
7702289	9	2	Stainless Steel SHSS 1/4" Dia x 1 1/2" long for 450 Valve
7702297	10	2	Assembled Air Tube and Fitting 10-32 Thread
7702364	11	1	Auto Grease 3 oz Cartridge (not shown)
7702372	12	1	Grease Gun 3 oz Cartridge Complete (not shown)
7702015	13	1	Adjustment Screw Driver for 450 Valve

Manifolds for Series 160 Disposable Mixers

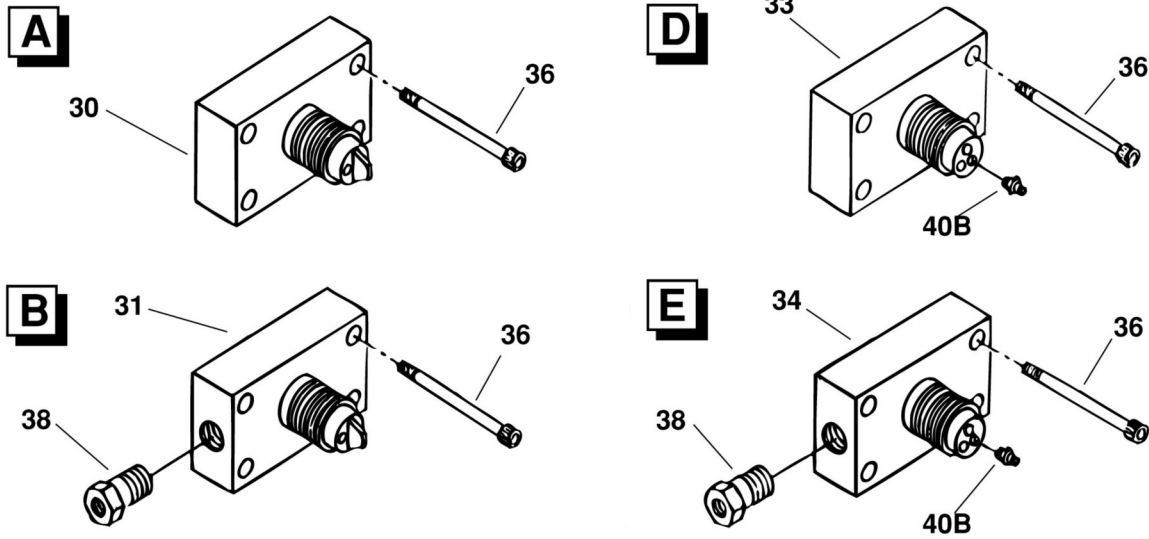

P/N	Ref. #	Qty.	Description
7702292	30A	1	Alum Manifold / 160 Ser. 7/8-14 Thread, 1:1 Ratio
7702293	30B	1	SS Manifold / 160 Ser. 7/8-14 Thread, 1:1 Ratio
7702322	31A	1	Alum Manifold / 160 Ser. 7/8-14 Thread, 1:1 Ratio with 1/4 NPT Solvent Port
7702349	33A	1	Alum Manifold / 160 Ser. 7/8-14 Thread, Wide Ratio
7702294	36	4	SHCS 10-24 x 2 1/2" long for 450 Manifold
7702492	38A	1	Check Valve: Brass Solvent Flush
7702494	38B	1	Check Valve: Stainless Steel Solvent Flush
7702327	40A	1	Polypropylene fitting, 10-32 with 0.09" orifice
7702328	40B	1	Polypropylene fitting, 10-32 with 0.06" orifice
7702329	40C	1	Polypropylene fitting, 10-32 with 0.04" orifice

Mount

Hand Held with Pneumatic Switch #7701977

NOTE: Ref. numbers 101, 103, and 110 can be purchased assembled as P/N 7702388.

P/N	Ref. #	Qty.	Description
7702315	90	1	Handle / Aluminum / Cartridge Option
7702317	91	1	Trigger for Mount H or E
7702319	92	1	Trigger Bolt, 8-32 x 3/4" long
7702393	93	1	Trigger Guard for 400 / 450 Switches
7702396	94	1	6-32 x 5/16" FSHCS for 400 / 450 Switches
7702397	95	1	6-32 x 1/2" FSHCS for 400 / 450 Switches
7702390	96	1	Safety Lock for 400 / 450 Switches
7702391	97	1	1/2" OD x 1/16" O'Ring for 400 / 450 Switches
7702331	98	2	SHCS 10-24 x 1/2" long for Mount S, E or H
7702383	101	1	Protective Rubber Boot for 400 / 450 Switches
7702318	103	1	4 Way Cartridge Valve for Pneumatic Handle
7702342	104	1	Brass Plug 10-32
7702313	105	1	10-32 Barbed Air Fitting
7702398	106	1	3/4" Dia. Acetal Plug
7702297	107	4	10-32 UNF Elbow Air Fitting
7702389	110	1	E-Clip
7702308	111	2	1/8" ID Air Tubing x 2.00"

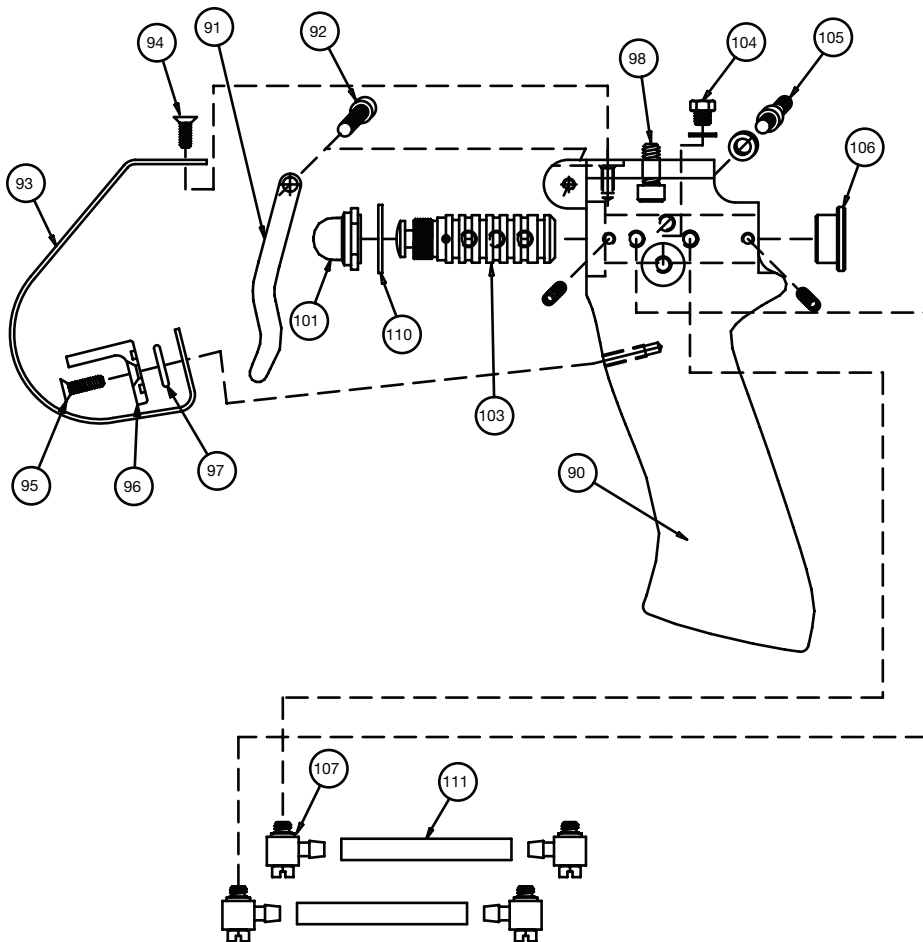

Mount (continued)

#7701971 Hand Held – Electric Momentary Switch (24 Volt)

P/N	Ref. #	Qty.	Description
7702315	90	1	Handle / Aluminum / Cartridge Option
7702317	91	1	Trigger for Mount H or E
7702319	92	1	Trigger Bolt, 8-32 x 3/4" long
7702393	93	1	Trigger Guard for 400 / 450 Switches
7702396	94	1	6-32 x 5/16" FSHCS for 400 / 450 Switches
7702397	95	1	6-32 x 1/2" FSHCS for 400 / 450 Switches
7702390	96	1	Safety Lock for 400 / 450 Switches
7702391	97	1	1/2" OD x 1/16" O'Ring for 400 / 450 Switches
7702331	98	2	SHCS 10-24 x 1/2" long for Mount S, E or H
7702376	99	1	Momentary Switch Assembly for 400 / 450 Series
7702378	100	1	Complete Push on / off Switch Assembly for 400 / 450 Series
7702383	101	1	Protective Rubber Boot for 400 / 450 Switches
7702384	102	1	CS Flat Washer for 400 / 450 Switches

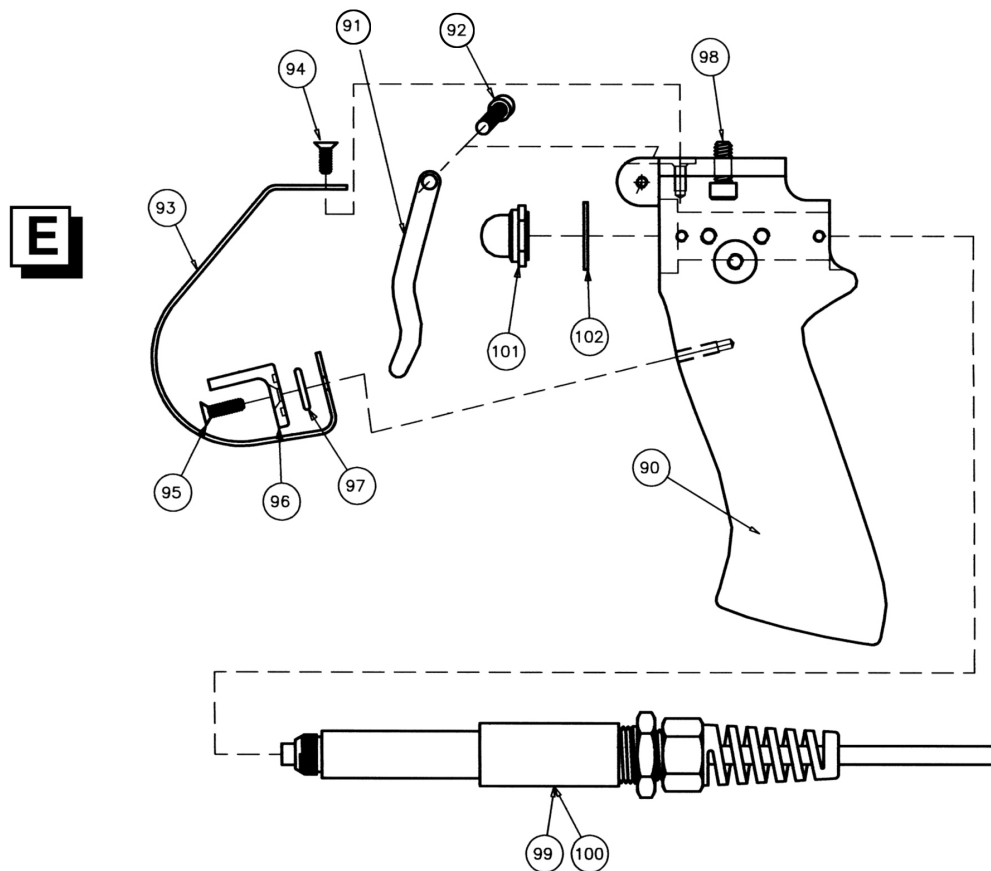

Air Cylinder — #7702265 Hardened SS Shafts

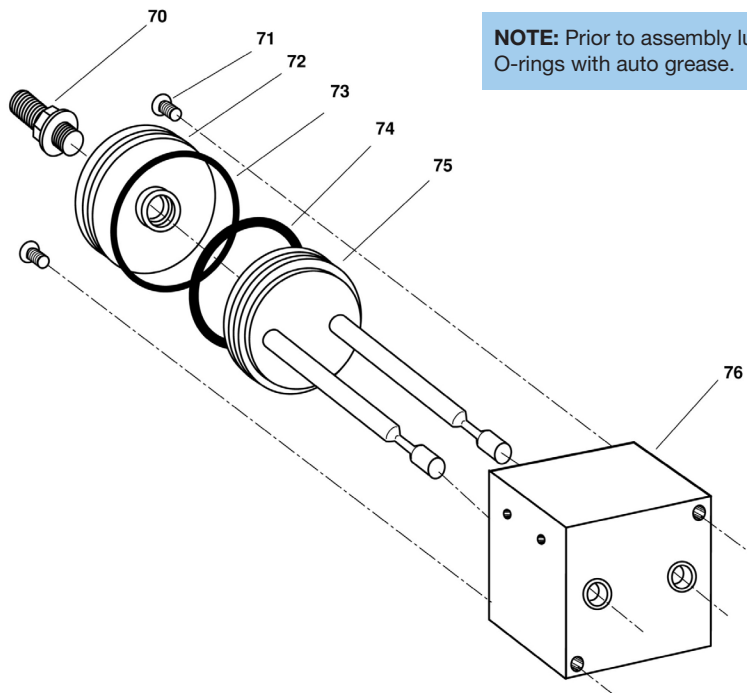

NOTE: Prior to assembly lubricate all O-rings with auto grease.

P/N	Ref. #	Qty.	Description
7702403	70	1	Snuff-Back Adjustment Screw
7702079	71	2	BHCS 1/4-20 x 1/2" long
7702402	72	1	Aluminum Back Plate
7702077	73	1	Brown Viton O-Ring (Back Plate)
7702076	74	1	Brown Viton O-Ring (Piston)
7702400	75	1	Replacement Piston and Hardened SS Shafts
7702074	76	1	Replacement Body with Front Seals

450 Autovalve with Snuff-Back

Snuff-Back Adjustment: Advancing (clockwise turn) the snuff-back adjustment screw reduces snuff-back, retracting it (counterclockwise) increases the snuff-back. Since excessive snuff-back action can cause plugging of the valve, adjust for minimum snuff-back as follows: With the pumps on and valve in the “closed” position, advance the adjustment screw until material begins to drool out of the static mixer (acting as if the valve is open). Then retract the screw just until fluid stops, at the minimum snuff-back position. If material drools or drips during operation, slightly increase the snuff-back until the desired action is achieved.

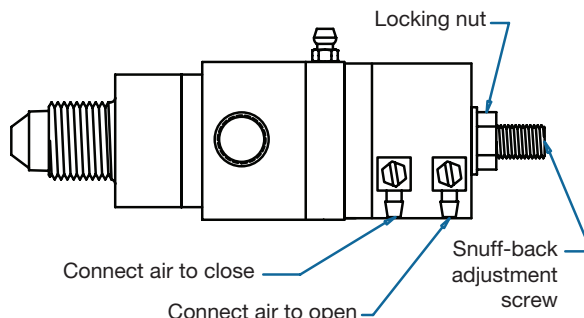

Spare Parts Kits

450 Autogun Repair Kits

Each kit contains a complete set of lip seals, O-rings, and front seals.

NOTE: Each 450 AutoGun comes with (2) front seals to be discarded.

Consult Factory for additional seal combinations.

AV-RK-TFV #7704092

Ref. No.	Qty.	Description
13	2	PTFE Front Seal
3	6	Viton U-cup & Viton O-ring
6	6	Viton (brown) O-ring

AV-RK-TPV #7704095

Ref. No.	Qty.	Description
13	2	PTFE Front Seal
3	6	PU U-cup & Viton O-ring
6	6	Viton (brown) O-ring

AV-RK-TGT #7704093

Ref. No.	Qty.	Description
13	2	PTFE Front Seal
3	6	UHMPE U-cup & SS Spring
6	6	PTFE encapsulated O-ring

AV-RK-TTT #7704096

Ref. No.	Qty.	Description
13	2	PTFE Front Seal
3	6	PTFE U-cup & PTFE O-ring
6	6	PTFE encapsulated O-ring

Accessories

Hose Fittings for 450 Valves

Swivel Check Valve Adapters

For A & B materials, we offer a combination check valve / fluid inlet adapter. This rugged, all in one, adapter provides a metal to metal seal for proven low maintenance, in an ideal location. It also incorporates a swivel connection for ease of air purging.

P/N	Description
7702408	All SS, except Alum. collar, 1/4 FNPT

The valve body has 9/16-18 inlets. The following fittings are available to connect the A & B hoses.

NOTE: All fittings are supplied with EP O-rings. Optional Viton O-rings available on request. Substitute V for Viton instead of Part No. suffix E.

Carbon Steel Adapters

P/N	Description
7702420	90 degree Elbow with 3/8 FNPS
7702425	Straight Adapter with 3/8 FNPS

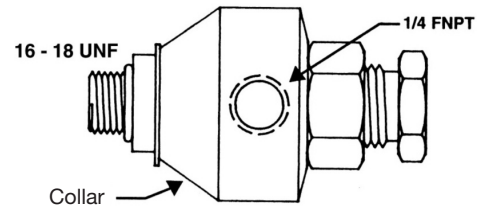

Accessories (continued)

Ratio Check Cap

In order to ensure correct A/B ratio, ratio checks should be performed regularly with our Ratio Check Cap.

Night Cap

At night or on weekends, it is a good idea to seal your system. After the static mixer is removed, a night cap can be installed. This seals the system and makes startup simpler.

P/N	Description
7701184*	Ratio Check Cap with retaining nut
7701181*	Night Cap with retaining nut

*Use with 1:1 ratio manifolds only.

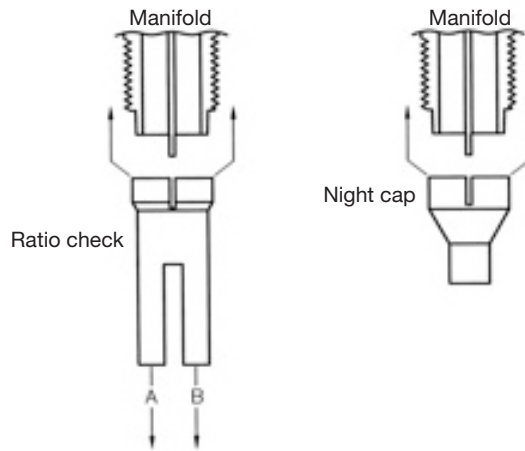

Troubleshooting

Problem	Possible Cause	Solution
No flow	Manifold clogged	Remove manifold and clean
	Air pressure too low	Requires 5.5 bar (80 psi) inlet pressure
	Air valve damaged	See Note 1 below
	Valve fouled	See Note 2 below Disassemble (see Maintenance)
Valve leaks	Snuff-back	Retract snuff-back screw (70)
	Spool valve (75) clogged	See Note 3 below
	Seals (3) worn	Replace seals (see Maintenance)
	Spool valve (75) worn	Inspect and replace if required
Valve drools	Air trapped in valve	Replace seals (see Maintenance)
	Seals (3) worn	Review Startup procedure
Off ratio A:B	Metering pumps	Check pumps
A & B back up into tie plate	Seals (3) damaged	Replace back lip seals (page 6)
Material not mixing	Mixer fouled	Replace mixer
	Off ratio A:B	Take ratio check
Mixer leaks	Manifold fouled	Clean nose of manifold
Lip seals deteriorated	Chemical attack	See Maintenance

NOTE 1: Inspect air cartridge valve (103) in handle (90). The On-Off function of the valve is controlled by this cartridge valve in the handle. The air cylinder requires air in the front to close and air in the back to open.

To inspect the cartridge valve, disconnect the two air lines on the air cylinder (1). When the trigger is depressed, air should be flowing only through the back air line and not through the front air line. When the trigger (91) is released the air should reverse.

NOTE 2: Advance the snuff-back screw (70) and pulse air into the air cylinder. Repeat 3 or 4 times.

NOTE 3: First release the pressure on the A and B hoses. Remove the manifold and advance the snuff-back screw (70) until the spool valves are protruding from the seat plate (8). With a toothbrush or rag soaked in solvent, brush the valves clean. After cleaning, depress trigger to retract spool valve.



For Nordson EFD sales and service in over 40 countries, contact Nordson EFD or go to www.nordsonefd.com.

Global

800-556-3484; +1-401-431-7000
info@nordsonefd.com

Europe

00800 7001 7001
infoefd.europe@nordsonefd.com

Asia

China: +86 (21) 3866 9006; china@nordsonefd.com
India: +91 80 4021 3600; india@nordsonefd.com
Japan: +81 03 5762 2760; japan@nordsonefd.com
Korea: +82-31-736-8321; korea@nordsonefd.com
SEAsia: +65 6796 9522; sin-mal@nordsonefd.com

Viton is a registered trademark of E.I. DuPont.
The Wave Design is a trademark of Nordson Corporation.
©2023 Nordson Corporation 7703864 v072823