

R&S®NRQ6

Frequency Selective Power Sensor

User Manual



1178369202
Version 10

ROHDE & SCHWARZ
Make ideas real



This manual describes the R&S®NRQ6 (1421.3509K02) with firmware version FW 02.40 and later.

© 2023 Rohde & Schwarz GmbH & Co. KG
Muehldorfstr. 15, 81671 Muenchen, Germany
Phone: +49 89 41 29 - 0
Email: info@rohde-schwarz.com
Internet: www.rohde-schwarz.com

Subject to change – data without tolerance limits is not binding.
R&S® is a registered trademark of Rohde & Schwarz GmbH & Co. KG.
All other trademarks are the properties of their respective owners.

1178.3692.02 | Version 10 | R&S®NRQ6

Throughout this manual, products from Rohde & Schwarz are indicated without the ® symbol , e.g. R&S®NRQ6 is indicated as R&S NRQ6.

Contents

1	Safety and regulatory information.....	9
1.1	Safety instructions.....	9
1.2	Labels on the product.....	10
1.3	Warning messages in the documentation.....	10
2	Welcome.....	11
2.1	Documentation overview.....	11
2.1.1	Getting started manual.....	11
2.1.2	User manual.....	11
2.1.3	CD-ROM.....	11
2.1.4	Application sheets.....	12
2.1.5	Tutorials.....	12
2.1.6	Instrument security procedures.....	12
2.1.7	Basic safety instructions.....	12
2.1.8	Data sheets and brochures.....	12
2.1.9	Release notes and open source acknowledgment (OSA).....	12
2.1.10	Application notes, application cards, white papers, etc.....	12
2.2	Key features.....	13
3	Preparing for use.....	14
3.1	Unpacking and checking.....	14
3.2	Choosing the operating site.....	14
3.3	Considerations for test setup.....	15
3.4	Connecting to a DUT.....	15
3.5	Connecting to a power supply.....	16
3.6	Connecting to a controlling host.....	17
3.6.1	Computer using a LAN connection.....	17
3.6.2	Computer using a USB connection.....	22
3.6.3	R&S NRX base unit.....	25
4	R&S NRQ6 tour.....	27
4.1	RF connector.....	27
4.2	Status information.....	28

4.3	LAN PoE+ interface.....	28
4.4	Host interface.....	30
4.5	Trigger 2 I/O (TRIG2).....	30
4.6	Reference I/O (REF).....	30
4.7	Clock I/O (CLK).....	31
4.8	Local oscillator I/O (LO).....	31
4.9	Fan openings.....	31
5	Operating concepts.....	32
5.1	R&S NRP Toolkit.....	32
5.1.1	Versions and downloads.....	32
5.1.2	System requirements.....	32
5.1.3	R&S NRP Toolkit for Windows.....	33
5.2	Browser-based user interface.....	34
5.2.1	Layout of the main dialog.....	35
5.2.2	Tooltips.....	37
5.2.3	Toolbar in charts.....	37
5.2.4	Setting parameters.....	38
5.3	R&S NRX.....	39
5.4	Remote control.....	40
6	Measurement basics.....	42
6.1	Functional principle.....	42
6.2	Measurement procedure in principle.....	42
6.3	Measurement duration.....	43
6.4	Improving measurement results.....	44
6.5	Impact of measurement parameters on noise.....	44
6.6	Potential sources of error.....	46
6.6.1	Spurious response frequencies.....	46
6.6.2	LO leakage.....	47
7	Adapting to the test signal.....	49
7.1	Automatic settings.....	49
7.2	Frequency configuration.....	50
7.2.1	Frequency tracker.....	50

7.2.2	Frequency adjustment for narrowband measurements.....	51
7.3	Resolution bandwidth filters.....	52
7.3.1	Filter characteristics.....	52
7.3.2	Automatic filter type selection.....	53
7.3.3	Choosing the correct filter type.....	54
7.4	RF input attenuation.....	56
7.5	Top pane parameters.....	57
8	Measurement modes and result displays.....	61
8.1	Continuous average mode.....	61
8.1.1	Averaging domains.....	61
8.1.2	Measuring modulated signals.....	63
8.1.3	Continuous average parameters.....	63
8.1.4	Continuous average result display.....	65
8.2	Trace mode.....	66
8.2.1	Trace parameters.....	66
8.2.2	Trace result display.....	68
8.3	ACLR mode.....	70
8.3.1	ACLR parameters.....	70
8.3.2	ACLR result display.....	71
8.3.3	DC zeroing in ACLR mode.....	72
8.4	IF spectrum preview.....	73
8.5	I/Q trace mode.....	73
8.5.1	Phase coherent measurements.....	74
8.5.2	Setting the sample rate.....	77
8.5.3	I/Q trace parameters.....	77
8.6	Power servoing.....	80
9	Measurement configuration.....	82
9.1	Controlling the measurement.....	82
9.1.1	Controlling the measurement results.....	82
9.1.2	Interplay of the controlling mechanisms.....	83
9.2	Trigger settings.....	88
9.2.1	Trigger states.....	88
9.2.2	Trigger sources.....	88

9.2.3	Dropout time.....	89
9.2.4	Hold-off time.....	90
9.2.5	Trigger jitter.....	90
9.2.6	Trigger sender usage.....	90
9.2.7	Trigger parameters.....	91
9.3	Correction settings.....	94
9.3.1	Corrections in the RF path.....	94
9.3.2	Corrections in the IF path.....	96
9.3.3	Correction parameters.....	99
9.4	Mixer settings.....	101
9.4.1	Local oscillator signal.....	102
9.4.2	Mixer parameters.....	102
9.5	Sensor settings.....	104
9.5.1	Clock source configuration.....	104
9.5.2	Sensor parameters.....	105
10	System configuration.....	107
10.1	Option management.....	107
10.1.1	Installing a license key.....	107
10.2	System parameters.....	108
11	Firmware update.....	112
11.1	Preparing the update.....	112
11.2	Updating the firmware.....	112
11.2.1	Using the web user interface.....	112
11.2.2	Using the Firmware Update for NRP Family program.....	113
11.2.3	Using remote control.....	116
12	Remote control commands.....	118
12.1	Conventions used in SCPI command descriptions.....	118
12.2	Common commands.....	119
12.3	Adapting to the test signal.....	123
12.4	Selecting a measurement mode.....	127
12.5	Starting and ending a measurement.....	128
12.6	Measurement results.....	129

12.6.1	Results of all kind.....	130
12.6.2	Retrieving continuous average results.....	132
12.6.3	Retrieving trace results.....	134
12.6.4	Retrieving ACLR results.....	135
12.6.5	Retrieving IF spectrum results.....	136
12.6.6	Retrieving I/Q trace results.....	136
12.6.7	Configuring results.....	136
12.7	Calibrating and zeroing.....	138
12.8	Running a selftest.....	143
12.9	Configuring measurement settings.....	144
12.9.1	Configuring a continuous average measurement.....	144
12.9.2	Configuring a trace measurement.....	147
12.9.3	Configuring an ACLR measurement.....	151
12.9.4	Configuring an IF spectrum.....	151
12.9.5	Configuring an I/Q trace mode.....	152
12.9.6	Configuring the trigger.....	153
12.9.7	Configuring the corrections.....	160
12.9.8	Configuring the mixer.....	172
12.9.9	Configuring the sensor.....	174
12.10	Configuring the system.....	176
12.11	Using the status register.....	189
12.11.1	General status register commands.....	189
12.11.2	Reading the CONDition part.....	190
12.11.3	Reading the EVENT part.....	190
12.11.4	Controlling the ENABLE part.....	190
12.11.5	Controlling the negative transition part.....	191
12.11.6	Controlling the positive transition part.....	191
13	Programming examples.....	192
14	Remote control basics.....	193
14.1	Remote control interfaces and protocols.....	193
14.1.1	USB interface.....	193
14.1.2	Ethernet interface.....	194
14.2	Status reporting system.....	196

14.2.1	Overview.....	196
14.2.2	Device status register.....	198
14.2.3	Questionable status register.....	199
14.2.4	Standard event status and enable register (ESR, ESE).....	201
14.2.5	Operation status register.....	202
15	Troubleshooting.....	207
15.1	Displaying status information.....	207
15.2	Error messages.....	207
15.2.1	Interpreting the error messages.....	208
15.3	Implausible measurement results.....	209
15.4	Performing a selftest.....	210
15.4.1	Interpreting the test results.....	211
15.5	Problems during a firmware update.....	213
15.6	Cannot establish a LAN connection.....	213
15.7	Contacting customer support.....	214
16	Transporting.....	215
17	Maintenance, storage and disposal.....	216
17.1	Regular checks.....	216
17.2	Cleaning.....	217
17.3	Storage.....	217
17.4	Disposal.....	217
	List of commands.....	219
	Index.....	225

1 Safety and regulatory information

The product documentation helps you use the product safely and efficiently. Follow the instructions provided here and in the following chapters.

Intended use

The R&S NRQ6 is intended for precise and fast power measurements in development and for monitoring and maintenance purposes. The supported base units are listed in the data sheet. Observe the operating conditions and performance limits stated in the data sheet.

Target audience

The target audience is developers and technicians. The required skills and experience in power measurements depend on the used operating concept.

Main applications are TX power calibration, band-limited power measurements on multistandard radios (MSR), fast power servoing and calibration of multiple active antenna modules for beamforming.

Where do I find safety information?

Safety information is part of the product documentation. It warns you of potential dangers and gives instructions on how to prevent personal injury or damage caused by dangerous situations. Safety information is provided as follows:

- In [Chapter 1.1, "Safety instructions"](#), on page 9. The same information is provided in many languages as printed "Safety Instructions". The printed "Safety Instructions" are delivered with the product.
- Throughout the documentation, safety instructions are provided when you need to take care during setup or operation.

1.1 Safety instructions

Products from the Rohde & Schwarz group of companies are manufactured according to the highest technical standards. To use the products safely, follow the instructions provided here and in the product documentation. Keep the product documentation nearby and offer it to other users.

Use the product only for its intended use and within its performance limits. Intended use and limits are described in the product documentation such as the data sheet, manuals and the printed "Safety Instructions". If you are unsure about the appropriate use, contact Rohde & Schwarz customer service.

Using the product requires specialists or specially trained personnel. These users also need sound knowledge of at least one of the languages in which the user interfaces and the product documentation are available.

Reconfigure or adjust the product only as described in the product documentation or the data sheet. Any other modifications can affect safety and are not permitted.

Never open the casing of the product. Only service personnel authorized by Rohde & Schwarz are allowed to repair the product. If any part of the product is damaged or broken, stop using the product. Contact Rohde & Schwarz customer service at <https://www.rohde-schwarz.com/support>.

Operating the product

Only use the product indoors. The product casing is not waterproof.

Observe the ambient conditions such as altitude, operating temperature and climatic loads; see the data sheet.

Meaning of safety labels

Safety labels on the product warn against potential hazards.

	<p>Potential hazard Read the product documentation to avoid personal injury or product damage.</p>
-----------------------------------------------------------------------------------	--------------------------------------------------------------------------------------------------------

1.2 Labels on the product

Labels on the product inform about:

- Personal safety
See "[Meaning of safety labels](#)" on page 10.
- Environment safety
See [Table 1-1](#).
- Identification of the product
See "[Default hostname](#)" on page 21.

Table 1-1: Labels regarding environment safety

	<p>Labeling in line with EN 50419 for disposal of electrical and electronic equipment after the product has come to the end of its service life. For more information, see "Disposing electrical and electronic equipment" on page 217.</p>
-------------------------------------------------------------------------------------	-----------------------------------------------------------------------------------------------------------------------------------------------------------------------------------------------------------------------------------------------------------------

1.3 Warning messages in the documentation

A warning message points out a risk or danger that you need to be aware of. The signal word indicates the severity of the safety hazard and how likely it will occur if you do not follow the safety precautions.

NOTICE

Potential risks of damage. Could result in damage to the supported product or to other property.

2 Welcome

This chapter provides an overview of the user documentation and an introduction to the R&S NRQ6.

2.1 Documentation overview

This section provides an overview of the R&S NRQ6 user documentation. Unless specified otherwise, you find the documents at:

www.rohde-schwarz.com/manual/NRQ6

Further documents are available at:

www.rohde-schwarz.com/product/NRQ6

2.1.1 Getting started manual

Introduces the R&S NRQ6 and describes how to set up and start working with the product. A printed version is delivered with the R&S NRQ6.

2.1.2 User manual

Contains the description of all instrument modes and functions. It also provides an introduction to remote control, a complete description of the remote control commands with programming examples, and information on maintenance, instrument interfaces and error messages. Includes the contents of the getting started manual.

The user manual is also available for download or for immediate display on the Internet.

2.1.3 CD-ROM

Provides quick access to valuable information about the usage of the R&S NRQ6. Delivered with the R&S NRQ6. Most of the information is also provided at the R&S Internet site, but on different pages.

- Useful software for installation, operation and remote control
- Product documentation (including open source acknowledgment document)
- Certificates
- Links to useful sites on the Rohde & Schwarz website

2.1.4 Application sheets

Deal with special tasks and their practical solution.

2.1.5 Tutorials

Tutorials offer guided examples and demonstrations on operating the R&S NRQ6. They are provided on the product page of the internet.

2.1.6 Instrument security procedures

Deals with security issues when working with the R&S NRQ6 in secure areas. It is available for download on the Internet.

2.1.7 Basic safety instructions

Contains safety instructions, operating conditions and further important information. The printed document is delivered with the R&S NRQ6.

2.1.8 Data sheets and brochures

The data sheet contains the technical specifications of the R&S NRQ6. It also lists the options and their order numbers, and optional accessories.

The brochure provides an overview of the instrument and deals with the specific characteristics.

See www.rohde-schwarz.com/brochure-datasheet/NRQ6

2.1.9 Release notes and open source acknowledgment (OSA)

The release notes list new features, improvements and known issues of the current firmware version, and describe the firmware installation.

The "Open Source Acknowledgment" is provided on the user documentation CD-ROM, included in the delivery. It contains verbatim license texts of the used open source software.

See www.rohde-schwarz.com/firmware/NRQ6

2.1.10 Application notes, application cards, white papers, etc.

These documents deal with special applications or background information on particular topics.

See www.rohde-schwarz.com/application/NRQ6

2.2 Key features

The R&S NRQ6 frequency selective power sensor sets standards in RF performance and usability. Outstanding key features are:

- Combines the advantages of a measurement receiver (dynamic range, linearity & video bandwidth) and a conventional diode-based or thermal power sensor (stability, absolute accuracy & source match).
- Easy operation with features such as browser-based user interface, autoset configuration, automatic frequency tracking or spectral preview (signal check).
- Measurements in low RF level ranges that are beyond the range of classical power meters. Faster measurements in the RF level range close to the lower boundary of classical power meters.
- Frequency selective measurements with adjustable bandwidth including a built-in ACLR measurement function

For a detailed specification, refer to the data sheet.

3 Preparing for use

Here, you can find basic information about setting up the product for the first time.

• Unpacking and checking	14
• Choosing the operating site	14
• Considerations for test setup	15
• Connecting to a DUT	15
• Connecting to a power supply	16
• Connecting to a controlling host	17

3.1 Unpacking and checking

1. Unpack the product carefully.
2. Retain the original packing material. Use it when transporting or shipping the product later.
3. Using the delivery notes, check the equipment for completeness.
4. Check the equipment for damage.

If the delivery is incomplete or equipment is damaged, contact Rohde & Schwarz.

3.2 Choosing the operating site

Specific operating conditions ensure proper operation and avoid damage to the product and connected devices. For information on environmental conditions such as ambient temperature and humidity, see the data sheet.

Electromagnetic compatibility classes

The electromagnetic compatibility (EMC) class indicates where you can operate the product. The EMC class of the product is given in the data sheet.

- Class B equipment is suitable for use in:
 - Residential environments
 - Environments that are directly connected to a low-voltage supply network that supplies residential buildings
- Class A equipment is intended for use in industrial environments. It can cause radio disturbances in residential environments due to possible conducted and radiated disturbances. It is therefore not suitable for class B environments. If class A equipment causes radio disturbances, take appropriate measures to eliminate them.

3.3 Considerations for test setup

Electromagnetic interference (EMI) can affect the measurement results.

To suppress electromagnetic radiation during operation:

- Use high-quality shielded cables, for example, double-shielded RF and interface cables.
- Always terminate open cable ends.
- Ensure that connected external devices comply with EMC regulations.

Signal input and output levels

Information on signal levels is provided in the data sheet. Keep the signal levels within the specified ranges to avoid damage to the product and connected devices.

Allow sufficient airflow

The R&S NRQ6 has fan openings at both sides of the casing, as shown in [Figure 4-1](#). If the R&S NRQ6 runs with insufficient airflow for a longer period, the R&S NRQ6 overheats. Overheating can disturb the operation, damage the R&S NRQ6 and lead to wrong measurement results.

When setting up the measurement assembly, be careful to allow sufficient airflow. Make sure of the following:

- All fan openings are unobstructed.
- Airflow perforations are unimpeded.
- Minimum distance between the fan openings and any object is 10 cm.

3.4 Connecting to a DUT

For connecting the R&S NRQ6 to a DUT, use the RF connector of the R&S NRQ6. See [Chapter 4.1, "RF connector"](#), on page 27.

To connect to the DUT

1. Ensure that the RF connector of your DUT is compatible with the RF connector of the R&S NRQ6.
2. Inspect both RF connectors carefully. Look for metal particles, contaminants and defects.

If one of the RF connectors is damaged, do not proceed, because the risk of damaging the mating connector is too high.

See also [Chapter 17.1, "Regular checks"](#), on page 216.

3. Insert the RF connector straight into the RF output of your DUT. Take care not to tilt it.

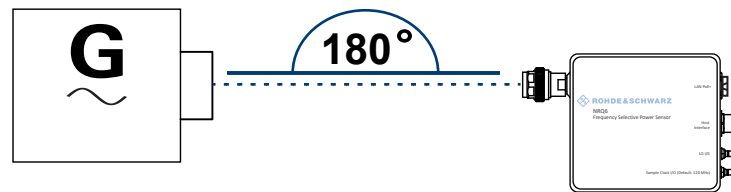

4. **NOTICE!** Risk of damaging the center pin of the RF connector. Only rotate the hex nut of the RF connector. Never rotate the R&S NRQ6 itself.
Tighten the RF connector manually.
5. Tighten the RF connector using a torque wrench with the nominal torque of 1.36 Nm (12" lbs) to ensure maximum measurement accuracy.

To disconnect from the DUT

1. **NOTICE!** Risk of damaging the center pin of the RF connector. Only rotate the hex nut of the RF connector. Never rotate the R&S NRQ6 itself.
Carefully loosen the union nut at the front of the RF connector of the R&S NRQ6.
2. Remove the R&S NRQ6.

3.5 Connecting to a power supply

The power for the R&S NRQ6 is supplied over the LAN PoE+ interface. See also [Chapter 4.3, "LAN PoE+ interface"](#), on page 28.

Choose the PoE+ power-sourcing equipment (PSE) with care

Only use PoE+ power-sourcing equipment (PSE) as specified in the IEEE 802.3at standard. Otherwise, the following can happen:

- If too much power is supplied, the R&S NRQ6 can get overheated and become damaged as a result.
- If the supplied power is not sufficient, the R&S NRQ6 does not work properly or not at all.

To connect to a LAN PoE+ interface

1. Use a suitable cable as described in [Chapter 4.3, "LAN PoE+ interface"](#), on page 28.
2. Connect one end of the cable to the LAN interface of the R&S NRQ6.
3. Connect the other end of the cable to one of the following:
 - PoE+ port of a LAN switch:
See [Chapter 3.6.1.1, "Setup with a PoE+ ethernet switch"](#), on page 18.
 - Output of a PoE+ injector:
See [Chapter 3.6.1.2, "Setup with a PoE+ injector and a non-PoE+ ethernet switch"](#), on page 19.

See [Chapter 3.6.1.3, "Setup with a PoE+ injector"](#), on page 20.

3.6 Connecting to a controlling host

For operating the R&S NRQ6, you can choose from various possibilities. For details, see [Chapter 5, "Operating concepts"](#), on page 32.

The suitable interface depends on the controlling host:

- Computer
 - LAN interface
 - USB interface
- R&S NRX
 - Host interface

Contents:

- [Computer using a LAN connection](#)..... 17
- [Computer using a USB connection](#)..... 22
- [R&S NRX base unit](#)..... 25

3.6.1 Computer using a LAN connection

There are different ways to connect the R&S NRQ6 to a computer according to the available equipment. The power for the R&S NRQ6 is supplied over the LAN PoE+ interface.

Further information:

- [Chapter 3.5, "Connecting to a power supply"](#), on page 16
- [Chapter 14.1, "Remote control interfaces and protocols"](#), on page 193

Contents:

- [Setup with a PoE+ ethernet switch](#)..... 18
- [Setup with a PoE+ injector and a non-PoE+ ethernet switch](#)..... 19
- [Setup with a PoE+ injector](#)..... 20
- [Establishing a connection](#)..... 20
- [Using hostnames](#)..... 21
- [Assigning the IP address](#)..... 22

3.6.1.1 Setup with a PoE+ ethernet switch

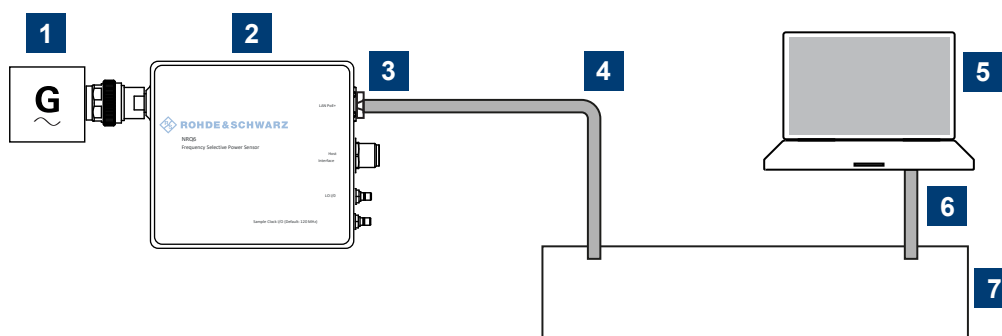

Figure 3-1: Setup with a PoE+ Ethernet switch

- 1 = Signal source (DUT)
- 2 = R&S NRQ6
- 3 = RJ.45 Ethernet connector
- 4, 6 = RJ.45 Ethernet cable
- 5 = Computer
- 7 = Ethernet switch supporting PoE+ power delivery

1. Connect the RF connector of the R&S NRQ6 to the DUT. See [Chapter 3.4, "Connecting to a DUT"](#), on page 15.
2. Connect the RJ.45 Ethernet connector of the R&S NRQ6 to an Ethernet switch that supports PoE+ power delivery.
3. Connect the computer to the Ethernet switch.
4. Establish a connection between the R&S NRQ6 and the network. See [Chapter 3.6.1.4, "Establishing a connection"](#), on page 20.

3.6.1.2 Setup with a PoE+ injector and a non-PoE+ ethernet switch

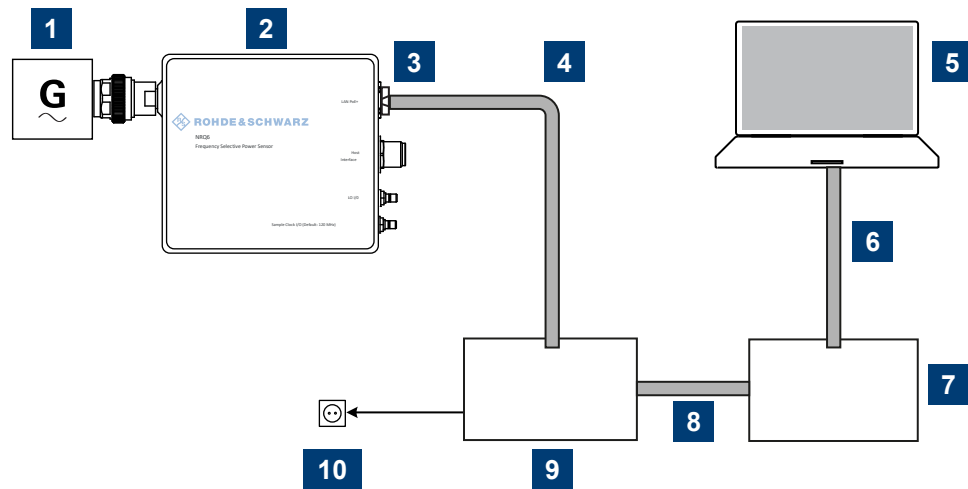

Figure 3-2: Setup with a PoE+ injector and a Non-PoE+ Ethernet switch

- 1 = Signal source (DUT)
- 2 = R&S NRQ6
- 3 = RJ.45 Ethernet connector
- 4, 6, 8 = RJ.45 Ethernet cable
- 5 = Computer
- 7 = Non-PoE+ Ethernet switch
- 9 = PoE+ injector
- 10 = AC supply

1. Connect the RF connector of the R&S NRQ6 to the DUT. See [Chapter 3.4, "Connecting to a DUT"](#), on page 15.
2. Connect the RJ.45 Ethernet connector of the R&S NRQ6 to the output of the PoE+ injector.
3. Connect the PoE+ injector to a power supply.
4. Connect the input of the PoE+ injector to the non-PoE+ Ethernet switch.
5. Connect the computer to the non-PoE+ Ethernet switch.
6. Establish a connection between the R&S NRQ6 and the network. See [Chapter 3.6.1.4, "Establishing a connection"](#), on page 20.

3.6.1.3 Setup with a PoE+ injector

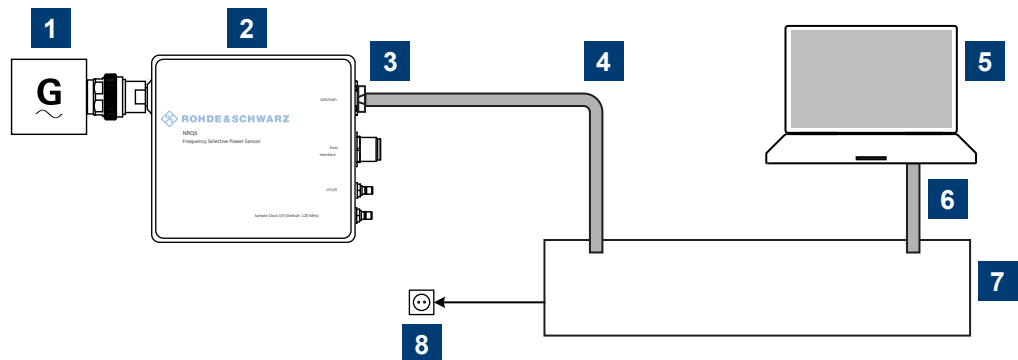

Figure 3-3: Setup with a PoE+ injector

- 1 = Signal source (DUT)
- 2 = R&S NRQ6
- 3 = RJ.45 Ethernet connector
- 4, 6 = RJ.45 Ethernet cable
- 5 = Computer
- 7 = PoE+ injector
- 8 = AC supply

1. Connect the RF connector of the R&S NRQ6 to the DUT. See [Chapter 3.4, "Connecting to a DUT"](#), on page 15.
2. Connect the RJ.45 Ethernet connector of the R&S NRQ6 to the output of the PoE+ injector.
3. Connect the PoE+ injector to a power supply.
4. Connect the computer to the input of the PoE+ injector.
5. Establish a connection between the R&S NRQ6 and the network. See [Chapter 3.6.1.4, "Establishing a connection"](#), on page 20.

3.6.1.4 Establishing a connection

There are two methods to establish a network connection:

- R&S NRQ6 and computer are connected to a common network. (infrastructure network).
- R&S NRQ6 and computer are connected only over the switch. (peer-to-peer network).

In both cases, you can address the R&S NRQ6 as follows:

- [Chapter 3.6.1.5, "Using hostnames"](#), on page 21
- [Chapter 3.6.1.6, "Assigning the IP address"](#), on page 22

To set up a network Ethernet connection

1. Connect the R&S NRQ6 to the network or to a single computer.

By default, the R&S NRQ6 is configured to use dynamic TCP/IP configuration (DHCP) and to obtain the address information automatically.

If both LAN status LEDs are illuminated in green color, the R&S NRQ6 is correctly connected to the network.

Note: Establishing a connection can take up to 2 minutes per device.

2. If the LAN status LEDs show another state, no connection is possible. For possible solutions, see:
 - [Chapter 4.3, "LAN PoE+ interface"](#), on page 28
 - [Chapter 15.6, "Cannot establish a LAN connection"](#), on page 213

3.6.1.5 Using hostnames

In a LAN that uses a domain name system (DNS) server, you can address each computer or instrument connected in the LAN using its unique hostname instead of the IP address. The DNS server translates the hostname into the IP address. The hostname is especially useful when using a DHCP server, as a new IP address can be assigned each time the instrument is restarted.

The R&S NRQ6 is delivered with a default hostname that you can change.

Default hostname

The default hostname follows the syntax:

`<device name>-<serial number>`, where:

- `<device name>` is the short name of your R&S NRQ6. For example, the `<device name>` of an R&S NRQ6 is `nrq6`.
- `<serial number>` is the individual serial number of the R&S NRQ6. The serial number is printed on the bar code sticker at the rear side of the R&S NRQ6. It is the third part of the device ID:

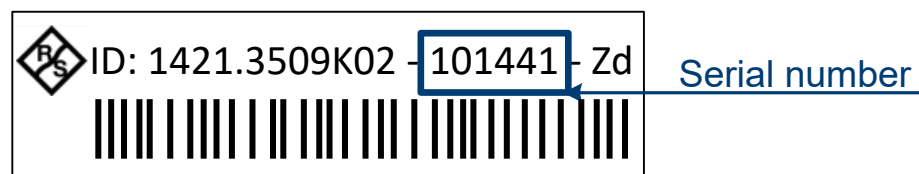

Example:

Serial number of the R&S NRQ6: *101441*

Default hostname: `nrq6-101441`

Hostname in zero configuration networks, including peer-to-peer networks

The R&S NRQ6 supports zero configuration networking, used in networks without DHCP server, such as peer-to-peer networks. Thus, you can connect the R&S NRQ6 to a network without setting up services such as dynamic host configuration protocol (DHCP) and domain name system (DNS), or configuring the network settings manually.

For establishing a connection to the R&S NRQ6, try the default hostname and the hostname extended with `.local` as shown in the example below. All communication for resolving names in the top-level-domain (TLD) `.local` are defined to be executed using dedicated local services and ports if no other DNS (domain name server) is available.

Example:

Default hostname: `nrq6-101441`

Extended hostname: `nrq6-101441.local`

3.6.1.6 Assigning the IP address

Depending on the network capabilities, the TCP/IP address information for the R&S NRQ6 is obtained in different ways:

- If the network supports dynamic TCP/IP configuration using the dynamic host configuration protocol (DHCP), the address information is assigned automatically.
- If the network does not support DHCP, the R&S NRQ6 tries to obtain the IP address via the Zeroconf (APIPA = automatic private IP addressing) protocol. If this attempt does not succeed or if the R&S NRQ6 is set to use an alternate TCP/IP configuration, you have to set the IP address manually.
For a description on how to set the IP address manually, see ["IP Address"](#) on page 108.



Identify the R&S NRQ6 using hostnames

In networks using a DHCP server, it is recommended that you address the R&S NRQ6 by its unique hostname, see [Chapter 3.6.1.5, "Using hostnames"](#), on page 21.

A hostname is a unique identifier of the R&S NRQ6 that remains permanent as long as it is not explicitly changed. Hence, you can address an R&S NRQ6 by the same identification, irrespective of whether it is a network or a point-to-point connection.

3.6.2 Computer using a USB connection

You can connect an R&S NRQ6 to a computer using the host interface and control it as described in [Chapter 5, "Operating concepts"](#), on page 32.

Further information:

- [Chapter 14.1, "Remote control interfaces and protocols"](#), on page 193

Contents:

- [Simple USB connection](#)..... 23
- [R&S NRP-Z5 sensor hub setup](#)..... 24

3.6.2.1 Simple USB connection

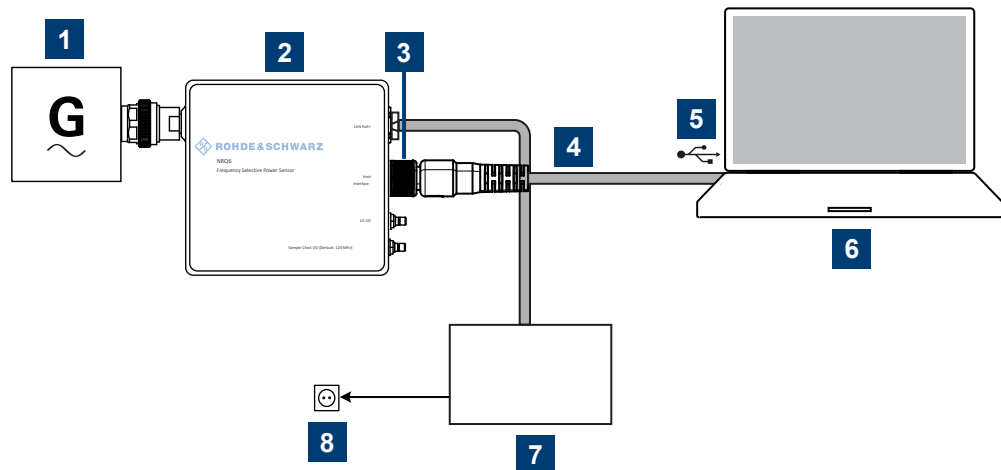

Figure 3-4: Setup with an R&S NRP-ZKU cable

- 1 = Signal source (DUT)
- 2 = R&S NRQ6
- 3 = Host interface connector
- 4 = R&S NRP-ZKU cable
- 5 = USB connector
- 6 = Computer with installed VISA driver or R&S NRP Toolkit
- 7 = PoE+ injector
- 8 = AC supply

1. Connect the R&S NRQ6 to the signal source (DUT). See [Chapter 3.4, "Connecting to a DUT"](#), on page 15.
2. Connect the R&S NRQ6 to the power supply. See [Chapter 3.5, "Connecting to a power supply"](#), on page 16.
3. Connect the R&S NRP-ZKU cable to the host interface connector of the R&S NRQ6:
 - a) Insert the screw-lock cable connector of the R&S NRP-ZKU cable into the host interface connector. Take care that the guide lug on the left side of the host interface connector fits into the guide gap of the cable connector.



1 = Guide lug

- b) To minimize the chance of cross-threading, turn the end cap counterclockwise until the threads of the end cap align with the threads of the connector.
 - c) Tighten the union nut carefully without using any force.
4. Connect the USB connector of the R&S NRP-ZKU cable to the USB host.



If the computer has a USB-C port, use an R&S NRP-ZKC cable instead of an R&S NRP-ZKU cable.

- ▶ If you want to disconnect the cable from the host interface:
 - a) Loosen the union nut of the screw-lock cable connector.
 - b) Remove the cable.

3.6.2.2 R&S NRP-Z5 sensor hub setup

The R&S NRP-Z5 sensor hub (high-speed USB 2.0) can host up to four R&S NRQ6 power sensors and provides simultaneous external triggering to all connected sensors. It comes with an external power supply unit, a power cable and a USB cable.

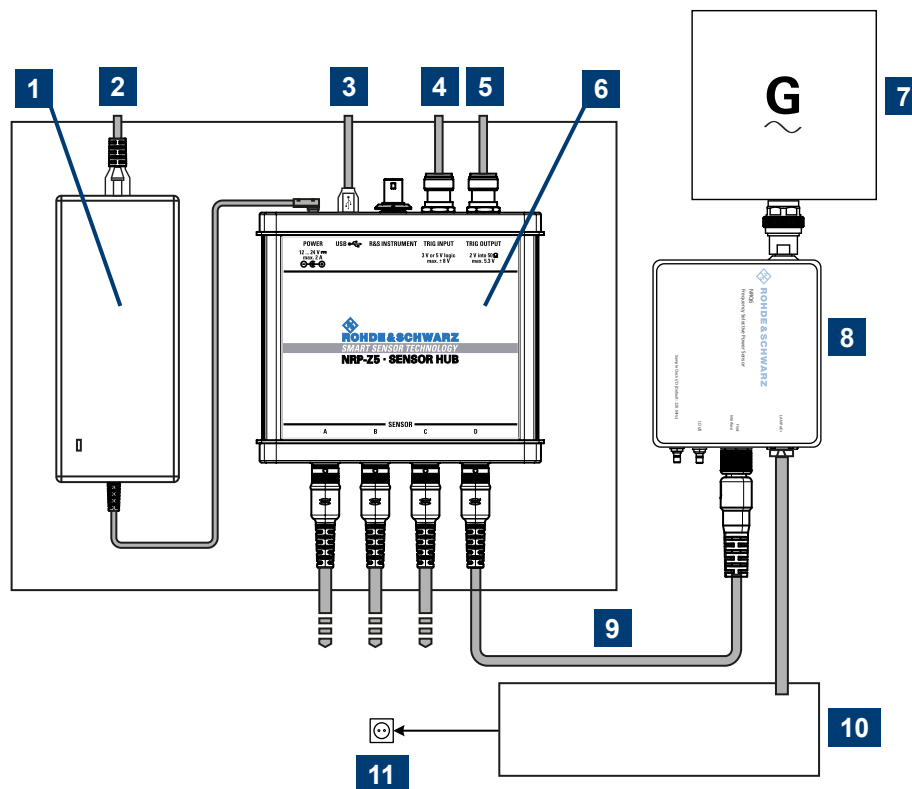

Figure 3-5: Configuration with an R&S NRP-Z5 sensor hub

- 1 = External power supply unit
- 2 = Connect to AC power supply
- 3 = Connect to computer with USB host interface
- 4 = Optional: Connect to trigger source

- 5 = Optional: Connect to triggered device
- 6 = R&S NRP-Z5 sensor hub
- 7 = Signal source (DUT)
- 8 = R&S NRQ6
- 9 = R&S NRP-ZK6 cable
- 10 = PoE+ injector
- 11 = AC power supply

1. Connect each R&S NRQ6 to:
 - a) Signal source (DUT), see [Chapter 3.4, "Connecting to a DUT"](#), on page 15.
 - b) Power supply, see [Chapter 3.5, "Connecting to a power supply"](#), on page 16.
 - c) R&S NRP-Z5 using a R&S NRP-ZK8 cable.
2. Connect the R&S NRP-Z5 to the computer using a USB cable.
3. Connect the delivered external power supply unit to the R&S NRP-Z5 and to an AC supply connector.
4. If you want to use an external trigger source, connect the trigger input of the R&S NRP-Z5 to the trigger source using a BNC cable.
5. If you want to use the trigger signal externally, connect the trigger output of the R&S NRP-Z5 to the trigger device using a BNC cable.

3.6.3 R&S NRX base unit

You can use an R&S NRX base unit as controlling host. Connect the R&S NRQ6 to the R&S NRX using the host interface. The R&S NRX supports the configuration of 2 directly connected R&S NRQ6, if enhanced accordingly. For details, see the user manual and the data sheet of the R&S NRX.

The R&S NRX supplies an external reference signal that is provided by the LVDS wire pair of the 8-pole sensor connector (M12).

Further information:

- [Table 9-2](#)
- [Chapter 5.3, "R&S NRX"](#), on page 39
- R&S NRX user manual

Setup

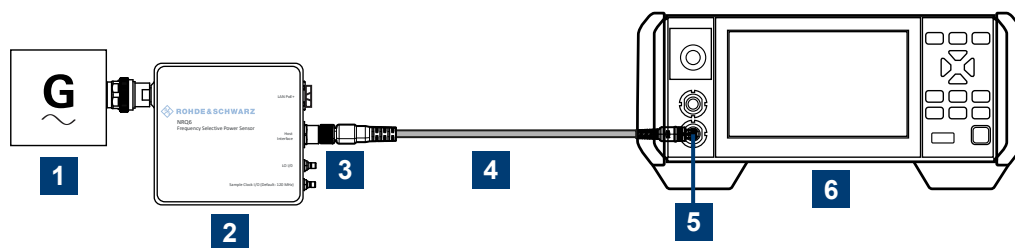

Figure 3-6: Setup with an R&S NRX base unit and one R&S NRQ6

- 1 = Signal source
- 2 = R&S NRQ6
- 3 = Host interface connector
- 4 = R&S NRP-ZK8 cable
- 5 = Sensor input connector of the R&S NRX
- 6 = R&S NRX base unit

Use an R&S NRP-ZK8 cable.

1. 8-pin female connector of R&S NRP-ZK8 cable:
 - a) Insert the screw-lock cable connector into the host interface of the R&S NRQ6.
 - b) Tighten the union nut manually.
 2. 8-pin male connector of R&S NRP-ZK8 cable:
 - a) Insert this connector into one of the sensor ports of the R&S NRX.
- If you want to disconnect the cable from the host interface of the R&S NRQ6:
- a) Loosen the union nut of the screw-lock cable connector.
 - b) Remove the cable.

4 R&S NRQ6 tour

This chapter provides an overview of the available connectors and LEDs of the R&S NRQ6.



Figure 4-1: R&S NRQ6 frequency selective power sensor

- 1 = RF connector, see [Chapter 4.1, "RF connector"](#), on page 27
- 2, 10 = Fan openings, see [Chapter 4.9, "Fan openings"](#), on page 31
- 3 = Status display, see [Chapter 4.2, "Status information"](#), on page 28
- 4 = LAN interface, see [Chapter 4.3, "LAN PoE+ interface"](#), on page 28
- 5 = Host interface, see [Chapter 4.4, "Host interface"](#), on page 30
- 6 = Local oscillator connector, see [Chapter 4.8, "Local oscillator I/O \(LO\)"](#), on page 31
- 7 = Sampling clock connector, see [Chapter 4.7, "Clock I/O \(CLK\)"](#), on page 31
- 8 = Trigger connector, see [Chapter 4.5, "Trigger 2 I/O \(TRIG2\)"](#), on page 30
- 9 = Reference clock, see [Chapter 4.6, "Reference I/O \(REF\)"](#), on page 30

4.1 RF connector

See (1) in [Figure 4-1](#).

The male N connector is used to connect the R&S NRQ6 to the device under test (DUT) or a signal generator, see [Chapter 3.4, "Connecting to a DUT"](#), on page 15.







For maximum measurement accuracy, tighten the RF connector using a torque wrench with the recommended nominal torque. For details, see ["To connect to the DUT"](#) on page 15.

4.2 Status information

See (2) in [Figure 4-1](#).

The status LED shows the state of the R&S NRQ6 by color and blinking frequency.

Table 4-1: Possible states

	Color	Illumination	State
	White	Steady	Idle The sensor performs no measurement and is ready for use.
	White	Blinking	Firmware update is in progress.
	Yellow	Steady	Waiting for trigger state.
	Green	Steady	Measurement is running.
	Turquoise blue	Steady	Zeroing is in progress.
	Red	Slow blinking	Static error
	Red	Fast blinking	Critical static error Note: If this state occurs after a firmware update, the update was not successful. See "Sensor blinks red after firmware update" on page 213.

Further information:

- [Chapter 15, "Troubleshooting"](#), on page 207.

4.3 LAN PoE+ interface

See (3) in [Figure 4-1](#).

1 Gigabit LAN interface (1000 Base-T). The assignment of the RJ.45 CAT5 connector supports twisted-pair UTP/STP cables in a star configuration (UTP stands for "unshielded twisted pair", and STP for "shielded twisted pair").



Electromagnetic interference (EMI) can affect the measurement results. To avoid any impact, use category 5 cables or better.

The power for the R&S NRQ6 is supplied over the LAN PoE+ interface.

The LAN PoE+ interface also connects the R&S NRQ6 to a local area network (LAN) for remote control, remote operation and data transfer.



R&S NRQ6 requires PoE+

The electrical power for the R&S NRQ6 is provided by PoE+, power over Ethernet. The IEEE 802.3at standard specifies 25.4 W per port. For details, see [Chapter 3.5, "Connecting to a power supply"](#), on page 16.

The power delivery at a USB host interface is not sufficient to run the R&S NRQ6 properly. Therefore, you cannot use it as power supply for the R&S NRQ6.

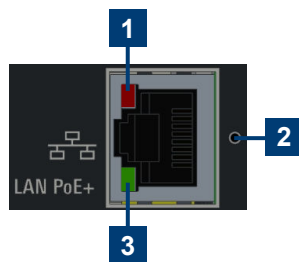

Figure 4-2: LAN [PoE+] interface

- 1 = Network status LED
- 2 = LAN reset button
- 3 = PoE+ status LED

Network status LED

See (1) in [Figure 4-2](#).

Shows whether the LAN connection to the network is established properly or not.

Color	State
Green	The power sensor is correctly connected to the network. It has been assigned a valid IP address, either manually or via DHCP.
Red	The power sensor is not connected to the network correctly. Either the connection is erroneous or the sensor has not been assigned a valid IP address yet.

PoE+ status LED

See (2) in [Figure 4-2](#).

Shows whether the R&S NRQ6 is correctly powered over PoE+ or not.

Color	State
Green	The sensor is powered over PoE+. You can operate it using the Ethernet interface.
No light	No PoE+ power is present.

LAN reset button

See (3) in [Figure 4-2](#).

Resets the Ethernet connection parameters of the power sensor to their default values.

After a LAN reset, the Ethernet interface is set DHCP mode where automatic address allocation is attempted.

4.4 Host interface

See (4) in [Figure 4-1](#).

The 8-pole male sensor connector (M12) is used to connect the R&S NRQ6 to a computer or an R&S NRX base unit.

Further information:

- [Chapter 3.6.1, "Computer using a LAN connection"](#), on page 17
- [Chapter 3.6.2, "Computer using a USB connection"](#), on page 22
- [Chapter 3.6.3, "R&S NRX base unit"](#), on page 25
- [Chapter 14.1, "Remote control interfaces and protocols"](#), on page 193

4.5 Trigger 2 I/O (TRIG2)

See (5) in [Figure 4-1](#).

The female SMA connector is used as an input or output for a trigger signal.

For input and output specifications, read the label on the R&S NRQ6 casing and the data sheet.

Further information:

- [Chapter 9.2, "Trigger settings"](#), on page 88.

4.6 Reference I/O (REF)

See (6) in [Figure 4-1](#).

The female SMA connector is used as an input or output for the reference clock.

By default, the R&S NRQ6 generates a 10 MHz reference signal and uses it as reference clock. You can use this signal as a reference clock for other devices (output).

Also, you can supply an external reference signal and use it as reference clock instead of the internal reference signal (input).

For input and output specifications, read the label on the R&S NRQ6 casing and the data sheet.

Further information:

- [Chapter 9.5, "Sensor settings"](#), on page 104.

4.7 Clock I/O (CLK)

See (7) in [Figure 4-1](#).

The female SMA connector is used as an input or output for the sampling clock. By default, the R&S NRQ6 generates its sampling clock internally. You can use this signal for other devices (output).

If you supply the local oscillator signal externally, you can use an external signal as sampling clock instead of the internal signal (input).

For input and output specifications, read the label on the R&S NRQ6 casing and the data sheet.

Further information:

- [Chapter 9.5, "Sensor settings"](#), on page 104.

4.8 Local oscillator I/O (LO)

See (8) in [Figure 4-1](#).

The female SMA connector is used as an input or output for the local oscillator (LO) signal.

For input and output specifications, read the label on the R&S NRQ6 casing and the data sheet.

Further information:

- [Chapter 9.4, "Mixer settings"](#), on page 101.

4.9 Fan openings

See (9, 10) in [Figure 4-1](#).

The R&S NRQ6 has fan openings on the top and on the bottom of the casing. When connecting the R&S NRQ6, be careful to allow sufficient airflow as specified in "[Allow sufficient airflow](#)" on page 15.

5 Operating concepts

For operating the R&S NRQ6, you can choose from the following possibilities:

- [Chapter 5.2, "Browser-based user interface"](#), on page 34
- [Chapter 5.3, "R&S NRX"](#), on page 39
- [Chapter 5.4, "Remote control"](#), on page 40

Also, the R&S NRQ6 is supported by the R&S Power Viewer. The R&S Power Viewer is provided on your documentation CD-ROM and on the Rohde & Schwarz website as a separate standalone installation package.

5.1 R&S NRP Toolkit



Before you start using the power sensor, we recommend to install the R&S NRP Toolkit.

The R&S NRP Toolkit is the basic software package that supplies low-level drivers and tools for all power sensors. The components of the R&S NRP Toolkit depend on the operating system.

5.1.1 Versions and downloads

The R&S NRP Toolkit is available for:

- Microsoft Windows operating systems, as listed in [Chapter 5.1.2, "System requirements"](#), on page 32
- Linux distributions
- macOS

Several R&S NRP Toolkit versions are available on your documentation CD-ROM. The latest version for Windows is available at www.rohde-schwarz.com/software/nrp-toolkit.

To obtain an R&S NRP Toolkit for an operating system other than Microsoft Windows, contact the Rohde & Schwarz customer support: customersupport@rohde-schwarz.com

5.1.2 System requirements

Hardware requirements:

- Desktop computer or laptop, or an Intel-based Apple Mac
- LAN interface and equipment for setting up a LAN connection.
See [Chapter 3.6.1, "Computer using a LAN connection"](#), on page 17.

Supported Microsoft Windows versions:

- Microsoft Windows Vista 32/64-bit
- Microsoft Windows 7 32/64-bit
- Microsoft Windows 8/ 8.1 32/64-bit
- Microsoft Windows 10 32/64-bit

5.1.3 R&S NRP Toolkit for Windows

The R&S NRP Toolkit installer for Windows-based systems contains the components described in the release notes available at www.rohde-schwarz.com/software/nrp-toolkit.

To install the R&S NRP Toolkit

1. Start the R&S NRP Toolkit installer on the Windows-based computer.
In the "NRP-Toolkit Setup" dialog, the correct R&S NRP Toolkit version for your operating system, 32-bit or 64-bit, is already selected.
2. Enable the components you want to install.
 - "NRP-Toolkit (SDK)"
The software development kit (SDK) provides programming examples for the R&S power sensors.
See [Chapter 13, "Programming examples"](#), on page 192.
 - "IVI Shared Components"
Installs the USBTMC driver. Enabled by default because the installation is recommended.
See also [Table 14-1](#).

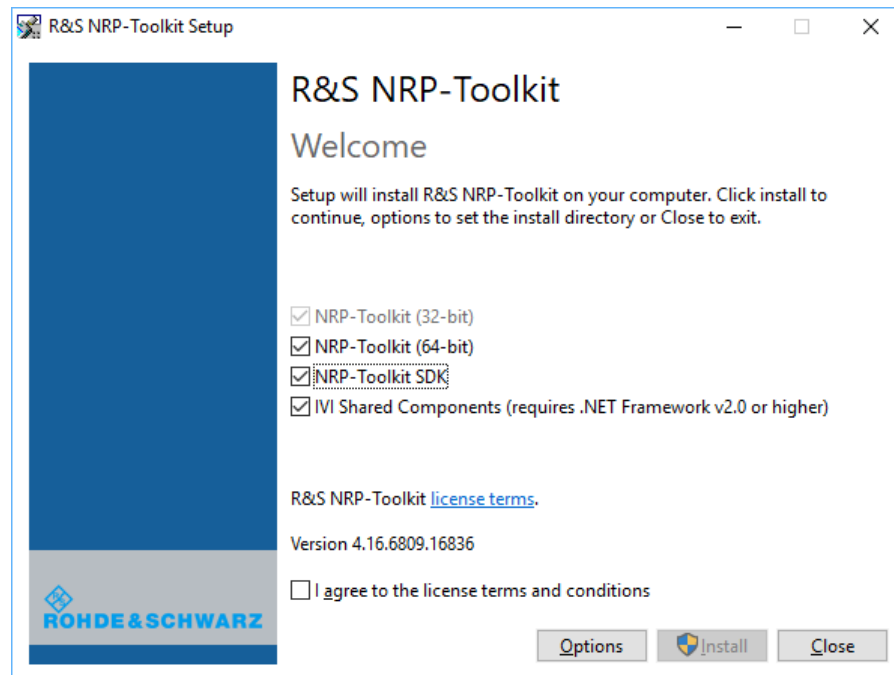

3. Accept the license terms to continue with the installation.
4. Click "Next" and complete the installation process.

5.1.3.1 Performing a firmware update

The Firmware Update for NRP Family program is part of the R&S NRP Toolkit for Windows. You can use the Firmware Update for NRP Family program to load new firmware for the power sensors.

For further details, refer to [Chapter 11, "Firmware update"](#), on page 112.

5.2 Browser-based user interface

With the integrated, browser-based graphical user interface of the R&S NRQ6, you can easily configure the settings and measure in the provided measurement modes. Open a web browser on your controlling host and connect to the R&S NRQ6. No extra installation is required.

Requirements

- Controlling host:
You can use the web user interface with all devices and operating systems, including tablets and smart phones.
- Supported web browser:
 - Mozilla Firefox 56 or later
 - Google Chrome 61 or later

- Microsoft Internet Explorer 11 or later
- Microsoft Edge 40

Setup

1. Set up a LAN connection.
For an example, see [Chapter 3.6.1, "Computer using a LAN connection"](#), on page 17.
Note: Make sure to power the R&S NRQ6 with PoE+. See ["R&S NRQ6 requires PoE+"](#) on page 29.
2. Connect the R&S NRQ6 to the DUT as described in [Chapter 3.4, "Connecting to a DUT"](#), on page 15.

To display the Web user interface

1. Open a supported web browser.
2. Enter the hostname of the R&S NRQ6 you want to connect to. See [Chapter 3.6.1.5, "Using hostnames"](#), on page 21.
Example: If the hostname is *nrq6-900045*, enter *http://nrq6-900045*.
You can also use the IP address, see [Chapter 3.6.1.6, "Assigning the IP address"](#), on page 22.
The main dialog of the web user interface opens. See also [Figure 5-1](#).

Reloading the web browser page

After a firmware update or a reboot, you need to reload the web browser page.

- ▶ Press [F5].

Parameter description

The parameters of the web user interface are described together with background information in the following chapters:

- [Chapter 7, "Adapting to the test signal"](#), on page 49
- [Chapter 8, "Measurement modes and result displays"](#), on page 61
- [Chapter 9, "Measurement configuration"](#), on page 82
- [Chapter 10, "System configuration"](#), on page 107

5.2.1 Layout of the main dialog

The main dialog of the web user interface gives access to all available settings.



Figure 5-1: Layout of the web user interface

- 1 = Navigation pane
- 2 = Sensor name or hostname
- 3 = Status information
- 4 = Sensor information
- 5 = Top pane
- 6 = Settings pane
- 7 = Result pane

Sensor name or hostname

(1) in [Figure 5-1](#)

If you do not specify a sensor name, the hostname is displayed.

See ["Sensor Name"](#) on page 109.

Status information

(2) in [Figure 5-1](#)

Displays the status of the R&S NRQ6. The colors are explained in [Chapter 4.2, "Status information"](#), on page 28.

You can also display detailed information.

See [Chapter 15.2, "Error messages"](#), on page 207.

If the R&S NRQ6 is in remote mode, the status is displayed next to the status LED, see [Figure 5-2](#).

Sensor information

(3) in [Figure 5-1](#)

Serial number of the R&S NRQ6 and installed firmware version

Top pane

(4) in [Figure 5-1](#)

Stays always visible.

See [Chapter 7, "Adapting to the test signal"](#), on page 49.

Navigation pane

(5) in [Figure 5-1](#)

For displaying measurement and system settings in the settings pane.

Settings pane

(6) in [Figure 5-1](#)

Displays the settings you have selected in the navigation pane.

Result pane

(7) in [Figure 5-1](#)

Displays the result for the selected measurement mode.

See [Chapter 8, "Measurement modes and result displays"](#), on page 61.

5.2.2 Tooltips

The web user interface provides tooltips on parameter functions and remote control commands.

If you place the cursor over the name of a parameter field, a short description of the parameter function is displayed.

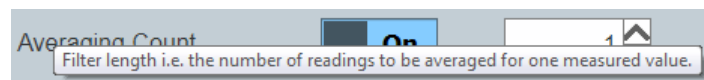





If you place the cursor over a parameter field, the short form of the corresponding remote control command is displayed.

**5.2.3 Toolbar in charts**

If you move the mouse into a chart, a toolbar becomes visible in the upper right corner. Use the toolbar to analyze the chart in detail.

Table 5-1: Icons for chart analysis

Icon	Description
	Downloads the chart in PNG format.
	Zooms into the selected window.
	Moves the chart in the direction of both axes.
	Resets the axes.

5.2.4 Setting parameters

If a parameter is not grayed, you can change its setting.

To enter quantities with units

The default unit is displayed next to the parameter field, for example:

5.038886599 GHz

1. If you enter just a number, the default unit remains.
Example: 2 + [ENTER] -> 2 GHz
2. If you enter the number with a short form of the unit, the short form overrules the default unit.

Examples:

- 123M + [ENTER] -> 123 MHz
- 1234M + [ENTER] -> 1.234 GHz (= 1234 MHz)

See [Table 5-2](#) for the available short forms of units.

Table 5-2: Short forms of units

Quantity	Short forms *	Corresponding unit
Frequency	G	GHz
	M	MHz
	K	kHz
	H	Hz
Time	S	s
	M	ms
	U	µs
	N	ns
	P	ps
* Both capital and small letters are accepted.		



- ▶ If you want to change a number, you can also:
 - Use the spinner. One click changes the number by one increment. If you keep the arrow pressed, you can quickly scroll through the possible values.
 - Use the right or left arrow key of your keyboard. Select the digit you want to change. Press the key.

To select a parameter value from a list

1. Click ▼ to open the list.
A list with all available values is displayed.
2. Click a value to select it.
The change takes effect immediately.

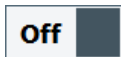

To toggle between two possible values

If only two values are possible, you can toggle between these values. Toggling works for the pairs "Off"/"On", "Auto"/"Manual", "Left"/"Right", etc.

- ▶ Click the value to change to the other value.

5.3 R&S NRX

In a measurement, the R&S NRX uses all power sensor-dependent measurement functions and displays the results. Thus, you can configure both the measurement and the power sensor.

Setup

1. Connect the power sensor to the R&S NRX.
See [Chapter 3.6.3, "R&S NRX base unit"](#), on page 25.
2. Connect the power sensor to the signal source.
See [Chapter 3.4, "Connecting to a DUT"](#), on page 15.

Starting a measurement

For a detailed description of how to measure in this setup, refer to the user manual of the R&S NRX.

1. Preset the R&S NRX and the connected R&S power sensors.
 - a) Press the [Preset] key.
 - b) Tap "Preset".
All parameters are set to their defaults.
2. If measuring in zero-IF mode (RBW > 40 MHz), consider to zero the power sensor:

Note: Turn off all measurement signals before zeroing. An active measurement signal during zeroing causes an error.

 - a) Switch off the power of the signal source.

- b) Press the [Zero] key of the R&S NRX.
 - c) Tap "Zero All Sensors".
3. Configure the measurement.
 - a) In the "Measurement Settings" dialog, select the "Measurement Type", for example "Continuous Average".
 - b) Tap "Quick Setup" > "Auto Set".
4. Switch on the signal source.
The measurement starts, and the result is displayed in dBm.
5. If necessary, perform further settings.

5.4 Remote control

You can remote control the R&S NRQ6 easily. The change to remote control occurs "on the fly".

Switching to remote control

1. Establish a link between the controller and the R&S NRQ6.
2. Send a SCPI command to the R&S NRQ6.

The R&S NRQ6 changes into remote mode.

The web user interface is locked and becomes darker. The status is displayed next to the status LED.

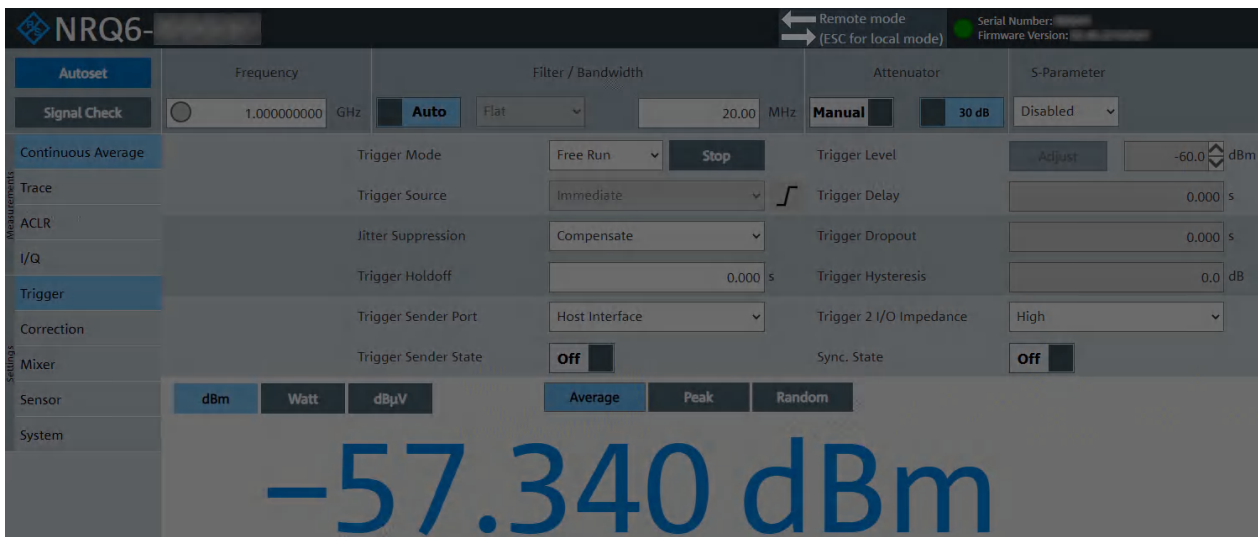

Figure 5-2: Locked web user interface during remote control

Returning to manual operation (local)

- ▶ Press [Esc] at the controller keyboard.

The R&S NRQ6 changes into local mode. The lock of the web user interface is removed.

Further information:

- [Chapter 12, "Remote control commands"](#), on page 118
- [Chapter 14, "Remote control basics"](#), on page 193
- [Chapter 3.6, "Connecting to a controlling host"](#), on page 17

6 Measurement basics

- [Functional principle](#)..... 42
- [Measurement procedure in principle](#)..... 42
- [Measurement duration](#)..... 43
- [Improving measurement results](#)..... 44
- [Impact of measurement parameters on noise](#)..... 44
- [Potential sources of error](#)..... 46

6.1 Functional principle

The R&S NRQ6 is a receiver-based power sensor.

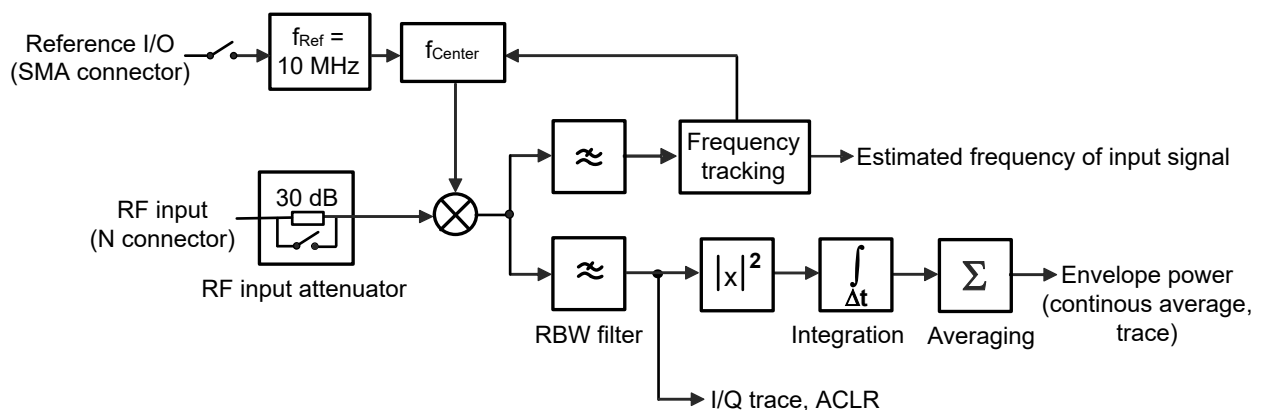

Figure 6-1: Signal flow from the RF input to the result processing

RBW is the resolution bandwidth as known from spectral analysis. If measuring with an $RBW > 40$ MHz, the R&S NRQ6 works in zero-IF mode.

6.2 Measurement procedure in principle

Unlike thermal or diode-based power sensors, the R&S NRQ6 is frequency selective. That means, you go about measuring differently than you are accustomed from the conventional power sensors.

To prepare and start a measurement

1. Take the test signal and its properties into account.
See [Chapter 7, "Adapting to the test signal"](#), on page 49.
2. Select the measurement mode.
See [Chapter 8, "Measurement modes and result displays"](#), on page 61.
3. Configure the measurement by selecting trigger settings, averaging, aperture time etc.

See [Chapter 8, "Measurement modes and result displays"](#), on page 61 and [Chapter 9, "Measurement configuration"](#), on page 82.

4. For broadband measurements (RBWs > 40 MHz), perform DC zeroing.
See [Chapter 9.3.2.2, "DC zeroing"](#), on page 98.
5. Start the measurement.

To get measurement results quickly, the R&S NRQ6 offers numerous autoset features. In the web user interface, several settings are bundled together and controlled by an "Autoset" button. In remote control, each automatic setting is executed by a separate command.

To end a measurement

If the "Free Run" trigger mode is set, the measurement runs continuously.

- ▶ Next to "Trigger Mode", click "Stopp".

6.3 Measurement duration

The total measurement time is determined as follows:

Filter settling time + aperture time x averaging = total measurement duration

Filter settling time

Defined by the resolution bandwidth filter. You select this filter by selecting the resolution bandwidth and optionally a filter type if not chosen automatically.

A smaller resolution bandwidth causes a larger filter settling time. The filter type also influences the resulting settling time, see also [Chapter 7.3, "Resolution bandwidth filters"](#), on page 52.

Aperture time

Available as a measurement parameter. However, the effectively resulting aperture time is always a multiple of the sampling period time interval defined by the resolution bandwidth filter.

If you measure periodic signals, set the aperture time to the signal period. Thus, the power fluctuations are averaged, and the measurement result becomes stable immediately.

Averaging

For non-periodic signals, disable averaging entirely and choose the aperture time according to the desired total measurement duration. This approach is most efficient since it minimizes any waiting or processing times in the sensor.

For periodic signals, the measurement result attains its maximum stability for a fixed aperture time. Thus, adjust the total measurement duration using the averaging count.

6.4 Improving measurement results

With the following measures, you can counteract the influencing factors on the measurement results.

How to reduce the measurement noise contributions corresponding to the fluctuations of the measurement result?

- ▶ Increase the total measurement duration.

How to reduce noise-like contributions that are caused by spurious and interference signals?

- ▶ Reduce the resolution bandwidth.
- ▶ Increase the total measurement duration. This measure can help but it does not guarantee any improvement.

How to reduce a measurement bias that is caused by the noise floor or spurious signals in the analysis bandwidth?

- ▶ Decrease the resolution bandwidth.
- ▶ Use log-power averaging (`[SENSe<Sensor>:]AVERage:TYPE VIDEo`).

Within the specified measurement uncertainty, measurement offsets of the sensor are always present.

6.5 Impact of measurement parameters on noise

The following parameters mainly determine the fluctuation of measurement results due to noise:

- Measured power level
- Input attenuator state
- Total measurement duration

Note that the selected resolution bandwidth filter does not influence the measurement noise directly. However, the resolution bandwidth must be small enough so that the noise power is sufficiently below the measured value.

[Figure 6-2](#) and [Figure 6-3](#) compare the R&S NRQ6 with a conventional 3-path-diode sensor that has a class leading dynamic range. Unlike the 3-path diode sensor, the R&S NRQ6 has no auto-averaging feature. Therefore, you have to define the measurement time manually when measuring with the R&S NRQ6.

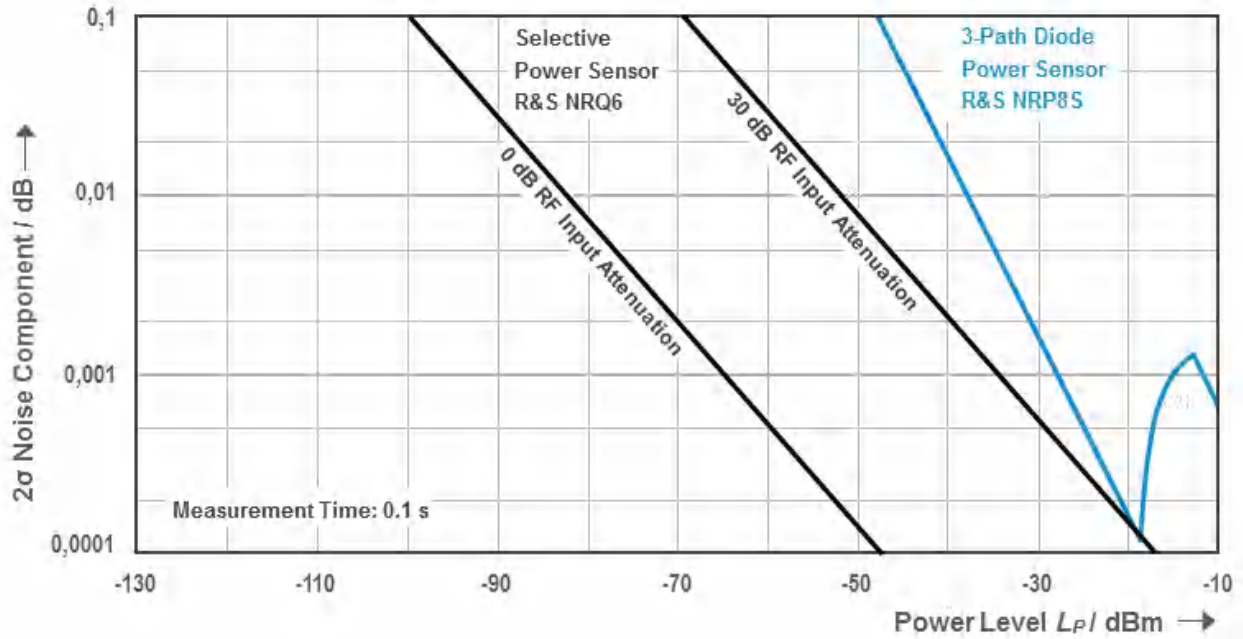

Figure 6-2: Measurement noise

Figure 6-2 shows the resulting noise contribution for a fixed measurement time of 0.1 s, assuming that the filter settling time is far smaller than the integration time and that the noise floor power is much smaller than the power level.

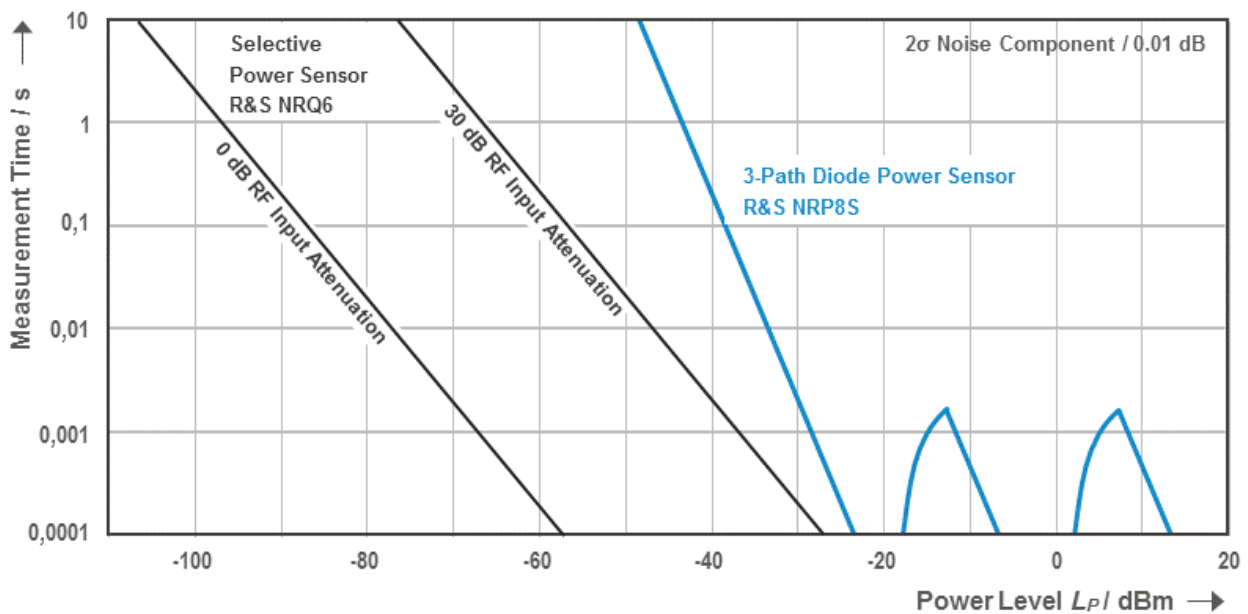

Figure 6-3: Measurement time for CW signal

Figure 6-3 shows the resulting measurement time for a fixed noise contribution of 0.01 dB (2σ), assuming that the filter settling time is far smaller than the integration time and that the noise floor power is much smaller than the power level.

Measurement time = integration time + RBW filter settling time

6.6 Potential sources of error

- Spurious response frequencies.....46
- LO leakage.....47

6.6.1 Spurious response frequencies

The hardware design of the R&S NRQ6 differs fundamentally from a spectrum analyzer. Therefore, the R&S NRQ6 cannot provide a similar level of spurious response rejection. For isolated signals with small bandwidths and correctly specified measurement frequencies, that is no problem. It can be assumed that no signal is present at the spurious response frequencies of the sensor. But in the following situations, the measurement result can be corrupted:

- The maximum frequency and the minimum frequency of an input signal are spread by more than a factor of two ($f_{\max} > 2 * f_{\min}$).
- The measurement frequency is set to a value outside of the signal frequency span

The spurious response frequencies and their corresponding attenuation level vary with the measurement frequency, the resolution bandwidth and the RF input attenuator setting of the R&S NRQ6.

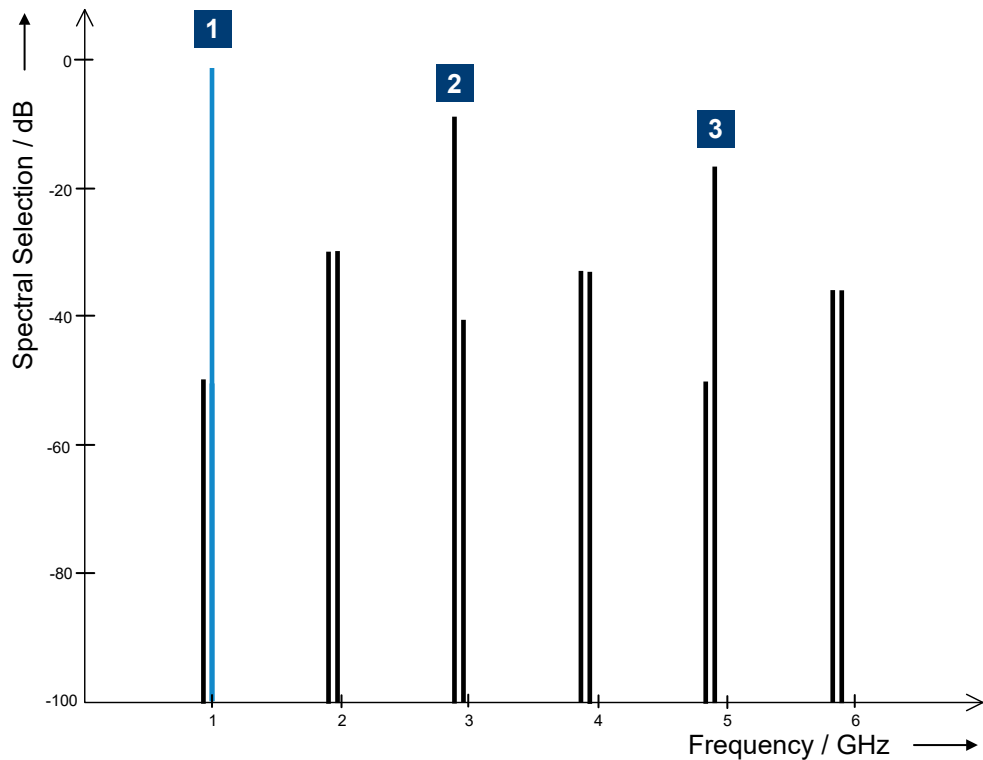

Figure 6-4: Typical spurious response of R&S NRQ6 set at 1 GHz input frequency, 20 MHz resolution bandwidth and right sideband

- 1 = 1st harmonic (right sideband: 1 GHz)
- 2 = 3rd harmonic (left sideband: 2.900 GHz)
- 3 = 5th harmonic (right sideband: 4.900 GHz)

For the 3rd harmonic, the image suppression of the left sideband is about 9.5 dBc. For the 5th harmonic, the image suppression of the right sideband is about 14 dBc. The exact value depends on the frequency response of the R&S NRQ6.

6.6.2 LO leakage

In a receiver-based power sensor, signal leakage paths can occur. Local oscillator (LO) energy can leak through the mixer stage and the RF connection into DUT. In [Figure 6-5](#), this LO leakage is symbolized by the blue arrow.

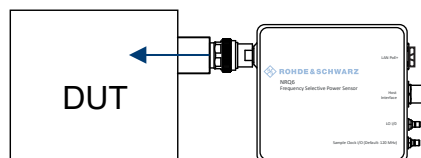

Figure 6-5: LO leakage into the DUT

These emissions have the frequency of the local oscillator or a multiple of it, the harmonics. The emissions can lead to mixing products in the DUT. For example if the DUT

is a signal generator with level control, the LO leakage of the R&S NRQ6 can lead to a wrong level setting.

Example: LO frequency and harmonics

Settings:

- Carrier frequency of the applied signal: 800 MHz
(`[SENSe<Sensor>:]FREQuency[:CENTer]`)
- LO frequency: 825 MHz
(`[SENSe<Sensor>:]FREQuency:CONVersion:MIXer:LO[:CUV]?`)
- Distance between carrier frequency and LO frequency: ~25 MHz
(`[SENSe<Sensor>:]FREQuency:CONVersion:MIXer:IF[:CUV]?`)

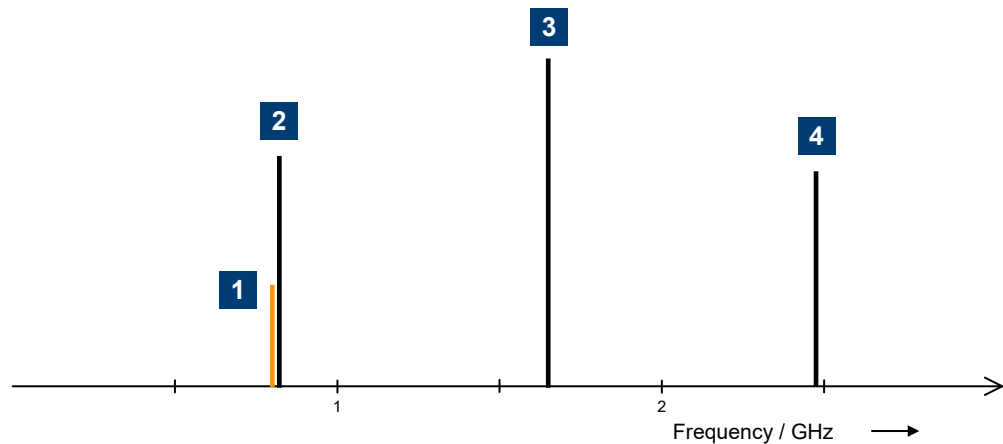

- 1 = Carrier frequency (800 MHz)
 2 = LO frequency (825 MHz)
 3 = 2nd LO harmonic (1.65 GHz)
 4 = 3rd LO harmonic (2.475 GHz)

The LO leakage up to 6 GHz is specified in the data sheet. The diagram below roughly visualizes the specification.

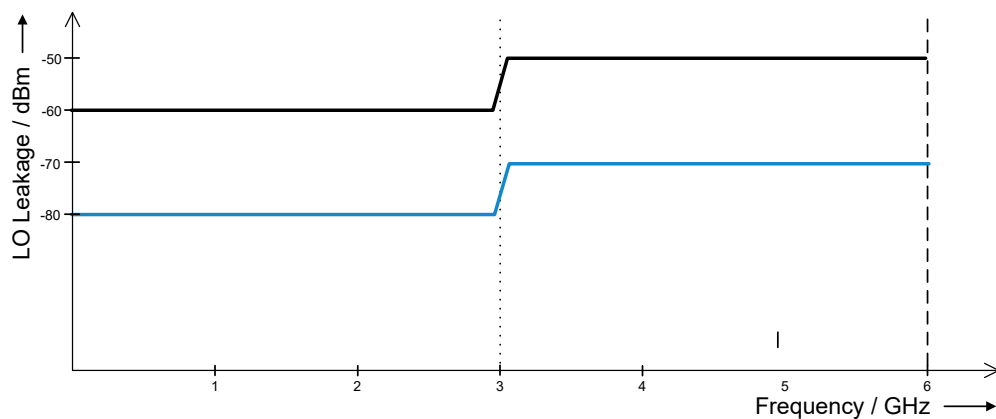

The black line represents the LO leakage at 0 dB RF attenuation. The blue line represents the LO leakage at 30 dB RF attenuation.

7 Adapting to the test signal

The R&S NRQ6 is a frequency selective power sensor. Before starting a measurement, you need to take the test signal and its properties into account.

You can do that either automatically by using the autosest function, or by setting the frequency, filter, bandwidth and attenuation manually. With the help of the signal check, you can check whether the signal you want to measure the power of is included in the selected bandwidth. The in-built frequency tracker keeps the focus on the test signal, even when the signal shifts over time. This feature is especially useful for narrowband signals, see [Chapter 7.2.2, "Frequency adjustment for narrowband measurements"](#), on page 51.

Further information:

- [Chapter 5.2.1, "Layout of the main dialog"](#), on page 35

Remote command reference:

- [Chapter 12.3, "Adapting to the test signal"](#), on page 123

Web user interface:

- [Chapter 7.5, "Top pane parameters"](#), on page 57

Contents:

• Automatic settings	49
• Frequency configuration	50
• Resolution bandwidth filters	52
• RF input attenuation	56
• Top pane parameters	57

7.1 Automatic settings

The automatic settings (autosest) function makes the crucial measurement settings for you. Thus, also unknown signals are recognized and their average power can be measured.

The autosest function performs the following actions:

- Automatically adjusts the frequency.
- Optimizes the filter settings. See [Chapter 7.3.2, "Automatic filter type selection"](#), on page 53.
- Automatically adjusts the input attenuation. See ["Attenuator"](#) on page 59.
- If using the web user interface, also the following happens:
 - In trace mode, also performs the auto settings specific for trace mode. See ["Autosest"](#) on page 67.
 - Starts the measurement.

You can also adjust the settings manually, see [Chapter 7.5, "Top pane parameters"](#), on page 57.

7.2 Frequency configuration

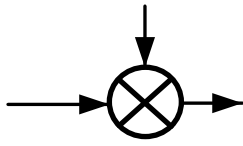

If you do not use the autoselect function, the frequency of the test signal is not automatically determined.

The center frequency defines the mixing frequency in the downconversion process. Signals outside of the analysis bandwidth are filtered out. However, the R&S NRQ6 is sensitive to signals at frequencies related to the harmonics of the conversion frequency. These spurious response frequencies are usually attenuated by more than 10 dB compared to the desired measurement frequency. See [Chapter 6.6.1, "Spurious response frequencies"](#), on page 46.

7.2.1 Frequency tracker

The R&S NRQ6 offers an in-built frequency tracker. The frequency tracker is available for bandwidths ≤ 10 MHz. The frequency tracker is suitable to correct slow drifts and constant offsets for CW signal levels of 20 dB above the noise floor.

You can enable or disable the frequency tracker using:

- Remote command: `[SENSe<Sensor>:]FREQuency:TRACk` on page 174
- Web user interface: "Switch" on page 104

The frequency tracking range is based on the specified center frequency. The bandwidth of the frequency tracking range is ≤ 30 MHz. It is a multiple of the resolution bandwidth as shown in [Table 7-1](#).

Table 7-1: Correlation of resolution bandwidths

RBW	Tracking range
10 Hz to 100 Hz	30 kHz
200 Hz to 300 Hz	100 kHz
500 Hz to 1 kHz	300 kHz
2 kHz to 3 kHz	1 MHz
5 kHz to 10 kHz	3 MHz
20 kHz to 30 kHz	10 MHz
50 kHz to 10 MHz	30 MHz
> 10 MHz	-

The R&S NRP Toolkit provides program examples on this topic.

Further details:

- [Chapter 5.1, "R&S NRP Toolkit"](#), on page 32

- [Chapter 13, "Programming examples"](#), on page 192

7.2.2 Frequency adjustment for narrowband measurements

For small resolution bandwidths, oscillator offsets, drifts or phase noise contributions can corrupt the measurement results. Therefore, you have to take additional measures by using one of the following options. The requirements are summarized in [Table 7-2](#).

Synchronizing the reference frequencies - external clock reference

You can synchronize the reference frequencies of the R&S NRQ6 and the signal source. Make sure that center frequency is specified accurately.

Use the REF connector of the R&S NRQ6 to lock the R&S NRQ6 to the reference frequency of the signal source or vice versa.

Further information:

- [Table 9-2](#)
- [Chapter 4.6, "Reference I/O \(REF\)"](#), on page 30

Controlling the center frequency - frequency tracker

See [Chapter 7.2.1, "Frequency tracker"](#), on page 50.

Adjusting the frequency settings - autosest function

Applicable if the drifts are:

- Small
Thus preventing that the signal source and the power sensor reference frequencies diverge too much.
- Slow
You can perform the autosest repeatedly.

You can use the autosest only if the signal level is high enough. Only CW signal levels above -65 dBm can be identified. For modulated signals, the minimum power must be even larger to discriminate the signal from the noise floor correctly.

Table 7-2: Requirements

	External clock reference	Frequency tracker	Autosest function
Specification of measurement frequency	Accurate value	Approximate value	Automatic setting
Specification of bandwidth	Approximate	Approximate	Automatic setting
DUT must provide reference frequency	Yes	No	No

	External clock reference	Frequency tracker	Autoset function
Compensation of offset and drift	Yes	Yes	No Slow drifts can be handled by calling autoset repeatedly.
Minimum power level at minimum bandwidth	-130 dBm	-120 dBm	-65 dBm

7.3 Resolution bandwidth filters

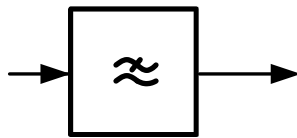

The R&S NRQ6 supports different filter types. Each filter type is optimized for a different goal. Thus, it is possible to adapt the R&S NRQ6 to various measurement situations.

7.3.1 Filter characteristics

Table 7-3: Characteristics overview

Filter characteristic	Rectangular	Gaussian
Filter type	Flat, LTE, 3GPP	Normal
Optimized for	Flat passband	Short filter response
Overshoot in power domain	Not specified	≤ 5 %
Filter response at ±0.5*RBW	0 dB (flat passband)	-3 dB
Max. RBW setting	100 MHz	400 MHz (rise time ≤ 2 ns)
Min. BW	100 Hz	10 Hz
Filter response	≤ 0.44 s	≤ 0.28 ms

Rectangular filter type

Possesses a flat passband with a nearly linear phase response. If the signal bandwidth does not exceed the passband bandwidth, the signal shape is not affected by the filter. Otherwise, the filter reduces the bandwidth of the signal. In this case, the steep filter edges can easily lead to overshoot features at transitions. For information on available filter bandwidths, see [Table 7-4](#).



Gaussian filter type

Genuine Gaussian filters with various 3 dB bandwidths. Gaussian filters possess a comparably short impulse response, which makes the Gaussian filter advantageous for very short measurement times. The settling time that subtracts from the total measurement time is minimized, and the effective measurement time is maximized. As a side effect, the shortest possible measurement time is decreased. Since the filter is not flat, the power of the input signal decreases away from the center frequency. The spectral components in the middle of the filter are correctly leveled. Furthermore, the filter is smooth both in the frequency and in the time domain. Therefore, no significant overshoot is caused by the filter. For information on available filter bandwidths, see [Table 7-4](#).

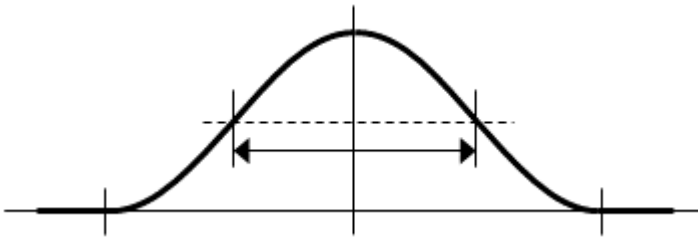

7.3.2 Automatic filter type selection

In many situations, it is appropriate to let the R&S NRQ6 automatically choose the filter type for the measurement. The selection process is based on the currently selected measurement mode and, for some modes, also on the resolution bandwidth.

Measurement mode	Filter type	Resolution bandwidth (RBW), see "<Bandwidth>" on page 59	
		Entered value	Currently used value
Continuous average Power servoing	"Normal"	value \leq 7.5 kHz or value \geq 250 MHz	value < 10 kHz or value = 400 MHz
	"Flat"	7.5 kHz < value < 250 MHz	10 kHz \leq value \leq 100 MHz
Trace	"Normal"		
I/Q trace	"Normal"		
ACLR	"LTE"	value > 4.42 MHz	value \geq 5 MHz
	"3GPP"	value \leq 4.42 MHz	value < 5 MHz

7.3.3 Choosing the correct filter type

You can choose from a large variety of filters, as listed in [Table 7-4](#). Not every filter type is suitable for every measurement.

For an EVM analysis, use a flat filter type. The LTE and 3GPP filter types are optimized for ACLR measurements.

For trace measurements with long trace length and high resolution bandwidth, you need to give attention to the output sample rate of the filter, given in [Table 7-4](#). For example, when measuring short pulses. If you choose a filter with a high output sample rate, the resulting amount of data can become too huge for the R&S NRQ6 to process. The R&S NRQ6 indicates this condition by a static error due to insufficient memory. Therefore, it is useful to query for static errors after setting all parameters to recognize an insufficient memory condition: `SYSTem:SERRor?`.

[Table 7-4](#) summarizes the following filter characteristics:

- **RBW display value**
This nominal value is used to select the desired filter.
- **Rise time**
Refers to the time which passes until the signal power rises from 10% to 90% when the filter is exposed to a unit step.
- **Settling time**
When measuring, the total measurement time consists of two parts. First, you need to consider the response time of the filter to let the filter attain a steady state. After this settling process, all samples in a predefined measurement interval – usually the aperture time - are used to compute the final measurement value.

Query the information about the currently active filter using `[SENSe<Sensor>:]BANDwidth:INFO?`.

Table 7-4: Filter characteristics at a given bandwidth

Filter type	Entered RBW	Pass BW	3 dB BW	Stop BW	Output sample rate	Rise time	Filter settling time	Equivalent noise BW
Flat	100 MHz	100.0 MHz	106.0 MHz	160.0 MHz	120.0 MHz	11.0 ns	375.0 ns	107.4 MHz
Flat	80 MHz	80.0 MHz	88.9 MHz	97.8 MHz	120.0 MHz	9.9 ns	900.0 ns	88.4 MHz
Flat	40 MHz	40.0 MHz	44.4 MHz	48.9 MHz	60.0 MHz	15.6 ns	1.4 µs	44.1 MHz
Flat	20 MHz	20.0 MHz	22.2 MHz	24.4 MHz	40.0 MHz	32.9 ns	2.0 µs	21.4 MHz
Flat	10 MHz	10.0 MHz	12.5 MHz	15.0 MHz	30.0 MHz	54.4 ns	4.7 µs	12.5 MHz
Flat	5 MHz	5.0 MHz	6.3 MHz	7.5 MHz	15.0 MHz	108.4 ns	9.0 µs	6.2 MHz
Flat	3 MHz	3.0 MHz	3.8 MHz	4.5 MHz	10.0 MHz	180.4 ns	13.3 µs	3.7 MHz
Flat	2 MHz	2.0 MHz	2.5 MHz	3.0 MHz	6.0 MHz	270.4 ns	22.0 µs	2.5 MHz
Flat	1 MHz	1.0 MHz	1.3 MHz	1.5 MHz	3.0 MHz	540.7 ns	43.7 µs	1.2 MHz
Flat	500 kHz	500.0 kHz	625.0 kHz	750.0 kHz	1.5 MHz	1.1 µs	87.0 µs	624.0 kHz
Flat	300 kHz	300.0 kHz	375.0 kHz	450.0 kHz	909.1 kHz	1.8 µs	143.3 µs	374.6 kHz
Flat	200 kHz	200.0 kHz	250.0 kHz	300.0 kHz	600.0 kHz	2.7 µs	217.0 µs	249.6 kHz

Filter type	Entered RBW	Pass BW	3 dB BW	Stop BW	Output sample rate	Rise time	Filter settling time	Equivalent noise BW
Flat	100 kHz	100.0 kHz	125.0 kHz	150.0 kHz	300.0 kHz	5.4 µs	433.7 µs	124.8 kHz
Flat	50 kHz	50.0 kHz	62.5 kHz	75.0 kHz	150.0 kHz	10.8 µs	867.0 µs	62.4 kHz
Flat	30 kHz	30.0 kHz	37.5 kHz	45.0 kHz	90.1 kHz	18.0 µs	1.4 ms	37.4 kHz
Flat	20 kHz	20.0 kHz	25.0 kHz	30.0 kHz	60.0 kHz	27.0 µs	2.2 ms	25.0 kHz
Flat	10 kHz	10.0 kHz	12.5 kHz	15.0 kHz	30.0 kHz	54.1 µs	4.3 ms	12.5 kHz
Flat	5 kHz	5.0 kHz	6.3 kHz	7.5 kHz	15.0 kHz	108.1 µs	8.7 ms	6.2 kHz
Flat	3 kHz	3.0 kHz	3.8 kHz	4.5 kHz	9.0 kHz	180.2 µs	14.4 ms	3.7 kHz
Flat	2 kHz	2.0 kHz	2.5 kHz	3.0 kHz	6.0 kHz	270.3 µs	21.7 ms	2.5 kHz
Flat	1 kHz	1.0 kHz	1.3 kHz	1.5 kHz	3.0 kHz	540.7 µs	43.3 ms	1.2 kHz
Flat	500 Hz	500.0 Hz	625.0 Hz	750.0 Hz	1.5 kHz	1.1 ms	86.7 ms	624.0 Hz
Flat	300 Hz	300.0 Hz	375.0 Hz	450.0 Hz	900.0 Hz	1.8 ms	144.4 ms	374.4 Hz
Flat	200 Hz	200.0 Hz	250.0 Hz	300.0 Hz	600.0 Hz	2.7 ms	216.7 ms	249.6 Hz
Flat	100 Hz	100.0 Hz	125.0 Hz	150.0 Hz	300.0 Hz	5.4 ms	433.3 ms	124.8 Hz
Normal*	400 MHz	-	400.0 MHz	2.0 GHz	120.0 MHz	2.0 ns	375.0 ns	543.7 MHz
Normal	50 MHz	-	50.0 MHz	100.0 MHz	120.0 MHz	13.3 ns	900.0 ns	50.0 MHz
Normal	25 MHz	-	25.0 MHz	51.7 MHz	120.0 MHz	24.9 ns	900.0 ns	25.1 MHz
Normal	10 MHz	-	10.0 MHz	51.4 MHz	120.0 MHz	56.3 ns	633.3 ns	10.6 MHz
Normal	5 MHz	-	5.0 MHz	25.7 MHz	40.0 MHz	112.3 ns	900.0 ns	5.3 MHz
Normal	3 MHz	-	3.0 MHz	15.4 MHz	24.0 MHz	187.0 ns	1.3 µs	3.2 MHz
Normal	2 MHz	-	2.0 MHz	10.3 MHz	20.0 MHz	280.2 ns	1.7 µs	2.1 MHz
Normal	1 MHz	-	1.0 MHz	5.1 MHz	8.0 MHz	560.5 ns	3.2 µs	1.1 MHz
Normal	500 kHz	-	500.0 kHz	2.6 MHz	5.5 MHz	1.1 µs	6.0 µs	532.9 kHz
Normal	300 kHz	-	300.0 kHz	1.5 MHz	3.2 MHz	1.9 µs	9.8 µs	319.6 kHz
Normal	200 kHz	-	200.0 kHz	1.0 MHz	2.1 MHz	2.8 µs	14.8 µs	213.3 kHz
Normal	100 kHz	-	100.0 kHz	514.5 kHz	1.0 MHz	5.6 µs	29.3 µs	106.6 kHz
Normal	50 kHz	-	50.0 kHz	257.2 kHz	517.2 kHz	11.2 µs	58.3 µs	53.3 kHz
Normal	30 kHz	-	30.0 kHz	154.3 kHz	309.3 kHz	18.7 µs	94.1 µs	32.0 kHz
Normal	20 kHz	-	20.0 kHz	102.9 kHz	206.2 kHz	28.0 µs	141.0 µs	21.3 kHz
Normal	10 kHz	-	10.0 kHz	51.4 kHz	102.9 kHz	56.0 µs	282.1 µs	10.7 kHz
Normal	5 kHz	-	5.0 kHz	25.7 kHz	51.5 kHz	112.1 µs	563.9 µs	5.3 kHz
Normal	3 kHz	-	3.0 kHz	15.4 kHz	30.9 kHz	186.8 µs	939.5 µs	3.2 kHz
Normal	2 kHz	-	2.0 kHz	10.3 kHz	20.6 kHz	280.2 µs	1.4 ms	2.1 kHz

Filter type	Entered RBW	Pass BW	3 dB BW	Stop BW	Output sample rate	Rise time	Filter settling time	Equivalent noise BW
Normal	1 kHz	-	1.0 kHz	5.1 kHz	10.3 kHz	560.4 μ s	2.8 ms	1.1 kHz
Normal	500 Hz	-	500.0 Hz	2.6 kHz	5.1 kHz	1.1 ms	5.6 ms	533.2 Hz
Normal	300 Hz	-	300.0 Hz	1.5 kHz	3.1 kHz	1.9 ms	9.4 ms	319.9 Hz
Normal	200 Hz	-	200.0 Hz	1.0 kHz	2.1 kHz	2.8 ms	14.1 ms	213.3 Hz
Normal	100 Hz	-	100.0 Hz	514.5 Hz	1.0 kHz	5.6 ms	28.2 ms	106.6 Hz
Normal	50 Hz	-	50.0 Hz	257.3 Hz	514.5 Hz	11.2 ms	56.4 ms	53.3 Hz
Normal	30 Hz	-	30.0 Hz	154.3 Hz	308.7 Hz	18.7 ms	93.9 ms	32.0 Hz
Normal	20 Hz	-	20.0 Hz	102.9 Hz	205.8 Hz	28.0 ms	140.9 ms	21.3 Hz
Normal	10 Hz	-	10.0 Hz	51.4 Hz	102.9 Hz	56.0 ms	272.1 ms	10.7 Hz
LTE**	5 MHz	4.0 MHz	4.5 MHz	5.0 MHz	10.0 MHz	154.4 ns	13.3 μ s	4.5 MHz
LTE**	10 MHz	8.1 MHz	9.0 MHz	9.9 MHz	20.0 MHz	77.3 ns	6.8 μ s	9.0 MHz
LTE**	15 MHz	12.2 MHz	13.5 MHz	14.9 MHz	30.0 MHz	51.9 ns	4.7 μ s	13.5 MHz
LTE**	20 MHz	16.2 MHz	18.0 MHz	19.8 MHz	30.0 MHz	39.7 ns	2.5 μ s	17.5 MHz
3GPP**	3.84 MHz	3.0 MHz	3.84 MHz	4.7 MHz	10.0 MHz	175.4 ns	13.3 μ s	3.8 MHz

* only for pulse measurements

** only available filter types for ACLR measurements; for continuous average, trace, time gate mode, all 4 filter types are available.

7.4 RF input attenuation

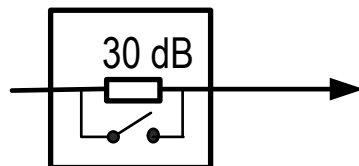

Adjust the input attenuator to prevent that mixers and amplifiers operate close to their compression points. Thus, uncertainties in the measurement result due to nonlinear effects such as intermodulation products and gain compression are decreased. However, as a side effect, the signal-to-noise ratio (SNR) is decreased. The signal-to-noise ratio is the true signal power versus the noise floor power within the relevant RBW.

Decreasing the signal-to-noise ratio causes two effects:

- The measurement uncertainty is increased due to noise.
- The measured power signal includes a bias that depends on the signal-to-noise ratio, see also [Chapter 8.1.1, "Averaging domains"](#), on page 61.

To measure the noise power for the current RBW

1. Turn off the signal source.

- Increase the average count until the measurement results are stable.

7.5 Top pane parameters

Access: main dialog of the web user interface > top pane

In the web user interface, these settings are grouped in the top pane.

Autoset.....	57
Signal Check.....	57
Frequency.....	58
Filter / Bandwidth.....	58
L <State>.....	59
L <Filter type>.....	59
L <Bandwidth>.....	59
Attenuator.....	59
L <State>.....	59
L <Level>.....	60
S-Parameter.....	60
L <State>.....	60

Autoset

Performs the automatic settings. See [Chapter 7.1, "Automatic settings"](#), on page 49.

Remote command:

```
[SENSe<Sensor>:]ADJust[:ALL]
[SENSe<Sensor>:]BANDwidth:RESolution:TYPE:AUTO[:STATe]
[SENSe<Sensor>:]INPut:ATTenuation:AUTO
INITiate:CONTinuous
```

Signal Check

Opens the "Signal Check" dialog. It displays the intermediate frequency (IF) spectrum of the test signal and the selected bandwidth. See also [Chapter 8.4, "IF spectrum preview"](#), on page 73.

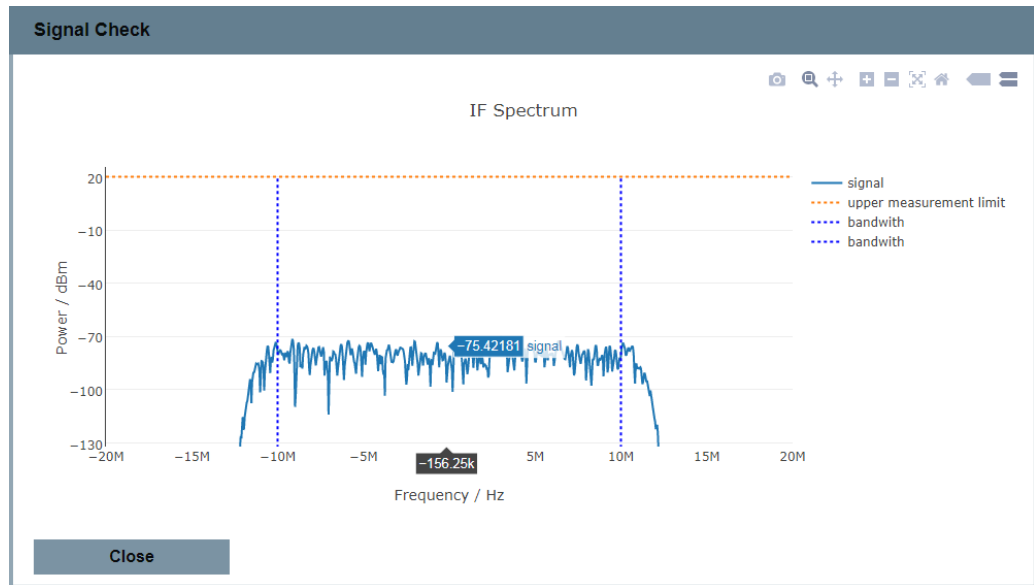

Within the chart, the cursor becomes a crosshair. The x-position (frequency) of the crosshair is shown on black background below the x-axis, the y-position (power) is shown in the color of the graph.

Remote command:

[SENSe<Sensor>:] SPECTrum:FFT:FREQuency:STARt? on page 151

[SENSe<Sensor>:] SPECTrum:FFT:FREQuency:STEP? on page 152

[SENSe<Sensor>:] SPECTrum:FFT:POINts on page 152



Frequency

Sets the carrier frequency of the applied signal. This value is used for frequency response correction of the measurement result.

Left to the frequency value, the frequency tracker status is displayed, see [Table 7-5](#).

For background information, see [Chapter 7.2, "Frequency configuration"](#), on page 50.

Table 7-5: Frequency tracker status

Color		Status
	Gray	Disabled.
	Yellow	Enabled but not locked on the frequency at the RF input.
	Green	Enabled and locked on the frequency at the RF input. Usual status after autose.

Remote command:

[SENSe<Sensor>:] FREQuency [:CENTer]

Filter / Bandwidth

For background information, see [Chapter 7.3, "Resolution bandwidth filters"](#), on page 52.

<State> ← Filter / Bandwidth

Enables or disables the automatic filter type selection.

"Manual" Select the filter under "<Filter type>" on page 59.

"Auto" The selection depends on the currently chosen measurement mode and bandwidth.

Remote command:

```
[SENSe<Sensor>:]BANDwidth:RESolution:TYPE:AUTO[:STATe]
```

<Filter type> ← Filter / Bandwidth

Only available if "Manual" is set under <State>.

Sets the filter type for resolution bandwidth filter. The filter bandwidth is not affected. See also [Chapter 7.3.1, "Filter characteristics"](#), on page 52.

"Flat" Flat frequency spectrum with steep filter edges.

"Normal" Gaussian-like filters with less than 5 % overshoot.

"LTE" Optimized for LTE signal.

"3GPP" Optimized for 3GPP signal.

Remote command:

```
[SENSe<Sensor>:]BANDwidth:RESolution:TYPE
[SENSe<Sensor>:]BANDwidth:INFO?
```

<Bandwidth> ← Filter / Bandwidth

Sets the resolution bandwidth as floating point value.

<value> in Hz, kHz or MHz. The unit is adopted.

If the resampler is disabled, only discrete steps are available. The entered value is rounded to the next value.

The filter bandwidth refers to the RBW display value in [Table 7-4](#) and its definition varies with the filter type. Each type has its own steps. See also [Chapter 7.3.3, "Choosing the correct filter type"](#), on page 54.

Remote command:

```
[SENSe<Sensor>:]BANDwidth:RESolution
[SENSe<Sensor>:]BANDwidth:RESolution:CUV?
```

Attenuator

For background information, see [Chapter 7.4, "RF input attenuation"](#), on page 56.

<State> ← Attenuator

Enables or disables the automatic setting of the input attenuation.

Note: In continuous measurement mode, the automatic attenuator feature does not work reliably, especially after sudden changes in the input power level. It can happen that the 30 dB attenuator is turned on even while measuring signals below threshold and vice versa.

Remote command:

```
[SENSe<Sensor>:]INPut:ATTenuation:AUTO
```

<Level> ← Attenuator

Only available if "Manual" is set under **<State>**.

Sets the input attenuation.

Remote command:

```
[SENSe<Sensor>:] INPut:ATTenuation
```

S-Parameter

For background information, see [Chapter 12.9.7.4, "S-parameter corrections"](#), on page 163.

<State> ← S-Parameter

Enables or disables the S-parameter corrections.

8 Measurement modes and result displays

The R&S NRQ6 offers different measurement modes.

Further information:

- [Chapter 6.1, "Functional principle"](#), on page 42
- [Chapter 6.2, "Measurement procedure in principle"](#), on page 42
- [Chapter 9, "Measurement configuration"](#), on page 82
- [Chapter 5.2.1, "Layout of the main dialog"](#), on page 35
- ["To display the Web user interface"](#) on page 35

Remote command reference:

- [Chapter 12.4, "Selecting a measurement mode"](#), on page 127
- [Chapter 12.5, "Starting and ending a measurement"](#), on page 128
- [Chapter 12.6, "Measurement results"](#), on page 129

Web user interface:

- [Chapter 8.1.3, "Continuous average parameters"](#), on page 63
- [Chapter 8.2.1, "Trace parameters"](#), on page 66
- [Chapter 8.3.1, "ACLR parameters"](#), on page 70
- [Chapter 8.5, "I/Q trace mode"](#), on page 73

In the web user interface, all measurement modes are grouped in the navigation pane under "Measurements".

8.1 Continuous average mode

In this mode, the R&S NRQ6 measures the signal average power asynchronously within a defined time interval, the so-called aperture or sampling window. After a trigger event, the power is integrated over the time interval, see [Chapter 8.1.1, "Averaging domains"](#), on page 61.

Contents:

- [Averaging domains](#)..... 61
- [Measuring modulated signals](#)..... 63
- [Continuous average parameters](#).....63
- [Continuous average result display](#).....65

8.1.1 Averaging domains

In continuous average and trace mode, the R&S NRQ6 supports three different averaging domains with the following characteristics.

Table 8-1: Averaging domains

	Power averaging	Logarithmic averaging	Amplitude averaging
Command option	"Power"	"Video"	"Linear"
Averaging unit	Watt	dBm	V
Measurement bias caused by noise floor	High	Low	Medium
Measurement uncertainty caused by noise floor	Low	High	Medium
Measurement bias for noise-like signals	0 dB	-2.51 dB	-1.05 dB
Remote command: [SENSe<Sensor>:]AVERage:TYPE on page 146			

Noise-like signals are the noise floor or digitally modulated signals with a flat spectrum, covering the complete RBW.

Measurement bias

Measurement bias means that the measurement value is biased such that the measured value is larger than the true value. When measuring the power of a continuous wave (CW) signal in the presence of noise, the measured power is simply the algebraic sum of the signal and noise powers. When measuring the voltage or logarithmic power of a CW signal in the presence of noise, the calculation of the measurement bias is considerably more complex. For example, for a signal-to-noise ratio of 8 dB, logarithmic averaging results in a measurement bias due to noise of approximately 0.001 dB. For further information, the following article is recommended: NCSLI Measure: The Journal of Measurement Science, December 2012, "Spectrum Analyzer CW Power Measurements and the Effects of Noise".

Measurement noise

The measurement noise quantifies the amount of fluctuation that is to be expected in the measurement result. The measurement uncertainty can be decreased by time averaging. For large signal-to-noise ratios (SNR), the amount of measurement noise is independent of the averaging method. For small signal-to-noise ratios, the amount of measurement noise depends on the averaging method as described in [Table 8-1](#).

Taking the signal type into account

Due to the different behavior described in [Table 8-1](#), select the averaging domain in consideration of the signal type.

Signal type	"Averaging Domain"	Explanation
Continuous wave (CW)	"Video"	No noticeable measurement bias for a signal-to-noise ratio equal to and above 8 dB. Increase in measurement uncertainty is negligible. Can be combined with noise cancellation.
Noise power	"Power"	No measurement bias even if there is colored noise spectrum. Be sure to disable noise cancellation feature.
Broadband communication signal and all other signals	"Power"	No measurement bias due to signal form. Measurement bias due to noise floor can be reduced by noise cancellation feature.

8.1.2 Measuring modulated signals

When measuring modulated signals, the measurement can show fluctuation due to the modulation. If that is the case, adapt the size of the sampling window exactly to the modulation period to get an optimally stable display.

If measuring pulse-modulated signals, use the duty cycle correction. The duty cycle correction is only available in the continuous average mode. The duty cycle defines the percentage of one period during which the signal is active.

8.1.3 Continuous average parameters

Access: main dialog of the web user interface > navigation pane > "Continuous Average"



- Autoset..... 64
- Trigger Mode..... 64
- Trigger Level..... 64
- Trigger Source..... 64
- Trigger Delay..... 64
- Averaging Count..... 64
 - <State>..... 64
 - <Count>..... 64
- Averaging Domain..... 64

Moving Average.....	65
Aperture Time.....	65
Duty Cycle.....	65

Autoset

Starts a continuous measurement.

Remote command:

TRIGger:SOURce IMMEDIATE

INITiate:CONTinuous ON

Trigger Mode

See "Trigger Mode" on page 91.

Trigger Level

See "Trigger Level" on page 92.

Trigger Source

See "Trigger Source" on page 92.

Trigger Delay

See "Trigger Delay" on page 92.

Averaging Count

Groups the averaging count settings. Average count is often also called averaging factor.

<State> ← Averaging Count

Enables or disables the averaging filter.

Remote command:

[SENSe<Sensor>:] AVERAge [: STATE]

<Count> ← Averaging Count

Available if "On" is set under <State>.

Sets the number of readings that are averaged for one measured value. The higher the count, the lower the noise, and the longer it takes to obtain a measured value.

Remote command:

[SENSe<Sensor>:] AVERAge: COUNT

Averaging Domain

Sets the averaging method. For details, see [Chapter 8.1.1, "Averaging domains"](#), on page 61.

"Power" Power averaging

"Video" Logarithmic averaging

"Linear" Voltage averaging

Remote command:

[SENSe<Sensor>:] AVERAge: TYPE

Moving Average

Defines how the measurement results are output, also called termination control. See also [Chapter 9.1.1, "Controlling the measurement results"](#), on page 82.

- "On" Outputs intermediate values to facilitate early detection of changes in the measured quantity. In the settled state, that means when the number of measurements specified by the average count has been performed, a moving average is output.
- "Off" Specifies that a measurement result is not output until the entire measurement has been completed. Meaning that the number of measurement cycle repetitions is equal to the set average count. If the average count is large, the measurement time can be long.

Remote command:

```
[SENSe<Sensor>:]AVERAge:TCONtrol
```

Aperture Time

Sets the duration of the sampling window. During this unsynchronized time interval, the average signal power is measured.

Remote command:

```
[SENSe<Sensor>:] [POWer:] [AVG:]APERTure
```

Duty Cycle

Sets the duty cycle for measuring pulse-modulated signals. The duty cycle defines the percentage of one period during which the signal is active. If the duty cycle is enabled, the R&S NRQ6 considers this percentage when calculating the signal pulse power from the average power.

Remote command:

```
[SENSe<Sensor>:]CORRection:DCYCLe:STATe
[SENSe<Sensor>:]CORRection:DCYCLe
```

8.1.4 Continuous average result display

Displays a single scalar value.

**8.1.4.1 Configuring the continuous average result display**

dBm / Watt / dB μ V.....	65
Average / Peak / Random.....	66

dBm / Watt / dB μ V

Sets the unit of the measured power values (y-axis of the chart).

Remote command:
[UNIT:POWer](#) on page 138

Average / Peak / Random

Selects the measurand for which the last valid measurement result is displayed.

- "Average" or "Random": average value
- "Peak": peak value

Remote command:
[CALCulate:FEED](#) on page 130

8.2 Trace mode

In this mode, the R&S NRQ6 measures power over time. The number of measurement points and the measurement time is defined. The length of an individual measurement is determined from the ratio of total time and the defined number of measurement points. The entire result is called a "trace". Each trace must be triggered separately.

For information on averaging, see [Chapter 8.1.1, "Averaging domains"](#), on page 61.

Contents:

- [Trace parameters](#)..... 66
- [Trace result display](#)..... 68

8.2.1 Trace parameters

Access: main dialog of the web user interface > navigation pane > "Trace"

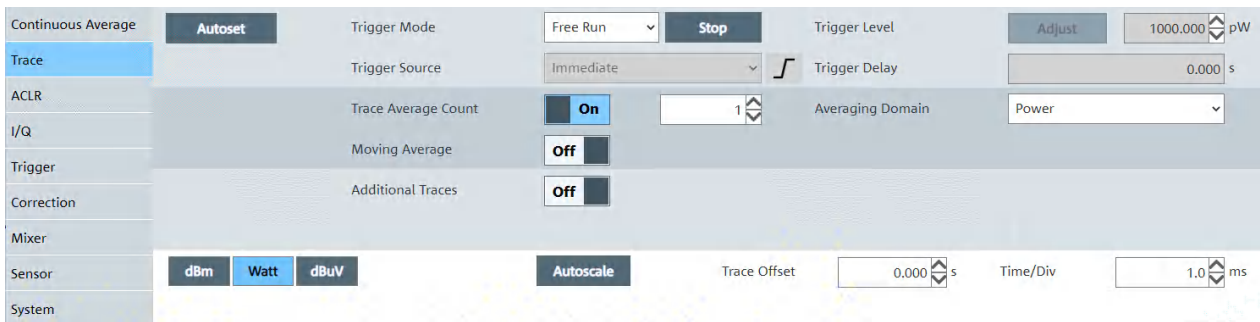

- [Autoset](#)..... 67
- [Trigger Mode](#)..... 67
- [Trigger Level](#)..... 67
- [Trigger Source](#)..... 67
- [Trigger Delay](#)..... 67
- [Trace Averaging Count](#)..... 67
 - ↳ [<State>](#)..... 67
 - ↳ [<Count>](#)..... 67

Averaging Domain	67
Moving Averaging	68
Additional Traces	68

Autoset

Adjusts the following:

- Adjusts the trace settings to the current signal.
- Optimizes the scaling of the x- and y-axes.
- Sets the trigger to ensure a stable presentation of the test signals.

Remote command:

```
TRIGger:LEVel:AUTO ONCE
[SENSe<Sensor>:] TRACe:TIME:AUTO ONCE
TRIGger:ATRigger[:STATe] ON
TRIGger:SOURce INTernal
[SENSe<Sensor>:] TRACe:AVERAge:COUNT 1
```

Trigger Mode

See "[Trigger Mode](#)" on page 91.

Trigger Level

See "[Trigger Level](#)" on page 92.

Trigger Source

See "[Trigger Source](#)" on page 92.

Trigger Delay

See "[Trigger Delay](#)" on page 92.

Trace Averaging Count

Groups the averaging count settings. Average count is often also called averaging factor.

<State> ← Trace Averaging Count

Enables or disables the averaging filter.

Remote command:

```
[SENSe<Sensor>:] TRACe:AVERAge[:STATe]
```

<Count> ← Trace Averaging Count

Available if "On" is set under [<State>](#).

Sets the number of readings that are averaged for one measured value. The higher the count, the lower the noise, and the longer it takes to obtain a measured value.

Remote command:

```
[SENSe<Sensor>:] TRACe:AVERAge:COUNT
```

Averaging Domain

See "[Averaging Domain](#)" on page 64.

Moving Averaging

See ["Moving Average"](#) on page 65.

Remote command:

```
[SENSe<Sensor>:] TRACe:AVERage:TCONtrol
```

Additional Traces

Enables or disables the display of additional traces. The additional traces show the measurement results of the auxiliary measurands, peak and random.

- "Off" The trace result display shows the measurement sequence (average).
- "On" The trace result display shows the measurement results of the measurands selected by [Average / Peak / Random](#).

8.2.2 Trace result display

Displays a trace consisting of an array of scalar values.

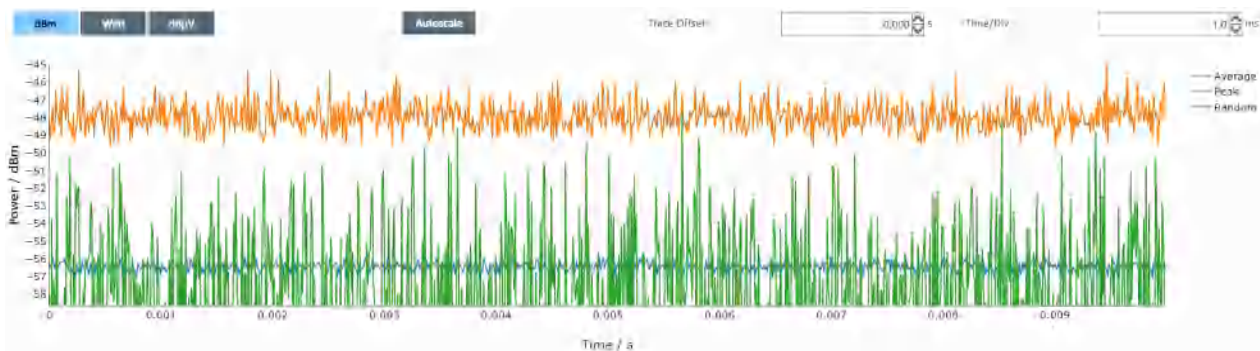
**To read positions**

- Place the cursor within the chart.

The cursor becomes a crosshair. The y-position (1, power) is shown next to the trace, the x-position (2, time) is shown below the x-axis.



To move the plot

Use the mouse to move the plot in x- and y-direction.

1. Place the mouse over the x-axis.
2. With the left mouse button pressed, drag the x-axis to the right or left.

The same works for the y-axis in vertical direction.

To analyze the chart in detail

- ▶ Use the toolbar in the upper right corner of the chart. See [Chapter 5.2.3, "Toolbar in charts"](#), on page 37.

8.2.2.1 Configuring the trace result display

Autoscale	69
dBm / Watt / dBμV	69
Trace Offset	69
Time/Div	69
Average / Peak / Random	69

Autoscale

Optimizes the y-axis scaling.

dBm / Watt / dB μ V

See "[dBm / Watt / dB \$\mu\$ V](#)" on page 65.

Trace Offset

Sets the relative position of the trigger event in relation to the trace measurement start:

Trace offset = trace measurement start - trigger delay.

The start of recording relative to the trigger event is set using [Trigger Delay](#).

Remote command:

```
[SENSe<Sensor>:] TRACe:OFFSet:TIME
```

Time/Div

Sets the trace time, the duration of one trace sequence. If you enter the numbers followed by one of the letters, you can change the dimension; s for second, m for ms, n for ns, u for μ s.

The available range depends on the RBW. Even for time settings within range, a static error due to insufficient memory can occur if the output sampling rate is too high. See [Chapter 7.3.3, "Choosing the correct filter type"](#), on page 54.

Remote command:

```
[SENSe<Sensor>:] TRACe:TIME
```

Average / Peak / Random

If [Additional Traces](#) are enabled, shows or hides the last valid measurement result of the selected measurands. Multiple selection is possible.

- "Average":

- Measurement sequence
- "Peak":
Peak value of the samples per trace point, available in trace mode if the number of measured values is sufficient. See "Requirements in trace mode" on page 130.
 - "Random":
Randomly selected value of the samples per trace point, available in trace mode if the number of measured values is sufficient. See "Requirements in trace mode" on page 130.

Remote command:
CALCulate:FEED on page 130

8.3 ACLR mode

In this mode, the adjacent channel leakage ratio (ACLR) is displayed. The ACLR is measured by an FFT analysis of a signal wide enough to contain all 5 channels.

4 predefined filters for 3GPP and LTE are available. The set bandwidth defines the filter, see Table 7-4. Only one of the filters is set at a time.

The R&S NRP Toolkit provides program examples on this topic.

Further details:

- Chapter 5.1, "R&S NRP Toolkit", on page 32
- Chapter 13, "Programming examples", on page 192

Contents:

- ACLR parameters.....70
- ACLR result display.....71
- DC zeroing in ACLR mode.....72

8.3.1 ACLR parameters

Access: main dialog of the web user interface > navigation pane > "ACLR"

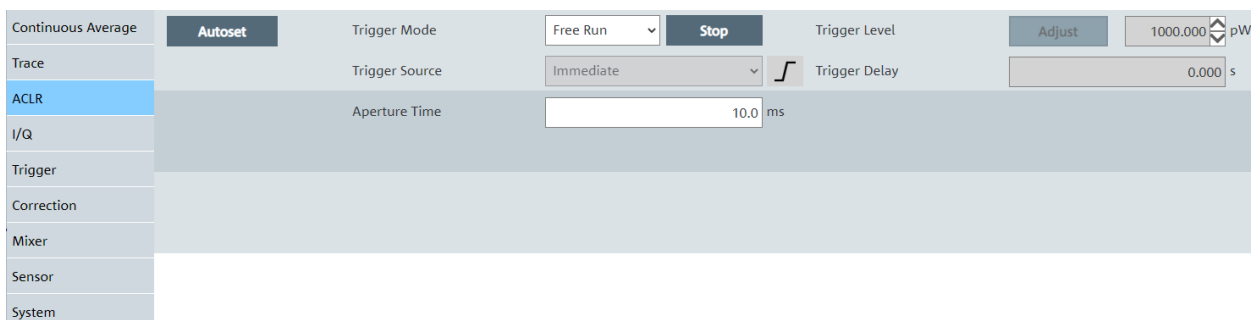

- Autoset.....71
- Trigger Mode.....71
- Trigger Level.....71

Trigger Source.....	71
Trigger Delay.....	71
Aperture Time.....	71

Autoset

Starts a continuous measurement.

Remote command:

`TRIGger:SOURce IMMEDIATE`

`INITiate:CONTinuous ON`

Trigger Mode

See "[Trigger Mode](#)" on page 91.

Trigger Level

See "[Trigger Level](#)" on page 92.

Trigger Source

See "[Trigger Source](#)" on page 92.

Trigger Delay

Negative trigger delays are not supported.

See "[Trigger Delay](#)" on page 92.

Aperture Time

Sets the duration of the sampling window. During this synchronized time interval, the average signal power is measured on all 5 channels.

Remote command:

`[SENSe<Sensor>:]ACLR:APERture`

8.3.2 ACLR result display

Displays an array of scalar values.

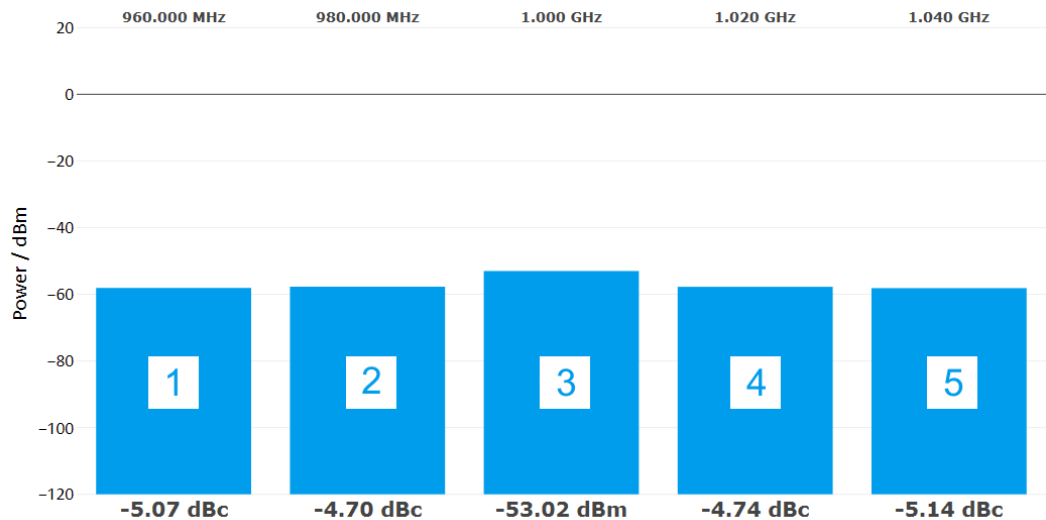



Figure 8-1: Example for LTE

- 1 = Lower alternate channel
- 2 = Lower adjacent channel
- 3 = TX channel
- 4 = Upper adjacent channel
- 5 = Upper alternate channel

To download the chart

- ▶ Click  in the upper right corner of the chart. See [Chapter 5.2.3, "Toolbar in charts"](#), on page 37.

Further information

An application sheet describes how to perform ACLR measurements on LTE advanced/5G signals with a bandwidth of 100 MHz. It has the title "ACLR 100 MHz (Using FFT Filtering)" and is available at:

www.rohde-schwarz.com/manual/NRQ6

8.3.3 DC zeroing in ACLR mode

If you use the LTE filter with 10 MHz, 15 MHz or 20 MHz resolution bandwidth, a DC offset can occur. For example with 20 MHz ACLR bandwidth, the R&S NRQ6 measures internally with a total bandwidth of 100 MHz. If you measure signals of low power, the TX channel shows a DC offset. You can correct this offset using the DC offset calibration.

1. Change to another measurement mode, for example the continuous average mode.
2. Set a resolution bandwidth larger than 40 MHz, for example 100 MHz.
3. Perform DC zeroing, see ["To calibrate the DC offset"](#) on page 98.

4. Change back to the pulse analysis mode.

Further information:

- [Chapter 9.3.2.2, "DC zeroing"](#), on page 98

8.4 IF spectrum preview

The intermediate frequency (IF) spectrum gives a quick preview of the test signal. You can check the test signal itself and whether the selected bandwidth fits your purpose, but the resolution in this preview is limited.

In the web user interface, the preview is available as ["Signal Check"](#) on page 57.

In remote control, the preview is implemented as an extra measurement mode that you can configure. You can define the number of FFT points and the start frequency. The frequency range is determined from the frequency increment between FFT points and the total number of FFT points.

Further details:

- [Chapter 12.4, "Selecting a measurement mode"](#), on page 127
- [Chapter 12.6.5, "Retrieving IF spectrum results"](#), on page 136
- [Chapter 12.9.4, "Configuring an IF spectrum"](#), on page 151



For signal analysis in high resolution, the R&S NRQ6 provides the I/Q trace mode, see [Chapter 8.5, "I/Q trace mode"](#), on page 73.

8.5 I/Q trace mode

Requires the I/Q data interface (R&S NRQ6-K1). For information on the option management, see [Chapter 10.1, "Option management"](#), on page 107.

In this mode, triggering works as in trace mode. Negative trigger delays are not supported.

You can read out the I/Q data for external signal analysis, for example using the vector signal explorer software (R&S VSE) from Rohde & Schwarz. An application sheet describes the use of the R&S NRQ6 as an I/Q data source for the software R&S VSE vector signal explorer. It has the title "VSE Feed (I/Q Capturing)" and is available at:

www.rohde-schwarz.com/manual/NRQ6

The R&S NRP Toolkit provides program examples on this topic.

Further details:

- [Chapter 5.1, "R&S NRP Toolkit"](#), on page 32
- [Chapter 13, "Programming examples"](#), on page 192

8.5.1 Phase coherent measurements

Requires the phase coherent measurements option (R&S NRQ6-K3). For information on the option management, see [Chapter 10.1, "Option management"](#), on page 107.

Using two R&S NRQ6, you can measure phase coherence in a multitone analysis. By measuring the relative phase error between calibration port and each antenna port, you can calibrate active antenna modules for beamforming.

For this purpose, two separate measurement steps are performed:

- Calibration
- Measurement

Setup for calibration

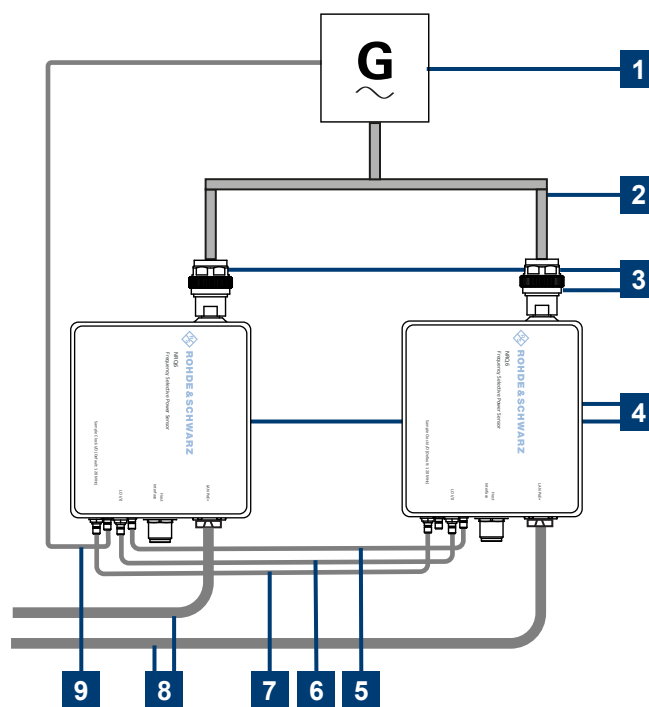

Figure 8-2: Calibrating the system

- 1 = Signal generator (signal source)
- 2 = External reference fed into the reference clock of the sender R&S NRQ6
- 3 = Power splitter
- 4 = RF connector
- 5 = R&S NRQ6
- 6 = Sampling clock connection
- 7 = Local oscillator connection
- 8 = Trigger connection
- 9 = LAN connection to controlling host and power supply, see [Chapter 3.6.1, "Computer using a LAN connection"](#), on page 17.

To calibrate the system accurately, proceed as follows:

1. Use a splitter that is highly symmetrical in the frequency band of interest.

2. Connect the reference output of the signal generator and the reference input of the R&S NRQ6 using a standard coaxial cable.
3. Connect the two R&S NRQ6 using standard SMA cables. Ensure that the cables used for the trigger and sample clock connection are of identical length to ensure a proper eye diagram.
 - a) Trigger connection: TRIG2 -> TRIG2
 - b) Sampling clock connection: CLK -> CLK
 - c) Local oscillator connection: LO -> LO

See also [Figure 4-1](#).

Configuration for calibration

1. Enable the use of an external reference clock for the R&S NRQ6, to which the external reference is fed.
2. Establish a sender/receiver relationship for triggering:
 - a) Configure the R&S NRQ6 that is fed the external reference as sender.
 - b) Configure the other R&S NRQ6 as receiver.
3. Select the trigger sources for both R&S NRQ6.
4. Configure the two R&S NRQ6 so that the sender R&S NRQ6 forwards its sampling clock signal and local oscillator signal to the receiver R&S NRQ6.

Main calibration steps

1. Measure the phase difference between the two R&S NRQ6.
2. Save the calibration data.

Setup for measurement

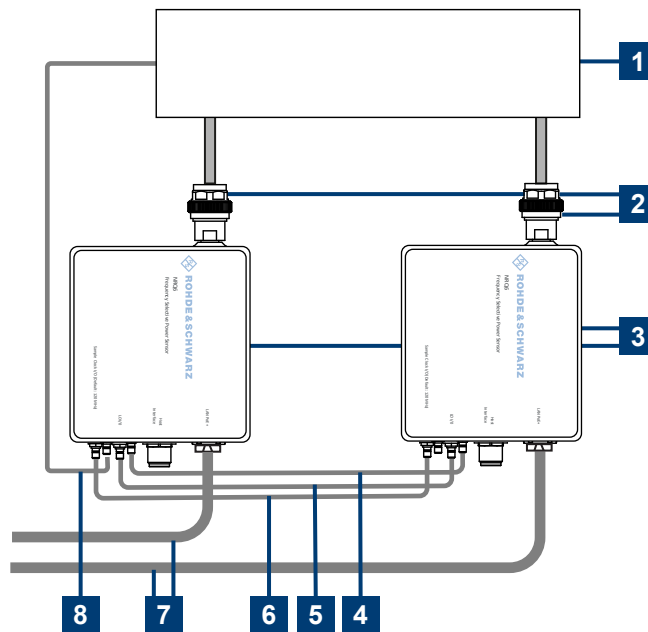

Figure 8-3: Measuring the phase difference

- 1 = 2-port DUT (signal source)
- 2 = External reference fed into the reference clock of the sender R&S NRQ6.
- 3 = RF connector
- 4 = R&S NRQ6
- 5 = Sampling clock connection
- 6 = Local oscillator connection
- 7 = Trigger connection
- 8 = LAN connection to controlling host and power supply, see [Chapter 3.6.1, "Computer using a LAN connection"](#), on page 17.

1. Connect the RF port of each R&S NRQ6 to a DUT port.
2. Connect the two R&S NRQ6 as described in [step 3](#).

Configuration for measurement

- Perform the steps as described in ["Configuration for calibration"](#) on page 75.

Main measurement steps

1. Measure the phase difference between the two ports of the DUT.
2. Use the calibration data to eliminate the phase difference caused by the R&S NRQ6 and to obtain the relative phase difference between the DUT ports.

An application sheet describes the calibration of active antenna modules for beam-forming. It has the title "Phase Coherent Measurements" and is available at:

www.rohde-schwarz.com/manual/NRQ6

A video shows measuring the relative phase difference between two RF signals. It is available at:

<https://www.rohde-schwarz.com/product/nrq6>

The R&S NRP Toolkit provides program examples on this topic.

Further details:

- [Chapter 5.1, "R&S NRP Toolkit"](#), on page 32
- [Chapter 13, "Programming examples"](#), on page 192

In the web user interface, the option-specific parameters are integrated.

8.5.2 Setting the sample rate

There are two ways to adjust the sample rate.

To set the sample rate directly

1. Under [Specify Bandwidth by](#), set "Sample Rate".
2. Enter the sample rate in [Desired Sample Rate](#).
The [Used Sample Rate](#) is set accordingly to the closest discrete sample rate.
3. If you want to set exactly the desired sample rate, enable [Variable Bandwidth](#). Works properly only up to 40 MHz sample rate.
[Desired Sample Rate](#) and [Used Sample Rate](#) are identical.

To set the sample rate indirectly

1. Under [Specify Bandwidth by](#), set "Resolution Bandwidth".
2. Under [Filter / Bandwidth](#), enter the bandwidth.
The [Used Sample Rate](#) is set accordingly.
The value in [Desired Sample Rate](#) is inconsequential.

8.5.3 I/Q trace parameters

Requires the I/Q data interface (R&S NRQ6-K1). If a parameter requires an additional option, the option is listed in the parameter description.

Access: main dialog of the web user interface > navigation pane > "I/Q"

Continuous Average	Autoset	Trigger Mode	Free Run	Stop	Trigger Level	Adjust	1000.000	pW
Trace		Trigger Source	Immediate		Trigger Delay		0.000	s
ACLR		Result Length						
I/Q		Specify Bandwidth by	Resolution Bandwidth		Variable Bandwidth	off		
Trigger		Desired Sample Rate			Used Sample Rate		4000000	
Correction		Sync Mode	Off		Captured I/Q Samples	Download		
Mixer								
Sensor								
System								

Autoset.....	78
Trigger Mode.....	78
Trigger Level.....	78
Trigger Source.....	78
Trigger Delay.....	78
Result Length.....	78
Specify Bandwidth by.....	79
Variable Bandwidth.....	79
Desired Sample Rate.....	79
Used Sample Rate.....	79
Sync Mode.....	79
Captured I/Q Samples.....	80

Autoset

Adjusts the trace settings to the current signal.

Remote command:

```
TRIGger:LEVel:AUTO ONCE
[SENSe<Sensor>:] TRACe:TIME:AUTO ONCE
TRIGger:ATRigger[:STATe] ON
TRIGger:SOURce INTernal
[SENSe<Sensor>:] TRACe:AVERage:COUNT 1
```

Trigger Mode

See "[Trigger Mode](#)" on page 91.

Trigger Level

See "[Trigger Level](#)" on page 92.

Trigger Source

See "[Trigger Source](#)" on page 92.

Trigger Delay

See "[Trigger Delay](#)" on page 92.

Result Length

Sets the number of result samples.

Remote command:

```
[SENSe<Sensor>:] TRACe:IQ:RLENgth
```

Specify Bandwidth by

Sets how the bandwidth is specified.

"Resolution Bandwidth" By the resolution bandwidth.

"Sample Rate" By the sample rate.

Remote command:

```
[SENSe<Sensor>:]BANDwidth:TYPE
```

Variable Bandwidth

Enables the resampler or continuous adjustment. Affects either the sample rate or the resolution bandwidth, depending on the setting under [Specify Bandwidth by](#).

"Off" Selected sample rate or resolution bandwidth is rounded to a discrete value.

"On" Exact value is used up to:

- $RBW \leq 20$ MHz with flat filter type
- $RBW \leq 5$ MHz with normal filter type
- Sample rate ≤ 40 MHz

If an exact value is set that is out of range, the R&S NRQ6 indicates a static error. See also [Chapter 4.2, "Status information"](#), on page 28.

Remote command:

```
[SENSe<Sensor>:]BANDwidth:VARiable on page 126
```

Desired Sample Rate

Effective if "Sample Rate" is set under [Specify Bandwidth by](#).

Sets the desired value for the sample rate input. See [Chapter 8.5.2, "Setting the sample rate"](#), on page 77.

Remote command:

```
[SENSe<Sensor>:]BANDwidth:SRATe
```

Used Sample Rate

Displays the currently used sample rate. See [Chapter 8.5.2, "Setting the sample rate"](#), on page 77.

Remote command:

```
[SENSe<Sensor>:]BANDwidth:SRATe:CUV?
```

Sync Mode

Requires the phase coherent measurements option (R&S NRQ6-K3).

Sets the synchronization for phase coherent measurements.

- "Off" No synchronization
- "Sender" Is synchronized to the signal source by external reference and triggers the receiver. Select the output port for the trigger signal under [Sender Port](#).
- "Receiver" Is triggered by the sender.

See also [Chapter 9.2.6, "Trigger sender usage"](#), on page 90.

Remote command:

```
[SENSe<Sensor>:] TRACe:IQ:SYNC:TYPE
```

Captured I/Q Samples

Available if "Free Run" is set under [Trigger Mode](#).

Click "Download" to export the I/Q sample values in an *.iq.tar file. This file is suited for import into the vector signal explorer software, R&S VSE, from Rohde & Schwarz. From version 01.70, the R&S VSE software provides full integration.

Note: The "Download" button is available if [Result Length](#) ≤ 262000. For a larger result length, use remote control.

If you are using the R&S VSE software for analysis and it does not work, check whether the [Result Length](#) is large enough.

I/Q samples are scaled voltage values that give amplitude and phase information in a Cartesian coordinate system. I/Q data shows the changes in magnitude (or amplitude) and phase of a sine wave.

For more information, visit us at:

- [R&S VSE software](#)
- [Rohde & Schwarz iq-tar File Format Specification](#)

Remote command:

```
[SENSe<Sensor>:] TRACe:IQ:DATA:FORMat
FORMat[:DATA]
INITiate[:IMMediate]
[SENSe<Sensor>:] TRACe:IQ:DATA?
```

8.6 Power servoing

Requires the power servoing option (R&S NRQ6-K2). For information on the option management, see [Chapter 10.1, "Option management"](#), on page 107.

For component tests, measurements are performed at a specified DUT output level. Before starting a test, you need to set the DUT output power to a specific value.

Because of nonlinearities and temperature effects, the gain of the DUT at the desired operating point can be unknown and needs to be determined iteratively. The traditional approach is to implement a control loop that runs on a computer and to use SCPI commands for querying a power sensor. This procedure can take several 10 ms, which is a long time for automated test applications.

A R&S NRQ6 fitted with the power servoing option, combined with an R&S SGT100A signal generator, offers a much faster solution. The R&S NRQ6 measures continuously and sends the results to the signal generator, using a serial interface. The regulator logic is integrated in the signal generator itself.

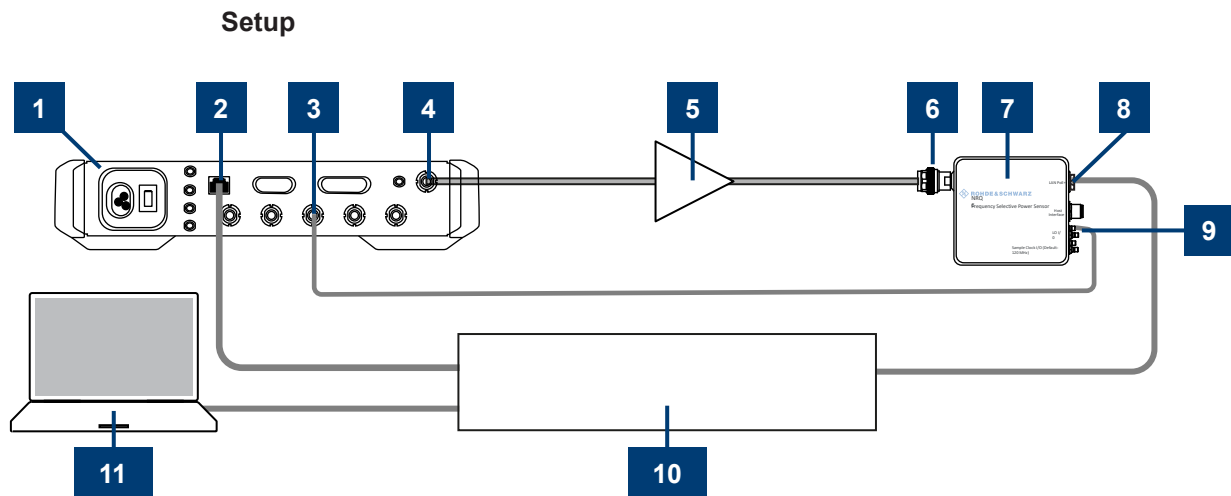

Figure 8-4: Cabling

- 1 = R&S SGT100A
- 2 = LAN interface
- 3 = USER 2 connector
- 4 = RF 50 Ω connector
- 5 = DUT
- 6 = RF connector
- 7 = R&S NRQ6
- 8 = LAN PoE+ interface
- 9 = TRIG2 connector
- 10 = Ethernet switch supporting PoE+ power delivery, for example. Alternatively, you can use the other set-ups described in [Chapter 3.6.1, "Computer using a LAN connection"](#), on page 17.
- 11 = Computer

1. Connect the instruments as shown in [Figure 8-4](#).
2. Make sure to connect the TRIG2 connector of the R&S NRQ6 to the USER 2 connector of the R&S SGT100A.
3. Connect all instruments and the computer to the local network.

An application sheet with the title "Power servoing" provides information on the measurement and application examples. The application sheet is available at:

www.rohde-schwarz.com/manual/NRQ6

Remote commands

```
[SENSe<Sensor>:]FUNCTION
```

```
SYSTem:COMMunicate:PSERvoing:BCLock
```

```
SYSTem:COMMunicate:PSERvoing:TPATtern
```

9 Measurement configuration

This chapter describes further settings for measurement configuration. Frequently used settings or settings that are only available in one measurement mode are described with the measurement mode.

Further information:

- [Chapter 8, "Measurement modes and result displays"](#), on page 61
- [Chapter 10, "System configuration"](#), on page 107

Remote command reference:

- [Chapter 12.9, "Configuring measurement settings"](#), on page 144

Web user interface:

- [Chapter 9.2.7, "Trigger parameters"](#), on page 91
- [Chapter 9.3.3, "Correction parameters"](#), on page 99
- [Chapter 9.4, "Mixer settings"](#), on page 101
- [Chapter 9.5.2, "Sensor parameters"](#), on page 105

In the web user interface, these settings are grouped in the navigation under "Settings".

9.1 Controlling the measurement

The power sensor offers a bunch of possibilities to control the measurement:

- Do you want to start the measurement immediately after the initiate command or do you want to wait for a trigger event?
- Do you want to start a single measurement cycle or a sequence of measurement cycles?
- Do you want to output each new average value as a measurement result or do you want to bundle more measured values into one result?

Further information:

- [Chapter 12.5, "Starting and ending a measurement"](#), on page 128
- [Chapter 9.2, "Trigger settings"](#), on page 88

9.1.1 Controlling the measurement results

The R&S NRQ6 can cope with the wide range of measurement scenarios with the help of the so-called "termination control". Depending on how fast your measurement results change, you can define, how the measurement results are output.

In continuous average mode, use `[SENSe<Sensor>:]AVERAge:TCOnTrol`.

In trace mode, use `[SENSe<Sensor>:]TRACe:AVERAge:TCOnTrol`.

Repeating termination control

Outputs a measurement result when the entire measurement has been completed. This means that the number of measurement cycle repetitions is equal to the set average count. If the average count is large, the measurement time can be very long.

Useful if you expect slow changes in the results, and you want to avoid outputting redundant data.

Moving termination control

Outputs intermediate values to facilitate early detection of changes in the measured quantity. This means that for each partial measurement, a new average value is output as a measurement result. Thus, the measurement result is a moving average of the last partial measurements. How many of the partial measurements are averaged is defined by the average count.

Useful if you want to detect trends in the result during the measurement.

9.1.2 Interplay of the controlling mechanisms

In the following examples, continuous measurement scenarios are used. But these scenarios apply also to single measurements. The only difference is that a single measurement is not repeated.

9.1.2.1 Continuous average mode

General settings for these examples:

- `INITiate:CONTinuous ON`
- `[SENSe<Sensor>:]AVERage:COUNT 4`

Example: Repeating termination control

Further settings for this example:

- `[SENSe<Sensor>:]TRACe:AVERage:TCONtrol REPeat`
- `[SENSe<Sensor>:]AVERage:COUNT 4`

The measurement is started by the trigger event. One measurement lasts as long as the defined aperture time. As defined by the average count, after 4 measurements, the result is averaged and available. During the whole measurement cycle, the trigger synchronization is high (`TRIGger:SYNC:STATe ON`).

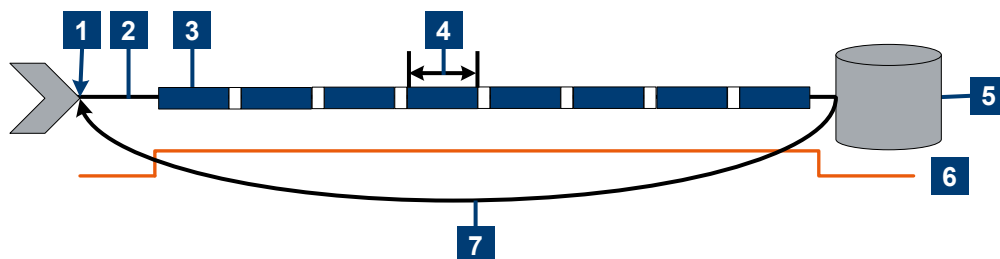

- 1 = Start of the measurement cycle
- 2 = Trigger event (only if `TRIGger:SOURce` ≠ IMMEDIATE)
- 3 = One measurement
- 4 = Duration of one aperture time
- 5 = Measurement result
- 6 = Trigger synchronization
- 7 = Return to the start of the measurement cycle

Example: Moving termination control

Further settings for this example:

- `[SENSe<Sensor>:]AVERAge:TCONTRol MOVing`
- `[SENSe<Sensor>:]AVERAge:COUNT 4`
- `TRIGger:COUNT 16`

Every measurement is started by a trigger event. One measurement lasts as long as the defined aperture time. During each measurement, the trigger synchronization is high (`TRIGger:SYNC:STATe ON`). Every measurement provides a result. During the settling phase, the amount of the result is already correct, but the noise is higher. After 4 measurements, when the average count is reached, settled data are available.

When the trigger count is reached (`TRIGger:COUNT`), the R&S NRQ6 returns to the idle state.

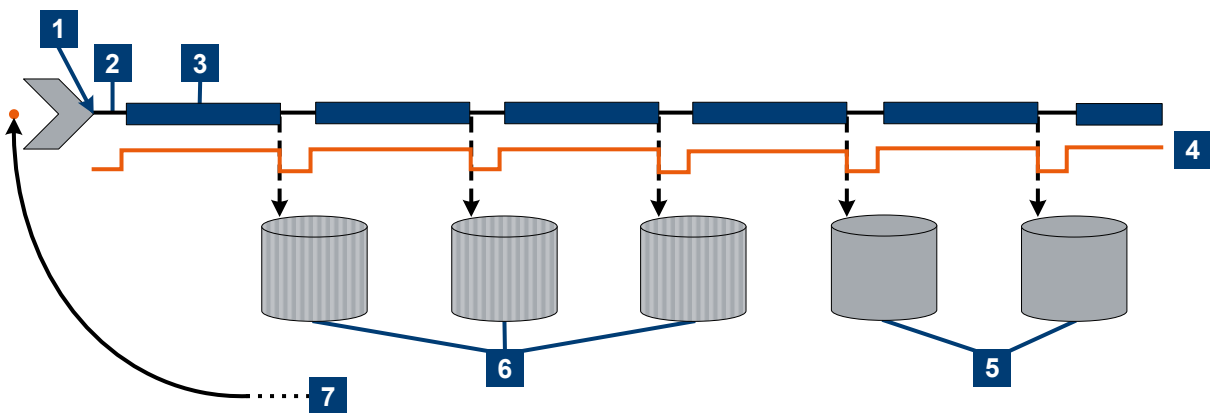

- 1 = Start of the measurement cycle
- 2 = Trigger events (only if `TRIGger:SOURce ≠ IMMEDIATE`)
- 3 = One measurement
- 4 = Trigger synchronization
- 6 = Averaged measurement result after average count is reached
- 5 = Measurement result before average count is reached
- 7 = Return to idle state after trigger count (= 16 in this example) is reached

9.1.2.2 Trace mode

General settings for the first two examples:

- `INITiate:CONTInuous ON`
- `[SENSe<Sensor>:]AVERAge:COUNT 4`

Example: Repeating termination control

Further settings for this example:

- `[SENSe<Sensor>:]AVERage:TCONTRol REPeat`

Every measurement is started by a trigger event and lasts the defined aperture time. During a measurement, the trigger synchronization is high (`TRIGger:SYNC:STATE ON`). As defined by the average count, after 4 measurements, the result is averaged and available.

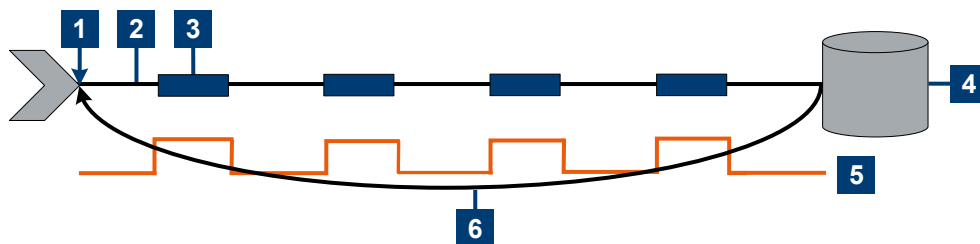

1 = Start of the measurement cycle

2 = Trigger event (only if `TRIGger:SOURce` ≠ `IMMEDIATE`)

3 = One measurement

4 = Measurement result

5 = Trigger synchronization

6 = Return to the start of the measurement cycle

Example: Moving termination control

Further settings for this example:

- `[SENSe<Sensor>:]AVERage:TCONtrol MOVing`
- `[SENSe<Sensor>:]AVERage:COUNT 4`

Every measurement is started by a trigger event and lasts the defined aperture time. During a measurement, the trigger synchronization is high (`TRIGger:SYNC:STATE ON`). Every measurement provides a result. After 4 measurements, when the average count is reached, settled data are available.

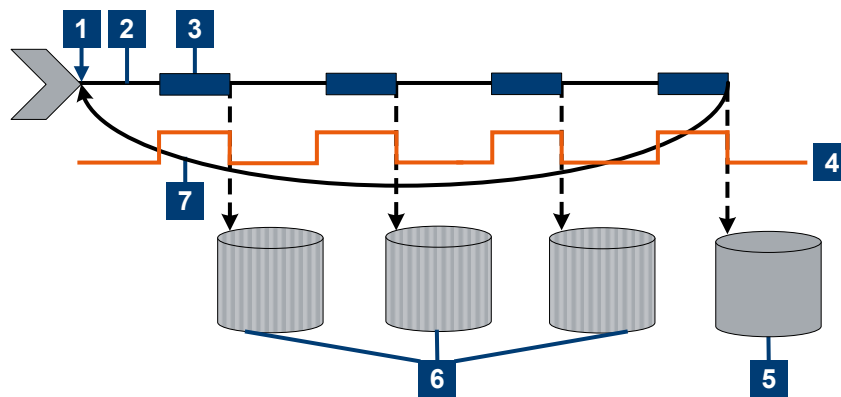

- 1 = Start of the measurement cycle
- 2 = Trigger event (only if `TRIGger:SOURce` ≠ IMMEDIATE)
- 3 = One measurement
- 4 = Trigger synchronization
- 5 = Measurement result before average count is reached
- 6 = Averaged measurement result after average count is reached
- 7 = Return to the start of the measurement cycle

Example: Average count = 1

`[SENSe<Sensor>:]AVERage:COUNT 1`

For average count 1, the setting of the termination control has no impact. In both cases, the measurement runs for the duration of one aperture time. Then, settled data are available, and the R&S NRQ6 returns to the idle state.

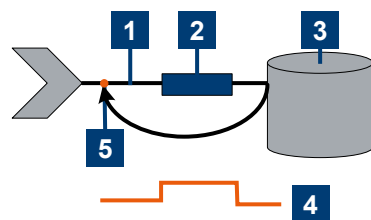

- 1 = Trigger event (only if `TRIGger:SOURce` ≠ IMMEDIATE)
- 2 = One measurement
- 3 = Measurement result
- 4 = Trigger synchronization
- 5 = Return to idle state

9.2 Trigger settings

Remote command reference:

- [Chapter 12.9.6, "Configuring the trigger"](#), on page 153

Contents:

• Trigger states	88
• Trigger sources	88
• Dropout time	89
• Hold-off time	90
• Trigger jitter	90
• Trigger sender usage	90
• Trigger parameters	91

9.2.1 Trigger states

The power sensor has trigger states to define the exact start and stop time of a measurement and the sequence of a measurement cycle. The following states are defined:

- **Idle**
The power sensor performs no measurement. After powered on, the power sensor is in the idle state.
- **Waiting for trigger**
The power sensor waits for a trigger event that is defined by the trigger source. When the trigger event occurs, the power sensor enters the measuring state.
- **Measuring**
The power sensor is measuring data. It remains in this state during the measurement. When the measurement is completed, it exits this state immediately.

9.2.2 Trigger sources

The possible trigger conditions and the execution of a trigger depend on the selected trigger mode and trigger source.

If the signal power exceeds or falls below a reference level set by the trigger level, the measurement is started after the defined delay time. Waiting for a trigger event can be skipped.

Trigger source	Description	Remote commands to initiate the measurement
"Hold"	Remains in wait state for trigger state infinitely. Provided for SCPI standard compatibility reasons.	-
"Immediate"	Measures immediately, does not wait for trigger condition.	-
"Internal"	Uses the filtered and preprocessed measurement signal as trigger signal.	TRIGger:IMMediate
"Host Interface"	Uses the digital input signal supplied using a differential pair in the 8-pin sensor cable.	TRIGger:IMMediate

Trigger source	Description	Remote commands to initiate the measurement
"Trigger 2 I/O"	Uses the digital input signal supplied using the SMA connector.	TRIGger:IMMediate
"Bus (*TRG)"	Triggered by the remote command.	*TRG TRIGger:IMMediate

9.2.3 Dropout time

The dropout time is useful when dealing with signals with several active slots, for example GSM signals, see [Figure 9-1](#). When measuring in sync with the signal, a trigger event is to be produced at A, but not at B or C.

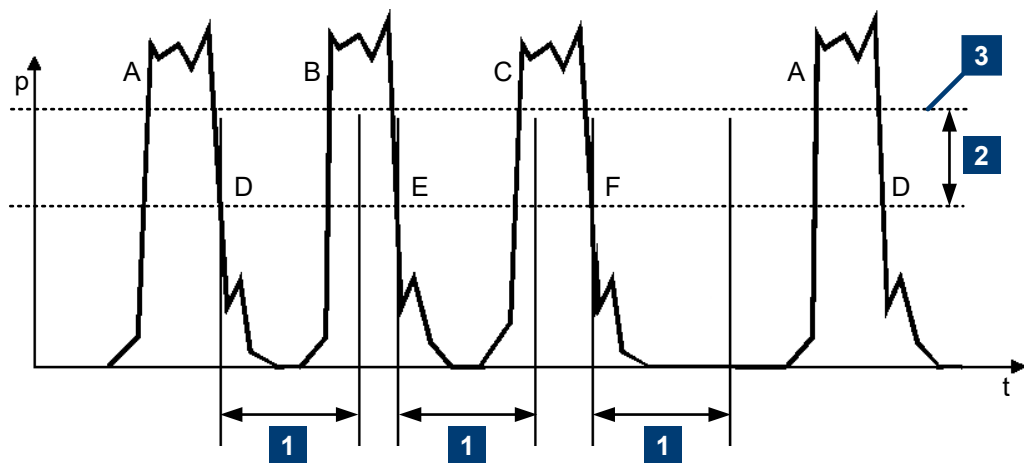

Figure 9-1: Significance of the dropout time

- 1 = Dropout time
- 2 = Trigger hysteresis
- 3 = Trigger level

The RF power between the slots is below the threshold defined by the trigger level and the trigger hysteresis. Therefore, the trigger hysteresis alone cannot prevent triggering at B or at C. Therefore, set the dropout time greater than the time elapsed between points D and B and between E and C, but smaller than the time elapsed between F and A. Thus, you ensure that triggering takes place at A.

Because the mechanism associated with the dropout time is reactivated whenever the trigger threshold is crossed, you can obtain also unambiguous triggering for many complex signals.

If you use a hold-off time instead of a dropout time, you can obtain stable triggering conditions - regular triggering at the same point. But you cannot achieve exclusive triggering at A.

9.2.4 Hold-off time

During the hold-off time, a period after a trigger event, all trigger events are ignored.

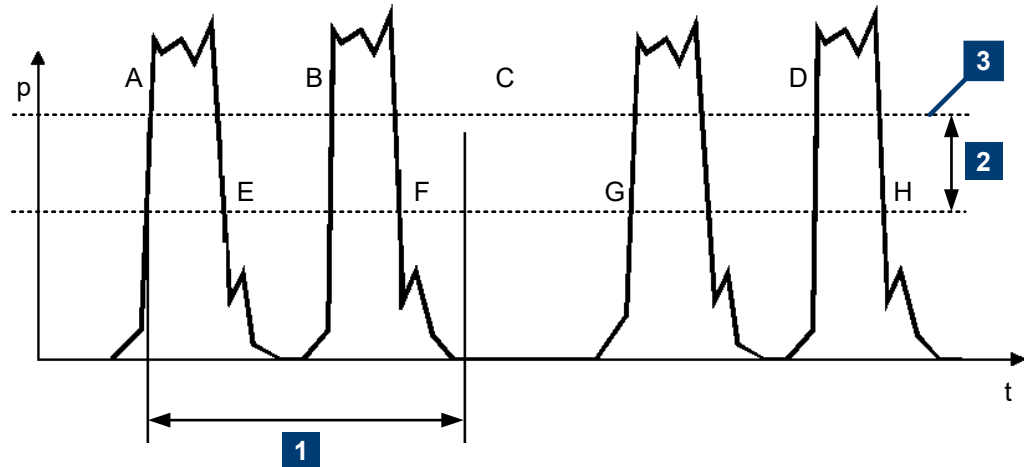

- 1 = Hold-off time
- 2 = Trigger hysteresis
- 3 = Trigger level

9.2.5 Trigger jitter

The R&S NRQ6 offers two methods to cope with the deviation from true periodicity.

- Compensate method
Compensation means resampling of trace result.
This method is only possible for bandwidths ≤ 80 MHz. Check the current state under `<Bandwidth>` or use `[SENSe<Sensor>:]BANDwidth:RESolution:CUV?`.
- Measure method
Does not perform resampling, but stores the measured trigger jitter. You can query the measured trigger jitter using `TRIGger:JITTer?`.
This method is not possible for bandwidths > 80 MHz if using an internal trigger condition. Check the current configuration using `TRIGger:JITTer:METHod:CUV?`. If `MEAS` is returned, this method can be used.

9.2.6 Trigger sender usage

If the R&S NRQ6 is the trigger sender, the R&S NRQ6 outputs a digital trigger signal in sync with its own trigger event. The trigger signal is output at the selected port, "Host Interface" or "Trigger 2 I/O".

Typically, the trigger sender uses its internal trigger source. But you can also trigger the trigger sender externally, because the R&S NRQ6 has two external trigger connectors.

If you trigger the trigger sender externally, use "Host Interface" as external trigger input port (trigger source) and "Trigger 2 I/O" as trigger sender output port or vice versa.

9.2.7 Trigger parameters

Access: main dialog of the web user interface > navigation pane > "Trigger"

Here, all available trigger settings are grouped. Some trigger settings are also available as measurement setting for quick access.

Continuous Average	Trigger Mode	Free Run	Stop	Trigger Level	Adjust	1000.000	pW
Trace	Trigger Source	Immediate		Trigger Delay		0.000	s
ACLR	Jitter Suppression	Compensate		Trigger Dropout		0.000	s
I/Q	Trigger Holdoff		0.000	Trigger Hysteresis		0.0	dB
Trigger	Trigger Sender Port	Host Interface		Trigger 2 I/O Impedance		High	
Correction	Trigger Sender State	Off		Sync. State		off	
Mixer							
Sensor							
System							

Trigger Mode.....	91
Trigger Level.....	92
Trigger Source.....	92
Trigger Delay.....	92
Jitter Suppression.....	92
Trigger Dropout.....	93
Trigger Holdoff.....	93
Trigger Hysteresis.....	93
Sender Port.....	93
Trigger 2 I/O Impedance.....	93
Sender State.....	94
Sync. State.....	94

Trigger Mode

Controls the trigger execution.

See also [Chapter 9.2.2, "Trigger sources"](#), on page 88.

"Auto" Automatic trigger event each 300 ms if no trigger event has occurred during this time interval.

"Single" Implies separately started measurements that are not triggered internally. Corresponds to the following commands:

- `INITiate:CONTinuous OFF`
- `INITiate[:IMMediate]`
- `TRIGger:SOURce ≠ INTernal`

Click "1 Trig" to enable and trigger the measurement.

- "Normal" Implies continuous measurements that are triggered internally. Corresponds to the following commands:
- `INITiate:CONTinuous ON`
 - `TRIGger:SOURce INTernal`
- Control the trigger event by the [Trigger Level](#) or by clicking "Force".
- "Free Run" Sets "Immediate" as trigger source and vice versa. If you want to stop the measurement, click "Stop". Restart the measurement with "Start".

Remote command:

This functionality has no direct remote control equivalent.

Trigger Level

Available if:

- "Auto", "Single" or "Normal" is set under [Trigger Mode](#).
- "Internal" is set under [Trigger Source](#).

Sets the trigger threshold for internal triggering. If [Attenuator](#) is set to 0 dB, the trigger level is restricted to ≤ -10.0 dBm. Values > -10.0 dBm cause a static error.

Click "Adjust" to adjust the trigger once automatically.

Remote command:

`TRIGger:LEVel`

`TRIGger:LEVel:AUTO`

Trigger Source

Sets the source for the trigger event. See [Trigger sources](#).

If "Free Run" is set under [Trigger Mode](#), "Immediate" is set as trigger source and cannot be changed.

Remote command:

`TRIGger:SOURce`

Trigger Delay

Available if:

- "Auto", "Single" or "Normal" is set under [Trigger Mode](#).
- "Internal", "External 1" or "External 2" is set under [Trigger Source](#).

Sets the delay between the trigger event and the beginning of the actual measurement (integration).

Remote command:

`TRIGger:DELAy`

Jitter Suppression

Defines the method how to cope with the misalignment between the trigger event and the sample point.

See [Chapter 9.2.5, "Trigger jitter"](#), on page 90.

Remote command:

`TRIGger:JITTer:METHod`

Trigger Dropout

Available if:

- "Auto", "Single" or "Normal" is set under [Trigger Mode](#).
- "Internal" is set under [Trigger Source](#).

Sets the dropout time for the internal trigger source. During this time, the signal power must exceed (negative trigger slope) or undercut (positive trigger slope) the level defined by the trigger level and trigger hysteresis. At least, this time must elapse before triggering can occur again.

See [Chapter 9.2.3, "Dropout time"](#), on page 89.

Remote command:

`TRIGger:DTIME`

Trigger Holdoff

Sets the hold-off time, a period after a trigger event during which all trigger events are ignored.

See [Chapter 9.2.4, "Hold-off time"](#), on page 90.

Remote command:

`TRIGger:HOLDoff`

Trigger Hysteresis

Available if:

- "Auto", "Single" or "Normal" is set under [Trigger Mode](#).
- "Internal" is set under [Trigger Source](#).

Sets the hysteresis. A trigger event occurs, if the trigger level:

- Falls below the set value on a rising slope.
- Rises above the set value on a falling slope.

Thus, you can use this setting to eliminate the effects of noise in the signal for the edge detector of the trigger system.

Remote command:

`TRIGger:HYSTeresis`

Sender Port

Effective only if the R&S NRQ6 is trigger sender:

- "On" is set under [Sender State](#).
- "Sender" is set under [Sync Mode](#).

Selects the port where the R&S NRQ6 outputs a digital trigger signal. See [Chapter 9.2.6, "Trigger sender usage"](#), on page 90.

Remote command:

`TRIGger:SENDER:PORT`

Trigger 2 I/O Impedance

Effective only if "External2" is set under [Trigger Source](#).

Sets termination resistance of the second external trigger input. Choose the setting that fits the impedance of the trigger source to minimize reflections on the trigger signals.

"High" ~10 kΩ

"Low" 50 kΩ

Remote command:

`TRIGger:EXTernal<2...2>:IMPedance`

Sender State

Enables or disables the trigger sender state. See [Chapter 9.2.6, "Trigger sender usage"](#), on page 90.

If enabled, select the output port for the trigger signal under [Sender Port](#).

Remote command:

`TRIGger:SENDER:STATE`

Sync. State

Usually used if "On" is set under [Sender State](#).

If enabled, blocks the external trigger bus as long as the sensor remains in the measurement state. Thus, ensures that a new measurement is only started after all sensors have completed their measurements.

The sync port is set by `TRIGger:SYNC:PORT`.

Make sure that the number of repetitions is the same for all sensors involved in the measurement. Otherwise, the trigger bus is blocked by any sensor that has completed its measurements before the others and has returned to the idle state.

See also [Chapter 9.2.1, "Trigger states"](#), on page 88.

Remote command:

`TRIGger:SYNC:STATE`

9.3 Correction settings

Remote command reference:

- [Chapter 12.7, "Calibrating and zeroing"](#), on page 138
- [Chapter 12.9.7, "Configuring the corrections"](#), on page 160

Contents:

- [Corrections in the RF path](#)..... 94
- [Corrections in the IF path](#).....96
- [Correction parameters](#)..... 99

9.3.1 Corrections in the RF path

You can set parameters that compensate for internal and external influences.

9.3.1.1 Noise correction

Each electronic system generates inherent noise that is added to the input noise. The *noise figure F* is the quotient of the signal-to-noise ratio at the input and output of an electronic system:

$$F = \text{SNR}_{\text{output}} / \text{SNR}_{\text{input}}$$

Expressed in dB as:

$$10 \times \log (\text{SNR}_{\text{output}} / \text{SNR}_{\text{input}})$$

If you enable the noise correction, the noise figure is subtracted from the measured power. For power measurements close to or in the noise floor, you can use the noise correction in continuous average and trace mode.

The noise figure varies with the frequency. The R&S NRQ6 uses a set of factory noise figures for different bandwidths. Alternatively, you can perform a zero calibration and use the determined noise figure until one of the following happens:

- Reboot
- Value change of:
 - Frequency
100 MHz frequency grid is used, exactly as in the DC offset correction.
 - Attenuation
0 dB or 30 dB
 - Resolution bandwidth
 - Resolution bandwidth filter type

In consequence of such changes, the determined noise figure is discarded and the set of factory noise figure values is applied again.

9.3.1.2 Zero calibration

In a zero calibration, you determine the correction data for your measurement setup. The R&S NRQ6 performs the following steps.

1. Measures the noise using the signal at the RF input. Therefore:
Turn off all test signals before zeroing. An active test signal during zeroing causes an error.
2. Enables the noise correction by applying the determined noise figure in [step 1](#).
See [Chapter 9.3.1.1, "Noise correction"](#), on page 95.
3. For measurements in zero-IF mode (RBW > 40 MHz), also performs [DC Zeroing](#).
See [Chapter 9.3.2.2, "DC zeroing"](#), on page 98.

Perform a new zero calibration if:

- Temperature has varied by more than 5 K.
- No zeroing was performed in the last 24 hours.

- Signals of very low power are to be measured, for instance, if the expected measured value is less than 10 dB above the noise level.

9.3.1.3 Accounting for external losses

Add a fixed level offset in dB using [Level Offset](#).

If you consider the attenuation of an attenuator located ahead of the R&S NRQ6 or the coupling attenuation of a directional coupler, use a positive offset. That means the R&S NRQ6 displays the power at the input of the attenuator or the directional coupler.

If you want to correct the influence of an amplifier connected ahead, use a negative offset.

9.3.1.4 S-parameter and S-gamma

Use remote control, see:

- [Chapter 12.9.7.4, "S-parameter corrections"](#), on page 163
- [Chapter 12.9.7.5, "S-gamma corrections"](#), on page 170

9.3.2 Corrections in the IF path

These corrections are suitable for measurements in zero-IF mode, with resolution bandwidths > 40 MHz.

9.3.2.1 DC rejection

Using the DC reject filter, you can suppress an inherent DC offset in the IF path.

The DC reject filter is a notch filter in the IF path. Its frequency response shows a deep notch with high selectivity:

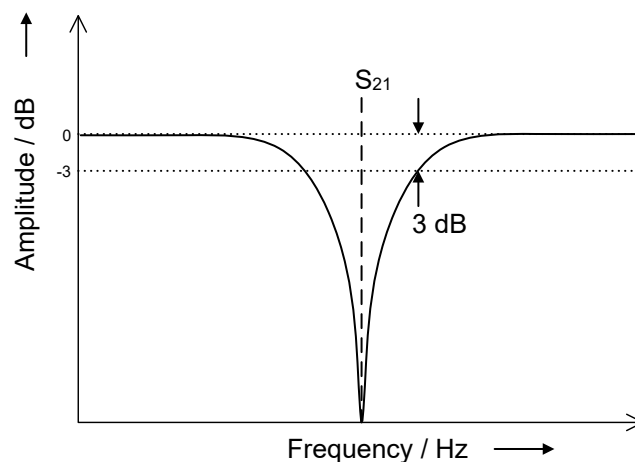

In the following example, the inherent noise spectrum in zero-IF mode is shown, with RBW = 100 MHz and attenuator = 0 dB. Fig.9-2 shows the noise spectrum without corrections. Fig.9-3 shows the noise spectrum with the DC reject filter enabled and the 3 dB frequency set to 1.166 kHz.

For measuring multicarrier signals in zero-IF mode at low signal levels, enable the DC reject filter and set the LO frequency of the R&S NRQ6 in a space between two carriers.

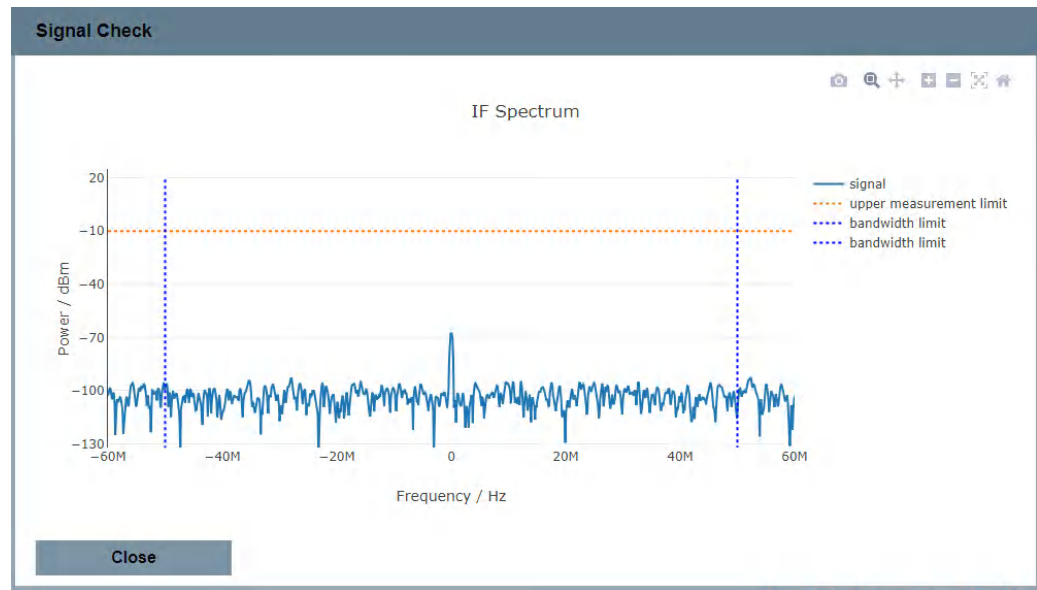

Figure 9-2: Inherent noise spectrum with DC reject filter disabled

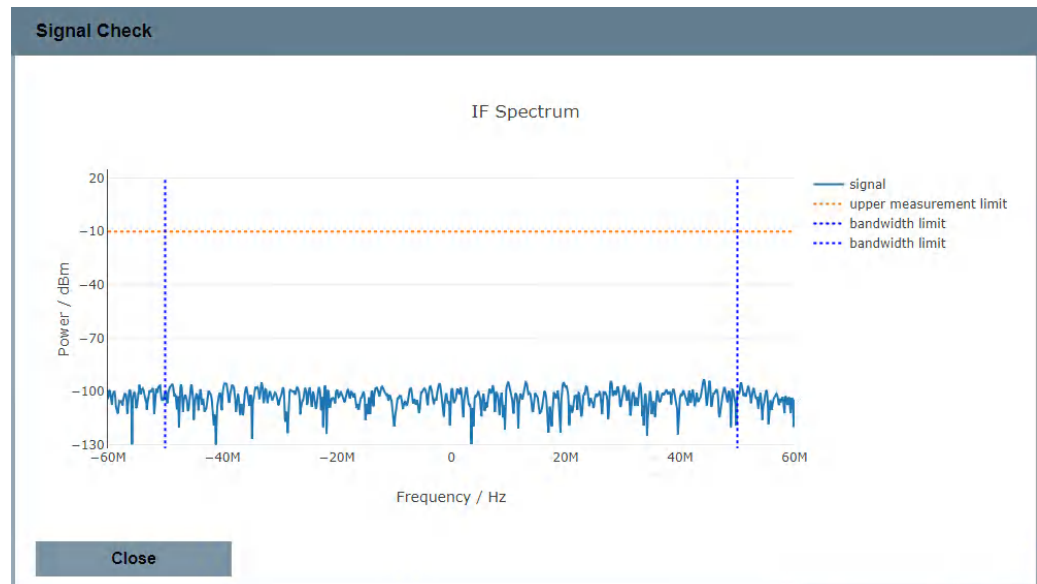

Figure 9-3: Inherent noise spectrum with DC reject filter enabled

9.3.2.2 DC zeroing

In zero-IF mode (RBW > 40 MHz), the R&S NRQ6 shows a large DC offset. This DC offset is caused by the reflection of the internal LO signal at the RF connector, leading to mixing products. This phenomenon is described in the data sheet as LO leakage at RF input connector. See also [Chapter 6.6.2, "LO leakage"](#), on page 47.

You can correct this offset using the DC offset calibration, so-called DC zeroing. In this calibration, the R&S NRQ6 measures and saves a DC offset value depending on the following parameter settings:

- Attenuator [<Level>](#)
0 dB or 30 dB
- Resolution [<Bandwidth>](#)
Equals 400 MHz or not. All RBWs ≠ 400 MHz count as one setting.
- Center [Frequency](#)
Starting from 50 MHz, the frequency range is divided into a 100 MHz frequency grid. Each 100 MHz range counts as one setting. So if you calibrate for a center frequency of 980 MHz, and then change the center frequency to 1020 MHz, still the same DC offset value applies.

As long as you keep the parameters within range, the R&S NRQ6 applies same DC offset value once it is determined. If you change one parameter out of range, the R&S NRQ6 does not apply the same DC offset value anymore. Calibrate for the new parameter settings to acquire a fitting DC offset value.

If you calibrate again for parameter settings for which there already exists a DC offset value, the R&S NRQ6 overwrites the old DC offset value with the new one. You can use the saved DC offset values as long as you do not reboot the R&S NRQ6.

Due to changes in the environmental conditions, it happens that the DC offset value does not fit anymore. If you are not sure of the quality, check the intermediate frequency (IF) spectrum using [Signal Check](#). If the DC offset is too large, calibrate again.

To calibrate the DC offset

1. Allow at least 10 minutes warm-up time before starting the DC zeroing.
2. Set up the R&S NRQ6 for the measurement, in all cases ensure that:
 - The DUT is connected to the RF connector as described in [Chapter 3.4, "Connecting to a DUT"](#), on page 15. For OTA measurements, ensure that the antenna is connected to the RF connector of the R&S NRQ6.
In contrast to zero calibration, you do not need to turn off all test signals, as long as the test signals do not have a large DC component in the IF band.
 - The current settings are fitting for the measurement that you want to perform.
3. Start DC zeroing.
Web user interface: ["DC Zeroing"](#) on page 101
Remote control: `CALibration<Channel>:IQOffset[:AUTO]`



Changing the DUT setup after the DC zeroing can result in a different mismatch, thus making the DC offset calibration invalid.

Further information:

- [Chapter 8.3.3, "DC zeroing in ACLR mode"](#), on page 72

9.3.3 Correction parameters

Access: main dialog of the web user interface > navigation pane > "Correction"

Continuous Average	RF Path	Zero Calibration	Zero	
Trace		Γ Correction	<input type="checkbox"/> Off	Magnitude <input type="text" value="0.0"/> Phase <input type="text" value="0.0°"/>
ACLR		Noise Correction	<input type="checkbox"/> Off	
I/Q		Level Offset	<input type="checkbox"/> Off	Normalize <input type="text" value="0.000"/> dB
Trigger				
Correction	IF Path	DC Reject Filter	<input type="checkbox"/> Off	Desired 3dB Frequency <input type="text" value="1.166"/> kHz Used 3dB Frequency <input type="text" value="1.166"/> kHz
Mixer		DC Zeroing	Zero	
Sensor				
System				

RF Path	99
L Zero Calibration	99
L Γ Correction	100
L <State>	100
L Magnitude	100
L Phase	100
L Noise Correction	100
L Level Offset	100
L <State>	100
L Normalize	100
L <Value>	100
IF Path	101
L DC Reject Filter	101
L <State>	101
L Desired 3dB Frequency	101
L Used 3dB Frequency	101
L DC Zeroing	101

RF Path

Groups the RF correction settings.

Zero Calibration ← RF Path

Click "Zero" to execute zeroing. See [Chapter 9.3.1.2, "Zero calibration"](#), on page 95.

Note:

Turn off all test signals before zeroing. An active test signal during zeroing causes an error.

Remote command:

`CALibration<Channel>:ZERO:AUTO`

Γ Correction ← RF Path

For background information, see [Chapter 12.9.7.5, "S-gamma corrections"](#), on page 170.

<State> ← Γ Correction ← RF Path

Enables or disables the use of the complex reflection coefficient of the signal source, Γ_{source} .

Remote command:

`[SENSe<Sensor>:]SGAMma:CORRection:STATe` on page 171

Magnitude ← Γ Correction ← RF Path

Sets the magnitude of the complex reflection coefficient of the source, Γ_{source} .

A value of 0.0 corresponds to an ideal matched source. A value of 1.0 corresponds to total reflection.

Remote command:

`[SENSe<Sensor>:]SGAMma:MAGNitude` on page 171

Phase ← Γ Correction ← RF Path

Sets the phase angle of the complex reflection coefficient of the source, Γ_{source} .

Remote command:

`[SENSe<Sensor>:]SGAMma:PHASe` on page 171

Noise Correction ← RF Path

For background information, see [Chapter 9.3.1.1, "Noise correction"](#), on page 95.

Enables or disables the noise correction.

Remote command:

`[SENSe<Sensor>:]POWER:NCORrection[:STATe]`

Level Offset ← RF Path

For background information, see [Chapter 9.3.1.3, "Accounting for external losses"](#), on page 96.

<State> ← Level Offset ← RF Path

Enables or disables the offset correction.

Remote command:

`[SENSe<Sensor>:]CORRection:OFFSet:STATe`

Normalize ← Level Offset ← RF Path

Available in continuous average mode.

Click this button to adopt the currently measured value as new level offset. You can use this function as a quick way to set up relative measurements.

<Value> ← Level Offset ← RF Path

Available if "On" is set under **<State>**.

Sets a fixed offset that is added to the measured value to account for external attenuation or amplification.

"-200.0" to "200.0"

Value in dB.

Remote command:

```
[SENSe<Sensor>:]CORRection:OFFSet
```

IF Path

Groups the IF correction settings.

DC Reject Filter ← IF Path

For background information, see [Chapter 9.3.2.1, "DC rejection"](#), on page 96.

<State> ← DC Reject Filter ← IF Path

Available for resolution bandwidths > 40 MHz (zero-IF mode).

Enables or disables the DC reject filter. Set the corner (cut-off) frequency points using [Desired 3dB Frequency](#).

Remote command:

```
[SENSe<Sensor>:]FILTer:DCReject[:STATe]
```

Desired 3dB Frequency ← DC Reject Filter ← IF Path

Enter the corner (cut-off) frequency of the DC reject filter.

"146.0 Hz" to Frequency range

"12.5 MHz"

Remote command:

```
[SENSe<Sensor>:]FILTer:DCReject:FCORner
```

Used 3dB Frequency ← DC Reject Filter ← IF Path

Displays the currently used corner frequency of the DC reject filter.

Remote command:

```
[SENSe<Sensor>:]FILTer:DCReject:FCORner:CUV?
```

DC Zeroing ← IF Path

Click "Zero" to compensate for the internal DC voltage offset. Recommended for measurements in zero-IF mode (RBW > 40 MHz). See [Chapter 9.3.2.2, "DC zeroing"](#), on page 98.

Remote command:

```
CALibration<Channel>:IQOFFset[:AUTO]
```

9.4 Mixer settings

The mixer is a central part of the R&S NRQ6, as shown in [Chapter 6.1, "Functional principle"](#), on page 42. The center frequency defines the mixing (intermediate) frequency in the downconversion process.

Remote command reference:

- [Chapter 12.9.8, "Configuring the mixer"](#), on page 172

Contents:

- [Local oscillator signal](#)..... 102
- [Mixer parameters](#)..... 102

9.4.1 Local oscillator signal

By default, the R&S NRQ6 generates its local oscillator (LO) signal internally. You can output the local oscillator signal at the LO connector and use it for other devices. Also, you can input an external signal at the LO connector and use it instead of the internal LO signal. For the frequency range, see [Table 9-2](#).

Make sure that you use the LO connector either as input or as output. Contradictory settings cause a static error.

Further information:

- [Chapter 7.2, "Frequency configuration"](#), on page 50
- [Chapter 4.8, "Local oscillator I/O \(LO\)"](#), on page 31

9.4.2 Mixer parameters

Access: main dialog of the web user interface > navigation pane > "Mixer"

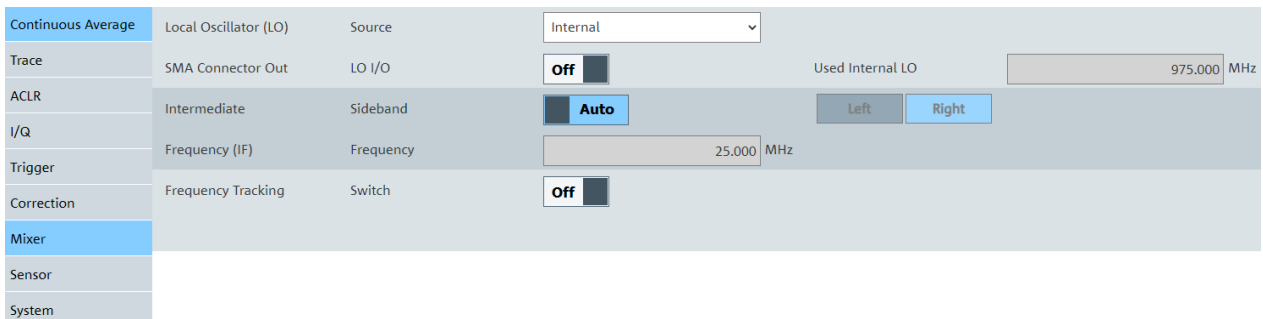

- [Local Oscillator \(LO\) - Source](#)..... 103
- [SMA Connector Out](#)..... 103
 - [LO I/O](#)..... 103
 - [Used Internal LO, Expected External LO](#)..... 103
- [Intermediate](#)..... 103
 - [Sideband](#)..... 103
 - [Left, Right](#)..... 103
- [Frequency \(IF\) - Frequency](#)..... 104
- [Frequency Tracking](#)..... 104
 - [Switch](#)..... 104
 - [Tracking Frequency](#)..... 104

Local Oscillator (LO) - Source

Sets the local oscillator source.

"Internal"	Uses the internal LO signal.
"External"	Uses the external LO signal fed into the LO connector. The internal LO generation is disabled. Enabling LO I/O at the same time causes a static error. The absence of an external LO signal at the LO connector also causes a static error.

Note:

The usage of the external sampling clock requires an external LO signal. To avoid setting conflicts, the following combination is not allowed:

- External sampling clock enabled
- Internal LO source

Remote command:

```
[SENSe<Sensor>:] FREQuency:CONVersion:MIXer:LO:SOURce
```

SMA Connector Out

Groups the parameters of the local oscillator output.

LO I/O ← SMA Connector Out

Enables or disables the output of the local oscillator signal. See [Chapter 9.4.1, "Local oscillator signal"](#), on page 102.

"Off"	No signal is output. You can use the LO connector as an input.
"On"	LO signal is output. Setting Local Oscillator (LO) - Source to "External" at the same time causes a static error.

Remote command:

```
[SENSe<Sensor>:] FREQuency:CONVersion:MIXer:LO:OUTPut[:STATe]
```

Used Internal LO, Expected External LO ← SMA Connector Out

Displays the currently used local oscillator frequency.

Remote command:

```
[SENSe<Sensor>:] FREQuency:CONVersion:MIXer:LO[:CUV]?
```

Intermediate

Groups settings of the intermediate frequency sideband.

Sideband ← Intermediate

Enables or disables the automatic setting of the intermediate frequency sideband.

Remote command:

```
[SENSe<Sensor>:] FREQuency:CONVersion:MIXer:IF:SIDeband:AUTO[:STATe]
```

Left, Right ← Intermediate

Available if "Manual" is set under ["Sideband"](#) on page 103.

Sets the currently used intermediate frequency sideband.

Remote command:

[SENSe<Sensor>:] FREQuency:CONVersion:MIXer:IF:SIDeband

Frequency (IF) - Frequency

Displays the currently used intermediate frequency.

Remote command:

[SENSe<Sensor>:] FREQuency:CONVersion:MIXer:IF[:CUV]?

Frequency Tracking

For background information, see [Chapter 7.2.1, "Frequency tracker"](#), on page 50.

Switch ← Frequency Tracking

Enables or disables the frequency tracker.

Remote command:

[SENSe<Sensor>:] FREQuency:TRACk

[SENSe<Sensor>:] FREQuency:TRACk:CUV[:STATe]?

Tracking Frequency ← Frequency Tracking

Available if "On" is set under [Switch](#).

Displays the tracking frequency.

Remote command:

[SENSe<Sensor>:] FREQuency:TRACk:FREQuency?

9.5 Sensor settings

Remote command reference:

- [Chapter 12.9.9, "Configuring the sensor"](#), on page 174

Contents:

- [Clock source configuration](#)..... 104
- [Sensor parameters](#)..... 105

9.5.1 Clock source configuration

By default, the R&S NRQ6 generates its conversion frequency, sampling clock and reference clock internally. Alternatively, you can use external clock sources, see [Table 9-2](#).

Table 9-1: Internal clock frequencies

Reference clock	10 MHz
Sampling clock	119 MHz to 121 MHz
Conversion frequency	70 MHz to 6.03 GHz

Table 9-2: External clock sources

Used connector	Input frequency range	Output frequency range
Host interface connector (USB host) See Chapter 4.4, "Host interface" , on page 30.	20 MHz	No output
REF connector See Chapter 4.6, "Reference I/O (REF)" , on page 30.	10 MHz	10 MHz
CLK connector See Chapter 4.7, "Clock I/O (CLK)" , on page 31.	119 MHz to 121 MHz	119 MHz to 121 MHz
LO connector See Chapter 4.8, "Local oscillator I/O (LO)" , on page 31.	70 MHz to 6.03 GHz	70 MHz to 6.03 GHz

9.5.2 Sensor parameters

Access: main dialog of the web user interface > navigation pane > "Sensor"

Continuous Average	Reference Oscillator	Source	Internal	
Trace		Reference Input	10.000	MHz
ACLR	SMA Connector Out	Reference I/O	<input type="checkbox"/> Off	Output Frequency (10 MHz)
I/Q	SMA Connector Out	Clock I/O	<input type="checkbox"/> Off	Output Frequency (119-121 MHz)
Trigger				
Correction	Clock Distribution Mode	Use Ext. Sampling Clock	<input type="checkbox"/> Off	External LO Source Required
Mixer				
Sensor				
System				

Reference Oscillator.....	105
L Source.....	105
L Reference Input.....	106
SMA Connector Out.....	106
L Reference I/O.....	106
L Clock I/O.....	106
Clock Distribution Mode - Use Ext. Sampling Clock.....	106

Reference Oscillator

Groups the reference oscillator settings.

Source ← Reference Oscillator

Sets the source of the reference oscillator. See [Chapter 9.5.1, "Clock source configuration"](#), on page 104.

Remote command:

```
[SENSe<Sensor>:]ROSCillator:SOURce
```

Reference Input ← Reference Oscillator

Available if "Reference I/O" is set under [Source](#).

Sets the frequency of the reference clock signal that is supplied at the REF connector. A value other than 10 MHz is not recommended. See also [Table 9-2](#).

Remote command:

```
[SENSe<Sensor>:]ROSCillator:REFio:FREQuency
```

SMA Connector Out

Groups the output configuration.

Reference I/O ← SMA Connector Out

Available if "Internal" or "Host Interface" is set under [Source](#). Automatically disabled if "Reference I/O" is set under [Source](#).

If the REF connector is used as an output, enables or disables the output signal.

See also [Table 9-2](#).

Remote command:

```
[SENSe<Sensor>:]ROSCillator:REFio:OUTPut[:STATe]
```

Clock I/O ← SMA Connector Out

If the CLK connector is used as an output, enables or disables the output signal.

See also [Table 9-2](#).

Remote command:

```
[SENSe<Sensor>:]SAMPLing:CLKio:OUTPut[:STATe]
```

Clock Distribution Mode - Use Ext. Sampling Clock

Requires the phase coherent measurements option (R&S NRQ6-K3).

Configures the usage of the external sampling clock.

Note:

The usage of the external sampling clock requires an external LO signal. To avoid setting conflicts, the following combination is not allowed:

- External sampling clock enabled
- Internal LO source

"Off" Default setting. Uses the internally generated 10 MHz reference signal to derive the sampling clock signal.

"On" Enables the use of an external sampling clock supplied at the clock I/O (CLK) connector.

Remote command:

```
[SENSe<Sensor>:]ROSCillator:PASSthrough
```

10 System configuration

The settings for the system configuration do not directly affect the measurement.

Remote command reference:

- [Chapter 12.10, "Configuring the system"](#), on page 176

10.1 Option management

Optional features are available as options and are part of the firmware package. If you want to use an optional feature, you buy the option and, in return, receive a license key. Using the license key, you can activate the option as described in [Chapter 10.1.1, "Installing a license key"](#), on page 107.

You can also use the license key to deactivate the option but keep in mind that you cannot use the same license key to activate the option again. If you want to reactivate an option, contact the Rohde & Schwarz service center to request a new license key.

For detailed information on available options, see the data sheet or visit:

www.rohde-schwarz.com/brochure-datasheet/NRQ6

10.1.1 Installing a license key

Use one of the following methods:

- Entering the license key manually.
See ["To install the license key"](#) on page 107.
- Using an RSI file.
See ["To install the license key"](#) on page 107.
- Using remote control.
See `SYSTem:LIcense:KEY` on page 186 or `SYSTem:LIcense:XML` on page 186

To install the license key

1. Make sure that the most recent firmware version is installed.
2. Open the web user interface, see ["To display the Web user interface"](#) on page 35.
3. In the navigation pane of the main dialog, select "System".
4. Click "Enter License Key".
The "Enter License Key" dialog is displayed.
See ["Enter License Key"](#) on page 110.
5. If you install the license key manually:
 - a) Under "License Key", enter the license key from the software option list supplied with the option.

6. If you use an RSI file:
 - a) Copy the RSI file delivered with the option into a folder that you can access with your R&S NRQ6.
 - b) Click "Browse License File".
 - c) Select the RSI file you want to install.
7. Click "Apply".
8. Click "Reboot".
The R&S NRQ6 performs a reboot.
9. Check whether the option is active. The name of the option is displayed under "Installed Options", for example "NRQ-K1".

10.2 System parameters

Access: main dialog of the web user interface > navigation pane > "System"

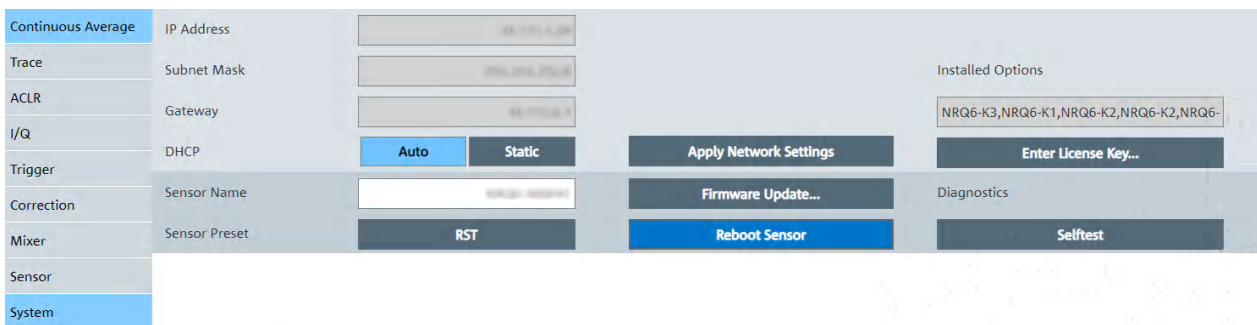

IP Address.....	108
Subnet Mask.....	109
Gateway.....	109
DHCP.....	109
Apply Network Settings.....	109
Sensor Name.....	109
Sensor Preset.....	109
Firmware Update.....	110
Reboot Sensor.....	110
Installed Options.....	110
Enter License Key.....	110
L Device ID.....	111
L License Key.....	111
L Browse License File.....	111
L Apply.....	111
L Reboot.....	111
L Diagnostics - Selftest.....	111

IP Address

Sets the IP address of the sensor.

If "Auto" is set under [DHCP](#), the parameter is read-only.

Remote command:

```
SYSTem:COMMunicate:NETWork:IPADdress
```

Subnet Mask

Sets the subnet mask.

The subnet mask consists of four number blocks separated by dots. Every block contains 3 numbers in maximum.

If "Auto" is set under [DHCP](#), the parameter is read-only.

Remote command:

```
SYSTem:COMMunicate:NETWork:IPADdress:SUBNet:MASK
```

Gateway

Sets the address of the default gateway, that means the router that is used to forward traffic to destinations beyond the local network. This router is on the same network as the power sensor.

If "Auto" is set under [DHCP](#), the parameter is read-only.

Remote command:

```
SYSTem:COMMunicate:NETWork:IPADdress:GATeway
```

DHCP

Sets how the IP address is assigned.

"Auto" Assigns the IP address automatically, provided the network supports the dynamic host configuration protocol (DHCP).

"Static" Enables assigning the IP address manually.

Remote command:

```
SYSTem:COMMunicate:NETWork:IPADdress:MODE
```

Apply Network Settings

Applies the changes of the network settings to the sensor.

Sensor Name

Sets the sensor name. The sensor name is displayed in the title bar of the web user interface, see (1) in [Figure 5-1](#).

If you do not specify a sensor name, the hostname is used as default. See also [SYSTem:COMMunicate:NETWork\[:COMMON\]:HOSTname](#) on page 179.

Remote command:

```
SYSTem[:SENSor]:NAME
```

Sensor Preset

Click the "RST" button to perform a preset. The R&S NRQ6 stops the running measurement, changes to the continuous average measurement and awaits the start of a new measurement.

Use the preset functionality to set the R&S NRQ6 to a well defined state. This allows you to change parameter values from well defined starting point.

Remote command:

```
*RST
```

Firmware Update

Opens a dialog to start the firmware update. For further information, see [Chapter 11.2.1, "Using the web user interface"](#), on page 112.

Alternatively, you can the Firmware Update for NRP Family program. See [Chapter 11.2.2, "Using the Firmware Update for NRP Family program"](#), on page 113.

Remote command:

```
SYSTem:FWUPdate  
SYSTem:FWUPdate:STATus?
```

Reboot Sensor

Reboots the R&S NRQ6. When the reboot is completed, press [F5] to reload the web browser page.

Remote command:

```
SYSTem:REBoot
```

Installed Options

Lists all software options that are activated on the R&S NRQ6. See also [Chapter 10.1, "Option management"](#), on page 107.

Remote command:

```
*OPT?
```

Enter License Key

Click the "Enter License Key" button to open the corresponding dialog.

Enter License Key (Reboot Required)

Device ID	1421.3509K02/900026
License Key	

Browse License File

Apply **Reboot** **Close**

Further information:

- [Chapter 10.1, "Option management"](#), on page 107
- [Chapter 10.1.1, "Installing a license key"](#), on page 107

Device ID ← Enter License Key

Displays the identification number that is unique for each R&S NRQ6. The string has the following structure:

1421.3509K02/<serial number>

You need the device ID to order an option.

Remote command:

`SYSTem:INFO?`

License Key ← Enter License Key

Enter the license key for the option.

Remote command:

`SYSTem:LICense:KEY`

Browse License File ← Enter License Key

Opens the file manager to select the license file, an RSI file.

Remote command:

`SYSTem:LICense:XML`

Apply ← Enter License Key

Applies the changes and closes the dialog.

Reboot ← Enter License Key

Reboots the R&S NRQ6 to complete a license key installation.

Remote command:

`SYSTem:REBoot`

Diagnostics - Selftest ← Enter License Key

Click "Selftest" to start a selftest.

Note:

During the selftest, do not apply a signal because this can cause erroneous test results.

After the selftest is completed, the results are displayed. For detailed information, see [Chapter 15.4, "Performing a selftest"](#), on page 210.

Remote command:

`TEST:SENSor?`

11 Firmware update

- [Preparing the update](#)..... 112
- [Updating the firmware](#)..... 112

11.1 Preparing the update

Firmware of R&S power sensors generally has an *.rsu extension, RSU meaning Rohde & Schwarz update.

To download the update file

1. Download the most recent firmware version from the Rohde & Schwarz homepage on the Internet, since the CD-ROM delivered with the power sensor contains the firmware dating from the time of delivery. The latest firmware update files are available at:
www.rohde-schwarz.com/en/firmware/nrq6/.
2. If the *.rsu file is packed in a *.zip archive, extract it.
3. Save the *.rsu file on the computer.

11.2 Updating the firmware

Do not interrupt the firmware update because an interruption can lead to missing or faulty firmware. Take special care not to disconnect the power supply while the update is in progress. Interrupting the power supply during the firmware update most likely leads to an unusable power sensor that needs to be sent in for maintenance.

You can use the following methods to update the firmware installed on the R&S NRQ6.

11.2.1 Using the web user interface

The operating concept of the web user interface is described in [Chapter 5.2, "Browser-based user interface"](#), on page 34.

1. Connect the power sensor to the computer as described in ["To connect to a LAN PoE+ interface"](#) on page 16.
2. Open the web user interface as described in [Chapter 5.2, "Browser-based user interface"](#), on page 34.
3. In the navigation pane, select "System".
4. Click "Firmware Update".

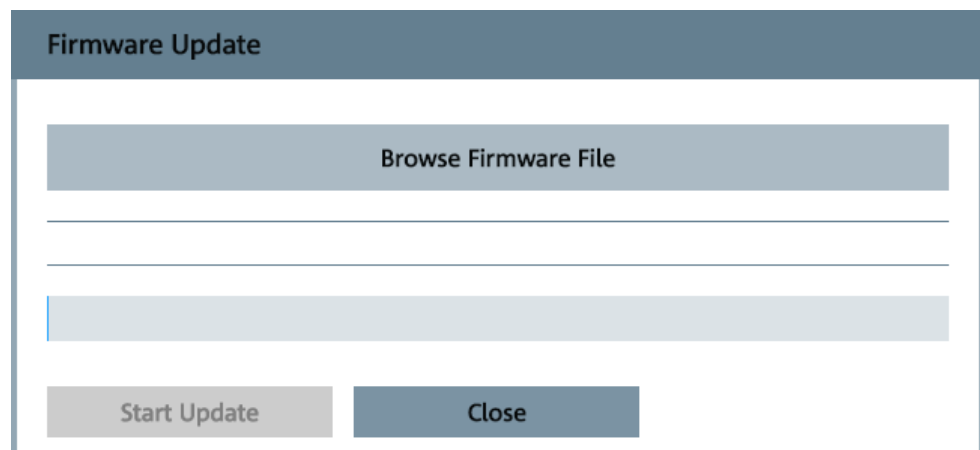

5. Click "Browse" to select the *.rsu file for upload.
The selected *.rsu is displayed, for example NRQx_02.20.20072802.rsu.
6. Click "Start Update".
During the update process, a progress bar is displayed. If a message is displayed that the connection is lost, click "Close and Reload".
When the update is completed, the firmware version displayed in the title bar is the same as in the name of the *.rsu file.

11.2.2 Using the Firmware Update for NRP Family program

The Firmware Update for NRP Family program is part of the R&S NRP Toolkit for Windows. See also [Chapter 5.1, "R&S NRP Toolkit"](#), on page 32.



You can perform a firmware update with Firmware Update for NRP Family only if the power sensor is recognized as a VISA device.

To check the prerequisites

1. Ensure that a recent VISA software is installed on the computer.
2. Ensure that the R&S NRP Toolkit for Windows is installed on the computer. See [Chapter 5.1, "R&S NRP Toolkit"](#), on page 32.

To update the firmware over LAN

1. Ensure that the prerequisites are fulfilled. See ["To check the prerequisites"](#) on page 113.
2. Connect the power sensor to the computer as described in [Chapter 3.6.1, "Computer using a LAN connection"](#), on page 17.
3. Start the Firmware Update for NRP Family program:
"Start" menu > "NRP-Toolkit" > "Firmware Update".

- Under "Hostname, IP Address or Serial Port", enter the hostname or the IP address of the power sensor you want to update.

If you have updated the firmware on your power sensor before, the hostname or address is displayed.

- Click "Check and Add".

Under "Device", the connection type and hostname are displayed.

Under "Identification", the following information is displayed: manufacturer, type, serial number, current firmware version.

- In the "Firmware" field, enter the full path and filename of the update file. Alternatively, click **...** next to the field and select the path.

If you have updated the firmware on your power sensor before, path and filename are displayed.

- Click "Update".

During the update process, a progress bar and status information are displayed.

- Check if the update was successful. The firmware version in the "Identification" field must match the version you selected in the "Firmware" field.

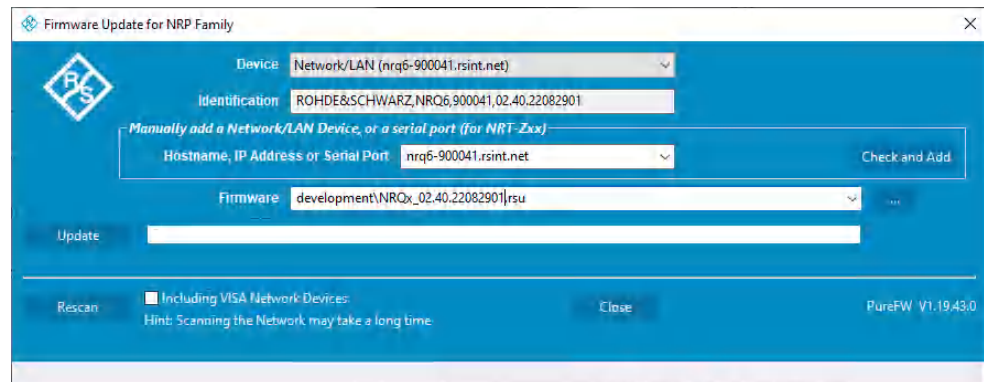

9. If the update is not successful, check whether all necessary drivers are installed on the computer. For example, if the VISA library is not installed, no VISA power sensor is accessible. For more details, see ["To check the prerequisites"](#) on page 113.
10. If you use the web user interface to operate the R&S NRQ6, press [F5] to reload the web page.

To update the firmware over USB

1. Check the prerequisites. See ["To check the prerequisites"](#) on page 113.
2. Connect the power sensor to the computer as described in [Chapter 3.6.2, "Computer using a USB connection"](#), on page 22.
3. Start the Firmware Update for NRP Family program:
"Start" menu > "NRP-Toolkit" > "Firmware Update".

The program automatically starts scanning for R&S power sensors connected via USB.

When the scan is completed, all recognized power sensors are listed under "Device".

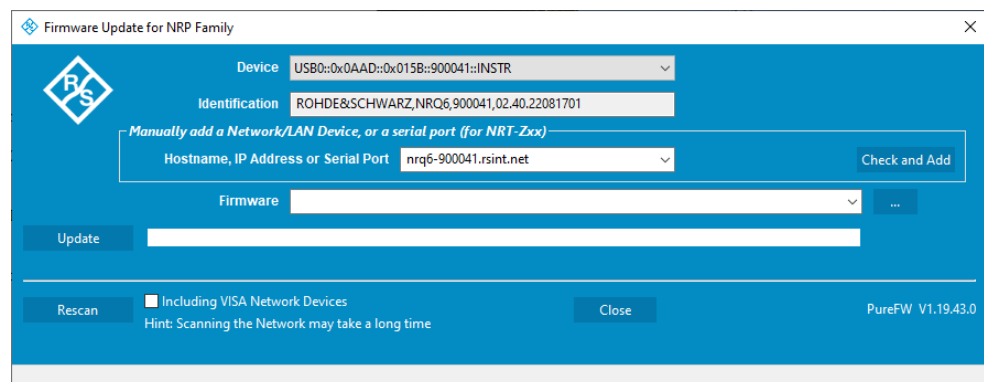

4. If the power sensor you want to update is not listed, perform one of the following actions:
 - a) Click "Rescan" to search for attached power sensors.

- b) Check whether all necessary drivers are installed on the computer.
For example, if the VISA library is not installed on the computer, no VISA power sensor is accessible.
5. Under "Device", select the power sensor you want to update.
The "Hostname, IP Address or Serial Port" field is not used during this procedure. Therefore, leave it empty.
6. In the "Firmware" field, enter the full path and filename of the update file. Alternatively, click  next to the field.
7. Click "Update".
During the update process, a progress bar is displayed.
The update sequence can take a couple of minutes. When the update has been completed, a message is displayed.
8. Confirm the message.
The firmware version under "Identification" is updated to the version that you have loaded.
9. Ensure that the firmware version displayed in "Identification" matches the version in the RSU filename displayed in "Firmware".

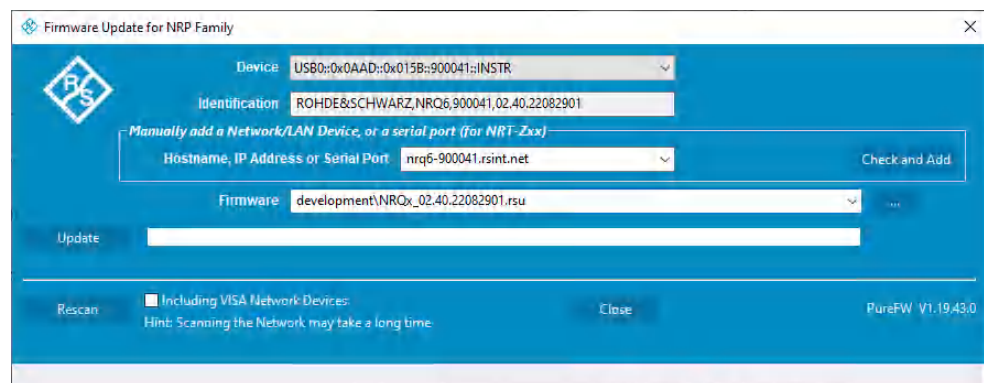

10. If you use the web user interface to operate the R&S NRQ6, press [F5] to reload the web page.

11.2.3 Using remote control

If you want to integrate a firmware update function in an application, use [SYSTEM:FWUpdate](#) on page 182.

Example:

You want to update your R&S NRQ6 with the `NRQx_02.20.20072802.rsu` file. This file has a size of 10242884 bytes.

To send the file to the power sensor for updating the firmware, your application has to assemble a memory block containing:

```
SYST:FWUP <block_data>
```

The `<block_data>` are definite length-arbitrary block data as described in [SYSTem:FWUPdate](#) on page 182.

The size of the file is 10242884. This number has 8 digits. Thus, the `<block_data>` consist of the following:

- #
- 8
How many digits follow to specify the file size.
- 10242884
Number that specifies the file size.
- <file_contents>
Contents of the *.rsu file, byte-by-byte
- 0x0a
Delimiter

In this example, you write exactly 10242905 bytes to the R&S NRQ6, for example by using a 'viWrite()' function.

The 10242905 bytes result from the values of the list above:

$$9 + 1 + 1 + 1 + 1 + 8 + 10242884 + 1$$

In a (pseudo) string notation, the memory block looks like this:

```
SYST:FWUP #810242884<file_contents>0x0a,
```

12 Remote control commands

In the following sections, all commands implemented in the power sensor are listed according to the command system and then described in detail. For the most part, the notation used complies with SCPI specifications.



The description of each command mainly contains the specifics for remote control. Follow the link under "Manual operation" for detailed information on the values and background information.

Further information:

- [Chapter 14.1, "Remote control interfaces and protocols"](#), on page 193
- [Chapter 14, "Remote control basics"](#), on page 193

12.1 Conventions used in SCPI command descriptions

The following conventions are used in the remote command descriptions:

- **Command usage**
If not specified otherwise, commands can be used both for setting and for querying parameters.
If a command can be used for setting or querying only, or if it initiates an event, the usage is stated explicitly.
- **Parameter usage**
If not specified otherwise, a parameter can be used to set a value and it is the result of a query.
Parameters required only for setting are indicated as **Setting parameters**.
Parameters required only to refine a query are indicated as **Query parameters**.
Parameters that are only returned as the result of a query are indicated as **Return values**.
- **Conformity**
Commands that are taken from the SCPI standard are indicated as **SCPI confirmed**. All commands used by the R&S NRQ6 follow the SCPI syntax rules.
- **Asynchronous commands**
A command which does not automatically finish executing before the next command starts executing (overlapping command) is indicated as an **Asynchronous command**.
- **Reset values (*RST)**
Default parameter values that are used directly after resetting the instrument (*RST command) are indicated as ***RST** values, if available.
- **Default unit**
The default unit is used for numeric values if no other unit is provided with the parameter.

Units

For physical quantities, you can enter the unit. Only basic units are allowed and recognized.

Table 12-1: Units

Basic unit	Also noted as
Hz	Frequency or HZ
s	Seconds
W	Watts
degrees	Angle
PCT	Percent
dB	DB
dBm	DBM
dBuV	DBUV

12.2 Common commands

The common commands are taken from the IEEE 488.2 (IEC 625–2) standard. The headers of these commands consist of an asterisk * followed by three letters.

*CLS.....	119
*ESE.....	120
*ESR?.....	120
*IDN?.....	120
*IST?.....	120
*OPC.....	120
*OPT?.....	121
*PRE.....	121
*RCL.....	121
*RST.....	121
*SAV.....	122
*SRE.....	122
*STB?.....	122
*TRG.....	122
*TST?.....	122
*WAI.....	123

*CLS

Clear status

Resets the following:

- Status byte (STB)
- Standard event register (ESR)

- EVENT part of the QUEStionable and the OPERation register
- Error/event queue

The command does not alter the ENABle and TRANsition parts of the registers.

Usage: Event

*ESE <register>

Event status enable

Sets the event status enable register to the specified value. The query returns the contents of the event status enable register in decimal form.

Parameters:

<register>	Range:	0 to 255
	*RST:	0

*ESR?

Event status read

Returns the contents of the event status register in decimal form (0 to 255) and then sets the register to zero.

Usage: Query only

*IDN?

Identification

Returns a string containing information on the identity of the power sensor (device identification code). In addition, the version number of the installed firmware is indicated.

Usage: Query only

*IST?

Individual status

Note:

Do not apply a signal while sending this command.

Returns the current value of the IST flag in decimal form. The IST flag is the status bit which is sent during a parallel poll.

Usage: Query only

*OPC

Operation complete

Sets bit 0 in the event status register when all preceding commands have been executed. Send this command at the end of a program message. It is important that the read timeout is set sufficiently long.

The query always returns 1 because the query waits until all previous commands are executed.

*OPC? basically functions like *WAI, but also returns a response. The response is an advantage, because you can query the execution of commands from a controller program before sending new commands. Thus preventing overflow of the input queue when too many commands are sent that cannot be executed.

*OPT?

Option identification

Returns a comma-separated list of installed options.

Usage: Query only

Manual operation: See "[Installed Options](#)" on page 110

*PRE <register>

Parallel poll register enable

Sets the parallel poll enable register to the specified value or queries the current value.

Parameters:

<register>	Range:	0 to 255
	*RST:	0

*RCL <number>

Recall

Calls the device state which has been stored with the *SAV command under the specified number.

Setting parameters:

<number>	Range:	0 to 9
	*RST:	0

Usage: Setting only

*RST

Reset

Sets the instrument to a defined default status. The default settings are indicated in the description of commands.

The command corresponds to the [SYSTem:PRESet](#) on page 187 command.

Usage: Event

Manual operation: See "[Sensor Preset](#)" on page 109

***SAV** <number>

Save

Stores the current device state under the specified number.

Setting parameters:

<number> Range: 0 to 9
 *RST: 0

Usage: Setting only

***SRE** <register>

Service request enable

Sets the service request enable register to the specified value. This command determines under which conditions a service request is triggered.

Parameters:

<register> Range: 0 to 255
 *RST: 0

***STB?**

Status byte

Returns the contents of the status byte in decimal form.

Usage: Query only

***TRG**

Trigger

Triggers a measurement if the following conditions are met:

- Power sensor is in the waiting for trigger state.
- Trigger source is set to BUS.

Usage: Event

***TST?**

Selftest

Triggers a selftest of the R&S NRQ6 and outputs the result. 0 indicates that no errors have occurred.

Usage: Query only

***WAI**

Wait to continue

Prevents the execution of the subsequent commands until all preceding commands have been executed and all signals have settled.

Usage: Event

12.3 Adapting to the test signal

These commands are valid for all measurement modes. They take the signal and its properties into account.

Further information:

- [Chapter 6, "Measurement basics"](#), on page 42

Web user interface:

- [Chapter 7, "Adapting to the test signal"](#), on page 49

Remote commands:

[SENSe<Sensor>:]ADJust[:ALL].....	123
[SENSe<Sensor>:]BANDwidth:INFO?.....	123
[SENSe<Sensor>:]BANDwidth:NOISe?.....	124
[SENSe<Sensor>:]BANDwidth:RESolution.....	124
[SENSe<Sensor>:]BANDwidth:RESolution:CUV?.....	124
[SENSe<Sensor>:]BANDwidth:RESolution:TYPE.....	125
[SENSe<Sensor>:]BANDwidth:RESolution:TYPE:AUTO[:STATe].....	125
[SENSe<Sensor>:]BANDwidth:SRATe.....	125
[SENSe<Sensor>:]BANDwidth:SRATe:CUV?.....	126
[SENSe<Sensor>:]BANDwidth:VARiable.....	126
[SENSe<Sensor>:]FREQUency[:CENTer].....	126
[SENSe<Sensor>:]INPut:ATTenuation.....	126
[SENSe<Sensor>:]INPut:ATTenuation:AUTO.....	127

[SENSe<Sensor>:]ADJust[:ALL] <state>

Adjusts center frequency and bandwidth settings to the test signal. Executed once.

Parameters:

<state> *RST: OFF

Example: ADJ ONCE

Manual operation: See "[Autoset](#)" on page 57

[SENSe<Sensor>:]BANDwidth:INFO? [<item>]

Queries information about the currently used resolution bandwidth filter.

Query parameters:

<item> String consisting of:
<Filter Type>,<fPass>,<f3db>,<fStop>

Example:

```
BAND:INFO?
Query
"Filter Type:FLAT,fPass:2e+07,f3db:
2.22222e+07,fStop:2.44444e+07"
Response
```

Usage: Query only

Manual operation: See "<Filter type>" on page 59

[SENSe<Sensor>:]BANDwidth:NOISE?

Queries the effective noise bandwidth, which depends on the bandwidth and the type of the set resolution bandwidth filter.

Usage: Query only

[SENSe<Sensor>:]BANDwidth:RESolution <bandwidth>

Effective if [SENSe<Sensor>:]BANDwidth:TYPE RESolution is set.

Sets the resolution bandwidth as floating point value.

Parameters:

<bandwidth> If [SENSe<Sensor>:]BANDwidth:VARIABLEOFF is set, only discrete steps are available. The entered value is rounded to the next value.
The filter bandwidth refers to the RBW display value in [Table 7-4](#) and its definition varies with the filter type. Each type has its own steps. See also [Chapter 7.3.3, "Choosing the correct filter type"](#), on page 54.
Range: 10 to 400e6
*RST: 25e6
Default unit: Frequency

Example: BAND:RES 40000000

Manual operation: See "<Bandwidth>" on page 59

[SENSe<Sensor>:]BANDwidth:RESolution:CUV?

Queries the currently used resolution bandwidth.

Example: BAND:RES:CUV?

Usage: Query only

Manual operation: See "<Bandwidth>" on page 59

[SENSe<Sensor>:]BANDwidth:RESolution:TYPE <select>

Effective if [SENSe<Sensor>:]BANDwidth:TYPE RESolution is set.

Sets the filter type for resolution bandwidth filter. The filter bandwidth is not affected.

See also [Chapter 7.3.1, "Filter characteristics"](#), on page 52.

If you want to set the filter type automatically, use [SENSe<Sensor>:]BANDwidth:RESolution:TYPE:AUTO[:STATe] on page 125.

Parameters:

<select> FLAT | NORMal | LTE | W3GPp
*RST: FLAT

Example: BAND:RES:TYPE FLAT

Manual operation: See "[Filter type](#)" on page 59

[SENSe<Sensor>:]BANDwidth:RESolution:TYPE:AUTO[:STATe] <state>

Effective if [SENSe<Sensor>:]BANDwidth:TYPE RESolution is set.

If enabled, sets the filter type suitable for the currently chosen measurement mode and bandwidth.

You can query the selected filter type using [SENSe<Sensor>:]BANDwidth:RESolution:TYPE on page 125.

Parameters:

<state> ON | OFF
*RST: ON

Example: BAND:RES:TYPE:AUTO ON

Manual operation: See "[Autoset](#)" on page 57
See "[State](#)" on page 59

[SENSe<Sensor>:]BANDwidth:SRATe <value>

Effective if [SENSe<Sensor>:]BANDwidth:TYPE SRATe is set.

Sets the desired value for the sample rate input.

Parameters:

<value> Range: 50 to 120e6
*RST: 22.6e6
Default unit: Frequency

Example: BAND:SRAT 22600000

Manual operation: See "[Desired Sample Rate](#)" on page 79

[SENSe<Sensor>:]BANDwidth:SRATe:CUV?

Queries the currently used sample rate.

Example: BAND:SRAT:CUV?
Query
2.260000E+07
Response

Usage: Query only

Manual operation: See "[Used Sample Rate](#)" on page 79

[SENSe<Sensor>:]BANDwidth:VARiable <state>

Enables or disables the resampler for a continuous adjustment of the sample rate. If disabled, the selected sample rate is rounded to a discrete value.

Parameters:
<state> *RST: OFF

Example: BAND:VAR ON

Manual operation: See "[Variable Bandwidth](#)" on page 79

[SENSe<Sensor>:]FREQuency[:CENTer] <frequency>

Sets the carrier frequency of the applied signal. This value is used for frequency response correction of the measurement result.

Parameters:
<frequency> Range: 50e6 to 6e9
 *RST: 1e9
 Default unit: Frequency

Example: FREQ 10000

Manual operation: See "[Frequency](#)" on page 58

[SENSe<Sensor>:]INPut:ATTenuation <attenuation>

Effective if `[SENSe<Sensor>:]INPut:ATTenuation:AUTO OFF` is set.

Sets the input attenuation.

Parameters:
<attenuation> Only two values are possible, 0 dB and 30 dB. The entered value is rounded to the next value.
 Range: 0.0 to 30.0
 *RST: 30.0
 Default unit: dB

Example: INP:ATT 30

Manual operation: See "[<Level>](#)" on page 60

[SENSe<Sensor>:]INPut:ATTenuation:AUTO <att_mode>

Configures the automatic setting of the input attenuation.

It is not possible to enable the result buffer and the automatic input attenuation simultaneously. This combination causes a settings conflict and a static error.

Parameters:

<att_mode>

ON | OFF

ONCE

Adjusts the input attenuation one time, then disables the automatic setting.

*RST: OFF

Example:

INP:ATT:AUTO OFF

Manual operation:

See "[Autoset](#)" on page 57

See "[<State>](#)" on page 59

12.4 Selecting a measurement mode

Web user interface:

- [Chapter 8, "Measurement modes and result displays"](#), on page 61

[SENSe<Sensor>:]FUNction <function>

Sets the measurement mode.

Parameters:

<function>

"POW:ACLR:AVG"

Adjacent channel leakage ratio (ACLR) mode, see [Chapter 8.3, "ACLR mode"](#), on page 70.

"POW:AVG"

Continuous average mode, see [Chapter 8.1, "Continuous average mode"](#), on page 61.

"POW:SERV"

Power servoing mode, see [Chapter 8.6, "Power servoing"](#), on page 80.

Requires the power servoing option (R&S NRQ6-K2).

"POW:SERV:TEST"

Power servoing test mode, see [Chapter 8.6, "Power servoing"](#), on page 80.

Requires the power servoing option (R&S NRQ6-K2).

"XFREQ:POW"

Intermediate frequency (IF) spectrum of the test signal with limited resolution. See [Chapter 8.4, "IF spectrum preview"](#), on page 73.

"XTIME:POW"

Trace mode, see [Chapter 8.2, "Trace mode"](#), on page 66.

"XTime:VOLT:IQ"

I/Q trace mode, see [Chapter 8.5, "I/Q trace mode"](#), on page 73.
Requires the I/Q data interface (R&S NRQ6-K1).

*RST: "POWer:AVG"

Example: FUNC "POWer:AVG"

12.5 Starting and ending a measurement

In a basic continuous measurement, the measurement is started immediately after the continuous measurement mode is enabled. If you want to start the measurement only if a specific condition is fulfilled, for example if a signal level is exceeded or in certain time intervals, define a trigger.

Further information:

- [Chapter 12.9.6, "Configuring the trigger"](#), on page 153
- [Chapter 9.2.1, "Trigger states"](#), on page 88

Web user interface:

- ["To display the Web user interface"](#) on page 35
- [Chapter 6.2, "Measurement procedure in principle"](#), on page 42

Remote commands:

ABORt	128
INITiate:CONTInuous	128
INITiate:ALL	129
INITiate[:IMMEDIATE]	129

ABORt

Immediately interrupts the current measurement.

If the measurement has been started as a single measurement ([INITiate\[:IMMEDIATE\]](#) on page 129), the R&S NRQ6 goes into the idle state.

If a continuous measurement is in progress ([INITiate:CONTInuous](#) on page 128 ON), the R&S NRQ6 waits for triggering and, if the trigger condition is met, starts a new measurement immediately.

See also [Chapter 9.2.1, "Trigger states"](#), on page 88.

Example: ABOR

Usage: Event

INITiate:CONTInuous <state>

Enables or disables the continuous measurement mode. In continuous measurement mode, the R&S NRQ6 does not reach the idle state after a measurement has been completed, but immediately executes another measurement cycle.

If measuring in zero-IF mode (RBW > 40 MHz), consider to zero the power sensor (`CALibration<Channel>:ZERO:AUTO ONCE; *OPC?`).

Parameters:

<state>

See also [Chapter 9.2.1, "Trigger states"](#), on page 88.

ON

Measures continuously. If a measurement is completed, the R&S NRQ6 does not return to idle state but waits for triggering again.

OFF

Ends the continuous measurement mode. The R&S NRQ6 goes into the idle state.

*RST: OFF

Example:

`INIT:CONT OFF`

Manual operation:

See "[Autoset](#)" on page 57

See "[Autoset](#)" on page 64

See "[Autoset](#)" on page 71

INITiate:ALL

INITiate[:IMMediate]

Starts a single measurement cycle. The R&S NRQ6 changes from idle to waiting for trigger and begins the measurement when the trigger condition is fulfilled. Depending on the number of trigger events that are required, e.g. for averaging, the R&S NRQ6 can enter the waiting for trigger state several times. Once the entire measurement is completed, a measurement result is available, and the R&S NRQ6 enters the idle state again.

Use this command only after disabling the continuous measurement mode (see [INITiate:CONTinuous](#) on page 128).

If measuring in zero-IF mode (RBW > 40 MHz), consider to zero the power sensor (`CALibration<Channel>:ZERO:AUTO ONCE; *OPC?`).

See also [Chapter 9.2.1, "Trigger states"](#), on page 88.

Example:

`INIT`

Usage:

Event

Manual operation:

See "[Captured I/Q Samples](#)" on page 80

12.6 Measurement results

- [Results of all kind](#)..... 130
- [Retrieving continuous average results](#)..... 132
- [Retrieving trace results](#)..... 134
- [Retrieving ACLR results](#)..... 135

- [Retrieving IF spectrum results](#)..... 136
- [Retrieving I/Q trace results](#).....136
- [Configuring results](#)..... 136

12.6.1 Results of all kind

If you query measurement data using `FETCh<Sensor>[:SCALar][:POWer][:AVG]?`, the power sensor returns the data of the measurand that was configured before. Generally, this measurand is the average power, but the power sensor can also output data of other measurands. To configure the measurand, use `CALCulate:FEED` before initiating the measurement.

Requirements in trace mode

The power sensor can output data of peak and random values in addition to the average power trace, if the number of measured values, sampled by the output sample rate, is sufficient:

$$N_{\text{measured values}} = \text{trace time} \times \text{output sample rate}$$

The number of measured values has to be at least twice the number of trace points:

$$N_{\text{measured values}} \geq (2 \times N_{\text{trace points}})$$

If the number of measured values falls below, the power sensor can only return the average power trace.

Querying the determining parameters:

- Output sample rate: `[SENSe<Sensor>:]BANDwidth:SRATe:CUV?`
- Trace time: `[SENSe<Sensor>:]TRACe:TIME?`
- $N_{\text{trace points}}$: `[SENSe<Sensor>:]TRACe:POINTs?`

Remote commands:

<code>CALCulate:FEED</code>	130
<code>FETCh<Sensor>[:SCALar][:POWer][:AVG]?</code>	131

`CALCulate:FEED <mode>`

Configures the measurand for which `FETCh<Sensor>[:SCALar][:POWer][:AVG]?` queries the last valid measurement result. Available in continuous average and trace mode.

Parameters:

<mode>

The available measurands depend on the measurement mode selected by `[SENSe<Sensor>:]FUNCTION`.

"POWER:AVERAge" | "POWER:RANDom"

Average value, available in continuous average mode

"POWER:PEAK"

Peak value, available in continuous average mode

"POWER:TRACe"

Measurement sequence, available in trace mode

"POWER:PEAK:TRACe"

Peak value of the samples per trace point, available in trace mode if the number of measured values is sufficient. See ["Requirements in trace mode"](#) on page 130.

"POWER:RANDom:TRACe"

Randomly selected value of the samples per trace point, available in trace mode if the number of measured values is sufficient. See ["Requirements in trace mode"](#) on page 130.

*RST: "POWER:AVERAge"

Example:

The following command sequence configures a peak trace measurement of a pulse-modulated FDD 5G signal with 40 MHz bandwidth and the following parameters: RF = 1 GHz, power level = -30 dBm, pulse period = 200 ms, pulse width = 100 ms.

```
*RST
SENSe:FUNction "XTIME:POWER"
SENSe:FREquency 1.0e9
SENSe:BANDwidth:RESolution:TYPE:AUTO:STATE OFF
SENSe:BANDwidth:RESolution:TYPE FLAT
SENSe:BANDwidth:RESolution 40.0e6
SENSe:TRACe:POINTs 512
SENSe:TRACe:TIME 100e-3
TRIGger:SOURce INTernal
TRIGger:SLOPe POSitive
TRIGger:DTIME 1e-3
TRIGger:HYSteresis 0.1
TRIGger:LEVel -27 dBm
SENSe:TRACe:AVERAge:COUNT 8
SENSe:TRACe:AVERAge:STATE ON
CALCulate:FEED "POWER:PEAK:TRACe"
INITiate
FETCh?
```

Manual operation: See ["Average / Peak / Random"](#) on page 66
See ["Average / Peak / Random"](#) on page 69

FETCh<Sensor>[:SCALar][:POWER][:AVG]?

Queries the last valid measurement result of the measurand that was configured before.

You can configure the following:

- Measurand for continuous average and trace measurements, see [CALCulate:FEED](#).
- Unit, see [UNIT:POWER](#).

Example:	<pre>FETC? Query Results of the continuous average measurement Single scalar value. 2.454005E-05 Results of the trace measurement List of trace points. 2.989667E-12, 3.014341E-12, 2.749163E-12, 2.930418E-12, . . . , 2.698201E-1 Results of the ACLR measurement Channel power list: <TX channel>, <lower adjacent channel>, <upper adjacent channel>, <lower alternate channel>, <upper alternate channel> 6.024564E-09, 4.457427E-12, 4.475155E-12, 4.086455E-12, 4.144877E-12 Results of the I/Q trace measurement Select or query the IQ data format using [SENSe<Sensor>:] TRACe: IQ: DATA: FORMat.</pre>
Usage:	Query only

12.6.2 Retrieving continuous average results

Further information:

- [Chapter 8.1, "Continuous average mode"](#), on page 61

Web user interface:

- [Chapter 8.1.4, "Continuous average result display"](#), on page 65

Remote commands:

`CALCulate:FEED` on page 130

`FETCh<Sensor>[:SCALar] [:POWer] [:AVG]?` on page 131

<code>FETCh<Sensor>:ARRay[:POWer][:AVG]?.....</code>	132
<code>[SENSe<Sensor>:][POWer:][AVG:]BUFFer:CLEAr.....</code>	133
<code>[SENSe<Sensor>:][POWer:][AVG:]BUFFer:COUNT?.....</code>	133
<code>[SENSe<Sensor>:][POWer:][AVG:]BUFFer:DATA?.....</code>	133
<code>[SENSe<Sensor>:][POWer:][AVG:]BUFFer:SIZE.....</code>	133
<code>[SENSe<Sensor>:][POWer:][AVG:]BUFFer:STATe.....</code>	133

`FETCh<Sensor>:ARRay[:POWer][:AVG]?`

Queries the last valid measurement result of a measurement with enabled result buffer.

You can enable the buffer using `[SENSe<Sensor>:] [POWer:] [AVG:]BUFFer:STATe`.

Usage: Query only

[SENSe<Sensor>:][POWer:][AVG:]BUFFer:CLEar

Clears the contents of the result buffer in continuous average mode.

Example: `BUFF:CLE`

Usage: Event

[SENSe<Sensor>:][POWer:][AVG:]BUFFer:COUNt?

Queries the number of results that are currently stored in the result buffer. Available in continuous average mode.

Example: `BUFF:COUN?`

Usage: Query only

[SENSe<Sensor>:][POWer:][AVG:]BUFFer:DATA?

Queries the result buffer and returns the results, even if the buffer is not full. Available in continuous average mode.

In contrast, `FETCH<Sensor>[:SCALar][:POWer][:AVG]?` returns only a valid measurement result, that means only if the buffer is full.

Example: `BUFF:DATA?`

Usage: Query only

[SENSe<Sensor>:][POWer:][AVG:]BUFFer:SIZE <count>

Sets the size of the result buffer in continuous average mode.

You can enable the buffer using `[SENSe<Sensor>:][POWer:][AVG:]BUFFer:STATe`.

Parameters:

<count>	Range:	1 to 131072
	*RST:	1

Example: `BUFF:SIZE 1`

[SENSe<Sensor>:][POWer:][AVG:]BUFFer:STATe <state>

Enables or disables the result buffer in continuous average mode. If enabled, all results generated by trigger events are collected in the buffer until it is full.

It is not possible to enable the result buffer and the automatic input attenuation simultaneously. This combination causes a settings conflict and a static error.

You can set the size of the buffer using `[SENSe<Sensor>:][POWer:][AVG:]BUFFer:SIZE`.

Parameters:`<state> *RST: OFF`**Example:**`BUFF:STAT OFF`

12.6.3 Retrieving trace results

Further information:

- [Chapter 8.2, "Trace mode"](#), on page 66

Web user interface:

- [Chapter 8.2.2, "Trace result display"](#), on page 68

Remote commands:

[CALCulate:FEED](#) on page 130[FETCh<Sensor>\[:SCALar\]\[:POWer\]\[:AVG\]?](#) on page 131[\[SENSe<Sensor>:\]TRACe:DATA?](#)..... 134**[SENSe<Sensor>:]TRACe:DATA?**

Returns the measured trace data in a well-defined format.

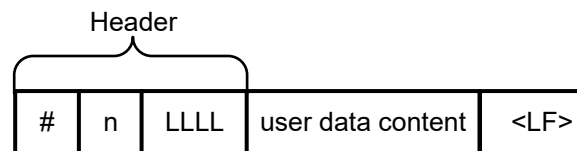
Command responseIn principle, the response has the format as shown in [Figure 12-1](#):**Figure 12-1: Response format**

Header	#	Starting character
	n	Single digit that defines how many of the following digits are interpreted as the size of the content.
	LLLLL	Number consisting of as many digits as specified by "n". This number gives the size of the content.
User data content	See also Figure 12-2 . As many bytes as specified by "LLLLL".	
<LF>	Single linefeed character	

Example

The arbitrary block response data for a user data that contains 45182 bytes is:

`#545182xxxxxx.....xxxxxx <LF>`

The arbitrary block response data for a user data content 'THIS IS A TEST' is:

```
#214THIS IS A TEST<LF>
```

Explanation: 'THIS IS A TEST' has 14 bytes, and '14' has 2 digits, hence the #214

User data content

In the further description, the term "user data content" is used for the totality of the contained measurement results.

In the user data content, there are similar mechanisms as with arbitrary block response data. As indicated above, the user data content can have one or more blocks with trace measurement results, depending on the selection of auxiliary measurands. Each section is composed of:

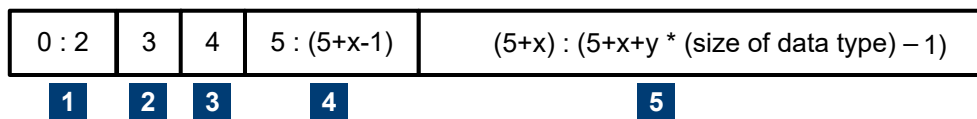

Figure 12-2: User data content format (byte)

1	Result type Always 3 bytes, one for AVG, one for MIN and one for MAX or RND
2	Data type Designator for the contained data type with the size of 1 byte. Currently, the only possible designator is "f" for 4-byte IEEE754 float data type, little endian.
3	Single digit that defines how many of the following digits are interpreted as the number of contained float values.
4	User data length Number consisting of as many digits as specified by (3). This number gives the number of contained float values contained in the user data.
5	User data Measurement result values in the format that is described by the data type. Currently IEEE754 float only.

Usage: Query only

12.6.4 Retrieving ACLR results

Further information:

- [Chapter 8.3, "ACLR mode"](#), on page 70

Web user interface:

- [Chapter 8.3.2, "ACLR result display"](#), on page 71

Remote commands:

`FETCh<Sensor>[:SCALar] [:POWER] [:AVG]?` on page 131

12.6.5 Retrieving IF spectrum results

Further information:

- [Chapter 8.4, "IF spectrum preview"](#), on page 73

Web user interface:

- ["Signal Check"](#) on page 57

Remote commands:

[FETCh<Sensor>\[:SCALar\] \[:POWer\] \[:AVG\]?](#) on page 131

12.6.6 Retrieving I/Q trace results

Further information:

- [Chapter 8.5, "I/Q trace mode"](#), on page 73

Web user interface:

- [Chapter 8.5.3, "I/Q trace parameters"](#), on page 77

Remote commands:

[FETCh<Sensor>\[:SCALar\] \[:POWer\] \[:AVG\]?](#) on page 131

[\[SENSe<Sensor>:\]TRACe:IQ:DATA?](#)..... 136

[SENSe<Sensor>:]TRACe:IQ:DATA?

Effective if [\[SENSe<Sensor>:\]FUNctIon](#) is set to "XTIME:VOLT:IQ".

Queries the IQ trace results. The format of the results is defined by [\[SENSe<Sensor>:\]TRACe:IQ:DATA:FORMat](#).

Alternative command: [FETCh<Sensor>\[:SCALar\] \[:POWer\] \[:AVG\]?](#)

Usage: Query only

Manual operation: See ["Captured I/Q Samples"](#) on page 80

12.6.7 Configuring results

FORMat:BORDER	136
FORMat[:DATA]	137
FORMat:SREGister	137
[SENSe<Sensor>:]TRACe:IQ:DATA:FORMat	138
UNIT:POWer	138

FORMat:BORDER <border>

Selects the order of bytes in 32-bit or 64-bit binary data.

Parameters:

<border> NORMal | SWAPped

NORMal

The 1st byte is the least significant byte, the 4th/8th byte the most significant byte.

Fulfills the Little Endian (little end comes first) convention, used by x86/x64 CPUs, for example.

SWAPped

The 1st byte is the most significant byte, the 4th/8th byte the least significant byte.

Fulfills the Big Endian (big end comes first) convention.

*RST: NORMal

Example: FORM:BORD NORM

FORMat[:DATA] <data[,length]>

Specifies how the R&S NRQ6 sends the numeric data to the controlling host/computer.

Parameters:

<data,length> <REAL,32 | 64>

REAL

Block of binary values, 32-bit or 64-bit each; so-called "SCPI definite length block"

32 | 64

32-bit or 64-bit

If you omit the length, the R&S NRQ6 sets the last used length.

Example for REAL, 32 format:

#6768000....<binary float values>....

Example for REAL, 64 format:

#71536000....<binary float values>....

<data[,length]> <ASCii[,0 to 12]>

ASCii

List of comma-separated, readable values.

[,0 to 12]

Defines the number of decimal places.

The reset value 0 does not restrict the number of decimal places.

Example for ASCii, 4 format:

1.2938e-06, -4.7269e-11, ...

*RST: ASCii,0

Manual operation: See "[Captured I/Q Samples](#)" on page 80

FORMat:SREGister <sregister>

Specifies which format is used for the return value of *STB?.

Parameters:

<register> ASCII | HEXadecimal | OCTal | BINary
 *RST: ASCII

Example:

FORM:SREG ASC

[SENSe<Sensor>:]TRACe:IQ:DATA:FORMat <format>

Defines the format of the I/Q trace results.

Parameters:

<format> COMPatible | IQBLock | IQPair
COMPatible
 512k I data samples, 512k Q data samples, 512k I data ...
IQBLock
 I data block, Q data block
IQPair
 I/Q data sample pairs: I1 Q1 I2 Q2 ...
 *RST: IQPair

Manual operation: See "[Captured I/Q Samples](#)" on page 80

UNIT:POWer <unit>

Sets the output unit for the measured power values.

Parameters:

<unit> DBM | W | DBUV
 *RST: W

Example:

UNIT:POW DBM

Manual operation: See "[dBm / Watt / dBμV](#)" on page 65

12.7 Calibrating and zeroing

Further information:

- [Chapter 9.3.1, "Corrections in the RF path"](#), on page 94
- [Chapter 9.3.2, "Corrections in the IF path"](#), on page 96

Web user interface:

- ["Zero Calibration"](#) on page 99
- ["DC Zeroing"](#) on page 101

The R&S NRQ6 distinguishes between the following calibration data sets:

- User calibration data set
- Factory calibration data set

You can query both calibration data sets, but you can change only the user calibration data set. To do so, you need to prove your authorization by sending `CALibration:UNLock`. Changes of the factory calibration data set are reserved for the Rohde & Schwarz service.

If the factory calibration data is not suitable for your measurement, you can import measurement data files to create your own calibration data set, the so-called user calibration data set. For absolute calibration, you can import two different measurement data files, one for 0 dB attenuation and one for 30 dB attenuation. Proceed as follows:

1. Import a measurement data file:
`CALibration:DATA:PATH<Path>:ABSolute`
 If you import more than one file, the import order does not matter.
2. Start the recalculation of the new calibration data set:
`CALibration:RECalculate`
3. Check the protocol of the new normalized calibration factors:
`CALibration:PROTOCOL?`

An example script for the recalibration of the R&S NRQ6 is provided in R&S NRP Toolkit SDK. In this script, a power measurement is conducted before and after recalibration at a certain frequency, with and without 30 dB attenuation. Thus, the impact of the recalibration on the measurement results is visualized.

You can restore the factory calibration data using `CALibration:RESTore`.

Remote commands:

<code>CALibration:DATA</code>	139
<code>CALibration:DATA:LENGth?</code>	140
<code>CALibration:DATA:PATH<Path>:ABSolute</code>	140
<code>CALibration:FREQUency:LIMits</code>	140
<code>CALibration<Channel>:IQOffset[:AUTO]</code>	141
<code>CALibration:PROTOCOL?</code>	141
<code>CALibration:RECalculate</code>	141
<code>CALibration:RESTore</code>	142
<code>CALibration:SAVE</code>	142
<code>CALibration:UNLock</code>	142
<code>CALibration<Channel>:ZERO:AUTO</code>	142

CALibration:DATA <caldata>

For writing access, you have to prove your authorization, see `CALibration:UNLock`. Reading access is granted without unlocking.

Writes a binary user calibration data set in the memory of the power sensor.

A user calibration data set is generated and used by the power sensor. The factory calibration data set is not affected by this command. To re-use the factory calibration data set, use `CALibration:RESTore`.

Parameters:

<caldata> <block_data>
 Block of binary calibration data, structured in a so-called "SCPI definite length block".

CALibration:DATA:LENGth?

Queries the length in bytes of the calibration data set currently saved in the flash memory. Programs that read out the calibration data set can use this information to determine the capacity of the buffer memory required.

Example: CAL:DATA:LENG?
 Query
 57392
 Response

Usage: Query only

CALibration:DATA:PATH<Path>:ABSolute <blockdata>

For writing access, you have to prove your authorization, see [CALibration:UNLock](#).

Imports a measurement data file for absolute calibration. Two different measurement data files are used, one for 0 dB attenuation and one for 30 dB attenuation.

Absolute accuracy measurement data files are used to recalibrate the absolute accuracy of the R&S NRQ6, the device under test (DUT). At different calibration frequencies, the reference power values (P_{REF}) and the power measured by the R&S NRQ6 (P_{DUT}) are stated. The calibration algorithm adjusts the sensor-internal correction factors (CF) so that P_{DUT} matches P_{REF} afterwards:

$$CF_{new} = (P_{REF} / P_{DUT}) * CF_{old}$$

Suffix:

<Path> 1 to 2
 Attenuation setting; 1 = 0 dB, 2 = 30 dB

Setting parameters:

<blockdata> <block_data>
 An example is given in the programming examples of the R&S NRP Toolkit.

Usage: Setting only

CALibration:FREQuency:LIMits <state>

For writing access, you have to prove your authorization, see [CALibration:UNLock](#). Reading access is granted without unlocking.

Sets the frequency limits for recalibration.

Parameters:

<state> ON | OFF
ON
 Default limits are enabled, see [[SENSe<Sensor>:FREQuency\[:CENTer\]](#)].
OFF
 Lower limit = 0 Hz, upper limit = 2.0E+11 Hz
 *RST: ON

CALibration<Channel>:IQOFset[:AUTO] <state>

Compensates for the internal DC voltage offset. Recommended for measurements in zero-IF mode (RBW > 40 MHz). See also [Chapter 9.3.2.2, "DC zeroing"](#), on page 98.

Suffix:

<Channel> 1 to 4
 Measurement channel if more than one channel is available.

Parameters:

<state> **ONCE | ON**
 Performs DC zeroing once. After completion, zeroing is switched off.
0
 Return value if no zeroing is in progress.
 *RST: OFF

Example:

CAL1:IQOF ONCE
 Performs DC zeroing.

Manual operation: See "[DC Zeroing](#)" on page 101

CALibration:PROTocol?

Reads the protocol containing the normalized calibration factors. The normalization frequency (RefValue) is stated in the measurement data file.

Usage: Query only

CALibration:RECalculate

For writing access, you have to prove your authorization, see [CALibration:UNLock](#).

Recalculates the calibration data set using the imported measurement data file.

If recalculation is successful, the new calibration data set is saved in the flash memory and reloaded for usage.

If recalculation is not successful, the recalibration is terminated.

Tip: The recalculation process takes a few seconds. Use `*OPC` to check when the operation is completed (`CAL:REC; *OPC?`).

Usage: Event

CALibration:REStore

For writing access, you have to prove your authorization, see [CALibration:UNLock](#).

Deletes the user calibration data set and loads the factory calibration data set of the R&S NRQ6.

Usage: Event

CALibration:SAVE

Saves the new calibration data set in the flash memory.

Already included in [CALibration:RECalculate](#), therefore mostly used in calibration tasks reserved for the Rohde & Schwarz service.

Usage: Event

CALibration:UNLock <password>

If you want to use a calibration command that can affect the user calibration data set of the R&S NRQ6, you have to prove your authorization by sending this command first.

Parameters:

```
<password>      1234
                 *RST:      0
```

CALibration<Channel>:ZERO:AUTO <state>

Performs zero calibration. For measurements in zero-IF mode (RBW > 40 MHz), also performs DC zeroing (`CALibration<Channel>:IQOffset[:AUTO] ONCE`). See also [Chapter 9.3.1.2, "Zero calibration"](#), on page 95.

Turn off all test signals before zeroing. An active test signal during zeroing causes an error.

While zero calibration is in progress, no queries or other setting commands are allowed, since the command is synchronous. Any communication attempt can run into a timeout.

After zero calibration, query the static error queue using `SYSTEM:SERRor?`. The following responses are possible:

- 0
No error, zero calibration was successful.
- -240
Warning, zero calibration failed.

Suffix:	
<Channel>	1 to 4 Measurement channel if more than one channel is available.
Parameters:	
<state>	ONCE ON Performs zero calibration once. After completion, zeroing is switched off. 0 Return value if no zeroing is in progress. *RST: OFF
Example:	*CLS CAL1:ZERO:AUTO ONCE Performs zero calibration.
Manual operation:	See " Zero Calibration " on page 99

12.8 Running a selftest

The selftest allows a test of the internal circuitry of the sensor.

Further information:

- [Chapter 15.4, "Performing a selftest"](#), on page 210
- [Chapter 9.3.1, "Corrections in the RF path"](#), on page 94

Web user interface:

- ["Diagnostics - Selftest"](#) on page 111

TEST:SENSor?

Starts a selftest.

Note:

During the selftest, do not apply a signal because this can cause erroneous test results.

In contrast to ***TST?**, this command returns detailed information that you can use for troubleshooting. If one test step or a part of it fails, the overall result is FAIL.

For interpreting the test results, see [Chapter 15.4.1, "Interpreting the test results"](#), on page 211.

Example:	<pre>TEST:SENS? Query "Power Applied: PASS Operating Voltages: PASS Temperatures: PASS Test Generator: Error: Test Generator has no calibration! FAIL LO Level: PASS DC Offset: PASS Displayed Average Noise Level (DANL): PASS Dither: PASS ADC Interface: PASS DDS DAC Interface: PASS " Response</pre>
Usage:	Query only
Manual operation:	See "Diagnostics - Selftest" on page 111

12.9 Configuring measurement settings

This chapter describes the measurement settings for all measurement modes.

Further information:

- [Chapter 8, "Measurement modes and result displays"](#), on page 61
- [Chapter 9, "Measurement configuration"](#), on page 82
- [Chapter 10, "System configuration"](#), on page 107

Contents:

• Configuring a continuous average measurement	144
• Configuring a trace measurement	147
• Configuring an ACLR measurement	151
• Configuring an IF spectrum	151
• Configuring an I/Q trace mode	152
• Configuring the trigger	153
• Configuring the corrections	160
• Configuring the mixer	172
• Configuring the sensor	174

12.9.1 Configuring a continuous average measurement

Further information:

- [Chapter 8.1, "Continuous average mode"](#), on page 61

Web user interface:

- [Chapter 8.1.3, "Continuous average parameters"](#), on page 63

Remote commands:

[SENSe<Sensor>:]AVERage:COUNT	145
[SENSe<Sensor>:]AVERage:RESet	145
[SENSe<Sensor>:]AVERage[:STATe]	145
[SENSe<Sensor>:]AVERage:TCONtrol	146

[SENSe<Sensor>:]AVERAge:TYPE.....	146
[SENSe<Sensor>:]BANDwidth:TYPE.....	146
[SENSe<Sensor>:]CORRection:DCYClE.....	147
[SENSe<Sensor>:]CORRection:DCYClE:STATe.....	147
[SENSe<Sensor>:][[POWer:][AVG:][APERture.....	147

[SENSe<Sensor>:]AVERAge:COUNT <count>

Effective if [SENSe<Sensor>:]AVERAge[:STATe] ON is set.

Sets the number of readings that are averaged for one measured value. The higher the count, the lower the noise, and the longer it takes to obtain a measured value.

Parameters:

<count>	Range:	1 to 65536
	*RST:	1

Example: AVER:COUNT 1

Manual operation: See "<Count>" on page 64

[SENSe<Sensor>:]AVERAge:RESet

Deletes all previous measurement results that the averaging filter contains and initializes the averaging filter. The filter length gradually increases from 1 to the set averaging factor. Thus, trends in the measurement result become quickly apparent. Note that the measurement time required for the averaging filter to settle completely remains unchanged.

Use this command if:

- High averaging factor is set.
[SENSe<Sensor>:]AVERAge:COUNT
- Intermediate values are output as measurement results.
[SENSe<Sensor>:]AVERAge:TCONtrol MOVing
- Power has significantly decreased since the previous measurement, for example by several powers of 10.

In this situation, previous measurement results, which are still contained in the averaging filter, strongly affect the settling of the display. As a result, the advantage of detecting trends in the measurement result while the measurement is still in progress is lost.

Example: AVER:RES

Usage: Event

[SENSe<Sensor>:]AVERAge[:STATe] <state>

Enables or disables the averaging filter.

Parameters:

<state>	*RST:	ON
---------	-------	----

Manual operation: See "<State>" on page 64

[SENSe<Sensor>:]AVERage:TCONtrol <mode>

Defines how the measurement results are output. This is called termination control. See also [Chapter 9.1.1, "Controlling the measurement results"](#), on page 82.

Parameters:

<mode> MOVing | REPeat

MOVing

Outputs intermediate values to facilitate early detection of changes in the measured quantity. In the settled state, that means when the number of measurements specified by the average count has been performed, a moving average is output.

REPeat

Specifies that a measurement result is not output until the entire measurement has been completed. This means that the number of measurement cycle repetitions is equal to the set average count. If the average count is large, the measurement time can be very long.

The average count is set using [\[SENSe<Sensor>:\]AVERage:COUNT](#).

*RST: REPeat

Example: AVER:TCON REP

Manual operation: See ["Moving Average"](#) on page 65

[SENSe<Sensor>:]AVERage:TYPE <type>

Sets the averaging domain. For details, see [Chapter 8.1.1, "Averaging domains"](#), on page 61.

Parameters:

<type> POWER | VIDeo | LINear

*RST: POWER

Example: AVER:TYPE POW

Manual operation: See ["Averaging Domain"](#) on page 64

[SENSe<Sensor>:]BANDwidth:TYPE <type>

Sets how the bandwidth is specified.

Parameters:

<type> RESolution | SRATe

RESolution

By the resolution bandwidth. See [\[SENSe<Sensor>:\]BANDwidth:RESolution](#) on page 124.

SRATe

By the desired sample rate. See [\[SENSe<Sensor>:\]BANDwidth:SRATe](#) on page 125.

*RST: RESolution

Example: BAND:TYPE RES

Manual operation: See "[Specify Bandwidth by](#)" on page 79

[SENSe<Sensor>:]CORRection:DCYClE <duty_cycle>

Sets the duty cycle for measuring pulse-modulated signals. The duty cycle defines the percentage of one period during which the signal is active. If the duty cycle is enabled, the R&S NRQ6 takes this percentage into account when calculating the signal pulse power from the average power.

Parameters:

<duty_cycle> Range: 0.001 to 100.00
 *RST: 1.00
 Default unit: Percent

Example: CORR:DCYC 1

Manual operation: See "[Duty Cycle](#)" on page 65

[SENSe<Sensor>:]CORRection:DCYClE:STATe <state>

Enables or disables the duty cycle correction for the measured value.

Parameters:

<state> *RST: OFF

Example: CORR:DCYC:STAT ON

Manual operation: See "[Duty Cycle](#)" on page 65

[SENSe<Sensor>:] [POWER:] [AVG:] APERtUre <integration_time>

Sets the duration of the sampling window in the continuous average mode. During this time interval, the average signal power is measured.

Parameters:

<integration_time> Range: 8.30E-09 to 30.0
 *RST: 0.02
 Default unit: Seconds

Example: APER 0.02

Manual operation: See "[Aperture Time](#)" on page 65

12.9.2 Configuring a trace measurement

Further information:

- [Chapter 8.2, "Trace mode"](#), on page 66

Web user interface:

- [Chapter 8.2.1, "Trace parameters"](#), on page 66

Remote commands:

[\[SENSe<Sensor>:\]AVERAge:TYPE](#) on page 146

[\[SENSe<Sensor>:\]BANDwidth:TYPE](#) on page 146

[SENSe<Sensor>:]TRACe:AVERAge:COUNT	148
[SENSe<Sensor>:]TRACe:AVERAge[:STATe]	148
[SENSe<Sensor>:]TRACe:AVERAge:TCONtrol	148
[SENSe<Sensor>:]TRACe:OFFSet:TIME	149
[SENSe<Sensor>:]TRACe:RLENgth[:CUV]?	149
[SENSe<Sensor>:]TRACe:POINts	150
[SENSe<Sensor>:]TRACe:TIME	150
[SENSe<Sensor>:]TRACe:TIME:AUTO	150

[SENSe<Sensor>:]TRACe:AVERAge:COUNT <count>

Sets the number of readings that are averaged for one measured value. The higher the count, the lower the noise, and the longer it takes to obtain a measured value.

Averaging is only effective, if [\[SENSe<Sensor>:\]TRACe:AVERAge\[:STATe\]](#) ON is set.

Parameters:

<count> Range: 1 to 65536
 *RST: 1

Manual operation: See "[Autoset](#)" on page 67
 See "[<Count>](#)" on page 67
 See "[Autoset](#)" on page 78

[SENSe<Sensor>:]TRACe:AVERAge[:STATe] <state>

Enables or disables the averaging filter.

Parameters:

<state> *RST: ON

Manual operation: See "[<State>](#)" on page 67

[SENSe<Sensor>:]TRACe:AVERAge:TCONtrol <mode>

Defines how the measurement results are output. This is called termination control. See also [Chapter 9.1.1, "Controlling the measurement results"](#), on page 82.

Parameters:

<mode> MOVing | REPeat

MOVing

Outputs intermediate values to facilitate early detection of changes in the measured quantity. In the settled state, that means when the number of measurements specified by the average count has been performed, a moving average is output.

REPeat

Specifies that a measurement result is not output until the entire measurement has been completed. This means that the number of measurement cycle repetitions is equal to the set average count. If the average count is large, the measurement time can be very long.

The average count is set using `[SENSe<Sensor>:]AVERage:COUNT`.

*RST: REPeat

Example: `TRAC: AVER: TCON REP`

Manual operation: See "[Moving Averaging](#)" on page 68

[SENSe<Sensor>:]TRACe:OFFSet:TIME <time>

Sets the relative position of the trigger event in relation to the trace measurement start:

Trace offset = trace measurement start - trigger delay.

The start of recording relative to the trigger event is set using `TRIGger: DELay`.

Parameters:

<time> Range: -15.0 to 15.0
 *RST: 0.0
 Default unit: Seconds

Example: `TRAC: OFFS: TIME 1.0`

Manual operation: See "[Trace Offset](#)" on page 69

[SENSe<Sensor>:]TRACe:RLEnGth[:CUV]?

The behavior of this query depends on the measurement mode.

- I/Q trace mode (R&S NRQ6-K1)
Queries the number of samples in the current trace.
- Trace mode
Queries the number of real result samples before they are reduced or interpolated to the number of trace points defined by `[SENSe<Sensor>:]TRACe: POINts`. If you want to see the all result samples in the result trace, set the number of trace points to this value.

Usage: Query only

[SENSe<Sensor>:]TRACe:POINts <points>

Sets the number of pixels per trace sequence. In the result display of the web user interface, the maximum resolution is restricted by the number of measured values, sampled by the output sample rate. In remote control, no such restriction applies. If you set more pixels than there are measured values, the R&S NRQ6 duplicates measured values to fill up the gaps.

The query returns the number of samples after the trace has been decimated by the display detector.

Parameters:

<points> Range: 1 to 1048576
 *RST: 1024

Example: TRAC:POIN 1024

[SENSe<Sensor>:]TRACe:TIME <time>

Sets the trace time, the duration of one trace sequence.

Parameters:

<time> The available range depends on the RBW. Even for time settings within range, a static error due to insufficient memory can occur if the output sampling rate is too high. See [Chapter 7.3.3, "Choosing the correct filter type"](#), on page 54.

Range: 8.30E-09 to 30.0
 *RST: 0.01
 Default unit: Seconds

Example: TRAC:TIME 0.01

Manual operation: See ["Time/Div"](#) on page 69

[SENSe<Sensor>:]TRACe:TIME:AUTO <state>

Sets the trace time automatically.

Performs an FFT to calculate the power spectrum and sets the trace time to five times the largest peak of the spectrum, which is a good indication for the dominant period of the signal.

This calculation is performed for any signal without checking the signal-to-noise ratio.

Parameters:

<state> *RST: OFF

Example: TRAC:TIME:AUTO OFF

Manual operation: See ["Autoset"](#) on page 67
 See ["Autoset"](#) on page 78

12.9.3 Configuring an ACLR measurement

Further information:

- [Chapter 8.3, "ACLR mode"](#), on page 70

Web user interface:

- [Chapter 8.3.1, "ACLR parameters"](#), on page 70

Remote commands:

[SENSe<Sensor>:]ACLR:ACHannel:SPACing[:ACHannel]?	151
[SENSe<Sensor>:]ACLR:APERture	151

[SENSe<Sensor>:]ACLR:ACHannel:SPACing[:ACHannel]?

Queries the distance from transmission channel to adjacent channel. The return value depends on the transmission standard selected by the resolution bandwidth setting.

Example:

```
ACLR:ACH:SPAC?
Query
5.000000E+06
Response for 3GPP
```

Usage: Query only

[SENSe<Sensor>:]ACLR:APERture <integration_time>

Sets the duration of the sampling window. During this synchronized time interval, the average signal power is measured on all 5 channels.

Parameters:

```
<integration_time> Range: 1e-3 to 40e-3
*RST: 10e-3
Default unit: Seconds
```

Example: ACLR:APER 0.001

Manual operation: See ["Aperture Time"](#) on page 71

12.9.4 Configuring an IF spectrum

Further information:

- [Chapter 8.4, "IF spectrum preview"](#), on page 73

Remote commands:

[SENSe<Sensor>:]SPECTrum:FFT:FREQuency:STARt?	151
[SENSe<Sensor>:]SPECTrum:FFT:FREQuency:STEP?	152
[SENSe<Sensor>:]SPECTrum:FFT:POINts	152

[SENSe<Sensor>:]SPECTrum:FFT:FREQuency:STARt?

Effective if [\[SENSe<Sensor>:\]FUNction](#) is set to "XFREQ:POW".

Sets the frequency of the first FFT point, and thus the start frequency of the IF spectrum.

Usage: Query only

Manual operation: See "Signal Check" on page 57

[SENSe<Sensor>:]SPECTrum:FFT:FREQuency:STEP?

Effective if [SENSe<Sensor>:]FUNctIon is set to "XFREQ:POW".

Sets the frequency increment between FFT points.

Usage: Query only

Manual operation: See "Signal Check" on page 57

[SENSe<Sensor>:]SPECTrum:FFT:POINTs <points>

Effective if [SENSe<Sensor>:]FUNctIon is set to "XFREQ:POW".

Sets the number of FFT points.

Parameters:

<points>	Range:	32 to 1024
	*RST:	64

Manual operation: See "Signal Check" on page 57

12.9.5 Configuring an I/Q trace mode

Requires the I/Q data interface (R&S NRQ6-K1).

Further information:

- [Chapter 8.5, "I/Q trace mode"](#), on page 73

Web user interface:

- [Chapter 8.5.3, "I/Q trace parameters"](#), on page 77

Remote commands:

[SENSe<Sensor>:]BANDwidth:TYPE on page 146

[SENSe<Sensor>:]TRACe:IQ:RENgth..... 152

[SENSe<Sensor>:]TRACe:SRATe[:CUV]?..... 153

[SENSe<Sensor>:]TRACe:IQ:SYNC:TYPE..... 153

[SENSe<Sensor>:]TRACe:IQ:RENgth <value>

Requires the I/Q data interface (R&S NRQ6-K1).

Sets the number of result samples.

Parameters:

<value> Range: 1 to 15000000
 *RST: 1024

Example: TRAC:IQ:RLEN 2000

Manual operation: See "[Result Length](#)" on page 78

[SENSe<Sensor>:]TRACe:SRATe[:CUV]?

See [\[SENSe<Sensor>:\]BANDwidth:SRATe:CUV?](#) on page 126.

Usage: Query only

[SENSe<Sensor>:]TRACe:IQ:SYNC:TYPE <type>

Requires the following options:

- I/Q data interface (R&S NRQ6-K1)
- phase coherent measurements (R&S NRQ6-K3)

Sets the synchronization for phase coherent measurements. The sender is synchronized to the signal source by external reference and triggers the receiver. Select the output port for the trigger signal using [TRIGger:SENDER:PORT](#) on page 158.

See also [Chapter 9.2.6, "Trigger sender usage"](#), on page 90.

Parameters:

<type> OFF | SENDER | RECEIVER
 *RST: OFF

Example: TRACe:IQ:SYNC:TYPE SEND
 Configures the R&S NRQ6 as sender.

Manual operation: See "[Sync Mode](#)" on page 79

12.9.6 Configuring the trigger

Further information:

- [Chapter 9.2.1, "Trigger states"](#), on page 88
- [Chapter 12.9, "Configuring measurement settings"](#), on page 144

Web user interface:

- [Chapter 9.2.7, "Trigger parameters"](#), on page 91

Remote commands:

TRIGger:ATRigger:DElay	154
TRIGger:ATRigger:EXECuted?	154
TRIGger:ATRigger[:STATE]	154
TRIGger:COUNT	155
TRIGger:DElay	155
TRIGger:DTIME	155

TRIGger:EXTeRnal<2...2>:IMPedance.....	155
TRIGger:HOLDoff.....	156
TRIGger:HYSTeresis.....	156
TRIGger:IMMediate.....	156
TRIGger:JITTer?.....	157
TRIGger:JITTer:METhod.....	157
TRIGger:JITTer:METhod:CUV?.....	157
TRIGger:LEVel.....	158
TRIGger:LEVel:AUTO.....	158
TRIGger:LEVel:UNIT.....	158
TRIGger:SENDER:PORT.....	158
TRIGger:SENDER:STATe.....	159
TRIGger:SLOPe.....	159
TRIGger:SOURce.....	159
TRIGger:SYNC:PORT.....	160
TRIGger:SYNC:STATe.....	160

TRIGger:ATRigger:DElay <delay>

Effective only if [TRIGger:ATRigger\[:STATe\]](#) on page 154 is set to ON.

Sets the delay between the artificial trigger event and the beginning of the actual measurement

Parameters:

<delay>	Range:	0.1 to 5.0
	*RST:	0.3
	Default unit:	Seconds

TRIGger:ATRigger:EXECuted?

Queries the number of measurements that were triggered automatically since [TRIGger:ATRigger\[:STATe\]](#) on page 154 was set to ON.

In normal scalar measurements, this number can only be 0 or 1. If a buffered measurement was executed, this number indicates how many results in the returned array of measurement data were executed without a real trigger event.

Usage: Query only

TRIGger:ATRigger[:STATe] <state>

Controls the automatic trigger function. If enabled, an artificial trigger is generated if the delay time has elapsed after the measurement start and no trigger event has occurred. The delay time is set using [TRIGger:ATRigger:DElay](#) on page 154.

The command is only effective in the trace mode and, irrespective of the set averaging factor, only one trace is recorded.

Parameters:

<state>	*RST:	OFF
---------	-------	-----

Manual operation: See "Autoset" on page 67
See "Autoset" on page 78

TRIGger:COUNT <count>

Sets the number of measurement cycles to be performed when the measurement is started using `INITiate[:IMMEDIATE]` on page 129.

This number equals the number of results that can be obtained from the sensor after a single measurement. As long as the defined number of measurements is not executed, the sensor automatically initiates another measurement internally when the current result is available.

This command is particularly useful in conjunction with buffered measurements. For example, to fill a buffer with a predefined size with measurements that have been triggered externally or by `*TRG` without having to start the measurement multiple times.

Parameters:

<count> Range: 1 to 131072
 *RST: 1

TRIGger:DElay <delay>

Sets the delay between the trigger event and the beginning of the actual measurement (integration).

Parameters:

<delay> Range: -5.0 to 10.0
 *RST: 0.0
 Default unit: Seconds

Manual operation: See "Trigger Delay" on page 92

TRIGger:DTIME <dropout_time>

Sets the dropout time for the internal trigger source. During this time, the signal power must exceed (negative trigger slope) or undercut (positive trigger slope) the level defined by the trigger level and trigger hysteresis. At least, this time must elapse before triggering can occur again.

See [Chapter 9.2.3, "Dropout time"](#), on page 89.

Parameters:

<dropout_time> Range: 0.00 to 10.00
 *RST: 0.00
 Default unit: Seconds

Manual operation: See "Trigger Dropout" on page 93

TRIGger:EXtErnal<2...2>:IMPedance <impedance>

Effective only if `TRIGger:SOURce EXtErnal2` is set.

Sets termination resistance of the second external trigger input. Choose the setting that fits the impedance of the trigger source to minimize reflections on the trigger signals.

Suffix:

<2...2> 2...2

Parameters:

<impedance> HIGH | LOW
 HIGH
 ~10 kΩ
 LOW
 50 Ω
 *RST: HIGH

Manual operation: See "[Trigger 2 I/O Impedance](#)" on page 93

TRIGger:HOLDoff <holdoff>

Sets the hold-off time, a period after a trigger event during which all trigger events are ignored.

See [Chapter 9.2.4, "Hold-off time"](#), on page 90.

Parameters:

<holdoff> Range: 0.00 to 10.00
 *RST: 0.00
 Default unit: Seconds

Manual operation: See "[Trigger Holdoff](#)" on page 93

TRIGger:HYSTeresis <hysteresis>

Sets the hysteresis. A trigger event occurs, if the trigger level:

- Falls below the set value on a rising slope.
- Rises above the set value on a falling slope.

Thus, you can use this setting to eliminate the effects of noise in the signal for the edge detector of the trigger system.

Parameters:

<hysteresis> Range: 0.00 to 10.00
 *RST: 0.00
 Default unit: DB

Manual operation: See "[Trigger Hysteresis](#)" on page 93

TRIGger:IMMediate

Causes a generic trigger event. The R&S NRQ6 leaves the waiting for trigger state immediately, irrespective of the trigger source and the trigger delay, and starts the measurement.

This command is the only way to start a measurement if the trigger source is set to hold (`TRIGger:SOURce HOLD`). Only one measurement cycle is executed, irrespective of the averaging factor.

Usage: Event

TRIGger:JITTer?

Available in trace mode.

Queries the known trigger offset.

Example:

```
TRIG:JITT?
Query
0.000000E+00
Result
```

Usage: Query only

TRIGger:JITTer:METHod <methode>

Available in trace mode.

Defines the method how to cope with the misalignment between the trigger event and the sample point.

Parameters:

<methode> COMPensate | MEASure | NONE

COMPensate | MEASure

See [Chapter 9.2.5, "Trigger jitter"](#), on page 90.

NONE

Neither measures nor corrects or compensates the trigger jitter.

*RST: COMPensate

Example: TRIG:JITT:METHOD COMP

Manual operation: See ["Jitter Suppression"](#) on page 92

TRIGger:JITTer:METHod:CUV?

Available in trace mode.

Queries the currently used value.

Example:

```
TRIG:JITT:METHOD:CUV?
Query
NONE
Result
```

Usage: Query only

TRIGger:LEVel <level>

Effective only if **TRIGger:SOURce** is set to **INTernal**.

Sets the trigger threshold for internal triggering.

If you enter a value without unit, the unit is defined by **TRIGger:LEVel:UNIT**.

Parameters:

<level> If **[SENSe<Sensor>:]INPut:ATTenuation** is set to 0 dB, the trigger level is restricted to $\leq 100 \mu\text{W}$. Values $> 100 \mu\text{W}$ cause a static error.

 If no offset is set (**[SENSe<Sensor>:]CORRection:OFFSet**) and enabled (**[SENSe<Sensor>:]CORRection:OFFSet:STATe ON**), the following range applies.

 Range: 1e-13 to 0.1

 *RST: 1.0e-9

 Default unit: Watts

Manual operation: See "[Trigger Level](#)" on page 92

TRIGger:LEVel:AUTO <val>

Sets the trigger level automatically. Performs a measurement and uses the mean value between the maximum and minimum sample of the trace that has not been decimated by the display detector.

Parameters:

<val> *RST: OFF

Example: **TRIG:LEV:AUTO OFF**

Manual operation: See "[Autoset](#)" on page 67
 See "[Autoset](#)" on page 78
 See "[Trigger Level](#)" on page 92

TRIGger:LEVel:UNIT <unit>

Sets the unit of the trigger level if this value is entered without a unit.

See also **TRIGger:LEVel** on page 158.

Parameters:

<unit> DBM | W | DBUV

 *RST: W

TRIGger:SENDER:PORT <sender_port>

Effective only if the R&S NRQ6 is trigger sender:

- **TRIGger:SENDER:STATe ON**
- **[SENSe<Sensor>:]TRACe:IQ:SYNC:TYPE SEND**

Selects the port where the R&S NRQ6 outputs a digital trigger signal. See [Chapter 9.2.6, "Trigger sender usage"](#), on page 90.

Parameters:

<sender_port> EXT1 | EXTERNAL1 | EXT2 | EXTERNAL2
 *RST: EXT1

Example:

```
TRIG:SEND:PORT EXT1
TRIG:SOUR EXT2
TRIG:SEND:STAT ON
```

Example:

```
TRIG:SEND:PORT EXT2
TRIG:SOUR EXT1
TRIG:SEND:STAT ON
```

Manual operation: See ["Sender Port"](#) on page 93

TRIGger:SENDER:STATE <state>

Enables or disables the trigger sender state. See [Chapter 9.2.6, "Trigger sender usage"](#), on page 90.

If enabled, select the output port for the trigger signal using `TRIGger:SENDER:PORT` on page 158.

Parameters:

<state> *RST: OFF

Example:

```
TRIG:SEND:STAT ON
```

Manual operation: See ["Sender State"](#) on page 94

TRIGger:SLOPE <slope>

Effective only if `TRIGger:SOURce` is set to `INTERNAL` or `EXTERNAL`.

Determines which edge of the envelope power, with internal triggering, or increasing voltage, with external triggering, is used for triggering.

Parameters:

<slope> POSitive | NEGative
POSitive
 Rising edge
NEGative
 Falling edge
 *RST: POSitive

TRIGger:SOURce <source>

Selects the source for the trigger event.

Parameters:

<source> HOLD | IMMEDIATE | INTERNAL | BUS | EXTERNAL | EXT1 |
EXTERNAL1 | EXT2 | EXTERNAL2

See [Chapter 9.2.2, "Trigger sources"](#), on page 88.

*RST: IMMEDIATE

Example:

TRIG:SOUR IMM

Manual operation:

See ["Autoset"](#) on page 64

See ["Autoset"](#) on page 67

See ["Autoset"](#) on page 71

See ["Autoset"](#) on page 78

See ["Trigger Source"](#) on page 92

TRIGger:SYNC:PORT <sync_port>

Selects the external connection for the sync output of the sensor. For more information, see [TRIGger:SYNC:STATe](#) on page 160.

Parameters:

<sync_port> EXT1 | EXTERNAL1 | EXT2 | EXTERNAL2

*RST: EXT1

TRIGger:SYNC:STATe <state>

Usually used if [TRIGger:SENDER:STATe](#) is set to ON.

If enabled, blocks the external trigger bus as long as the sensor remains in the measurement state. Thus, ensures that a new measurement is only started after all sensors have completed their measurements.

Make sure that the number of repetitions is the same for all the sensors involved in the measurement. Otherwise, the trigger bus is blocked by any sensor that has completed its measurements before the others and has returned to the idle state.

See also [Chapter 9.2.1, "Trigger states"](#), on page 88.

Parameters:

<state> *RST: OFF

Manual operation: See ["Sync. State"](#) on page 94

12.9.7 Configuring the corrections

Further information:

- [Chapter 9.3, "Correction settings"](#), on page 94
- [Chapter 12.7, "Calibrating and zeroing"](#), on page 138
- [Chapter 12.9, "Configuring measurement settings"](#), on page 144

12.9.7.1 Offset corrections

Further information:

- [Chapter 9.3.1.3, "Accounting for external losses"](#), on page 96

Web user interface:

- [Chapter 9.3.3, "Correction parameters"](#), on page 99

Remote commands:

[SENSe<Sensor>:]CORRection:OFFSet	161
[SENSe<Sensor>:]CORRection:OFFSet:STATe	161

[SENSe<Sensor>:]CORRection:OFFSet <offset>

Sets a fixed offset that is added to the measured value to account for external attenuation or amplification.

Parameters:

<offset> Range: -200.0 to 200.0
 *RST: 0
 Default unit: dB

Example: CORR:OFFS 0

Manual operation: See "[<Value>](#)" on page 100

[SENSe<Sensor>:]CORRection:OFFSet:STATe <state>

Enables or disables the offset correction.

Parameters:

<state> *RST: OFF

Example: CORR:OFFS:STAT ON

Manual operation: See "[<State>](#)" on page 100

12.9.7.2 DC rejection

Further information:

- [Chapter 9.3.2.1, "DC rejection"](#), on page 96

Web user interface:

- [Chapter 9.3.3, "Correction parameters"](#), on page 99

Remote commands:

[SENSe<Sensor>:]FILTer:DCReject:FCORner	162
[SENSe<Sensor>:]FILTer:DCReject:FCORner:CUV?	162
[SENSe<Sensor>:]FILTer:DCReject[:]STATe]	162

[SENSe<Sensor>:]FILTer:DCReject:FCORner <frequency>

Sets the corner (cut-off) frequency of the DC reject filter.

Parameters:

<frequency> Range: 146.0 to 12.5e6
 *RST: 1166.0
 Default unit: Frequency

Manual operation: See "[Desired 3dB Frequency](#)" on page 101

[SENSe<Sensor>:]FILTer:DCReject:FCORner:CUV?

Queries the currently used corner frequency of the DC reject filter.

Usage: Query only

Manual operation: See "[Used 3dB Frequency](#)" on page 101

[SENSe<Sensor>:]FILTer:DCReject[:STATe] <state>

Available for resolution bandwidths > 40 MHz (zero-IF mode).

Enables or disables the DC reject filter. Set the corner (cut-off) frequency points using [\[SENSe<Sensor>:\]FILTer:DCReject:FCORner](#).

Parameters:

<state> *RST: OFF

Manual operation: See "<State>" on page 101

12.9.7.3 Noise correction

Further information:

- [Chapter 9.3.1.1, "Noise correction"](#), on page 95

Web user interface:

- [Chapter 9.3.3, "Correction parameters"](#), on page 99

Remote commands:

[SENSe<Sensor>:]POWER:NCORrection[:STATe] <state>

Enables or disables the noise cancellation.

Parameters:

<state> *RST: OFF

Example: POW:NCOR OFF

Manual operation: See "[Noise Correction](#)" on page 100

12.9.7.4 S-parameter corrections

S-parameter correction compensates for the losses and reflections introduced by a component — such as an attenuator, directional coupler, or matching pad — that is attached to a power sensor. Using S-parameters instead of a fixed offset increases measurement accuracy by accounting for the interaction between the power sensor and the component. It shifts the reference plane of the power sensor from its RF connector to the input of the device that is being applied externally.

The R&S NRQ6 allows compensating for the influence of any 2-port device between the signal source and the power sensor input. As a result, the firmware can calculate the power that the signal source actually delivers. Examples of such 2-port devices include attenuators, matching pads, minimum-loss pads and waveguide adapters. One precondition for such compensation is that you provide a complete set of S-parameter data for the 2-port device in the frequency range required by the application.

Configuring S-parameters

On delivery from the factory, the R&S NRQ6 comes without any S-parameter data set.

There are two ranges for S-parameter data sets. Use them depending on the purpose of the S-parameter data set:

- 1 to 5: factory S-parameter data set
Retained if the power sensor is sanitized.
You cannot add, modify or delete the factory S-parameter data sets. Changes are reserved for the Rohde & Schwarz service.
- 1001 to 1020: user S-parameter data set
Deleted if the power sensor is sanitized.
You can add, modify or delete the user S-parameter data sets.

To create an S-parameter data set

1. Load the S-parameter data set.
`[SENSe<Sensor>:]CORRection:SPDevice<Device>:DATA`
2. Define a name of the data set (optional).
`[SENSe<Sensor>:]CORRection:SPDevice<Device>:MNEMonic`
3. Define a minimum power (optional).
`[SENSe<Sensor>:]CORRection:SPDevice<Device>:MINPower`
4. Define a maximum power (optional).
`[SENSe<Sensor>:]CORRection:SPDevice<Device>:MAXPower`

Block data example

```
#3874
# HZ S RI R 50
10000000 -0.00964501 0.0013 0.315341 -0.0236 0.315341 -0.0236 -0.00980809 0.000733
11000000 -0.009641379 0.001308 0.3153168 -0.0238 0.3153168 -0.0238 -0.009802621 0.0007389
12000000 -0.009637748 0.001316 0.3152926 -0.024 0.3152926 -0.024 -0.009797152 0.0007448
13000000 -0.009634117 0.001324 0.3152684 -0.0242 0.3152684 -0.0242 -0.009791683 0.0007507
14000000 -0.009630486 0.001332 0.3152442 -0.0244 0.3152442 -0.0244 -0.009786214 0.0007566
17997000000 -0.07257106 -0.06043665 0.08342979 0.3035512 0.08342979 0.3035512 -0.01876237 0.0529304
17998000000 -0.07260944 -0.0604 0.08363566 0.3034908 0.08363566 0.3034908 -0.01872828 0.0529443
17999000000 -0.07264782 -0.06036335 0.08384153 0.3034304 0.08384153 0.3034304 -0.01869419 0.0529582
18000000000 -0.0726862 -0.0603267 0.0840474 0.30337 0.0840474 0.30337 -0.0186601 0.0529721
```



You can query the values of an S-parameter set, but for editing or deleting, you need to prove your authorization by sending `[SENSe<Sensor>:]CORRection:SPDevice<Device>:UNLock` for the S-parameter data set.

To query existing S-parameter data sets

► `[SENSe<Sensor>:]CORRection:SPDevice<undef>:LIST?`

To use the S-parameter correction

1. Select an S-parameter data set.
`[SENSe<Sensor>:]CORRection:SPDevice<undef>:SElect`
2. Enable the S-parameter correction.
`[SENSe<Sensor>:]CORRection:SPDevice<undef>:STATe`

Remote commands:

```
[SENSe<Sensor>:]CORRection:SPDevice<Device>:DATA..... 164
[SENSe<Sensor>:]CORRection:SPDevice<Device>:MAXPower..... 165
[SENSe<Sensor>:]CORRection:SPDevice<Device>:MINPower..... 165
[SENSe<Sensor>:]CORRection:SPDevice<Device>:MNEMonic..... 166
[SENSe<Sensor>:]CORRection:SPDevice<Device>:UNLock..... 166
[SENSe<Sensor>:]CORRection:SPDevice<undef>:DELete..... 167
[SENSe<Sensor>:]CORRection:SPDevice<undef>:LIST?..... 167
[SENSe<Sensor>:]CORRection:SPDevice<undef>:SElect..... 167
[SENSe<Sensor>:]CORRection:SPDevice<undef>:STATe..... 168
```

[SENSe<Sensor>:]CORRection:SPDevice<Device>:DATA <blockdata>

For writing access, you have to prove your authorization, see `[SENSe<Sensor>:]CORRection:SPDevice<Device>:UNLock`. Reading access is granted without unlocking.

Downloads the S-parameter data to the power sensor and assigns the suffix to the corresponding S-parameter device.

The R&S NRQ6 uses these data directly or interpolates for values that are not listed.

Suffix:

<Device> 1 to 5, 1001 to 1020
S-parameter data set

Parameters:

<blockdata> <block_data>
Definite length-arbitrary block data containing the direct copy of the *.s2p file in the following format:

Single digit indicating how many digits follow to specify the size of the file.
Number that specifies the size of the file.
Option line that describes the data format; in the example "# HZ S RI R 50".
Data
0x0a as appended delimiter for line feed

Example: See "[Block data example](#)" on page 164.

[SENSe<Sensor>:]CORRection:SPDevice<Device>:MAXPower <maxpower>

For writing access, you have to prove your authorization, see [\[SENSe<Sensor>:\]CORRection:SPDevice<Device>:UNLock](#). Reading access is granted without unlocking.

Sets the maximum power for the power sensor with the S-parameter device attached to it.

Suffix:

<Device> 1 to 5, 1001 to 1020
S-parameter data set

Parameters:

<maxpower> Optional setting. If no value is set, the query returns NaN.
Range: 0 to 1.0e6
*RST: 0
Default unit: Watts

Example: CORR:SPD1014:MAXP 1

[SENSe<Sensor>:]CORRection:SPDevice<Device>:MINPower <minpower>

For writing access, you have to prove your authorization, see [\[SENSe<Sensor>:\]CORRection:SPDevice<Device>:UNLock](#). Reading access is granted without unlocking.

Sets the minimum power for the power sensor with the S-parameter device attached to it.

Use [SYSTEM:MINPower?](#) to query the minimum power of the overall system.

Suffix:

<Device> 1 to 5, 1001 to 1020
S-parameter data set

Parameters:

<minpower> Optional setting. If no value is set, the query returns NaN.
Range: 0 to 1.0e6
*RST: 0
Default unit: Watts

Example: CORR:SPD5:MINP 1e-17

[SENSe<Sensor>:]CORRection:SPDevice<Device>:MNEMonic <mnemonic>

For writing access, you have to prove your authorization, see [\[SENSe<Sensor>:\]CORRection:SPDevice<Device>:UNLock](#). Reading access is granted without unlocking.

Sets the name of an S-parameter data set. If no name is provided, "not available" is used as name.

Suffix:

<Device> 1 to 5, 1001 to 1020
S-parameter data set

Parameters:

<mnemonic> Name consisting of max. 100 characters

Example: CORR:SPD2:MNEM "3dB attenuation"

[SENSe<Sensor>:]CORRection:SPDevice<Device>:UNLock <password>

If you want to add, edit or delete a data set of an S-parameter device, you have to prove your authorization by sending this command first.

Suffix:

<Device> 1 to 5, 1001 to 1020
S-parameter data set

Parameters:

<password> 1234
*RST: 0

Example: CORR:SPD3:UNL 1234
Unlocks S-parameter data set 3.

Example: CORR:SPD1001:UNL 0
Locks S-parameter data set 1001.

[SENSe<Sensor>:]CORRection:SPDevice<undef>:DELeTe <num>

For writing access, you have to prove your authorization, see [\[SENSe<Sensor>:\]CORRection:SPDevice<Device>:UNLock](#). Reading access is granted without unlocking.

Deletes the data set of the selected S-parameter device.

Suffix:

<undef> 1
No suffix required.

Parameters:

<num> Range: 1 to 5, 1001 to 1020
*RST: 1

Example:

CORR:SPD:DEL 2
Deletes S-parameter data set 2.

[SENSe<Sensor>:]CORRection:SPDevice<undef>:LIST?

Queries the list of the S-parameter data sets that have been downloaded to the power sensor. Returns the consecutive number and mnemonic of each data set, separated by linefeeds.

Suffix:

<undef> 1
No suffix required.

Example:

CORR:SPD:LIST?
"1:3dB attenuation
2:10dB attenuation
1014:20dB attenuation"

Usage:

Query only

[SENSe<Sensor>:]CORRection:SPDevice<undef>:SELEct <num>

Selects a downloaded data set for S-parameter correction.

Suffix:

<undef> 1
No suffix required.

Parameters:

<num> Range: 1 to 5, 1001 to 1020
*RST: 1

Example:

CORR:SPD:SEL 2

[SENSe<Sensor>:]CORRection:SPDevice<undef>:STATe <state>

Enables or disables the S-parameter correction. If enabled, uses the S-parameter data set selected by [SENSe<Sensor>:]CORRection:SPDevice<undef>:SElect.

Suffix:

<undef> 1
No suffix required.

Parameters:

<state> *RST: OFF

Example:

CORR:SPD:STAT ON
Enables the selected S-parameter data set.

Configuring the power sensor behavior

You can configure the power sensor behavior regarding S-parameter corrections. There are three parameters to control the behavior:

- **CORRdef**
If enabled, the S-parameter correction is enabled automatically when the R&S NRQ6 is started. The selected device, for which the S-parameter correction is enabled, is the default device. Select the default device using [SENSe<Sensor>:]CORRection:SPDevice<undef>:INDEX:DEFault.
- **SElectlock**
If enabled, the selection of an S-parameter device is locked and cannot be changed using [SENSe<Sensor>:]CORRection:SPDevice<undef>:SElect or the R&S NRX base unit.
- **STATelock**
If enabled, the state that is selected by [SENSe<Sensor>:]CORRection:SPDevice<undef>:SElect is locked and cannot be changed by using [SENSe<Sensor>:]CORRection:SPDevice<undef>:STATe or the R&S NRX base unit.

Remote commands:

[SENSe<Sensor>:]CORRection:SPDevice<undef>:CLEar.....	168
[SENSe<Sensor>:]CORRection:SPDevice<undef>:FLAGs?.....	169
[SENSe<Sensor>:]CORRection:SPDevice<undef>:INDEX:DEFault.....	169
[SENSe<Sensor>:]CORRection:SPDevice<undef>:SET.....	169

[SENSe<Sensor>:]CORRection:SPDevice<undef>:CLEar <state>

Disables the selected parameter.

Suffix:

<undef> 1
No suffix required.

Setting parameters:

<state> CORRdef | STATelock | SElectlock

These parameters control the power sensor behavior regarding S-parameter corrections. See "[Configuring the power sensor behavior](#)" on page 168.

*RST: CORRdef

Example:

CORR:SPD:CLE STAT

Usage:

Setting only

[SENSe<Sensor>:]CORRection:SPDevice<undef>:FLAGs?

Queries which parameters controlling the power sensor behavior regarding S-parameter corrections are enabled.

Suffix:

<undef> 1
No suffix required.

Example:

CORR:SPD:FLAG?
CORR, STAT, SEL

All three parameters are enabled. See also "[Configuring the power sensor behavior](#)" on page 168.

Usage:

Query only

[SENSe<Sensor>:]CORRection:SPDevice<undef>:INDEX:DEFault <num>

Sets the S-parameter device that is used if the S-parameter correction is enabled automatically when the R&S NRQ6 is started (`[SENSe<Sensor>:]CORRection:SPDevice<undef>:SET CORRdef`).

Suffix:

<undef> 1
No suffix required.

Parameters:

<num> 0 means that no default S-parameter device is selected. In consequence, the S-parameter correction is not enabled automatically when the R&S NRQ6 is started.
If the selected default S-parameter device is deleted, 0 is set automatically.

Range: 1 to 5, 1001 to 1020

*RST: Reset has no effect

Example:

CORR:SPD:IND:DEF 1

[SENSe<Sensor>:]CORRection:SPDevice<undef>:SET <state>

Enables the selected parameter.

Suffix:

<undef> 1
No suffix required.

Setting parameters:

<state> CORRdef | STATelock | SElectlock

These parameters control the power sensor behavior regarding S-parameter corrections. See "[Configuring the power sensor behavior](#)" on page 168.

*RST: CORRdef

Example:

CORR:SPD:SET STAT

Usage:

Setting only

12.9.7.5 S-gamma corrections

Using the complex reflection coefficient, you can determine the power P delivered by the signal source with considerably greater accuracy.

The coefficient of the signal source Γ_{source} is defined by its magnitude and phase:

- [SENSe<Sensor>:] SGAMma:MAGNitude
- [SENSe<Sensor>:] SGAMma:PHASe

The complex reflection coefficient Γ_{sensor} of the power sensor, which is also required for the correction, is prestored in the calibration data memory for many frequencies.

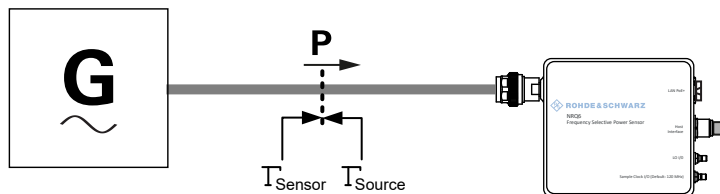

Figure 12-3: Correction of interactions between the power sensor and the signal source

If the gamma correction is performed in combination with an S-parameter correction ([SENSe<Sensor>:] CORRection:SPDevice<undef>:STATe ON), the following is considered:

- Interaction of the signal source with the S-parameter device
- Input of the power sensor, depending on the transmission, expressed by the term $S_{12}S_{21}$

The interaction between the complex reflection coefficient Γ_{sensor} of the power sensor and the reflection of port 2 is expressed by s_{22} , see [Figure 12-4](#). If the S-parameter correction is enabled, this interaction is always considered, regardless whether gamma correction is performed or not.

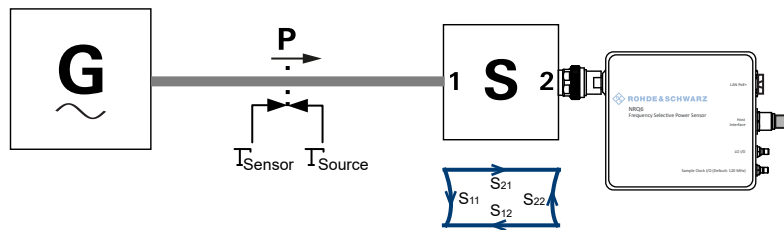

Figure 12-4: Correction of interactions between the power sensor, the signal source, and the S-parameter device

Remote commands:

[SENSe<Sensor>:]SGAMma:CORRection:STATe.....	171
[SENSe<Sensor>:]SGAMma:MAGNitude.....	171
[SENSe<Sensor>:]SGAMma:PHASe.....	171

[SENSe<Sensor>:]SGAMma:CORRection:STATe <state>

Enables or disables the use of the complex reflection coefficient to correct the interactions of power sensor and signal source.

Parameters:

<state> *RST: OFF

Manual operation: See "<State>" on page 100

[SENSe<Sensor>:]SGAMma:MAGNitude <magnitude>

Sets the magnitude of the complex reflection coefficient of the source, Γ_{source} .

Parameters:

<magnitude> 0.0 \triangleq ideal matched source
 1.0 \triangleq total reflection
 Range: 0.0 to 1.0
 *RST: 0.0

Example: SGAM:MAGN 0

Manual operation: See "Magnitude" on page 100

[SENSe<Sensor>:]SGAMma:PHASe <phase>

Sets the phase angle of the complex reflection coefficient of the source, Γ_{source} .

Parameters:

<phase> Range: -360.0 to 360.0
 *RST: 0.0

Example: SGAM:PHAS 0

Manual operation: See "Phase" on page 100

12.9.8 Configuring the mixer

Further information:

- [Chapter 12.9, "Configuring measurement settings"](#), on page 144

Web user interface:

- [Chapter 9.4, "Mixer settings"](#), on page 101

Remote commands:

[SENSe<Sensor>:]FREQUency:CONVersion:MIXer:IF[:CUV]?.....	172
[SENSe<Sensor>:]FREQUency:CONVersion:MIXer:IF:SIDeband.....	172
[SENSe<Sensor>:]FREQUency:CONVersion:MIXer:IF:SIDeband:AUTO[:STATe].....	172
[SENSe<Sensor>:]FREQUency:CONVersion:MIXer:LO[:CUV]?.....	173
[SENSe<Sensor>:]FREQUency:CONVersion:MIXer:LO:OUTPut[:STATe].....	173
[SENSe<Sensor>:]FREQUency:CONVersion:MIXer:LO:SOURce.....	173
[SENSe<Sensor>:]FREQUency:TRACk.....	174
[SENSe<Sensor>:]FREQUency:TRACk:CUV[:STATe]?.....	174
[SENSe<Sensor>:]FREQUency:TRACk:FREQUency?.....	174

[SENSe<Sensor>:]FREQUency:CONVersion:MIXer:IF[:CUV]?

Queries the currently used intermediate frequency.

Example:

```
FREQ:IF?
Query
-2.500000E+07
Result in Hz
```

Usage: Query only

Manual operation: See "[Frequency \(IF\) - Frequency](#)" on page 104

[SENSe<Sensor>:]FREQUency:CONVersion:MIXer:IF:SIDeband <select>

Sets the currently used intermediate frequency sideband.

Parameters:

```
<select>      LEFT | RIGHT
*RST:        LEFT
```

Example:

```
FREQ:CONV:MIX:IF:SID RIGH
Sets the right sideband.
```

Manual operation: See "[Left, Right](#)" on page 103

[SENSe<Sensor>:]FREQUency:CONVersion:MIXer:IF:SIDeband:AUTO[:STATe] <state>

Enables or disables the automatic setting of the intermediate frequency sideband.

Parameters:

```
<state>      *RST:    ON
```

Example: `FREQ:CONV:MIX:IF:SID:AUTO ON`

Manual operation: See "[Sideband](#)" on page 103

[SENSe<Sensor>:]FREQuency:CONVersion:MIXer:LO[:CUV]?

Queries the currently used local oscillator (LO) frequency.

Example: `FREQ:LO?`
 Query
`1.025000E+09`
 Result in Hz

Usage: Query only

Manual operation: See "[Used Internal LO, Expected External LO](#)" on page 103

[SENSe<Sensor>:]FREQuency:CONVersion:MIXer:LO:OUTPut[:STATe] <state>

Enables or disables the output of the local oscillator signal. See [Chapter 9.4.1, "Local oscillator signal"](#), on page 102.

Parameters:

<state> **OFF**
 No signal is output. You can use the LO I/O connector as an input.

ON
 LO signal is output.
 Setting `[SENSe<Sensor>:]FREQuency:CONVersion:MIXer:LO:SOURce EXTernal` at the same time causes a static error.

*RST: OFF

Example: `FREQ:CONV:MIX:LO:OUTP OFF`

Manual operation: See "[LO I/O](#)" on page 103

[SENSe<Sensor>:]FREQuency:CONVersion:MIXer:LO:SOURce <source>

Sets the local oscillator source.

The usage of the external sampling clock requires an external LO signal. To avoid setting conflicts, the following combination is not allowed:

- External sampling clock enabled
- Internal LO source

Parameters:

<source> INTernal | EXTernal

INTernal
 Uses the internal LO signal.

EXtErnal

Uses the external LO signal fed into the LO connector. The internal LO generation is disabled.

Setting `[SENSe<Sensor>:]FREQUency:CONVersion:MIXer:LO:OUTPut[:STATe]` ON at the same time causes a static error.

*RST: INTernal

Example: `FREQ:CONV:MIX:LO:SOUR EXT`

Manual operation: See "[Local Oscillator \(LO\) - Source](#)" on page 103

[SENSe<Sensor>:]FREQUency:TRACk <state>

Enables or disables the frequency tracker. See [Chapter 7.2.1, "Frequency tracker"](#), on page 50.

Parameters:

<state> *RST: OFF

Example: `FREQ:TRAC OFF`

Manual operation: See "[Switch](#)" on page 104

[SENSe<Sensor>:]FREQUency:TRACk:CUV[:STATe]?

Queries the current state of the frequency tracker.

Example: `FREQ:TRAC:CUV?`
Query
0
Result

Usage: Query only

Manual operation: See "[Switch](#)" on page 104

[SENSe<Sensor>:]FREQUency:TRACk:FREQUency?

Queries the tracking frequency. See [Chapter 7.2.1, "Frequency tracker"](#), on page 50.

Usage: Query only

Manual operation: See "[Tracking Frequency](#)" on page 104

12.9.9 Configuring the sensor

Further information:

- [Chapter 12.9, "Configuring measurement settings"](#), on page 144

Web user interface:

- [Chapter 9.5.2, "Sensor parameters"](#), on page 105

Remote commands:

[SENSe<Sensor>:]ROSCillator:PASSthrough.....	175
[SENSe<Sensor>:]ROSCillator:REFio:FREQUENCY.....	175
[SENSe<Sensor>:]ROSCillator:REFio:OUTPut[:STATe].....	176
[SENSe<Sensor>:]ROSCillator:SOURce.....	176
[SENSe<Sensor>:]SAMPLing:CLKio:OUTPut[:STATe].....	176

[SENSe<Sensor>:]ROSCillator:PASSthrough <state>

Requires the phase coherent measurements option (R&S NRQ6-K3).

Configures the usage of the external sampling clock.

The usage of the external sampling clock requires an external LO signal. To avoid setting conflicts, the following combination is not allowed:

- External sampling clock enabled
- Internal LO source

Parameters:

<state>

OFF

Uses the internally generated 10 MHz reference signal to derive the sampling clock signal.

ON

Enables the use of an external sampling clock supplied at the clock I/O (CLK) connector.

*RST: OFF

Manual operation: See "[Clock Distribution Mode - Use Ext. Sampling Clock](#)" on page 106

[SENSe<Sensor>:]ROSCillator:REFio:FREQUENCY <freq>

Only effective for [SENSe<Sensor>:]ROSCillator:SOURceREFio.

Sets the frequency of the reference clock signal that is supplied at the REF connector.

See [Table 9-2](#).

Parameters:

<freq>

Keep the reset value. A value other than 10 MHz is not recommended.

Range: 10e6 to 120e6

Increment: 10e6

*RST: 10e6

Default unit: Frequency

Example: ROSC:REF:FREQ 10000000

Manual operation: See "[Reference Input](#)" on page 106

[SENSe<Sensor>:]ROSCillator:REFio:OUTPut[:STATe] <state>

If the REF connector is used as an output, enables or disables the output signal.

See also [Table 9-2](#).

Parameters:

<state> *RST: OFF

Example: ROSC:REF:OUTP OFF

Manual operation: See "[Reference I/O](#)" on page 106

[SENSe<Sensor>:]ROSCillator:SOURce <source>

Sets the source of the reference oscillator.

Parameters:

<source> INTernal | HOST | REFio

See [Chapter 9.5.1, "Clock source configuration"](#), on page 104.

*RST: INTernal

Example: ROSC:SOUR INT

Manual operation: See "[Source](#)" on page 105

[SENSe<Sensor>:]SAMPLing:CLKio:OUTPut[:STATe] <state>

If the CLK connector is used as an output, enables or disables the output signal.

See also [Table 9-2](#).

Parameters:

<state> *RST: OFF

Example: SAMP:CLK:OUTP OFF

Manual operation: See "[Clock I/O](#)" on page 106

12.10 Configuring the system

The SYSTem subsystem contains a series of commands for general functions that do not directly affect the measurement.

Web user interface:

- [Chapter 10.2, "System parameters"](#), on page 108

Remote commands:

SYSTem:COMMunicate:NETWork:IPADdress	177
SYSTem:COMMunicate:NETWork:IPADdress:GATeway	178
SYSTem:COMMunicate:NETWork:IPADdress:INFO?	178
SYSTem:COMMunicate:NETWork:IPADdress:MODE	178

SYSTem:COMMunicate:NETWork:IPADdress:SUBNet:MASK.....	178
SYSTem:COMMunicate:NETWork:REStart.....	179
SYSTem:COMMunicate:NETWork:RESet.....	179
SYSTem:COMMunicate:NETWork:STATus?.....	179
SYSTem:COMMunicate:NETWork[:COMMOn]:DOMain.....	179
SYSTem:COMMunicate:NETWork[:COMMOn]:HOSTname.....	179
SYSTem:COMMunicate:PSERvoing:BCLock.....	180
SYSTem:COMMunicate:PSERvoing:TPATtern.....	180
SYSTem:DFPRint<Channel>?.....	180
SYSTem:ERRor:ALL?.....	181
SYSTem:ERRor:CODE:ALL?.....	181
SYSTem:ERRor:CODE[:NEXT]?.....	181
SYSTem:ERRor:COUNT?.....	181
SYSTem:ERRor[:NEXT]?.....	182
SYSTem:FWUPdate.....	182
SYSTem:FWUPdate:STATus?.....	182
SYSTem:HELP:HEADers?.....	183
SYSTem:HELP:SYNTax?.....	183
SYSTem:HELP:SYNTax:ALL?.....	183
SYSTem:INFO?.....	183
SYSTem:INITialize.....	184
SYSTem:LANGuage.....	185
SYSTem:LED:COLor.....	185
SYSTem:LED:MODE.....	185
SYSTem:LICense:KEY.....	186
SYSTem:LICense:XML.....	186
SYSTem:MINPower?.....	186
SYSTem:MINPower:UNIT.....	187
SYSTem:PARAmeters?.....	187
SYSTem:PARAmeters:DELTA?.....	187
SYSTem:PRESet.....	187
SYSTem:REBoot.....	187
SYSTem:REStart.....	188
SYSTem[:SENSor]:NAME.....	188
SYSTem:SERRor?.....	188
SYSTem:SERRor:LIST:ALL?.....	188
SYSTem:SERRor:LIST[:NEXT]?.....	188
SYSTem:VERSion?.....	189

SYSTem:COMMunicate:NETWork:IPADdress <ipaddress>

Effective only if `SYSTem:COMMunicate:NETWork:IPADdress:MODE` is set to `STATic`.

Sets the IP address of the R&S NRQ6.

Parameters:

<ipaddress>

Example:

```
SYST:COMM:NETW:IPAD '192.168.10.29'
```

Sets *192.168.10.29* as IP address.

Manual operation: See "IP Address" on page 108

SYSTem:COMMunicate:NETWork:IPADdress:GATeway <gateway>

Effective only if `SYSTem:COMMunicate:NETWork:IPADdress:MODE` is set to `STATic`.

Sets the address of the default gateway, that means the router that is used to forward traffic to destinations beyond the local network. This router is on the same network as the power sensor.

Parameters:

<gateway>

Example: `SYST:COMM:NETW:IPAD:GAT '192.168.10.254'`
Sets 192.168.10.254 as IP address of the default gateway.

Manual operation: See "Gateway" on page 109

SYSTem:COMMunicate:NETWork:IPADdress:INFO?

Queries the network status information.

Usage: Query only

SYSTem:COMMunicate:NETWork:IPADdress:MODE <mode>

Sets how the IP address is assigned.

Parameters:

<mode> AUTO | STATic

AUTO

Assigns the IP address automatically, provided the network supports the dynamic host configuration protocol (DHCP).

STATic

Enables assigning the IP address manually.

*RST: AUTO

Example: `SYST:COMM:NETW:IPAD:MODE AUTO`
The IP address is assigned automatically.

Manual operation: See "DHCP" on page 109

SYSTem:COMMunicate:NETWork:IPADdress:SUBNet:MASK <netmask>

Effective only if `SYSTem:COMMunicate:NETWork:IPADdress:MODE` is set to `STATic`.

Sets the subnet mask.

Parameters:

<netmask> The subnet mask consists of four number blocks separated by dots. Every block contains 3 numbers in maximum.

Example:

```
SYST:COMM:NETW:IPAD:SUBN:MASK '255.255.255.0'
```

Sets *255.255.255.0* as subnet mask.

Manual operation: See "[Subnet Mask](#)" on page 109

SYSTem:COMMunicate:NETWork:REStart

Restarts the network connection to the DUT, that means terminates the connection and sets it up again.

Example:

```
SYST:COMM:NETW:REST
```

Usage:

Event

SYSTem:COMMunicate:NETWork:RESet

Resets the LAN network settings to the default values.

Usage:

Event

SYSTem:COMMunicate:NETWork:STATus?

Queries the network configuration state.

Example:

```
SYST:COMM:NETW:STAT?
```

Query

UP

Response: The network is active.

Usage:

Query only

SYSTem:COMMunicate:NETWork[:COMMOn]:DOMain <domain>

Sets the domain of the network.

Parameters:

<domain>

Example:

```
SYST:COMM:NETW:COMM:DOM 'ABC.DE'
```

Sets *ABC.DE* as domain of the network.

SYSTem:COMMunicate:NETWork[:COMMOn]:HOSTname <hostname>

Sets the individual hostname of the sensor.

In a LAN that uses a DNS server (domain name system server), you can access each connected instrument using a unique hostname instead of its IP address. The DNS server translates the hostname to the IP address. Using a hostname is especially useful if a DHCP server is used, as a new IP address can be assigned each time the instrument is restarted.

The R&S NRQ6 performs the change of the hostname immediately after the command is sent. For this purpose, the R&S NRQ6 restarts its connection to the network, which can take several seconds. During this time, you cannot address the R&S NRQ6. After the restart, you can only address the R&S NRQ6 using the newly set hostname.

Note: It is recommended that you do not change the default hostname to avoid problems with the network connection. However, if you change the hostname, be sure to use a unique name.

Parameters:

<hostname>

Example:

```
SYST:COMM:NETW:COMM:HOST
```

```
'powersensor-2nd-floor'
```

Sets *powersensor-2nd-floor* as new hostname.

SYSTem:COMMunicate:PSERvoing:BCLock <value>

Requires the power servoing option (R&S NRQ6-K2).

Used for internal communication between the R&S SGT100A and the R&S NRQ6. Sets the clock rate of the serial interface.

Parameters:

<value>

Range: 1e6 to 100e6

*RST: 10e6

Default unit: Frequency

SYSTem:COMMunicate:PSERvoing:TPATtern <value>

Requires the power servoing option (R&S NRQ6-K2).

Used for internal communication between the R&S SGT100A and the R&S NRQ6. Sets the bit pattern for the connection test of the serial interface.

Parameters:

<value>

Range: std::numeric_limits<int>::min() to std::numeric_limits<int>::max()

*RST: 0

SYSTem:DFPRint<Channel>?

Reads the footprint file of the sensor.

Suffix:

<Channel>

1 to 4

Measurement channel if more than one channel is available.

Usage: Query only

SYSTem:ERRor:ALL?

Queries all unread entries in the error/event queue and removes them from the queue.

The response is a comma-separated list in first out order, each entry consisting of the error number and a short description of the error.

Positive error numbers are instrument-dependent. Negative error numbers are reserved by the SCPI standard.

Example: SYST:ERR:ALL?
 Query
 0, "No error"
 Response

Usage: Query only

SYSTem:ERRor:CODE:ALL?

Queries all unread entries in the error/event queue and removes them from the queue. Only the error numbers are returned.

Example: SYST:ERR:CODE:ALL?
 Query
 0
 Response: No errors have occurred since the error queue was last read out.

Usage: Query only

SYSTem:ERRor:CODE[:NEXT]?

Queries the oldest entry in the error queue and then deletes it. Only the error number is returned.

Example: SYST:ERR:CODE?
 Query
 0
 Response: No errors have occurred since the error queue was last read out.

Usage: Query only

SYSTem:ERRor:COUNT?

Queries the number of entries in the error queue.

Example: `SYST:ERR:COUN?`
 Query
 1
 Response: One error has occurred since the error queue was
 last read out.

Usage: Query only

SYSTem:ERRor[:NEXT]?

Queries the error/event queue for the oldest entry and removes it from the queue. The response consists of an error number and a short description of the error.

See also "[Querying errors \(remote control\)](#)" on page 207.

Example: `SYST:ERR?`
 Query
 0, 'no error'
 Response: No errors have occurred since the error queue was
 last read out.

Usage: Query only

SYSTem:FWUPdate <fwudata>

Loads new operating firmware into the R&S NRQ6. Rohde & Schwarz provides the update file. For further details, see [Chapter 11, "Firmware update"](#), on page 112.

If you want to integrate a firmware update function in an application, see the example given in [Chapter 11.2.3, "Using remote control"](#), on page 116.

Setting parameters:

<fwudata> <block_data>
 Definite length arbitrary block data containing the direct copy of
 the binary *.rsu file in the following format:
 #
 Single digit indicating how many digits follow to specify the size
 of the binary file.
 Number that specifies the size of the binary file.
 Binary data
 0x0a as appended delimiter for line feed

Usage: Setting only

Manual operation: See "[Firmware Update](#)" on page 110

SYSTem:FWUPdate:STATus?

Reads the result of the firmware update performed using `SYSTem:FWUPdate`.

While a firmware update is in progress, the LED of the sensor flashes in bright white color. When the firmware update is completed, you can read the result.

The result of the query is a readable string.

Example: `SYST:FWUP:STAT?`
 Query
 "Success"
 Response

Usage: Query only

Manual operation: See "[Firmware Update](#)" on page 110

SYSTem:HELP:HEADers? [<Item>]

Returns a list of all SCPI commands supported by the sensor.

Query parameters:
 <Item> <block_data>

Usage: Query only

SYSTem:HELP:SYNTax? [<Item>]

Queries the relevant parameter information for the specified SCPI command.

Query parameters:
 <Item>

Example: `SYST:HELP:SYNT? 'sens:aver:coun'`

Usage: Query only

SYSTem:HELP:SYNTax:ALL?

Queries the implemented SCPI commands and their parameters. Returns the result as a block data.

Usage: Query only

SYSTem:INFO? [<item>]

Queries information about the system.

If queried without parameters, the command returns all available information in the form of a list of strings separated by commas.

If you want to query specific information, add a query parameter:

`SYST:INFO? "<string>"`

Query parameters:
 <item> "<string>" with the following values:
 Manufacturer
 Type
 Stock Number

Serial
SW Build
MAC Address
Hostname
IP Address
Sensor Name
Technology
Function
MinPower
MaxPower
MinFreq
MaxFreq
Resolution
Impedance
Coupling
Cal Due Date
TestLimit
Uptime

Example:

```

SYST:INFO?
Query
"Manufacturer:Rohde & Schwarz Type:
NRQ6 Stock Number:1421.3509K02 Serial:
900041 SW Build:02.10.19090301 MAC Address:
00:90:b8:1e:
57:19 Hostname:nrq6-900041 IP Address:
10.111.0.157 Sensor Name:
NRQ6-900041 Technology:
Frequency Selective Function:
Power Terminating MinPower:1e-17 MaxPower:
0.1 MinFreq:5e+07 MaxFreq:6e+09 Resolution:
8.33333e-09 Impedance:
50 Coupling:AC Cal. Due Date:2018-12 TestLimit:
0.160 dB Uptime:24 "
Response

```

Usage: Query only

Manual operation: See "[Device ID](#)" on page 111

SYSTem:INITialize

Sets the sensor to the standard state.

The sensor loads the default settings for all test parameters in the same way as when using `*RST`. The sensor outputs a complete list of all supported commands and parameters. The remote-control software can automatically adapt to the features of different types of sensors with different functionality.

Usage: Event

SYSTem:LANGuage <language>

Selects an emulation of a different command set.

Parameters:

<language> SCPI
 *RST: SCPI

SYSTem:LED:COLor <color>

Sets the color and the flash code of the system status LED, if the operating mode of the LED is set to `USER` (`SYSTem:LED:MODE` on page 185 `USER`).

Parameters:

<color> Hexadecimal code described as
 0x0krrggbb
 with
 k = 0: steady on; k = 1: slowly flashing; k = 2: fast flashing
 rr = red
 gg = green
 bb = blue
 Range: 0 to 0x0FFFFFFF
 *RST: 0x00A0A0A0

Example:

```
SYST:LED:MODE USER
Sets the system status LED operating mode to user.
```

```
SYST:LED:COL #H01a00000
The LED flashes slowly in red.
```

```
SYSTem:LED:MODE SENSOor
Sets the system status LED operating mode back to the sensor
internal settings.
```

SYSTem:LED:MODE <mode>

Selects whether the color of the system status LED is controlled by the sensor firmware or by the user settings.

For more information, see `SYSTem:LED:COLor` on page 185.

Parameters:

<mode> USER | SENSor
 *RST: SENSor

SYSTem:LiCense:KEY <key>

Installs the license key for the option key management. To make the new option available, reboot the sensor using [SYSTem:REBoot](#).

Check the installed options using [*OPT?](#) on page 121.

Setting parameters:

<key> The <key> string contains the license key from the software option list supplied with the option.

Usage: Setting only

Manual operation: See "[License Key](#)" on page 111

SYSTem:LiCense:XML <xmlfile>

Installs the license key for the option key management. To make the new option available, reboot the sensor using [SYSTem:REBoot](#).

Check the installed options using [*OPT?](#) on page 121.

Setting parameters:

<xmlfile> <block_data>
 Definite length arbitrary block data containing the direct copy of the binary * .xml file in the following format:
 #
 Single digit indicating how many digits follow to specify the size of the binary file.
 Number that specifies the size of the binary file.
 Binary data
 0x0a as appended delimiter for line feed
 See also [Chapter 11.2.3, "Using remote control"](#), on page 116.

Usage: Setting only

Manual operation: See "[Browse License File](#)" on page 111

SYSTem:MINPower?

Queries the lower power measurement limit. Use this query to determine a useful resolution for the result display near the lower measurement limit.

The lower measurement limit refers to the power sensor or to the combination of a power sensor with an S-parameter device attached to it, depending on the setting of [\[SENSe<Sensor>:\]CORRection:SPDevice<undef>:STATe](#):

- Disabled: The query returns the minimum power of the power sensor.

- Enabled: The query returns the minimum power of the power sensor with the S-parameter device attached to it. The same value is returned by `[SENSe<Sensor>:]CORRection:SPDevice<Device>:MINPower`.

Set the unit using `SYSTem:MINPower:UNIT`.

Usage: Query only

SYSTem:MINPower:UNIT <unit>

Sets the unit for the lower power measurement limit, queried by `SYSTem:MINPower?`.

Parameters:

<unit> DBM | W | DBUV
*RST: W

SYSTem:PARAmeters?

Lists all commands with default values, limits and ranges.

Usage: Query only

SYSTem:PARAmeters:DELTA?

Lists all commands that differ from the defined default status set by `*RST` on page 121.

The commands are output with default values, limits and ranges.

Usage: Query only

SYSTem:PRESet

Triggers a sensor reset.

The command essentially corresponds to the `*RST` command, with the exception that the settings of the following commands are persistently held:

`INITiate:CONTinuous` on page 128

`[SENSe<Sensor>:]AVERAge:TCONtrol` on page 146

`[SENSe<Sensor>:]TRACe:AVERAge:TCONtrol` on page 148

Usage: Event

SYSTem:REBoot

Reboots the R&S NRQ6.

Usage: Event

Manual operation: See "Reboot Sensor" on page 110

See "Reboot" on page 111

SYSTem:REStart

Restarts the firmware of the R&S NRQ6.

Usage: Event

SYSTem[:SENSor]:NAME <sensorname>

Sets the sensor name. The sensor name is displayed in the title bar of the web user interface, see (1) in [Figure 5-1](#).

If you do not specify a sensor name, the hostname is used as default. See also [SYSTem:COMMunicate:NETWork\[:COMMON\]:HOSTname](#) on page 179.

Parameters:

<sensorname>

Example: SYST:NAME "InputModule-X5"

Manual operation: See "[Sensor Name](#)" on page 109

SYSTem:SERRor?

Queries all static errors that are currently present.

See also "[Querying errors \(remote control\)](#)" on page 207.

Usage: Query only

SYSTem:SERRor:LIST:ALL?

Queries all changes in the static error queue that have not been read yet and removes them from the queue.

Example:

```
SYST:SERR:LIST:ALL?
```

```
Response: 0,"reported at uptime:2942; notice;  
auto-averaging exceeded maximum time;  
Notification",0,"removed at uptime:2944;  
notice; auto-averaging exceeded maximum time;  
Notification".
```

Usage: Query only

SYSTem:SERRor:LIST[:NEXT]?

Queries the list of all static errors that have occurred but have already been resolved for the oldest entry and removes it from the queue. The response consists of an error number and a short description of the error.

Example: SYST:SErr:LIST?
Query
 0,"reported at uptime:2942; notice;
 auto-averaging exceeded maximum time;
 Notification"
Response

Usage: Query only

SYSTem:VERSion?

Queries the SCPI version that the command set of the sensor complies with.

Example: SYST:VERS?
Query
 1999.0
Response: SCPI version from 1999.

Usage: Query only

12.11 Using the status register

Further information:

- [Chapter 14.2, "Status reporting system"](#), on page 196

Contents:

- [General status register commands](#)..... 189
- [Reading the CONDition part](#)..... 190
- [Reading the EVENT part](#)..... 190
- [Controlling the ENABle part](#)..... 190
- [Controlling the negative transition part](#)..... 191
- [Controlling the positive transition part](#)..... 191

12.11.1 General status register commands

- [STATus:PRESet](#)..... 189
- [STATus:QUEue\[:NEXT\]?](#)..... 189

STATus:PRESet

Resets the edge detectors and ENABle parts of all registers to a defined value.

Usage: Event

STATus:QUEue[:NEXT]?

Queries the most recent error queue entry and deletes it.

Positive error numbers indicate sensor specific errors. Negative error numbers are error messages defined by SCPI.

If the error queue is empty, the error number 0, "No error", is returned.

Usage: Query only

12.11.2 Reading the CONDition part

STATus:DEvice:CONDition?
STATus:OPERation:CALibrating:CONDition?
STATus:OPERation:CONDition?
STATus:OPERation:LLFail:CONDition?
STATus:OPERation:MEASuring:CONDition?
STATus:OPERation:SENSe:CONDition?
STATus:OPERation:TRIGger:CONDition?
STATus:OPERation:ULFail:CONDition?
STATus:QUEStionable:CALibration:CONDition?
STATus:QUEStionable:CONDition?
STATus:QUEStionable:POWer:CONDition?
STATus:QUEStionable:WINDow:CONDition?
Usage: Query only

12.11.3 Reading the EVENT part

STATus:DEvice[:EVENT]?
STATus:OPERation:CALibrating[:SUMMARY][:EVENT]?
STATus:OPERation[:EVENT]?
STATus:OPERation:LLFail[:SUMMARY][:EVENT]?
STATus:OPERation:MEASuring[:SUMMARY][:EVENT]?
STATus:OPERation:SENSe[:SUMMARY][:EVENT]?
STATus:OPERation:TRIGger[:SUMMARY][:EVENT]?
STATus:OPERation:ULFail[:SUMMARY][:EVENT]?
STATus:QUEStionable:CALibration[:SUMMARY][:EVENT]?
STATus:QUEStionable[:EVENT]?
STATus:QUEStionable:POWer[:SUMMARY][:EVENT]?
STATus:QUEStionable:WINDow[:SUMMARY][:EVENT]?
Usage: Query only

12.11.4 Controlling the ENABLE part

STATus:DEvice:ENABLE <value>
STATus:OPERation:CALibrating:ENABLE <value>
STATus:OPERation:ENABLE <value>
STATus:OPERation:LLFail:ENABLE <value>
STATus:OPERation:MEASuring:ENABLE <value>

```

STATus:OPERation:SENSe:ENABLE <value>
STATus:OPERation:TRIGger:ENABLE <value>
STATus:OPERation:ULFail:ENABLE <value>
STATus:QUEStionable:CALibration:ENABLE <value>
STATus:QUEStionable:ENABLE <value>
STATus:QUEStionable:POWer:ENABLE <value>
STATus:QUEStionable:WINDow:ENABLE <value>
Parameters:
<value>          *RST:      0

```

12.11.5 Controlling the negative transition part

```

STATus:DEVIce:NTRansition <value>
STATus:OPERation:CALibrating:NTRansition <value>
STATus:OPERation:NTRansition <value>
STATus:OPERation:LLFail:NTRansition <value>
STATus:OPERation:MEASuring:NTRansition <value>
STATus:OPERation:SENSe:NTRansition <value>
STATus:OPERation:TRIGger:NTRansition <value>
STATus:OPERation:ULFail:NTRansition <value>
STATus:QUEStionable:CALibration:NTRansition <value>
STATus:QUEStionable:NTRansition <value>
STATus:QUEStionable:POWer:NTRansition <value>
STATus:QUEStionable:WINDow:NTRansition <value>
Parameters:
<value>          *RST:      0

```

12.11.6 Controlling the positive transition part

```

STATus:DEVIce:PTRansition <value>
STATus:OPERation:CALibrating:PTRansition <value>
STATus:OPERation:PTRansition <value>
STATus:OPERation:LLFail:PTRansition <value>
STATus:OPERation:MEASuring:PTRansition <value>
STATus:OPERation:SENSe:PTRansition <value>
STATus:OPERation:TRIGger:PTRansition <value>
STATus:OPERation:ULFail:PTRansition <value>
STATus:QUEStionable:CALibration:PTRansition <value>
STATus:QUEStionable:PTRansition <value>
STATus:QUEStionable:POWer:PTRansition <value>
STATus:QUEStionable:WINDow:PTRansition <value>
Parameters:
<value>          *RST:      65535

```

13 Programming examples

If you install the optional software development kit (SDK) of the R&S NRP Toolkit, programming examples are provided. See [Chapter 5.1.3, "R&S NRP Toolkit for Windows"](#), on page 33.

Under Windows, these examples are installed under:

```
C:\ProgramData\Rohde-Schwarz\NRP-Toolkit-SDK\examples\NRQ6
```

The following programming examples are available for the R&S NRQ6:

- ACLR measurement
- Don't miss a pulse
- Using the frequency tracker
- Measuring at low levels
- S-parameter correction
- Feed for vector signal explorer (VSE)
Writes the measured I/Q data into a *.CSV file. Requires the I/Q data interface (R&S NRQ6-K1).
- Phase analysis
Requires the I/Q data interface (R&S NRQ6-K1) and the phase coherent measurements (R&S NRQ6-K3).

14 Remote control basics

For general information on remote control of Rohde & Schwarz products via SCPI, refer to www.rohde-schwarz.com/rc-via-scpi.

14.1 Remote control interfaces and protocols

For remote control, communication between the R&S NRQ6 and the controlling host is established based on the following interfaces and protocols.

Table 14-1: Supported interfaces and protocols

Interface	Protocol	VISA ^{*)} address string	Library
USB	USBTMC	USB:: <vendor id>::<product="" id>::<serial="" number>::<instr]<="" td=""> <td>VISA</td> </vendor>	VISA
Ethernet	VXI-11	TCPIP::host address>::LAN device name>::INSTR]	VISA
	HiSLIP High-speed LAN instrument protocol (IVI-6.1)	TCPIP::host address>::hislip0>::INSTR]	VISA
	Socket communication (LAN Ethernet)	TCPIP::host address>::LAN device name>::<port>::SOCKET	
<p>^{*)} VISA is a standardized software interface library providing input and output functions to communicate with instruments. A VISA installation on the controller is a prerequisite for remote control over LAN (when using VXI-11 or HiSLIP protocol) and USBTMC interfaces. See also Chapter 14.1.2.1, "VISA resource strings", on page 195.</p>			

14.1.1 USB interface

Computer requirements

- VISA library
A USB connection requires the VISA library to be installed. VISA detects and configures the R&S NRQ6 automatically when the USB connection is established.
- USBTMC driver
Apart from the USBTMC driver, which comes with the installation of the R&S NRP Toolkit, you do not have to install a separate driver.

Setup

1. Connect the host interface of the R&S NRQ6 and the USB interface of the computer.
See [Chapter 3.6.2, "Computer using a USB connection"](#), on page 22.

2. Make sure that the R&S NRQ6 is powered by PoE+. For details, see "[R&S NRQ6 requires PoE+](#)" on page 29.

USBTMC protocol

USB Test & Measurement Class Specification (USBTMC) is a protocol that is built on top of USB for communication with USB devices from the test & measurement category. It defines a dedicated class code that identifies a device's functionality. R&S NRQ6 also uses this class code to identify itself as a member of the test & measurement class. Using a VISA library, such devices support service request, trigger and other operations that are commonly found in GPIB devices.

USB resource string

The VISA resource string for USBTMC device communication represents an addressing scheme that is used to establish a communication session with the power sensor. It is based on the power sensor address and some power sensor- and vendor-specific information. The syntax of the used USB resource string is:

USB::*<vendor ID>*::*<product ID>*::*<serial number>*[::INSTR]

- *<vendor ID>* is the vendor ID for Rohde & Schwarz.
- *<product ID>* is the product ID for the R&S NRQ6.
- *<serial number>* is the individual serial number of the R&S NRQ6, printed on the casing.

Example:

```
USB::0x0AAD::0x015B::100001
```

0x0AAD is the vendor ID for Rohde & Schwarz.

0x015B is the product ID for the R&S NRQ6.

100001 is the serial number of the particular R&S NRQ6.

14.1.2 Ethernet interface

The Ethernet interface of the R&S NRQ6 allows you to integrate it in a local area network (LAN).

Requirements

- TCP/IP network protocol
The local area network must support the TCP/IP network protocol.
The TCP/IP network protocol and the associated network services are preconfigured on the R&S NRQ6.
- VISA library
Installed on the computer.
- Software for device control
Installed on the computer.

Setup

1. Using the Ethernet interface, connect the computer and the R&S NRQ6 to a local area network. See [Chapter 3.6.1, "Computer using a LAN connection"](#), on page 17.
2. Make sure that the R&S NRQ6 is powered by PoE+. For details, see ["R&S NRQ6 requires PoE+"](#) on page 29.

14.1.2.1 VISA resource strings

The VISA resource string is required to establish a communication session between the controller and the power sensor in a LAN. The resource string is a unique identifier, composed of the specific IP address of the power sensor and some network and VISA-specific keywords.

TCPIP::*<IP address or hostname>*[:*<LAN device name>*][:INSTR]

- *TCPIP* designates the network protocol used
- *<IP address or hostname>* is the IP address or host name of the device
- *[:<LAN device name>]* defines the protocol and the instance number of a sub-instrument:
- *[:INSTR]* indicates the power sensor resource class (optional)

The IP address or hostname is used by the programs to identify and control the power sensor. While the hostname is determined by settings in the power sensor, the IP address is assigned by a DHCP server when the power sensor requests one. Alternatively the IP address is determined with a procedure called Zeroconf.

You can also assign a *LAN device name* which defines the protocol characteristics of the connection. See the description of the VISA resource string below for the corresponding interface protocols. The string of the *LAN device name* is emphasized in italics.

HiSLIP

TCPIP::*<IP address or hostname>*::*hislip0*[:INSTR]

- *hislip0* is the HiSLIP device name, designates that the interface protocol HiSLIP is used (mandatory)

hislip0 is composed of *[:HiSLIP device name[,HiSLIP port]]* and must be assigned.

VXI-11

TCPIP::*<IP address or hostname>*[:*inst0*][:INSTR]

- *inst0* is the LAN device name, indicating that the VXI-11 protocol is used (optional)
- inst0* currently selects the VXI-11 protocol by default and can be omitted.

Socket communication

TCPIP::*<IP address or hostname>*::*port*::SOCKET

- *port* determines the used port number
- *SOCKET* indicates the raw network socket resource class

Socket communication requires the specification of the port (commonly referred to as port number) and of "SOCKET" to complete the VISA resource string with the associated protocol used.

The default port for socket communication is port 5025.

Example:

A power sensor has the IP address *10.111.11.20*; the valid resource string using VXI-11 protocol is:

TCPIP::10.111.11.20::INSTR

The DNS host name is *nrq6-100001*; the valid resource string is:

TCPIP::nrq6-100001::hislip0 (HiSLIP)

TCPIP::nrq6-100001::inst0 (VXI-11)

A raw socket connection can be established using:

TCPIP::10.111.11.20::5025::SOCKET

TCPIP::nrq6-100001::5025::SOCKET

14.2 Status reporting system

The status reporting system stores all information on the current operating state of the sensor, and on errors which have occurred. This information is stored in the status registers and in the error queue. You can query both with the commands of the `STATUS` subsystem.

14.2.1 Overview

Fig.14-1 shows the hierarchical structure of information in the status registers.

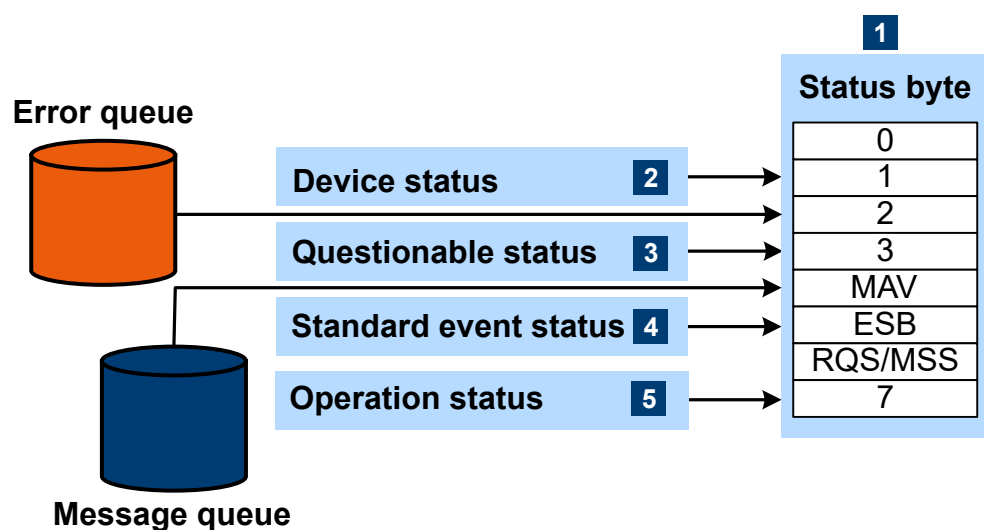

Figure 14-1: Status registers overview

- 1 = Status byte, see [Table 14-2](#)
- 2 = [Chapter 14.2.2, "Device status register"](#), on page 198
- 3 = [Chapter 14.2.3, "Questionable status register"](#), on page 199
- 4 = [Chapter 14.2.4, "Standard event status and enable register \(ESR, ESE\)"](#), on page 201
- 5 = [Chapter 14.2.5, "Operation status register"](#), on page 202

The highest level is formed by the status byte register (STB) and the associated service request enable (SRE) register.

The status byte register (STB) receives its information from:

- Standard event status register (ESR)
- Associated standard event status enable register (ESE)
- SCPI-defined operation status register
- Questionable status register, which contains detailed information on the device.

Table 14-2: Used status byte bits and their meaning

Bit no.	Short description	Bit is set if
1	Device status register summary	A sensor is connected or disconnected or when an error has occurred in a sensor, depending on the configuration of the sensor status register. Chapter 14.2.2, "Device status register" , on page 198.
2	Error queue not empty	The error queue has an entry. If this bit is enabled by the service request enable register, each entry of the error queue generates a service request. An error can thus be recognized and specified in detail by querying the error queue. The query yields a conclusive error message. This procedure is recommended since it considerably reduces the problems of IEC/IEEE-bus control.
3	Questionable status register summary	An <code>EVENT</code> bit is set in the <code>QUESTIONABLE</code> status register and the associated <code>ENABLE</code> bit is set to 1. A set bit denotes a questionable device status which can be specified in greater detail by querying the questionable status register. Chapter 14.2.3, "Questionable status register" , on page 199.
4	MAV Message available	A readable message is in the message queue. This bit can be used to automate reading of data from the sensor into the controller.
5	ESB Standard event status register summary	One of the bits in the standard event status register is set and enabled in the event status enable register. Setting this bit denotes a serious error which can be specified in greater detail by querying the standard event status register. Chapter 14.2.4, "Standard event status and enable register (ESR, ESE)" , on page 201.
6	RQS/MSS Master status summary	The sensor triggers a service request, which happens if one of the other bits of this register is set together with its enable bit in the service request enable register (SRE).
7	Operation status register summary	An <code>EVENT</code> bit is set in the operation status register and the associated <code>ENABLE</code> bit is set to 1. A set bit denotes that an action is being performed by the sensor. Information on the type of action can be obtained by querying the operation status register. Chapter 14.2.5, "Operation status register" , on page 202.

Further information:

- See [Figure 14-1](#).
- Set and read the service request enable register using [*SRE](#).

14.2.2 Device status register

Shows whether static errors (SERR) exist and other power sensor status information.

Sum of bits 1 to 4	0
Measurement not possible	1
Erroneous result	2
Warning	3
Critical	4
0	5
0	6
Legacy locked state	7
Reference PLL locked state	8
0	9
0	10
0	11
0	12
0	13
0	14
0	15

Figure 14-2: Device status register

Querying the register:

- `STATus:DEvice:CONDition?`
- `STATus:DEvice[:EVENT]?`

Querying the static errors:

- `SYSTem:SERRor?`

Table 14-3: Used device status bits and their meaning

Bit no.	Short description	Bit is set if
0	Sum of bits 1 to 4	Sum/combination of static error (SERR) bits 1 to 4.
1	Measurement not possible	
2	Erroneous results	Static error exists. The measurement result is possibly incorrect.
3	Warning	Static error exists. Status LED of the power sensor is slowly flashing red.

Bit no.	Short description	Bit is set if
4	Critical	Critical static error exists. Status LED of the power sensor is fast flashing red.
8	Reference PLL locked state	PLL for the clock reference is synchronized. The bit is useful when selecting an external clock source.

14.2.3 Questionable status register

Contains information on questionable sensor states that occur if the power sensor is not operated in compliance with its specifications.

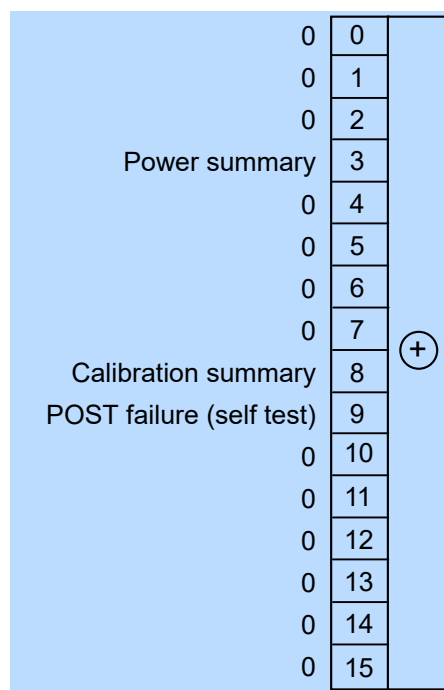

Figure 14-3: Questionable status register

Querying the register:

- `STATUS:QUESTIONABLE:CONDITION?`
- `STATUS:QUESTIONABLE[:EVENT]?`

Table 14-4: Used questionable status bits and their meaning

Bit no.	Short description	Bit is set if
3	Power summary	Summary of Questionable power status register exists.
8	Calibration summary	Summary of Questionable calibration status register exists.
9	POST failure (self test)	Built-in test of the R&S NRQ6 that is carried out automatically upon power-up has generated an error.

14.2.3.1 Questionable power status register

Contains information whether the measured power values are questionable.

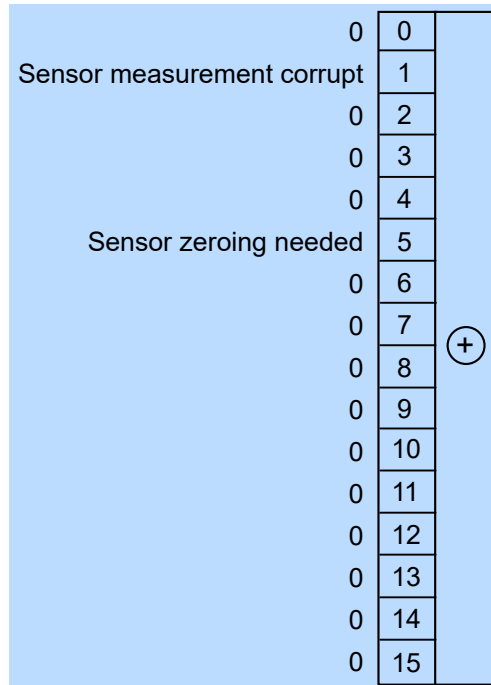

Figure 14-4: Questionable power status register

Querying the register:

- `STATUS:QUESTIONABLE:POWER:CONDITION?`
- `STATUS:QUESTIONABLE:POWER[:SUMMARY][:EVENT]?`

Table 14-5: Used questionable power status bits and their meaning

Bit no.	Short description	Bit is set if
1	Sensor measurement corrupt	Measurement data of the power sensor is corrupt.
5	Sensor zeroing needed	Zero correction for the power sensor is no longer correct. Perform a zero correction.

14.2.3.2 Questionable calibration status register

Contains information whether the zeroing of the power sensor was successful.

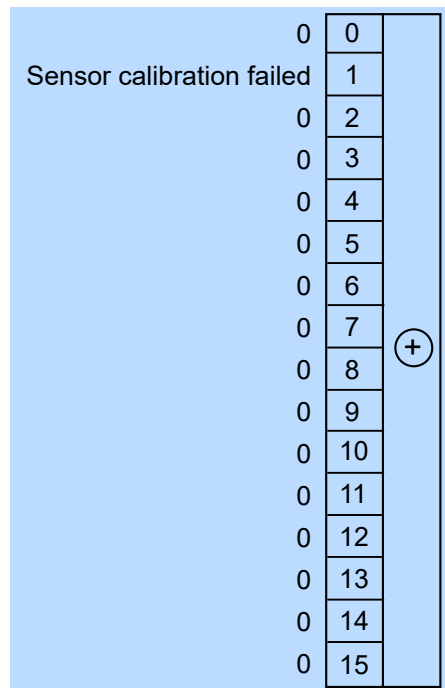

Figure 14-5: Questionable calibration status register

Querying the register:

- `STATUS:QUESTIONABLE:CALIBRATION:CONDITION?`
- `STATUS:QUESTIONABLE:CALIBRATION[:SUMMARY][:EVENT]?`

Table 14-6: Used questionable calibration status bits and their meaning

Bit no.	Short description	Bit is set if
1	Sensor calibration failed	Zeroing of the power sensor was not successful.

14.2.4 Standard event status and enable register (ESR, ESE)

The `ESR` is already defined in the IEEE 488.2 standard. It is comparable to the `EVENT` register of a SCPI register. The standard event status register can be read out by `*ESR?`.

The `ESE` forms the associated `ENABLE` register. It can be set and read by `*ESE`.

Operation Complete	0	+
0	1	
Query Error	2	
Device-Dependent Error	3	
Execution Error	4	
Command Error	5	
User Request	6	
Power On	7	

Figure 14-6: Standard event status register (ESR)

Table 14-7: Used standard event status bits and their meaning

Bit no.	Short description	Bit is set if
0	Operation complete	All previous commands have been executed and *OPC is received.
2	Query error	The controller wants to read data from the sensor but has not sent a query, or it sends new commands to the sensor before it retrieves existing requested data. A frequent cause is a faulty query which cannot be executed.
3	Device-dependent error	A sensor-dependent error occurs. An error message with a number between -300 and -399 or a positive error number denoting the error in greater detail is entered in the error queue.
4	Execution error	The syntax of a received command is correct but the command cannot be executed due to various marginal conditions. An error message with a number between -200 and -300 denoting the error in greater detail is entered in the error queue.
5	Command error	An undefined command or a command with incorrect syntax is received. An error message with a number between -100 and -200 denoting the error in greater detail is entered in the error queue.
6	User request	The sensor is switched over to manual control.
7	Power on	The sensor is switched on.

14.2.5 Operation status register

Contains information on current operations, CONDition register, or operations performed since the last query, EVENT register.

Calibrating	0	+
0	1	
0	2	
0	3	
Measuring	4	
Triggering	5	
0	6	
0	7	
0	8	
0	9	
Sense summary	10	
Lower limit fail	11	
Upper limit fail	12	
0	13	
0	14	
0	15	

Figure 14-7: Operation status register

Querying the register:

- `STATus:OPERation:CONDition?`
- `STATus:OPERation[:EVENT]?`

Table 14-8: Used operation status bits and their meaning

Bit no.	Short description	Bit is set if
0	Calibrating	Summary of Operation calibrating status register exists.
4	Measuring	Summary of Operation measuring status register exists.
5	Triggering	Summary of Operation trigger status register exists.

14.2.5.1 Operation calibrating status register

The `CONDition` register contains information whether a power sensor is being calibrated. The `EVENT` register contains information whether a calibration was started or completed since the last query.

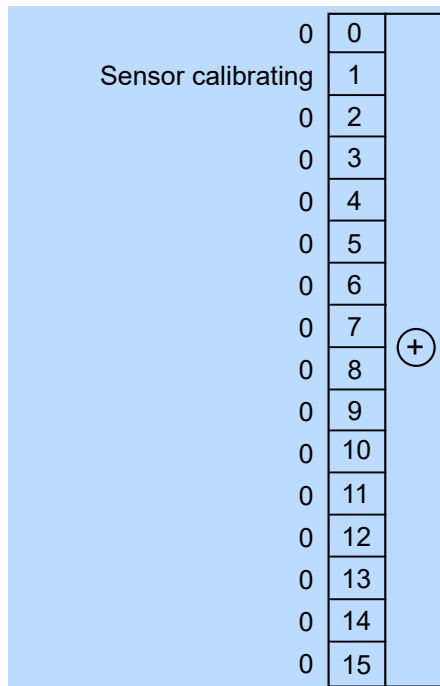

Figure 14-8: Operation calibrating status register

Querying the register:

- `STATUS:OPERation:CALibrating:CONDition?`
- `STATUS:OPERation:CALibrating[:SUMMARY][:EVENT]?`

Table 14-9: Used operation calibrating status bits and their meaning

Bit no.	Short description	Bit is set if
1	Sensor calibrating	Power sensor is being calibrated.

14.2.5.2 Operation measuring status register

The `CONDition` register contains information whether a power sensor is measuring. The `EVENT` register contains information whether a measurement was started or completed since the last query.

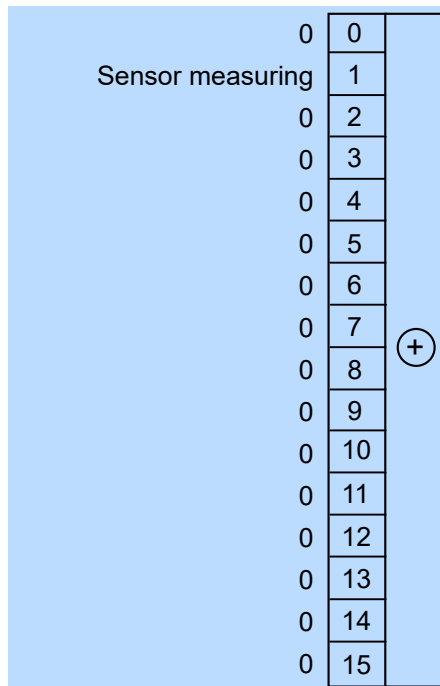

Figure 14-9: Operation measuring status register

Querying the register:

- `STATUS:OPERation:MEASuring:CONDition?`
- `STATUS:OPERation:MEASuring[:SUMMARY][:EVENT]?`

Table 14-10: Used operation measuring status bits and their meaning

Bit no.	Short description	Bit is set if
1	Sensor measuring	Power sensor is measuring.

14.2.5.3 Operation trigger status register

The `CONDition` register contains information whether a power sensor is waiting for a trigger event. The `EVENT` register contains information whether the power sensor has been waiting for a trigger event since the last query.

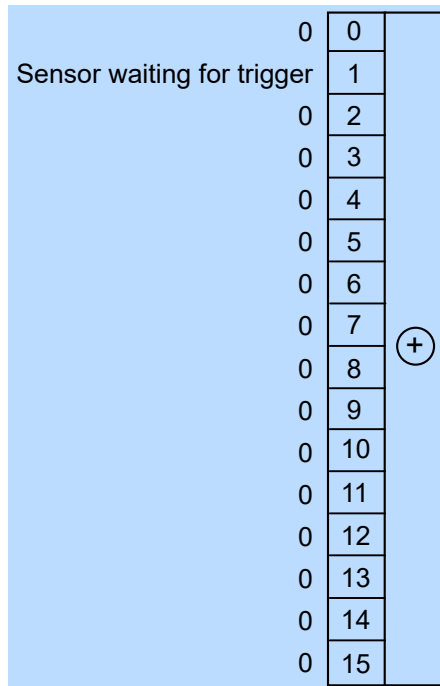

Figure 14-10: Operation trigger status register

Querying the register:

- `STATUS:OPERation:TRIGger:CONDition?`
- `STATUS:OPERation:TRIGger[:SUMMARY][:EVENT]?`

Table 14-11: Used operation trigger status bits and their meaning

Bit no.	Short description	Bit is set if
1	Sensor waiting for trigger	Power sensor is waiting for a trigger event. When the trigger event occurs, the power sensor changes into the measuring state.

15 Troubleshooting

Further information:

- [Chapter 6.6, "Potential sources of error"](#), on page 46
- [Displaying status information](#)..... 207
- [Error messages](#)..... 207
- [Implausible measurement results](#)..... 209
- [Performing a selftest](#)..... 210
- [Problems during a firmware update](#)..... 213
- [Cannot establish a LAN connection](#)..... 213
- [Contacting customer support](#)..... 214

15.1 Displaying status information

Status information is available in several ways.

Status LED of the R&S NRQ6

The position of the status LED is indicated in [Figure 4-1](#).

The meaning of the different colors and blinking frequencies is explained in [Chapter 4.2, "Status information"](#), on page 28.

Title bar of the web user interface

The position of the status icon is indicated in [Figure 5-1](#). The colors are explained in [Chapter 4.2, "Status information"](#), on page 28.

15.2 Error messages

The meaning of error messages is described in [Chapter 15.2.1, "Interpreting the error messages"](#), on page 208.

Displaying error messages (web user interface)

- ▶ In the web user interface, click the status icon in right corner of the title bar.
In the "Sensor Status Information" dialog, all static and normal errors are listed. Identical errors are displayed only once.

Querying errors (remote control)

In remote control, the commands querying errors are part of `SYSTEM`, see [Chapter 12.10, "Configuring the system"](#), on page 176.

The severity of the error is distinguished:

- Normal error

Results from, for example, unknown commands or syntax errors and generally affect a single parameter or setting.

- **Static error**
More severe than a normal error. Prevents the execution of normal measurements.

Positive error numbers are instrument-dependent. Negative error numbers are reserved by the SCPI standard.

You can query the error queue using:

- `SYSTem:ERRor:ALL?`
- `SYSTem:ERRor:COUNT?`
- `SYSTem:ERRor[:NEXT]?`

If you want to look only at static errors, use:

- `SYSTem:SERRor?`
- `SYSTem:SERRor:LIST[:NEXT]?`

15.2.1 Interpreting the error messages

In the following, important error messages and their meaning are explained. For all other errors, execute a selftest to find out whether it is a hardware or software problem, and report the problem to the R&S customer support. See [Chapter 15.4, "Performing a selftest"](#), on page 210.

Current settings exceed specified operating range	208
LO level out of range	208
Current settings exceed calibration range	208
Insufficient memory	209
ADC overrange	209
Ref PLL not locked	209
Sensor overload	209

Current settings exceed specified operating range

Setting conflict.

Reason: For frequencies below 400 MHz, zero-IF bandwidths above 40 MHz are not supported.

LO level out of range

Can occur when supplying an external local oscillator signal.

Reason: The power of the external local oscillator is too high or too low. Or the frequency is not correct.

Current settings exceed calibration range

For the current settings, not all calibration values are found.

Solution: Check whether the R&S NRQ6 operates out of specification, that means exceeding a resolution bandwidth of 40 MHz at 50 MHz RF frequency.

Insufficient memory

Not enough memory for the current settings.

Solution: Decrease the measurement time or the resolution bandwidth. See also [Chapter 7.3.3, "Choosing the correct filter type"](#), on page 54.

ADC overrange

The last acquired measurement contains samples where the ADC range was exceeded and clamped.

Solution: Use 30 dB input attenuation, or reduce the power at the input.

Ref PLL not locked

Locking to the external frequency reference signal failed.

Solution: Adjust the input frequency or REF power level. Or tune the external frequency so that it is inside the permissible range.

Sensor overload

The RF input power exceeds the measurement range by far.

Solution: Reduce the power to prevent permanent damage.

15.3 Implausible measurement results

Implausible trace result

Possible solutions:

- Try using "Autoset".
- Try reducing the trace time.
- Check also the subsequent conditions described in the following topics.

Implausible triggering

Observation: It seems that the signal does not reach the trigger level, but the R&S NRQ6 is triggering.

Reason: The samples that are triggering the R&S NRQ6 are not shown in the display because the display decimation averages out short peaks.

Solution: Reduce the trace time (`[SENSe<Sensor>:] TRACe:TIME`) until the trace output (`[SENSe<Sensor>:] TRACe:RLENgth[:CUV]?`) corresponds directly to the samples (`[SENSe<Sensor>:] TRACe:POINts`) used in the trigger.

Implausible results in zero-IF mode

If $RBW > 40$ MHz.

Observations:

- Large zero offset without input power is applied.
- Constant power level causes oscillation in the trace result.

Reason: DC offset corrupts the result.

Solution: Every time you alter the configuration, before you start the measurement, perform DC zeroing. See also [Chapter 9.3.2.2, "DC zeroing"](#), on page 98.

- Send `CALibration<Channel>:ZERO:AUTO ONCE`.
- If you use the web user interface: On the "Correction" tab, click [DC Zeroing](#).

15.4 Performing a selftest

The selftest gives you detailed information that you can use for troubleshooting.



During the selftest, do not apply a signal because this can cause erroneous test results.

Using the web user interface

1. In the navigation pane of the main dialog, select "System".
2. Under "Diagnostics", click "Selftest".

For each test step, PASS or FAIL is listed. For interpreting the test results, see [Chapter 15.4.1, "Interpreting the test results"](#), on page 211.

Selftest Results:

Power Applied	PASS
Operating Voltages	PASS
Temperatures	PASS
Test Generator	PASS
LO Level	PASS
DC Offset	PASS
Displayed Average Noise Level (DANL)	PASS
Dither	PASS
ADC Interface	PASS
DDS DAC Interface	PASS
Peak Detector	PASS

Copy to Clipboard
Close

Using remote control

- ▶ For a quick check, send `TEST:SENsOr?`.

For each test step, PASS or FAIL is listed.

15.4.1 Interpreting the test results

If all test steps or parts pass, the overall result is PASS. If one test step or a part of it fails, the overall result is FAIL. What you need to do in this case is described in the following.

Power Applied

Checks whether power (signal) is applied at the input.

If the test fails

- ▶ Disconnect the signal source at the input during the selftest.

Operating Voltages

Checks the operating voltages.

If the test fails

1. Disconnect all signal sources and connectors except LAN or USB.
2. Perform the selftest again.
If it fails again, a hardware defect is probable. Contact the service.

Temperatures

Checks the temperature at several measurement points whether they are plausible and whether the limits are met.

Is the ambient temperature OK?

- ▶ Check whether the ambient temperature lies within the range rated in the data sheet of the R&S NRQ6.

If the ambient temperature is higher or lower, adjust the air conditioning of the room or move the test setup into a room with a fitting temperature.

Are the fan openings obstructed?

1. Check whether the fan opening is obstructed.
If they are obstructed, clean them with a vacuum cleaner.
2. Ensure that the pollution degree of the environment does not exceed 2.
3. Ensure that the minimum distance between the fan openings and any object is 10 cm.

Is the fan running?

- ▶ Check whether the fan is running.
If it does not run, contact the service.

Test Generator

The R&S NRQ6 has an integrated signal source to verify the absolute calibration.

If the test fails

1. Check whether a signal is applied at the input. See also "[Power Applied](#)" on page 211.
2. If no signal is applied or if the test step fails again, contact the service.

LO Level

The R&S NRQ6 has mixer-based concept to detect power. It achieves its high stability by controlling the level of the local oscillator (LO) precisely.

If the test fails

- ▶ The uncertainties rated in the data sheet are not granted any more. Contact the service.

DC Offset

Checks the DC offsets of the intermediate frequency (IF) stage.

If the test fails

1. Check whether a signal is applied. An applied signal can influence the accuracy of the measurement.
2. If no signal is applied or if the test step fails again, contact the service.

Displayed Average Noise Level (DANL)

Checks the specified inherent noise of the R&S NRQ6.

If the test fails

1. Check whether a signal is applied.
2. If no signal is applied or if the test step fails again, contact the service.

Dither

The R&S NRQ6 is a highly linear power sensor. To optimize the linearity of the A/D converter, a dither signal is used in certain operating modes. This test step checks whether the dither source works properly.

If the test fails

1. Check whether a signal is applied.
2. If no signal is applied or if the test step fails again, the uncertainties rated in the data sheet are not granted any more. Contact the service.

ADC Interface

Checks the data interface of the A/D converter.

If the test fails

- ▶ Contact the service. This error is a critical.

DDS DAC Interface

Checks the data interface of the A/D converter in the signal synthesis of the local oscillator (LO).

If the test fails

- ▶ Contact the service. This error is a critical.

15.5 Problems during a firmware update

Sensor blinks red after firmware update

The firmware update is described in [Chapter 11, "Firmware update"](#), on page 112.

Firmware update was interrupted

If, for example, a power cut happened during the firmware update, problems can occur.

1. Perform the firmware update again. Sometimes, a further update fixes the problems.
2. If the R&S NRQ6 is not accessible any more, contact the service.

15.6 Cannot establish a LAN connection

If you have problems to establish a peer-to-peer connection as described in [Chapter 3.6.1.4, "Establishing a connection"](#), on page 20, try the following measures:

Troubleshooting for peer-to-peer connections

1. Allow a waiting time, especially if the computer was used in a network before.
2. Check that only the main network adapter is active on the computer. If the computer has more than one network interfaces, explicitly disable all other network interfaces if you plan to utilize a peer-to-peer connection to the R&S NRQ6.
3. Check that the remaining main network adapter has been assigned an IP address starting with 169.254. The IANA (Internet assigned numbers authority) has reserved the range 169.254.0.0 to 169.254.255.255 for the allocation of

automatic private IP addresses (APIPA). Addresses from this range are guaranteed to cause no conflicts with any routable IP address.

4. Try to establish a connection to the R&S NRQ6 with both the default hostname and the hostname extended with `.local`, for example:

```
nrq6-101441  
nrq6-101441.local
```

15.7 Contacting customer support

Technical support – where and when you need it

For quick, expert help with any Rohde & Schwarz product, contact our customer support center. A team of highly qualified engineers provides support and works with you to find a solution to your query on any aspect of the operation, programming or applications of Rohde & Schwarz products.

Contact information

Contact our customer support center at www.rohde-schwarz.com/support, or follow this QR code:



Figure 15-1: QR code to the Rohde & Schwarz support page

16 Transporting

Packing

Use the original packaging material. It consists of antistatic wrap for electrostatic protection and packing material designed for the product.

If you do not have the original packaging, use similar materials that provide the same level of protection. You can also contact your local Rohde & Schwarz service center for advice.

Securing

When moving the product in a vehicle or using transporting equipment, make sure that the product is properly secured. Only use items intended for securing objects.

Transport altitude

Unless otherwise specified in the data sheet, the maximum transport altitude without pressure compensation is 4500 m above sea level.

17 Maintenance, storage and disposal

It is advisable to check the nominal data from time to time.

17.1 Regular checks

If the power sensor is used frequently, check the RF connectors for visible damage - bent inner conductors, broken contact springs and so on. If the RF connectors are damaged, stop using the power sensor. Contact Rohde & Schwarz customer service, see [Chapter 15.7, "Contacting customer support"](#), on page 214.

Checking the integrity of the RF connector

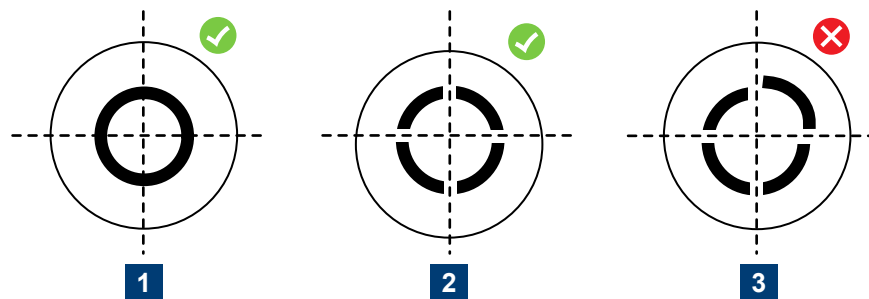

- 1 = Perfectly formed contacts
- 2 = Normal wear
- 3 = Damaged contacts

Checking the concentricity of the RF connector

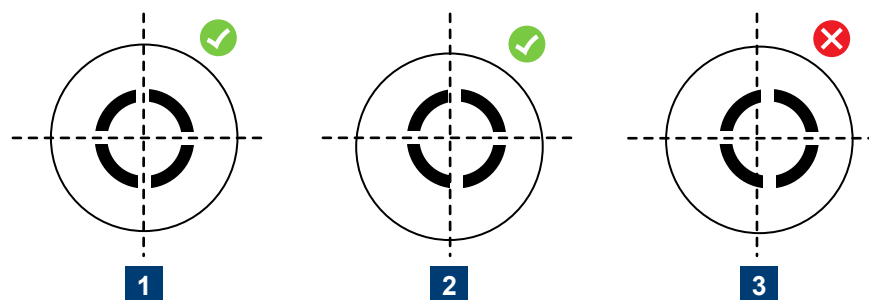

- 1 = Perfectly concentric
- 2 = Slightly off-center
- 3 = Excessively off-center

17.2 Cleaning

1. Disconnect the R&S NRQ6:
 - a) From the DUT.
 - b) From the computer or base unit.
2. Clean the outside of the R&S NRQ6 using a lint-free cloth. You can dampen the cloth with water but keep in mind that the casing is not waterproof. If you use isopropyl alcohol or ethanol instead of water, be careful not to damage the labeling. Do not use cleaning agents that can damage the instrument such as solvents, acids or alkalis.
3. Clean the RF connectors as follows:
 - a) Dislodge any particles using solvent-free compressed air.
 - b) Clean the inside and the connector threads using a foam swab or lint free cloth dampened with isopropyl alcohol or ethanol.

Further information:

- ["To disconnect from the DUT"](#) on page 16

17.3 Storage

Put plastic end caps on the RF connectors to protect them from damage. Protect the power sensor against dust.

Ensure that the environmental conditions, e.g. temperature range and climatic load, meet the values specified in the data sheet.

17.4 Disposal

Rohde & Schwarz is committed to making careful, ecologically sound use of natural resources and minimizing the environmental footprint of our products. Help us by disposing of waste in a way that causes minimum environmental impact.

Disposing electrical and electronic equipment

A product that is labeled as follows cannot be disposed of in normal household waste after it has come to the end of its service life. Even disposal via the municipal collection points for waste electrical and electronic equipment is not permitted.



Figure 17-1: Labeling in line with EU directive WEEE

Rohde & Schwarz has developed a disposal concept for the eco-friendly disposal or recycling of waste material. As a manufacturer, Rohde & Schwarz completely fulfills its obligation to take back and dispose of electrical and electronic waste. Contact your local service representative to dispose of the product.

List of commands

[SENSe<Sensor>:][POWer:][AVG:]APERTure.....	147
[SENSe<Sensor>:][POWer:][AVG:]BUFFer:CLEar.....	133
[SENSe<Sensor>:][POWer:][AVG:]BUFFer:COUNT?.....	133
[SENSe<Sensor>:][POWer:][AVG:]BUFFer:DATA?.....	133
[SENSe<Sensor>:][POWer:][AVG:]BUFFer:SIZE.....	133
[SENSe<Sensor>:][POWer:][AVG:]BUFFer:STATe.....	133
[SENSe<Sensor>:]ACLR:ACHannel:SPACing[:ACHannel]?.....	151
[SENSe<Sensor>:]ACLR:APERture.....	151
[SENSe<Sensor>:]ADJust[:ALL].....	123
[SENSe<Sensor>:]AVERage:COUNT.....	145
[SENSe<Sensor>:]AVERage:RESet.....	145
[SENSe<Sensor>:]AVERage:TCONtrol.....	146
[SENSe<Sensor>:]AVERage:TYPE.....	146
[SENSe<Sensor>:]AVERage[:STATe].....	145
[SENSe<Sensor>:]BANDwidth:INFO?.....	123
[SENSe<Sensor>:]BANDwidth:NOISe?.....	124
[SENSe<Sensor>:]BANDwidth:RESolution.....	124
[SENSe<Sensor>:]BANDwidth:RESolution:CUV?.....	124
[SENSe<Sensor>:]BANDwidth:RESolution:TYPE.....	125
[SENSe<Sensor>:]BANDwidth:RESolution:TYPE:AUTO[:STATe].....	125
[SENSe<Sensor>:]BANDwidth:SRATe.....	125
[SENSe<Sensor>:]BANDwidth:SRATe:CUV?.....	126
[SENSe<Sensor>:]BANDwidth:TYPE.....	146
[SENSe<Sensor>:]BANDwidth:VARiable.....	126
[SENSe<Sensor>:]CORRection:DCYCLe.....	147
[SENSe<Sensor>:]CORRection:DCYCLe:STATe.....	147
[SENSe<Sensor>:]CORRection:OFFSet.....	161
[SENSe<Sensor>:]CORRection:OFFSet:STATe.....	161
[SENSe<Sensor>:]CORRection:SPDeVice<DeVice>:DATA.....	164
[SENSe<Sensor>:]CORRection:SPDeVice<DeVice>:MAXPower.....	165
[SENSe<Sensor>:]CORRection:SPDeVice<DeVice>:MINPower.....	165
[SENSe<Sensor>:]CORRection:SPDeVice<DeVice>:MNEMonic.....	166
[SENSe<Sensor>:]CORRection:SPDeVice<DeVice>:UNLock.....	166
[SENSe<Sensor>:]CORRection:SPDeVice<undef>:CLEar.....	168
[SENSe<Sensor>:]CORRection:SPDeVice<undef>:DELeTe.....	167
[SENSe<Sensor>:]CORRection:SPDeVice<undef>:FLAGs?.....	169
[SENSe<Sensor>:]CORRection:SPDeVice<undef>:INDeX:DEFault.....	169
[SENSe<Sensor>:]CORRection:SPDeVice<undef>:LIST?.....	167
[SENSe<Sensor>:]CORRection:SPDeVice<undef>:SELeCt.....	167
[SENSe<Sensor>:]CORRection:SPDeVice<undef>:SEt.....	169
[SENSe<Sensor>:]CORRection:SPDeVice<undef>:STATe.....	168
[SENSe<Sensor>:]FILTer:DCReJect:FCORner.....	162
[SENSe<Sensor>:]FILTer:DCReJect:FCORner:CUV?.....	162
[SENSe<Sensor>:]FILTer:DCReJect[:STATe].....	162
[SENSe<Sensor>:]FREQuency:CONVerSion:MIXer:IF:SIDeband.....	172
[SENSe<Sensor>:]FREQuency:CONVerSion:MIXer:IF:SIDeband:AUTO[:STATe].....	172
[SENSe<Sensor>:]FREQuency:CONVerSion:MIXer:IF[:CUV]?.....	172

[SENSe<Sensor>:]FREQuency:CONVersion:MIXer:LO:OUTPut[:STATe].....	173
[SENSe<Sensor>:]FREQuency:CONVersion:MIXer:LO:SOURce.....	173
[SENSe<Sensor>:]FREQuency:CONVersion:MIXer:LO[:CUV]?.....	173
[SENSe<Sensor>:]FREQuency:TRACk.....	174
[SENSe<Sensor>:]FREQuency:TRACk:CUV[:STATe]?.....	174
[SENSe<Sensor>:]FREQuency:TRACk:FREQuency?.....	174
[SENSe<Sensor>:]FREQuency[:CENTer].....	126
[SENSe<Sensor>:]FUNCTion.....	127
[SENSe<Sensor>:]INPut:ATTenuation.....	126
[SENSe<Sensor>:]INPut:ATTenuation:AUTO.....	127
[SENSe<Sensor>:]POWer:NCORrection[:STATe].....	162
[SENSe<Sensor>:]ROSCillator:PASSthrough.....	175
[SENSe<Sensor>:]ROSCillator:REFio:FREQuency.....	175
[SENSe<Sensor>:]ROSCillator:REFio:OUTPut[:STATe].....	176
[SENSe<Sensor>:]ROSCillator:SOURce.....	176
[SENSe<Sensor>:]SAMPLing:CLKio:OUTPut[:STATe].....	176
[SENSe<Sensor>:]SGAMma:CORRection:STATe.....	171
[SENSe<Sensor>:]SGAMma:MAGNitude.....	171
[SENSe<Sensor>:]SGAMma:PHASe.....	171
[SENSe<Sensor>:]SPECTrum:FFT:FREQuency:START?.....	151
[SENSe<Sensor>:]SPECTrum:FFT:FREQuency:STEP?.....	152
[SENSe<Sensor>:]SPECTrum:FFT:POINTs.....	152
[SENSe<Sensor>:]TRACe:AVERAge:COUNT.....	148
[SENSe<Sensor>:]TRACe:AVERAge:TCONTROL.....	148
[SENSe<Sensor>:]TRACe:AVERAge[:STATe].....	148
[SENSe<Sensor>:]TRACe:DATA?.....	134
[SENSe<Sensor>:]TRACe:IQ:DATA:FORMat.....	138
[SENSe<Sensor>:]TRACe:IQ:DATA?.....	136
[SENSe<Sensor>:]TRACe:IQ:RLEnGth.....	152
[SENSe<Sensor>:]TRACe:IQ:SYNC:TYPE.....	153
[SENSe<Sensor>:]TRACe:OFFSet:TIME.....	149
[SENSe<Sensor>:]TRACe:POINTs.....	150
[SENSe<Sensor>:]TRACe:RLEnGth[:CUV]?.....	149
[SENSe<Sensor>:]TRACe:SRATe[:CUV]?.....	153
[SENSe<Sensor>:]TRACe:TIME.....	150
[SENSe<Sensor>:]TRACe:TIME:AUTO.....	150
*CLS.....	119
*ESE.....	120
*ESR?.....	120
*IDN?.....	120
*IST?.....	120
*OPC.....	120
*OPT?.....	121
*PRE.....	121
*RCL.....	121
*RST.....	121
*SAV.....	122
*SRE.....	122
*STB?.....	122
*TRG.....	122

*TST?	122
*WAI	123
ABORT	128
CALCulate:FEED	130
CALibration:DATA	139
CALibration:DATA:LENGth?	140
CALibration:DATA:PATH<Path>:ABSolute	140
CALibration:FREQUency:LIMits	140
CALibration:PROTOcol?	141
CALibration:RECalculate	141
CALibration:RESTore	142
CALibration:SAVE	142
CALibration:UNLock	142
CALibration<Channel>:IQOffset[:AUTO]	141
CALibration<Channel>:ZERO:AUTO	142
FETCH<Sensor>:ARRAy[:POWer][:AVG]?	132
FETCH<Sensor>[:SCALAr][:POWer][:AVG]?	131
FORMat:BORDER	136
FORMat:SREGister	137
FORMat[:DATA]	137
INITiate:ALL	129
INITiate:CONTInuous	128
INITiate[:IMMediate]	129
STATus:DEVice:CONDition?	190
STATus:DEVice:ENABle	190
STATus:DEVice:NTRansition	191
STATus:DEVice:PTRansition	191
STATus:DEVice[:EVENT]?	190
STATus:OPERation:CALibrating:CONDition?	190
STATus:OPERation:CALibrating:ENABle	190
STATus:OPERation:CALibrating:NTRansition	191
STATus:OPERation:CALibrating:PTRansition	191
STATus:OPERation:CALibrating[:SUMMary][:EVENT]?	190
STATus:OPERation:CONDition?	190
STATus:OPERation:ENABle	190
STATus:OPERation:LLFail:CONDition?	190
STATus:OPERation:LLFail:ENABle	190
STATus:OPERation:LLFail:NTRansition	191
STATus:OPERation:LLFail:PTRansition	191
STATus:OPERation:LLFail[:SUMMary][:EVENT]?	190
STATus:OPERation:MEASuring:CONDition?	190
STATus:OPERation:MEASuring:ENABle	190
STATus:OPERation:MEASuring:NTRansition	191
STATus:OPERation:MEASuring:PTRansition	191
STATus:OPERation:MEASuring[:SUMMary][:EVENT]?	190
STATus:OPERation:NTRansition	191
STATus:OPERation:PTRansition	191
STATus:OPERation:SENSe:CONDition?	190
STATus:OPERation:SENSe:ENABle	191
STATus:OPERation:SENSe:NTRansition	191

STATus:OPERation:SENSe:PTRansition.....	191
STATus:OPERation:SENSe[:SUMMary][:EVENT]?	190
STATus:OPERation:TRIGger:CONDition?	190
STATus:OPERation:TRIGger:ENABle.....	191
STATus:OPERation:TRIGger:NTRansition.....	191
STATus:OPERation:TRIGger:PTRansition.....	191
STATus:OPERation:TRIGger[:SUMMary][:EVENT]?	190
STATus:OPERation:ULFail:CONDition?	190
STATus:OPERation:ULFail:ENABle.....	191
STATus:OPERation:ULFail:NTRansition.....	191
STATus:OPERation:ULFail:PTRansition.....	191
STATus:OPERation:ULFail[:SUMMary][:EVENT]?	190
STATus:OPERation[:EVENT]?	190
STATus:PRESet.....	189
STATus:QUEStionable:CALibration:CONDition?	190
STATus:QUEStionable:CALibration:ENABle.....	191
STATus:QUEStionable:CALibration:NTRansition.....	191
STATus:QUEStionable:CALibration:PTRansition.....	191
STATus:QUEStionable:CALibration[:SUMMary][:EVENT]?	190
STATus:QUEStionable:CONDition?	190
STATus:QUEStionable:ENABle.....	191
STATus:QUEStionable:NTRansition.....	191
STATus:QUEStionable:POWer:CONDition?	190
STATus:QUEStionable:POWer:ENABle.....	191
STATus:QUEStionable:POWer:NTRansition.....	191
STATus:QUEStionable:POWer:PTRansition.....	191
STATus:QUEStionable:POWer[:SUMMary][:EVENT]?	190
STATus:QUEStionable:PTRansition.....	191
STATus:QUEStionable:WINDow:CONDition?	190
STATus:QUEStionable:WINDow:ENABle.....	191
STATus:QUEStionable:WINDow:NTRansition.....	191
STATus:QUEStionable:WINDow:PTRansition.....	191
STATus:QUEStionable:WINDow[:SUMMary][:EVENT]?	190
STATus:QUEStionable[:EVENT]?	190
STATus:QUEue[:NEXT]?	189
SYSTem:COMMunicate:NETWork:IPADdress.....	177
SYSTem:COMMunicate:NETWork:IPADdress:GATeway.....	178
SYSTem:COMMunicate:NETWork:IPADdress:INFO?	178
SYSTem:COMMunicate:NETWork:IPADdress:MODE.....	178
SYSTem:COMMunicate:NETWork:IPADdress:SUBNet:MASK.....	178
SYSTem:COMMunicate:NETWork:RESet.....	179
SYSTem:COMMunicate:NETWork:REStart.....	179
SYSTem:COMMunicate:NETWork:STATus?	179
SYSTem:COMMunicate:NETWork[:COMMOn]:DOMain.....	179
SYSTem:COMMunicate:NETWork[:COMMOn]:HOSTname.....	179
SYSTem:COMMunicate:PSErvoing:BCLock.....	180
SYSTem:COMMunicate:PSErvoing:TPATtern.....	180
SYSTem:DFPRint<Channel>?	180
SYSTem:ERRor:ALL?	181
SYSTem:ERRor:CODE:ALL?	181

SYSTem:ERRor:CODE[:NEXT]?	181
SYSTem:ERRor:COUNT?	181
SYSTem:ERRor[:NEXT]?	182
SYSTem:FWUPdate	182
SYSTem:FWUPdate:STATus?	182
SYSTem:HELP:HEADers?	183
SYSTem:HELP:SYNTax:ALL?	183
SYSTem:HELP:SYNTax?	183
SYSTem:INFO?	183
SYSTem:INITialize	184
SYSTem:LANGuage	185
SYSTem:LED:COLor	185
SYSTem:LED:MODE	185
SYSTem:LICense:KEY	186
SYSTem:LICense:XML	186
SYSTem:MINPower:UNIT	187
SYSTem:MINPower?	186
SYSTem:PARAmeters:DELTA?	187
SYSTem:PARAmeters?	187
SYSTem:PRESet	187
SYSTem:REBoot	187
SYSTem:REStart	188
SYSTem:SERRor:LIST:ALL?	188
SYSTem:SERRor:LIST[:NEXT]?	188
SYSTem:SERRor?	188
SYSTem:VERsion?	189
SYSTem[:SENSor]:NAME	188
TEST:SENSor?	143
TRIGger:ATRigger:DELay	154
TRIGger:ATRigger:EXECuted?	154
TRIGger:ATRigger[:STATe]	154
TRIGger:COUNt	155
TRIGger:DELay	155
TRIGger:DTIME	155
TRIGger:EXTErnal<2...2>:IMPedance	155
TRIGger:HOLDoff	156
TRIGger:HYSteresis	156
TRIGger:IMMediate	156
TRIGger:JITTer:METhod	157
TRIGger:JITTer:METhod:CUV?	157
TRIGger:JITTer?	157
TRIGger:LEVel	158
TRIGger:LEVel:AUTO	158
TRIGger:LEVel:UNIT	158
TRIGger:SENDER:PORT	158
TRIGger:SENDER:STATe	159
TRIGger:SLOPe	159
TRIGger:SOURce	159
TRIGger:SYNC:PORT	160
TRIGger:SYNC:STATe	160

UNIT:POWer..... 138

Index

A

ACLR mode	70
Remote control	151
Result display	71
Settings	70
Aperture time	
Measurement duration	43
Application cards	12
Application notes	12
Application sheets	12
Attenuation	56, 59
Automatic settings	49, 51
Autoset	49, 51, 57
Averaging	
Measurement duration	43
Averaging domains	61

B

Band limited measurement	
MSR	51
Bandwidth setting	58
Brochures	12
Browser-based user interface	34
Chart toolbar	37
Main dialog	35
Parameter	38
Tooltips	37

C

Calibration	
Remote control	138
CD-ROM	11
Chart toolbar	37
Checking	14
Cleaning	217
Clock source configuration	104
Common command	119
Computer	
Connecting	17
LAN connection	17
Simple USB connection	23
USB sensor hub	24
Connecting	
Computer	17, 23, 24
Power supply	16
R&S NRX	17
RF	15
Connector	
Host interface	30
LAN	28
Local oscillator	31
Reference clock	30
RF	27
Sampling clock	31
Trigger	30
Continuous average mode	61
Averaging domains	61
Remote control	144
Result display	65
Settings	63

Control

Measurement	82
Controlling host	
Computer using LAN	17
Computer using USB	22
R&S NRX	25
Conversion frequency	104
Correction	
DC zeroing	98
External losses	96
IF path	96
Noise	95
Remote control	160
RF path	94
S-gamma	96
S-parameter	96
Settings	94
Zero calibration	95
Customer support	214

D

Data sheets	12
DC rejection	96
Remote control	161
DC zeroing	98
ACLR mode	72
Device status register	198
Diagnostics	
Selftest	210
Disconnecting	
R&S NRX	26
RF	16
USB host	24
Download	
R&S NRP Toolkit	32
Dropout time	
Trigger	89
Duration	
Aperture time	43
Averaging	43
Filter settling time	43
DUT	
Connecting	15
Disconnecting	15

E

EMC class	14
Enable register	201
Ending measurement	43
Remote control	128
Error	
Potential sources	46
Querying	207
Error messages	207, 208
ESE	201
ESR	201
Ethernet interface	
Remote control	194
External signal analysis	73

F

Fan openings	31
Filter	
Bandwidth	54
Characteristics	52
Control	58
DC reject	96
Shape	52
Filter settling time	
Measurement duration	43
Filter type	
Automatic selection	53
Gaussian	53
Rectangular	52
Firmware update	34, 112
Firmware Update for NRP Family	113
Over LAN	113
Over USB	115
Preparing	112
Problems	213
Remote control	116
Web user interface	112
Frequency configuration	50
Frequency tracker	50
Narrowband measurements	51
Frequency setting	58
Spurious response frequencies	46
Frequency tracker	50
Functional principle	42

G

Getting started	11
-----------------------	----

H

HiSLIP	195
Hold-off time	
Trigger	90
Host interface	30
Hostname	21

I

I/Q data interface	73
I/Q trace mode	73
Remote control	151, 152
Sample rate	77
Settings	77
IF spectrum	57, 73, 136
Input attenuation	59
Installation	
Firmware	112
Installing	
License key	107
Instrument security procedures	12
Intended use	9
Interface	
Ethernet	28, 194
LAN	194
IP address	22

J

Jitter	
Trigger	90

K

Key Facts	13
-----------------	----

L

Labels	10
LAN	
Connecting	16
LAN connection	
Hostname	21
IP address	22
Non-PoE+ Ethernet switch	19
PoE+ Ethernet switch	18
PoE+ injector	19, 20
Problems	213
Setup	20
LAN connector	28
LAN interface	
Remote control	194
LED	
Network status	29
Power status	29
Status	28
Level correction	96
License key	107, 110
LO leakage	47
Local area network (LAN)	28
Local oscillator connector	31
Local oscillator signal	102

M

Main dialog	35
Top pane	49
Maintenance	216
Cleaning	217
Regular checks	216
Manual settings	57
Measurement	
Bias	62
Configuration	82
Control	82
Duration	43
Ending	43, 128
Modulated signals	63
Noise	62
Potential sources of error	46
Procedure in principle	42
Signal type accounting	62
Starting	35, 42, 128
Test signal adaption	49
Measurement mode	61
ACLR	70
Continuous average	61
I/Q trace	73
IF spectrum	73
Remote control	127, 144
Trace	66
Measurement results	
ACLR	135
Continuous average	132
Controlling	82
I/Q	136
IF spectrum	136
Improving	44

Remote control	129
Trace	134
Mixer	
Local oscillator signal	102
Remote control	172
Settings	101
Modulated signals	63
Multistandard radio base station	51
N	
Network status LED	29
Noise	44
Noise correction	95
Remote control	162
Noise power	56
Non-PoE+ Ethernet switch	19
O	
Offset	
Level	96
Offset correction	
Remote control	161
Open source acknowledgment (OSA)	12
Operating concepts	32
Browser-based user interface	34
R&S NRP Toolkit	32
R&S NRX	39
Operating conditions	14
Operation status registers	202
Option	
External signal analysis	73
Phase coherent measurements	74
Power servoing	80
R&S NRQ6-K1	73
R&S NRQ6-K2	80
R&S NRQ6-K3	74
Option management	107
P	
Parameter	
Changing	38
Parameters	
ACLR mode	70
Continuous average mode	63
Correction	99
I/Q trace mode	77
Mixer	102
Sensor	105
System	108
Top pane	57
Trace mode	66
Trigger	91
Phase coherent measurements	74
PoE+	28
PoE+ Ethernet switch	18
PoE+ injector	19, 20
Potential sources of error	46
LO leakage	47
Spurious response frequencies	46
Power servoing	80
Power sourcing equipment	
PoE+	28
Power status LED	29
Power supply	
Connecting	16
Preparing for use	14
Preview	57
Procedure in principle	42
Q	
Questionable status registers	199
R	
R&S NRP Toolkit	32
Components for Windows-based systems	33
Firmware update	34
Installation under Windows	33
System requirements	32
Versions	32
R&S NRP-Z5	24
R&S NRQ6-K1	
I/Q data interface	73
R&S NRX	39
Connecting	17, 26
Disconnecting	26
Setup	25
Reference clock	104
Connector	30
Reference frequencies	
Synchronization	51
Regular checks	216
Regulatory information	9
Release notes	12
Remote control	40
Basics	193
Commands	118
Common commands	119
Conventions	118
Ethernet interface	194
Interfaces	193
LAN interface	194
Measurement settings	144
Programming examples	192
Protocols	193
USB interface	193
VISA resource strings	195
Resolution bandwidth filter	52
Resource string	
HiSLIP	195
Socket	195
VISA	195
VXI-11	195
Result	
Configuring	136
Retrieving	129
Result display	
ACLR mode	71
Continuous average mode	65
Trace mode	68
Results	
Implausible	209
RF connector	15, 27
RF input attenuation	56
RSU file	112
S	
S-gamma	96

- S-parameter 96
 - S-parameter correction
 - Remote control 163
 - State 60
 - Safety information 9
 - Safety instructions 9, 12
 - Sample rate 77
 - Sampling clock 104
 - Connector 31
 - Sampling rate 77
 - Self-adjustment 101
 - Remote control 138
 - Selftest 210
 - Remote control 143
 - Sender usage
 - Trigger 90
 - Sensor
 - Clock source 104
 - Settings 104
 - Sensor settings
 - Remote control 174
 - Serial number 10
 - Settings
 - Automatic 49, 51
 - Correction 94
 - Manual 57
 - Measurement 82
 - Mixer 101
 - See also parameters 57
 - Sensor 104
 - System 107
 - Setup
 - Computer 17, 22
 - R&S NRX 25
 - Signal check 57
 - Signal type 62
 - Simple USB connection 23
 - Socket 195
 - Solving errors 208
 - Sources
 - Trigger 88
 - Standard event status register 201
 - Starting measurement 35, 42
 - Remote control 128
 - Status
 - Information 28, 207
 - LED 28
 - Status register
 - CONDition part 190
 - Device status register 198
 - ENABLE part 190
 - Enable register 201
 - EVENT part 190
 - General commands 189
 - Hierarchy 196
 - NTRansition part 191
 - Operation calibrating status register 203
 - Operation measuring status register 204
 - Operation status register 202
 - Operation trigger status register 205
 - PTRansition part 191
 - Questionable calibration status register 200
 - Questionable power status register 200
 - Questionable status register 199
 - Remote control 189
 - Standard event status register 201
 - Synchronization
 - Reference frequencies 51
 - System
 - Settings 107
 - System configuration
 - Remote control 176
- ## T
- Target audience 9
 - Termination control 82
 - Test setup 15
 - Test signal
 - Preview 57
 - Properties 49, 123
 - Toolbar
 - Chart 37
 - Tooltips 37
 - Trace mode 66
 - Remote control 147
 - Result display 68
 - Settings 66
 - Transporting 215
 - Trigger 88
 - Dropout time 89
 - Hold-off time 90
 - Jitter 90
 - Remote control 153
 - Sender usage 90
 - Sources 88
 - States 88
 - Trigger connector 30
 - Troubleshooting 207
 - Error messages 207, 208
 - Errors 207
 - Firmware update 213
 - Implausible results 209
 - LAN connection problems 213
 - Selftest 210
 - Status information 207
 - Tutorials 12
- ## U
- Units 119
 - Unpacking 14
 - Update file 112
 - USB connection
 - Simple 23
 - USB sensor hub 24
 - USB interface
 - Remote control 193
 - USB resource string 194
 - USB sensor hub 24
 - USBTMC protocol 194
 - User manual 11
- ## V
- VISA 195
 - VXI-11 195
- ## W
- Warning message 10

Web user interface	34
Chart toolbar	37
Main dialog	35, 49
Parameter	38
Tooltips	37
White papers	12

Z

Zero calibration	95
Zero configuration networking	20
Zeroing	101
DC	98
Remote control	138