

# R&S®NRPM OTA Power Measurement Solution Manual



1425866302

Version 08

**ROHDE & SCHWARZ**

Make ideas real



This document describes the R&S®NRPM OTA Power Measurement Solution, including the following components:

- R&S®NRPM3N Three-channel sensor module LAN, 1425.8592.02
- R&S®NRPM3 Three-channel sensor module, 1425.8563.02
- R&S®NRPM-A90 Single-polarized antenna module, 1426.7760.02/.03/.04/.05
- R&S®NRPM-A90D Dual-polarized antenna module, 1426.7777.02/.03/.04/.05
- R&S®NRPM-ZD3 Feedthrough module, 1425.8786.02
- R&S®NRPM-Z3 Three-channel interface module, 1426.7602.02

© 2022 Rohde & Schwarz GmbH & Co. KG  
Muehldorfstr. 15, 81671 Muenchen, Germany  
Phone: +49 89 41 29 - 0

Email: [info@rohde-schwarz.com](mailto:info@rohde-schwarz.com)

Internet: [www.rohde-schwarz.com](http://www.rohde-schwarz.com)

Subject to change – data without tolerance limits is not binding.

R&S® is a registered trademark of Rohde & Schwarz GmbH & Co. KG.

All other trademarks are the properties of their respective owners.

1425.8663.02 | Version 08 | R&S®NRPM

Throughout this manual, products from Rohde & Schwarz are indicated without the ® symbol, e.g. R&S®NRPM is abbreviated as R&S NRPM. Microsoft®Windows® is abbreviated as MS Windows, macOS® is abbreviated as macOS and Linux® is abbreviated as Linux.

# Contents

<b>1 Safety and regulatory information.....</b>	<b>9</b>
1.1 Safety instructions.....	9
1.2 Labels on the product.....	10
1.3 Warning messages in the documentation.....	11
<b>2 Welcome to the R&amp;S NRPM OTA power measurement solution.....</b>	<b>12</b>
2.1 Key features.....	12
2.2 About the R&S NRPM OTA power measurement solution.....	13
<b>3 Documentation overview.....</b>	<b>15</b>
3.1 User manual.....	15
3.2 Tutorials.....	15
3.3 Instrument security procedures.....	15
3.4 Basic safety instructions.....	15
3.5 Data sheets and brochures.....	16
3.6 Release notes and open source acknowledgment (OSA).....	16
3.6.1 Application notes, application cards, white papers, etc.....	16
<b>4 Preparing for use.....</b>	<b>17</b>
4.1 Unpacking and checking.....	17
4.2 Choosing the operating site.....	17
4.3 Considerations for test setup.....	18
4.4 Powering the R&S NRPM3(N) sensor module.....	20
4.5 Hardware and software requirements.....	20
4.5.1 Hardware.....	20
4.5.2 Mandatory software.....	21
4.5.3 Optional software.....	22

<b>4.6</b>	<b>Installing the software application and drivers.....</b>	<b>23</b>
4.6.1	VISA driver installation.....	24
4.6.2	R&S NRP Toolkit installation.....	24
4.6.3	R&S Power Viewer installation.....	27
<b>5</b>	<b>R&amp;S NRPM tour.....</b>	<b>29</b>
5.1	R&S NRPM3(N) sensor modules.....	29
5.2	R&S NRPM-A90 and R&S NRPM-A90D antenna modules.....	32
5.3	R&S NRPM-ZD3 feedthrough module.....	34
5.4	R&S NRPM-Z3 interface module.....	36
5.5	R&S NRPM-Z3 connected to the R&S NRPM3.....	37
<b>6</b>	<b>Setting up a measurement.....</b>	<b>38</b>
6.1	Test setup examples.....	38
6.2	R&S CMQ200 shielding cube.....	42
6.3	Connecting an R&S NRPM OTA power measurement.....	43
6.3.1	Connecting the RF frontend.....	44
6.3.2	Connecting to the controller PC.....	46
6.3.3	Using the USB connection.....	47
6.3.4	Using the LAN connection.....	50
6.3.5	Connecting to the network.....	54
6.4	Starting the measurement.....	57
<b>7</b>	<b>Performing measurements.....</b>	<b>58</b>
7.1	Sensor module readings.....	58
7.2	Measurement applications.....	58
7.2.1	Using R&S Power Viewer.....	59
7.2.2	Using the web browser-based user interface.....	66
<b>8</b>	<b>Firmware update.....</b>	<b>83</b>

<b>8.1 Hardware and software requirements.....</b>	<b>83</b>
<b>8.2 Updating the firmware.....</b>	<b>83</b>
8.2.1 Using the firmware update for R&S NRP family program.....	84
8.2.2 Using the web browser-based user interface.....	86
8.2.3 Using remote control.....	87
<b>9 Network and remote operation.....</b>	<b>89</b>
<b>9.1 Remote control interfaces and protocols.....</b>	<b>89</b>
9.1.1 USB interface.....	90
9.1.2 Ethernet interface.....	91
<b>9.2 Status reporting system.....</b>	<b>95</b>
9.2.1 Hierarchy of the status registers.....	95
9.2.2 Structure of an SCPI status register.....	97
9.2.3 Status byte (STB) and service request enable register (SRE).....	99
9.2.4 IST flag and parallel poll enable register (PPE).....	100
9.2.5 Device status register.....	101
9.2.6 Questionable status register.....	102
9.2.7 Standard event status and enable register (ESR, ESE).....	104
9.2.8 Operation status register.....	105
<b>10 Remote control commands.....</b>	<b>112</b>
<b>10.1 Conventions used in SCPI command descriptions.....</b>	<b>112</b>
<b>10.2 Notations.....</b>	<b>113</b>
<b>10.3 Common commands.....</b>	<b>114</b>
<b>10.4 Configuring the general functions.....</b>	<b>120</b>
10.4.1 Configuring the system.....	120
10.4.2 Handling of available antenna modules.....	134
10.4.3 Selecting the reference source.....	135
10.4.4 Setting the power unit.....	135

10.4.5	Setting the result format.....	136
<b>10.5</b>	<b>Controlling the measurement.....</b>	<b>137</b>
10.5.1	Triggering.....	137
10.5.2	Controlling the measurement results.....	141
10.5.3	Interplay of the controlling mechanisms.....	142
<b>10.6</b>	<b>Selecting a measurement mode and retrieving results.....</b>	<b>148</b>
<b>10.7</b>	<b>Configuring the measurement modes.....</b>	<b>153</b>
10.7.1	Configuring a continuous average measurement.....	153
10.7.2	Configuring a list mode measurement.....	156
10.7.3	Configuring a trace measurement.....	157
<b>10.8</b>	<b>Configuring basic measurement parameters.....</b>	<b>165</b>
10.8.1	Configuring averaging.....	165
10.8.2	Setting the frequency.....	168
10.8.3	Configuring corrections.....	168
<b>10.9</b>	<b>Starting and ending a measurement.....</b>	<b>170</b>
<b>10.10</b>	<b>Configuring the trigger.....</b>	<b>172</b>
<b>10.11</b>	<b>Using the status register.....</b>	<b>180</b>
10.11.1	General status register commands.....	181
10.11.2	Reading out the CONDition part.....	181
10.11.3	Reading out the EVENT part.....	182
10.11.4	Controlling the ENABLE part.....	182
10.11.5	Controlling the negative transition part.....	183
10.11.6	Controlling the positive transition part.....	184
<b>10.12</b>	<b>Testing the R&amp;S NRPM OTA Power Measurement Solution.....</b>	<b>184</b>
<b>10.13</b>	<b>Calibrating/zeroing the R&amp;S NRPM3(N) sensor module.....</b>	<b>185</b>
<b>11</b>	<b>Programming examples.....</b>	<b>187</b>
11.1	Performing a simple measurement.....	187

11.2	Performing measurements in continuous average mode.....	187
11.3	Performing measurements in list mode.....	192
11.4	Performing measurements in trace mode.....	199
<b>12</b>	<b>Troubleshooting.....</b>	<b>203</b>
12.1	Displaying status information.....	203
12.2	Performing a selftest.....	203
12.3	Problems during a firmware update.....	204
12.4	Cannot establish a LAN connection.....	205
12.4.1	Components of the R&S NRP Toolkit.....	205
12.5	Replacing antenna cables.....	206
12.5.1	Spare parts and recommended tools.....	206
12.5.2	Cable replacement.....	207
12.6	Contacting customer support.....	210
<b>13</b>	<b>Transporting.....</b>	<b>211</b>
<b>14</b>	<b>Maintenance, storage and disposal.....</b>	<b>212</b>
14.1	Cleaning.....	212
14.2	Storage.....	212
14.3	Disposal.....	213
	<b>Glossary: List of used terms and abbreviations.....</b>	<b>214</b>
	<b>List of commands.....</b>	<b>218</b>
	<b>Index.....</b>	<b>223</b>





# 1 Safety and regulatory information

The product documentation helps you use the product safely and efficiently. Follow the instructions provided here and in the following chapters.

## Intended use

The R&S NRPM OTA power measurement solution is intended for accurate power measurements in production, R&D and calibration labs, and for installation and maintenance tasks. Observe the operating conditions and performance limits stated in the data sheet.

## Target audience

The target audience is developers and technicians. The required skills and experience in power measurements depend on the used operating concept.

The R&S NRPM OTA power measurement solution is designed for use in anechoic environments as RF shielded boxes or benchtop applications in RF test chambers. You can use it for Over-the-Air (OTA) beamforming verification in 5G, WLAN IEEE 802.11ad and IEEE 802.11ay and the calibration of the transmit antenna output power.

## Where do I find safety information?

Safety information is part of the product documentation. It warns you of potential dangers and gives instructions on how to prevent personal injury or damage caused by dangerous situations. Safety information is provided as follows:

- In [Chapter 1.1, "Safety instructions"](#), on page 9. The same information is provided in many languages as printed "Safety Instructions". The printed "Safety Instructions" are delivered with the product.
- Throughout the documentation, safety instructions are provided when you need to take care during setup or operation.

## 1.1 Safety instructions

Products from the Rohde & Schwarz group of companies are manufactured according to the highest technical standards. To use the products safely, follow

the instructions provided here and in the product documentation. Keep the product documentation nearby and offer it to other users.

Use the product only for its intended use and within its performance limits. Intended use and limits are described in the product documentation such as the data sheet, manuals and the printed "Safety Instructions". If you are unsure about the appropriate use, contact Rohde & Schwarz customer service.

Using the product requires specialists or specially trained personnel. These users also need sound knowledge of at least one of the languages in which the user interfaces and the product documentation are available.

Reconfigure or adjust the product only as described in the product documentation or the data sheet. Any other modifications can affect safety and are not permitted.

Never open the casing of the product. Only service personnel authorized by Rohde & Schwarz are allowed to repair the product. If any part of the product is damaged or broken, stop using the product. Contact Rohde & Schwarz customer service at <https://www.rohde-schwarz.com/support>.

## Operating the product

Only use the product indoors. The product casing is not waterproof.

Observe the ambient conditions such as altitude, operating temperature and climatic loads; see the data sheet.

## Meaning of safety labels

Safety labels on the product warn against potential hazards.

	Potential hazard Read the product documentation to avoid personal injury or product damage.
---	--

## 1.2 Labels on the product

Labels on the product inform about:

- Personal safety  
See "[Meaning of safety labels](#)" on page 10.
- Environment safety  
See [Table 1-1](#).

## Warning messages in the documentation

- Identification of the product  
See [Chapter 6.3.5.1, "Using hostnames"](#), on page 55.
- Sensitive components  
[Table 1-2](#)

**Table 1-1: Labels regarding environment safety**

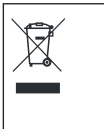
	Labeling in line with EN 50419 for disposal of electrical and electronic equipment after the product has come to the end of its service life. For more information, see " <a href="#">Disposing electrical and electronic equipment</a> " on page 213.
---	---

**Table 1-2: Labels regarding sensitive components**

	Electrostatically sensitive components Indicates sensitivity to touch. Follow the instructions in the product documentation to avoid product damage. See " <a href="#">To prevent antenna damage</a> " on page 18.
---	---

## 1.3 Warning messages in the documentation

A warning message points out a risk or danger that you need to be aware of. The signal word indicates the severity of the safety hazard and how likely it will occur if you do not follow the safety precautions.

### NOTICE

Potential risks of damage. Could result in damage to the supported product or to other property.

## 2 Welcome to the R&S NRPM OTA power measurement solution

Introduces the R&S NRPM OTA power measurement solution.

### 2.1 Key features

The R&S NRPM OTA power measurement solution is designed to calibrate the transmit antenna output power and test the beamforming function over the air. Applications are in high frequency bands, used in modern high performance wireless system standards, e.g. 5G NR, IEE802.11ad and IEEE802.11ay.

Providing measurements of radiated RF power, the R&S NRPM OTA power measurement solution features:

- Single and dual polarized receiver antenna modules with integrated diode detector
- R&S NRPM3(N) sensor module for readings of receiver antenna modules
- **OTA** power measurements with up to three antenna modules per R&S NRPM sensor module
- Ethernet and high speed host USB communication interfaces
- Mode for processing frequency lists for short settling times and fast measuring of predefined random frequency points
- High sensitivity
- Fully calibrated system with specified system uncertainty
- Low-reflection antenna module
- Wide range of supported operating systems
- Easy operation with PC measurement applications, or remotely with SCPI commands

For detailed specification, refer to the data sheet.

## 2.2 About the R&S NRPM OTA power measurement solution

The power measurement solution consists of antenna modules, a three-channel sensor module, and interface modules for connecting the antenna modules to the sensor module. A PC measurement application demonstrates the use of the OTA power measurement solution.

The R&S NRPM3 sensor modules provide a high-speed USB interface that constitutes both, the communication port and the power supply connection. The R&S NRPM3N LAN sensor module adds a Gigabit Ethernet interface with Power-over-Ethernet (PoE) power supply.

The single or dual-polarized antenna modules (R&S NRPM-A90, R&S NRPM-A90D) are usually installed within an [anechoic chamber](#), that can be:

- An [RF shielded box](#), e.g. the R&S CMQ200.

The antenna modules are positioned inside the RF shielded box, the sensor module is outside. The sensor module is connected by the feedthrough module R&S NRPM-ZD3 that provides the interface for up to three antenna modules.

Especially designed for use with the R&S CMQ200, you can install up to six of the feedthrough modules. An antenna ring inside the R&S CMQ200 allows you to position and align the antenna modules flexibly according to the application.

- An [RF test chamber](#) of larger dimensions.

The antenna modules and the sensor module are positioned inside the RF test chamber. The interface module R&S NRPM-Z3, directly connected to the sensor module provides the interface for up to three antenna modules.

With the single and dual polarized antenna modules (R&S NRPM-A90, R&S NRPM-A90D), you can calibrate the DUT (transmit antenna) output power and test the beamforming function.

The R&S NRPM measurement is controlled by an arbitrary user-definable measurement application. For a quick startup, Rohde & Schwarz provides the free interactive application R&S Power Viewer, which supports multiple sensor modules in the measurement modes "Continuous Average" and "Trace".

As an alternative way to operate an R&S NRPM3N sensor module, you can use the browser based web browser-based user interface.

### About the R&S NRPM OTA power measurement solution

For communication over the USB with the standardized protocol [USBTMC](#), the drivers and [APIs](#) are provided for the operating systems Linux, Mac OS X, MS Windows. It is required that you install a [VISA](#) driver on the host operating system, to use the I/O services provided by this standardized software interface library.

The sensor module supports SCPI remote control, e.g. to automate a measurement with a scripting environment.

## 3 Documentation overview

This section provides an overview of the R&S NRPM user documentation. Unless specified otherwise, you find the latest versions of the documents on the product page at: [www.rohde-schwarz.com/manual/nrpm](http://www.rohde-schwarz.com/manual/nrpm).

### 3.1 User manual

Introduces the R&S NRPM and describes how to set up and start working with the product. The manual includes general information, and the typical measurement application with programming examples. The sensor module specific functions, and an introduction to remote control and a complete description of the remote control commands are described.

A printed version is delivered with the R&S NRPM OTA Power Measurement Solution.

### 3.2 Tutorials

Tutorials offer guided examples and demonstrations on operating the R&S NRPM. They are provided on the product page of the internet.

### 3.3 Instrument security procedures

Deals with security issues when working with the R&S NRPM in secure areas. It is available for download on the Internet.

### 3.4 Basic safety instructions

Contains safety instructions, operating conditions and further important information. The printed document is delivered with the instrument.

## 3.5 Data sheets and brochures

The data sheet contains the technical specifications of the R&S NRPM OTA power measurement solution. It also lists the options and their order numbers and optional accessories.

The brochure provides an overview of the instrument and deals with the specific characteristics, see [www.rohde-schwarz.com/brochure-datasheet/nrpm](http://www.rohde-schwarz.com/brochure-datasheet/nrpm).

## 3.6 Release notes and open source acknowledgment (OSA)

The release notes list new features, improvements and known issues of the current firmware version, and describe the firmware installation.

The open source acknowledgment document provides verbatim license texts of the used open source software, see [www.rohde-schwarz.com/firmware/nrpm](http://www.rohde-schwarz.com/firmware/nrpm).

### 3.6.1 Application notes, application cards, white papers, etc.

These documents deal with special applications or background information on particular topics.

[www.rohde-schwarz.com/application/nrpm](http://www.rohde-schwarz.com/application/nrpm)



## 4 Preparing for use

Here, you can find basic information about setting up the product for the first time.

- [Unpacking and checking](#)..... 17
- [Choosing the operating site](#)..... 17
- [Considerations for test setup](#)..... 18
- [Powering the R&S NRPM3\(N\) sensor module](#).....20
- [Hardware and software requirements](#)..... 20
- [Installing the software application and drivers](#)..... 23

### 4.1 Unpacking and checking

1. Unpack the product carefully.
2. Retain the original packing material. Use it when transporting or shipping the product later.
3. Using the delivery notes, check the equipment for completeness.
4. Check the equipment for damage.

If the delivery is incomplete or equipment is damaged, contact Rohde & Schwarz.

### 4.2 Choosing the operating site

Specific operating conditions ensure proper operation and avoid damage to the product and connected devices. For information on environmental conditions such as ambient temperature and humidity, see the data sheet.

#### Electromagnetic compatibility classes

The electromagnetic compatibility (EMC) class indicates where you can operate the product. The EMC class of the product is given in the data sheet.

- Class B equipment is suitable for use in:
  - Residential environments

## Considerations for test setup

- Environments that are directly connected to a low-voltage supply network that supplies residential buildings
- Class A equipment is intended for use in industrial environments. It can cause radio disturbances in residential environments due to possible conducted and radiated disturbances. It is therefore not suitable for class B environments. If class A equipment causes radio disturbances, take appropriate measures to eliminate them.

### 4.3 Considerations for test setup

Give particular attention to the following aspects when handling the components of the R&S NRPM OTA power measurement solution.

 For information on the options for connecting the sensor modules and test setups for the measurements, see [Chapter 6, "Setting up a measurement"](#), on page 38.

#### To prevent antenna damage

Damage is most likely to occur when you connect or disconnect an antenna modules.

1. **NOTICE!** Electrostatic discharge can quickly and imperceptibly damage or destroy the electrostatic sensitive antenna modules.

Ground yourself to prevent electrostatic discharge damage:

- a) Use a wrist strap and cord to connect yourself to ground.
- b) Use a conductive floor mat and heel strap combination.

2. **NOTICE!** If you touch the PCB (printed circuit board) of the antenna module, it can bend and thus lead to measurement inaccuracies.

Always hold the antenna modules by the housing. Take care not to touch the exposed top or bottom of the antenna module PCB.



### EMI impact on measurement results

Electromagnetic interference (EMI) can affect the measurement results.

To suppress electromagnetic radiation during operation:

- Use high-quality shielded cables, for example, double-shielded RF and interface cables.
- Always terminate open cable ends.
- Ensure that connected external devices comply with EMC regulations.
- When using the filtered cable feedthrough module R&S NRPM-ZD3, make sure that the housing of the **RF shielded box** is grounded, since the feedthrough module is grounded by the housing.

**i** Since the antenna module receives signals in a wide band, also outside the specified frequency bands, always measure in a controlled EM environment. In particular, when working with the R&S NRPM-Z3 interface module.

### Signal input and output levels

Information on signal levels is provided in the data sheet. Keep the signal levels within the specified ranges to avoid damage to the product and connected devices.

## 4.4 Powering the R&S NRPM3(N) sensor module

The electrical power for a R&S NRPM3(N) sensor module is supplied over one of the following interfaces:

- Host interface  
See "[Host interface connector \(3\)](#)" on page 30.
- LAN PoE interface  
Only available for R&S NRPM3N sensor modules, see "[LAN PoE interface \(6\)](#)" on page 31.

 If you use the Ethernet interface of the R&S NRPM3N sensor module, you have to provide the electrical power by power over Ethernet (PoE). In this case, you *cannot* provide the electrical power over the host interface instead.

### Choose the PoE power sourcing equipment (PSE) with care

Only use PoE power sourcing equipment (PSE) as specified in the IEEE standards 802.3af or IEEE 802.3at. Otherwise, the following can happen:

- If too much power is supplied, the R&S NRPM3N sensor module can get overheated and become damaged as a result.
- If the supplied power is not sufficient, the R&S NRPM3N sensor module does not work properly or not at all.

## 4.5 Hardware and software requirements

### 4.5.1 Hardware

The basic measurement equipment for an OTA power measurement with the R&S NRPM consists of:

- Three channel sensor module R&S NRPM3N or R&S NRPM3.
- Antenna modules:
  - R&S NRPM-A90: one at a minimum, and three at a maximum per sensor module.

## Hardware and software requirements

- R&S NRPM-A90D: occupies two channels of the sensor module. You can split the antenna module cables of one R&S NRPM-A90D antenna module on two interface or feedthrough modules.
- One of the following:
  - Filtered cable feedthrough module R&S NRPM-ZD3 (RF shielded box) and the interface cable R&S NRPM-ZKD3.
  - Three channel interface module R&S NRPM-Z3 (RF test chamber).  
Tool for fixing the strain relieve: torx screwdriver TX8.
- Desktop PC or laptop with:
  - Linux, macOS, or MS Windows operating system.
  - The required software, see [Mandatory software](#).
  - USB interface.
- LAN connection cables  
RJ-45 Ethernet cable (at least CAT6 STP).  
How to: [Chapter 6.3.4, "Using the LAN connection"](#), on page 50
- USB connection cables  
Double shielded cables, e.g. R&S NRP-ZKU, or NRP-ZK6.  
For this connection, Rohde & Schwarz provides two types of cables:
  - R&S NRP-ZKU cable with a USB connector
  - NRP-ZK6 cable with a push-pull type connectorYou can get both cables with different lengths up to 5 meters.  
How to: [Chapter 6.3.3, "Using the USB connection"](#), on page 47.

See [Chapter 6, "Setting up a measurement"](#), on page 38 for examples on how to set up an R&S NRPM OTA power measurement.

## 4.5.2 Mandatory software

The sensor module are smart sensor module that can be directly connected to a controlling PC.

To communicate with the sensor module, you can use the VISA I/O standard.

It is required to install:

- A driver software which supports I/O communication functions, known as VISA software library, see [Chapter 4.6.1, "VISA driver installation"](#), on page 24. You can use any VISA library, but we recommend that you use the R&S VISA.

## Hardware and software requirements

R&S VISA allows fast communication with the sensor module. It includes a trace tool for communication analysis, a testing tool for connection check, and a configuration tool for the definition of resources.

- R&S NRP Toolkit provides valuable utility programs, e.g. the firmware update program PureFW, see [Chapter 4.6.2, "R&S NRP Toolkit installation"](#), on page 24.

The following table points to helpful links where you can find the corresponding drivers.

**Table 4-1: Links to VISA driver software**

OS	VISA driver
MS Windows	<a href="http://www.rohde-schwarz.com/rsvisa">www.rohde-schwarz.com/rsvisa</a>
Linux	<a href="http://www.rohde-schwarz.com/rsvisa">www.rohde-schwarz.com/rsvisa</a> Also ask our customer support if you do not find a suitable VISA library for your Linux version at <a href="http://www.rohde-schwarz.com/support">www.rohde-schwarz.com/support</a>
macOS	<a href="http://www.rohde-schwarz.com/rsvisa">www.rohde-schwarz.com/rsvisa</a> <a href="http://www.ni.com/visa">www.ni.com/visa</a>

### 4.5.3 Optional software

Optionally, you can use the following software applications:

- R&S Power Viewer, an interactive power measurement software application from Rohde & Schwarz for measurements and evaluation of results with the sensor module.  
As a prerequisite R&S Power Viewer requires a VISA driver, and the installation of the R&S NRP Toolkit, see [Chapter 4.6.2, "R&S NRP Toolkit installation"](#), on page 24.
- Programming examples for customer-specific applications.  
Rohde & Schwarz provides various programming examples containing:
  - The GUI application R&S Power Viewer.
  - Programming examples in C/C++ or Python source code, for VISA communication protocols.
  - Project and auxiliary files.

The programming examples are included in the SDK (software development kit) of the R&S NRP Toolkit. You can select the SDK during installation, see ["To install the R&S NRP Toolkit on MS Windows"](#) on page 24. The folder labels are self-explanatory.

## Installing the software application and drivers

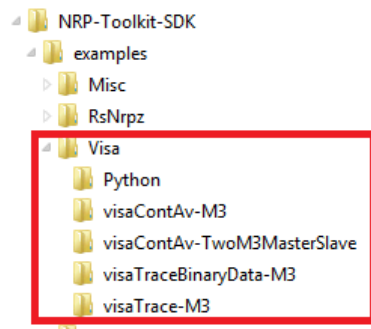

See [Table 4-2](#), which shows where you can get the packages for the corresponding OS.

**Table 4-2: Information to GUI application R&S Power Viewer and programming examples**

OS	R&S Power Viewer	Programming examples
MS Windows	Available on the Internet, see <a href="#">"To install the R&amp;S Power Viewer on an MS Windows:"</a> on page 27.	User documentation CD-ROM (included in delivery). Available, part of the R&S NRP Toolkit, see <a href="#">Chapter 4.6.2, "R&amp;S NRP Toolkit installation"</a> , on page 24.
Linux	Available on request for various Linux distributions, e.g. CentOS, Debian, RedHat, Ubuntu. See <a href="#">"To install the R&amp;S Power Viewer on Linux"</a> on page 28.	Packages available via the customer support: <a href="http://www.customersupport.rohde-schwarz.com">http://www.customersupport.rohde-schwarz.com</a>
macOS	Available, part of the R&S NRP Toolkit, macOS package, see <a href="#">"To install the R&amp;S NRP Toolkit on macOS"</a> on page 27.	

## 4.6 Installing the software application and drivers

This section describes the steps to install the required software applications, tools and drivers. The procedures refer to the programs recommended by Rohde & Schwarz.

### 4.6.1 VISA driver installation

#### To install the R&S VISA standardized software library on MS Windows:

- ▶ Consult the Rohde & Schwarz [www.rohde-schwarz.com/rsvisa](http://www.rohde-schwarz.com/rsvisa) web site, that provides the software and the necessary information.

If you are using VISA from another supplier, refer to the corresponding documentation on how to install the driver on your system. Usually, you start the received or downloaded installer \*.exe or \*.msi file.

#### To install a VISA driver on Linux or macOS:

- ▶ Refer to the documentation of the VISA driver supplier for instructions on how to install the VISA driver.

### 4.6.2 R&S NRP Toolkit installation

The R&S NRP Toolkit is a software-package that provides various utility programs for the whole Rohde & Schwarz NRP power sensor family, including the R&S NRPM sensor module.

#### To install the R&S NRP Toolkit on MS Windows

Rohde & Schwarz provides an R&S NRP Toolkit executable file, which installs the necessary low-level and high-level drivers and various tools on an MS Windows OS. Supported are MS Windows 8, MS Windows 8.1, and MS Windows 10 in both, the 32-bit and 64-bit architectures.

1. Download the latest installer file from the [www.rohde-schwarz.com/software/nrp\\_s\\_sn](http://www.rohde-schwarz.com/software/nrp_s_sn) website. The filename is similar to NRP-Toolkit-A.B.C.D.exe, where A, B, C and D are placeholders for the version number, e.g. NRP-Toolkit-4.10.6262.28523.exe.
2. Double-click the icon to start the installer.

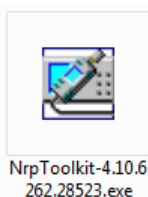



## Installing the software application and drivers

A dialog similar to the following appears.

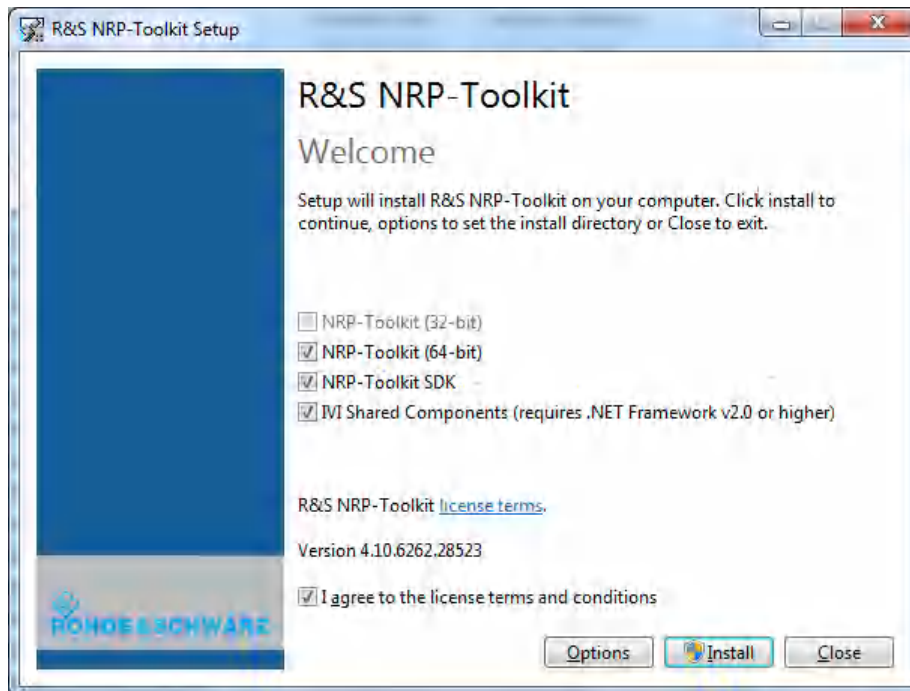

3. In the main dialog:
  - a) Select the R&S NRP Toolkit 64-bit option if your MS Windows PC has 64-bit architecture. The 32-bit version is always installed.
  - b) To include the programming examples, select "NRP-Toolkit SDK". To develop own application programs with the sensor module, we recommend that you activate this option to get various programming samples installed onto your PC.
  - c) Read the legal terms under "license terms"
  - d) Confirm that you agree to the license terms and conditions.
4. Continue with "Install" to complete the installation process.

When completed, you can find the included programming examples under `C:/ProgramData/Rohde-Schwarz/NRP-Toolkit-SDK/examples` if the "NRP-Toolkit SDK" option was activated before.

## To install the R&S NRP Toolkit on Linux

R&S NRP Toolkit versions for Linux distributions are available on request. Rohde & Schwarz provides installation packages for many popular distributions like Debian, CentOS, Ubuntu, OpenSuse, Raspbian, and others, in various versions. The packages constitute installable `*.deb` or `*.rpm` files which can be processed by the standard package tools (like `dpkg` or `rpm`) of the corresponding Linux distribution.

1. To obtain an R&S NRP Toolkit for your distribution, contact the Rohde & Schwarz customer support: [www.rohde-schwarz.com/support](http://www.rohde-schwarz.com/support).
2. The corresponding packages come with a `README.txt` file which describes in detail the steps to install the Linux R&S NRP Toolkit.

An R&S NRP Toolkit for Linux normally consists of several files (`*.deb` or `*.rpm` files). The associated files for a certain distribution all together make up the individual R&S NRP-Toolkit for Linux. The following examples show two random representatives. The filenames vary depending on the distributions and the versions.

### Example: Files used on Debian based systems

```
sudo dpkg -i nrpzmodule-dkms_4.2.2_all.deb           # Kernel driver
sudo dpkg -i libnrp_4.11-1_amd64.deb               # Transport layer
sudo dpkg -i librsnrpz_3.0.0.0-1_amd64.deb         # API
sudo dpkg -i libnrp-dev_4.11-1_amd64.deb           # Dev. files
                                                    (Transport layer)
sudo dpkg -i librsnrpz-dev_3.0.0.0-1_amd64.deb     # Dev.files
                                                    (API headers etc.)
```

### Example: Files used on RPM based systems

```
sudo rpm -i kmod-nrpzmodule-4.2.2-1.el7.centos.x86_64.rpm
                                                    # Kernel driver
sudo rpm -i libnrp-4.11-1.el7.centos.x86_64.rpm    # Transport layer
sudo rpm -i librsnrpz-3.0.0-1.el7.centos.x86_64.rpm
                                                    # API
sudo rpm -i libnrp-devel-4.11-1.el7.centos.x86_64.rpm
                                                    # Dev. files
                                                    (Transport layer)
sudo rpm -i librsnrpz-devel-3.0.0-1.el7.centos.x86_64.rpm
                                                    # Dev.files (API hdrs)
```

## Installing the software application and drivers

**To install the R&S NRP Toolkit on macOS**

Rohde & Schwarz provides a macOS NRP-Toolkit installer. The macOS version differs from the Linux and Windows NRP-Toolkit in the way that it includes a version of the R&S Power Viewer application. On the other operating systems, the R&S Power Viewer is a separately installable package. This application provides OTA functions for easy measurements with the R&S NRPM sensor module.

1. To obtain a macOS NRP-Toolkit installer, contact the Rohde & Schwarz customer support: [www.rohde-schwarz.com/support](http://www.rohde-schwarz.com/support).
2. Double-click the icon to start the installer.

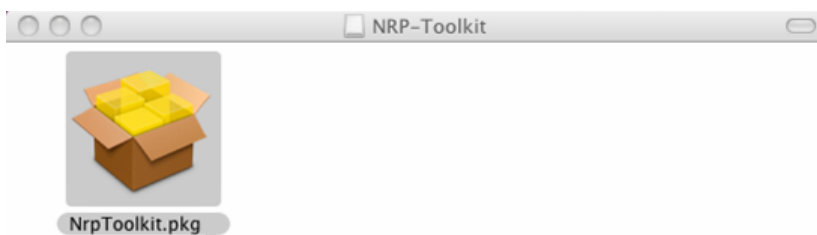

3. Follow the instructions of the installer to complete the installation.

**4.6.3 R&S Power Viewer installation**

The R&S Power Viewer is a software application that simplifies many power measurement tasks. It is part of the macOS NRP-Toolkit installer, and is available as a *separately* installable package for Linux and MS Windows.

The following instructions describe how to install the R&S Power Viewer. For detailed information, see the user manual of the R&S Power Viewer, which is part of the installation.

**To install the R&S Power Viewer on an MS Windows:**

1. Download the software package, e.g. from [www.rohde-schwarz.com/software/nrp\\_s\\_sn](http://www.rohde-schwarz.com/software/nrp_s_sn).
2. Start the installer program `PowerViewer_XXXXX_windows.msi` (XXXXX signifies a version number).
3. Follow the instructions of the installation wizard.

### To install the R&S Power Viewer on Linux

The R&S Power Viewer for Linux comes as a self-extracting installation package (\*.run file). Follow these steps to install the application in your Linux system:

1. Make sure that you have successfully installed a R&S NRP Toolkit for Linux suitable for your distribution.
2. Download the installer, e.g. from [www.rohde-schwarz.com/software/nrp\\_s\\_sn](http://www.rohde-schwarz.com/software/nrp_s_sn), or contact the customer support to obtain the file.
3. Open a terminal window.
4. Enter `sudo ./powerviewer_9.0_linux_x86.run`  
Note: The actual number (here 9.0) can be different.

### To install the R&S Power Viewer on macOS

The R&S Power Viewer is part of the R&S NRP Toolkit.

- For installation, see "[To install the R&S NRP Toolkit on macOS](#)" on page 27

## 5 R&S NRPM tour

The following chapters introduce the main hardware components of the R&S NRPM OTA power measurement solution.

### 5.1 R&S NRPM3(N) sensor modules

The R&S NRPM3(N) three-channel sensor module processes the measured values from up to three antenna modules in three separate channels.

This chapter provides an overview of the available connectors and LEDs of the R&S NRPM3(N) sensor modules. [Figure 5-1](#) shows the LAN sensor module on the left, and the USB sensor module on the right.

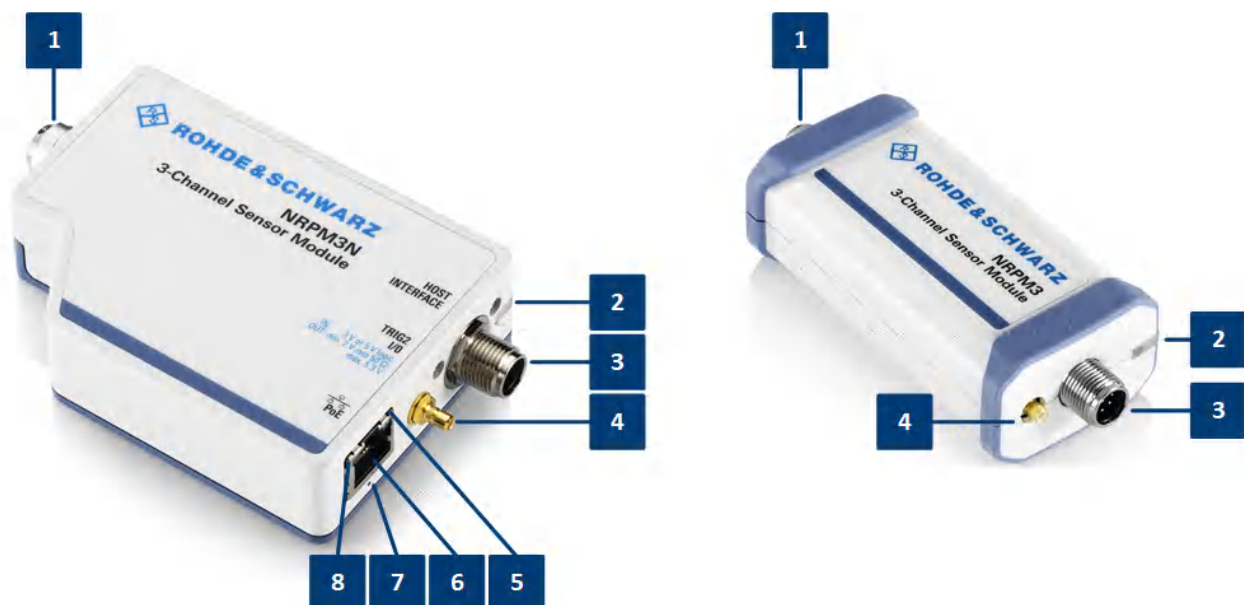

**Figure 5-1: R&S NRPM3N and R&S NRPM3**

- 1 = Antenna connector, see ["Antenna connector \(1\)"](#) on page 30
- 2 = Status LED, see ["Status LED \(2\)"](#) on page 30
- 3 = Host interface connector, see ["Host interface connector \(3\)"](#) on page 30
- 4 = Trigger I/O connector, see ["Trigger I/O connector \(4\)"](#) on page 31
- 5 = Network status LED, see ["Network status LED \(5\)"](#) on page 31
- 6 = LAN connector, see ["LAN PoE interface \(6\)"](#) on page 31
- 7 = LAN reset button, see ["LAN reset \(7\)"](#) on page 31
- 8 = Power over Ethernet status LED, see ["Power over Ethernet status LED \(8\)"](#) on page 31









### Antenna connector (1)

Multipole antenna connector for connecting the

- R&S NRPM3(N) to the interface module R&S NRPM-Z3.
- R&S NRPM3(N) to the filtered cable feedthrough module R&S NRPM-ZD3 with the interface cable R&S NRPM-ZKD3.

**Note:** Measurements with R&S NRPM3N LAN sensor modules require that you use the latest version of the R&S NRPM-ZKD3 interface cable (1436.2984.02).

### Status LED (2)

Indication		State
	White	Idle state. The sensor module performs no measurement and is ready for use.
	Flashing white	Firmware update is in progress
	Slow flashing white	Sanitizing is in progress
	Yellow	Wait for trigger state
	Green	Measuring state
	Turquoise blue	Zeroing is in progress
	Slow flashing red	A static error. You can query the type of the error with <a href="#">SYSTem:SERRor?</a> on page 133
	Fast flashing red	A critical static error. You can query the type of the error with <a href="#">SYSTem:SERRor?</a> on page 133 <b>Note:</b> If a critical error occurs after a firmware update, the update was not successful. Perform the firmware update again. See <a href="#">Chapter 12.3, "Problems during a firmware update"</a> , on page 204

### Host interface connector (3)

The host interface connector is used for establishing a connection between the sensor module and the USB host. For the connection, you need an external cable.

See:

- [Chapter 4.5.1, "Hardware"](#), on page 20
- [Chapter 6.3.3, "Using the USB connection"](#), on page 47

The host interface connector also contains the trigger1 connection for input or output of a trigger signal, e.g., to synchronize several sensor modules in trigger sender or in receiver mode.

## R&amp;S NRPM3(N) sensor modules

For information on how to assign the signals to the ports, see [Chapter 10.10, "Configuring the trigger"](#), on page 172.

**Trigger I/O connector (4)**

The trigger I/O is a connector of SMB type.



You can use this interface as an input for an external trigger signal.

Optionally, you can use it as an output, e.g. to synchronize several sensor modules with the sensor working in the trigger sender mode, see ["Host interface connector \(3\)"](#) on page 30.

For information on how to assign the signals to the ports, see [Chapter 10.10, "Configuring the trigger"](#), on page 172.

**Network status LED (5)**

Indicates whether the LAN connection to the network is established.

Indication		State
	Green	The R&S NRPM3N sensor module is connected to the network. The IP address assigned by the DHCP or manually is valid.
	Red	The R&S NRPM3N is not connected to the network properly. Either the connection is erroneous or the assigned IP address of the sensor module is not valid.

**LAN PoE interface (6)**

R&S NRPM3N LAN sensor modules only

RJ-45 connector to connect the Ethernet interface of a R&S NRPM3N sensor module to a local area network (LAN).

**Note:** Ethernet interface requires PoE (power over Ethernet). This Ethernet interface provides the electrical power by power over Ethernet (PoE) for the sensor modules. PoE is mandatory, when using the LAN interface, since the USB port does not provide sufficient power. See [Chapter 4.4, "Powering the R&S NRPM3\(N\) sensor module"](#), on page 20.

**LAN reset (7)**

Button for resetting the Ethernet connection parameters of the R&S NRPM3N sensor module to its default values.

**Power over Ethernet status LED (8)**

Indicates whether the R&S NRPM3N sensor modules is powered over PoE.

## R&amp;S NRPM-A90 and R&amp;S NRPM-A90D antenna modules

Indication		State
●	Green	The interface provides PoE. The sensor module is powered.
○	Not illuminated	PoE power is not applied.

## 5.2 R&S NRPM-A90 and R&S NRPM-A90D antenna modules

This section introduces the antenna modules of the R&S NRPM OTA power measurement solution.

For more information, see the data sheet.

### R&S NRPM-A90

Single polarized antenna module with integrated diode detector



1 = PCB (printed circuit board)

2 = Interface cable

3 = Signaling LED



## R&amp;S NRPM-A90 and R&amp;S NRPM-A90D antenna modules

**R&S NRPM-A90D**

Dual polarized antenna module with integrated diode detectors

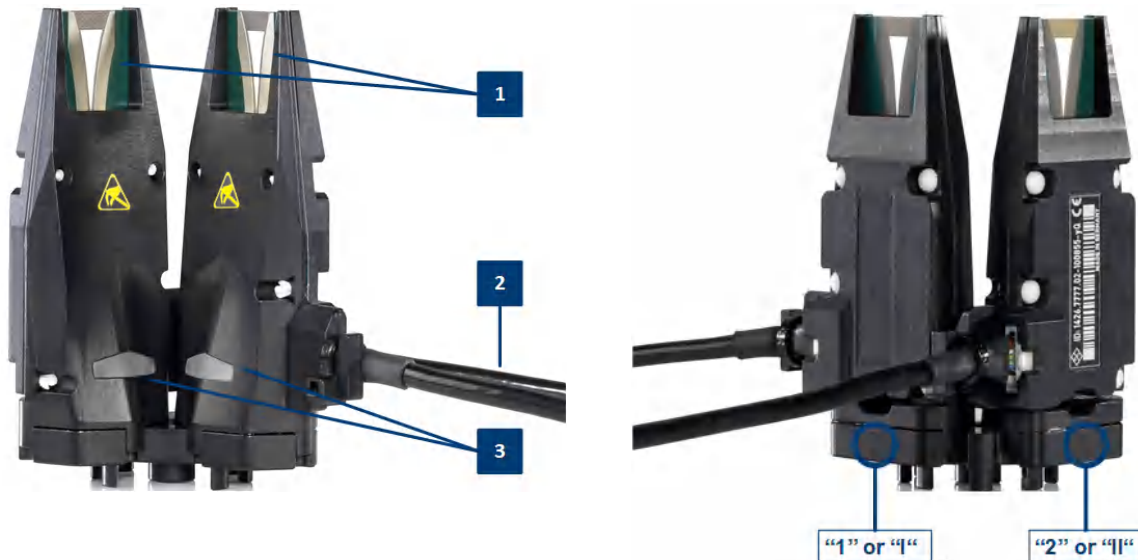

- 1 = PCBs (printed circuit boards)
- 2 = Interface cables
- 3 = Signaling LEDs

To distinguish the feeds, the carrier of the R&S NRPM-A90D antenna module is labeled on the back with the corresponding letters "1" and "2", or "I" and "II".

An R&S NRPM-A90D module occupies two channels on the R&S NRPM3.

The R&S NRPM-A90/-A90D antenna modules are designed to work with the R&S NRPM3(N) sensor modules.



Electrostatically sensitive components. Follow the instructions described in ["To prevent antenna damage"](#) on page 18.



R&S NRPM OTA power measurements with the antenna modules R&S NRPM-A90 and R&S NRPM-A90D require at least FW version NRPM3\_18.05.08.03.rsu or NRPM3N\_18.05.08.03.rsu on the sensor module. Earlier FW versions support only the predecessor antenna modules R&S NRPM-A66.

**Antenna module cable (2)**

Cable firmly connected to the antenna modules for connection to the R&S NRPM-ZD3 feedthrough or the R&S NRPM-Z3 interface modules.

**Note:** The contact durability of these connectors is limited, therefore note the plug-in cycles specified in the data sheet.

### Signaling LED (3)

LED for signaling purposes.

You can use the LED for mapping between the antenna module location and the sensor module channel, or for own signaling purposes.

To turn on the LED, use the SCPI command `SYSTem:LED:CHANnel<Channel>:COLor` on page 130. The LED color is blue.

## 5.3 R&S NRPM-ZD3 feedthrough module

The R&S NRPM-ZD3 filtered cable feedthrough module combines up to three antenna modules to one connector. From the cable feedthrough module, three independent antenna measurements are led to the R&S NRPM3(N) sensor module over the R&S NRPM-ZKD3 interface cable.

 Measurements with R&S NRPM3N LAN sensor modules require that you use the latest version of the R&S NRPM-ZKD3 interface cable (1436.2984.02).

The filtered cable feedthrough is developed for use with a shielded RF shielded box, e.g. the R&S CMQ200.

## R&amp;S NRPM-ZD3 feedthrough module

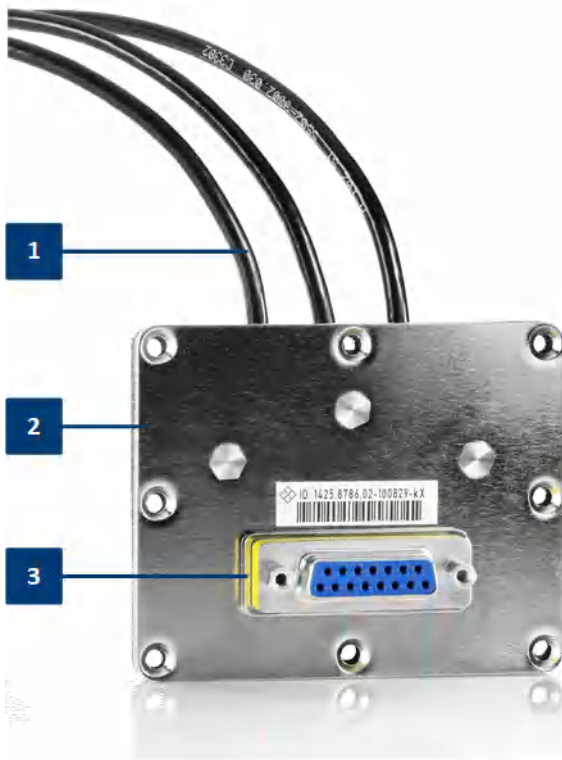

**Figure 5-2: The R&S NRPM-ZD3 feedthrough module**

- 1 = Antenna module cable connectors
- 2 = Cable feedthrough module
- 3 = Sensor module cable connector

### **Antenna module cable connectors (1)**

Micro miniature connectors (10 pin) for connecting up to three antenna module cables.

### **Filtered cable feedthrough module (2)**

R&S NRPM-ZD3 filtered cable feedthrough for combining three antenna module cables to one sensor module cable R&S NRPM-ZKD3.

### **Sensor module cable connector (3)**

SUB-D connector (15 pin) for connecting to the sensor modules with the interface cable R&S NRPM-ZKD3.

## 5.4 R&S NRPM-Z3 interface module

For direct connection inside an EM controlled environment, you can use the R&S NRPM-Z3 interface module. Plugged directly to the R&S NRPM3(N) three channel sensor module, the R&S NRPM-Z3 interface module can host up to three antenna modules without additional cables required.

This section introduces the interface module for connecting, e.g. three antenna module cables for OTA power measurements in an EM-controlled environment, e. in an RF test chamber.

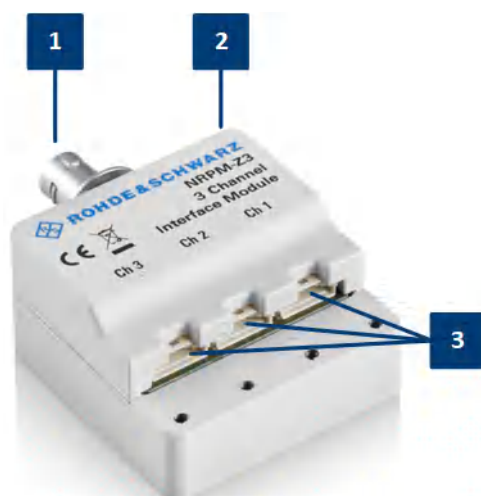

**Figure 5-3: The R&S NRPM-Z3 interface module**

- 1 = Connector to sensor module
- 2 = Interface module
- 3 = Antenna module cable connectors

### Connector to sensor module (1)

16-pin push-pull connector for connecting to the sensor module.

### Interface module (2)

R&S NRPM-Z3 three channel interface module to pass up to three antenna module cables to one R&S NRPM3(N) sensor module.

### Antenna module cable connectors (3)

Micro miniature connectors (10 pin) for connecting the antenna module cables.

R&amp;S NRPM-Z3 connected to the R&amp;S NRPM3

## 5.5 R&S NRPM-Z3 connected to the R&S NRPM3



*Figure 5-4: R&S NRPM-Z3 connected to R&S NRPM3*

- 1 = R&S NRP-ZKU
- 2 = R&S NRPM3
- 3 = R&S NRPM-Z3
- 4 = Strain relieve
- 5 = Antenna module cables

### **Strain relieve (4)**

Strain relieve for the antenna module cable connections.

### **Antenna module cables (5)**

Cables firmly connected to the antenna modules for connection to the R&S NRPM-Z3 interface module or the R&S NRPM-ZD3 feedthrough interface modules.

## 6 Setting up a measurement

This section points out important aspects to consider when setting up an R&S NRPM OTA power measurement. It shows some test setup examples and brief instructions on how to connect the components. You can also find references to the product page and the user manual of the RF shielded box R&S CMQ200 or an RF test chamber.

- [Test setup examples](#)..... 38
- [R&S CMQ200 shielding cube](#)..... 42
- [Connecting an R&S NRPM OTA power measurement](#)..... 43
- [Starting the measurement](#)..... 57

### 6.1 Test setup examples

The following section shows some test setups examples with an RF shielded box and within an RF test chamber. The main difference is that the sensor module is either inside, or outside the EM-controlled test environment:

- **RF shielded box**  
The sensor module is outside the RF shielded box, connected to the antenna modules via the feedthrough module (R&S NRPM-ZD3) and the interface cable (R&S NRPM-ZKD3).
- **RF test chamber**  
The sensor module is inside an RF test chamber, directly connected to the antenna modules via the interface module (R&S NRPM-Z3).

See also the application note [1GP118](#).

 Always operate the antenna modules in an environment that is protected against electromagnetic interference.

The described examples refer to measurements performed with R&S Power Viewer, which allows you to measure the readings of up to four R&S NRPM3(N) sensor modules (12 antenna module channels) at a time. This number corresponds to 12 single or 6 dual polarized antenna modules. Technically, more are possible, i.e. you can select any number of antenna modules for your measurement.

**i** Test setups with R&S NRPM3N LAN sensor modules and the R&S NRPM-ZKD3 interface cables for connection to a RF shielded box, require that you use the latest version of the interface cable (1436.2984.02).

### Single antenna module solution

The base configuration with one antenna module measures the power of the incident wave from the DUT to the antenna module, e.g. to calibrate the output power of your DUT.

#### Example:

Setup with one single polarized R&S NRPM-A90 antenna module installed in an RF shielded box (feedthrough module):

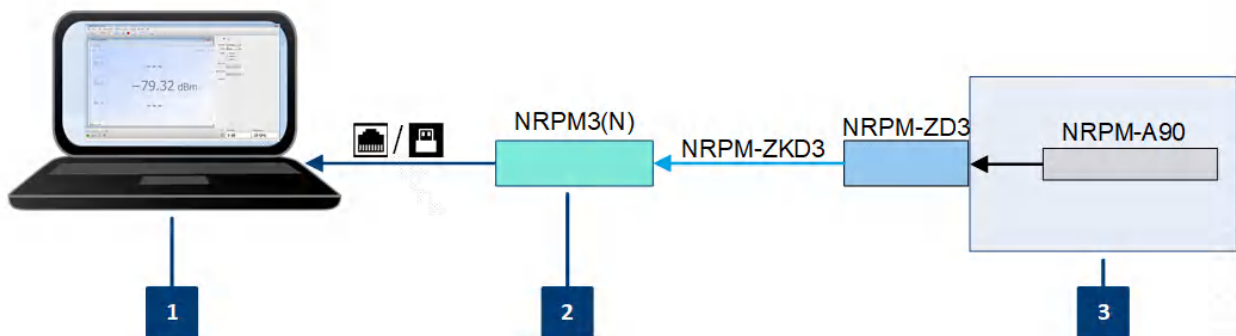

**Figure 6-1: One R&S NRPM-A90 in an RF shielded box**

- 1 = Controller PC
- 2 = Sensor module
- 3 = RF shielded box

### Multiple spatially distributed antenna modules

With several antenna modules distributed in an area, you can test the beamforming function of a DUT. The more antenna modules are installed, the higher is the measurement accuracy during beamforming tests. In addition, you can derive matrices for swiveling the beam of the antenna module around two axes.

**Example:**

Setup with multiple single polarized R&S NRPM-A90 antenna modules in an RF shielded box (feedthrough modules):

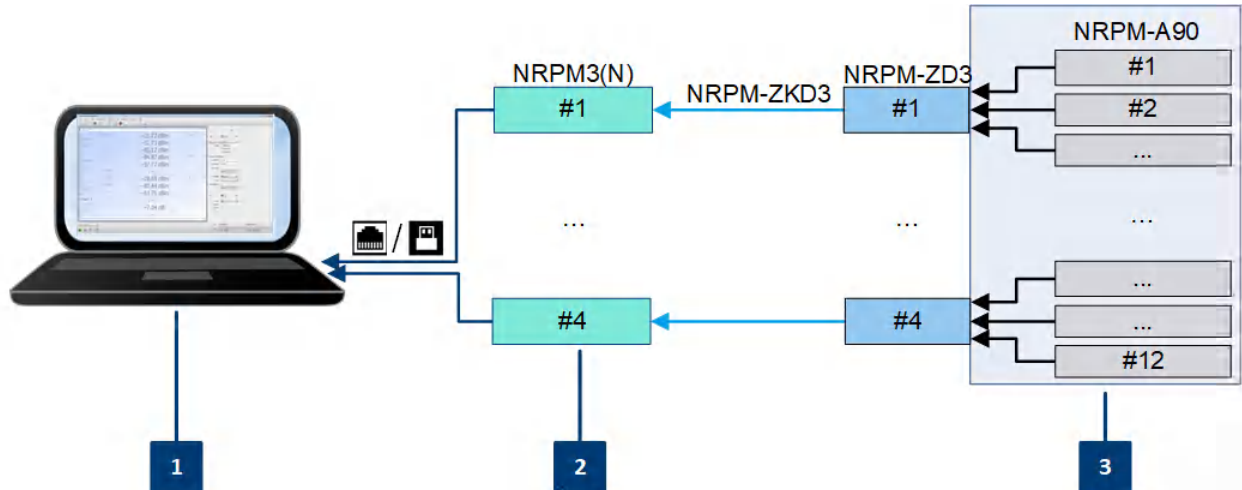

**Figure 6-2: Multiple R&S NRPM-A90 in an RF shielded box**

- 1 = Controller PC
- 2 = Sensor modules
- 3 = RF shielded box



**Example:**

Setup with multiple single polarized R&S NRPM-A90 antenna modules in an RF test chamber (interface modules):

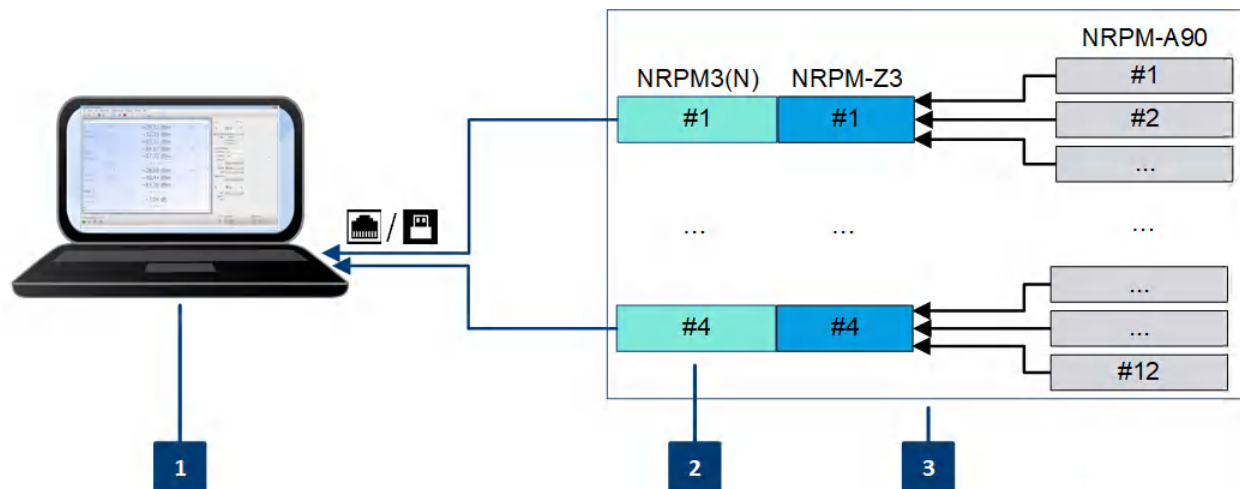
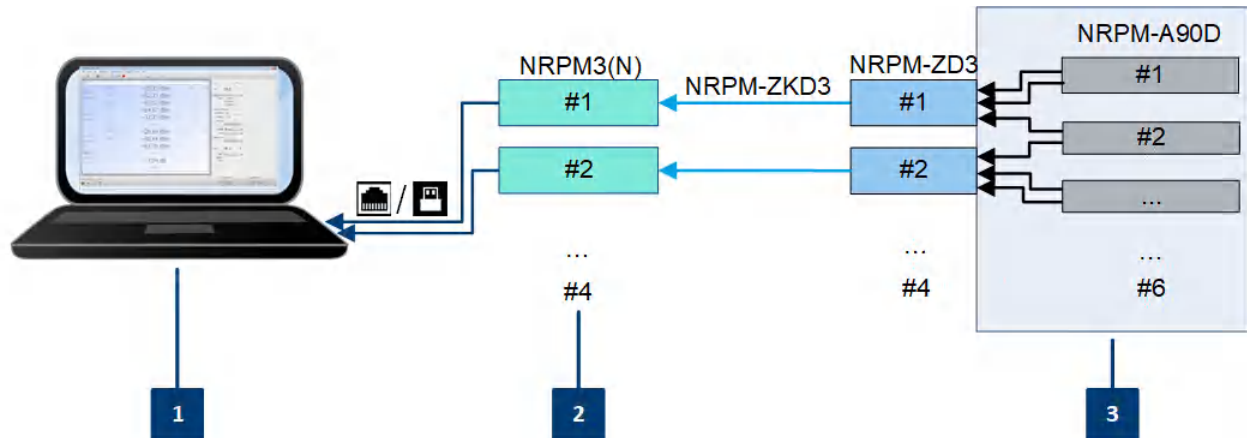

**Figure 6-3: Multiple R&S NRPM-A90 in an RF test chamber**

- 1 = Controller PC
- 2 = Sensor modules
- 3 = RF test chamber

**Example:**

Setup with dual polarized R&S NRPM-A90D antenna modules in an RF shielded box with feedthrough modules:



**Figure 6-4: Setup with multiple R&S NRPM-A90D in an RF shielded box**

- 1 = Controller PC
- 2 = Sensor modules
- 3 = RF shielded box

**Note:** Since one dual polarized antenna module allocates two channels of the sensor module, you can use a maximum of three antenna modules with two sensor modules. If your test setup requires more antenna modules, use additional sensor modules. In this test setup, you can measure the readings of up to six antenna modules with four sensor modules.

To set up a measurement with R&S NRPM-A90D dual polarized antenna modules in an RF test chamber, use the corresponding modules, as shown above.

## 6.2 R&S CMQ200 shielding cube

The R&S CMQ200 Shielding Cube, in this manual referred to as **RF shielded box**, enables reliable and reproducible measurements when a controlled EM test environment is needed.

## Connecting an R&amp;S NRPM OTA power measurement

As the R&S CMQ200 is a stand-alone product of Rohde & Schwarz, this section does not describe the box and measurement setups in detail. If you perform an OTA measurement with the box, you find the necessary information at:

- [www.rohde-schwarz.com/product/cmq200](http://www.rohde-schwarz.com/product/cmq200), providing an overview of the R&S CMQ200 RF shielded box with the available models and the variety of antenna holders and feedthrough options.
- [www.rohde-schwarz.com/manual/cmq200](http://www.rohde-schwarz.com/manual/cmq200), providing the user manual, which describes the hardware, the options and the accessories, and how to install and configure the antenna modules.
- [www.rohde-schwarz.com/brochure-datasheet/cmq200](http://www.rohde-schwarz.com/brochure-datasheet/cmq200), providing the product brochure, which deals with specific characteristics, and contains the technical specifications and ordering information.

### 6.3 Connecting an R&S NRPM OTA power measurement

To start up an R&S NRPM OTA power measurement, it is assumed that the following conditions are met:

- All required hardware is available and ready for use, see [Chapter 4.5, "Hardware and software requirements"](#), on page 20.
- The firmware version of the sensor module has release 2.00 or later, required for R&S NRPM OTA power measurements with the antenna modules R&S NRPM-A90 or R&S NRPM-A90D.  
How to: see [Chapter 8, "Firmware update"](#), on page 83.
- The software and drivers are installed on the controller PC.  
How to: see [Chapter 4.6, "Installing the software application and drivers"](#), on page 23.
- The (DUT) is installed and ready for operation.
- The R&S NRPM OTA power measurement components are powered off.

• <a href="#">Connecting the RF frontend</a> .....	44
• <a href="#">Connecting to the controller PC</a> .....	46
• <a href="#">Using the USB connection</a> .....	47
• <a href="#">Using the LAN connection</a> .....	50
• <a href="#">Connecting to the network</a> .....	54

### 6.3.1 Connecting the RF frontend

The following steps describe how to connect the antenna modules and a sensor module in both, an RF shielded box or an RF test chamber.

#### 6.3.1.1 Connecting the RF frontend in an RF shielded box

 When you are working with the dual-polarized antenna modules R&S NRPM-A90D, notice the feeds of the vertical and horizontal antenna modules. You can find out the alignment with the identification numbers "1" or "I" (vertical) and "2" or "II" (horizontal) on the carrier of the antenna modules.

#### Required equipment

- RF shielded box, e.g. the R&S CMQ200
- Suitable antenna ring, see the accessories available for the corresponding RF shielded box
- One or more antenna modules, e.g. R&S NRPM-A90D or R&S NRPM-A90
- [R&S NRPM-ZD3 \(2\)](#) mounted in the RF shielded box
- R&S NRPM-ZKD3 interface cable.
- [R&S NRPM3\(N\) \(1\)](#) sensor module

#### To connect the RF frontend in the RF shielded box

1. In the RF shielded box, install the antenna ring.
2. **NOTICE!** Risk of antenna damage. Observe "[To prevent antenna damage](#)" on page 18.

Mount the antenna modules.

For connecting options, see the user documentation of the RF shielded box you are using, e.g. as referred to in [Chapter 6.2, "R&S CMQ200 shielding cube"](#), on page 42.

3. **NOTICE!** Risk of cable breakage. The connectivity of the antenna cable ends is sensitive, and therefore the contact durability of the connection is limited. Do not connect and disconnect the cables to the feedthrough board frequently.

## Connecting an R&amp;S NRPM OTA power measurement

Connect each antenna module cable to the antenna module cable connectors of the feedthrough module [R&S NRPM-ZD3 \(2\)](#).

4. Outside the RF shielded box, make sure that the sensor module is powered off, i.e. not yet connected to the power sourcing interface, see [Chapter 4.4, "Powering the R&S NRPM3\(N\) sensor module"](#), on page 20.
5. To connect the [R&S NRPM3\(N\) \(1\)](#) sensor module to the feedthrough module [R&S NRPM-ZD3 \(3\)](#):
  - a) Connect the 15-pin Sub-D connector of the interface cable R&S NRPM-ZKD3 to the [R&S NRPM-ZD3 \(3\)](#) feedthrough module.
  - b) Observe the guide gap of the sensor connector to ensure correct alignment to the mating antenna connector of the sensor module.
  - c) Insert the sensor connector of the interface cable straight into the antenna connector of the sensor module.
6. Continue with [Connecting to the controller PC](#).

**To disconnect the R&S NRPM-ZKD3 from the sensor module**

1. Disconnect the power sourcing interface of the sensor module.
2. Pull the sensor connector of the cable from the antenna connector of the sensor module. Take care not to tilt it.

**6.3.1.2 Connecting the RF frontend in an RF test chamber**

 When you are working with the dual-polarized antenna modules R&S NRPM-A90D, notice the feeds of the vertical and horizontal antenna modules. You can find out the alignment with the identification numbers "1" or "I" (vertical) and "2" or "II" (horizontal) on the carrier of the antenna modules.

**Required equipment**

- Suitable antenna ring, see the accessories available for the R&S NRPM3(N) OTA power measurement solution
- One or more antenna modules, e.g. R&S NRPM-A90D or R&S NRPM-A90
- [NRPM-Z3 \(3\)](#)
- [R&S NRPM3\(N\) \(1\)](#) sensor module

## Connecting an R&amp;S NRPM OTA power measurement

**To connect RF frontend with the sensor module in an RF test chamber**

1. **NOTICE!** Risk of antenna damage. Observe ["To prevent antenna damage"](#) on page 18.  
In the RF test chamber, mount the antenna modules.  
For information on the connecting options, refer to the documentation of the antenna equipment.
2. On the interface module [NRPM-Z3 \(3\)](#), dismount the strain relieve [NRPM-Z3 \(4\)](#) using a torx screwdriver TX8.
3. **NOTICE!** Risk of broken cables. The connectivity of the antenna cable ends is sensitive, and therefore the contact durability of the connection is limited.  
Do not connect and disconnect the cables to the interface module frequently.  
Connect each antenna module cable to the antenna module cable connectors of the interface module.
4. Mount the strain relieve of the interface module.
5. To connect the R&S NRPM-Z3 interface module to the R&S NRPM3(N) sensor module, see [R&S NRPM-Z3 connected to R&S NRPM3](#):
  - a) Make sure that the sensor module is powered off, i.e. not yet connected to the power sourcing interface, see [Chapter 4.4, "Powering the R&S NRPM3\(N\) sensor module"](#), on page 20.
  - b) Insert the 16-pin sensor connector of the [R&S NRPM-Z3 interface module](#) straight into the antenna connector of the R&S NRPM3(N). Take care that the guide gap of the sensor connector fits to the guide lug of the mating antenna connector of the sensor module.
6. Continue with [Connecting to the controller PC](#).

**To disconnect the R&S NRPM-Z3 from the sensor module**

1. Disconnect the power sourcing interface of the sensor module.
2. Pull the sensor connector of the interface module from the antenna connector of the sensor module. Take care not to tilt it.

**6.3.2 Connecting to the controller PC**

The controlling host of the R&S NRPM OTA power measurement solution is a computer, using a supported software for controlling the R&S NRPM3(N) sensor modules, see [Chapter 4.5, "Hardware and software requirements"](#), on page 20.

## Connecting an R&amp;S NRPM OTA power measurement

You can connect the sensor module using the LAN interface, when working with the R&S NRPM3N. To connect the R&S NRPM3, use the USB host interface.

To connect the sensor module to the controller PC, see:

- [Chapter 6.3.3, "Using the USB connection"](#), on page 47
- [Chapter 6.3.4, "Using the LAN connection"](#), on page 50

### 6.3.3 Using the USB connection

You can connect all R&S NRPM3(N) sensor modules to the USB interface of a computer. The high-speed USB connection supports control of all R&S NRPM3(N) types. It also provides the power supply for the R&S NRPM3 sensor modules.

 USB power is not sufficient for R&S NRPM3N sensor modules. See [Chapter 4.4, "Powering the R&S NRPM3\(N\) sensor module"](#), on page 20.

#### 6.3.3.1 Simple USB connection

##### Required equipment

- R&S NRPM3(N)
- R&S NRP-ZKU
- Controller PC with USB host interface and installed VISA driver or R&S NRP Toolkit and R&S Power Viewer Mobile

##### Setup

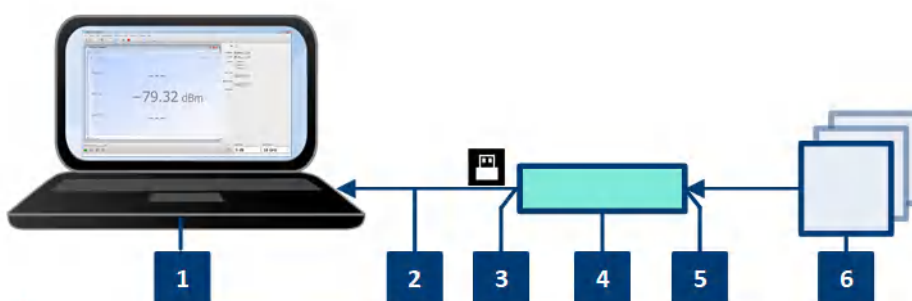

Figure 6-5: Setup with an R&S NRP-ZKU

## Connecting an R&amp;S NRPM OTA power measurement

- 1 = Controller PC
- 2 = R&S NRP-ZKU
- 3 = USB host interface connector
- 4 = R&S NRPM3 sensor module
- 5 = Antenna connector
- 6 = Antenna module(s)

**To connect the R&S NRPM3 sensor module and the controller PC**

Setup as shown in [Figure 6-5](#).

1. Use the cable provided for the setup to connect to the R&S NRPM3 host interface, see [Chapter 4.5.1, "Hardware"](#), on page 20.
  - a) Insert the screw-lock cable connector of the R&S NRP-ZKU into the host interface [R&S NRPM3 \(2\)](#) connector of the sensor module.
  - b) Tighten the union nut manually.
2. Connect the R&S NRP-ZKU USB connector to the controller PC.

**To disconnect the R&S NRP-ZKU cable from the sensor module**

1. Loosen the union nut of the screw-lock cable connector.
2. Remove the cable.

**6.3.3.2 Sensor hub R&S NRP-Z5**

The R&S NRP-Z5 sensor hub (high-speed USB 2.0) can host up to four sensor modules and provides simultaneous external triggering to all connected sensors.

**Required equipment**

- 1 to 4 R&S NRPM3 sensor module
- 1 NRP-ZK6 per sensor
- R&S NRP-Z5 sensor hub with external power supply unit and USB cable
- Controller PC with USB host interface and installed VISA driver, R&S NRP Toolkit and R&S Power Viewer Mobile



## Setup

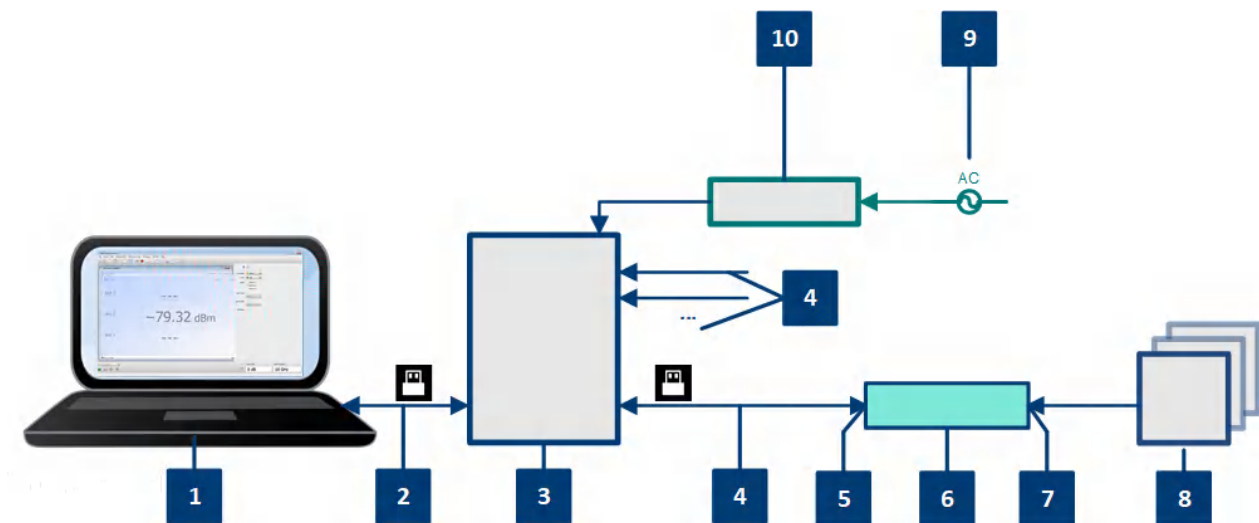

**Figure 6-6: Setup with an R&S NRP-Z5 sensor hub**

- 1 = Controller PC
- 2 = USB cable
- 3 = R&S NRP-Z5 sensor hub
- 4 = NRP-ZK6 cables
- 5 = USB host interface connector
- 6 = R&S NRPM3 sensor module
- 7 = Antenna connector
- 8 = Antenna module(s)
- 9 = AC power supply
- 10 = External power supply unit

### To connect a setup with several sensor modules using the R&S NRP-Z5

Setup as shown in [Figure 6-6](#).

1. Connect the R&S NRP-Z5 to the computer.
2. Connect the NRP-ZK6 to the power sensor, see ["To connect the R&S NRPM3 sensor module and the controller PC"](#) on page 48.
3. Connect the USB connector of the NRP-ZK6 to the R&S NRP-Z5 sensor hub.
4. If necessary, connect further sensor modules to the sensor hub accordingly.
5. Connect the external power supply unit to the R&S NRP-Z5 and to the mains.
6. Establish the connection of the antenna modules as described in [Chapter 6.3.1, "Connecting the RF frontend"](#), on page 44.

## Connecting an R&amp;S NRPM OTA power measurement

- On the computer, start a software application to execute the measurement, see [Chapter 7, "Performing measurements"](#), on page 58.

### 6.3.4 Using the LAN connection

**i** Requires the R&S NRPM3N LAN sensor module with networking capabilities.

Depending on the available equipment, you have several options to connect a R&S NRPM3N LAN sensor module to the controller PC.

#### Setup with a PoE Ethernet switch

To connect the R&S NRPM3N to a LAN, use a PoE switch, e.g. the R&S NRP-ZAP1. This switch provides the power supply and control for the antenna modules.

#### Required equipment

- 1 R&S NRPM3N sensor module
- 2 RJ-45 Ethernet cables,  
To avoid any impact, use at least category 6 STP cables for the LAN connection, see [Chapter 4.5.1, "Hardware"](#), on page 20.
- 1 Ethernet switch, supporting PoE power delivery, e.g., R&S NRP-ZAP1
- Controller PC with LAN interface and installed VISA driver or R&S NRP Toolkit and R&S Power Viewer Mobile

#### Setup

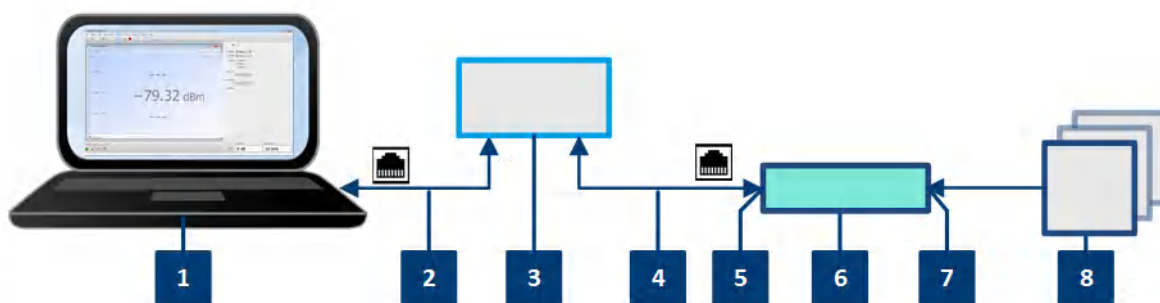

Figure 6-7: Setup with a PoE Ethernet switch

## Connecting an R&amp;S NRPM OTA power measurement

- 1 = Controller PC
- 2, 4 = RJ-45 Ethernet cables
- 3 = Ethernet switch
- 5 = LAN connector (RJ-45 Ethernet PoE interface)
- 6 = R&S NRPM3N LAN sensor module
- 7 = Antenna connector
- 8 = Antenna module(s)

**To connect the R&S NRPM3N to the controller PC with the PoE Ethernet switch**

1. **NOTICE!** Risk of sensor damage. Only use PoE power sourcing equipment (PSE) as described in [Chapter 4.4, "Powering the R&S NRPM3\(N\) sensor module"](#), on page 20.  
Connect the [LAN PoE interface \(5\)](#) of the sensor module to the Ethernet switch.
2. Connect the controller PC to the Ethernet switch.
3. On the controller, establish a connection between the sensor module and the network, see [Chapter 6.3.5, "Connecting to the network"](#), on page 54.

**Setup with a PoE injector and a non-PoE Ethernet switch****Required equipment**

- 1 R&S NRPM3N sensor module
- 3 RJ-45 Ethernet cables  
To avoid any impact, use at least category 6 STP cables for the LAN connection, see [Chapter 4.5.1, "Hardware"](#), on page 20.
- 1 PoE injector
- 1 non-PoE Ethernet switch
- Controller PC with LAN interface and installed VISA driver or R&S NRP Toolkit and R&S Power Viewer Mobile
- Controller PC

## Connecting an R&amp;S NRPM OTA power measurement

## Setup

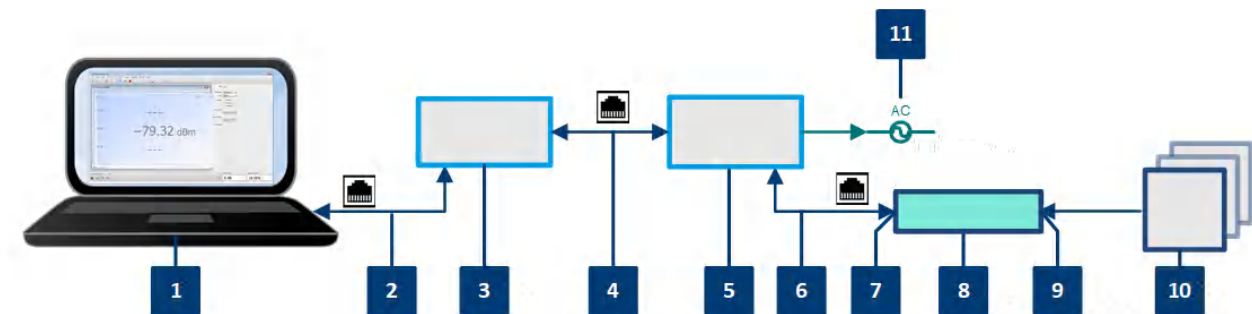

**Figure 6-8: Setup with a PoE injector and a non-PoE Ethernet switch**

- 1 = Controller PC
- 2,4,6 = RJ-45 Ethernet cables
- 3 = Non-PoE Ethernet switch
- 5 = PoE injector
- 7 = LAN connector (RJ-45 Ethernet PoE interface)
- 8 = R&S NRPM3N LAN sensor module
- 9 = Antenna connector
- 10 = Antenna module(s)
- 11 = AC power supply

### To connect the R&S NRPM3N to the controller PC with the PoE injector and a non-PoE Ethernet switch

1. **NOTICE!** Risk of sensor damage. Only use PoE power sourcing equipment (PSE) as described in [Chapter 4.4, "Powering the R&S NRPM3\(N\) sensor module"](#), on page 20.  
Connect the [LAN PoE interface \(5\)](#) of the sensor module to the PoE injector.
2. Connect the PoE injector to the AC supply (mains).
3. Connect the input of the PoE injector to the non-PoE Ethernet switch.
4. Connect the controller PC to the non-PoE Ethernet switch.
5. On the controller, establish a connection between the sensor module and the network, see [Chapter 6.3.5, "Connecting to the network"](#), on page 54.

### Setup with a PoE injector

#### Required equipment

- 1 R&S NRPM3N sensor module
- 2 RJ-45 Ethernet cables

## Connecting an R&amp;S NRPM OTA power measurement

To avoid any impact, use at least category 6 STP cables for the LAN connection, see [Chapter 4.5.1, "Hardware"](#), on page 20.

- 1 PoE injector
- Controller PC with LAN interface and installed VISA driver or R&S NRP Toolkit and R&S Power Viewer Mobile

## Setup

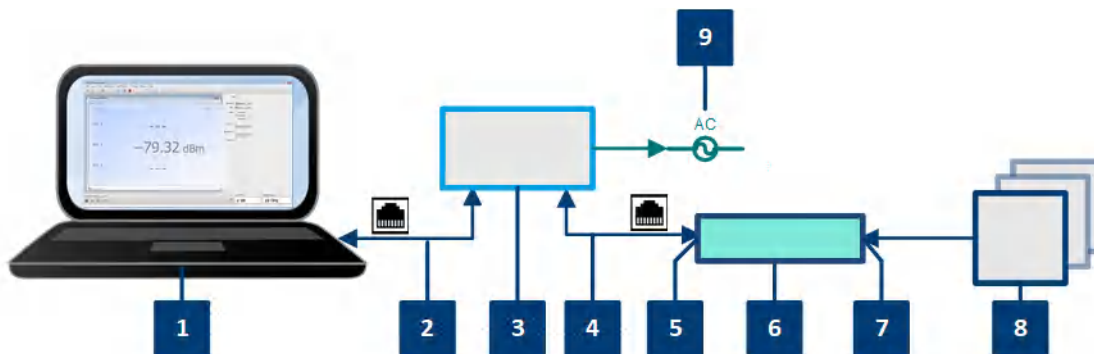

**Figure 6-9: Setup with a PoE injector**

- 1 = Controller PC
- 2, 4 = RJ-45 Ethernet cable
- 3 = PoE injector
- 5 = LAN connector (RJ-45 Ethernet PoE interface)
- 6 = R&S NRPM3N R&S NRPM3N LAN sensor module
- 7 = Antenna connector
- 8 = Antenna module(s)
- 9 = AC power supply

### To connect the R&S NRPM3N to the controller PC with the PoE injector

1. **NOTICE!** Risk of sensor damage. Only use PoE power sourcing equipment (PSE) as described in [Chapter 4.4, "Powering the R&S NRPM3\(N\) sensor module"](#), on page 20.  
Connect the [LAN PoE interface \(5\)](#) of the sensor module to the PoE injector.
2. Connect the PoE injector to the AC supply (mains).
3. Connect the controlling host to the input of the PoE injector.
4. On the controller, establish a connection between the sensor module and the network.

### 6.3.5 Connecting to the network

There are two methods to establish a network connection:

- The R&S NRPM3N LAN sensor module and controlling host are connected to a common network (infrastructure network).
- The R&S NRPM3N LAN sensor module and controlling host are connected only over the switch (peer-to-peer network).

For both connections, the common network or the peer -to-peer connection over the switch, you address the sensor module as follows:

- [Chapter 6.3.5.1, "Using hostnames"](#), on page 55
- [Chapter 6.3.5.2, "Assigning the IP address"](#), on page 56

#### To set up a network Ethernet connection

1. Connect the sensor module as described in [Chapter 6.3.4, "Using the LAN connection"](#), on page 50.

By default, the R&S NRPM3N uses dynamic TCP/IP configuration (DHCP) and obtains the address information automatically.

If both network status LEDs light up in green color, the connection of the R&S NRPM3N to the network is established successfully.

**Note:** Establishing a connection can take up to 2 minutes.

2. If the network status LEDs indicate another state, no connection is possible. For reasons and possible solutions, see:
  - ["Power over Ethernet status LED \(8\)"](#) on page 31
  - ["Network status LED \(5\)"](#) on page 31
  - ["To check the network connection"](#) on page 54

#### Troubleshooting for peer-to-peer connections

##### To check the network connection

1. Check that the assigned IP address of the used network adapter starts with 169.254. The IANA (Internet assigned numbers authority) has reserved the range 169.254.0.0 to 169.254.255.255 for the allocation of automatic private IP addresses (APIPA). Addresses from this range are guaranteed to cause no conflicts with any routable IP address.
2. Try to establish a connection to the R&S NRPM3N with both the default host-name and the hostname extended with `.local`, for example:

## Connecting an R&amp;S NRPM OTA power measurement

```
nrpm3n-101441  
nrpm3n-101441.local
```

### 6.3.5.1 Using hostnames

In a LAN that uses a domain name system (DNS) server, each connected computer or instrument can be accessed via an unambiguous hostname instead of an IP address. The DNS server translates the hostname to the IP address. Using the hostname is especially useful when a DHCP server is used, as a new IP address can be assigned each time the instrument is restarted.

Each sensor module is delivered with a default hostname assigned. You can change the default hostname.

#### Default hostname

The default hostname follows the syntax:

`<device name>-<serial number>`, where:

- `<device name>` is the short name of your sensor module.  
For example, the `<device name>` of R&S NRPM3N is `nrpm3n`.
- `<serial number>` is the individual serial number of the sensor module. The serial number is printed on the name plate at the rear side of the sensor module. It is part of the device ID printed above the barcode:

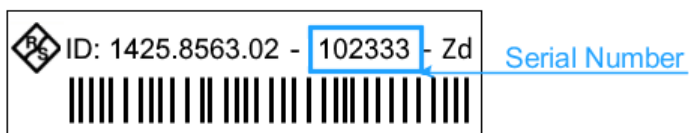

#### Example:

Serial number of the R&S NRPM3N: 102333

Default hostname: NRPM3N-102333

#### Hostname in zero configuration networks, including peer-to-peer networks

The sensor module supports zero configuration networking, used in networks without DHCP server, such as peer-to-peer networks. Thus, you can connect the sensor module to a network without setting up services such as dynamic host configuration protocol (DHCP) and domain name system (DNS), or configuring the network settings manually.

## Connecting an R&amp;S NRPM OTA power measurement

For establishing a connection to the sensor module, try the default hostname and the hostname extended with `.local` as shown in the example below. All communication for resolving names in the top-level-domain (TLD) `.local` are defined to be executed using dedicated local services and ports if no other DNS (domain name server) is available.

**Example:**

Default hostname: `nrpm3n-102333`

Extended hostname: `nrpm3n-102333.local`

**6.3.5.2 Assigning the IP address**

Depending on the network capabilities, the TCP/IP address information for the R&S NRPM3N LAN sensor module can be obtained in different ways:

- If the network supports dynamic TCP/IP configuration using the dynamic host configuration protocol (DHCP), the address information can be assigned automatically.
- If the network does not support DHCP, the R&S NRPM3N LAN sensor module tries to obtain the IP address via the zeroconf (APIA) protocol. If this attempt does not succeed or if the instrument is set to use alternate TCP/IP configuration, the IP address must be set manually.

**Use hostnames to identify the sensor module**

In networks using a DHCP server, it is recommended that you address the sensor module by its unambiguous hostnames, see [Chapter 6.3.5.1, "Using hostnames"](#), on page 55.

A *hostname* is a unique identifier of the sensor module that remains permanent as long as it is not explicitly changed. Hence, you can address a sensor module by the same identification, irrespectively if a network or a point-to-point connection is used.



## 6.4 Starting the measurement

### To start the measurement

To start an R&S NRPM OTA power measurement, it is assumed that all components of the test setup are connected.

An easy way for configuring the measurement and displaying results is given by the R&S Power Viewer software:

- ▶ Start the R&S Power Viewer application, see ["To start the application"](#) on page 60.

The R&S Power Viewer identifies sensor modules that are connected to USB automatically. If you are working with an R&S NRPM3N network sensor module, define the corresponding network connection in the R&S Power Viewer "Sensor' > VISA Connection" dialog, before you start a measurement.

# 7 Performing measurements

## 7.1 Sensor module readings

The antenna modules R&S NRPM-A90 and R&S NRPM-A90D have an integrated diode detector each that converts the RF signal and transmits it directly to the sensor module.

You can measure the power of the incident electromagnetic wave towards the antenna module in various quantities:

- Equivalent isotropically received power  $P_{ISO} = P_i$  in W or dBm (default):  
Equivalent detected power of an isotropic antenna with an ideal power detector at the phase center location of the antenna module assuming radiation only from boresight direction.
  - Power at the internal RF detector in W or dBm: The measurement result without including antenna gain and frequency-dependent calibration factors.  
 $P_{Det} = (G_{RF,i} / k_{att,A,i}(f)) \cdot P_{ISO}$
  - Power density  $S$  in  $W/m^2$ , calculated as:  
 $S = (4\pi/\lambda^2) \cdot P_{ISO}$
  - Electric field strength  $E_{eff}$  in V/m, calculated as:  
 $E_{eff} = \sqrt{S \cdot Z_0}$  with:  $Z_0 = 376.73 \Omega$ .
  - Magnetic field strength  $H_{eff}$  in A/m, calculated as:  
 $H_{eff} = \sqrt{S / Z_0}$  with:  $Z_0 = 376.73 \Omega$ .
- To convert the data, use the remote command:  
`CALCulate:MATH[:EXPRession]` on page 151

## 7.2 Measurement applications

For power measurement with the R&S NRPM3(N), you can either use the PC application R&S Power Viewer, the WebGUI (Web Browser-Based User Interface) or an application that supports direct remote control of the sensor module.

The following sections introduce the power measurement with the R&S Power Viewer and the WebGUI (web browser-based user interface). Section [Chapter 11, "Programming examples"](#), on page 187 describes the corresponding programming examples for working in remote control mode. See the R&S Power Viewer manual for more information on how to use the various functions of the application.

The descriptions refer to the applications running on an MS Windows system. It is assumed, that the measurement is set up, and the required software and drivers are installed on the PC.

## 7.2.1 Using R&S Power Viewer

This section shows how to start the application and access the settings relevant for OTA measurements.

For handling and using the tool in detail, see the "R&S Power Viewer Software Manual" that comes with the installation, see [Chapter 4.6.3, "R&S Power Viewer installation"](#), on page 27. The software manual describes also how to install and use the application on Linux or macOS operating systems.

The R&S Power Viewer supports measuring the received signals of up to 12 antenna modules, and enables you, to perform simultaneous OTA measurements of four sensor module, each transmitting the readings of up to three antenna modules.

The R&S Power Viewer provides the following measurement modes for OTA measurements:

- "OTA Single"  
Evaluates the continuous average power of up to 3 antenna module signals measured by an R&S NRPM3(N).  
Controls one R&S NRPM3(N) sensor module, i.e. you can measure the continuous average power of up to 3 antenna module signals.
- "OTA Multi Sensor"  
Supports the measurements of up to four sensor modules, i.e. you can measure the continuous average power of up to 12 antenna module signals.
- "OTA Trace Measurement"  
Controls one sensor module, i.e. you can measure the power of up to 3 antenna module signals in trace mode.

Outlined are:

- [To start the application.](#)
- [To configure an OTA single sensor ContAV measurement](#), for using the R&S NRPM3(N) with up to three antenna modules.
- [To configure an OTA multi sensor ContAV measurement](#), for using of up to four sensor modules with up to three antenna modules each.
- [To configure an OTA single sensor trace power measurement](#), for using the sensor module with up to three antenna modules.

### To start the application

- ▶ In the MS Windows start menu, select "Start" > "R&S Power Viewer" > "Power Viewer".

The application starts. It provides buttons for OTA measurements in the toolbar.



### To configure an OTA single sensor ContAV measurement



1. In the toolbar, select the "OTA Single" button to open the panel for the OTA measurements with one R&S NRPM3(N).

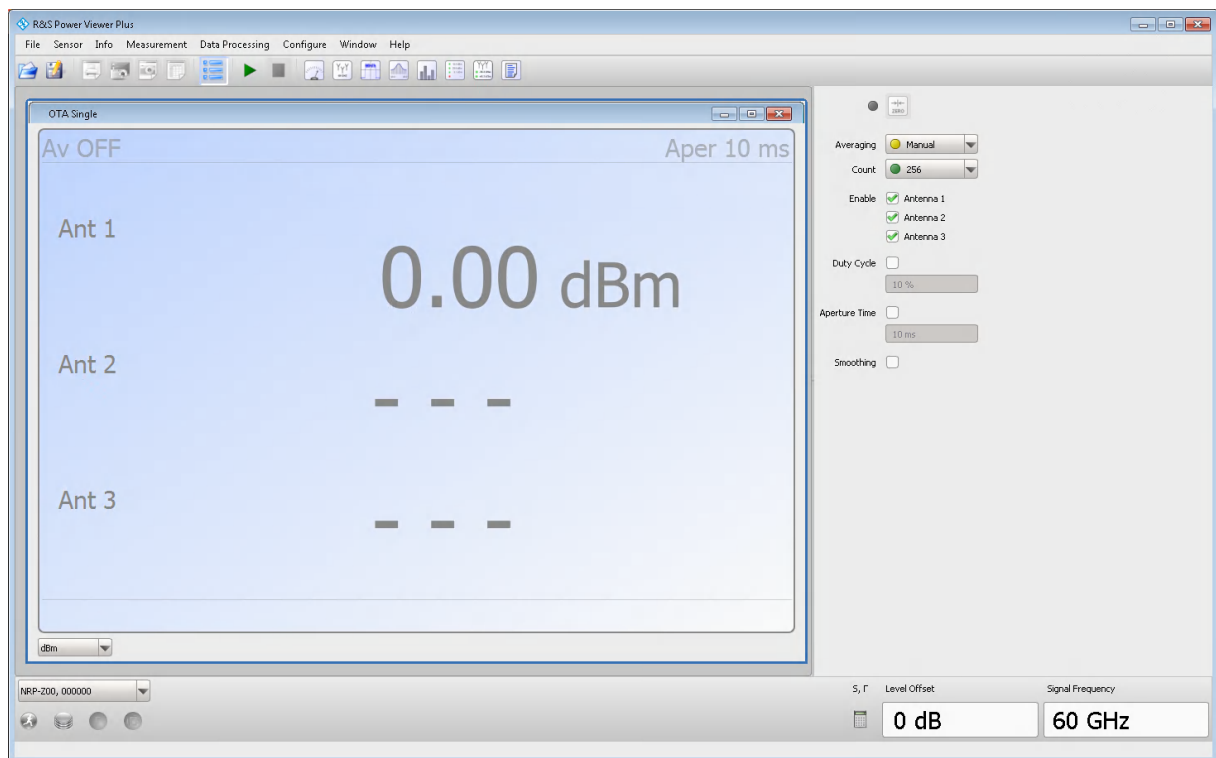

2. In the lower border toolbar, select the sensor module.
3. Execute zeroing:
 

**Note:** Turn off all measurement power signals before zeroing. An active measurement during zeroing causes an error.

  - a) Turn off the measurement signal.
  - b) Select "Sensor > Zero (Signal off)".

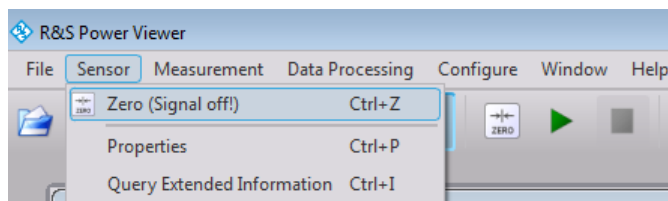

4. In the panel on the right, select the antenna modules for the measurement.
5. If necessary, set the parameters to configure the continuous average power measurement.
6. Set the frequency.
7. Start the measurement.

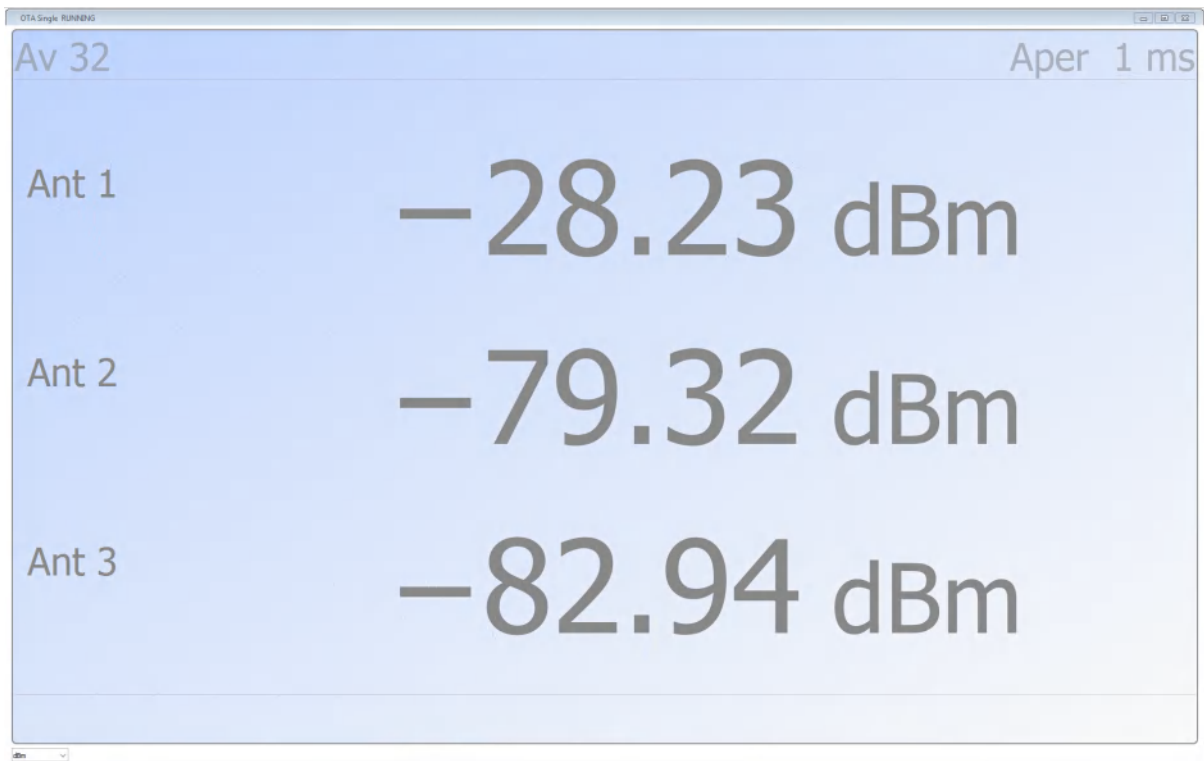

The measurement results window displays measured power in the sensor module channels.

### To configure an OTA multi sensor ContAV measurement

- 1.

In the toolbar, select the "OTA Multi Sensor" button to open the panel for the OTA measurements with several sensor modules.

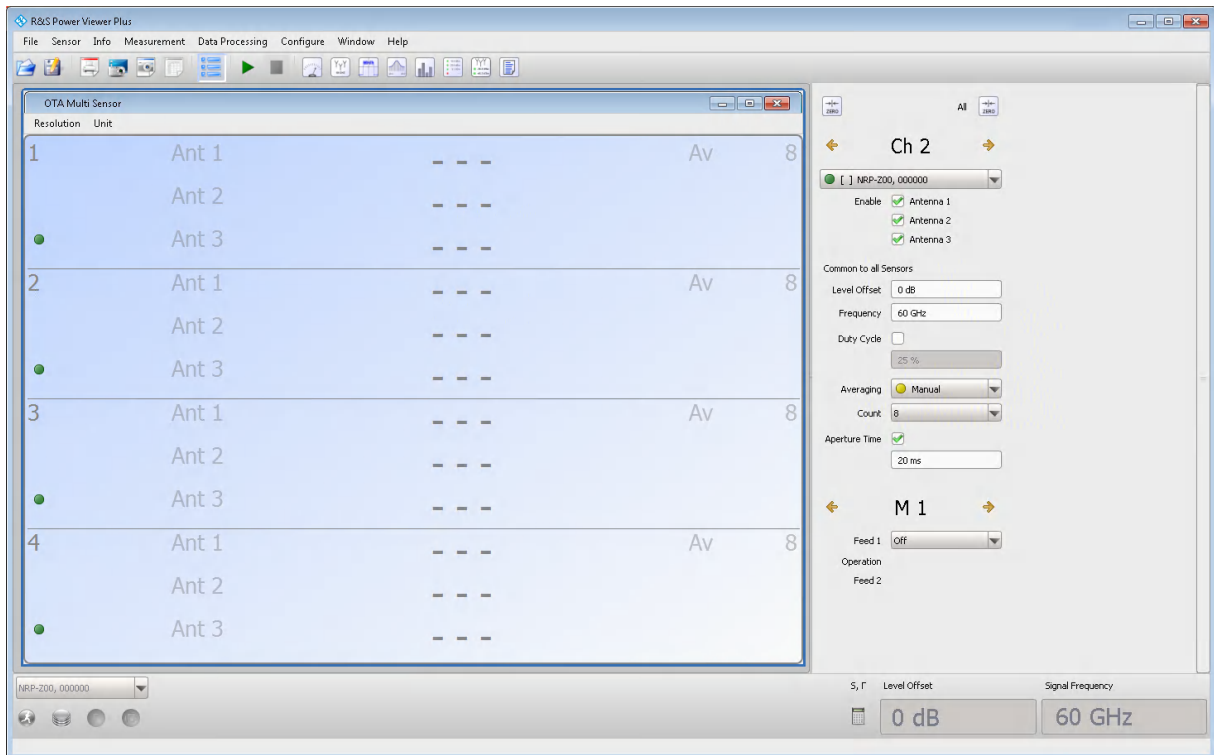

2. In the lower border toolbar, select the sensor module.
3. In the panel on the right, select the channel.
4. Enable the antenna modules of the selected channel.
5. If necessary, set the parameters provided for the measurement mode.
6. Repeat [step 3](#) to [step 5](#) for each channel.
7. Repeat [step 2](#) to [step 6](#) for each connected sensor module.
8. Set the frequency.
9. Start the measurement.



Resolution	Unit			
1	Ant 1	-35.72 dBm	Av	64
NRPM3	Ant 2	-52.73 dBm		
900040	Ant 3	-83.12 dBm		
2	Ant 1	-84.87 dBm	Av	64
NRPM3	Ant 2	-37.72 dBm		
900055	Ant 3	- - -		
3	Ant 1	-28.69 dBm	Av	64
NRPM3	Ant 2	-80.44 dBm		
900056	Ant 3	-83.76 dBm		
Math 1		- - -		
Ch1 A1 /		-7.04 dB		
Ch3 A1		- - -		

The measurement results window displays the results of the multi channel measurement.

### To configure an OTA single sensor trace power measurement

- 1.

In the toolbar, select the button to open the panel for trace measurements.



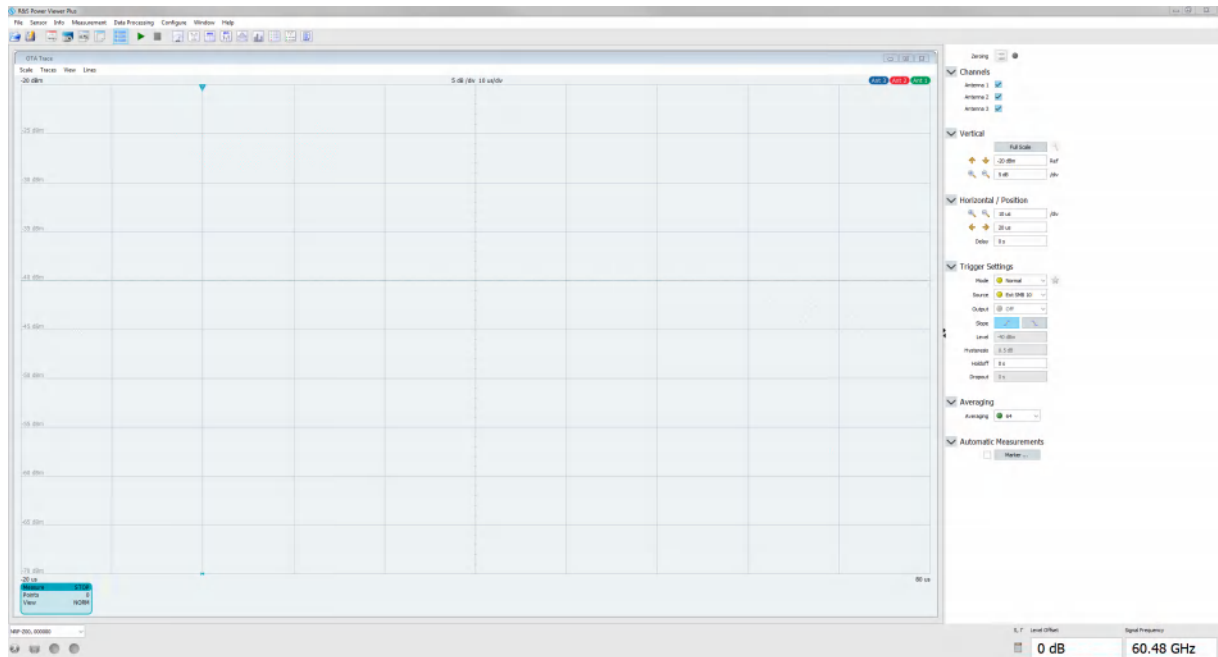

The R&S Power Viewer displays the trace measurement results windows, and the setting parameters in the panel on the right.

2. In the lower border toolbar, select the sensor module.
3. In the panel on the right, select the antenna modules for the measurement.
4. If necessary, adjust the scaling of the measurement results window.
5. If necessary, set the trigger and averaging parameters provided for "Trace" measurements.
6. Set the frequency.
7. Start the measurement.

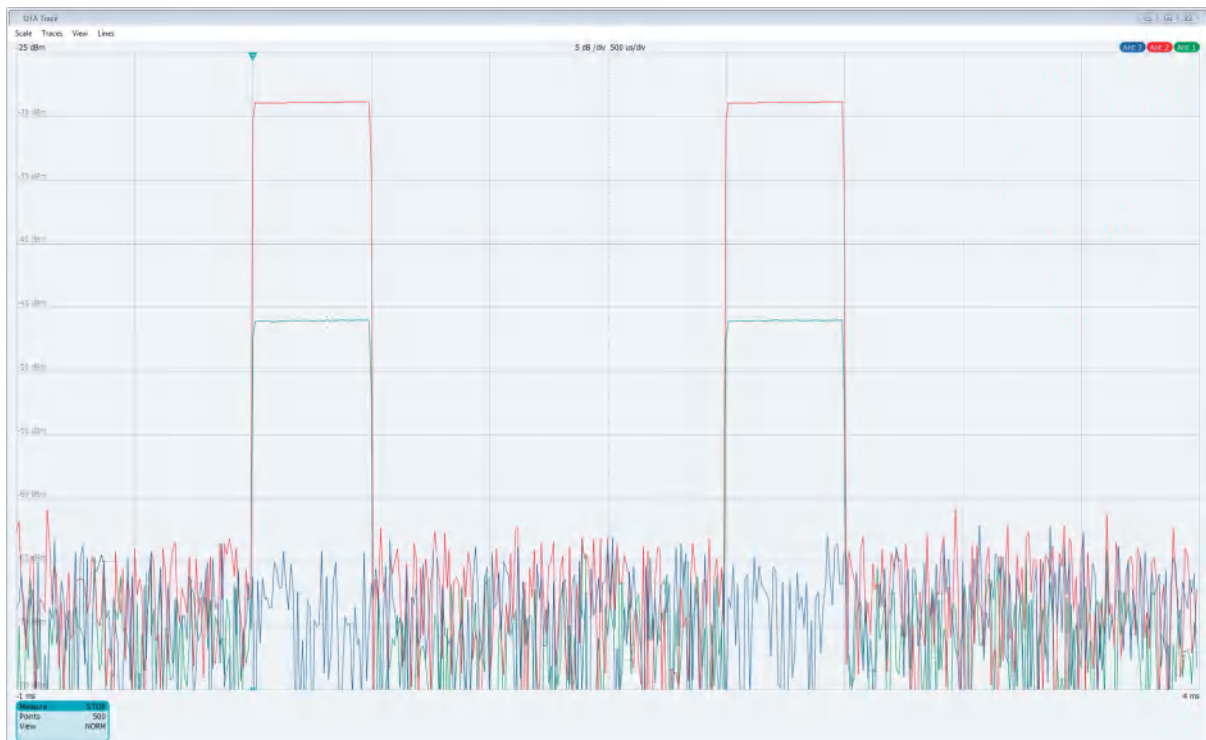

The results window displays the trace measurement results of the three antenna modules.

## 7.2.2 Using the web browser-based user interface

 Requires a sensor module with networking capabilities, a R&S NRPM3N sensor module.

The web browser-based user interface is an alternative way to operate an R&S NRPM3N LAN sensor module. With the integrated, browser-based graphical user interface of the R&S NRPM3N sensor module, you can configure the most common settings and measure in the provided measurement modes.

There is no installation required, except for a web browser installed on the controller device. Supported web browsers are:

- Mozilla Firefox 33 or later
- Google Chrome 36 or later
- Microsoft Internet Explorer 10 or later

- Safari 5.1 or later

You can use the web browser-based user interface with all devices and operating systems, including tablets and smart phones that are connected to the same network.

### Starting a measurement

1. Set up the LAN connection, as described in [Chapter 6.3.4, "Using the LAN connection"](#), on page 50.
2. Open a supported web browser.
3. Enter the instrument name or the IP address of the sensor module you want to connect to.

Example: `http://nrpm3n-990001`

For details on how to find out the IP address or hostname, refer to [Chapter 6.3.5.2, "Assigning the IP address"](#), on page 56 and [Chapter 6.3.5.1, "Using hostnames"](#), on page 55.

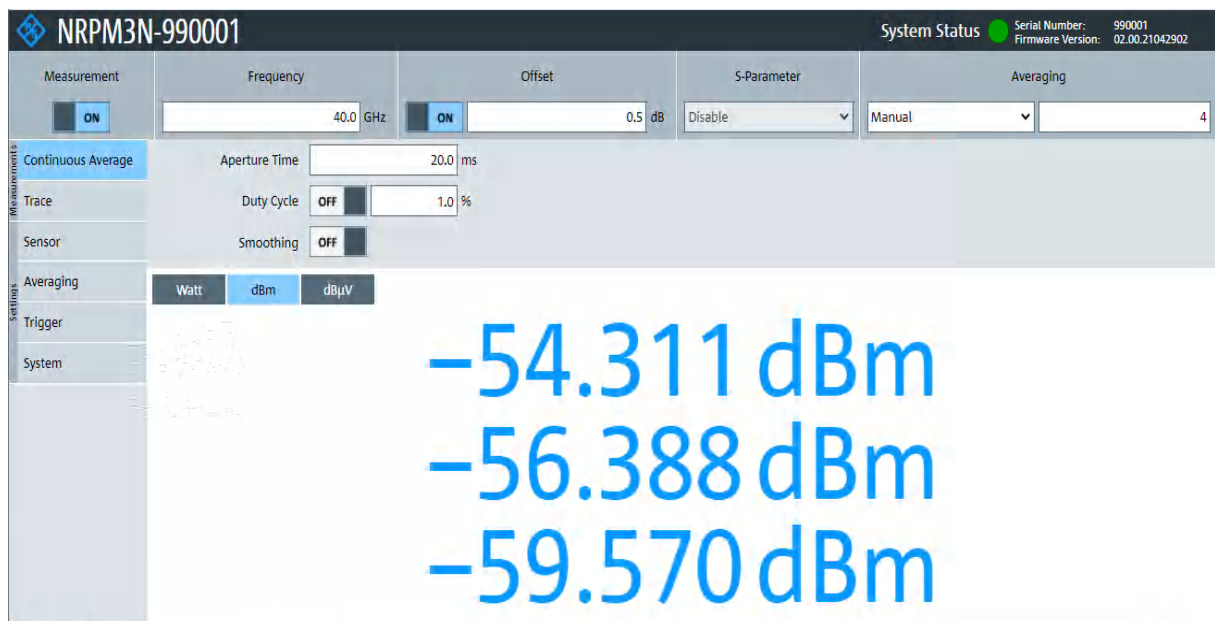

The main dialog of the web browser-based user interface opens.

4. In the "Measurements" navigation pane, select "Continuous Average".
5. Enter your settings.
6. Select "Measurement > ON" to start the measurement.

The following chapters describe the functions and parameters of the web browser-based user interface in detail.

- [Main dialog of the web browser-based user interface](#).....68
- [Setting the unit](#)..... 69
- [Common settings](#)..... 70
- [Measurement modes](#)..... 72
- [Settings](#)..... 74
- [System settings](#)..... 79

### 7.2.2.1 Main dialog of the web browser-based user interface

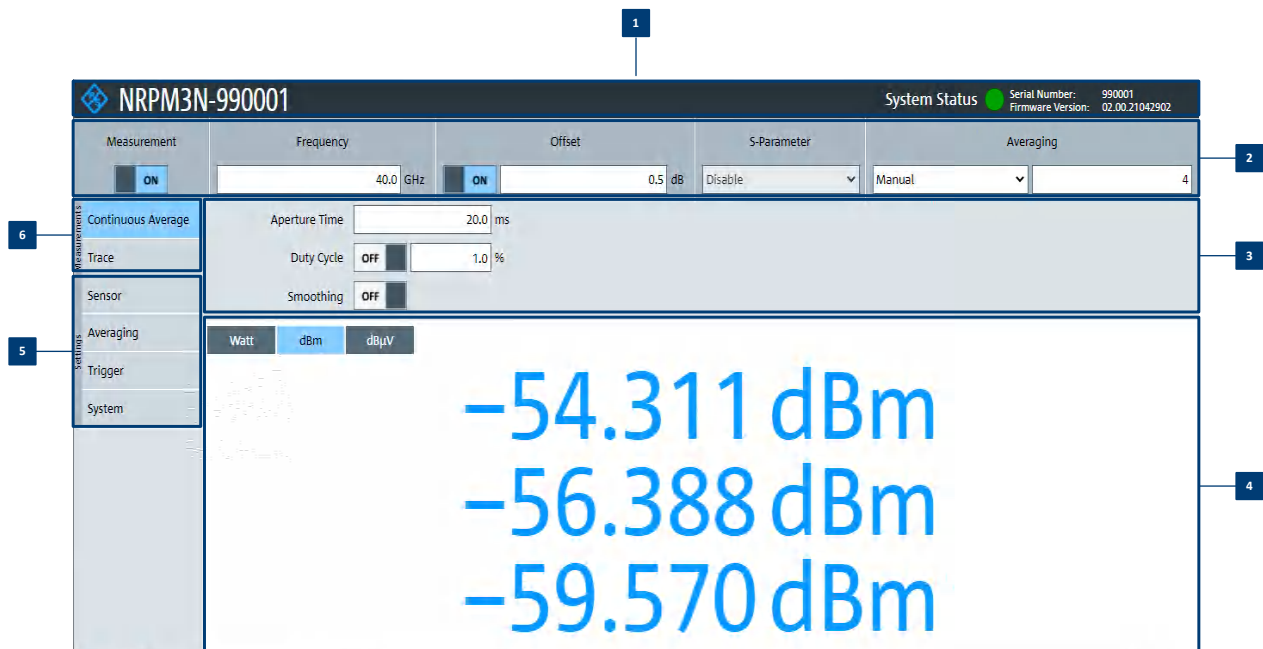

**Figure 7-1: Explanation of the web browser-based user interface**

- 1 = Title bar
- 2 = Common settings, see [Chapter 7.2.2.3, "Common settings"](#), on page 70
- 3 = Parameters pane
- 4 = Result pane
- 5 = "Settings" navigation pane, see [Chapter 7.2.2.5, "Settings"](#), on page 74
- 6 = "Measurements" navigation pane, see [Chapter 7.2.2.4, "Measurement modes"](#), on page 72

The title bar shows the following information:

- Hostname, see [Chapter 6.3.5.1, "Using hostnames"](#), on page 55.
- System status, see ["Status LED \(2\)"](#) on page 30.

The parameters pane provides the setting parameters for the corresponding function selected in the navigation pane.

The result pane displays the measurement readings either numerically or graphically, depending on the selected measurement mode.

### 7.2.2.2 Setting the unit

You can set the unit for the different parameters by typing the corresponding letter after the entered value.

#### Example:



**Figure 7-2: Parameter**

- 1 = Parameter name
- 2 = Value
- 3 = Unit

The following abbreviations are available:

Unit	Keyboard key
Decibel	<i>d</i>
Hertz	<i>h</i>
Second	<i>s</i>
Volt	<i>v</i>
Watt	<i>w</i>

Unit multiples	Keyboard key
Giga	<i>g</i>
Mega	<i>m</i>
Kilo	<i>k</i>
milli	<i>m</i>

Unit multiples	Keyboard key
micro	<i>u</i>
nano	<i>n</i>

**Example:**

To set the unit to 1 GHz, enter *1g*.

For certain units, you can select a different representation, depending on the requirements. For example, for the representation of the "Trigger Level", you can choose Watt, dBm or dB $\mu$ V. To change the unit, you must specify the desired value together with the full new unit once.

**Example:**

To change the representation of a "Trigger Level" of 100 $\mu$ W into dBm, enter *-10dbm* in the "Trigger Level" field. All future entries of solely numbers represent the value in dBm. If you enter *-15* in the field, the "Trigger Level" value is set to -15.00 dBm.

If you want to revert the value to Watt, enter *50uW*. The "Trigger Level" value is set a value of 50.00  $\mu$ W, thus changing the unit for the further numeric entries.

**7.2.2.3 Common settings**

Describes common measurement settings that are available for all measurement modes.

Access:

- In the common settings pane of the web browser-based user interface main dialog, select the corresponding parameter.



The remote commands required to define the common settings are described in:

- [Chapter 10.9, "Starting and ending a measurement"](#), on page 170
- [Chapter 10.8.3, "Configuring corrections"](#), on page 168

System Status.....	71
Measurement.....	71
Frequency.....	71
Offset.....	71
L <State>.....	71
L <Value>.....	71
S-Parameter.....	72
Averaging.....	72

### System Status

Displayed in the title bar. Confirms that there is a connection between the sensor and the remote computer and that the sensor is recognized by the software.

The presentation of this symbolic LED mirrors the physical LED of the sensor, see "Status LED (2)" on page 30.

### Measurement

Activates the measurement.

Remote command:

`INITiate:CONTinuous` on page 172

### Frequency

Sets the carrier frequency of the applied signal. This value is used for frequency-response correction of the measurement result.

Remote command:

`[SENSe<Sensor>:]FREQuency` on page 168

### Offset

Sets and enables a level offset.

#### <State> ← Offset

Activates the level offset.

Remote command:

`[SENSe<Sensor>:]CORRection:OFFSet:STATe` on page 170

#### <Value> ← Offset

Adds a fixed level offset in dB to account for external losses.

Remote command:

`[SENSe<Sensor>:]CORRection:OFFSet` on page 170

**S-Parameter**

**Note:** S-parameter compensation is not supported by the R&S NRPM3 sensor modules.

**Averaging**

See [Chapter 10.8.1, "Configuring averaging"](#), on page 165.

**7.2.2.4 Measurement modes**

Provides the parameters for the supported measurement modes.

- [Continuous Average mode](#).....72
- [Trace mode](#).....73

**Continuous Average mode**

Describes the parameters of the continuous average measurement.

Access:

- ▶ In the measurement navigation pane of the web browser-based user interface, select "Continuous Average".

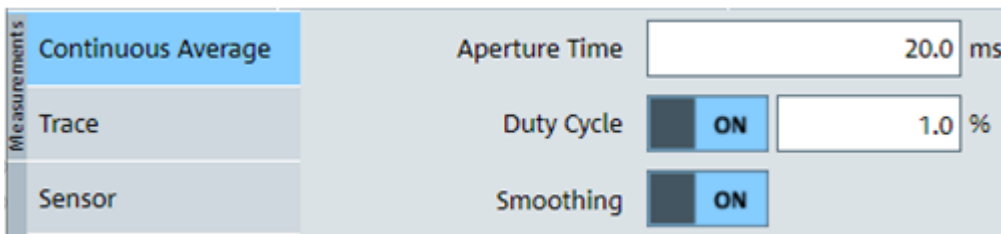

The remote commands required to define the continuous average settings are described in [Chapter 10.7.1, "Configuring a continuous average measurement"](#), on page 153.

- [Aperture Time](#).....72
- [Duty Cycle](#).....73
- [Smoothing](#).....73

**Aperture Time**

Sets the aperture time, the width of the sampling windows.

Remote command:

[\[SENSe<Sensor>:\] \[POWer:\] \[AVG:\] APERture](#) on page 154



## Duty Cycle

Sets the duty cycle, the percentage of one period during which the signal is active, for pulse modulated signals. If activated, the sensor calculates the signal pulse power from its value and the average power.

Remote command:

[SENSE<Sensor>:]CORREction:DCYCLE:STATe on page 169

[SENSE<Sensor>:]CORREction:DCYCLE on page 169

## Smoothing

Activates the smoothing filter, a steep-cut off digital lowpass filter. The filter reduces result fluctuations caused by modulation.

Remote command:

[SENSE<Sensor>:] [POWer:] [AVG:] SMOothing:STATe on page 156

## Trace mode

Provides the parameters of the trace measurement.

Access:

- In the measurement navigation pane of the web browser-based user interface main dialog, select "Trace".

Measurements	Continuous Average	Trace Time	<input type="text" value="10.0"/> ms
	Trace	Trace Offset Time	<input type="text" value="500.0"/> ms
	Sensor	Trace Points	<input type="text" value="260"/>

The remote commands required to define the trace settings are described in [Chapter 10.7.3, "Configuring a trace measurement"](#), on page 157.

Trace Time.....	73
Trace Offset Time.....	74
Trace Points.....	74

## Trace Time

Sets the trace length.

Remote command:

[SENSE<Sensor>:] TRACe:TIME on page 164

### Trace Offset Time

Sets the relative position of the trigger event in relation to the beginning of the trace measurement sequence. Used to specify the start of recording for the trace mode.

Remote command:

[SENSE<Sensor>:] TRACe:OFFSet:TIME on page 163

### Trace Points

Sets the number of required values per trace sequence. For achieving a good optimum between the measurement speed and the resolution, you can set a value of, e.g. 200 trace points.

Remote command:

[SENSE<Sensor>:] TRACe:POINTs on page 163

## 7.2.2.5 Settings

Describes the parameters for general configuration.

- [Sensor settings](#)..... 74
- [Averaging settings](#)..... 76
- [Trigger settings](#)..... 77

### Sensor settings

Provides the parameters for optimizing the measurement results for specific measurement requirements.

Access:

- ▶ In the settings navigation pane of the web browser-based user interface, select "Sensor".



The remote commands required to define the sensor settings are described in:

- [Chapter 10.4.2, "Handling of available antenna modules"](#), on page 134
- [Chapter 10.8.3, "Configuring corrections"](#), on page 168
- [Chapter 10.13, "Calibrating/zeroing the R&S NRPM3\(N\) sensor module"](#), on page 185
- [Chapter 10.12, "Testing the R&S NRPM OTA Power Measurement Solution"](#), on page 184

<a href="#">Antenna</a> .....	75
<a href="#">Zero Calibration</a> .....	75
<a href="#">Sensor Information</a> .....	75

### Antenna

Activates an antenna module module for the measurement.

Remote command:

[\[SENSe<Sensor>:\]CHANnel<Channel>:PRESeNce?](#) on page 134

[\[SENSe<Sensor>:\]CHANnel<Channel>\[:ENABle\]](#) on page 134

### Zero Calibration

Executes zeroing using the signal at the sensor module input, see [Chapter 10.13, "Calibrating/zeroing the R&S NRPM3\(N\) sensor module"](#), on page 185.

#### Note:

Turn off all test signals before zeroing. An active test signal during zeroing causes an error.

Remote command:

[CALibration<Channel>:ZERO:AUTO](#) on page 186

### Sensor Information

Provides information on the R&S NRPM OTA power measurement system.

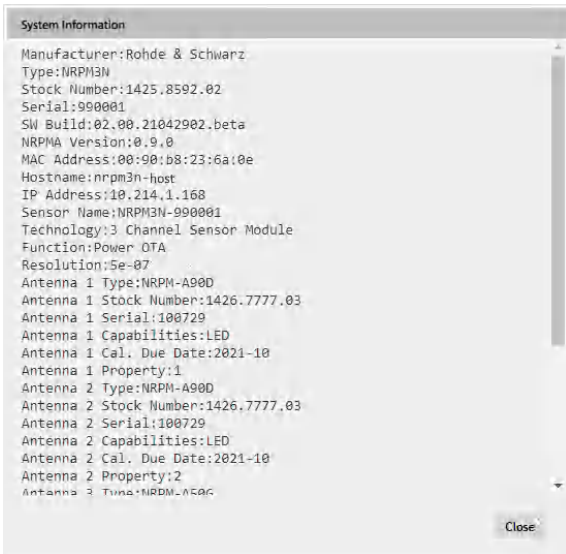

### Averaging settings

Describes the parameters for automatic averaging.

Access:

- In the settings navigation pane of the web browser-based user interface, select "Averaging".

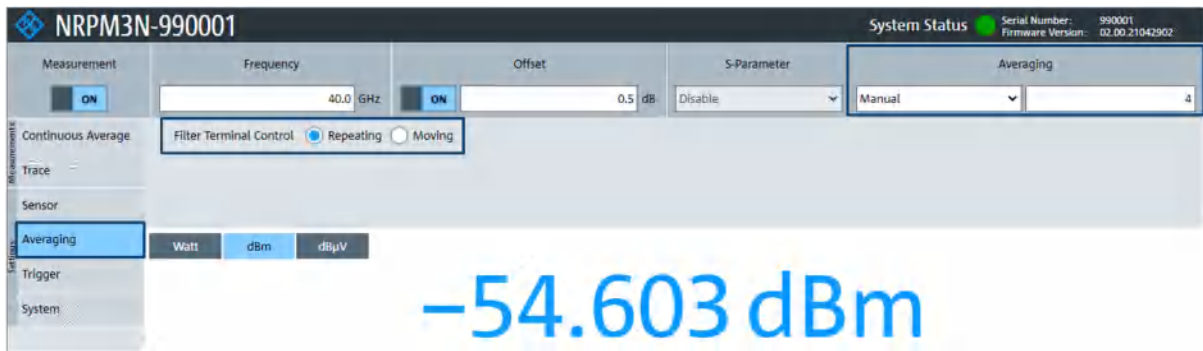

The remote commands required to define the averaging settings are described in [Chapter 10.8.1, "Configuring averaging"](#), on page 165.

Averaging Mode.....	77
L <Mode>.....	77
L <Value>.....	77
Filter Terminal Control.....	77

**Averaging Mode**

Indicates that the R&S NRPM3N works in manual averaging mode and enables you to set the average count, also considered as averaging factor.

See [Chapter 10.8.1, "Configuring averaging"](#), on page 165.

**<Mode> ← Averaging Mode**

Displays the averaging mode.

"manual" Operates in manual mode only.  
Enter the average count under **<Value>**.

Remote command:

[\[SENSe<Sensor>:\]AVERAge\[:STATe\]](#) on page 167

**<Value> ← Averaging Mode**

Sets the average count.

Remote command:

[\[SENSe<Sensor>:\]AVERAge:COUNT](#) on page 166

**Filter Terminal Control**

Defines the output mode for the measurement results, denoted as termination control.

See also [Chapter 10.5, "Controlling the measurement"](#), on page 137.

"Repeating" Provides the measurement result only after the entire measurement has been completed.

The number of measurement cycle repetitions corresponds to the set averaging factor, and thus directly relates to the measurement duration: the higher the averaging factor, the longer measurement time.

"Moving" Provides intermediate values to facilitate early detection of changes in the measured quantity. In the settled state, i.e. when the number of measurements specified by the averaging factor has been performed, the sensor module provides a moving average.

Remote command:

[\[SENSe<Sensor>:\]AVERAge:TCONtrol](#) on page 167

**Trigger settings**

Provides the trigger parameters. You can define the conditions that have to be fulfilled for a triggered measurement.

Access:

- ▶ In the settings navigation pane of the web browser-based user interface, select "Trigger".

Trigger Source	Immediate		Dropout	0.0	s
Trigger Level	600.0	pW	Holdoff	0.0	s
Trigger Delay	0.0	s	Hysteresis	0.0	dB

The remote commands required to define the trigger settings are described in:

- [Chapter 10.10, "Configuring the trigger"](#), on page 172
- [Chapter 10.5, "Controlling the measurement"](#), on page 137

Trigger Source.....	78
L<Source>.....	78
L<Slope>.....	78
Trigger Level.....	79
Trigger Delay.....	79
Dropout.....	79
Holdoff.....	79
Hysteresis.....	79

### Trigger Source

Selects the source and slope polarity of the trigger signal.

You can use an internal or externally applied trigger signal.

#### <Source> ← Trigger Source

Selects the trigger source, see ["Trigger sources"](#) on page 139.

Remote command:

`TRIGger:SOURCE` on page 178

#### <Slope> ← Trigger Source

Sets the polarity of the active slope of the trigger signal.

"Positive"      Uses the rising edge of the trigger signal.

"Negative"      Uses the falling edge of the trigger signal.

Remote command:

`TRIGger:SLOPe` on page 178

### Trigger Level

Sets the trigger threshold for internal triggering derived from the test signal.

Remote command:

[TRIGger:LEVel](#) on page 176

[TRIGger:LEVel:UNIT](#) on page 177

### Trigger Delay

Sets the delay between the trigger event and the actual start of the measurement.

Remote command:

[TRIGger:DELaY](#) on page 174

[TRIGger:DELaY:AUTO](#) on page 175

### Dropout

With a positive (negative) trigger slope, the dropout time is the minimum time for which the signal must be below (above) the power level defined by [Trigger Level](#).

Remote command:

[TRIGger:DTIME](#) on page 175

### Holdoff

Sets the hold-off time.

After a trigger event, the sensor module suppresses all trigger events that occur within this time period.

Remote command:

[TRIGger:HOLDoff](#) on page 176

### Hysteresis

Sets the hysteresis in dB. A trigger event occurs, if the trigger level:

- Falls below the set value on a rising slope.
- Rises above the set value on a falling slope.

Thus, you can use this setting to eliminate the effects of noise in the signal for the edge detector of the trigger system.

Remote command:

[TRIGger:HYSTeresis](#) on page 176

## 7.2.2.6 System settings

Provides the parameters of the general network environment and specific identification parameters of the sensor module in the network.

Access:

- In the settings navigation pane of the web browser-based user interface, select "System".

IP Address	<input type="text" value="10.214.1.168"/>	Gateway	<input type="text" value="10.214.0.1"/>	
Subnet Mask	<input type="text" value="255.255.252.0"/>	DHCP	<input checked="" type="radio"/> Auto <input type="radio"/> Static	<input type="button" value="Apply Network Settings"/>
Sensor Name	<input type="text" value="NRPM3N-990001"/>		<input type="button" value="Selftest"/>	<input type="button" value="Firmware Update..."/>

The remote commands required to define the system settings are described in [Chapter 10.4.1, "Configuring the system"](#), on page 120.

<a href="#">IP Address</a> .....	80
<a href="#">Subnet Mask</a> .....	80
<a href="#">Gateway</a> .....	80
<a href="#">DHCP</a> .....	81
<a href="#">Apply Network Settings</a> .....	81
<a href="#">Sensor Name</a> .....	81
<a href="#">Update</a> .....	81
<a href="#">Selftest</a> .....	81

### IP Address

Sets the IP address of the sensor module.

Remote command:

`SYSTEM:COMMunicate:NETWork:IPADdress` on page 121

### Subnet Mask

Sets the subnet mask.

The subnet mask consists of four number blocks separated by dots. Every block contains 3 digits at a maximum.

Remote command:

`SYSTEM:COMMunicate:NETWork:IPADdress:SUBNet:MASK` on page 122

### Gateway

Sets the address of the default gateway that means the router that is used to forward traffic to destinations beyond the local network. This router is on the same network as the instrument.

Remote command:

`SYSTEM:COMMunicate:NETWork:IPADdress:GATeway` on page 121



## DHCP

Selects the mode for assigning the IP address.

"Auto" Assigns the IP address automatically, provided the network supports DHCP (dynamic host configuration protocol).

"Static" Enables you to assign the IP address manually.

Remote command:

`SYSTem:COMMunicate:NETWork:IPADdress:MODE` on page 122

## Apply Network Settings

After you have completed the required network settings changes, confirm the modification with "Apply Network Settings".

## Sensor Name

Assigns a name for the sensor module. The web browser-based user interface indicates the name in the title bar, see [Figure 7-1](#).

If you do not specify a sensor name, the hostname is used as default, see `SYSTem:COMMunicate:NETWork[:COMMON]:HOSTname` on page 124.

Remote command:

`SYSTem[:SENSor]:NAME` on page 134

## Update

Opens a dialog to start the firmware update. For further information, see [Chapter 8.2.2, "Using the web browser-based user interface"](#), on page 86.

Alternatively, you can update the firmware with the firmware update for R&S NRP family program, see [Chapter 8.2.1, "Using the firmware update for R&S NRP family program"](#), on page 84, or even remotely, see [Chapter 8.2.3, "Using remote control"](#), on page 87.

Remote command:

`SYSTem:FWUPdate` on page 126

`SYSTem:FWUPdate:STATus?` on page 127

## Selftest

Initiates a selftest of the sensor.

### Note:

Do not apply a signal to the sensor module while the selftest is running.

Executing the self-test with an active signal assigned, can erroneously result in error messages at the test steps *Offset Voltages* and/or *Noise Voltages*.

When completed, the web browser-based user interface displays a report with the test results.

```

Self Test

Calibration Data:
  Integrity of Factory Calibration Data Set: PASS
  Integrity of Antenna 1 Calibration Data Set: PASS
  Integrity of Antenna 2 Calibration Data Set: PASS
  Integrity of Antenna 3 Calibration Data Set: PASS

Operating Voltages:
  +V3_VCC_MID: PASS (+3.32 V)
  +V8_PS1: PASS (+1.76 V)
  +V8_PS2: PASS (+0.99 V)
  +V3_VCC_13: PASS (+3.32 V)
  +V5_VCC_36: PASS (+2.53 V)
  +V8_VCC_35: PASS (+1.78 V)
  +V8_PL1: PASS (+1.73 V)
  +V8_PL2: PASS (+1.80 V)
  +V8_LPDOR2_CODE: PASS (+1.78 V)
  +V2_LPDOR2: PASS (+1.28 V)
  +V8_VREF_LPDOR2: PASS (+0.63 V)
  +V25_VREF: PASS (+1.26 V)
  +V2_ETHPHY: PASS (+1.27 V)
  +V_ANALOG1: PASS (+3.00 V)
  +V_ANALOG2: PASS (+5.32 V)
  +V_ANALOG3: PASS (+5.15 V)

Supply Antenna Modules
  +V_ANALOG Operating Current: PASS (+9.2 mA)

Temperatures:
  Digital Board Temperature: PASS (+56.6 deg C)
  Analog Board Temperature: PASS (+32.4 deg C)
  Antenna 1 Temperature: PASS (+26.2 deg C)
  Antenna 2 Temperature: PASS (+25.2 deg C)
  Antenna 3 Temperature: PASS (+26.3 deg C)

Offset Voltages:
  Channel 1: PASS (-0.0244 mV, -0.0314 mV)
  Channel 2: PASS (+0.0005 mV, -0.0188 mV)
  Channel 3: PASS (-0.0263 mV, -0.0185 mV)

Noise Voltages:
  Channel 1: PASS (15.9 uV)
  Channel 2: PASS (15.4 uV)
  Channel 3: PASS (12.8 uV)

Digital Wiring:
  Antenna 1: PASS
  Antenna 2: PASS
  Antenna 3: PASS

Analog Wiring:
  Antenna 1: PASS
  Antenna 2: PASS
  Antenna 3: PASS
  
```

Close

Remote command:

`TEST:SENSoR?` on page 184

# 8 Firmware update

- [Hardware and software requirements](#)..... 83
- [Updating the firmware](#)..... 83

## 8.1 Hardware and software requirements

To perform a firmware update, you need:

- Connectors and cables for establishing a connection to the PC, see [Chapter 6.3.2, "Connecting to the controller PC"](#), on page 46.
- Rohde & Schwarz update file (\*.rsu) for the power sensor  
Download the most recent firmware version from the Rohde & Schwarz home-page on the Internet. The latest firmware update files are available at:  
[www.rohde-schwarz.com/software/nrpm/](http://www.rohde-schwarz.com/software/nrpm/).  
If the \*.rsu file is packed in a \*.zip archive, extract it before updating.
- If you use the firmware update for R&S NRP family program, further requirements are essential, see ["Checking the prerequisites"](#) on page 84.

## 8.2 Updating the firmware

You have several options to update the firmware installed on an R&S NRPM3(N) sensor module. A firmware update can take up to 5 minutes.

---

### **NOTICE**

#### **Potential damage to the firmware of the device**

Disconnecting the power supply while an update is in progress leads to missing or faulty firmware.

Take special care not to disconnect the power supply while the update is in progress. Interrupting the power supply during the firmware update will most likely lead to an unusable sensor module which needs to be sent in for maintenance. Make sure that the update is not interrupted.

---

## Updating the firmware

- [Using the firmware update for R&S NRP family program](#)..... 84
- [Using the web browser-based user interface](#)..... 86
- [Using remote control](#)..... 87

## 8.2.1 Using the firmware update for R&S NRP family program

The Firmware update for R&S NRP family program is part of the R&S NRP Toolkit, see [Chapter 4.6.2, "R&S NRP Toolkit installation"](#), on page 24.

### Checking the prerequisites

To make sure that you have fulfilled all prerequisites:

1. **Note:** You can update the firmware with firmware update for R&S NRP family, when the sensor module is recognized as a VISA device.  
Make sure that a recent VISA software is installed on the computer.
2. Make sure that the R&S NRP Toolkit for MS Windows is installed on the computer, see [Chapter 4.6.2, "R&S NRP Toolkit installation"](#), on page 24.

### Firmware update for R&S NRP family

It is assumed, that you have checked and fulfilled the prerequisites.

To update the firmware:

1. Connect the sensor module to the computer as described in [Chapter 6.3.2, "Connecting to the controller PC"](#), on page 46.
2. Start the firmware update for R&S NRP family program:  
"Start" menu > "NRP-Toolkit" > "Firmware Update".



The program starts scanning for Rohde & Schwarz sensor modules connected over USB.

When the scan is completed, it lists all recognized sensor modules under "Device".

## Updating the firmware

3. If the sensor module you want to update is not listed, perform one of the following actions:
  - a) Make sure the sensor module is physically connected.
  - b) Select "Rescan". This function starts a new search for sensor modules.

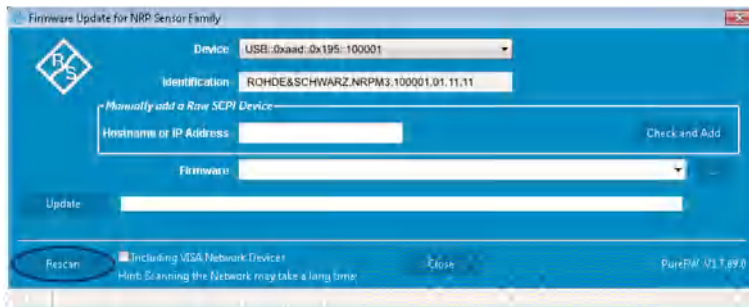

- c) Check whether all necessary drivers are installed on the computer. For example, if the VISA library is not installed on the computer, no VISA sensor modules is accessible. See also "[Troubleshooting](#)" on page 86.

4. Select the sensor module you want to update in the "Device" list.

**Note:** The "Hostname or IP Address" field is not used during this procedure. Therefore, leave it empty.

5. In the "Firmware" field, enter the full path and filename of the update file, or press the browse button next to the field and select it.

If you have updated the firmware on your sensor module before, path and filename are displayed. New firmware for the Rohde & Schwarz sensor modules generally has an \*.rsu (Rohde & Schwarz update) extension.

6. Select "Update".

During the update process, the program displays a progress bar and information on the current state. The update sequence can take a couple of minutes.

7. Check if the update was successful. The firmware version in the "Identification" field must match the version you selected in the "Firmware" field.



## Troubleshooting

### R&S NRPM3N LAN sensor module not detected

You do not find the sensor module in the list of sensor modules provided by firmware update for R&S NRP family.

The driver assigned to the sensor module is the legacy driver.

- ▶ Install a recent VISA software.

### Exclamation mark denotes a discrepancy

The sensor module is highlighted by a yellow exclamation mark in the Windows device manager.

Windows tries in vain to find a USB driver for the sensor module.

- ▶ Install a recent VISA software.

### Firmware update failed

If the update was not successful:

1. Check whether all necessary drivers are installed on the computer.  
For example, if the VISA library is not installed, no VISA power sensor is accessible.
2. Check if the VISA software is up-to-date.
3. Install the corresponding driver or VISA software.

For further information, see:

- [Chapter 8.1, "Hardware and software requirements"](#), on page 83
- ["Checking the prerequisites"](#) on page 84
- [Chapter 12.3, "Problems during a firmware update"](#), on page 204

## 8.2.2 Using the web browser-based user interface

1. Connect the sensor module to the computer as described in [Chapter 6.3.4, "Using the LAN connection"](#), on page 50.
2. Open the web browser-based user interface as described in [Chapter 7.2.2, "Using the web browser-based user interface"](#), on page 66.

3. In the navigation pane, select "System".
4. Select "Firmware Update".
5. In the "Firmware Update" dialog, select "Select RSU file".
6. In the file browser, select the \*.rsu file for upload.

The dialog displays the selected file with file size and status.

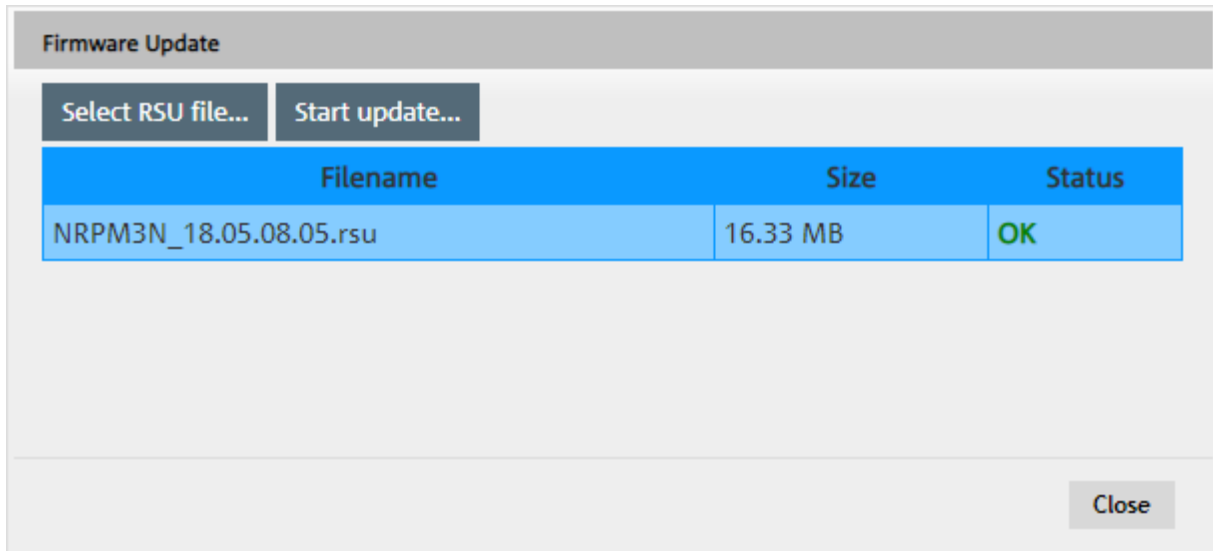

7. Select "Start update".

During the update process, the program displays a progress bar and information on the current state. The update sequence can take a couple of minutes. When completed, the dialog closes automatically.

### 8.2.3 Using remote control

If you want to integrate a firmware update function in an application, use `SYSTem:FWUPdate` on page 126.

#### Example:

You want to update your R&S NRPM3N with the `nrpm3n_FW_18.05.08.05.rsu` file. This file has a size of 10242884 bytes.

To send the file to the sensor for updating the firmware, your application has to assemble a memory block containing:

```
SYST:FWUP <block_data>
```

The `<block_data>` are definite length arbitrary block data as described in `SYSTem:FWUPdate` on page 126.

The size of the file is 10242884. This number has 8 digits. Thus, the `<block_data>` consist of the following:

- #
- 8  
How many digits follow to specify the file size.
- 10242884  
Number that specifies the file size.
- `<file_contents>`  
Contents of the `*.rsu` file, byte-by-byte
- 0x0a  
Delimiter

In this example, you write exactly 10242905 bytes to the sensor module, for example by using a `'viWrite()'` function.

The 10242905 bytes result from the values of the list above:

$$9 + 1 + 1 + 1 + 8 + 10242884 + 1$$

In a (pseudo) string notation, the memory block looks as follows:

```
SYST:FWUP #810242884<file_contents>0x0a
```



## 9 Network and remote operation

In addition to controlling an R&S NRPM3(N) sensor module on a PC application, you can operate and control it with an application that supports direct remote control from a remote PC.

The following sections contain product-related information on remote control of the R&S NRPM3(N) sensor module. The information applies to all applications and operating modes.

 For general information on remote control of Rohde & Schwarz products using SCPI commands, refer to [Remote control via SCPI](#).

### 9.1 Remote control interfaces and protocols

Remote control of sensor modules enables you to integrate them into custom automatic test equipment (ATE) systems. For remote control communication between the R&S NRPM and the controlling host, you can use various interfaces and protocols to establish the connection.

Depending on the sensor module model, the sensor modules support the following interfaces:

- R&S NRPM3 sensor modules support USB access.
- R&S NRPM3N sensor modules support Ethernet or USB access.

[Table 9-1](#) lists the protocols you can use for the corresponding interfaces.

Table 9-1: Remote control interfaces and protocols

Interface	Supported by	Protocols, VISA <sup>(*)</sup> address string and library
USB	R&S NRPM3 R&S NRPM3N	<b>USBTMC</b> USB:: <vendor id="">::&lt;product ID&gt;:: &lt;serial number&gt;[::INSTR] VISA</vendor>
Ethernet	R&S NRPM3N	<ul style="list-style-type: none"> <li>• <b>VXI-11</b> TCPIP::host address[::LAN device name][:: INSTR] VISA</li> <li>• <b>HiSLIP</b> high-speed LAN instrument protocol (IVI-6.1) TCPIP::host address::hislip0[::INSTR] VISA</li> <li>• <b>Socket communication (LAN Ethernet)</b> TCPIP::host address[::LAN device name]:: &lt;port&gt;::SOCKET</li> </ul>
<p>(*) VISA is a standardized software interface library providing input and output functions to communicate with instruments. A VISA installation on the controller is a prerequisite for remote control over LAN (when using VXI-11 or HiSLIP protocol) and USBTMC interfaces.</p>		

### 9.1.1 USB interface

For remote control over the USB, the computer and the sensor modules must be connected over the USB interface. A USB connection requires that you have installed the VISA library. VISA detects and configures a sensor module automatically when the USB connection is established. Apart from the USBTMC driver (which comes with the installation of the R&S NRP Toolkit), you do not have to install a separate driver.

**USBTMC** is a protocol that is built on top of USB for communication with USB devices. It defines class code information of the sensor module, that identifies its functionality to load the respective device driver. Usually, the USBTMC functions are implemented in VISA libraries provided by various vendors.

A VISA library covers basic I/O functions (open, close, read, write, etc.). It also supports service requests, triggers and other operations over USB and LAN interfaces that were previously implemented only for GPIB devices.

#### USB resource string

The resource string represents an addressing scheme that is used to establish a communication session with the sensor module. It is based on the sensor module address and some instrument- and vendor-specific information.

The syntax of the used USB resource string is:

```
USB::::<product ID>::[::INSTR]
```

Where:

- <vendor ID> is the vendor ID for Rohde & Schwarz (0x0AAD).
- <product ID> is the product ID for the Rohde & Schwarz sensor module.
- <serial number> is the individual serial number at the rear of the sensor module.

**Table 9-2: R&S NRPM3(N) USB product IDs**

Sensor module	USB product ID
R&S NRPM3	0x0195
R&S NRPM3N	0x0196

### Example:

```
USB::0x0AAD::0x0196::100001
```

0x0AAD is the vendor ID for the Rohde & Schwarz sensor module.

0x0196 is the product ID for the particular model (here R&S NRPM3N sensor module).

100001 is the serial number of the sensor module.

## 9.1.2 Ethernet interface

The Ethernet interface of the R&S NRPM3N LAN sensor modules allows you to integrate them in a local area network (LAN).

For remote control via a network, the computer and the sensor module must be connected via the Ethernet interface to a common network with TCP/IP network protocol. The TCP/IP network protocol and the associated network services are preconfigured on the sensor module. Software for device control and the VISA program library must be installed on the computer.

### 9.1.2.1 VISA resource string

The VISA resource string is required to establish a communication session between the controller and the R&S NRPM3N in a LAN. The resource string is a

## Remote control interfaces and protocols

unique identifier, composed of the specific IP address of the sensor module and some network and VISA-specific keywords.

TCPIP::*<IP address or hostname>*[:*<LAN device name>*][:INSTR]

- *TCPIP* designates the network protocol used
- *<IP address or hostname>* is the IP address or host name of the device
- [*[:<LAN device name>*] defines the protocol and the instance number of a sub-instrument:
- [*[:INSTR]*] indicates the sensor module resource class (optional)

The IP address or hostname is used by the programs to identify and control the sensor module. While the hostname is determined by settings in the sensor module, the IP address is assigned by a DHCP server when the sensor module requests one. Alternatively the IP address is determined with a procedure called Zeroconf.

You can also assign a *LAN device name* which defines the protocol characteristics of the connection. See the description of the VISA resource string below for the corresponding interface protocols. The string of the *LAN device name* is emphasized in italics.

### HiSLIP

TCPIP::*<IP address or hostname>*::*hislip0*[:INSTR]

- *hislip0* is the HiSLIP device name, designates that the interface protocol HiSLIP is used (mandatory)

*hislip0* is composed of [*[:HiSLIP device name*[,HiSLIP port]]] and must be assigned.

For details of the HiSLIP protocol, refer to [Chapter 9.1.2.3, "HiSLIP protocol"](#), on page 93.

### VXI-11

TCPIP::*<IP address or hostname>*[:*inst0*][:INSTR]

- *inst0* is the LAN device name, indicating that the VXI-11 protocol is used (optional)

*inst0* currently selects the VXI-11 protocol by default and can be omitted.

For details of the VXI-11 protocol, refer to [Chapter 9.1.2.2, "VXI-11 protocol"](#), on page 93 .

## Socket communication

TCPIP::*<IP address or hostname>*::*port*::*SOCKET*

- *port* determines the used port number
- *SOCKET* indicates the raw network socket resource class

Socket communication requires the specification of the port (commonly referred to as port number) and of "SOCKET" to complete the VISA resource string with the associated protocol used.

The default port for socket communication is port 5025.

For details of the socket communication, refer to [Chapter 9.1.2.4, "Socket communication"](#), on page 94.

### Example:

A sensor module has the IP address *10.111.11.20*; the valid resource string using VXI-11 protocol is:

```
TCPIP::10.111.11.20::INSTR
```

The DNS host name is *nrpm3-100001*; the valid resource string is:

```
TCPIP::nrpm3-100001::hislip0 (HiSLIP)
```

```
TCPIP::nrpm3-100001::inst0 (VXI-11)
```

A raw socket connection can be established using:

```
TCPIP::10.111.11.20::5025::SOCKET
```

```
TCPIP::nrpm3-100001::5025::SOCKET
```

### 9.1.2.2 VXI-11 protocol

The VXI-11 standard is based on the ONC RPC (Open Network Computing Remote Procedure Call) protocol which in turn relies on TCP/IP as the network/transport layer. The TCP/IP network protocol and the associated network services are preconfigured. TCP/IP ensures connection-oriented communication, where the order of the exchanged messages is adhered to and interrupted links are identified. With this protocol, messages cannot be lost.

### 9.1.2.3 HiSLIP protocol

The HiSLIP (high-speed LAN instrument protocol) is the successor protocol for VXI-11 for TCP-based instruments specified by the IVI foundation. The protocol

## Remote control interfaces and protocols

uses two TCP sockets for a single connection - the first for fast data transfer, the second one for non-sequential control commands (e.g. `Device Clear` or `SRQ`).

HiSLIP has the following characteristics:

- High performance as with raw socket network connections
- Compatible IEEE 488.2 support for Message Exchange Protocol, Device Clear, Serial Poll, Remote/Local, Trigger, and Service Request
- Uses a single IANA registered port (4880), which simplifies the configuration of firewalls
- Supports simultaneous access of multiple users by providing versatile locking mechanisms
- Usable for IPv6 or IPv4 networks

 The HiSLIP data is sent to the device using the "fire and forget" method with immediate return. Opposed to VXI-11, where each operation is blocked until a VXI-11 device handshake returns. Thus, a successful return of a VISA operation such as `viWrite()` does not guarantee that the sensor module has finished (or even started) executing the requested command. It just indicates that the command has been delivered to the TCP/IP buffers.

For more information see also the application note at:

<http://www.rohde-schwarz.com/appnote/1MA208>.

#### 9.1.2.4 Socket communication

An alternative way for remote control of the software is to establish a simple TCP/IP connection to the device using the standard network drivers of your operating system. The so-called "socket" on Linux, "winsock" on Windows. The socket communication, also referred to as "raw Ethernet communication", does not necessarily require a VISA installation on the remote controller side.

Socket connections are established on a specially defined port. The socket address is a combination of the IP address or hostname of the sensor module and the number of the port configured for remote control. The sensor modules use port number 5025 for this purpose.

## 9.2 Status reporting system

The status reporting system stores all information on the current operating state of the sensor module, and on errors which have occurred. This information is stored in the status registers and in the error queue. You can query both with the commands of the `STATUS` subsystem.

### 9.2.1 Hierarchy of the status registers

[Fig.9-1](#) shows the hierarchical structure of information in the status registers.

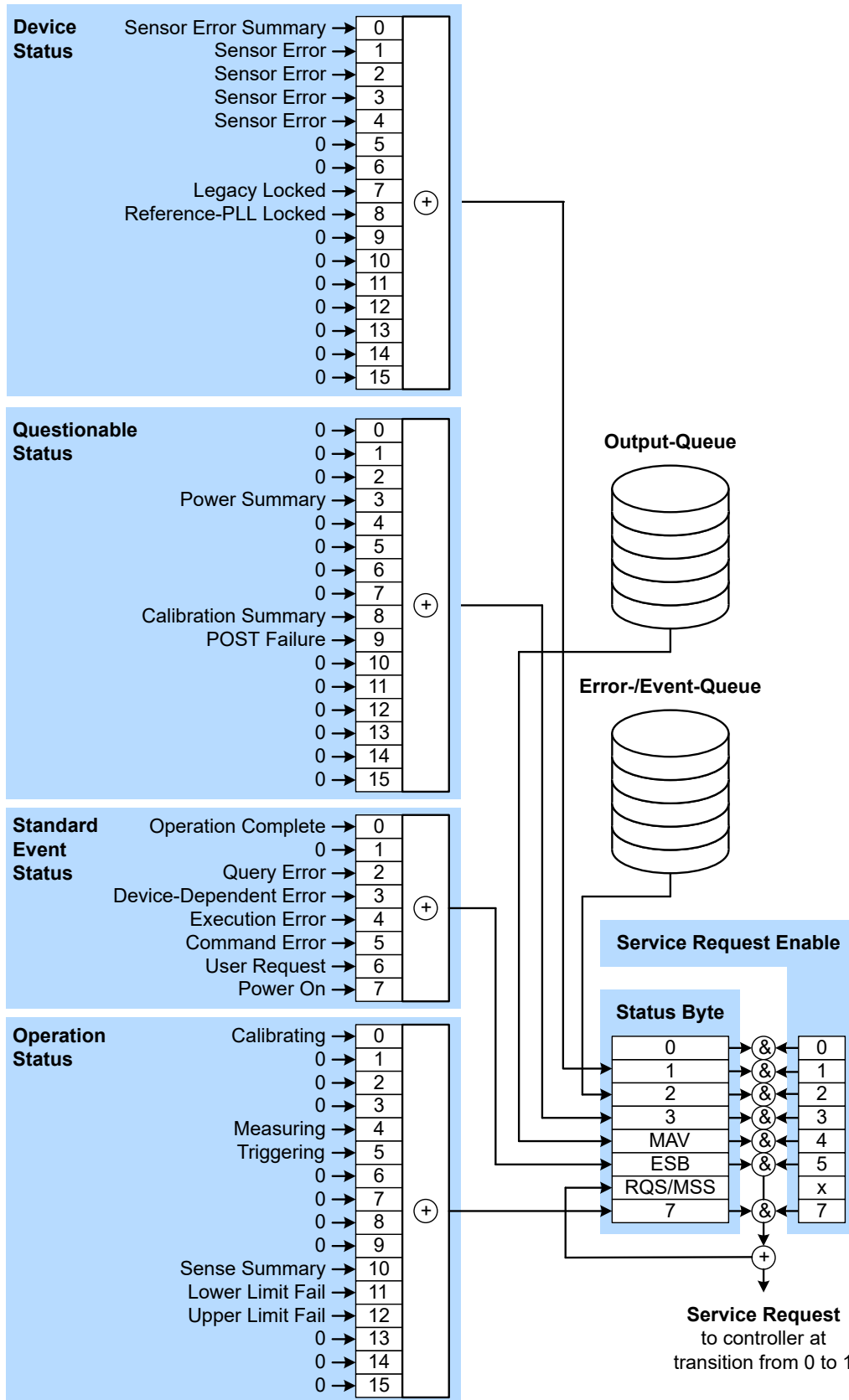

Figure 9-1: Graphical overview of the status registers hierarchy



The highest level is formed by the status byte register (STB) and the associated service request enable (SRE) register.

The STB receives its information from the standard event status register (ESR) and the associated Standard Event Status Enable (ESE) Register, as well as from the SCPI-defined operation status register, and the questionable status register, which contain detailed information on the device, and from the device status register.

## 9.2.2 Structure of an SCPI status register

Each SCPI register consists of five 16-bit registers which have different functions (see Figure 9-2). The individual bits are independent of each other, i.e. each hardware status is assigned a bit number which is the same for all five registers. Bit 15 (the most-significant bit) is set to zero in all registers. This prevents problems some controllers have with the processing of unsigned integers.

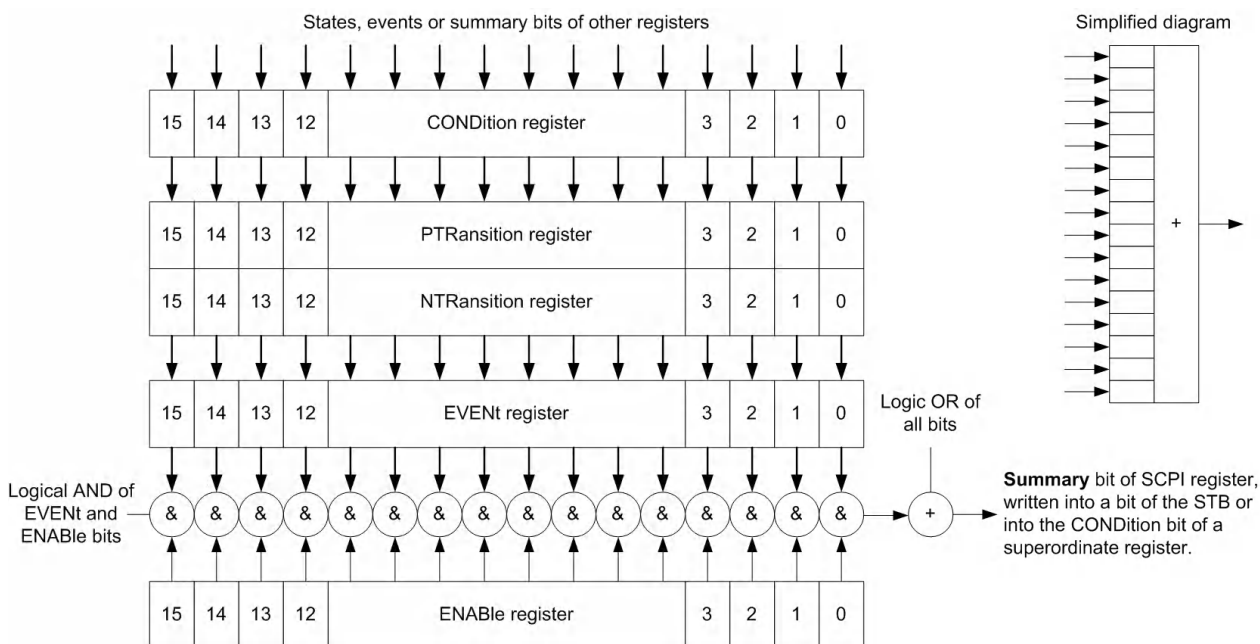

Figure 9-2: Standard SCPI status register

### CONDition status register part

The five parts of an SCPI register have different properties and functions:

The CONDition part is written into directly by the hardware or the sum bit of the next lower register. Its contents reflect the current instrument status. This register

part can only be read, but not written into or cleared. Its contents are not affected by reading.

### **PTRansition / NTRansition status register part**

The two transition register parts define which state transition of the `CONDition` part (none, 0 to 1, 1 to 0 or both) is stored in the `EVENT` part.

The *Positive TRansition* part acts as a transition filter. When a bit of the `CONDition` part is changed from 0 to 1, the associated `PTR` bit decides whether the `EVENT` bit is set to 1.

- `PTR` bit =1: the `EVENT` bit is set.
- `PTR` bit =0: the `EVENT` bit is not set.

This part can be written into and read as required. Its contents are not affected by reading.

The *Negative TRansition* part also acts as a transition filter. When a bit of the `CONDition` part is changed from 1 to 0, the associated `NTR` bit decides whether the `EVENT` bit is set to 1.

- `NTR` bit =1: the `EVENT` bit is set.
- `NTR` bit =0: the `EVENT` bit is not set.

This part can be written into and read as required. Its contents are not affected by reading.

### **EVENT status register part**

The `EVENT` part indicates whether an event has occurred since the last reading, it is the "memory" of the condition part. It only indicates events passed on by the transition filters. It is permanently updated by the instrument.

This part can only be read by the user. Reading the register clears it. This part is often equated with the entire register.

### **ENABLE status register part**

The `ENABLE` part determines whether the associated `EVENT` bit contributes to the sum bit (see below). Each bit of the `EVENT` part is "ANDed" with the associated `ENABLE` bit (symbol '&'). The results of all logical operations of this part are passed on to the sum bit via an "OR" function (symbol '+').

`ENABLE` bit = 0: the associated `EVENT` bit does not contribute to the sum bit.

ENABLE bit = 1: if the associated EVENT bit is "1", the sum bit is set to "1" as well.

This part can be written into and read by the user as required. Its contents are not affected by reading.

### Sum bit

The sum bit is obtained from the EVENT and ENABLE part for each register. The result is then entered into a bit of the CONDITION part of the higher-order register.

The instrument automatically generates the sum bit for each register. Thus an event can lead to a service request throughout all levels of the hierarchy.

## 9.2.3 Status byte (STB) and service request enable register (SRE)

The STB is already defined in IEEE 488.2. It gives a rough overview of the sensor module status, collecting information from the lower-level registers. It is comparable with the CONDITION register of an SCPI defined register and is at the highest level of the SCPI hierarchy. Its special feature is that bit 6 acts as the summary bit of all other bits of the Status Byte Register.

The status byte is read by the query \*STB? or a serial poll. The SRE is associated with the STB. The function of the SRE corresponds to that of the ENABLE register of the SCPI registers. Each bit of the STB is assigned a bit in the SRE. Bit 6 of the SRE is ignored. If a bit is set in the SRE and the associated bit in the STB changes from 0 to 1, a service request (SRQ) is generated on the IEC/IEEE bus, which triggers an interrupt in the controller configured for this purpose, and can be further processed by the controller.

The SRE can be set by the command \*SRE and read by the query \*SRE?.

**Table 9-3: Meaning of bits used in the status byte**

Bit No.	Meaning
0	Not used
1	<p><b>Device status register summary bit</b></p> <p>Depending on the configuration of the sensor modules status register, this bit is set when a sensor module is connected or disconnected or when an error has occurred in a sensor module.</p> <p>See <a href="#">Chapter 9.2.5, "Device status register"</a>, on page 101.</p>

Bit No.	Meaning
2	<p><b>Error queue not empty</b></p> <p>The bit is set if the error queue has an entry. If this bit is enabled by the SRE, each entry of the error queue generates a service request. An error can thus be recognized and specified in detail by querying the error queue. The query yields a conclusive error message. This procedure is recommended since it considerably reduces the problems of IEC/IEEE-bus control.</p>
3	<p><b>Questionable status register summary bit</b></p> <p>This bit is set if an <code>EVENT</code> bit is set in the <code>QUESTionable</code> status register and the associated <code>ENABLE</code> bit is set to 1. A set bit denotes a questionable device status which can be specified in greater detail by querying the <code>QUESTionable</code> Status Register.</p> <p>See <a href="#">Chapter 9.2.6, "Questionable status register"</a>, on page 102.</p>
4	<p><b>MAV bit (Message available)</b></p> <p>This bit is set if a readable message is in the output queue. This bit may be used to automate reading of data from the sensor module into the controller.</p>
5	<p><b>ESB: Standard event status register summary bit</b></p> <p>This bit is set if one of the bits in the standard event status register is set and enabled in the event status enable register. Setting this bit denotes a serious error which can be specified in greater detail by querying the standard event status register.</p> <p>See <a href="#">Chapter 9.2.7, "Standard event status and enable register (ESR, ESE)"</a>, on page 104.</p>
6	<p><b>MSS: Master status summary bit</b></p> <p>This bit is set if the sensor module triggers a service request. This is the case if one of the other bits of this register is set together with its enable bit in the service request enable register (SRE).</p>
7	<p><b>Operation status register summary bit</b></p> <p>This bit is set if an <code>EVENT</code> bit is set in the operation status register and the associated <code>ENABLE</code> bit is set to 1. A set bit denotes that an action is being performed by the sensor module. Information on the type of action can be obtained by querying the operation status register.</p> <p>See <a href="#">Chapter 9.2.8, "Operation status register"</a>, on page 105.</p>

## 9.2.4 IST flag and parallel poll enable register (PPE)

Similar to the SRQ, the IST flag combines the complete status information in a single bit. It can be queried by a parallel poll or by the `*IST?` command.

The Parallel Poll Enable Register (PPE) determines which bits of the STB affect the IST flag. The bits of the STB are ANDed with the corresponding bits of the

PPE; bit 6 is also used - in contrast to the SRE. The IST flag is obtained by ORing all results together.

The PPE can be set by the \*PRE command and read by the \*PRE? query.

## 9.2.5 Device status register

Contains information on the state of the static errors.

Querying the register:

- `STATus:DEVIce:CONDition?`
- `STATus:DEVIce[:EVENT]?`

Querying the static errors:

- `SYSTem:SERRor?`

**Table 9-4: Meaning of bits used in the device status register**

Bit No.	Meaning
<b>0</b>	<b>Sum of SERR bits</b> The sum/combination of SERR bits 1 to 4.
<b>1</b>	<b>SERR measurement not possible</b>
<b>2</b>	<b>SERR erroneous results</b> Static error exists; the measurement result is possibly incorrect.
<b>3</b>	<b>SERR warning</b> A static error exists therefore the Status LED of the sensor module is blinking slowly in red.
<b>4</b>	<b>SERR critical</b> A critical static error exists therefore the Status LED of the sensor module is blinking fast in red.
<b>5 to 6</b>	Not used

Bit No.	Meaning
8	<p><b>Reference PLL locked state</b></p> <p>This bit signals whether the PLL for the clock reference is synchronized. The bit is useful when selecting an external clock source.</p> <p>The following states are possible:</p> <ul style="list-style-type: none"> <li>• Internal clock (<code>[SENSe&lt;Sensor&gt;:]ROSCillator:SOURce INTernal INT</code>): <ul style="list-style-type: none"> <li>– 1 (always)</li> </ul> </li> <li>• External clock (<code>[SENSe&lt;Sensor&gt;:]ROSCillator:SOURce EXTernal</code>): <ul style="list-style-type: none"> <li>– 1 if the sensor module was able to synchronize with external clock</li> <li>– 0 if the sensor module could not synchronize with external clock</li> </ul> </li> </ul>
9 to 15	Not used

## 9.2.6 Questionable status register

Contains information on questionable sensor module states. Such states may occur when the sensor module is not operated in compliance with its specifications.

Querying the register:

- `STATus:QUEStionable:CONDition?`
- `STATus:QUEStionable[:EVENT]?`

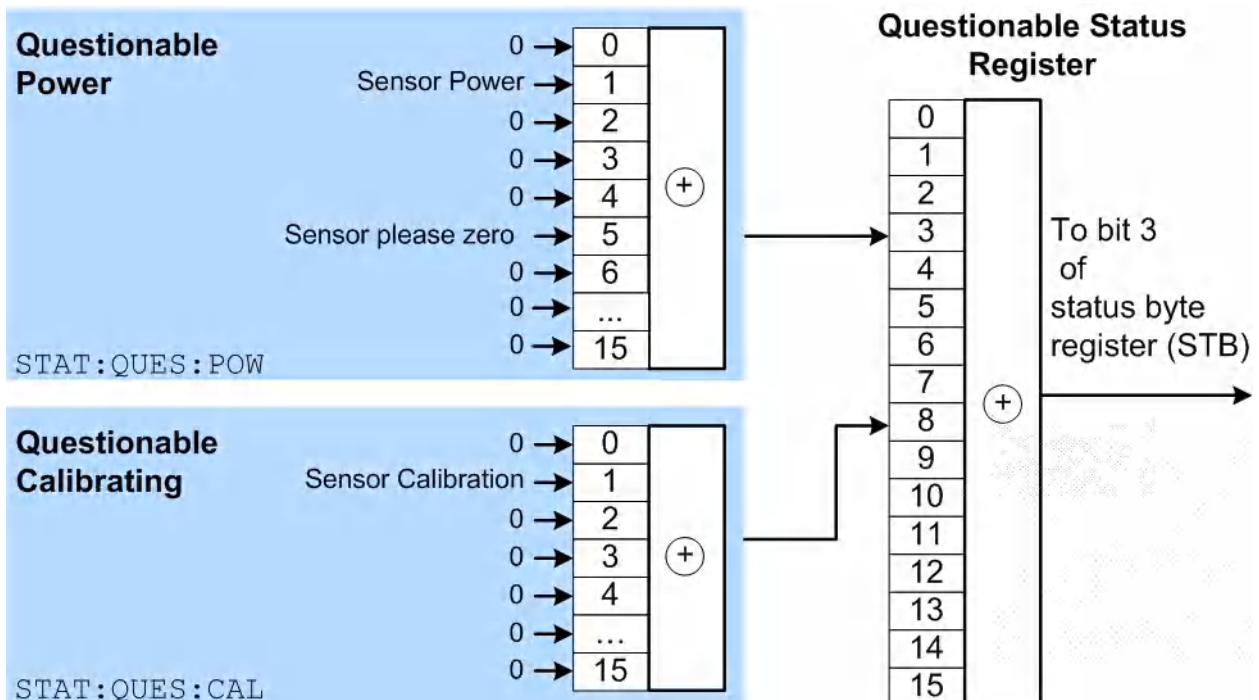

**Table 9-5: Meaning of bits used in the questionable status register**

Bit No.	Meaning
0 to 2	Not used
3	<b>Questionable power status register summary bit</b> Corresponds to the summary bit of the questionable power status register. See <a href="#">Chapter 9.2.6.1, "Questionable power status register"</a> , on page 103.
4 to 7	Not used
8	<b>Questionable calibration status register summary bit</b> Corresponds to the summary bit of the questionable calibration status register. See <a href="#">Chapter 9.2.6.2, "Questionable calibration status register"</a> , on page 104.
9	<b>POST failure</b> The built-in test of the R&S NRPM carried out automatically upon power-up has generated an error.
10 to 15	Not used

### 9.2.6.1 Questionable power status register

The `CONDition` register contains information whether the measured power values are questionable.

Querying the register:

- `STATus:QUESTionable:POWER:CONDition?`
- `STATus:QUESTionable:POWER[:SUMMARY][:EVENT]?`

**Table 9-6: Meaning of bits used in the questionable power status register**

Bit No.	Meaning
0	Not used
1	<b>sensor module power</b> The measurement data of the sensor module is corrupt.
2 to 4	Not used
5	<b>sensor module please zero</b> The zero correction for the sensor module is no longer correct and should be repeated.
6 to 15	Not used

### 9.2.6.2 Questionable calibration status register

The `EVENT` register and the `CONDition` register contain information whether the zero offset of a sensor module is still valid.

Querying the register:

- `STATUS:QUESTIONABLE:CALIBRATION:CONDition?`
- `STATUS:QUESTIONABLE:CALIBRATION[:SUMMARY][:EVENT]?`

**Table 9-7: Meaning of bits used in the questionable calibration status register**

Bit No.	Meaning
0	Not used
1	<b>sensor module calibration</b> Zeroing of the sensor module was not successful.
2 to 15	Not used

### 9.2.7 Standard event status and enable register (ESR, ESE)

The `ESR` is already defined in the IEEE 488.2 standard. It is comparable to the `EVENT` register of an SCPI register. The standard event status register can be read out by the query `*ESR`.

The `ESE` forms the associated `ENABLE` register. It can be set and read out with the command/query `*ESE`.

**Table 9-8: Meaning of bits used in the standard event status register**

Bit No.	Meaning
0	<b>Operation complete</b> When the <code>*OPC</code> command is received, this bit is set if all previous commands have been executed.
1	Not used
2	<b>Query error</b> This bit is set in either of the two following cases: the controller wants to read data from the sensor module but has not sent a query, or it sends new commands to the sensor module before it retrieves existing requested data. A frequent cause is a faulty query which cannot be executed.
3	<b>Device-dependent error</b> This bit is set if a sensor module dependent error occurs. An error message with a number between -300 and -399 or a positive error number denoting the error in greater detail is entered in the error queue.



Bit No.	Meaning
4	<b>Execution error</b> This bit is set if the syntax of a received command is correct but the command cannot be executed due to various marginal conditions. An error message with a number between -200 and -300 denoting the error in greater detail is entered in the error queue.
5	<b>Command error</b> This bit is set if an undefined command or a command with incorrect syntax is received. An error message with a number between -100 and -200 denoting the error in greater detail is entered in the error queue.
6	<b>User request</b> This bit is set when the sensor module is switched over to manual control.
7	<b>Power on</b> This bit is set when the sensor module is switched on.

## 9.2.8 Operation status register

The `CONDition` register contains information on the operations currently being performed by the sensor module, while the `EVENT` register contains information on the operations performed by the since the last readout of the register.

Querying the register:

- `STATUS:OPERation:CONDition?`
- `STATUS:OPERation[:EVENT]?`

**Table 9-9: Meaning of bits used in the operation status register**

Bit No.	Meaning
0	<b>Calibrating status register summary bit</b> This bit is set if the sensor module is being calibrated. See <a href="#">Chapter 9.2.8.1, "Operation calibrating status register"</a> , on page 108.
1 to 3	Not used
4	<b>Measuring status register summary bit</b> This bit is set if the sensor module is performing a measurement. See <a href="#">Chapter 9.2.8.2, "Operation measuring status register"</a> , on page 108.
5	<b>Trigger status register summary bit</b> This bit is set if the sensor module is in the waiting for trigger state, i.e. waiting for a trigger event. See <a href="#">Chapter 9.2.8.3, "Operation trigger status register"</a> , on page 109.
6	Not used

Bit No.	Meaning
7 to 9	Not used
10	<b>Sense status register summary bit</b> This bit is set if a sensor module is initialized. See <a href="#">Chapter 9.2.8.4, "Operation sense status register"</a> , on page 109.
11	<b>Lower limit fail status register</b> This bit is set if a displayed value has dropped below a lower limit value. See <a href="#">Chapter 9.2.8.5, "Operation lower limit fail status register"</a> , on page 110.
12	<b>Upper limit fail status register</b> This bit is set if a displayed value has exceeded an upper limit value. See <a href="#">Chapter 9.2.8.6, "Operation upper limit fail status register"</a> , on page 110.
13 to 14	Not used
15	Bit 15 will never be used.

Status reporting system

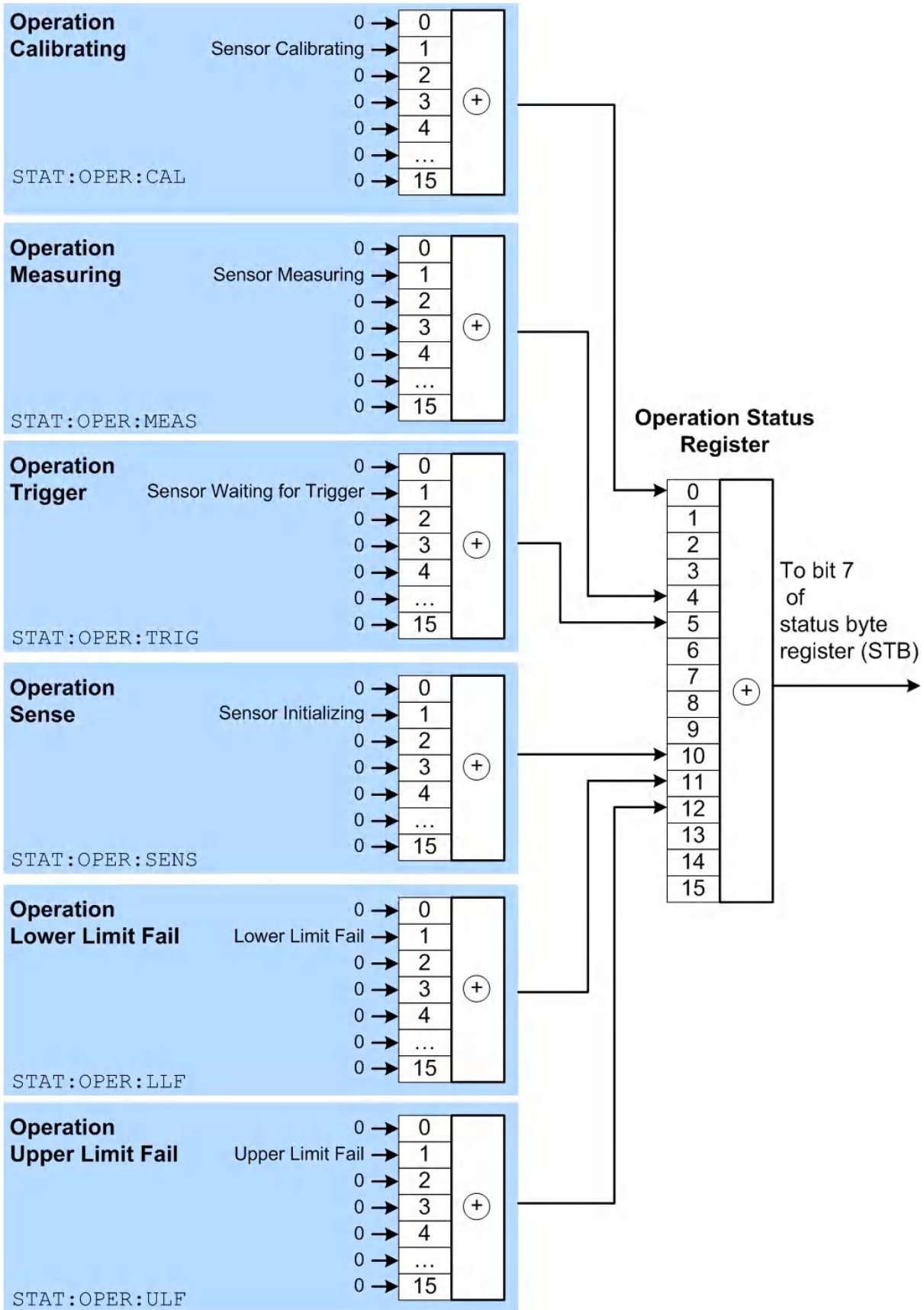

### 9.2.8.1 Operation calibrating status register

The `CONDition` register contains information about whether a sensor module is currently being calibrated and, depending on the configuration of the transition register. The `EVENT` register indicates whether a calibration was started or completed since the last readout of this register.

Querying the register:

- `STATUS:OPERation:CALibrating:CONDition?`
- `STATUS:OPERation:CALibrating[:SUMMARY][:EVENT]?`

**Table 9-10: Meaning of bits used in the operation calibrating status register**

Bit No.	Meaning
0	Not used
1	<b>sensor module calibrating</b> The sensor module is being calibrated
5 to 15	Not used

### 9.2.8.2 Operation measuring status register

The `CONDition` register contains information about whether a measurement is being performed by a sensor module and, depending on the configuration of the transition register. The `EVENT` register indicates whether a measurement was started or completed since the last readout of this register.

Querying the register:

- `STATUS:OPERation:MEASuring:CONDition?`
- `STATUS:OPERation:MEASuring[:SUMMARY][:EVENT]?`

**Table 9-11: Meaning of bits used in the operation measuring status register**

Bit No.	Meaning
0	Not used
1	<b>sensor module measuring</b> The sensor module is performing a measurement.
5 to 15	Not used

### 9.2.8.3 Operation trigger status register

The `CONDition` register contains information about whether a sensor module is currently in the waiting for trigger state, i.e. expecting a trigger event and, depending on the configuration of the transition register. The `EVENTt` register indicates whether the waiting for trigger state was entered or quit by a sensor module since the last readout of the register.

Querying the register:

- `STATus:OPERation:TRIGger:CONDition?`
- `STATus:OPERation:TRIGger[:SUMMARY][:EVENTt]?`

**Table 9-12: Meaning of bits used in the operation trigger status register**

Bit No.	Meaning
0	Not used
1	<b>sensor module waiting for trigger</b> The sensor module is in the waiting for trigger state and is waiting for a trigger event. When the trigger event occurs, the sensor module changes into the measuring state.
5 to 15	Not used

### 9.2.8.4 Operation sense status register

The `CONDition` register contains information about whether a sensor module is currently being initialized and, depending on the configuration of the transition register. The `EVENTt` register indicates whether a sensor module initialization was started or completed since the last readout of this register.

This status is assumed by a sensor module if one of the following conditions is met:

- The supply voltage is switched on (power up)
- The sensor module was just connected
- A reset was performed using:
  - `*RST`
  - `SYSTem:PRESet`

Querying the register:

- `STATus:OPERation:SENSe:CONDition?`
- `STATus:OPERation:SENSe[:SUMMARY][:EVENTt]?`

**Table 9-13: Meaning of bits used in the operation sense status register**

Bit No.	Meaning
0	Not used
1	<b>sensor module initializing</b> The sensor module is being initialized.
5 to 15	Not used

### 9.2.8.5 Operation lower limit fail status register

The `CONDition` register contains information about whether a displayed value is currently below a configured lower limit. The `EVENT` register indicates whether a measured value dropped below a limit value since the last readout of the Operation Lower Limit Fail Status Register. Details of the behavior are defined by the transition register.

Querying the register:

- `STATUS:OPERation:LLFail:CONDition?`
- `STATUS:OPERation:LLFail[:SUMMARY][:EVENT]?`

**Table 9-14: Meaning of bits used in the operation lower limit fail status register**

Bit No.	Meaning
0	Not used
1	<b>Lower limit fail</b> The measured value drops below the lower limit value.
5 to 15	Not used

### 9.2.8.6 Operation upper limit fail status register

The `CONDition` register contains information about whether a displayed value is currently above a configured upper limit. The `EVENT` register indicates whether a limit value was exceeded since the last readout of the Operation Upper Limit Fail Status Register.

Querying the register:

- `STATUS:OPERation:ULFail:CONDition?`
- `STATUS:OPERation:ULFail[:SUMMARY][:EVENT]?`

*Table 9-15: Meaning of bits used in the operation lower limit fail status register*

Bit No.	Meaning
0	Not used
1	<b>Upper limit fail</b> The measured value exceeds the upper limit value.
5 to 15	Not used

# 10 Remote control commands

In the following sections, all commands implemented in the sensor are listed according to the command system and then described in detail. Mostly, the notation used complies with SCPI specifications.

## 10.1 Conventions used in SCPI command descriptions

The following conventions are used in the remote command descriptions:

- **Command usage**  
If not specified otherwise, commands can be used both for setting and for querying parameters.  
If a command can be used for setting or querying only, or if it initiates an event, the usage is stated explicitly.
- **Parameter usage**  
If not specified otherwise, a parameter can be used to set a value and it is the result of a query.  
Parameters required only for setting are indicated as **Setting parameters**.  
Parameters required only to refine a query are indicated as **Query parameters**.  
Parameters that are only returned as the result of a query are indicated as **Return values**.
- **Conformity**  
Commands that are taken from the SCPI standard are indicated as **SCPI confirmed**. All commands used by the R&S NRPM follow the SCPI syntax rules.
- **Asynchronous commands**  
A command which does not automatically finish executing before the next command starts executing (overlapping command) is indicated as an **Asynchronous command**.
- **Reset values (\*RST)**  
Default parameter values that are used directly after resetting the instrument (\*RST command) are indicated as **\*RST** values, if available.
- **Default unit**  
The default unit is used for numeric values if no other unit is provided with the parameter.



**Table 10-1: Units**

Basic unit	Also noted as
Hz	Frequency
s	Seconds
W	Watts
degrees	Angle
PCT	Percent
dB	DB
dBm	DBM
dBuV	DBUV

## 10.2 Notations

For a detailed description of SCPI notations, see [Remote control via SCPI](#).

### Numeric suffixes <n>

If a command can be applied to multiple instances of an object, e.g. specific sensor modules, the required instances can be specified by a suffix added to the command. Numeric suffixes are indicated by angular brackets (<1...4>, <n>, <l>) and are replaced by a single value in the command. Entries without a suffix are interpreted as having the suffix 1.

### Optional keywords [ ]

Some command systems permit certain keywords to be inserted into the header or omitted. These keywords are marked by square brackets in the description. The instrument must recognize the long command to comply with the SCPI standard. Some commands are considerably shortened by these optional mnemonics.

Therefore, not only is there a short and a long form for the commands (distinguished here by uppercase and lowercase letters) but also a short form which is created by omitting optional keywords.

**Example:**

Command [SENSE<Sensor>:] [POWER:] [AVG:] SMOothing:STATe 1 can be written as:

```
SENSE1:POWER:AVG:SMOothing:STATe 1
```

```
SENS:POW:AVG:SMO:STAT 1
```

```
SENSE:POWER:SMOothing:STATe 1
```

```
SENSE:SMOothing:STATe 1
```

```
SMOothing:STATe 1
```

```
SMO:STAT 1
```

**Parameters**

Parameters must be separated from the header by a "white space". If several parameters are specified in a command, they are separated by a comma (,).

**Example:**

Definition: [SENSE<Sensor>:] AVERage:COUNT:AUtO:NSRatio <nsr>

Command: AVER:COUN:AUtO:NSR 0.01

**Special characters | and { }**

	<p>A vertical bar in parameter definitions indicates alternative possibilities in the sense of "or". The effect of the command differs, depending on which parameter is used.</p> <p><b>Example:</b></p> <p>Definition: INITiate:CONTinuous ON   OFF</p> <p>Command INITiate:CONTinuous ON starts the measurements</p> <p>Command INITiate:CONTinuous OFF stops the measurements</p>
{ }	<p>Parameters in braces may be included in the command once, several times or not at all.</p>

## 10.3 Common commands

The common commands are taken from the IEEE 488.2 (IEC 625–2) standard. The headers of these commands consist of an asterisk \* followed by three letters.

## Remote Commands:

*CLS.....	115
*ESE.....	115
*ESR?.....	116
*IDN?.....	116
*IST?.....	116
*OPC.....	116
*OPT?.....	117
*PRE.....	117
*RCL.....	117
*RST.....	118
*SAV.....	118
*SRE.....	118
*STB?.....	118
*TRG.....	119
*TST?.....	119
*WAI.....	119

---

**\*CLS**

## CLear Status

Resets the:

- Status byte (STB)
- Standard event register (ESR)
- EVENT part of the QUESTionable and the OPERation register
- Error/event queue

The command does not alter the ENABLE and TRANSition parts of the registers.

**Usage:**                   Event

---

**\*ESE <register>**

## Event Status Enable

Sets the event status enable register to the specified value. The query returns the contents of the event status enable register in decimal form.

**Parameters:**

<register>                      Range:        0 to 255  
                                      \*RST:        0

---

**\*ESR?**

Event Status Read query

Returns the contents of the event status register in decimal form (0 to 255) and subsequently sets the register to zero.

**Usage:**                              Query only

---

**\*IDN?**

IDeNtification query

Returns a string with information on the sensor's identity (device identification code). In addition, the version number of the installed firmware is indicated.

**Usage:**                              Query only

---

**\*IST?**

Individual SStatus query

Returns the current value of the IST flag in decimal form. The IST flag is the status bit which is sent during a parallel poll.

**Usage:**                              Query only

---

**\*OPC**

OPeration Complete

Sets bit 0 in the event status register when all preceding commands have been executed. This bit can be used to initiate a service request. \*OPC must be sent at the end of a program message.

The query form returns a "1" when all previous commands have been processed. It is important that the read timeout is set sufficiently long.

Since `*OPC?` waits until all previous commands are executed, "1" is returned in all cases.

`*OPC?` basically functions like the `*WAI` command, but `*WAI` does not return a response.

`*OPC?` is preferred to `*WAI` because with `*OPC?`, the execution of commands can be queried from a controller program before new commands are sent. This prevents overflow of the input queue when too many commands are sent that cannot be executed.

Unlike `*WAI`, `*OPC?` must be sent at the end of a program message.

### **\*OPT?**

OPTion identification query

Returns a comma-separated list of installed options.

**Usage:**                      Query only

### **\*PRE <register>**

Parallel poll Register Enable

Sets the parallel poll enable register to the specified value or queries the current value.

#### **Parameters:**

<code>&lt;register&gt;</code>	Range:	0 to 255
	<code>*RST:</code>	0

### **\*RCL <number>**

ReCaLI

Calls the device state which has been stored with the `*SAV` command under the specified number.

#### **Setting parameters:**

<code>&lt;number&gt;</code>	Range:	0 to 9
	<code>*RST:</code>	0

**Usage:**                      Setting only

**\*RST**

Reset

Sets the instrument to a defined default status. The default settings are indicated in the description of commands.

The command corresponds to the `SYSTem:PRESet` command.

**Usage:** Event

---

**\*SAV <number>**

SAVe

Stores the current device state under the specified number. The storage numbers 0 to 9 are available.

**Setting parameters:**

<number>	Range:	0 to 9
	*RST:	0

**Usage:** Setting only

---

**\*SRE <register>**

Service Request Enable

Sets the service request enable register to the specified value. This command determines under which conditions a service request is triggered.

**Parameters:**

<register>	Range:	0 to 255
	*RST:	0

---

**\*STB?**

STatus Byte query

Returns the contents of the status byte in decimal form.

**Usage:** Query only

---

**\*TRG**

TRiGger

Triggers a measurement. This command is only valid if the power sensor is in the waiting for trigger state and the trigger source is set to `BUS`

See `TRIGger:SOURce > BUS` `BUS`.

**Usage:** Event

---

**\*TST?**

Selftest query

Triggers a self test of the instrument and outputs an error code in decimal form. 0 indicates that no errors have occurred.

**Example:**

```
*TST?  
Query  
0  
Response: Passed  
*TST?  
Query  
1  
Response: Failed
```

**Usage:** Query only

---

**\*WAI**

WAI to continue

Prevents the execution of the subsequent commands until all preceding commands have been executed and all signals have settled.

**Usage:** Event

---

## 10.4 Configuring the general functions

### 10.4.1 Configuring the system

The `SYSTem` subsystem contains a series of commands for general functions that do not directly affect the measurement.

Remote commands:

<code>SYSTem:COMMunicate:NETWork:IPADdress</code> .....	121
<code>SYSTem:COMMunicate:NETWork:IPADdress:GATeway</code> .....	121
<code>SYSTem:COMMunicate:NETWork:IPADdress:INFO?</code> .....	122
<code>SYSTem:COMMunicate:NETWork:IPADdress:MODE</code> .....	122
<code>SYSTem:COMMunicate:NETWork:IPADdress:SUBNet:MASK</code> .....	122
<code>SYSTem:COMMunicate:NETWork:RESet</code> .....	123
<code>SYSTem:COMMunicate:NETWork:REStart</code> .....	123
<code>SYSTem:COMMunicate:NETWork:STATus?</code> .....	123
<code>SYSTem:COMMunicate:NETWork[:COMMOn]:DOMain</code> .....	124
<code>SYSTem:COMMunicate:NETWork[:COMMOn]:HOSTname</code> .....	124
<code>SYSTem:DFPRint&lt;Channel&gt;?</code> .....	124
<code>SYSTem:ERRor:ALL?</code> .....	124
<code>SYSTem:ERRor:CODE:ALL?</code> .....	125
<code>SYSTem:ERRor:CODE[:NEXT]?</code> .....	125
<code>SYSTem:ERRor:COUNT?</code> .....	125
<code>SYSTem:ERRor[:NEXT]?</code> .....	126
<code>SYSTem:FWUPdate</code> .....	126
<code>SYSTem:FWUPdate:STATus?</code> .....	127
<code>SYSTem:HELP:HEADers?</code> .....	128
<code>SYSTem:HELP:SYNTax:ALL?</code> .....	128
<code>SYSTem:HELP:SYNTax?</code> .....	128
<code>SYSTem:INFO?</code> .....	128
<code>SYSTem:INITialize</code> .....	129
<code>SYSTem:LANGUage</code> .....	129
<code>SYSTem:LED:CHANnel&lt;Channel&gt;:COLor</code> .....	130
<code>SYSTem:LED:COLor</code> .....	130
<code>SYSTem:LED:MODE</code> .....	131
<code>SYSTem:MINPower?</code> .....	131
<code>SYSTem:PARAmeters?</code> .....	131
<code>SYSTem:PARAmeters:DELTA?</code> .....	131



## Configuring the general functions

SYSTem:PRESet.....	131
SYSTem:REBoot.....	132
SYSTem:REStart.....	132
SYSTem:SERRor:LIST:ALL?.....	132
SYSTem:SERRor:LIST[:NEXT]?.....	132
SYSTem:SERRor?.....	133
SYSTem:TLEVels?.....	133
SYSTem:TRANsaction:BEgin.....	133
SYSTem:TRANsaction:END.....	133
SYSTem:VERSIon?.....	133
SYSTem[:SENSor]:NAME.....	134

**SYSTem:COMMunicate:NETWork:IPADdress <ipaddress>**

R&S NRPM3N LAN sensor modules only

For `SYSTem:COMMunicate:NETWork:IPADdress:MODE STATic`, you can set the address manually.

Sets the IP address.

**Parameters:**

<ipaddress>                      Range:        0.0.0.0. to ff.ff.ff.ff

**Example:**

```
SYSTem:COMMunicate:NETWork:IPADdress
"10.113.0.104"
```

**Manual operation:**    See "[IP Address](#)" on page 80

**SYSTem:COMMunicate:NETWork:IPADdress:GATeway <gateway>**

R&S NRPM3N LAN sensor modules only

Sets the IP address of the default gateway.

For `SYSTem:COMMunicate:NETWork:IPADdress:MODE STATic`, you can set the gateway manually.

**Parameters:**

<gateway>

**Example:**

```
SYSTem:COMMunicate:NETWork:IPADdress:
GATeway '192.168.10.254'
Sets 192.168.10.254 as IP address of the default gateway.
```

**Manual operation:** See ["Gateway"](#) on page 80

---

### **SYSTem:COMMunicate:NETWork:IPADdress:INFO?**

R&S NRPM3N LAN sensor modules only

Queries the network status information.

**Example:** `SYSTem:COMMunicate:NETWork:IPADdress:INFO?`

**Usage:** Query only

---

### **SYSTem:COMMunicate:NETWork:IPADdress:MODE <mode>**

R&S NRPM3N LAN sensor modules only

Sets whether the IP address is assigned automatically or manually.

**Parameters:**

<mode> AUTO | STATic

**AUTO**

Assigns the IP address automatically, provided the network supports DHCP.

**STATic**

Enables you to assign the IP address manually.

\*RST: AUTO

**Example:** `SYSTem:COMMunicate:NETWork:IPADdress:MODE  
AUTO`

The IP address is assigned automatically.

**Manual operation:** See ["DHCP"](#) on page 81

---

### **SYSTem:COMMunicate:NETWork:IPADdress:SUBNet:MASK <netmask>**

R&S NRPM3N LAN sensor modules only

Sets the subnet mask.

For `SYSTem:COMMunicate:NETWork:IPADdress:MODE STATic`, you can set the subnet mask manually.

**Parameters:**

&lt;netmask&gt;

**Example:**

```
SYSTem:COMMunicate:NETWork:IPAdDress:  
SUBNet:MASK '255.255.255.0'  
Sets 255.255.255.0 as subnet mask.
```

**Manual operation:** See "[Subnet Mask](#)" on page 80

---

**SYSTem:COMMunicate:NETWork:RESet**

R&amp;S NRPM3N LAN sensor modules only

Resets the LAN network settings to the default values.

**Example:**

```
SYSTem:COMMunicate:NETWork:RESet
```

**Usage:**

Event

---

**SYSTem:COMMunicate:NETWork:REStArt**

R&amp;S NRPM3N LAN sensor modules only

Restarts the network.

**Example:**

```
SYSTem:COMMunicate:NETWork:REStArt  
Terminates the network connection and sets it up again
```

**Usage:**

Event

---

**SYSTem:COMMunicate:NETWork:STATus?**

R&amp;S NRPM3N LAN sensor modules only

Queries the network configuration state.

**Return values:**

&lt;State&gt; 0 | 1 | OFF | ON

**Example:**

```
SYSTem:COMMunicate:NETWork:STATus?  
Response: 1
```

**Usage:**

Query only

**SYSTem:COMMunicate:NETWork[:COMMOn]:DOMain** <domain>

R&S NRPM3N LAN sensor modules only

Determines the primary suffix of the network domain.

**Parameters:**

<domain>

**Example:**

```
SYSTem:COMMunicate:NETWork:COMMOn:DOMain
"abcd.net"
```

---

**SYSTem:COMMunicate:NETWork[:COMMOn]:HOSTname** <hostname>

R&S NRPM3N LAN sensor modules only

Sets an individual hostname for the sensor module.

**Note:** To avoid problems with the network connection, we recommend that you do not change the hostname. If you change the hostname, be sure to use a unique name.

**Parameters:**

<hostname>

**Example:**

```
SYSTem:COMMunicate:NETWork:COMMOn:HOSTname?
Response: 'nrpm3n-sensormodule2'
```

---

**SYSTem:DFPRint<Channel>?**

Reads the footprint file of the sensor module.

**Suffix:**

<Channel>

1...4

Measurement channel if more than one channels are available.

**Usage:**

Query only

---

**SYSTem:ERRor:ALL?**

Queries all unread entries in the error/event queue and removes them from the queue. The response is a comma-separated list of error numbers and a short description of the error in the first in first out order.

## Configuring the general functions

Positive error numbers are instrument-dependent. Negative error numbers are reserved by the SCPI standard.

**Example:**                `SYSTem:ERRor:ALL?`  
                              Response: 0, "No Error"

**Usage:**                Query only

---

**SYSTem:ERRor:CODE:ALL?**

Queries all unread entries in the error/event queue and removes them from the queue. Only the error numbers are returned and not the entire error text.

**Example:**                `SYSTem:ERRor:CODE:ALL?`  
                              Response: 0  
                              No errors occurred since the last read out of the error queue.

**Usage:**                Query only

---

**SYSTem:ERRor:CODE[:NEXT]?**

Queries the oldest entry in the error queue and then deletes it. The query returns only the error number, not the entire error text.

**Example:**                `SYSTem:ERRor:CODE?`  
                              Response: 0  
                              No errors have occurred since the error queue was last read out.

**Usage:**                Query only

---

**SYSTem:ERRor:COUNT?**

Queries the number of entries in the error queue.

**Example:**                `SYSTem:ERRor:COUNT?`  
                              Response: 1  
                              One error occurred since the last read out of the error queue.

**Usage:**                Query only

---

---

**SYSTem:ERRor[:NEXT]?**

Queries the error/event queue for the oldest item and removes it from the queue. The query returns an error number and a short description of the error.

Positive error numbers are instrument-dependent. Negative error numbers are reserved by the SCPI standard.

**Example:**                   SYSTem:ERRor?  
Queries the oldest entry in the error queue.  
Response: 0, "no error"  
No errors occurred since the last read out of the error queue.

**Usage:**                    Query only

---

**SYSTem:FWUPdate <fwudata>**

Loads new operating firmware into the device. Rohde & Schwarz provides new firmware in files with the extension \*.rsu.

Usually, you find the \*.rsu file at the Rohde & Schwarz web site. Otherwise, consult the customer support or the product marketing.

In addition, Rohde & Schwarz provides dedicated programs for loading new firmware into a R&S NRPM sensor module (e.g. PureFW).

If you want to integrate a firmware update function in your own application, use the SYSTem:FWUPdate command. The parameter of this command is a "Definite Length Arbitrary Block Data", containing the direct copy of the binary \*.rsu file.

A "Definite Length Datablock" has a pre-defined format. It consists of:

- A '#' sign.
- A single digit indicating the length of the number which represents the size of the binary file
- The binary data.
- An appended delimiter (LF, 0x0a).

**Example:**

If you want to update the firmware of the R&S NRPM, you first need an update file, e.g. nrpm3\_FW\_15.02.12.01.rsu.

## Configuring the general functions

Lets assume that this file has a size of 10242884 bytes. To send the file to the sensor module for updating the firmware to the new one, your application must assemble a memory block. The memory block consists of the command, the "Definite Length Block" header, the contents of the \*.rsu file and a trailing delimiter (0x0a = linefeed).

First, have a look at the size of the binary data; it is 10242884 in this case. This number has eight digits. Now you have all the information to assemble everything:

- The SYST:FWUP command
- A blank as a separator.
- The '#' sign.
- The '8' for the length of the file size.
- The '10242884' specifying the size of the file.
- ..... (the contents of the \*.rsu file).....
- 0x0a as a delimiter.

In this example, you would write exactly 10242905 bytes to the sensor module (for example via a 'viWrite()' function).

The result sums up from the values of the above list to:

$$9 + 1 + 1 + 1 + 8 + 10242884 + 1 = 10242905$$

In a (pseudo) string notation, it is:

```
SYST:FWUP #810242884.....(file content)..... <LF>
```

Where <LF> is a single 0x0a character and .....(file content)..... is the direct byte-by-byte contents of the \*.rsu file.

**Setting parameters:**

<fwudata>                      <block\_data>

**Usage:**                      Setting only

**Manual operation:**      See "[Update](#)" on page 81

**SYSTem:FWUPdate:STATus?**

While a firmware update is in progress, the LED of the sensors flashes in bright white color. When the firmware update is completed, you can read the result of the update with the SYST:FWUP:STAT? command.

The result of the query is a readable string.

**Example:**                `SYSTem:FWUPdate:STATus?`  
                              Response: "Success"

**Usage:**                 Query only

**Manual operation:**    See ["Update"](#) on page 81

---

### **SYSTem:HELP:HEADers? [<Item>]**

Returns a list of all SCPI commands supported by the sensor.

**Query parameters:**

<Item>                    <block\_data>

**Usage:**                 Query only

---

### **SYSTem:HELP:SYNTax:ALL?**

Returns a block data with all SCPIs and the relevant parameter infos for each SCPI.

**Usage:**                 Query only

---

### **SYSTem:HELP:SYNTax? [<Item>]**

Returns the relevant parameter information for the specified SCPI.

**Query parameters:**

<Item>

**Example:**                `SYST:HELP:SYNT? 'sens:aver:coun'`

**Usage:**                 Query only

---

### **SYSTem:INFO? [<item>]**

Returns information about the system.

`SYSTem:INFO?<string_value>` is used to query a specific information item. Without <string\_value>, the command returns all available information in a list string, separated by commas.



## Configuring the general functions

<string\_value> can query the information to the following system parameters:

- Manufacturer
- Type
- Stock Number
- Serial
- SW Build
- Sensor Name
- Technology
- Function
- System MinPower
- System MaxPower
- System MinFreq
- System MaxFreq
- Resolution
- Cal. Misc.
- Cal. Abs.
- Cal. Temp.
- Cal. Lin.
- System Cal. Due Date
- Antenna 1 Type
- Antenna 1 Stock number
- Antenna 1 Serial
- Antenna 1 Cal. Due Date
- Antenna 1 Property
- Antenna 2 Type
- Antenna 2 Stock number
- Antenna 2 Serial
- Antenna 2 Cal. Due Date
- Antenna 2 Property
- Antenna 3 Type
- Antenna 3 Stock number
- Antenna 3 Serial
- Antenna 3 Cal. Due Date
- Antenna 3 Property
- System Uptime

If no antenna module is connected, the command returns "not present" for all parameters of the corresponding antenna input.

**Query parameters:**

<item>

**Usage:** Query only

**SYSTem:INITialize**

Sets the sensor to the standard state, i.e. the default settings for all test parameters are loaded in the same way as with \*RST. The sensor then returns a complete list of all supported commands and parameters. With the command, the remote-control software can automatically adapt to the features of different types of sensors with different functionality.

**Usage:** Event

**SYSTem:LANGuage** <language>

Selects an emulation of a different command set.

**Parameters:**

<language> SCPI  
\*RST: SCPI

**SYSTem:LED:CHANnel<Channel>:COLor <color>**

Sets the color of the antenna module LED.

The suffix <channel> selects the corresponding antenna module, and the suffix <color> selects LED on/off.

**Suffix:**

<Channel>                    1...3

**Parameters:**

<color>                    **0**  
                                   The LED is off.

**> 0**  
                                   The LED shines blue.

                                  Range:        0 to 255  
                                   \*RST:        0

**SYSTem:LED:COLor <color>**

Sets the color of the sensor module status LED, if the LED operating mode [SYSTem:LED:MODE USER](#)) is selected.

**Parameters:**

<color>                    Range:        0 to 0x0FFFFFFF  
                                   \*RST:        0xA0A0A0

**Example:**

```
SYSTem:LED:MODE USER
Selects "User" mode for the system status LED.
```

```
SYSTem:LED:COLor #HA000A0
Sets the LED color to magenta.
```

```
SYSTem:LED:COLor #H00C000
Sets the LED color to green.
```

```
SYSTem:LED:MODE SENSOor
Sets the system status LED operating mode back to the
sensor internal settings.
```

**SYSTem:LED:MODE** <mode>

Selects whether the color of the system status LED is controlled by the firmware of the sensor internally or by the user settings.

For more information, see [SYSTem:LED:COLOr](#).

**Parameters:**

<mode>                   USER | SENSor  
\*RST:                   SENSor

---

**SYSTem:MINPower?**

Yields the lower power measurement limit.

The lower measurement limit refers to the sensor or to the combination of a sensor and the components connected ahead of it. This query can be used to determine a useful resolution for the result display near the lower measurement limit.

**Usage:**                   Query only

---

**SYSTem:PARAmeters?**

Lists all commands with default values, limits and ranges.

**Usage:**                   Query only

---

**SYSTem:PARAmeters:DELTA?**

Lists all commands that differ from the defined default status set by [\\*RST](#).

The commands are output with default values, limits and ranges.

**Usage:**                   Query only

---

**SYSTem:PRESet**

Triggers a sensor reset.

The command corresponds to the [\\*RST](#) command.

**Usage:**                   Event

---

**SYSTem:REBoot**

Reboots the power sensor.

**Usage:** Event

---

**SYSTem:REStart**

Restarts the sensor module.

**Usage:** Event

---

**SYSTem:SERRor:LIST:ALL?**

Returns a list of all static errors that have occurred but have already been resolved. For example, an overload of a short duration.

**Example:** SYSTem:SERRor:LIST:ALL?  
**Response:** 0, "reported at uptime:2942; notice; auto-averaging exceeded maximum time; Notification", 0, "removed at uptime:2944; notice; auto-averaging exceeded maximum time; Notification".

**Usage:** Query only

---

**SYSTem:SERRor:LIST[:NEXT]?**

Queries the list of all static errors that have occurred but have already been resolved for the eldest entry and removes it from the queue. The response consists of an error number and a short description of the error.

**Example:** SYST:SERR:LIST?  
Query  
**Response:** 0, "reported at uptime:2942; notice; auto-averaging exceeded maximum time; Notification"

**Usage:** Query only

---

**SYSTem:SERRor?**

Returns the next static error (if any). Static errors are more severe than normal error conditions, which can be queried with `SYSTem:ERRor[:NEXT]?`. While normal errors result from, e.g. unknown commands or syntax errors and generally affect a single parameter or setting, the static errors, usually prevent the execution of normal measurements.

**Usage:** Query only

---

**SYSTem:TLEVels?**

Queries the possible power test levels of the sensor.

**Usage:** Query only

---

**SYSTem:TRANsaction:BEGIN**

Starts a series of settings.

**Usage:** Event

---

**SYSTem:TRANsaction:END**

Ends a series of settings.

**Usage:** Event

---

**SYSTem:VERSion?**

Queries the SCPI version the sensor's command set complies with.

**Example:** `SYSTem:VERSion?`  
Queries the SCPI version.  
Response: 1999.0  
The sensor complies with the SCPI version from 1999.

**Usage:** Query only

---

**SYSTem[:SENSor]:NAME** <sensorname>

Queries the sensor name, or assigns an arbitrary alias name to the sensor.

If not specified, it defaults to the hostname of the sensor module.

**Parameters:**

<sensorname>

**Example:**

```
SYSTem[:SENSor]:NAME
"SensorModuleInput_A90D"
SYSTem[:SENSor]:NAME?
Queries the sensor name.
Response: "SensorModuleInput_A90D"
```

**Manual operation:** See ["Sensor Name"](#) on page 81

## 10.4.2 Handling of available antenna modules

The `SENSe:CHANnel` subsystem contains commands for checking connected antenna modules, and activating individual antenna modules.

Remote commands:

<a href="#">[SENSe&lt;Sensor&gt;:]CHANnel&lt;Channel&gt;:PRESENce?</a> .....	134
<a href="#">[SENSe&lt;Sensor&gt;:]CHANnel&lt;Channel&gt;[:ENABLE]</a> .....	134

---

### **[SENSe<Sensor>:]CHANnel<Channel>:PRESENce?**

Queries whether an antenna module is connected to a channel.

**Suffix:**

<Channel>            1...3

**Usage:**

Query only

**Manual operation:** See ["Antenna"](#) on page 75

---

### **[SENSe<Sensor>:]CHANnel<Channel>[:ENABLE]** <state>

Deactivates channels without an antenna module connected.

**Note:** A sensor module channel which does not have a connected antenna module causes a static error condition. The static error leads to a blinking LED. Therefore we recommend that you disable unconnected channels by this command.

**Suffix:**

&lt;Channel&gt; 1...3

**Parameters:**

&lt;state&gt; \*RST: ON

**Manual operation:** See "Antenna" on page 75

### 10.4.3 Selecting the reference source

The `ROSCillator` subsystem contains commands for configuring the reference source.

---

**[SENSe<Sensor>:]ROSCillator:SOURce** <source>

Selects the source of the reference frequency.

**Parameters:**

&lt;source&gt; INTERNAL | EXTERNAL | HOST

**INTERNAL**

Internal precision oscillator.

**EXTERNAL | HOST**

External signal supplied at the host interface connector.

\*RST: INTERNAL

**Example:** `ROSCillator:SOURce EXTERNAL`

### 10.4.4 Setting the power unit

The `UNIT` subsystem contains command for setting up the power unit.

---

**UNIT:POWER** <unit>

Sets the output unit for the measured power values.

**Parameters:**

&lt;unit&gt; DBM | W

\*RST: W

## 10.4.5 Setting the result format

The `FORMat` subsystem sets the format of numeric data (measured values) that is exchanged between the remote control computer and the sensor modules if high-level measurement commands are used.

Remote commands:

<code>FORMat:BOReDer</code> .....	136
<code>FORMat:SREGister</code> .....	136
<code>FORMat[:DATA]</code> .....	137

---

### `FORMat:BOReDer` <border>

Selects the order of bytes in 64-bit binary data.

#### Parameters:

<border>                    `NORMal` | `SWAPped`

#### **NORMal**

The 1st byte is the LSB, the 8th byte the MSB.

This format fulfills the "Little Endian" convention.

#### **SWAPped**

The 1st byte is the most significant byte (MSB), the 8th byte the least significant byte (LSB).

This format fulfills the "Big Endian" (big end comes first) convention.

\*RST:            `NORMal`

---

### `FORMat:SREGister` <sregister>

Specifies the format used for the return value of `*STB?`.

#### Parameters:

<sregister>                `ASCIi` | `HEXadecimal` | `OCTal` | `BINary`

\*RST:            `ASCIi`



**FORMat[:DATA]** [<data,length>, <length>]

Specifies whether block data is transferred in plain text or binary format.

**Parameters:**

<data,length>	ASCIi   REAL
	<b>ASCIi</b> Transmits data as character strings in plain text.
	<b>REAL</b> Transmits data in binary blocks with 32 bit or 64 bit length.
	*RST:       ASCIi
<length>	Range:       32, 64
	*RST:       32

**Example:**               FORMat:DATA REAL,64  
Binary DOUBLE

FORMat:DATA ASCIi,3  
3.124

## 10.5 Controlling the measurement

The sensor module offers a bunch of possibilities to control the measurement:

- Do you want to start the measurement immediately after the initiate command or do you want to wait for a trigger event?
- Do you want to start a single measurement cycle or a sequence of measurement cycles?
- Do you want to retrieve each new average value as a measurement result or do you want to bundle more measured values into one result?

The following chapter introduces in general the principle of triggering and the controlling mechanisms for the output of the measurement results.

### 10.5.1 Triggering

In a basic continuous measurement, the measurement is started immediately after the initiate command. However, sometimes you want that the measurement starts only if a specific condition is fulfilled. For example, if a signal level is excee-

ded, or in certain time intervals. For these cases, you can define a trigger for the measurement.

## Trigger states

The sensor module has trigger states to define the exact start and stop times of a measurement and the sequence of a measurement cycle.

The following states are defined:

- **Idle**  
The sensor module does not execute a measurement. After powered on, the sensor module is in the idle state.  
When a measurement has been started by one of the `INIT` commands, the sensor module switches to the waiting for trigger state.  
See [Waiting for a trigger event](#).
- **Waiting for trigger**  
The sensor module waits for a trigger event that is defined by the trigger source, see ["Trigger sources"](#) on page 139.  
When the trigger event occurs, the sensor module enters the measuring state.
- **Measuring**  
The sensor module is measuring data. It remains in this state during the measurement. When the measurement is completed, the sensor module either continues with the next measurement, or finishes the current measurement and returns to IDLE state, depending on the initial mode you have started the measurement before.

## Waiting for a trigger event

Before a trigger can be executed, you must set the sensor module to the waiting for trigger state. Depending on whether you want to measure continuously or want to execute one dedicated measurement, use the corresponding command:

- `INITiate:CONTinuous` on page 172  
Starts a new measurement cycle automatically after the previous one has been completed.
- `INITiate[:IMMediate]` on page 171  
Starts a single measurement only. Depending on the selected measurement function, a *single measurement* can lead to an array of results, e.g., in trace mode.  
See `[SENSe<Sensor>:]FUNction` on page 149.

## Trigger sources

The possible trigger conditions and the execution of a trigger depend on the selected trigger source.

If the signal power exceeds or falls below a reference level set by the trigger level, the measurement starts after the defined delay time. Waiting for a trigger event can be skipped by selecting `TRIGger:IMMediate`.

Trigger source	Description	Remote commands to initiate the measurement unconditionally
Hold	Triggered by the remote command.	<code>TRIGger:IMMediate</code>
Immediate	Measures immediately, does not wait for trigger condition.	-
Internal	Uses the input signal as trigger signal.	<code>TRIGger:IMMediate</code>
External 1	Uses the digital input signal supplied using a differential pair in the 8-pin sensor module cable.	<code>TRIGger:IMMediate</code>
External 2	Uses the digital input signal supplied at the SMB connector.	<code>TRIGger:IMMediate</code>
Bus	Triggered by the remote command.	*TRG <code>TRIGger:IMMediate</code>

## Dropout time

The dropout time is useful when dealing with signal with several active slots, for example GSM signals, as, e.g., shown in [Figure 10-1](#). When measuring in sync with the signal, a trigger event is to be produced at A, but not at B or C.

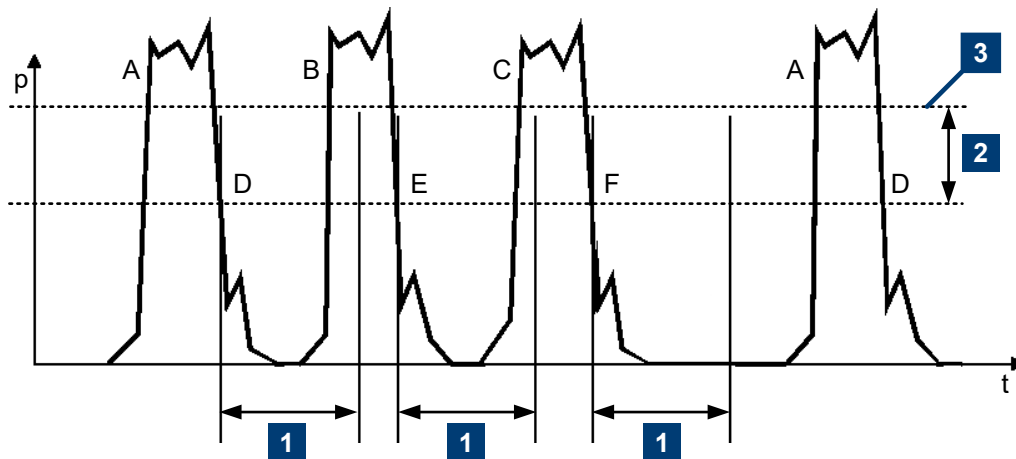

**Figure 10-1: Significance of the dropout time parameter**

- 1 = Dropout time
- 2 = Trigger hysteresis
- 3 = Trigger level

The RF power between the slots is below the threshold defined by the trigger level and the trigger hysteresis. Therefore, the trigger hysteresis alone cannot prevent triggering at B or at C. Therefore, set the dropout time greater than the time elapsed between points D and B and between E and C, but smaller than the time elapsed between F and A. Therefore, ensure that triggering takes place at A.

Because the mechanism associated with the dropout time is reactivated whenever the trigger threshold is crossed, you can obtain also unambiguous triggering for many complex signals.

If you use a hold-off time instead of a dropout time, you can obtain stable triggering conditions - regular triggering at the same point. But you cannot achieve exclusive triggering at A.

### Hold-off time

During the hold-off time, a period after a trigger event, all trigger events are ignored.

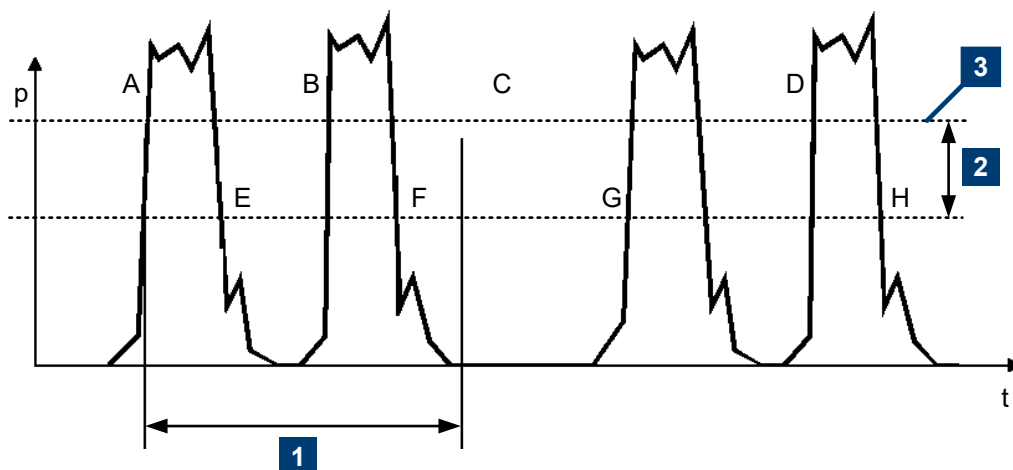

- 1 = Hold-off time
- 2 = Trigger hysteresis
- 3 = Trigger level

## 10.5.2 Controlling the measurement results

The R&S NRPM3(N) sensor module can cope with the wide range of measurement scenarios with the help of the so-called "termination control". Depending on how fast your measurement results change, you can define, how to retrieve the measurement results.

In continuous average mode, use `[SENSe<Sensor>:]AVERAge:TCONtrol`.

In trace mode, use `[SENSe<Sensor>:]TRACe:AVERAge:TCONtrol`.

### Repeating termination control

Returns a measurement result when the average filter has been filled completely. The number of measurement cycle repetitions is equal to the set average count. If the average count is large, the measurement time can take long time.

Useful if you expect slow changes in the results, and you want to avoid the output of redundant data.



Select repeating termination control when executing remote control applications, as you are usually only interested in the results of the fully settled average filter.

### Moving termination control

Returns intermediate values to facilitate early detection of changes in the measured quantity. For each partial measurement, the sensor module returns a new average value as an intermediate measurement result. Thus, the individual result is a moving average of the last partial measurements. The parameter average count defines how many partial measurements are included.



Select the moving termination control when you want to observe and detect trends in the results during an ongoing measurement.

## 10.5.3 Interplay of the controlling mechanisms

The following examples use continuous measurement scenarios. But these scenarios apply also to single measurements. The only difference is that a single measurement is not repeated.

### 10.5.3.1 Continuous average mode

General settings for these examples:

- `INITiate:CONTinuous ON`
- `[SENSe<Sensor>:]AVERage:COUNT 4`
- `[SENSe<Sensor>:]AVERage[:STATe] ON`

**Example: Repeating termination control**

Further settings for this example:

- `[SENSe<Sensor>:]AVERage:TCONtrol REPeat`

The measurement is started by the trigger event. Due to the chopper phases, one measurement lasts twice the defined aperture time. As defined by the average count, after 4 measurements, the result is averaged and available. During the whole measurement cycle, the trigger synchronization is high (`TRIGger:SYNC:STATe ON`).

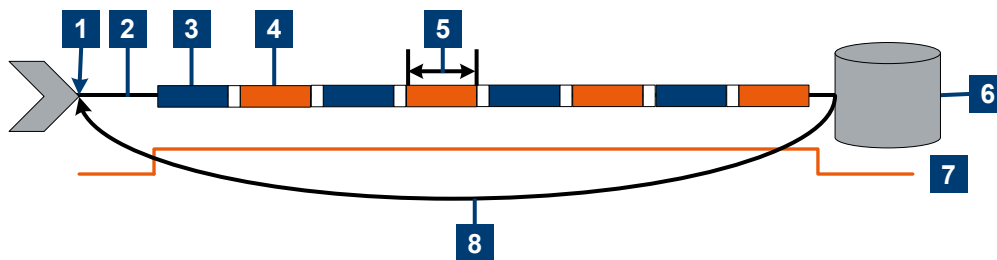

- 1 = Start of the measurement cycle
- 2 = Trigger event
- 3 = Noninverted chopper phase
- 4 = Inverted chopper phase
- 5 = Duration of one aperture time ( $1 \times t_{AP}$ )  $\triangleq$  length of one chopper phase
- 6 = Measurement result
- 7 = Trigger synchronization
- 8 = Return to the start of the measurement cycle

**Example: Moving termination control**

Further settings for this example:

- `[SENSe<Sensor>:]AVERAge:TCONtrol MOVing`
- `TRIGger:COUNT 16`

Every measurement is started by a trigger event. Due to the chopper phases, one measurement lasts twice the defined aperture time. During each measurement, the trigger synchronization is high (`TRIGger:SYNC:STATe ON`). Every measurement provides a result. During the settling phase, the amount of the result is already correct, but the noise is higher. After 4 measurements, when the average count is reached, settled data are available.

When the trigger count is reached (`TRIGger:COUNT`), the sensor module returns to the idle state.

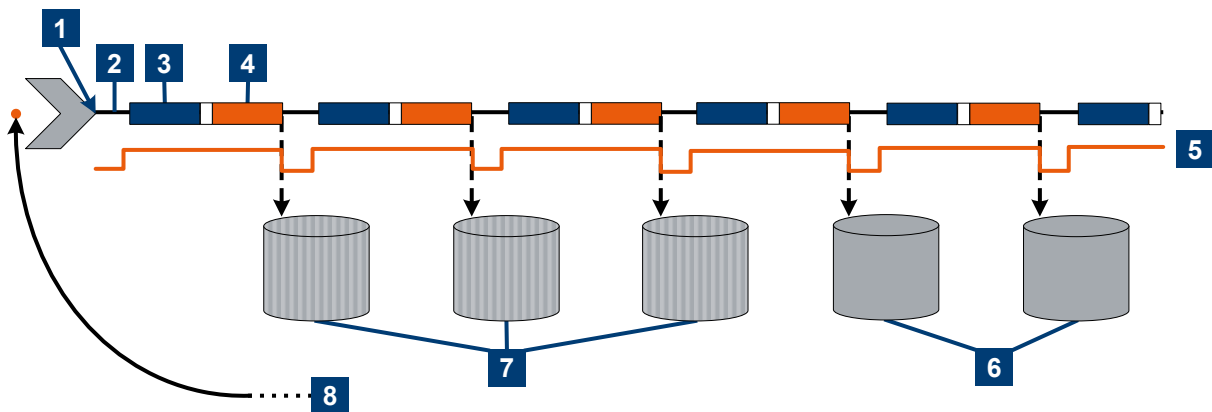

- 1 = Start of the measurement cycle
- 2 = Trigger event
- 3 = Noninverted chopper phase
- 4 = Inverted chopper phase
- 5 = Trigger synchronization
- 6 = Averaged measurement result after average count is reached
- 7 = Measurement result before average count is reached
- 8 = Return to idle state after trigger count (= 16 in this example) is reached



**Example: Average count = 1**

```
[SENSe<Sensor>:]AVERAge:COUNT 1
```

For average count 1, the setting of the termination control has no impact. In both cases, the measurement runs for the duration of one aperture time. Then, settled data are available, and the sensor module returns to the idle state.

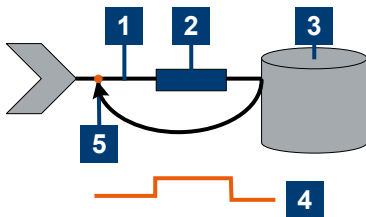

- 1 = Trigger event
- 2 = Noninverted chopper phase
- 3 = Measurement result
- 4 = Trigger synchronization
- 5 = Return to idle state

**10.5.3.2 Trace mode**

General settings for the first two examples:

- `INITiate:CONTInuous ON`
- `[SENSe<Sensor>:]TRACe:AVERAge:COUNT 2` (count 2 is mandatory in trace mode)
- `[SENSe<Sensor>:]TRACe:AVERAge[:STATe] ON`

**Example: Repeating termination control**

Further settings for this example:

- `[SENSe<Sensor>:]TRACe:AVERage:TCONtrol REPeat` (termination control `REPeat` is mandatory in trace mode)

Every chopper phase is started by a trigger event and lasts the defined trace time. During a chopper phase, the trigger synchronization is high (`TRIGger:SYNC:STATe ON`). After 2 chopper phases, 1 measurement is completed. As defined by the trace average count, after 2 measurements, the trace measurement result is averaged and available.

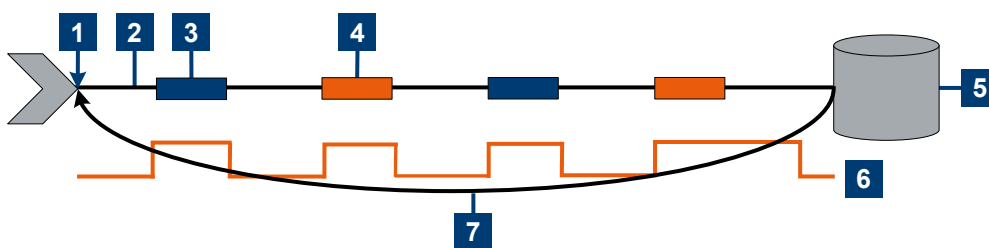

- 1 = Start of the measurement cycle
- 2 = Trigger event
- 3 = Noninverted chopper phase
- 4 = Inverted chopper phase
- 5 = Trace measurement result
- 6 = Trigger synchronization
- 7 = Return to the start of the measurement cycle

**Example: Moving termination control**

Further settings for this example:

- `[SENSe<Sensor>:]TRACe:AVERage:TCONtrol MOVing`

Every chopper phase is started by a trigger event and lasts the defined trace time. During a chopper phase, the trigger synchronization is high (`TRIGger:SYNC:STATe ON`). Every measurement provides a result. After 2 measurements, when the trace average count is reached, settled trace data result is available.

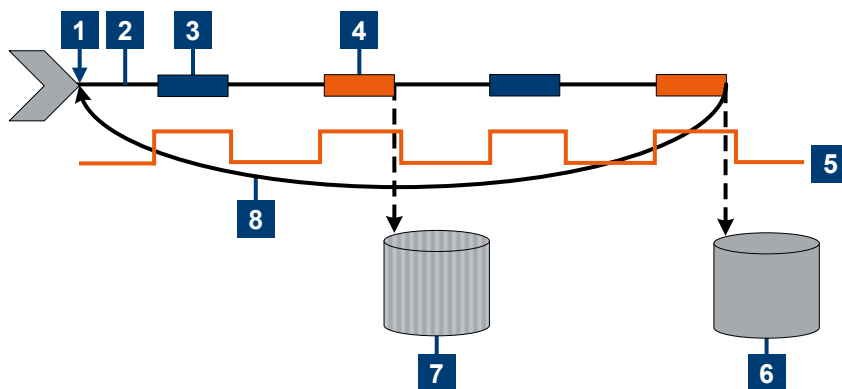

- 1 = Start of the measurement cycle
- 2 = Trigger event
- 3 = Noninverted chopper phase
- 4 = Inverted chopper phase
- 5 = Trigger synchronization
- 6 = Averaged trace data result after trace average count is reached
- 7 = Trace measurement result before trace average count is reached
- 8 = Return to the start of the measurement cycle

## Selecting a measurement mode and retrieving results

**Example: Average count = 1**

```
[SENSe<Sensor>:]TRACe:AVERAge:COUNT 1
```

For average count 1, the setting of the termination control has no impact. In both cases, the measurement runs for the duration of one trace time. Then, settled trace data are available, and the sensor module returns to the idle state.

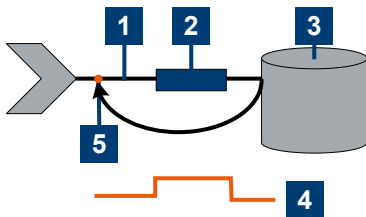

- 1 = Trigger event
- 2 = Noninverted chopper phase
- 3 = Trace measurement result
- 4 = Trigger synchronization
- 5 = Return to idle state

## 10.6 Selecting a measurement mode and retrieving results

Before starting a measurement, select the measurement mode using:

```
[SENSe<Sensor>:]FUNCTION.
```

The following modes are available:

- Continuous average ("POWer:AVG"): After a trigger event, the power is integrated over a time interval, see [Chapter 10.7.1, "Configuring a continuous average measurement"](#), on page 153.
- Trace ("XTIME:POWer"): A sequence of measurements is performed, see [Chapter 10.7.3, "Configuring a trace measurement"](#), on page 157.

After measuring, you can query the measurement results with the correspondent FETCh command.

## Selecting a measurement mode and retrieving results

**Example: Selecting a measurement mode**

```
*RST

// Select continuous average mode
SENSe:FUNcTION "POWer:AVG"

INITiate
FETCh?
```

## Remote commands:

[SENSe<Sensor>:]FUNcTION.....	149
FETCh<Channel>[:SCALar][:POWer][:AVG]?	150
FETCh<Sensor>:ALL[:SCALar][:POWer][:AVG]?	150
CALCulate:FEED.....	150
CALCulate:MATH[:EXPRession].....	151
CALCulate:MATH[:EXPRession]:CATalog?	152
[SENSe<Sensor>:]AUXiliary.....	152

**[SENSe<Sensor>:]FUNcTION <function>**

Sets the measurement mode.

**Parameters:**

<function>

**"POWer:AVG"****Continuous Average**

After a trigger event, the power is integrated over a time interval (aperture) set with [SENSe<Sensor>:] [POWer:] [AVG:] APERture.

**XTIME:POWer****Trace**

In this mode, power over time is measured. Therefore several measurement points are defined ([SENSe<Sensor>:] TRACe:POINts) where the length of an individual measurement is determined from the ratio of total time ([SENSe<Sensor>:] TRACe:TIME) and the defined number of measurement points.

\*RST: "POWer:AVG"

## Selecting a measurement mode and retrieving results

**FETCh<Channel>[:SCALar][:POWer][:AVG]?**

Queries the measurement results of a particular channel of the sensor module.

**Suffix:**

<Channel>                    1...3

**Usage:**                      Query only

**FETCh<Sensor>:ALL[:SCALar][:POWer][:AVG]?**

Queries the measurement results of all channels of a sensor module.

The sensor module returns the results in a string, separated by commas.

**Usage:**                      Query only

**CALCulate:FEED <mode>**

When you query measurement data using `FETCh<Channel>[:SCALar][:POWer][:AVG]?`, the sensor module returns data of the measurand that was configured before, but it can also return data of different measurands. By default, the reading is the average power.

To determine the measurand for the `FETCh<Channel>[:SCALar][:POWer][:AVG]?` command, use the `CALCulate:FEED` before initiating the measurement.

Depending on the measurement mode, the following settings are possible:

<b>SENS:FUNC</b>	<b>Possible CALC:FEED</b>	<b>Meaning</b>
"POWer:AVG"	"POWer:AVERAge"	Average value
	"POWer:PEAK"	Peak value
	"POWer:RANDom"	Randomly selected value from the measurement interval
"XTIME:POWer"	"POWer:TRACe"	Measurement sequence
	"POWer:PEAK:TRACe"	Peak value of the samples per trace point
	"POWer:RANDom:TRACe"	Randomly selected value of the samples per trace point

**Parameters:**

<mode>                      \*RST:                    "POWer:AVERAge"

## Selecting a measurement mode and retrieving results

**Example:**

The following sequence of commands configures a peak trace measurement:

```
SENSe:FUNction "XTIME:POWer"
SENSe:FREQuency 1.0e9
SENSe:TRACe:POINTs 500
SENS:TRAC:TIME 20e-3
TRIGger:SOURce INTernal
TRIGger:SLOPe POSitive
TRIGger:DTIME 0.001
TRIGger:HYSTeresis 0.1
TRIGger:LEVel 30e-6
SENSe:TRACe:AVERAge:COUNT 8
SENSe:TRACe:AVERAge:STATE ON
CALCulate:FEED "POWer:PEAK:TRACe"
INITiate
FETCh?
```

**CALCulate:MATH[:EXPRession] <mode>**

Selects the measurement quantity for the power of the incident electromagnetic wave towards the antenna module.

String	Meaning
"PISotropic"	Equivalent isotropically received power $P_{ISO}$ in W or dBm (default): Equivalent detected power of an isotropic antenna with an ideal power detector at the phase center location of the R&S NRPM antenna module assuming radiation only from boresight direction. $P_{ISO}=P_i$
"PDENsity"	Power density $S$ in $W/m^2$ , calculated as: $S=(4\pi/\lambda^2)\cdot P_{ISO}$
"EFDensity"	Electric field strength $E_{eff}$ in V/m, calculated as: $E_{eff}=\sqrt{S\cdot Z_0}$ with: $Z_0=376,73 \Omega$ .
"MFDensity"	Magnetic field strength $H_{eff}$ in A/m, calculated as: $H_{eff}=\sqrt{S/Z_0}$ with: $Z_0=376,73 \Omega$ .
"DETPower"	Power at the internal RF detector in W or dBm: The measurement result without including antenna gain and frequency-dependent calibration factors is returned. $P_{Det}=(G_{RF,i}/k_{att,A,i}(f))\cdot P_{ISO}$

## Selecting a measurement mode and retrieving results

**Parameters:**

<mode> \*RST: "PISotropic"

**Example:**

CALC:MATH "PDEN"

Selects power density in W/m<sup>2</sup> as the equivalent resulting unit.

**CALCulate:MATH[:EXPRession]:CATalog?**

Lists all supported calculation functions.

The result is a list of strings, separated by comma.

**Example:**

CALC:MATH:CAT?

Response: "PISotropic", "PDENsity",  
"EFDensity", "MFDensity", "DETPower"

**Usage:**

Query only

**[SENSe<Sensor>:]AUXiliary <mode>**

Activates the measurement of additional measurands that are determined together with the main measured value.

**Parameters:**

<mode> NONE | MINMax | RNDMax

**NONE**

No additional values are measured.

**MINMax**

In addition to the average trace, the sensor module also determines the minimum and maximum traces. You can read out the resulting traces (min & max) afterwards with the command [SENSe<Sensor>:]TRACe:DATA??.

**RNDMax**

Determines a trace of randomly selected samples within the min & max range instead of the minimum trace. You can read out the resulting traces (random & max) afterwards with the command [SENSe<Sensor>:]TRACe:DATA??.

\*RST: NONE



## 10.7 Configuring the measurement modes

The following chapter describes the settings needed for configuring a measurement mode.

### 10.7.1 Configuring a continuous average measurement

The "Continuous Average" mode measures the signal average power asynchronously within definable time intervals (sampling windows). The aperture time (width of the sampling windows) can be defined.

#### Reducing noise and zero offset

The continuous average measurement can be performed with chopper stabilization to obtain more accurate results with reduced noise and zero offset. When chopper stabilization is used, a single measurement is performed over two sampling windows, the polarity of the detector output signal being reversed for the second window. By taking the difference of the output signals, the effect of the video path on noise and zero drift is minimized.

The smoothing filter can further reduce result fluctuations caused by modulation. But when activated it increases the inherent noise of the sensor module by approx. 20%, so it should remain deactivated if it is not required.

#### Configuring continuous average measurements of modulated signals

When measuring modulated signals in continuous average mode, the measurement can show fluctuation due to the modulation. If that is the case, adapt the size of the sampling window exactly to the modulation period to get an optimally stable display. If the modulation period varies or is not precisely known, you can also activate the smoothing function.

With smoothing activated, the selected sampling window has to be 5 to 9 times larger than the modulation period for the fluctuations caused by modulation to be sufficiently reduced. The sampling values are subjected to weighting (raised-von-Hann window), which corresponds to video filtering.

If you deactivate the smoothing filter, 300 to 3000 periods are required to obtain the same effect. The sampling values are considered equivalent and averaged in a sampling window, which yields an integrating behavior of the measuring instrument. To obtain optimum suppression of variations in the result, exactly adapt the modulation period to the size of the sampling window. Otherwise, the modulation

## Configuring the measurement modes

can have a considerable influence, even if the sampling window is much larger than the modulation period.

**Calculating the measurement time**

The measurement time is calculated as follows:

$$MT = 2 * AC * APER + (2 * AC - 1) * 100 \mu s$$

with:

MT: overall measurement time

AC: average count

APER: aperture time

100  $\mu$ s is the time for switching the chopper phase.

Remote commands:

[SENSe<Sensor>:][POWER:][AVG:]APERture.....	154
[SENSe<Sensor>:][POWER:][AVG:]BUFFer:CLEar.....	154
[SENSe<Sensor>:][POWER:][AVG:]BUFFer:COUNT?.....	155
[SENSe<Sensor>:][POWER:][AVG:]BUFFer:DATA?.....	155
[SENSe<Sensor>:][POWER:][AVG:]BUFFer:INFO?.....	155
[SENSe<Sensor>:][POWER:][AVG:]BUFFer:SIZE.....	155
[SENSe<Sensor>:][POWER:][AVG:]BUFFer:STATE.....	156
[SENSe<Sensor>:][POWER:][AVG:]SMOothing:STATE.....	156

**[SENSe<Sensor>:][POWER:][AVG:]APERture <integration\_time>**

Sets the aperture, sampling window (time interval) for the continuous average mode. The aperture time defines the length of the unsynchronized time interval used to measure the average signal power.

**Parameters:**

<integration_time>	Range:	10.0e-6 to 2.00
	*RST:	0.02
	Default unit:	s

**Manual operation:** See "[Aperture Time](#)" on page 72

**[SENSe<Sensor>:][POWER:][AVG:]BUFFer:CLEar**

Erases the contents of the result buffer continuous average mode.

## Configuring the measurement modes

**Example:** `[SENSe1:] [POWer:] [AVG:] BUFFer:CLear`

**Usage:** Event

### **[SENSe<Sensor>:][POWer:][AVG:]BUFFer:COUNT?**

Available in continuous average mode.

Queries the number of results that are currently saved in the result buffer.

**Example:** `[SENSe1:] [POWer:] [AVG:] BUFFer:COUNT?`

**Usage:** Query only

### **[SENSe<Sensor>:][POWer:][AVG:]BUFFer:DATA?**

Queries the data of the continuous average result buffer and returns them even if the buffer is not full.

In contrast, `FETCh<Channel> [:SCALar] [:POWer] [:AVG] ?` returns a result only if the buffer is full.

**Example:** `[SENSe1:][POWer:][AVG:]BUFFer:DATA?`

**Usage:** Query only

### **[SENSe<Sensor>:][POWer:][AVG:]BUFFer:INFO? [<ITEM>]**

Queries the data of the continuous average result buffer.

#### **Query parameters:**

<ITEM>

**Example:** `[SENSe1:] [POWer:] [AVG:] BUFFer:INFO?`

**Usage:** Query only

### **[SENSe<Sensor>:][POWer:][AVG:]BUFFer:SIZE <count>**

Sets the size of the result buffer in continuous average mode.

You can enable the buffer using `[SENSe<Sensor>:] [POWer:] [AVG:] BUFFer:STATe`.

## Configuring the measurement modes

**Parameters:**

<count>                    Range:        1 to 8192  
                               \*RST:        1

**Example:**

```
[SENSe<Sensor>:] [POWer:] [AVG:] BUFFer:SIZE
10
```

**[SENSe<Sensor>:][POWer:][AVG:]BUFFer:STATe <state>**

Enables or disables the buffered continuous average mode. If the buffer mode is enabled, all results generated by trigger events are collected in the sensor module until the buffer is filled.

You can set the size of the buffer using `[SENSe<Sensor>:] [POWer:] [AVG:] BUFFer:SIZE`.

**Parameters:**

<state>                    \*RST:        OFF

**Example:**

```
[SENSe<Sensor>:] [POWer:] [AVG:] BUFFer:STATe
OFF
```

**[SENSe<Sensor>:][POWer:][AVG:]SMOothing:STATe <state>**

Activates the smoothing filter, a steep-edge digital lowpass filter. If you cannot adjust the aperture time exactly to the modulation period, the filter reduces result fluctuations caused by modulation.

**Parameters:**

<state>                    ON | OFF  
                               \*RST:        OFF

**Example:**

```
SMOothing:STATe OFF
```

**Manual operation:** See "[Smoothing](#)" on page 73

## 10.7.2 Configuring a list mode measurement

The list mode measurement enables you to execute a sequence of measurements at various frequency points in continuous average mode automatically.

Remote commands:

## Configuring the measurement modes

[SENSe<Sensor>:]LIST:FREQUENCY.....	157
[SENSe<Sensor>:]LIST:FREQUENCY:POINTS?.....	157
CONTRol<Sensor>:FREQUENCY:MODE.....	157

**[SENSe<Sensor>:]LIST:FREQUENCY <frequency>...**

Sets the frequency values for list processing mode.

**Parameters:**

<frequency>            Range:        0 to 110e9  
                              \*RST:        10e9  
                              Default unit: Frequency

**Example:**                [SENSe1:]LIST:FREQUENCY  
                              40e09,45e09,58e09,75e09

**[SENSe<Sensor>:]LIST:FREQUENCY:POINTS?**

Sets the number (points) of frequency entries in list processing mode.

**Example:**                [SENSe1:]LIST:FREQUENCY:POINTS 4

**Usage:**                    Query only

**CONTRol<Sensor>:FREQUENCY:MODE <mode>**

Selects the frequency list mode.

**Parameters:**

<mode>                    FIXed | RXList  
                              \*RST:        FIXed

**Example:**                CONTRol1:FREQUENCY:MODE RXList

**10.7.3 Configuring a trace measurement**

The trace measurement is used to acquire the course of power over a certain time. During the measurement time ([SENSe<Sensor>:]TRACe:TIME) a large number of measurements are made and the result is returned to the user as an array of values with a predefined size [SENSe<Sensor>:]TRACe:POINTS. The length of an individual measurement(-point) is determined from the ratio of mea-

## Configuring the measurement modes

surement time and measurement points. The entire result is called a "trace". Each trace must be triggered separately.

Remote commands:

[SENSe<Sensor>:]TRACe:AVERAge:COUNT.....	158
[SENSe<Sensor>:]TRACe:AVERAge:TCONtrol.....	158
[SENSe<Sensor>:]TRACe:AVERAge[:STATe].....	159
[SENSe<Sensor>:]TRACe:DATA?.....	159
[SENSe<Sensor>:]TRACe:MPWidth?.....	163
[SENSe<Sensor>:]TRACe:OFFSet:TIME.....	163
[SENSe<Sensor>:]TRACe:POINts.....	163
[SENSe<Sensor>:]TRACe:REALtime.....	163
[SENSe<Sensor>:]TRACe:TIME.....	164
[SENSe<Sensor>:]TRACe:UPSample[:TYPE].....	164

---

### [SENSe<Sensor>:]TRACe:AVERAge:COUNT <count>

Sets the trace filter length, i.e. the number of acquired traces which are to be averaged for one trace. The higher the count the lower the noise and the longer it takes to obtain a trace result.

#### Parameters:

<count>	Range:	1 to 65536
	*RST:	4

---

### [SENSe<Sensor>:]TRACe:AVERAge:TCONtrol <mode>

Sets the termination control mode for trace mode, defining how you retrieve the measurement results.

When a new intermediate trace is shifted to the FIR filter, a new average trace is available at the filter output. It is composed of the last acquired trace and the other trace data already stored in the filter.

See [Chapter 10.5.2, "Controlling the measurement results"](#), on page 141.

#### Parameters:

<mode>	MOVing   REPeat
--------	-----------------

## Configuring the measurement modes

**MOVing**

Returns each new average trace as a measurement result, even if the FIR filter is not yet filled completely with measured traces.

This mode is suitable for measurements, where tendencies in the result have to be recognized during the measurement procedure.

**REPeat**

Returns a final trace result only after the FIR filter has been filled with acquired traces.

This mode is suitable to avoid redundant results in measurements.

\*RST: REPeat

**Example:**

TRACe:AVERAge:TCONtrol REPeat

**[SENSe<Sensor>:]TRACe:AVERAge[:STATe] <state>**

Activates the averaging filter in trace mode.

**Parameters:**

<state> \*RST: ON

**[SENSe<Sensor>:]TRACe:DATA?**

Returns the measured trace data in a pre-defined format. Unlike the `FETCh?` command, this command considers the settings of `[SENSe<Sensor>:]AUXiliary` on page 152 as explained below.

**Command response**

Besides the average power, the R&S NRPM sensor module can measure additional measurands like "Minimum", "Maximum" or "Random". These additional measurands are denoted as auxiliary measurands and are selected by the `[SENSe<Sensor>:]AUXiliary` on page 152 command.

Configuring the measurement modes

A trace measurement with the R&S NRPM can therefore be configured to return up to three measurands on each channel/antenna module. As a consequence, the resulting data which is provided by a `[SENSE<Sensor>:]TRACe:DATA` query can contain between 1 and 9 blocks of measurement data. For example, 1 resulting measurement data block if only one antenna module is used and only average power is to be measured on that channel. 9 resulting measurement data blocks if three antenna modules are used and average, min & max power is to be measured on each channel.

To obtain a single measurement data block, you must first extract the contents of the "Definite Length Arbitrary Block" which is returned from the `SENSE:TRACe:DATA` query. The format is defined in IEEE488.2.

In principle the response has the format as shown in [Figure 10-2](#):

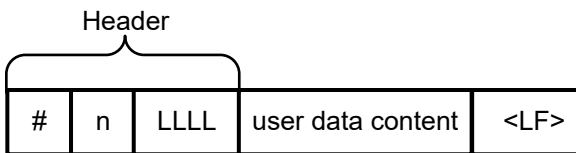

**Figure 10-2: Response format**

Header	#	Starting character
	n	Single digit that defines how many of the following digits are interpreted as the size of the content.
	LLLLL	Number consisting of as many digits as specified by "n". This number determines the size of the content.
User data content	See <a href="#">Figure 10-3</a> . As many bytes as specified by "LLLLL".	
<LF>	Single linefeed character	

**Example:**

The arbitrary block response data for a user data that contains 45182 bytes is:

#545182xxxxxx.....xxxxxx <LF>

The arbitrary block response data for a user data content 'THIS IS A TEST' is:

#214THIS IS A TEST<LF>

Explanation: 'THIS IS A TEST' has 14 bytes, and '14' has 2 digits, hence the #214.



## User-data-content

In the further description, the term "user data content" is used for the totality of the contained measurement results.

In the user data content, there are similar mechanisms as with arbitrary block response data. As indicated above, the user data content can have one or more blocks with trace measurement results, depending on the selection of auxiliary measurands. Each section is composed of:

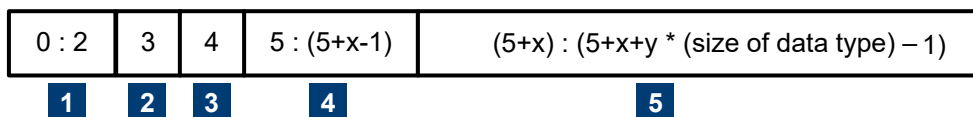

**Figure 10-3: User data content format (byte)**

y = number of values which follow the header

x = number of digits of y

<b>1</b>	Result type Always 3 bytes, one for <code>AVG</code> , one for <code>MIN</code> and one for <code>MAX</code> or <code>RND</code>
<b>2</b>	Data type Designator for the contained data type with the size of 1 byte. Currently, the only possible designator is "f" for 4-byte IEEE754 float data type, little endian.
<b>3</b>	Single digit that defines how many of the following digits are interpreted as the number of contained float values.
<b>4</b>	User data length Number consisting of as many digits as specified by (3). This number gives the number of contained float values contained in the user data.
<b>5</b>	User data Measurement result values in the format that is described by the data type. Currently IEEE754 float only.

## Configuring the measurement modes

**Example:**

```

C1Af3260xxxxyyyy
C1
  A      Channel 1
         The letter 'A' to denote
           the Average-Trace
  f      The letter 'f' to denote
           float format
  3      3 bytes for length of the number
           of points that follows
  260    260 float values (4 bytes each)
  xxxxyyyy... 260 float values...

```

This example shows one of up to nine measurement data blocks which could be contained in the user data content. Referring to the example above, if the min and max traces are also selected (by `SENS:AUX MINMAX`) the subsequent data would contain:

```

C1mf3260mmmmnnnn
C1
  m      Channel 1
         The letter 'm' to denote
           the Min-Trace
  f      The letter 'f' to denote
           float format
  3      3 bytes for length of the
           number of points that follows
  260    260 float values (4 bytes each)
  mmmnnnn... 260 float values...

C1Mf3260gggghhhh
C1
  M      Channel 1
         The letter 'M' to denote
           the Max-Trace
  f      The letter 'f' to denote
           float format
  3      3 bytes for length of the
           number of points that follows
  260    260 float values (4 bytes each)
  gggghhhh... 260 float values...

```

For further information, see the ... [NRPM3] \Trace-M3 \Visa \visaTraceBinaryData-M3 project from the accompanying programming examples (included). The source-code shows how to extract the measurement data from the "user-data-content".

**Usage:** Query only

### [SENSe<Sensor>:]TRACe:MPWidth?

Queries the attainable time resolution of the trace mode. The result is the smallest possible distance between two pixels, i.e. it is the smallest time interval that can be assigned to a pixel.

**Usage:** Query only

### [SENSe<Sensor>:]TRACe:OFFSet:TIME <time>

Sets the relative position of the trigger event in relation to the beginning of the trace measurement sequence. It is used to specify the start of recording for trace mode.

The start of recording is referenced to the delayed trigger point that is set with [TRIGger:DElay](#). Negative values indicate that the start of recording occurs before the trigger point.

**Parameters:**

<time>	Range:	-3.0 to 3.0
	*RST:	0.0
	Default unit:	s

**Manual operation:** See "[Trace Offset Time](#)" on page 74

### [SENSe<Sensor>:]TRACe:POINTs <points>

Sets the number of required values per trace sequence.

**Parameters:**

<points>	Range:	1 to 100000
	*RST:	260

**Manual operation:** See "[Trace Points](#)" on page 74

### [SENSe<Sensor>:]TRACe:REALtime <state>

Activates realtime processing of the trace mode.

## Configuring the measurement modes

If disabled, each measurement from the sensor module is averaged. If enabled, only one sampling sequence per measurement is recorded, thus increasing the measurement speed. With a higher measurement speed, the measured values of an individual measurement are immediately delivered.

The averaging filter is not used, i.e. the following settings are ignored:

- `[SENSe<Sensor>:]TRACe:AVERage[:STATe]`
- `[SENSe<Sensor>:]TRACe:AVERage:COUNT`

**Parameters:**

<state>                      \*RST:              OFF

**[SENSe<Sensor>:]TRACe:TIME <time>**

Sets the trace length, i.e. the time to be covered by the trace sequence. This time period is divided into several equal intervals, in which the average power is determined. The number of intervals equals the number of trace points, which is set with the command `[SENSe<Sensor>:]TRACe:POINTs`.

**Parameters:**

<time>                      Range:              10.0e-6 to 3.0  
                                  \*RST:              0.01  
                                  Default unit: Seconds

**Manual operation:**    See "[Trace Time](#)" on page 73

**[SENSe<Sensor>:]TRACe:UPSample[:TYPE] <type>**

Selects an output mode for the acquired trace data.

**Parameters:**

<type>                      SINC | HOLD

**HOLD**

Returns the trace data unchanged. The course of power over time is represented as sampled by the sensor module's data acquisition and processing logic.

## Configuring basic measurement parameters

**SINC**

Returns the trace data as the result of a SINC interpolation of the acquired samples. This setting is only reasonable if the selected number of trace points is higher than the number of samples which results from the internal sample rate in the selected trace time. The SINC interpolation reconstructs the original signal sequence best from the sampled values. Use it to get a smooth resulting curve.

\*RST: SINC

**Example:**

```
SENS:TRAC:TIME 100E-6
```

Sets the trace time to 100  $\mu$ s. With an internal sample rate of 2 MHz, the sensor module performs 200 measurements.

```
SENS:TRAC:POIN 400
```

```
SENS1:TRACe:UPS:TYPE SINC
```

If you select the number of trace points higher than the number of physical measurements, you achieve a smooth result curve using the SINC interpolation.

```
SENS:TRAC:POIN 200
```

```
SENS1:TRACe:UPS:TYPE SINC
```

If the trace points are up to the number of physical measurements, the SINC interpolation does not affect the trace results.

## 10.8 Configuring basic measurement parameters

The following section describes the settings common for several measurement modes.

### 10.8.1 Configuring averaging

This chapter includes the commands required for averaging in the continuous average measurements.

Remote commands:

## Configuring basic measurement parameters

[SENSe<Sensor>:]AVERAge:COUNT.....	166
[SENSe<Sensor>:]AVERAge:RESet.....	166
[SENSe<Sensor>:]AVERAge:TCONtrol.....	167
[SENSe<Sensor>:]AVERAge[:STATe].....	167

**[SENSe<Sensor>:]AVERAge:COUNT <count>**

Sets the number of readings that are averaged for one measured value. The higher the count, the lower the noise, and the longer it takes to obtain a measured value.

Average count is often also called averaging factor, but it designates the same parameter, i.e the number of measured values that have to be averaged for forming the measurement result.

Averaging is only effective, when [SENSe<Sensor>:]AVERAge[:STATe] is turned on.

**Parameters:**

<count>	Range:	1 to 65536
	*RST:	4

**Example:** AVERAge:COUNT 4

**Manual operation:** See "<Value>" on page 77

**[SENSe<Sensor>:]AVERAge:RESet**

Deletes all previous measurement results that the averaging filter contains and initializes the averaging filter. The filter length gradually increases from 1 to the set averaging factor. Thus, trends in the measurement result become quickly apparent. Note that the measurement time required for the averaging filter to settle completely remains unchanged.

Use this command if:

- A high averaging factor is set.  
[SENSe<Sensor>:]AVERAge:COUNT
- Intermediate values are output as measurement results.  
[SENSe<Sensor>:]AVERAge:TCONtrol MOVing.
- Power has significantly decreased since the previous measurement, for example by several powers of 10.

## Configuring basic measurement parameters

In this case, previous measurement results still contained in the averaging filter strongly affect the settling of the display. As a result, the advantage of detecting trends in the measurement result while the measurement is still in progress, is lost.

**Example:** `AVERage:RESet`

**Usage:** `Event`

### [SENSe<Sensor>:]AVERage:TCONtrol <mode>

Sets the termination control mode for averaging mode, defining how you retrieve the measurement results.

When a new measured value is shifted to the FIR filter, a new average value is available at the filter output. It is composed of the last measured value and the other values already stored in the filter.

See [Chapter 10.5, "Controlling the measurement"](#), on page 137.

#### Parameters:

<mode>

MOVing | REPeat

#### **MOVing**

Provides every new average value at the output as a measurement result.

This mode is suitable for measurements, where tendencies in the result have to be recognized during the measurement procedure.

#### **REPeat**

A new result is output after the FIR filter has been filled with new measured values.

This mode is suitable for measurements, where no redundant information has to be output.

\*RST: `REPeat`

**Example:** `AVERage:TCONtrol REPeat`

**Manual operation:** See ["Filter Terminal Control"](#) on page 77

### [SENSe<Sensor>:]AVERage[:STATe] <state>

Activates the averaging filter for the continuous average mode.

**Parameters:**

<state>                    \*RST:            ON

**Manual operation:**    See "<Mode>" on page 77

## 10.8.2 Setting the frequency

The frequency of the signal to be measured is not automatically determined. For achieving better accuracy, the carrier frequency of the applied signal must be set.

[SENSe<Sensor>:]FREQuency..... 168

---

### [SENSe<Sensor>:]FREQuency <frequency>

Transfers the carrier frequency of the RF signal to be measured. This frequency is used for the frequency-response correction of the measurement result.

The center frequency is set for broadband signals, e.g. spread-spectrum signals, multicarrier signals.

The data of the connected antenna module determines the frequency limits.

**Parameters:**

<frequency>            Range:            antenna-specific  
                              \*RST:            10.0e9  
                              Default unit: Hz

**Example:**                FREQuency 4.2e10

**Manual operation:**    See "Frequency" on page 71

## 10.8.3 Configuring corrections

It is possible to set some parameters that compensate for a change of the measured signal due to fixed external influences.

- [Duty cycle corrections](#)..... 169
- [Offset corrections](#)..... 169



### 10.8.3.1 Duty cycle corrections

The duty cycle is the percentage of one period in which the signal is active, when pulse-modulated signals are corrected. The duty cycle is only evaluated in the Continuous Average mode.

Remote commands:

[SENSe<Sensor>:]CORRection:DCYClE.....	169
[SENSe<Sensor>:]CORRection:DCYClE:STATe.....	169

---

#### [SENSe<Sensor>:]CORRection:DCYClE <duty\_cycle>

Effective in continuous average mode.

Sets the duty cycle for measuring pulse-modulated signals. The duty cycle defines the percentage of one period when the signal is active.

If the duty cycle is enabled, the R&S NRPM calculates the signal pulse power from the average power considering the duty cycle in percent.

#### Parameters:

<duty_cycle>	Range:	0.001 to 100.00
	*RST:	1.00
	Default unit:	Percent

**Example:** CORRection:DCYClE 0.01

**Manual operation:** See "[Duty Cycle](#)" on page 73

---

#### [SENSe<Sensor>:]CORRection:DCYClE:STATe <state>

Activates the duty cycle correction for the measured value.

#### Parameters:

<state>	*RST:	OFF
---------	-------	-----

**Example:** CORRection:DCYClE:STATe ON

**Manual operation:** See "[Duty Cycle](#)" on page 73

### 10.8.3.2 Offset corrections

The offset accounts for external losses by adding a fixed level offset in dB.

## Starting and ending a measurement

The attenuation of an attenuator located ahead of the sensor module (or the coupling attenuation of a directional coupler) is considered with a positive offset, i.e. the sensor module calculates the power at the input of the attenuator or the directional coupler. You can use a negative offset to compensate the influence of an upstream amplifier.

Remote commands:

[SENSe<Sensor>:]CORRection:OFFSet.....	170
[SENSe<Sensor>:]CORRection:OFFSet:STATe.....	170

---

**[SENSe<Sensor>:]CORRection:OFFSet <offset>**

Sets a fixed offset that is added to correct the measured value.

**Parameters:**

<offset>                      Range:        -200.00 to 200.00  
                                  \*RST:        0  
                                  Default unit: dB

**Example:**                      CORRection:OFFSet 2

**Manual operation:**    See "<Value>" on page 71

---

**[SENSe<Sensor>:]CORRection:OFFSet:STATe <state>**

Activates the offset correction.

**Parameters:**

<state>                      \*RST:        OFF

**Example:**                      CORRection:OFFSet:STATe ON

**Manual operation:**    See "<State>" on page 71

## 10.9 Starting and ending a measurement

ABORt.....	171
INITiate:ALL.....	171
INITiate[:IMMediate].....	171
INITiate:CONTInuous.....	172

**ABORT**

Immediately interrupts the current measurement.

Depending on the selected measurement mode, the trigger system of the sensor module exits the measuring state and switches to:

- Idle state  
If a single measurement was previously initiated with command `INITiate[:IMMediate]`, or `INITiate:ALL`.
- Waiting for trigger  
If a continuous measurement was initiated with `INITiate:CONTInuous ON`. The sensor module starts the next measurement when a trigger event occurs that meets the set trigger conditions.

**Usage:** Event

---

**INITiate:ALL****INITiate[:IMMediate]**

Starts a single measurement cycle. The sensor module changes from the idle state to the wait for trigger state. When the trigger condition is fulfilled, the sensor module starts measuring. Depending on the number of trigger events that are required, e.g. for averaging, the sensor module enters the wait for trigger state several times. When the entire measurement is completed, the measurement readings are available, and the sensor module returns to the idle state.

Use the command only after the continuous measurement mode has been turned off (`INITiate:CONTInuous OFF`).

**Example:** See [Chapter 11.2, "Performing measurements in continuous average mode"](#), on page 187.

**Usage:** Event

**INITiate:CONTInuous** <state>

Activates the continuous measurement mode. In continuous measurement mode, the sensor module does not change to idle state after a measurement cycle has been completed, but enters the wait for trigger state. When a trigger event occurs, it starts the next measurement cycle. This mode is also known as free-running mode, although each measurement cycle depends on the trigger conditions.

**Parameters:**

&lt;state&gt;

**ON**

Measures continuously. If a measurement is completed, the sensor module enters the wait for trigger state again.

**OFF**

Stops the continuous measurement mode. The sensor module switches to idle state.

\*RST: OFF

**Example:**

See [Chapter 11.2, "Performing measurements in continuous average mode"](#), on page 187.

**Manual operation:**

See ["Measurement"](#) on page 71

## 10.10 Configuring the trigger

Further information:

- [Chapter 10.5, "Controlling the measurement"](#), on page 137

Remote commands:

<a href="#">TRIGger:BURSt:DELay</a> .....	173
<a href="#">TRIGger:ATRigger:DELay</a> .....	173
<a href="#">TRIGger:ATRigger:EXECuted?</a> .....	173
<a href="#">TRIGger:ATRigger[:STATe]</a> .....	174
<a href="#">TRIGger:COUNt</a> .....	174
<a href="#">TRIGger:DELay</a> .....	174
<a href="#">TRIGger:DELay:AUTO</a> .....	175
<a href="#">TRIGger:DTIME</a> .....	175
<a href="#">TRIGger:EXTernal&lt;2...2&gt;:IMPedance</a> .....	175
<a href="#">TRIGger:HOLDoff</a> .....	176
<a href="#">TRIGger:HYSTeresis</a> .....	176

## Configuring the trigger

TRIGger:IMMediate.....	176
TRIGger:LEVel.....	176
TRIGger:LEVel:UNIT.....	177
TRIGger:SENDER:PORT.....	177
TRIGger:SENDER:STATE.....	178
TRIGger:SLOPe.....	178
TRIGger:SOURce.....	178
TRIGger:SYNC:PORT.....	180
TRIGger:SYNC:STATE.....	180

**TRIGger:BURSt:DELay** <delay>

List processing mode only

Sets the initial delay after the start burst until the first measurement starts.

**Parameters:**

<delay>                      Range:        10e-6 to 1  
                                  \*RST:        1e-3  
                                  Default unit: Seconds

**Example:**                      TRIGger:BURSt:DELay 2e-3

**TRIGger:ATRigger:DELay** <delay>

For `TRIGger:ATRigger[:STATE] ON`, this parameter determines after which time an artificial trigger event is created, if no real trigger event has occurred.

**Parameters:**

<delay>                      Range:        250e-6 to 5.0  
                                  \*RST:        0.3  
                                  Default unit: s

**TRIGger:ATRigger:EXECuted?**

Queries the number of measurements which were triggered automatically, provided `TRIGger:ATRigger[:STATE]` is activated.

In scalar measurements, this number can only be 0 or 1. If you execute a buffered measurement the number indicates how many results in the returned array of measurement data were executed without a real trigger event.

**Usage:**                      Query only

**TRIGger:ATRigger[:STATe]** <state>

Activates the artificial trigger.

An artificial trigger is generated if the time set with `TRIGger:ATRigger:DElay` has elapsed after the start of measurement and no trigger event has occurred.

**Parameters:**

<state>                    \*RST:            OFF

**Example:**                    TRIG:ATR:STAT ON

**TRIGger:COUNT** <count>

Sets the number of measurement cycles to be performed when the measurement is started. This number equals the number of results which can be obtained from the sensor module after a single `INITiate[:IMMediate]`. As long as the defined number of measurements are not yet executed, the sensor module automatically initiates another measurement internally after the current result is available.

Use this command in particular in conjunction with buffered measurements, for example, to fill a buffer with a predefined size with measurements which have been triggered with the command `*TRG` or with the configured trigger condition.

**Parameters:**

<count>                    Range:            1 to 8192  
                              \*RST:            1

**TRIGger:DElay** <delay>

Sets the delay between the trigger event and the beginning of the actual measurement (integration).

**Parameters:**

<delay>                    Range:            -5.0 to 10.0  
                              \*RST:            0.0  
                              Default unit: s

**Manual operation:**    See "[Trigger Delay](#)" on page 79

**TRIGger:DElay:AUTO** <state>

Activates the automatic setting of the delay time.

If activated, the measurement starts only after the R&S NRPM input is settled.

The function determines the delay value automatically. It is ignored if the set **TRIGger:DElay** time is longer than the automatically determined value.

**Parameters:**

<state>                    \*RST:            OFF

**Manual operation:**    See "[Trigger Delay](#)" on page 79

**TRIGger:DTIME** <dropout\_time>

Sets the dropout time for the internal trigger source. During this time, the signal power must exceed (negative trigger slope) or undercut (positive trigger slope) the level defined by the trigger level **TRIGger:LEVel** and and trigger hysteresis **TRIGger:HYSTeresis**.

At least, this time must elapse before triggering can occur again.

See "[Dropout time](#)" on page 139

**Parameters:**

<dropout\_time>            Range:            0.00 to 10.00  
                                 \*RST:            0.00  
                                 Default unit: s

**Manual operation:**    See "[Dropout](#)" on page 79

**TRIGger:EXTernal<2...2>:IMPedance** <impedance>

Sets the termination resistance of the second external trigger input (**EXTernal2**). You can select between **HIGH** (~ 10 kOhm) and **LOW** (50 Ohms) to fit the impedance of the trigger source and thus minimize reflections on the trigger signals.

**Suffix:**

<2...2>                    2...2

**Parameters:**

<impedance>              HIGH | LOW  
                                 \*RST:            HIGH

**TRIGger:HOLDoff** <holdoff>

Sets the hold off time, see ["Hold-off time"](#) on page 140.

**Parameters:**

<holdoff>                      Range:        0.00 to 10.00  
                                     \*RST:        0.00  
                                     Default unit: s

**Manual operation:**    See ["Holdoff"](#) on page 79

---

**TRIGger:HYSteresis** <hysteresis>

Sets the hysteresis thresholds. A trigger event occurs, if the trigger level:

- Falls below the set value on a rising slope.
- Rises above the set value on a falling slope.

You can use the hysteresis to eliminate the effects of noise in the signal on the edge detector of the trigger system.

**Parameters:**

<hysteresis>                    Range:        0.00 to 10.00  
                                     \*RST:        0.00  
                                     Default unit: dB

**Manual operation:**    See ["Hysteresis"](#) on page 79

---

**TRIGger:IMMediate**

Triggers a generic trigger event that causes the sensor module to exit the WAIT\_FOR\_TRIGGER state immediately, irrespective of the trigger source and the trigger delay and start the measurement. The command is the only means of starting a measurement when the trigger source is set to HOLD. Only one measurement cycle is executed irrespective of the averaging factor.

**Usage:**                        Event

---

**TRIGger:LEVel** <level>

Sets the trigger threshold for internal triggering derived from the test signal.

This setting is effective only for the internal [TRIGger:SOURce](#).



**Parameters:**

<level>                    Range:        1.0e-7 to 200.0e-3  
                               \*RST:        1.0e-3  
                               Default unit: W

**Manual operation:**    See "[Trigger Level](#)" on page 79

**TRIGger:LEVel:UNIT** <unit>

Sets the unit of the trigger level if this value is entered without a unit.

See [TRIGger:LEVel](#).

**Parameters:**

<unit>                    DBM | W | DBUV  
                               \*RST:        W

**Example:**                TRIGger:LEVel:UNIT W

**Manual operation:**    See "[Trigger Level](#)" on page 79

**TRIGger:SENDER:PORT** <sender\_port>

Selects the port where the R&S NRPM provides its internal trigger signal at the output, provided it is trigger sender (see [TRIGger:SENDER:STATE](#)).

You can assign either the port `EXTernal[1]` or `EXTernal2` for the trigger sender. If you want to trigger the sender sensor module externally with its own trigger signal, assign the trigger source to the other port accordingly, e.g:

```
TRIGger:SENDER:PORT EXT1
TRIGger:SOURce        EXT2
TRIGger:SENDER:
STATE                  ON
```

or

```
TRIGger:SENDER:PORT EXT2
TRIGger:SOURce        EXT1
TRIGger:SENDER:
STATE                  ON
```

**Parameters:**

<sender\_port>           EXT1 | EXTERNAL1 | EXT2 | EXTERNAL2  
\*RST:                EXT1

---

**TRIGGER:SENDER:STATE <state>**

Activates the trigger sender mode of the sensor module. In this state, the sensor module can output a digital trigger signal in synchronization with its own trigger event.

If activated, select the output port the trigger signal using [TRIGGER:SENDER:PORT](#).

Typically, the trigger sender uses its internal trigger source. But you can also trigger the trigger sender externally, since the R&S NRPM provides two external trigger connectors. If you trigger the sender externally, use `EXTERNAL1` as external trigger input port (trigger source) and `EXTERNAL2` as trigger sender output port or vice versa.

**Parameters:**

<state>                \*RST:        OFF

---

**TRIGGER:SLOPE <slope>**

Available only if [TRIGGER:SOURCE INTERNAL/EXTERNAL](#).

Determines what is used for triggering, depending on the trigger source:

- [TRIGGER:SOURCE INTERNAL](#): uses the rising or falling edge of the envelope power.
- [TRIGGER:SOURCE EXTERNAL](#): uses the increasing voltage.

**Parameters:**

<slope>                POSITIVE | NEGATIVE  
\*RST:                POSITIVE

**Manual operation:**    See "[<Slope>](#)" on page 78

---

**TRIGGER:SOURCE <source>**

Selects the source for the trigger event detector.

See [Chapter 10.5.1, "Triggering"](#), on page 137.

### Parameters:

<source>            HOLD | IMMEDIATE | INTERNAL | INT1 | INT2 | INT3 |  
 INTERNAL1 | INTERNAL2 | INTERNAL3 | BUS | EXTERNAL | EXT1 |  
 EXTERNAL1 | EXT2 | EXT3 | EXTERNAL2 | EXTERNAL3 |  
 BURST1 | BURST2 | BURST3 | BURS1 | BURS2 | BURS3

#### **BUS**

Triggers the measurement with the commands `*TRG` or `TRIGGER:IMMEDIATE`, where `TRIGGER:IMMEDIATE` shortens the measurement. In this case, the other trigger settings are meaningless.

#### **EXTERNAL**

Initiates the measurement by the hardware trigger bus, e.g. of the base unit. Waiting for a trigger event can be skipped by `TRIGGER:IMMEDIATE`.

`EXT`, `EXT1`, `EXTERNAL` and `EXTERNAL1` denote the same, an external trigger is applied through the round 8 pin connector.

`EXT2` and `EXTERNAL2` refer to external triggering initiated by the dedicated SMB type connector, TRIG2 I/O, at the rear of the sensor module.

#### **HOLD**

Triggers the measurement with the command `TRIGGER:IMMEDIATE`.

#### **IMMEDIATE**

Starts the measurement immediately.

#### **INTERNAL | INT1 | INT2 | INT3**

Determines to consider the RF signal level at the specified antenna (1, 2 or 3) for launching a measurement. The parameter `INTERNAL` is a synonym for `INT1` | `INTERNAL1`.

The measurement starts when the signal exceeds (`TRIGGER:SLOPE POSITIVE`) or drops below (`TRIGGER:SLOPE NEGATIVE`) the power set with `TRIGGER:LEVEL`, after the `TRIGGER:DELAY` has elapsed. Similar to trigger source `EXT`, waiting for a trigger event can also be skipped by `TRIGGER:IMMEDIATE`.

\*RST:            IMMEDIATE

**Manual operation:** See "[Source](#)" on page 78

### TRIGger:SYNC:PORT <sync\_port>

Selects the external connection for the sensor module's sync output, see also [TRIGger:SYNC:STATE](#).

**Parameters:**

<sync\_port>           EXT1 | EXTERNAL1 | EXT2 | EXTERNAL2  
 \*RST:                EXT1

### TRIGger:SYNC:STATE <state>

Usually used in combination with [TRIGger:SENDER:STATE ON](#).

If activated, blocks the external trigger bus as long as the sensor modules remains in the measurement state.

This function makes sure, that a new measurement only starts after all sensor modules have completed their last measurement.

Make sure that the number of repetitions is the same for all the sensor modules involved in the measurement. Otherwise, the trigger bus is blocked by any sensor module that has completed its measurements before other sensor module and has returned to the IDLE state.

**Parameters:**

<state>                \*RST:        OFF

## 10.11 Using the status register

Further information:

- [Chapter 9.2, "Status reporting system"](#), on page 95

Contents:

- [General status register commands](#)..... 181
- [Reading out the CONDITION part](#)..... 181
- [Reading out the EVENT part](#)..... 182

- [Controlling the ENABLE part](#)..... 182
- [Controlling the negative transition part](#)..... 183
- [Controlling the positive transition part](#)..... 184

### 10.11.1 General status register commands

Remote commands:

<a href="#">STATus:PRESet</a> .....	181
<a href="#">STATus:QUEue[:NEXT]?</a> .....	181

---

#### STATus:PRESet

Resets the edge detectors and `ENABLE` parts of all registers to a defined value.

**Usage:**                      Event

---

#### STATus:QUEue[:NEXT]?

Queries the most recent error queue entry and deletes it.

Positive error numbers indicate sensor module specific errors. Negative error numbers are error messages defined by SCPI.

If the error queue is empty, the query returns 0 ("No error").

**Usage:**                      Query only

### 10.11.2 Reading out the CONDition part

For more information on the CONDition part see [Chapter 9.2.2, "Structure of an SCPI status register"](#), on page 97.

---

**STATus:DEvice:CONDition?**  
**STATus:OPERation:CALibrating:CONDition?**  
**STATus:OPERation:CONDition?**  
**STATus:OPERation:LLFail:CONDition?**  
**STATus:OPERation:MEASuring:CONDition?**  
**STATus:OPERation:SENSe:CONDition?**  
**STATus:OPERation:TRIGger:CONDition?**  
**STATus:OPERation:ULFail:CONDition?**

**STATus:QUESTionable:CALibration:CONDition?**  
**STATus:QUESTionable:CONDition?**  
**STATus:QUESTionable:POWER:CONDition?**

These commands read out the `CONDition` section of the status register.

The commands do not delete the contents of the `CONDition` section.

**Usage:**                      Query only

### 10.11.3 Reading out the `EVENT` part

For more information on the `EVENT` part see [Chapter 9.2.2, "Structure of an SCPI status register"](#), on page 97.

---

**STATus:DEVIce[:EVENT]?**  
**STATus:OPERation:CALibrating[:SUMMARY][:EVENT]?**  
**STATus:OPERation[:EVENT]?**  
**STATus:OPERation:LLFail[:SUMMARY][:EVENT]?**  
**STATus:OPERation:MEASuring[:SUMMARY][:EVENT]?**  
**STATus:OPERation:SENSe[:SUMMARY][:EVENT]?**  
**STATus:OPERation:TRIGger[:SUMMARY][:EVENT]?**  
**STATus:OPERation:ULFail[:SUMMARY][:EVENT]?**  
**STATus:QUESTionable[:EVENT]?**  
**STATus:QUESTionable:CALibration[:SUMMARY][:EVENT]?**  
**STATus:QUESTionable:POWER[:SUMMARY][:EVENT]?**

These commands read out the `EVENT` section of the status register.

At the same time, the commands delete the contents of the `EVENT` section.

**Usage:**                      Query only

### 10.11.4 Controlling the `ENABLE` part

For more information on the `ENABLE` part see [Chapter 9.2.2, "Structure of an SCPI status register"](#), on page 97.

---

**STATus:DEVIce:ENABLE <value>**  
**STATus:OPERation:CALibrating:ENABLE <value>**  
**STATus:OPERation:ENABLE <value>**  
**STATus:OPERation:LLFail:ENABLE <value>**  
**STATus:OPERation:MEASuring:ENABLE <value>**

**STATus:OPERation:SENSe:ENABLE** <value>  
**STATus:OPERation:TRIGger:ENABLE** <value>  
**STATus:OPERation:ULFail:ENABLE** <value>  
**STATus:QUEStionable:CALibration:ENABLE** <value>  
**STATus:QUEStionable:ENABLE** <value>  
**STATus:QUEStionable:POWer:ENABLE** <value>

These commands control the **ENABLE** part of a register.

The **ENABLE** part allows true conditions in the **EVENT** part of the status register to be reported in the summary bit. If a bit is 1 in the enable register and its associated event bit transitions to true, a positive transition will occur in the summary bit reported to the next higher level.

**Parameters:**

<value>                      \*RST:              0

### 10.11.5 Controlling the negative transition part

For more information on the negative transition part see [Chapter 9.2.2, "Structure of an SCPI status register"](#), on page 97.

---

**STATus:DEvice:NTRansition** <value>  
**STATus:OPERation:CALibrating:NTRansition** <value>  
**STATus:OPERation:NTRansition** <value>  
**STATus:OPERation:LLFail:NTRansition** <value>  
**STATus:OPERation:MEASuring:NTRansition** <value>  
**STATus:OPERation:SENSe:NTRansition** <value>  
**STATus:OPERation:TRIGger:NTRansition** <value>  
**STATus:OPERation:ULFail:NTRansition** <value>  
**STATus:QUEStionable:CALibration:NTRansition** <value>  
**STATus:QUEStionable:NTRansition** <value>  
**STATus:QUEStionable:POWer:NTRansition** <value>

These commands control the Negative **TRansition** part of a register.

Setting a bit causes a 1 to 0 transition in the corresponding bit of the associated register. The transition also writes a 1 into the associated bit of the corresponding **EVENT** register.

**Parameters:**

<value>                      \*RST:              0

### 10.11.6 Controlling the positive transition part

For more information on the positive transition part see [Chapter 9.2.2, "Structure of an SCPI status register"](#), on page 97.

---

**STATus:DEvice:PTRansition** <value>  
**STATus:OPERation:CALibrating:PTRansition** <value>  
**STATus:OPERation:PTRansition** <value>  
**STATus:OPERation:LLFail:PTRansition** <value>  
**STATus:OPERation:MEASuring:PTRansition** <value>  
**STATus:OPERation:SENSe:PTRansition** <value>  
**STATus:OPERation:TRIGger:PTRansition** <value>  
**STATus:OPERation:ULFail:PTRansition** <value>  
**STATus:QUESTionable:CALibration:PTRansition** <value>  
**STATus:QUESTionable:PTRansition** <value>  
**STATus:QUESTionable:POWER:PTRansition** <value>

These commands control the Positive TRansition part of a register.

Setting a bit causes a 0 to 1 transition in the corresponding bit of the associated register. The transition also writes a 1 into the associated bit of the corresponding `EVENT` register.

**Parameters:**

<value>                      \*RST:              65535

## 10.12 Testing the R&S NRPM OTA Power Measurement Solution

The selftest allows a test of the internal circuitry of the sensor.

[TEST:SENSor?](#)..... 184

---

**TEST:SENSor?** [<Item>]

Triggers a selftest of the sensor module. In contrast to `*TST?`, this command returns detailed information that you can use for troubleshooting.

**Note:** Do not apply a signal while the selftest is running because it can indicate errors in the output messages for the test steps *Offset Voltages* and/or *Noise Voltages*.



## Calibrating/zeroing the R&amp;S NRPM3(N) sensor module

**Query parameters:**

&lt;Item&gt; String

**Usage:** Query only**Manual operation:** See "Selftest" on page 81

## 10.13 Calibrating/zeroing the R&S NRPM3(N) sensor module

Zeroing removes offset voltages from the analog circuitry of the sensor modules, so that there are only low powers displayed when there is no power applied. The zeroing process may take more than 8 seconds to complete.

We recommend that you zero in regular intervals (at least once a day), if :

- The temperature has varied by more than 5 K.
- The sensor module has been replaced.
- No zeroing was performed in the last 24 hours.
- Signals of very low power are to be measured, for instance, if the expected measured value is less than 10 dB above the lower measurement range limit.



Turn off all test signals before zeroing. An active test signal during zeroing causes an error.

Remote commands:

CALibration<1...4>:DATA.....	185
CALibration<1...4>:DATA:LENGTH?.....	186
CALibration<Channel>:ZERO:AUTO.....	186

---

### CALibration<1...4>:DATA <caldata>

Writes a binary calibration data set in the memory of the sensor module.

**Suffix:**

&lt;1...4&gt; 1...4

**Parameters:**

&lt;caldata&gt; &lt;block\_data&gt;

**CALibration<1...4>:DATA:LENGth?**

Queries the length in bytes of the calibration data set currently stored in the flash memory. Programs that read out the calibration data set can use this information to determine the capacity of the buffer memory required.

**Suffix:**

<1...4>                      1...4

**Usage:**

Query only

**CALibration<Channel>:ZERO:AUTO <state>**

Performs zeroing using the signal at the sensor module input.

Disconnect the sensor module from all power sources, since any signal at the RF input of the sensor module affects the calibration.

While zero calibration is in progress, no queries or other setting commands are allowed. Any communication attempt can run into a timeout.

The setting command accepts only the parameter `ONCE`; `OFF` and `ON` are ignored.

The query returns the value `ON` if a calibration is in progress, otherwise the value `OFF`.

**Suffix:**

<Channel>                      1...4

The channel suffix is ignored.

**Parameters:**

<state>                      \*RST:              OFF

**Manual operation:**      See "[Zero Calibration](#)" on page 75

# 11 Programming examples

This section provides programming examples for R&S NRPM OTA power measurement tasks. It includes examples for continuous average and trace power measurements in the common SCPI syntax.

In addition, Rohde & Schwarz provides archives with source code, project and auxiliary files, and programming examples under C/C++ and Python. The samples can be integrated into customer-specific applications.

The programming examples are part of the R&S NRP Toolkit, see [Chapter 4.5.3, "Optional software"](#), on page 22 and e.g. ["To install the R&S NRP Toolkit on MS Windows"](#) on page 24.

## 11.1 Performing a simple measurement

The simplest way to obtain a result is to use the following sequence of SCPI commands:

### Example:

```
*RST           // sets the continuous average mode and all parameters to default
INITiate      // initiates the measurement
FETCh?       // delivers measurement result to the output queue
```

When the measurement is complete, you can retrieve the result from the output queue.

## 11.2 Performing measurements in continuous average mode

This section describes programming examples for measuring continuous average power with one R&S NRPM. The examples demonstrate the sequences in SCPI syntax, pseudo code, and also show the corresponding source codes for using VISA protocol.

## Performing measurements in continuous average mode

**Example: SCPI sequence for measuring the power of three antenna modules**

The command sequence measures the continuous average power of the three channels of an R&S NRPM.

```
// Query the resource identifier and reset the sensor module to default
*IDN?
// Response: ROHDE&SCHWARZ,NRPM3,100001,16.09.20.01
*RST
// Enable all channels of the sensor module
SENSE:CHAnnel1:ENABle 1
SENSE:CHAnnel2:ENABle 1
SENSE:CHAnnel3:ENABle 1
// Select measurement mode and set the time interval to 10 µs
SENSE:FUNCTion "POWER:AVG"
SENSE:POWER:AVG:APERture 10e-6
//Set the averaging filter length to 1
SENSE:AVERAge:COUNT 1
// Select the trigger source
TRIGGer:SOURce IMMEDIATE
// Activate a measurement
INITiate:IMMEDIATE
// Query the measurement results
FETCh:ALL?
// Response:
// 6.118910E-10,1.185138E-10,4.612524E-10
// Read out all errors / Clear error queue
SYSTEM:ERRor?
SYSTEM:SERRor?
```

## Performing measurements in continuous average mode

**Example: Pseudo code for measuring the power of two antenna modules**

This example, written in pseudo code, shows a reduced set of basic steps to set up and execute a continuous average measurement.

```
// resource = "NRPM3-100001"
// Open the device
sensor = Open( resource )
// Query the resource identifier and reset the sensor module to default
Query( sensor, "*IDN?" )
Write( sensor, "*RST" )
// Measure only on channels 1 & 3
Write( sensor, "SENS:CHAN1:ENAB ON" )
Write( sensor, "SENS:CHAN2:ENAB OFF" )
Write( sensor, "SENS:CHAN3:ENAB ON" )
Write( sensor, "SENS:FUNC \"POW:AVG\"" )
Write( sensor, "TRIG:SOUR IMM" )
Query( sensor, "SYST:ERR?" )
Query( sensor, "SYST:SEERR?" )
Write( sensor, "INIT:IMM" )
Query( sensor, "FETCH:ALL?" )
Close( sensor )
```

**Example: C/C++ (VISA) source code**

This sequence shows the VISA source code, based on the *pseudo code* example above.

```
// Determine the resource identifier, e.g.
// resource = "NRPM3-100001"
// resource identifier = USB0::0x0aad::0x0195::100001
// Open the device
viOpen( defaultRM, "USB0::0x0aad::0x0195::100001", VI_NULL, VI_NULL, &session );
// Select the measurement mode
viWrite( session, "SENS:FUNC \"POW:AVG\"\n", 20, &uiSent );
// Initiate a single measurement
viWrite( session, "INIT:IMM\n", 9, &uiSent );
// Read the measurement result
viWrite( session, "FETCH:ALL?\n", 7, &uiSent );
viRead( session, buffer, sizeof(buffer), &uiCnt );
// buffer = "1.468872E-09,3.682521E-10,3.829144E-09"
// Close the device
viClose( session );
```

## Performing measurements in continuous average mode

**Example: Python (VISA) source code**

This sequence shows the Python source code, based on the *pseudo code* example above.

```
#####
## Name:          contAv-M3.py
## Purpose:       Measuring RF power with the R&S NRPM3 OTA sensor module
## Description:   This example demonstrates the use of an R&S NRPM3
##               sensor module measuring continuously average power
##               on up to 3 channels
## Author:        Juergen D. Geltinger
## Created:       2016-01-14
## Modified by:   Juergen D. Geltinger
## Modified:      2016-07-21
## Copyright:     (c) Rohde & Schwarz, Munich
#####

# This is a Visa sample, so import that module
import visa
from time import sleep
from math import fabs, log10

#####
# Find a R&S NRPM3 power sensor modules. That sensor module is
# characterized by a Product ID of 0x0195
#####
def OpenFirstNRPM3():
    rm = visa.ResourceManager()
    resources=list(rm.list_resources())
    for s in resources:
        # NRPM3 RF sensor module has a USB Product ID of '0x0195'
        if -1 != s.find("0195::"):
            print
            print "Opening NRPM3 sensor '" + s + "'..."
            sensor = rm.open_resource( s )
            if sensor != None:
                sensor.timeout = 20000
                # Setting Aperture Time
                sensor.write( "sens:pow:avg:aper 10e-6" )
                # Setting Average Filter Length
                sensor.write( "sens:aver:count 16" )
                print "Querying *IDN?..."
                print sensor.ask( "*idn?" )
                # Enable the available/connected antenna modules
                result = ""
                for antenna in range(3):
```

## Performing measurements in continuous average mode

```

cmd = "SENS:CHAN{}:PRES?".format( antenna + 1 )
res = sensor.ask(cmd)
if int(res) == 1:
    cmd = "SENS:CHAN{}:ENAB ON".format( antenna + 1 )
else:
    cmd = "SENS:CHAN{}:ENAB OFF".format( antenna + 1 )
    sensor.write(cmd)
print "SYST:ERR? --> " + sensor.ask("SYST:ERR?")
print "SYST:SERR? --> " + sensor.ask("SYST:SERR?")
return sensor
break
return None

#####
# Convert a power value of Watt unit to dBm unit
#####
def Watt2dBm( dW ):
    if fabs( dW ) < 1.0e-19:
        return -160.0
    return 10.0 * log10( fabs( dW ) ) + 30.0

#####
#####
#####
sensor = None
sensor = OpenFirstNRPM3()
if sensor != None:
    for meas in range(1,10):
        sensor.write("init:imm")
        result = sensor.ask("fetch:all?")
        antenna = [float(x) for x in result.split(",")]
        if antenna[0] < 9.9e37:
            print ('Antenna A = %4.1f dBm' % Watt2dBm( antenna[0] ) )
        if antenna[1] < 9.9e37:
            print ('Antenna B = %4.1f dBm' % Watt2dBm( antenna[1] ) )
        if antenna[2] < 9.9e37:
            print ('Antenna C = %4.1f dBm' % Watt2dBm( antenna[2] ) )
        print
    sensor.close()
else:
    print "No NRPM3 sensor found"

```

## 11.3 Performing measurements in list mode

This section briefly introduces the list mode operation, and describes a programming example for measuring average power sequentially at predefined RF frequency points with the R&S NRPM OTA Power Measurement Solution in list mode. The example represents the execution of a R&S NRPM OTA power sensor measurement under VISA environment in pseudo code.

### About list mode

The list mode enables you, to define a series of measurements at different frequency points in advance. The factors and values, that must be recalculated for each frequency point, are determined and saved internally before the measurement starts. Both, the R&S NRPM3(N) sensor module, and the DUT get the list of frequency points, and the R&S NRPM3(N) pre-calculates the corresponding parameters required for the measurement.

Synchronized by an initial RF pulse and a short delay time, the DUT and the R&S NRPM OTA power sensor measurement system perform the measurement for each frequency point automatically. They switch to the next frequency point controlled by a defined time interval.

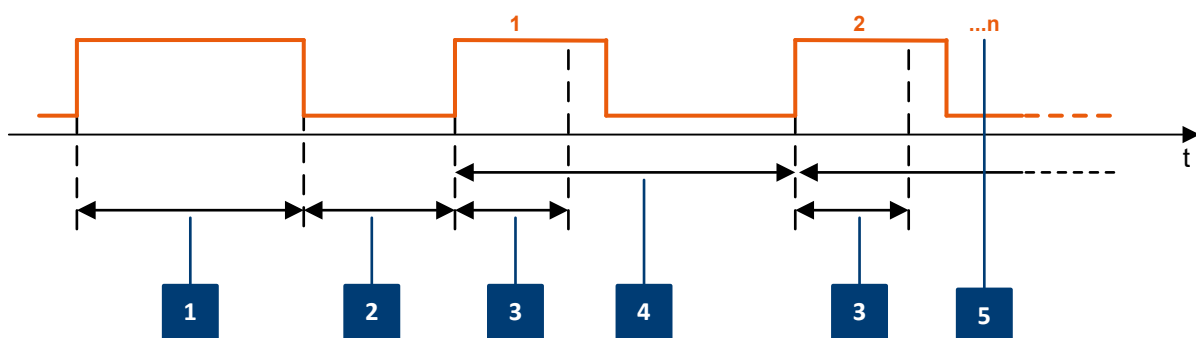

**Figure 11-1: Time scheme in list mode processing**

- 1 = Start burst
- 2 = Initial delay
- 3 = Single measurement time X
- 4 = Measurement period
- 5 = Frequency points n

### Related list mode parameters

- **Start burst** = RF pulse of at least 10  $\mu$ s minimum length, sent by the DUT
- **Initial delay** = time after the start burst until the measurement starts



## Performing measurements in list mode

- **Measurement period** = time from the beginning until the end of a step at one frequency point
- **n** = number of frequency points in the list
- **X** = actual time for a single measurement, calculated according to the formula:  
 $X = 2 * \text{AverageCount} * (\text{ApertureTime} + 100\mu\text{s})$
- **AverageCount** = number of averaged measurement readings
- **ApertureTime** = width of the sampling window

 **Aspects to consider**

- Minimum measurement time **220µs**  
The time span of the measurement pulse must not be below the minimum value, derived from:  
AverageCount (min) = 1, ApertureTime (min) = 10 µs:  
 $X = 2 * 1 * (10 \mu\text{s} + 100 \mu\text{s}) = 220 \mu\text{s}$   
Shorter pulses cannot be measured.
- The total number of pulses is summed up of the number of frequency points and the start burst.

## Performing measurements in list mode

**Example: Pseudo code for measuring the power in list mode**

This example, written in pseudo code, shows how to set up and execute a power measurement in list mode.

```
=====
Description of Receiver List Mode
=====
```

The execution of a configured frequency list shall start with an RF pulse sent by the DUT with a certain minimal length (= calling this 'start burst').

```

_____..._____
|                                     |
|<--- min. length of start burst --->|
_____|                               |_____...
```

After the FALLING edge of the start burst, the sensor will apply a configurable initial delay and then cycles over the configured frequency list, doing power measurements with pre-configured aperture windows and average counts. Each new measurement starts after a selectable measurement period.

```

_____<-initial delay->_____
| -start burst- | |<- X ->| |<- X ->| |
___| (see above) | _____| _____| _____|
                                     <-measurement period->
```

'X' is the time for a single measurement. It is calculated as follows:

$$X = 2 * \text{Average-Count} * (\text{ApertureTime} + 100\text{us})$$

```
*/
```

```

ViSession    session;
string       strCmd;
string       strRead;
unsigned int  uiAvgCount      = 2;           // 2
double       dAperture       = 100.0e-6;    // 100 us
double       dTriggerLevel   = 100.0e-9;    // 100 nW (= -40 dBm)
int          iTriggerAntenna = 1;           // Trigger-Burst re-
                                           // cognition on Ant 1
double       dMinLengthOfStartBurst = 950.0e-6; // 950 us
double       dInitialDelayAfterBurst = 1.0e-3; // 1 ms
```

## Performing measurements in list mode

```

double      dMeasurementPeriod      = 2.0e-3;    // 2 ms
double      arFreqList[]            = { 24.0e9, 24.5e9, 25.0e9,
                                         25.5e9, 26.0e9, 26.5e9,
                                         27.0e9, 27.5e9, 28.0e9 };

session = OpenfirstNRPM3onUSBorNetwork();

//=====
// *RST and *IDN?
WriteCmd(session, "*RST");
printf( Query(session, "*IDN?");

//=====
// Use only those antennas which are physically connected
for (size_t nAntenna = 0; nAntenna < 3; nAntenna++)
{
    strCmd = "SENS:CHAN" + str(1+nAntenna) + ":PRES?";
    strRead = Query(session, strCmd);
    if ( atoi(strRead) != 0 )
        strCmd = "SENS:CHAN" + str(1+nAntenna) + ":ENAB ON";
    else
        strCmd = "SENS:CHAN" + str(1+nAntenna) + ":ENAB OFF";

    WriteCmd(session, strCmd);
}

//=====
// Prepare Event Registers to recognize a finished measurement
//
// We want to detect the End of a Measurement;
// This is reflected by a negative transition of the
// 'Sensor Measuring' bit (bit value = 2)
WriteCmd(session, "STAT:OPER:MEAS:PTR 0");
WriteCmd(session, "STAT:OPER:MEAS:NTR 2");
WriteCmd(session, "STAT:OPER:MEAS:ENAB 2");

// We want to detect the MEAS summary bit (as a
// results of the finished measurement as defined
// above). This is reflected by a positive transition
// 'MEAS summary' bit in the Operation Status Register
// (bit value = 16)
WriteCmd(session, "STAT:OPER:PTR 16");
WriteCmd(session, "STAT:OPER:NTR 0");

```

## Performing measurements in list mode

```

WriteCmd(session, "STAT:OPER:ENAB 16");

//=====
// Setup the Measurement...
//
// Configure Averaging
strCmd = "SENS:AVER:COUNT " + str(uiAvgCount);
WriteCmd(session, strCmd);
WriteCmd(session, "SENS:AVER:STAT ON");

// Aperture time
strCmd = "SENS:POW:AVG:APER " + str(dAperture);
WriteCmd(session, strCmd);

// Prepare the triggering of the measurement start
// (= start of execution of the configured freq. list)
//
// The execution of the configured frequency list shall
// start with an RF pulse from the DUT with a certain
// minimal length (here 950 us). The sensor setting
// 'trigger dropout' time is used to recognize this,
// and the execution shall start after the FALLING edge
// of this initial 'start burst':
//
//      _____..._____
//      |                                     |
//      |<--- min. length of start burst --->|
//      _____|                             |_____...
//
//
// Trigger on falling edge (= neg. slope)
WriteCmd(session, "TRIG:SLOP NEG");

// Minimal length of start burst (= Trigger Dropout)
strCmd = "TRIG:DTIM " + str(dMinLengthOfStartBurst);
WriteCmd(session, strCmd);

// Trigger on the signal level on a selected antenna
strCmd = "TRIG:SOUR BURST " + str(iTriggerAntenna);
WriteCmd(session, strCmd);

// Trigger Level
strCmd = "TRIG:LEV " + str(dTriggerLevel);
WriteCmd(session, strCmd);

```

## Performing measurements in list mode

```

// After the initial start pulse a continuous sequence of
// measurements are executed. The number of measurements is
// selected by the length of the frequency list -- see entries
// in 'arFreqList[]' above (here 9)
//
// There very first measurement starts after a short initial delay
// (= 'trigger burst delay') to give the DUT time to setup/prepare
// its sending of the planned frequencies
//
// _____
// |               | <-initial delay-> |       | |       | |       |
// | -start burst- |                   |<-X->| |       |<-X->| |
// __| (see above) |_____..._____ |       |____...__|       |____...
//
//                                     <- meas. period ->
//                                     (= trigger holdoff)
//
// 'X' is the Time for a single measurement. 'X' shall be shorter than
// the receiving pulse from the DUT.
//
// X = 2 * Average-Count * (ApertureTime + 100us)
//

// Initial delay before the very first measurement
// (= 'trigger burst delay')
strCmd = "TRIG:BURS:DEL " + str(dInitialDelayAfterBurst);
WriteCmd(session, strCmd);

// The measurement period is timed by the 'trigger holdoff' parameter
// This is simply the distance from one measurement start to the next
strCmd = "TRIG:HOLD " + str(dMeasurementPeriod);
WriteCmd(session, strCmd);

// Freq List
strCmd = "SENS:LIST:FREQ ";
strCmd += ConvertListToString(arFreqList, 9);
WriteCmd(session, strCmd);

WriteCmd(session, "CONT:FREQ:MODE RXLIST");

// Desired Result Data Format (here ASCII)
WriteCmd(session, "FORM:DATA ASC");

// Check for any setting errors

```

## Performing measurements in list mode

```

print(Query(session, "SYST:ERR?"));

// Check for static errors
print(Query(session, "SYST:SERR?"));

//=====
// Execute the list mode measurement
//
// resetting the event information by an initial readout
Query(session, "STAT:OPER:MEAS:EVEN?");
Query(session, "STAT:OPER:EVEN?");

// Start a measurement
WriteCmd(session, "INIT:IMM");

// Synchronize with end of measurement...
// (We will prematurely end this function if we do not get a trigger
// within approx. 30 seconds)
bool bMeasReady = FALSE;
unsigned int uiSleep = 10; // 10 ms
unsigned int uiWaitForTriggerTimeoutCount = 5000 / uiSleep;
unsigned short usEvent = 0;
while (!bMeasReady)
{
    Query(pSensor->session, "STAT:OPER:MEAS:EVEN?", szReadBuff,
        sizeof(szReadBuff));
    usEvent = atoi(Query(session, "STAT:OPER:MEAS:EVEN?"));
    bMeasReady = ((usEvent & 0x02) != 0);
    if (bMeasReady)
        break;

    if (uiWaitForTriggerTimeoutCount > 0)
    {
        --uiWaitForTriggerTimeoutCount;
        _sleep(10);
    }
    else
        break;
}

// If no trigger burst has been recognized, we prematurely end here!
if (!bMeasReady)
    return 0; // No results

// Fetch AVERAGE results

```

## Performing measurements in trace mode

```
WriteCmd(session, "CALC:FEED \"POW:AVER\");  
strRead = Query(session, "FETCH:ALL?");  
  
print( strRead );    // all measurement results  
  
close(session);
```

## 11.4 Performing measurements in trace mode

This section describes programming examples for measuring power over time with the R&S NRPM OTA Power Measurement Solution. The examples demonstrate the sequences in SCPI syntax, pseudo code, and also show the source codes for using VISA protocol.

## Performing measurements in trace mode

**Example: SCPI sequence for measuring the power of three antenna modules**

The command sequence measures the envelope power over time in the three channels of the R&S NRPM antenna module.

```
// Query the resource identifier and
// reset the sensor module to default
*IDN?
// Response: ROHDE&SCHWARZ,NRPM3,100001,16.09.20.01
*RST
// Enable all channels of the sensor module
SENSE:CHAnnel1:ENABle 1
SENSE:CHAnnel2:ENABle 1
SENSE:CHAnnel3:ENABle 1
// Set the trace measurement mode
SENSE:FUNCTion "XTIME:POWer"
// Set the trace time.It influences the time length of a point
// since each point represents the time period resulting from
// the trace time divided by the number of points
SENSE:TRACe:TIME 10e-3
// Set the number of points for the trace measurement
// Using 500 points usually represents a good compromise
// between USB transfer speed and resolution
SENSE:TRACe:POINTs 10
// Enable and configure the averaging filter
SENSE:TRACe:AVERAge:COUNT 8
SENSE:TRACe:AVERAge:STATe ON
// Configure the trigger
TRIGGer:SOURce INTernal
TRIGGer:SLOPe POSitive
TRIGGer:DTIME 0.001
TRIGGer:HYSTEResis 0.1
TRIGGer:LEVel 100e-9
// Activate the measurement
INITiate
// Query the measurement results
FETCh:ALL?
// Response (10 points per channel):
// 1.247340E-07,9.701300E-11,1.249202E-07,1.255408E-10,1.248314E-07,
// 9.718711E-11,1.248812E-07,6.739847E-11,1.248604E-07,2.118106E-10,
// 1.644239E-09,4.748356E-11,1.676801E-09,6.181332E-12,1.670082E-09,
// -1.933849E-11,1.719137E-09,-4.777736E-12,1.678197E-09,3.814278E-12,
// -4.753650E-11,-7.962022E-12,-4.782197E-11,-3.001128E-11,-8.387346E-12,
// -5.910127E-11,5.714555E-11,-5.767460E-12,7.732340E-11,-1.816896E-11
// Read out all errors / Clear error queue
SYSTEM:ERRor?
```



## Performing measurements in trace mode

```
SYSTem:SERRor?  
// Stop the continuous measurement.  
INITiate:CONTInuous OFF
```

**Example: Pseudo code for measuring the power of two antenna modules**

This example, written in pseudo code, shows how to set up and execute a trace power measurement.

```
// resource = "NRPM3-100001"  
// Open the device  
sensor = Open( resource )  
// Query the resource identifier and reset the sensor module to default  
Query( sensor, "*IDN?" )  
Write( sensor, "*RST" )  
// Measure only on channels 1 & 3  
Write( sensor, "SENS:CHAN1:ENAB ON" )  
Write( sensor, "SENS:CHAN2:ENAB OFF" )  
Write( sensor, "SENS:CHAN3:ENAB ON" )  
Write( sensor, "SENS:FUNC \"XTIM:POW\"" )  
Write( sensor, "TRIG:SOUR IMM" )  
Query( sensor, "SYST:ERR?" )  
Query( sensor, "SYST:SERR?" )  
Write( sensor, "INIT:IMM" )  
Query( sensor, "FETCH:ALL?" )  
Close( sensor )
```

## Performing measurements in trace mode

**Example: C/C++ (VISA) source code**

This sequence shows the VISA source code, based on the *pseudo code* example above.

```
// Determine the resource identifier, e.g.
// resource = "NRPM3-100001"
// resource identifier = USB0::0x0aad::0x0195::100001
// Open the device
viOpen( defaultRM, "USB0::0x0aad::0x0195::100001", VI_NULL, VI_NULL, &session );
// Select the trace measurement mode
viWrite( session, "SENS:FUNC \"XTIM:POW\"\n", 21, &uiSent );
// Set the overall length (10 ms) of the trace
// select the number of measurement points (500 points)
viWrite( session, "SENS:TRAC:TIME 10.0e-3\n", 23, &uiSent );
viWrite( session, "SENS:TRAC:POINTS 500\n", 21, &uiSent );
// Initiate a single measurement
viWrite( session, "INIT:IMM\n", 9, &uiSent );
// Read the measurement result
viWrite( session, "FETCH1?\n", 7, &uiSent );
viRead( session, resA, sizeof(resA), &uiCnt );
viWrite( session, "FETCH2?\n", 7, &uiSent );
viRead( session, resB, sizeof(resB), &uiCnt );
viWrite( session, "FETCH3?\n", 7, &uiSent );
viRead( session, resC, sizeof(resC), &uiCnt );
// process resA, resB and resC. Every buffer contains
// the measurement data of one channel
// Close the device
viClose( session );
```

# 12 Troubleshooting

- [Displaying status information](#)..... 203
- [Performing a selftest](#)..... 203
- [Problems during a firmware update](#)..... 204
- [Cannot establish a LAN connection](#)..... 205
- [Replacing antenna cables](#)..... 206
- [Contacting customer support](#)..... 210

## 12.1 Displaying status information

Status information is available in several ways.

### Status LED of the R&S NRPM

The position of the status LED is indicated in [Chapter 5, "R&S NRPM tour"](#), on page 29.

The meaning of the different colors and blinking frequencies is explained in "[Status LED \(2\)](#)" on page 30.

### Title bar of the web browser-based user interface (R&S NRPM3N LAN sensor module)

 Requires a sensor module with networking capabilities, a R&S NRPM3N sensor module.

The position of the status icon is indicated in [Figure 7-1](#). The colors are explained in "[Status LED \(2\)](#)" on page 30.

## 12.2 Performing a selftest

The selftest gives you detailed information that you can use for troubleshooting.

## Problems during a firmware update

-  Do not apply a signal to the sensor module while the selftest is running. Executing the self-test with an active signal assigned, can erroneously result in error messages at the test steps *Offset Voltages* and/or *Noise Voltages*.

**To execute the selftest over remote control**

- ▶ For a quick check, send `TEST:SENSoR?`.  
For each test step, PASS or FAIL is listed.

**To execute the self test in the web browser-based user interface (R&S NRPM3N LAN sensor module)**

1. In the navigation pane of the main dialog, select "Sensor".
2. Under "Diagnostics", select "Selftest".  
See also "[Selftest](#)" on page 81.

## 12.3 Problems during a firmware update

The firmware update is described in [Chapter 8, "Firmware update"](#), on page 83.

Solutions for potential problems that can occur when using the firmware update for R&S NRP family, see "[Firmware update for R&S NRP family](#)" on page 84.

**Firmware update was interrupted**

If, for example, a power cut happened during the firmware update, problems can occur.

1. Perform the firmware update again. Sometimes, a further update fixes the problems.
2. If you nevertheless can not access the sensor module, contact the local service representative.

### Firmware update was aborted

If there is not enough free memory space, the firmware update aborts. An error message is displayed, and the status LED of the sensor module starts flashing red.

1. Execute the sanitization procedure, as described in the instrument security procedures. You find this document on the product page at: [www.rohde-schwarz.com/manual/nrpm](http://www.rohde-schwarz.com/manual/nrpm).
2. Start the firmware update again.

## 12.4 Cannot establish a LAN connection

If you have problems to establish a LAN connection as described in [Chapter 6.3.4, "Using the LAN connection"](#), on page 50, try the following measures:

- Use the *Configure Network Sensor* component of the R&S NRP Toolkit, see [Chapter 12.4.1, "Components of the R&S NRP Toolkit"](#), on page 205.
- ["Troubleshooting for peer-to-peer connections"](#) on page 54.

### 12.4.1 Components of the R&S NRP Toolkit

Access:

- ▶ "Start" > "NRP-Toolkit"

The following tools are part of the R&S NRP Toolkit for Windows.

#### Configure network sensor

Useful if you have troubles establishing a LAN connection with an R&S NRPM3N LAN sensor module. The tool provides the following functions:

- Configuring the network settings by (temporarily) connecting the selected sensor to the computer using USB.
- Discovering the sensors that have been configured via the Zeroconf (APIA) protocol.

The tool comes with a guide (PDF) that is also available in the "Start" menu. The guide explains the network setup.

**Firmware update**

You can use the firmware update for R&S NRP family program to load new firmware for the sensor modules, see [Chapter 8.2.1, "Using the firmware update for R&S NRP family program"](#), on page 84.

**NRP version display**

Displays version information of all installed, power measurement-relevant software packages.

**NRP uncertainty calculator**

Determines the expanded measurement uncertainty. The tool comes with a manual (PDF) that is also available in the "Start" menu.

**S-Parameter update multi**

 S-parameter compensation is not supported by the R&S NRPM3 sensor modules.

**Terminal**

Low-level communication program for sending commands to the sensor module.

## 12.5 Replacing antenna cables

### 12.5.1 Spare parts and recommended tools

The available cable replacement kits are listed in the table that follows:

Description	Part no.	Applicable for A90	Applicable for A90D
Cable replacement Kit, 550 mm	1436.2855.02	yes	yes
Cable replacement Kit, 750 mm	1436.2855.03	yes	yes
Cable replacement Kit, 1000 mm	1436.2855.04	yes	yes
Cable replacement Kit, 1500 mm	1436.2855.05	yes	yes

The recommended tools are listed in the table that follows:

Tool	Description, part no.
Screwdriver, flat tip Blade width 3 mm max.	Commercial off the shelf <b>Example:</b> WERA Werk Hermann Werner GmbH & Co. KG 160 i VDE insulated screwdriver for slotted screws Part no. 05006100001 <a href="http://www.wera.de">www.wera.de</a>
Cable tie tool (Force: 50 N ± 5 N)	Commercial off the shelf <b>Example:</b> PANDUIT® GS2B tension Part no.: GSB2 <a href="http://www.panduit.com">www.panduit.com</a>
Electronics side cutter	Commercial off the shelf <b>Example:</b> KNIPEX-Werk C. Gustav Putsch KG Electronic Super Knips® Part no. 78 71 125 <a href="http://www.knipex.com">www.knipex.com</a>

## 12.5.2 Cable replacement

- 
  - There are two versions of the strain relief. The old version is shown on the left hand side of the figures. The new version is shown on the right hand side of the figures.
  - The procedure of cable replacement is shown for the single variant of the strain relief. The procedure is also applicable for the dual variant of the strain relief.

### To change the antenna cable

1. Remove the cable tie.  
Use the electronics side cutter (part no. 78 71 125 or equivalent).

## Replacing antenna cables

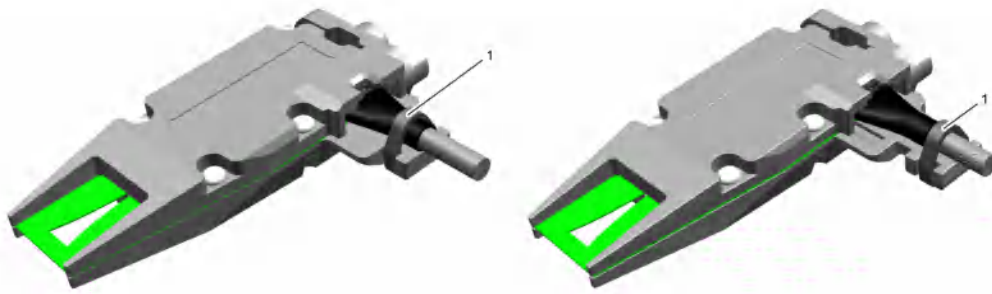

*Figure 12-1: Removing cable tie*

2. Hold the locking lug down to unlock the cable.  
Use the flat tip screwdriver (part no. 05006100001 or equivalent).

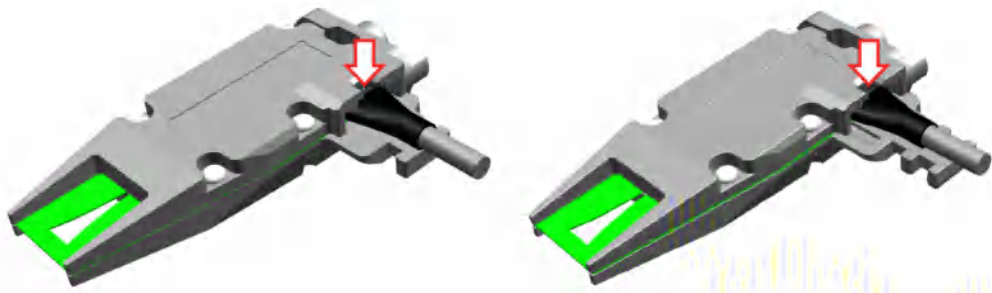

*Figure 12-2: Unlocking cable*

3. **NOTICE!** Remove the cable in a linear movement to prevent damage.  
While you hold down the locking lug, remove the cable.
4. Place the new cable in the notch.

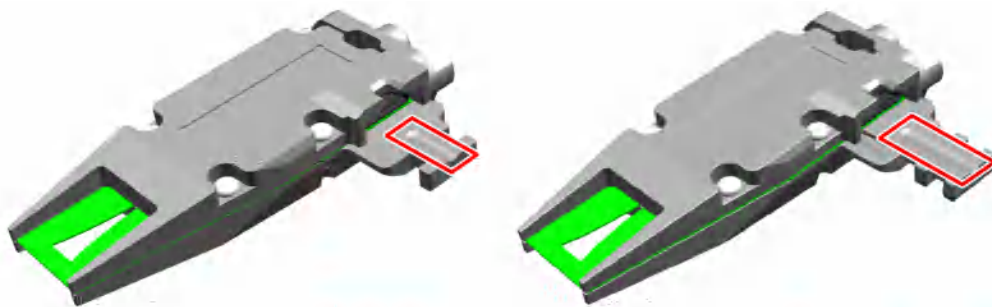

*Figure 12-3: Placing the new cable*

5. **NOTICE!** Connect the new cable in a linear movement to prevent damage.  
Connect the new cable until it snaps in.



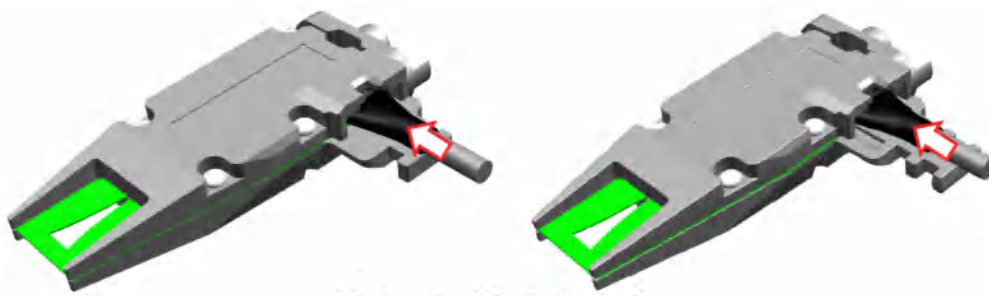

*Figure 12-4: Connect new cable*

6. **NOTICE!** Monitor the position of the cable tie head.  
Place the cable tie. Use the notch to place the cable tie correctly.

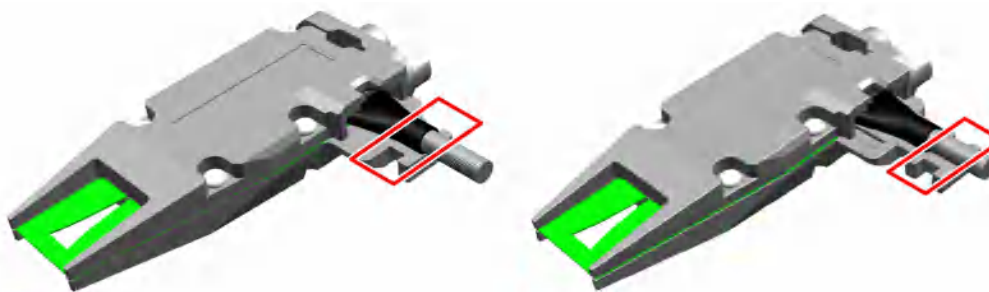

*Figure 12-5: Placing a cable tie*

7. **NOTICE!** Risk of damage of the cable and the connector. Make sure that the force of the automatic cable tie gun is set correctly to prevent cable damage. Make sure that the cable is free of load.  
Fasten the cable tie.  
Use the cable tie tool (part no. GSB2 or equivalent). Set the force of the cable tie tool to 50 N  $\pm$  5 N.

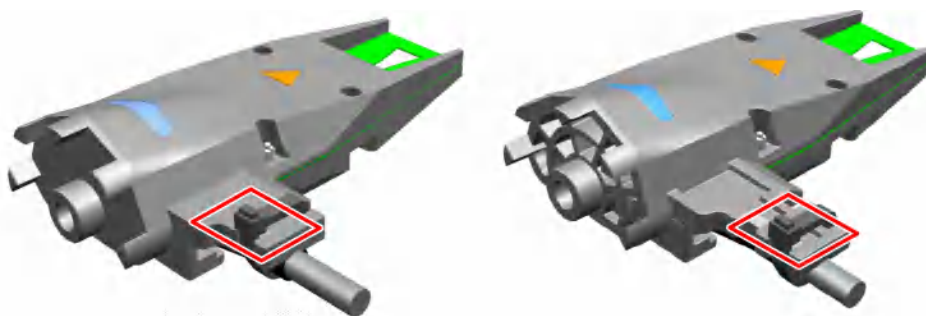

*Figure 12-6: Position of the cable tie head*

8. Cut off the protruding cable tie.  
Use the electronics side cutter (part no. 78 71 125 or equivalent).

9. **NOTICE!** We recommend that you execute a selftest after replacing the cables and reassembling the system.

Execute a selftest with the command:

`TEST:SENSor?` on page 184

10. Check the selftest for passed or failed, using the command:

`TEST:SENSor??`

## 12.6 Contacting customer support

### Technical support – where and when you need it

For quick, expert help with any Rohde & Schwarz product, contact our customer support center. A team of highly qualified engineers provides support and works with you to find a solution to your query on any aspect of the operation, programming or applications of Rohde & Schwarz products.

### Contact information

Contact our customer support center at [www.rohde-schwarz.com/support](http://www.rohde-schwarz.com/support), or follow this QR code:



*Figure 12-7: QR code to the Rohde & Schwarz support page*

# 13 Transporting

## **Packing**

Use the original packaging material. It consists of antistatic wrap for electrostatic protection and packing material designed for the product.

If you do not have the original packaging, use similar materials that provide the same level of protection.

## **Securing**

When moving the product in a vehicle or using transporting equipment, make sure that the product is properly secured. Only use items intended for securing objects.

## **Transport altitude**

Unless otherwise specified in the data sheet, the maximum transport altitude without pressure compensation is 4500 m above sea level.

# 14 Maintenance, storage and disposal

The product does not require regular maintenance. It only requires occasional cleaning. It is however advisable to check the nominal data from time to time.

## 14.1 Cleaning

### To clean the R&S NRPM3(N) sensor module

1. Disconnect the sensor module from the antenna modules.
2. Disconnect the sensor module from the controller PC.
3. Clean the outside of the R&S NRPM3(N) sensor module using a lint-free cloth. You can dampen the cloth with water but keep in mind that the casing is not waterproof. If you use isopropyl alcohol or ethanol instead of water, be careful not to damage the labeling.  
Do not use cleaning agents that can damage the instrument such as solvents, acids or alkalis.
4. To dislodge any particels from the antenna interface connector, use clean compressed air.

### To clean the antenna modules

- ▶ To dislodge any particels from the waveguide of an antenna module, use clean compressed air only.  
Do not use any liquids for cleaning.

## 14.2 Storage

Put plastic end caps on the RF connectors to protect them from damage. Protect the sensor module against dust.

Ensure that the environmental conditions, e.g. temperature range and climatic load, meet the values specified in the data sheet.

Always store the antenna modules in the original package to avoid mechanical damage.

## 14.3 Disposal

Rohde & Schwarz is committed to making careful, ecologically sound use of natural resources and minimizing the environmental footprint of our products. Help us by disposing of waste in a way that causes minimum environmental impact.

### Disposing electrical and electronic equipment

A product that is labeled as follows cannot be disposed of in normal household waste after it has come to the end of its service life. Even disposal via the municipal collection points for waste electrical and electronic equipment is not permitted.



**Figure 14-1: Labeling in line with EU directive WEEE**

Rohde & Schwarz has developed a disposal concept for the eco-friendly disposal or recycling of waste material. As a manufacturer, Rohde & Schwarz completely fulfills its obligation to take back and dispose of electrical and electronic waste. Contact your local service representative to dispose of the product.

# Glossary: List of used terms and abbreviations

## A

**anechoic chamber:** Non-reflective, non-echoing box ([RF shielded box](#)) or chamber ([RF test chamber](#)) that absorbs reflections of radio frequencies, used to test antennas, radars or electromagnetic interference.

**API:** Application Programming Interface

**Average count:** Number of averaged readings

**Average factor:** see [Average count](#)

## B

**Beamforming:** Steering a beam in the direction of the receiver.

## C

**Computer name:** An unambiguous indication of the instrument in a LAN that uses a DNS server.

The default computer name follows the syntax `NRPM3-<serial number>`, e.g. `NRPM3-100099`.

Synonym: [Hostname](#)

See Serial number.

**CW:** Continuous Wave

## D

**DUT:** Device Under Test

## E

**EIRP:** Equivalent Isotropically Radiated Power

**Ethernet:** Linking technology to connect computers and electronic devices in wired local area networks ([LANs](#)).

**G**

**Glossary:** List of the often used terms and abbreviations

**GUI:** Graphical User Interface

**H**

**Hostname:** [Computer name](#)

**L**

**LAN:** Local Area Network. A network that connects computers and electrical devices within a small area.

**O**

**OS:** Operating System

**OTA:** Over The Air

**P**

**PC:** Personal Computer, desktop or laptop PC

**PoE:** Power over Ethernet: Technology for local area networks (LAN) that provides the electrical power for a device over the Ethernet cable.

**Power:** A term describing the signal level in the RF domain or defining the length of the I/Q vector in the Baseband domain.

**product page:** A designation of the R&S NRPM product page.

**R**

**R&S NRP-Toolkit:** Software package, which provides drivers for Linux, Mac OS X or MS Windows.

**Remote control:** The operation of the R&S NRPM by remote control commands or programs to perform automated tests. The instrument is connected to a system controller via LAN/VXI-11, GPIB or USB using Virtual Instrument Software Architecture (VISA). The instrument is controlled either directly, or supported by instrument drivers.

**RF:** Radio Frequency

**RF shielded box:** Anechoic test box with very low reflectivity. Provides a shielded test environment for OTA measurements of radio frequencies.

**RF test chamber:** Larger anechoic RF test chamber up to RF test room sizes with very low reflectivity. Provides a shielded test environment for OTA measurements of radio frequencies.

**rsu:** Rohde & Schwarz Update. A file format which contains updated device software. Processed by a firmware update program.

## S

**Shielded box:** See [anechoic chamber](#).

**Shielded cube:** See [anechoic chamber](#).

## T

**Trigger:** Internally generated or externally supplied signal which starts signal generation at a particular point in time.

**Trigger event:** A trigger event is caused by the received trigger signal or executed manual trigger.

## U

**USB:** Universal Serial Bus. A standard type of connection for many different kinds of devices.

**USBTMC:** (USB Test & Measurement Class)

A protocol built on top of USB for communication with USB devices. Using VISA library, it supports service request, triggers, and other specific operations, similar to GPIB.

## V

**VISA:** Virtual Instrument Software Architecture

A standardized software interface library providing input and output functions to communicate with instruments.

## W

**WPTC:** (Wireless Performance Test Chamber)



Anechoic chamber with very low reflectivity. Provides a shielded test environment for OTA measurements of radio frequencies.

# List of commands

[SENSe<Sensor>:][POWer:][AVG:]APERture.....	154
[SENSe<Sensor>:][POWer:][AVG:]BUFFer:CLEar.....	154
[SENSe<Sensor>:][POWer:][AVG:]BUFFer:COUNT?.....	155
[SENSe<Sensor>:][POWer:][AVG:]BUFFer:DATA?.....	155
[SENSe<Sensor>:][POWer:][AVG:]BUFFer:INFO?.....	155
[SENSe<Sensor>:][POWer:][AVG:]BUFFer:SIZE.....	155
[SENSe<Sensor>:][POWer:][AVG:]BUFFer:STATe.....	156
[SENSe<Sensor>:][POWer:][AVG:]SMOothing:STATe.....	156
[SENSe<Sensor>:]AUXiliary.....	152
[SENSe<Sensor>:]AVERAge:COUNT.....	166
[SENSe<Sensor>:]AVERAge:RESet.....	166
[SENSe<Sensor>:]AVERAge:TCONtrol.....	167
[SENSe<Sensor>:]AVERAge[:STATe].....	167
[SENSe<Sensor>:]CHANnel<Channel>:PRESEnce?.....	134
[SENSe<Sensor>:]CHANnel<Channel>[:ENABLE].....	134
[SENSe<Sensor>:]CORRection:DCYClE.....	169
[SENSe<Sensor>:]CORRection:DCYClE:STATe.....	169
[SENSe<Sensor>:]CORRection:OFFSet.....	170
[SENSe<Sensor>:]CORRection:OFFSet:STATe.....	170
[SENSe<Sensor>:]FREQuency.....	168
[SENSe<Sensor>:]FUNctIon.....	149
[SENSe<Sensor>:]LIST:FREQuency.....	157
[SENSe<Sensor>:]LIST:FREQuency:POINts?.....	157
[SENSe<Sensor>:]ROSCillator:SOURce.....	135
[SENSe<Sensor>:]TRACe:AVERAge:COUNT.....	158
[SENSe<Sensor>:]TRACe:AVERAge:TCONtrol.....	158
[SENSe<Sensor>:]TRACe:AVERAge[:STATe].....	159
[SENSe<Sensor>:]TRACe:DATA?.....	159
[SENSe<Sensor>:]TRACe:MPWidth?.....	163
[SENSe<Sensor>:]TRACe:OFFSet:TIME.....	163
[SENSe<Sensor>:]TRACe:POINts.....	163
[SENSe<Sensor>:]TRACe:REALtime.....	163
[SENSe<Sensor>:]TRACe:TIME.....	164
[SENSe<Sensor>:]TRACe:UPSample[:TYPE].....	164
*CLS.....	115
*ESE.....	115
*ESR?.....	116
*IDN?.....	116

*IST?	116
*OPC	116
*OPT?	117
*PRE	117
*RCL	117
*RST	118
*SAV	118
*SRE	118
*STB?	118
*TRG	119
*TST?	119
*WAI	119
ABORt	171
CALCulate:FEED	150
CALCulate:MATH[:EXPRession]	151
CALCulate:MATH[:EXPRession]:CATalog?	152
CALibration<1...4>:DATA	185
CALibration<1...4>:DATA:LENGth?	186
CALibration<Channel>:ZERO:AUTO	186
CONTRol<Sensor>:FREQUency:MODE	157
FETCh<Channel>[:SCALAR][:POWER][:AVG]?	150
FETCh<Sensor>:ALL[:SCALAR][:POWER][:AVG]?	150
FORMat:BORDER	136
FORMat:SREGister	136
FORMat[:DATA]	137
INITiate:ALL	171
INITiate:CONTInuous	172
INITiate[:IMMediate]	171
STATus:DEVIce:CONDition?	181
STATus:DEVIce:ENABLE	182
STATus:DEVIce:NTRansition	183
STATus:DEVIce:PTRansition	184
STATus:DEVIce[:EVENT]?	182
STATus:OPERation:CALibrating:CONDition?	181
STATus:OPERation:CALibrating:ENABLE	182
STATus:OPERation:CALibrating:NTRansition	183
STATus:OPERation:CALibrating:PTRansition	184
STATus:OPERation:CALibrating[:SUMMery][:EVENT]?	182
STATus:OPERation:CONDition?	181
STATus:OPERation:ENABLE	182
STATus:OPERation:LLFail:CONDition?	181

STATus:OPERation:LLFail:ENABLE.....	182
STATus:OPERation:LLFail:NTRansition.....	183
STATus:OPERation:LLFail:PTRansition.....	184
STATus:OPERation:LLFail[:SUMMARY][:EVENT]?	182
STATus:OPERation:MEASuring:CONDition?.....	181
STATus:OPERation:MEASuring:ENABLE.....	182
STATus:OPERation:MEASuring:NTRansition.....	183
STATus:OPERation:MEASuring:PTRansition.....	184
STATus:OPERation:MEASuring[:SUMMARY][:EVENT]?	182
STATus:OPERation:NTRansition.....	183
STATus:OPERation:PTRansition.....	184
STATus:OPERation:SENSe:CONDition?.....	181
STATus:OPERation:SENSe:ENABLE.....	183
STATus:OPERation:SENSe:NTRansition.....	183
STATus:OPERation:SENSe:PTRansition.....	184
STATus:OPERation:SENSe[:SUMMARY][:EVENT]?	182
STATus:OPERation:TRIGger:CONDition?.....	181
STATus:OPERation:TRIGger:ENABLE.....	183
STATus:OPERation:TRIGger:NTRansition.....	183
STATus:OPERation:TRIGger:PTRansition.....	184
STATus:OPERation:TRIGger[:SUMMARY][:EVENT]?	182
STATus:OPERation:ULFail:CONDition?.....	181
STATus:OPERation:ULFail:ENABLE.....	183
STATus:OPERation:ULFail:NTRansition.....	183
STATus:OPERation:ULFail:PTRansition.....	184
STATus:OPERation:ULFail[:SUMMARY][:EVENT]?	182
STATus:OPERation[:EVENT]?	182
STATus:PRESet.....	181
STATus:QUEStionable:CALibration:CONDition?.....	182
STATus:QUEStionable:CALibration:ENABLE.....	183
STATus:QUEStionable:CALibration:NTRansition.....	183
STATus:QUEStionable:CALibration:PTRansition.....	184
STATus:QUEStionable:CALibration[:SUMMARY][:EVENT]?	182
STATus:QUEStionable:CONDition?.....	182
STATus:QUEStionable:ENABLE.....	183
STATus:QUEStionable:NTRansition.....	183
STATus:QUEStionable:POWer:CONDition?.....	182
STATus:QUEStionable:POWer:ENABLE.....	183
STATus:QUEStionable:POWer:NTRansition.....	183
STATus:QUEStionable:POWer:PTRansition.....	184
STATus:QUEStionable:POWer[:SUMMARY][:EVENT]?	182

STATus:QUEStionable:PTRansition.....	184
STATus:QUEStionable[:EVENT]?.....	182
STATus:QUEue[:NEXT]?.....	181
SYSTem:COMMunicate:NETWork:IPADdress.....	121
SYSTem:COMMunicate:NETWork:IPADdress:GATeway.....	121
SYSTem:COMMunicate:NETWork:IPADdress:INFO?.....	122
SYSTem:COMMunicate:NETWork:IPADdress:MODE.....	122
SYSTem:COMMunicate:NETWork:IPADdress:SUBNet:MASK.....	122
SYSTem:COMMunicate:NETWork:RESet.....	123
SYSTem:COMMunicate:NETWork:REStart.....	123
SYSTem:COMMunicate:NETWork:STATus?.....	123
SYSTem:COMMunicate:NETWork[:COMMOn]:DOMain.....	124
SYSTem:COMMunicate:NETWork[:COMMOn]:HOSTname.....	124
SYSTem:DFPPrint<Channel>?.....	124
SYSTem:ERRor:ALL?.....	124
SYSTem:ERRor:CODE:ALL?.....	125
SYSTem:ERRor:CODE[:NEXT]?.....	125
SYSTem:ERRor:COUNT?.....	125
SYSTem:ERRor[:NEXT]?.....	126
SYSTem:FWUPdate.....	126
SYSTem:FWUPdate:STATus?.....	127
SYSTem:HELP:HEADers?.....	128
SYSTem:HELP:SYNTax:ALL?.....	128
SYSTem:HELP:SYNTax?.....	128
SYSTem:INFO?.....	128
SYSTem:INITialize.....	129
SYSTem:LANGuage.....	129
SYSTem:LED:CHANnel<Channel>:COLor.....	130
SYSTem:LED:COLor.....	130
SYSTem:LED:MODE.....	131
SYSTem:MINPower?.....	131
SYSTem:PARAmeters:DELTA?.....	131
SYSTem:PARAmeters?.....	131
SYSTem:PRESet.....	131
SYSTem:REBoot.....	132
SYSTem:REStart.....	132
SYSTem:SERRor:LIST:ALL?.....	132
SYSTem:SERRor:LIST[:NEXT]?.....	132
SYSTem:SERRor?.....	133
SYSTem:TLEVels?.....	133
SYSTem:TRANsaction:BEgin.....	133

SYSTem:TRANSACTION:END.....	133
SYSTem:VERSion?.....	133
SYSTem[:SENSor]:NAME.....	134
TEST:SENSor?.....	184
TRIGger:ATRigger:DElay.....	173
TRIGger:ATRigger:EXECuted?.....	173
TRIGger:ATRigger[:STATe].....	174
TRIGger:BURSt:DElay.....	173
TRIGger:COUNt.....	174
TRIGger:DElay.....	174
TRIGger:DElay:AUTO.....	175
TRIGger:DTIME.....	175
TRIGger:EXternal<2...2>:IMPedance.....	175
TRIGger:HOLDoff.....	176
TRIGger:HYSteresis.....	176
TRIGger:IMMediate.....	176
TRIGger:LEVel.....	176
TRIGger:LEVel:UNIT.....	177
TRIGger:SENDER:PORT.....	177
TRIGger:SENDER:STATe.....	178
TRIGger:SLOPe.....	178
TRIGger:SOURce.....	178
TRIGger:SYNC:PORT.....	180
TRIGger:SYNC:STATe.....	180
UNIT:POWer.....	135

# Index

- A**
- About ..... 12
  - Antenna connector ..... 30
  - Antenna module
    - Dual polarized ..... 32
    - Instrument tour ..... 32
    - LED ..... 34
    - NRPM-A90, NRPM-A90D ..... 32
    - Single polarized ..... 32
  - Antenna module cable ..... 37
  - Antenna module cable connector
    - Interface module ..... 36
  - Application cards ..... 16
  - Application notes ..... 16
- B**
- Brochures ..... 16
  - Browser-based user interface ..... 66
- C**
- C/C++ VISA
    - Programming examples ContAv (three antenna modules) ..... 189
    - Programming examples trace mode (three antenna modules) ..... 202
  - Checking the components ..... 17
  - Commands
    - Remote control ..... 112
  - Common commands ..... 114
  - Computer
    - Simple USB connection ..... 47
  - CONDition ..... 97
  - Configuration
    - Averaging ..... 76
    - Continuous average ..... 72
    - General ..... 74
    - sensor module ..... 74
    - System ..... 79
    - Trace ..... 73
    - Trigger ..... 77
  - Connect
    - Feedthrough module ..... 44
    - Interface module ..... 46
  - Connecting
    - Controller PC ..... 46
    - Front end ..... 44, 46
    - Connecting the R&S NRPM3(N)
      - RF frontend ..... 43
    - Connecting the sensor module
      - Host interface ..... 48
    - Connecting the sensor module and PC
      - USB ..... 48
    - Connection
      - Measurement setup ..... 43
    - Connector
      - Antenna ..... 30
      - Host interface ..... 30
      - LAN ..... 31
      - Trigger I/O ..... 31
    - ContAv
      - Multi sensor measurement ..... 62
      - Single sensor measurement ..... 60
    - Continuous average
      - Parameters ..... 72
    - Continuous average measurement
      - Programming examples ..... 187
    - Control
      - Measurement ..... 137
    - Controller PC
      - Setting up the connection ..... 46
      - USB connection ..... 47
    - Controlling host
      - Computer using LAN ..... 50
    - Customer support ..... 210
- D**
- Data sheets ..... 16
  - Diagnostics
    - Selftest ..... 203
  - Diode detector ..... 32
  - Disconnect
    - Interface cable ..... 45
    - Interface module ..... 46
  - Disconnecting the sensor module
    - Host interface ..... 48
  - Disposal ..... 212
  - Documentation overview ..... 15
  - Driver software
    - Useful links ..... 22
  - Dropout time
    - Trigger ..... 139

**E**

Electromagnetic interference (EMI) .....	19
Electrostatic discharge (ESD) .....	18
ENABLE .....	98
Ethernet (LAN) interface	
Remote control .....	91
EVENT .....	98

**F**

Feedthrough module	
Antenna module cable connector .....	35
How to connect .....	44
NRPM-ZD3 .....	35
Sensor module cable connector .....	35
Filter terminal control .....	77
Filtered cable feedthrough module .....	35
Instrument tour .....	34
Filtered cable interface module	
Instrument tour .....	36
Firmware update .....	205, 206
Firmware update for R&S NRP family program .....	84
Hardware requirements .....	83
NRPM3 .....	83
Over LAN .....	84
Potential risks .....	83
Problems .....	204
Remote control .....	87
Software requirements .....	83
Updating .....	83
Web browser-based user interface .....	86
Firmware update for R&S NRP family .....	84
Firmware update for R&S NRP family pro- gram	
Firmware update .....	84
Front end	
Setting up the connection in an RF shield- ed box .....	44
Setting up the connection in an RF test chamber .....	46

**G**

General functions	
Remote control commands .....	120

**H**

Hardware requirements	
Firmware update .....	83
NRPM3(N) OTA .....	20

**HiSLIP**

Protocol .....	93
Resource string .....	92
Hold-off time	
Trigger .....	140
Host interface	
How to: connect the cable .....	48
How to: disconnect the cable .....	48
Host interface connector .....	30
Hostname .....	55
How to:	
Connect the feedthrough module .....	44
Connect the interface module .....	46
Connect the sensor module and PC using USB .....	48
Disconnect the cable from the host inter- face of the sensor module .....	48
Disconnect the interface cable .....	45
Disconnect the interface module .....	46

**I**

Installation	
Drivers .....	23
NRP toolkit .....	24
NRP toolkit on Linux .....	26
NRP toolkit on macOS .....	27
NRP toolkit on MS Windows .....	24
Power viewer .....	27
Power viewer on Linux .....	28
Power viewer on macOS .....	28
Power viewer on MS Windows .....	27
Software .....	23
VISA .....	24
VISA on MS Windows .....	24
Instrument security procedures .....	15
Instrument tour .....	29
Interface module connected .....	37
NRPM antenna modules .....	32
NRPM-Z3 .....	36
NRPM-Z3 connected to NRM3 .....	37
NRPM-ZD3 .....	34
NRPM3 .....	29
Intended use .....	9
Interface cable .....	33
How to disconnect .....	45
Interface module .....	36
Antenna module cable connector .....	36
Connector to sensor module .....	36
How to connect .....	46



- How to disconnect ..... 46
- Strain relieve ..... 37
- Interface module connected
  - Instrument tour ..... 37
- IP address ..... 56
- K**
- Key features ..... 12
- Keywords
  - optional ..... 114
- L**
- Labels ..... 10
- LAN connection
  - Configuration ..... 205
  - Hostname ..... 55
  - IP address ..... 56
  - Problems ..... 205
  - Setup ..... 54
- LAN connector ..... 31
- LAN interface ..... 91
- LAN reset ..... 31
- LED
  - Antenna module ..... 34
  - Network status ..... 31
  - Power over Ethernet ..... 31
  - Status ..... 30
- Linux
  - NRP toolkit installation ..... 26
  - Power viewer installation ..... 28
- List mode measurement
  - Programming example (pseudo code)
    - ..... 194
  - Programming examples ..... 192
- Low-level communication program ..... 206
- M**
- macOS
  - NRP toolkit installation ..... 27
  - Power viewer installation ..... 28
- Maintenance ..... 212
- Measurement
  - Control ..... 137
  - Start ..... 57
- Measurement mode ..... 72
  - Continuous average ..... 72
  - Programming examples ..... 149
  - Remote control commands ..... 148
  - Trace ..... 73
- Measurement setup
  - Connection ..... 43
  - NRPM ..... 38
  - Overview ..... 38
  - RF shielded box ..... 42
- Measurement tasks
  - NRPM ..... 187
  - Programming examples ..... 187
- Measurements
  - Multi sensor ContAv ..... 62
  - NRPM ..... 58
  - Power viewer ..... 59
  - Power viewer on MS Windows ..... 59
  - Single sensor ContAv ..... 60
  - Single sensor trace ..... 64
- MS Windows
  - NRP toolkit installation ..... 24
  - Power viewer installation ..... 27
  - Power viewer measurements ..... 59
  - VISA driver installation ..... 24
- Multi sensor measurement
  - ContAv ..... 62
- N**
- Network status LED ..... 31
- NRP toolkit
  - Installation ..... 23, 24
- NRPM
  - Measurement setup ..... 38
  - Measurement tasks ..... 187
  - Measurements ..... 58
  - Remote control ..... 89
- NRPM antenna modules
  - Instrument tour ..... 32
- NRPM-A90
  - Antenna module cable ..... 37
  - Interface cable ..... 33
  - Single polarized antenna module ..... 32
- NRPM-A90D
  - Antenna module cable ..... 37
  - Dual polarized antenna module ..... 32
  - Interface cable ..... 33
- NRPM-Z3
  - Antenna module cable connector ..... 36
  - Connector to sensor module ..... 36
  - Instrument tour ..... 36
  - Interface module ..... 36
  - Strain relieve ..... 37
- NRPM-Z3 connected to NRM3
  - Instrument tour ..... 37

- NRPM-ZD3
  - Cable connector ..... 35
  - Feedthrough module ..... 35
  - Instrument tour ..... 34
- NRPM3
  - Firmware update ..... 83
  - Instrument tour ..... 29
- NRPM3(N)
  - Antenna connector ..... 30
  - Host interface connector ..... 30
  - Sensor module ..... 12
  - Status LED ..... 30
  - Trigger I/O connector ..... 31
- NRPM3N
  - LAN connector ..... 31
  - LAN reset ..... 31
  - Network status LED ..... 31
  - PoE LED ..... 31
- NTRansition ..... 98
- O**
- Open source acknowledgment (OSA) ..... 16
- Operating concepts
  - Browser-based user interface ..... 66
- Operating conditions ..... 17
- OTA power measurement solution
  - About ..... 12
  - Documentation overview ..... 15
  - Preparing for use ..... 17
  - Welcome ..... 12
- Overview
  - Documentation ..... 15
  - Measurement setup ..... 38
- P**
- Parameter
  - Averaging ..... 76
  - Common ..... 70
  - Continuous average ..... 72
  - General ..... 74
  - sensor module ..... 74
  - System ..... 79
  - Trace ..... 73
  - Trigger ..... 77
- PoE LED ..... 31
- Power supply ..... 20
- Power unit
  - Remote control commands ..... 135
- Power viewer ..... 21, 22
  - Installation ..... 23, 27
  - Measurements ..... 59
  - Start ..... 60
  - Useful links ..... 23
- Preparing for use ..... 17
  - Hardware requirements ..... 20
  - Installation ..... 23
  - Instrument tour ..... 29
  - Software requirements ..... 20
  - Unpacking and checking ..... 17
- Prevent antenna damage ..... 18
- Programming examples
  - Archives ..... 22
  - Continuous average measurement ... 187
  - List mode measurement ..... 192
  - List mode measurement (pseudo code)
    - ..... 194
  - Measurement mode ..... 149
  - Measurement tasks ..... 187
  - Simplest measurement ..... 187
  - Single sensor ContAv measurement (C/C++ VISA) ..... 189
  - Single sensor ContAv measurement (pseudo code) ..... 189
  - Single sensor ContAv measurement (Python) ..... 190
  - Single sensor ContAv measurement (SCPI) ..... 188
  - Single sensor trace measurement (C/C++ + VISA) ..... 202
  - Single sensor trace measurement (pseudo code) ..... 201
  - Single sensor trace measurement (SCPI) ..... 200
  - Three antenna modules ContAv (C/C++ VISA) ..... 189
  - Three antenna modules ContAv (Python) ..... 190
  - Three antenna modules ContAv (SCPI) ..... 188
  - Three antenna modules trace (C/C++ VISA) ..... 202
  - Three antenna modules trace (SCPI) ..... 200
  - Two antenna modules ContAv (pseudo code) ..... 189
  - Two antenna modules trace (pseudo code) ..... 201
  - Useful links ..... 21, 22, 23

- Protocol
  - HiSLIP ..... 93
  - VXI-11 ..... 93
- Pseudo code
  - Programming examples ContAv (two antenna modules) ..... 189
  - Programming examples list mode .... 194
  - Programming examples trace (two antenna modules) ..... 201
- PTTransition ..... 98
- Python
  - Programming examples ContAv (three antenna modules) ..... 190
- R**
- R&S NRP Toolkit
  - Communication program ..... 206
  - Firmware update ..... 205, 206
  - Network Configuration ..... 205
  - S-parameter update ..... 206
  - Uncertainty calculator ..... 206
  - Versions of software ..... 206
- Regulatory information ..... 9
- Release notes ..... 16
- Remote control
  - Commands ..... 112
  - Common commands ..... 114
  - Ethernet (LAN) interface ..... 91
  - HiSLIP protocol ..... 93
  - Interfaces ..... 89
  - NRPM ..... 89
  - Protocols ..... 89
  - Socket communication ..... 94
  - USB interface ..... 90
  - USB resource string ..... 90
  - VISA resource strings ..... 91
  - VXI-11 protocol ..... 93
- Remote control commands
  - General functions ..... 120
  - Measurement mode ..... 148
  - Power unit ..... 135
  - Results ..... 148
- Replacing antenna cables ..... 206
- Reset
  - LAN ..... 31
- Resource string
  - HiSLIP ..... 92
  - Socket ..... 93
  - VISA ..... 91
  - VXI-11 ..... 92
- Results
  - Remote control commands ..... 148
- RF frontend
  - Connecting the R&S NRPM3(N) ..... 43
- RF shielded box
  - Measurement setup ..... 42
  - Setting up front end connection ..... 44
- RF shielded chamber
  - Setting up front end connection ..... 46
- S**
- S-parameter update ..... 206
- Safety information ..... 9, 17
- Safety instructions ..... 9, 15
- SCPI
  - Programming examples ContAv (three antenna modules) ..... 188
  - Programming examples measurement mode ..... 149
  - Programming examples simplest measurement ..... 187
  - Programming examples trace mode (three antenna modules) ..... 194, 200
- Scripting tool ..... 22
- Security procedures ..... 15
- Selftest ..... 203
- Sensor module
  - Instrument tour ..... 29
- Serial number ..... 11
- Setting
  - See parameter ..... 69
- Simplest measurement
  - Programming examples ..... 187
- Single sensor measurement
  - ContAv ..... 60
  - ContAv programming examples (C/C++ VISA) ..... 189
  - ContAv programming examples (pseudo code) ..... 189
  - ContAv programming examples (Python) ..... 190
  - ContAv programming examples (SCPI) ..... 188
  - Trace ..... 64
  - Trace programming examples (C/C++ VISA) ..... 202
  - Trace programming examples (pseudo code) ..... 201
  - Trace programming examples (SCPI) ..... 200

- Socket
  - Communication ..... 94
  - Resource string ..... 93
- Software requirements
  - Firmware update ..... 83
  - Mandatory ..... 21
  - NRP toolkit ..... 21
  - NRPM3(N) OTA ..... 20
  - Optional ..... 22
  - Power viewer ..... 21, 22
  - Programming example (links) ..... 21, 22
  - VISA ..... 21
- Special characters
  - SCPI ..... 114
- Start measurement ..... 57
- Status
  - Information ..... 203
- Status LED ..... 30
- Status registers
  - CONDition ..... 97
  - ENABle ..... 98
  - EVENT ..... 98
  - NTRansition ..... 98
  - PTRansition ..... 98
  - Sum bit ..... 99
- Storage ..... 212
- Suffixes ..... 113
- Sum bit ..... 99
- T**
- Target audience ..... 9
- Test setup
  - Considerations ..... 18
- Three antenna modules
  - Programming examples ContAv (C/C++ VISA) ..... 189
  - Programming examples ContAv (Python) ..... 190
  - Programming examples ContAv (SCPI) ..... 188
  - Programming examples trace mode (C/C++ VISA) ..... 202
  - Programming examples trace mode (SCPI) ..... 200
- Three antenna modules test setup ..... 38
- Toolkit ..... 21
- Trace
  - Parameters ..... 73
  - Single sensor measurement ..... 64
- Transporting ..... 211
- Trigger
  - Dropout time ..... 139
  - Hold-off time ..... 140
- Trigger I/O connector ..... 31
- Trigger1 ..... 30
- Troubleshooting ..... 203
  - Firmware update ..... 204
  - LAN connection problems ..... 205
  - Selftest ..... 203
  - Status information ..... 203
- Tutorials ..... 15
- Two antenna modules
  - Programming examples ContAv (pseudo code) ..... 189
  - Programming examples trace mode (pseudo code) ..... 201
- U**
- Uncertainty calculator ..... 206
- Unit ..... 69
- Unpacking the components ..... 17
- USB
  - How to: connect the sensor module and PC ..... 48
- USB connection ..... 47
- USB interface
  - Remote control ..... 90
  - Resource string ..... 90
- USB resource string ..... 91
- USB sensor hub ..... 48
- USBTMC ..... 21
- Useful links
  - Driver software ..... 22
  - Power viewer ..... 23
  - Programming examples ..... 22, 23
- User manual ..... 15
- V**
- Versions of software ..... 206
- VISA ..... 21
  - Driver installation ..... 23, 24
  - Resource string ..... 91
- VXI-11
  - Protocol ..... 93
  - Resource string ..... 92
- W**
- Warning message ..... 11
- Web browser-based user interface
  - Main dialog ..... 68

Welcome	
Key features .....	12
OTA power measurement solution .....	12
White papers .....	16
<b>Z</b>	
Zero configuration networking .....	54