

HIOKI

SF1001

Instruction Manual

POWER LOGGER VIEWER

EN

May 2015 Revised edition 3
SF1001A981-03 15-05H



User's License Agreement

Important

Please read the following agreement carefully. This user's license agreement (hereafter referred to as Agreement) is a legal contract between the software user (individual or institution) and HIOKI E. E. CORPORATION (hereafter referred to as HIOKI). The term "software" includes any related electronic documentation and computer software and media, as well as any printed matter (such as the Instruction Manual).

By installing, reproducing, or using the software, you, the Licensee, agree to accept the license terms set forth in this Agreement.

This software is protected by copyright laws, international copyright agreements, as well as non-corporate laws. The software is a licensed product, and is not sold to the user.

1. License

This Agreement grants you, the Licensee, a license to install a single copy of the software on a specified computer system.

2. Explanation of other rights and restrictions

-1. Restrictions on reverse engineering, decompiling, and disassembling:

You may not reverse engineer, decompile, or disassemble the software.

-2. Separation of components:

This software is licensed for use as a single product. You may not separate the components for use on multiple computer systems.

-3. Loaning:

You may not loan or lease the software.

-4. Transfer of software:

You may transfer full rights in accordance with this Agreement. However, if you do so, you may not retain any copy of the software, but must transfer the software in its entirety (all components, media, related documentation such as the Instruction Manual, and this Agreement), and must ensure that the receiver of the software agrees with the terms set forth in this Agreement.

-5. Cancellation:

In the event that the terms and conditions set forth in this Agreement are violated, HIOKI retains the right to cancel this Agreement without compromise of any of its other rights. In this event, you must destroy all copies of the software and its components.

3. Copyright

The title and copyright rights concerning the software's related documentation, such as the Instruction Manual and copies of the software, are the property of HIOKI and other licensors, and are protected by copyright laws and international agreement regulations. Accordingly, you must treat the software as you would any other copyrighted document. However, you are permitted to make copies as indicated in (A) and (B) below provided such copies are not intended for use other than back-up purposes.

(A) You may make a single copy of the software.

(B) You may install this software on a single computer.

However, you may not reproduce the documentation supplied with the software, such as the Instruction Manual.

4. Dual media software

You may receive the same software on more than one type of media. However, regardless of the type and size of media provided, you may only use one media type and only on a single computer. You must not use or install the other media on any other computer. Furthermore, except when transferring the software as stipulated above, you may not loan, lease, or transfer the other media to any other user.

5. Warranty

- 1. HIOKI reserves the right to make changes to the software specifications without any prior warning.
 - 2. If the software does not operate in accordance with the supplied Instruction Manual, or the software media or Instruction Manual are damaged in any way, you have one year from the date of purchase to apply for either an exchange or repair at HIOKI's discretion.
 - 3. In no event will HIOKI be liable for any damages resulting from fire, earthquake, or actions of a third party under the conditions stated in item number 2 above, or for any damage caused as a result of your using the software incorrectly or under unusual circumstances. Further, the warranty is invalid if the following occurs:
 - (A) Damage incurred through transport, moving, droppage, or any other kind of impact after you purchased the software.
 - (B) Damage incurred through any form of alteration, unwarranted servicing, or any other type of mistreatment.
 - 4. In the event that the software is exchanged or repaired, the period of warranty expires on the latest occurring date out of the day stated in the original warranty, and exactly 6 months from the day the exchanged/repaired software is returned to you.
 - 5. Regardless of the grounds for making a legal claim, HIOKI and its licensors will not be liable for any damage incurred (including, but not limited to: lost profits, suspension of business, loss of data or lost savings) unstated in the warranty terms for the use of this software. This is true even if HIOKI is notified of the possibility of such damages. In any event, HIOKI's liability shall be limited only to replacing defective software with software that is not defective.
-

Contents

Introduction	1
Confirming Package Contents	1
Notation	1
Mouse Operation	2
Notes on Use	2

Chapter 1 Product Overview 3

Chapter 2 Before Viewing Data 5

2.1 System Requirements	5
2.2 Installing the Software	6
Uninstalling the Software	6
2.3 Launching the SF1001	7
Exiting the SF1001	7
2.4 Loading a Measurement-data File	8
Loading Folders	
(Model PW3360, Model PW3365)	9
Loading Files	12
Changing a Data Name	15
Changing the Facility Capacity Setting	16
Deleting a Data File from the List	17
Deleting All Data Files on the Llist	18
Loading data logger recorded data	19
2.5 Saving Data in CSV Format	21
2.6 Saving in a Combined File Under a	
New File Name	23
Loading a Combined File	24
Saving a Combined File	24
2.7 Settings at Startup of the SF1001 ...	25
2.8 Changing the Date of	
Measurement Data	26

Chapter 3 Screen Configuration 31

3.1 Screens	31
3.2 Common Interface Elements and	
Functionality	32
Menu Bar	33

Toolbar	34
Pasting to the Clipboard	34

Chapter 4 Displaying a Time-series Graph 35

4.1 Select Data Items and Graph type	
to Display	36
4.2 Select Detail Items	37
4.3 Set Data Interval for the Displayed	
Data	39
4.4 Setting the Graph Display Start	
and End Time and Date	40
4.5 Move Display Range	41
4.6 Set Display Period	42
4.7 Displaying the Value at the Cursor	
Position	43
4.8 Set Vertical Axis	44
4.9 Changing the Maximum Number	
of Display Items	45
4.10 Change Display Unit	46
4.11 Change Background Color	47
4.12 Set time display down to seconds	
or lower digit	48

Chapter 5 Displaying Summary 49

5.1 Select Data Items to Display	50
5.2 Set Data Interval for the Displayed Data	
.....	52
5.3 Set Display Time	53
5.4 Move Display Range	54
5.5 Set Display Period	55
5.6 Scroll Screen	56
5.7 Change Display Unit	57
5.8 Change Column width	58

Chapter 6 Displaying the Report: Daily/ Weekly/ Monthly 59

6.1	Select Data Items to Display	60
6.2	Select Demand Period	62
6.3	Set the Start Date	63
6.4	Move Display Range	64
6.5	Select a Report	65
6.6	Scroll Screen	66
6.7	Change Display Unit	67
6.8	Changing the Report Column Width	68
6.9	Displaying the Load Factor and Demand Factor	69
6.10	Displaying Active Energy by Time of Day	70
6.11	Displaying Active Energy Converted into CO2 Amount	72

Chapter 7 Displaying a Harmonic List 73

7.1	Select Data Channel to Display	74
7.2	Select Detail Items	75
7.3	Setting the Display Time	76
7.4	Change Display Unit	77

Chapter 8 Displaying a Harmonic Graph 79

8.1	Select Data Items to Display	80
8.2	Select Detail Items	80
8.3	Setting the Display Time	82
8.4	Setting the Axis to a Linear Axis or LOG Axis	82
8.5	Displaying the Value at the Cursor Position	82
8.6	Set Vertical Axis	83

8.7	Change Display Unit	84
8.8	Change Background Color	85

Chapter 9 Displaying Measurement Data Waveforms 87

9.1	Selecting the Waveform Display Data	88
9.2	Toggleing the Waveform Display On and Off	89
9.3	Setting the Start Time	89
9.4	Displaying the Value at the Cursor Position	90
9.5	Changing the Graph Display	90
9.6	Set Vertical Axis	91
9.7	Change Display Unit	92
9.8	Change Background Color	93

Chapter 10 Displaying Settings for Measurement Data 95

10.1	Select Measurement Data	96
10.2	Set Column Width	96

Chapter 11 Printing 97

11.1	Printing Screens	97
11.2	Printing Reports	100

Chapter 12 Specifications 105

12.1	General Specifications	105
12.2	Functional Specifications	106
12.3	Calculation Formulas	110

Introduction

Thank you for purchasing the HIOKI Model SF1001 Power Logger Viewer. To obtain maximum performance from the software, please read this manual first, and keep it handy for future reference.

Trademarks

Windows and Internet Explorer are a registered trademark of Microsoft Corporation in the United States and/or other countries.

Confirming Package Contents

When you receive the software, inspect it carefully to ensure that no damage occurred during shipping. If damage is evident, or if it fails to operate according to the specifications, contact your dealer or Hioki representative.

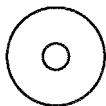

Application disk (1)
"SF1001 Power Logger Viewer, Instruction Manual (This file)"

Notation

The following symbols in this manual indicate the relative importance of cautions and warnings.

 **CAUTION** Indicates that incorrect operation presents a possibility of injury to the user or damage to the software.

NOTE Indicates advisory items related to performance or correct operation of the software.

(p.) Indicates the location of reference information.

* Indicates that descriptive information is provided below.

[] Menus, commands, dialogs, buttons in a dialog, and other names on the screen and the keys are indicated in brackets.

Windows Unless otherwise specified, "Windows" represents Windows XP SP3 (32 bit version) or more, Windows Vista SP2 (32 bit version) or more, Windows 7 SP1 (32/64 bit version) or more, and Windows 8 (32/64bit version).

Dialog Dialog box represents a Windows dialog box.

Mouse Operation

Click	Press and quickly release the left button of the mouse.
Right-click	Press and quickly release the right button of the mouse.
Double click	Quickly click the left button of the mouse twice.
Drag	While holding down the left button of the mouse, move the mouse and then release the left button to deposit the chosen item in the desired position.

Notes on Use

CAUTION

- Always hold the disc by the edges, so as not to make fingerprints on the disc or scratch the printing.
- Never touch the recorded side of the disc. Do not place the disc directly on anything hard.
- Do not wet the disc with volatile alcohol or water, as there is a possibility of the label printing disappearing.
- To write on the disc label surface, use a spirit-based felt pen. Do not use a ball-point pen or hard-tipped pen, because there is a danger of scratching the surface and corrupting the data. Do not use adhesive labels.
- Do not expose the disc directly to the sun's rays, or keep it in conditions of high temperature or humidity, as there is a danger of warping, with consequent loss of data.
- To remove dirt, dust, or fingerprints from the disc, wipe with a dry cloth, or use a CD cleaner. Always wipe from the inside to the outside, and do no wipe with circular movements. Never use abrasives or solvent cleaners.
- Hioki shall not be held liable for any problems with a computer system that arises from the use of this CD, or for any problem related to the purchase of a Hioki product.

Product Overview

Chapter 1

The SF1001 Power Logger Viewer is a software application for graphing measurement data recorded using the Hioki power meter (Model PW3360, model PW3365, and model 3169) with a computer.

The SF1001 has the following functions.

◆ Time-series Graph Display

Displays measurement data in a time-series graph. When the demand in each system is measured separately, these measurements will be displayed one on top of another.

◆ Summary Display

Displays a list of measurement data.

◆ Daily, Weekly, and Monthly Report Display

Displays a daily, weekly, or monthly report of measurements.

◆ Harmonic Display

Displays harmonic measurement data in the form of a graph or list.

◆ Waveform Display

Displays waveform data in the form of a graph.

◆ Printing

Prints out the screen image on the printer connected to the PC.

◆ Report Printing

Create and print reports about time-series graphs; summary; daily report; harmonic graph; harmonic list; and waveform for loaded measurement data.

◆ Data Combination

Combines up to 16 pieces of measurement data of the Hioki power meter (Model PW3360, PW3365, and 3169). The data is saved and read out as a single combined file.

NOTE Manually saved data of the 3169 Clamp on Power HiTester cannot be loaded.



Before Viewing Data

Chapter 2

Install and launch the SF1001 application.

Load measurement data. (You can load measurement data saved with the PW3360, the PW3365, and the 3169 or files saved in the SF1001 file format.)

2.1 System Requirements

The computer running the SF1001 program must satisfy the following requirements.

OS	English/ Chinese version <ul style="list-style-type: none"> • WindowsXP SP3 or more (32bit version) • WindowsVista SP2 or more (32bit version) • Windows7 SP1 or more (32/64bit version) • Windows8/8.1 (32/64bit version)
CPU	1.0 GHz or more (2.0 GHz or more recommended)
Memory	1.0 GHz or more (2.0 GHz or more recommended) *For Windows7, 8/8.1 (64-bit version), 2.0 GB or more
Hard Disk	Free disk space of 128 MB or more (at launch)
Display	Resolution 1024 x 768 dots or more, 65536 colors or more
Disk System	CD-ROM drive (Used only for installation)
Printer	Required for screen image or report printing on the computer. Either color or monochrome can be used.

- NOTE**
- For some models, proper operation cannot be guaranteed even when the above requirements are satisfied.
 - To transfer data from a PW3360 or a PW3365 to a Computer, SD memory card is required.
 - To transfer data from a 3169 to a Computer, PC card is required.

2.2 Installing the Software

Use the following procedure to install the software.

1 Set up the computer.

Shut down all currently running applications.

2 Insert the supplied CD into the CD-ROM drive.

3 Double-click the setup file (setup.exe) contained in the "English" or "Chinese" folder.

Installation of the SF1001 application will begin.

If the SF1001 installer does not launch automatically, double-click **[Start]-[Computer]-[Devices with Removable Storage]-[SF1001]** on the Windows menu.

4 Follow the directions on the screen to complete the installation.

NOTE

- If other application are running it may not be possible to complete the installation. As far as possible, close all other applications before beginning the installation. In particular, if any anti-virus software is running, it may prevent the installation, even though it is not a virus. In this case, make the appropriate settings in the anti-virus software to allow the installation to proceed.
- Following installation, the computer may need to be restarted.

Uninstalling the Software

Use the following procedure to uninstall the software.

1 In the Windows Start menu, select **[Start]-[Control Panel]**.

2 Click the **[Programs]-[Uninstall a program]** icon, to display the **[Programs and Features]** dialog.

3 In the **[Uninstall or change a program]** tab of the dialog, click on **[SF1001 Power Logger Viewer]** in the list of applications, and click **[Uninstall]**.

This runs the uninstaller, which removes the SF1001 software.

2.3 Launching the SF1001

Use the following procedure to launching the software.

1 In Windows, select **[Start]-[All programs]-[HIOKI]-[SF1001]-[SF1001 Power Logger Viewer]**.

2 The main screen appears.

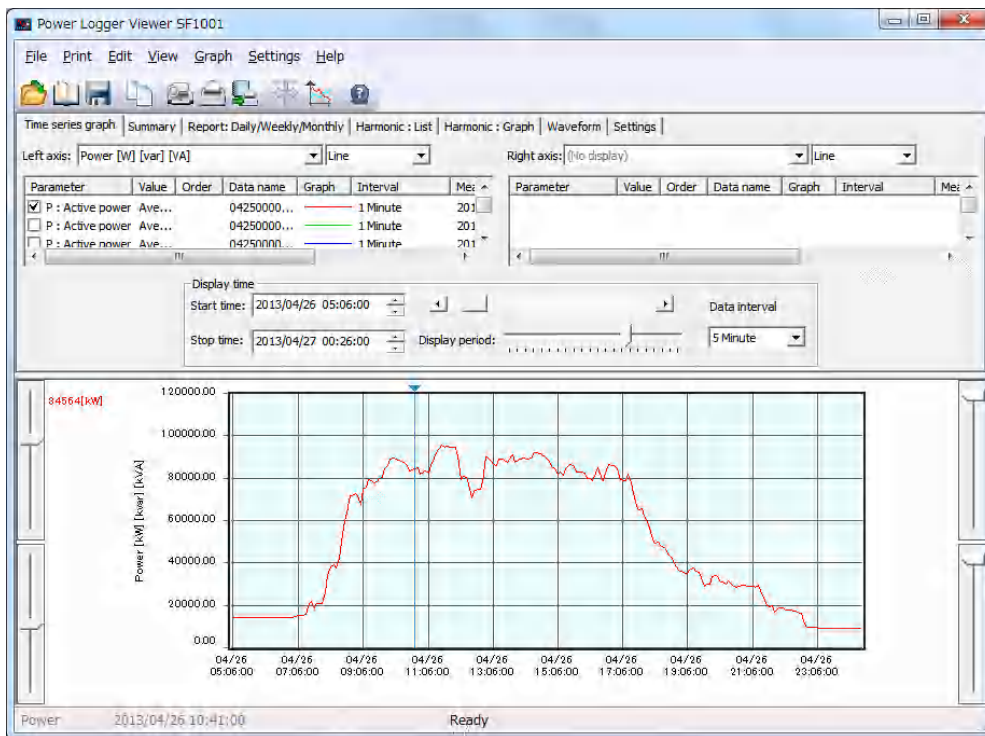

Exiting the SF1001

Select **[File]-[Exit]** on the menu bar.

You can also click **[x]** (Close) at the top right corner of the window to close the application.

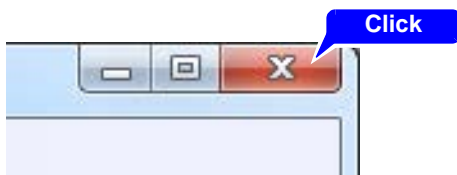

2.4 Loading a Measurement-data File

This section describes how to load data recorded by the instrument. The following data files can be loaded:

Model number	File type	Contents of data	File type	Extension
PW3360	Measurement data file	Maximum value, Minimum value, Average value, Integrated value, Demand value	CSV file	.csv
	Harmonic data file	Harmonic data	Binary file	.hrm
	Waveform data file	Waveform data	Binary file	.wui
PW3365	Measurement data file	Maximum value, Minimum value, Average value, Integrated value, Demand value	CSV file	.csv
	Waveform data file	Waveform data	Binary file	.wui
3169	Measurement data file	Instantaneous value, Maximum value, Minimum value, Average value, Integrated value, Demand value, Harmonic waveform data	CSV file	.csv
	Waveform data file	Waveform data	Binary file	.wui
	Short-term-interval data file	Instantaneous value	Binary file	.bin
SF1001	Combined file	Combined file	Binary file	.da2
9625	Combined file	Combined file	Binary file	.dat
Data Logger	Recorded data file	Instantaneous value, Maximum value, Minimum value, Average value	Binary file	.hrp2

NOTE

- The maximum total amount of data that can be loaded from files is as follows:
4 GB (when there is no binary file)
2 GB (when there is a binary file)
- The following files will be also loaded in addition to measurement data files.
Model PW3360: harmonic data file and waveform data file
Model PW3365: waveform data file
Model 3169: waveform data file
- A file cannot be loaded if it has been overwritten on a spreadsheet program.
- If a waveform data file or a short-term-interval data file is converted to a CSV file using binary CSV conversion software for the 3169, the CSV file cannot be loaded.
- Data recorded by a data logger can be loaded by opening it with the LR5000 utility software and converting it to a CSV file.
See: "Loading data logger recorded data" (p.19)

Loading Folders (Model PW3360, Model PW3365)

Data saved with Model PW3360 and PW3365 can be loaded by specifying a folder including the data. Loading a folder is not the same thing as loading all CSV files in the folder.

See: "Loading Files" (p.12)

- NOTE**
- If a data file exceeds 200 MB during measurement with Model PW3360 or PW3365, it will be divided into multiple files, being saved. Because all of the files divided into multiple files inside a folder are loaded as a single file when loading a folder, the loading process may take time.
 - If there is only one CSV file inside the loaded folder, the CSV filename will be used as the data name. However, if multiple CSV files have been loaded, the data name will be derived by changing the last two characters of the CSV filename to ##.
 - If you only wish to load one CSV file from a folder, see "Loading Files" (p.12).
 - When you load a folder containing CSV files with different measurement dates or measurement start times, only the data with the earliest measurement start time will be displayed. To load multiple data with different measurement dates or measurement start times, either load separate folders that contain only the data you wish to display, or load the desired files separately using "Load (Specify folder)".
 - Filenames can be checked and changed on the "Loading the file" dialog box.

1

Click the  button on the tool bar.

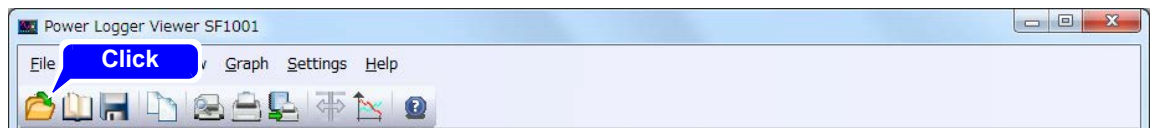

The "Load data file" dialog will appear.

2

Click the **[Load (specific folder)]**.

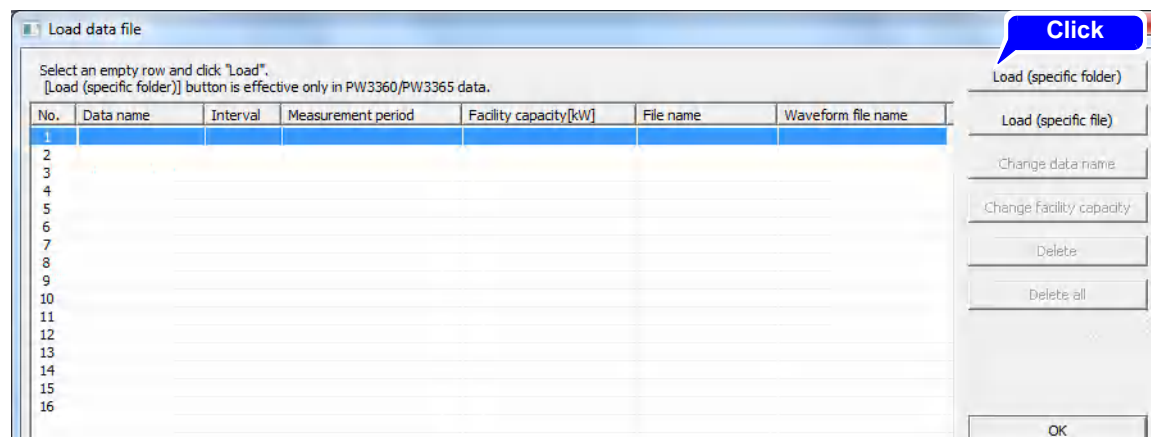

The "PW3360 Load data specified folder" dialog will appear.

10

2.4 Loading a Measurement-data File

3 Select a folder to be loaded, and click [OK].

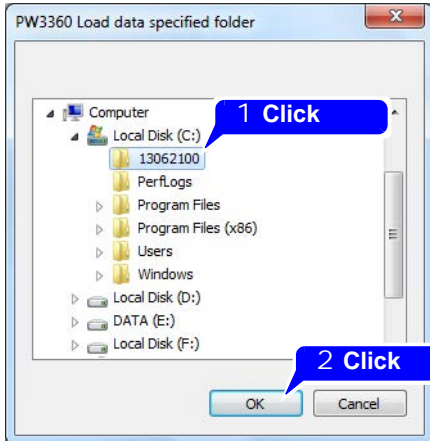

4 The "Loading the file" dialog will appear.

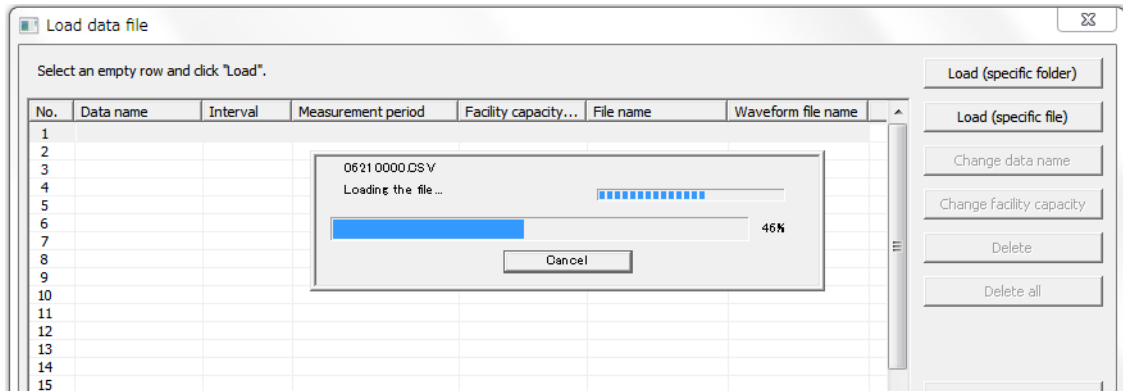

The CSV files in the folder will be loaded into the selected list row (up to 16 sets of data).

5 Click [OK].

- NOTE**
- Subsequent data loading times can be reduced by saving loaded data as a combined file. For more information about how to create a combined file, see "2.6 Saving in a Combined File Under a New File Name" (p.23).
 - When loading multiple large CSV files, the application may initially display "file merging."



- Folders containing 2 GB or more data cannot be loaded. An error message will be displayed.

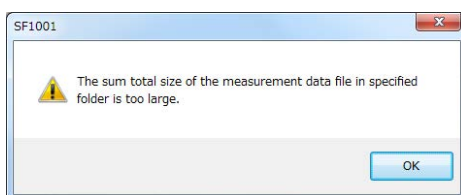

- If there is a folder named "HARMONIC" in the selected folder and a harmonic data file (with the extension .HRM) that has the same filename as the CSV file in that folder, the harmonic data file will also be loaded.
- If there is a folder named "AUTOWAVE" in the selected folder and a waveform data file (with the extension .WUI) that has the same filename as the CSV file in that folder, the waveform data file will also be loaded.
- Harmonic and waveform data files cannot be loaded independently.
- If the ABC folder is loaded as part of the folder hierarchy shown below, the following files will be loaded: ABC00.CSV, ABC00.HRM, and ABC00.WUI.

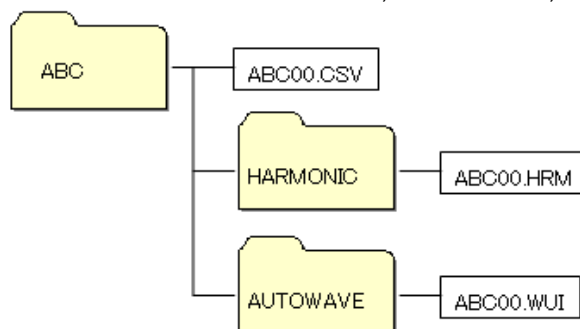

12

2.4 Loading a Measurement-data File

Loading Files

Load data files of Model PW3360, model PW3365, or model 3169.

- 1 Click the  button on the tool bar.

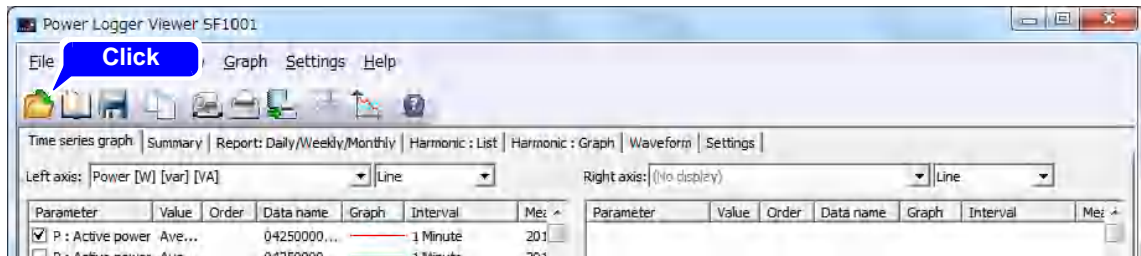

The "Load data file" dialog will appear.

- 2 Select an empty number in the list and click **[Load (specific file)]**.

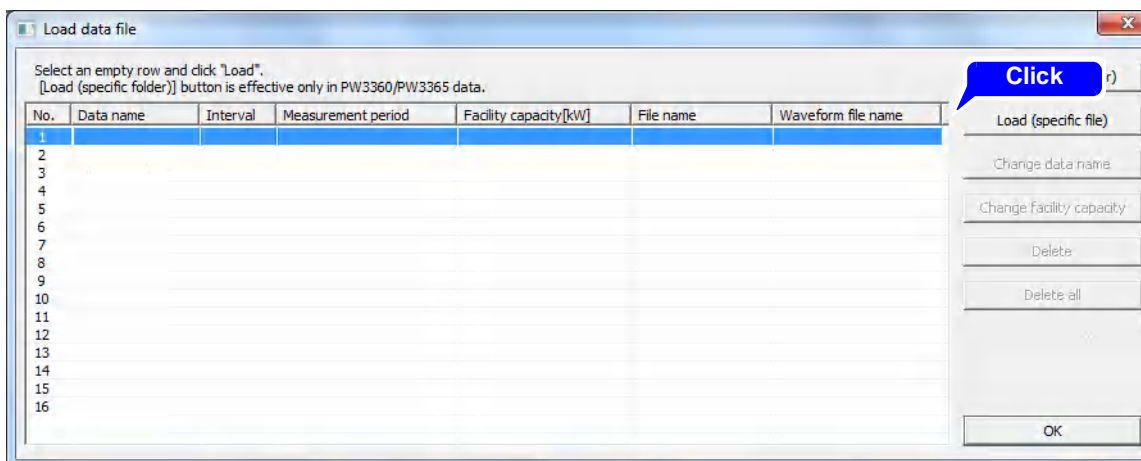

The "Open" dialog will appear.

- 3 Select a data file to be loaded, and click **[Open]**.

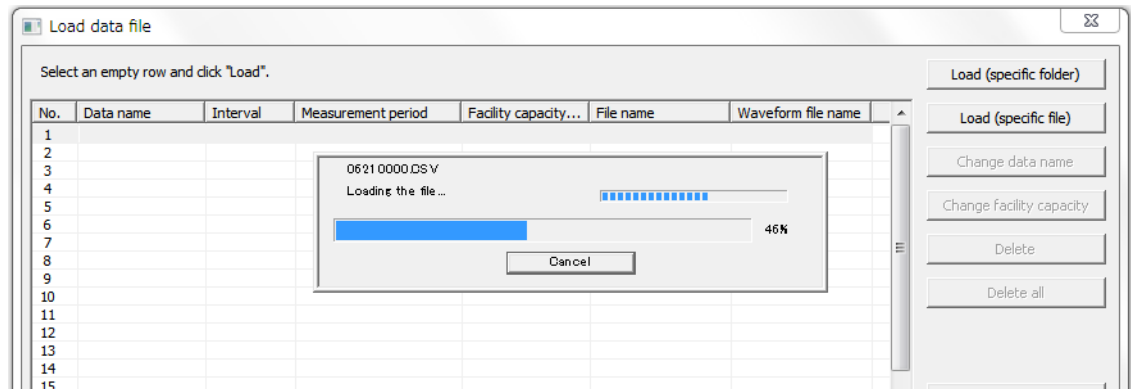

4 The “Load data file” dialog will appear.

The file will be loaded into the selected list row.

Up to 16 data files can be loaded.

To load multiple files, perform this procedure after selecting a list number for each file.

5 Click **[OK]**.

The loaded file data will be displayed.

2.4 Loading a Measurement-data File

NOTE

- Subsequent data loading times can be reduced by saving loaded data as a combined file. For more information about how to create a combined file, see "2.6 Saving in a Combined File Under a New File Name" (p.23).
- Only files containing measurements made by the PW3660, the PW3365, or the 3169 can be loaded using the "Load files" command. Combined files cannot be loaded. When loading combined files, see "Loading a Combined File" (p.24).
- It takes time to load large files. Load times will vary with the system configuration of the computer being used.

A rough guide for loading times is provided below:

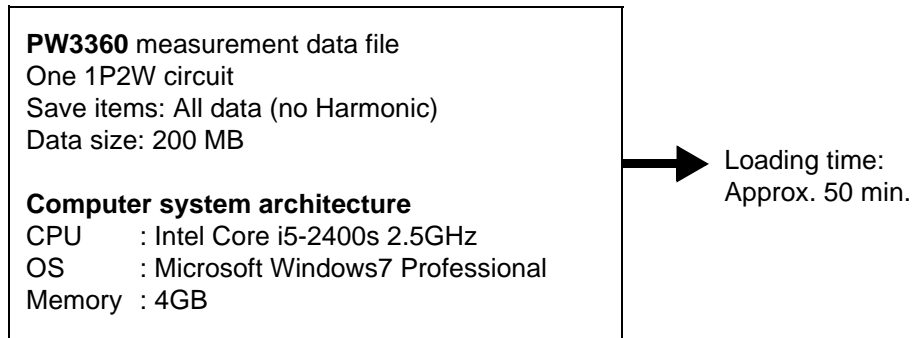

- For model PW3360, Harmonic and waveform data files cannot be loaded independently. If there is a folder named "HARMONIC" in the same folder as the selected CSV file and a harmonic data file (with the extension .HRM) that has the same filename as the CSV file in that folder, the harmonic data file will also be loaded.
- For model PW3360 and model PW3365, Waveform data files cannot be loaded independently. If there is a folder named "AUTOWAVE" in the same folder as the selected CSV file and a waveform data file (with the extension .WUI) that has the same filename as the CSV file in that folder, the waveform data file will also be loaded.

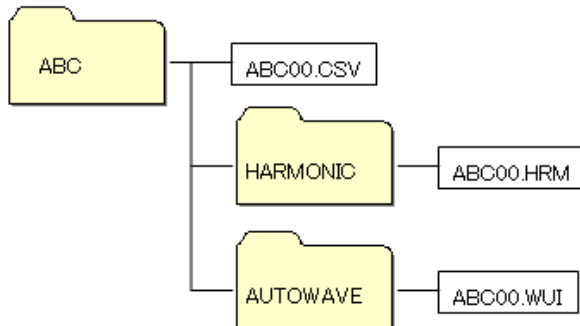

- For Model 3169, if there is a waveform data file that is the same type as the CSV file (extension: WUI), the waveform data file will also be loaded .
 If the name of the waveform data file differs from that of the measurement data file, no waveform data file can be loaded together with the loaded measurement data file.
 For files that was automatically named and saved with Model 3169, if the numbers "XX" in the name of the measurement data file "69MEASXX.CSV" differs from those in the name of the waveform data file "69WAVEXX.WUI", no waveform data file can be loaded.
 Harmonic and waveform data files cannot be loaded independently.
- For loading multiple data files, all of the files must have been obtained for a measurement period of one year or less.

Changing a Data Name

- 1 Click the  button on the tool bar.

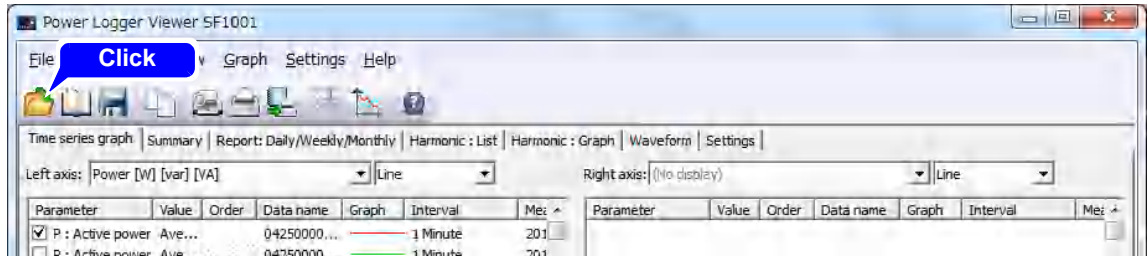

The “Load data file” dialog will appear.

- 2 Select the number of the data file you wish to change from the list and click [\[Change data name\]](#).

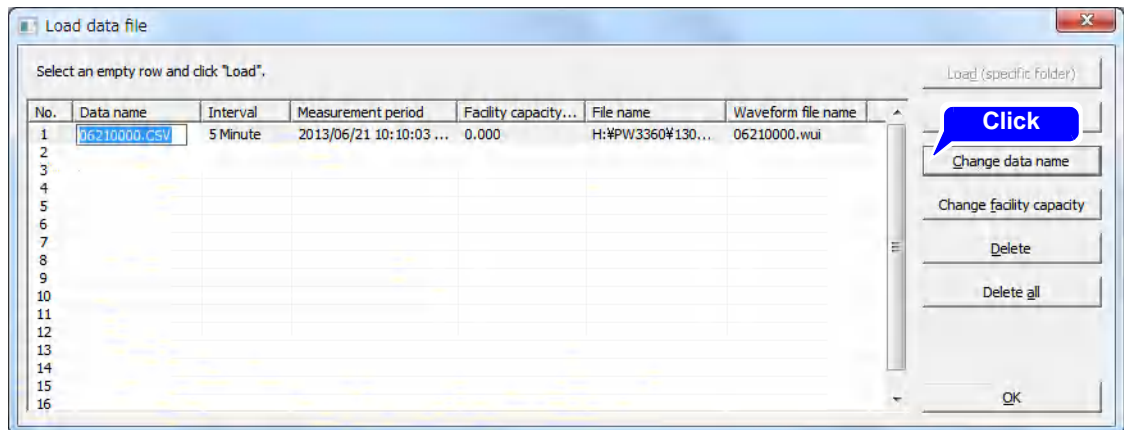

The data name will change only within the SF1001 application. The names of loaded files will not change. Data names can be up to 127 characters in length.

Changing the Facility Capacity Setting

You can calculate the demand factor for the active power demand value (consumption) by setting the equipment capacity*. The demand factor is displayed at the bottom of the table on the Report: Daily/Weekly/Monthly tab. The demand factor is not displayed initially because the default setting for the equipment capacity is 0 kW.

* Total of the rated capacity (maximum value for the product of the allowable voltage and current) for each load installed on the equipment you wish to measure

1 Click the  button on the tool bar.

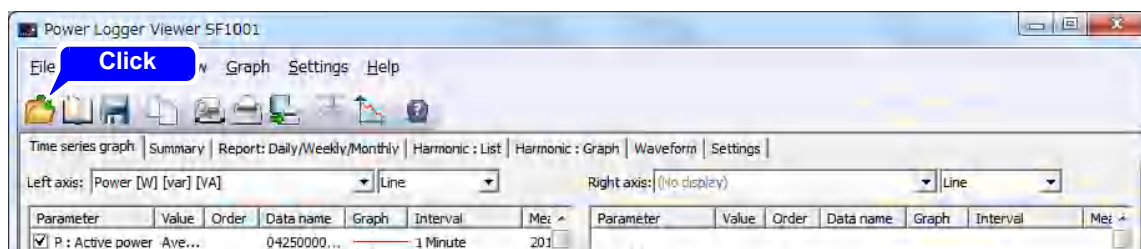

The "Load data file" dialog will appear.

2 Select the number of the data file you wish to change and click **[Change facility capacity]**.

The "Change facility capacity" dialog will appear.

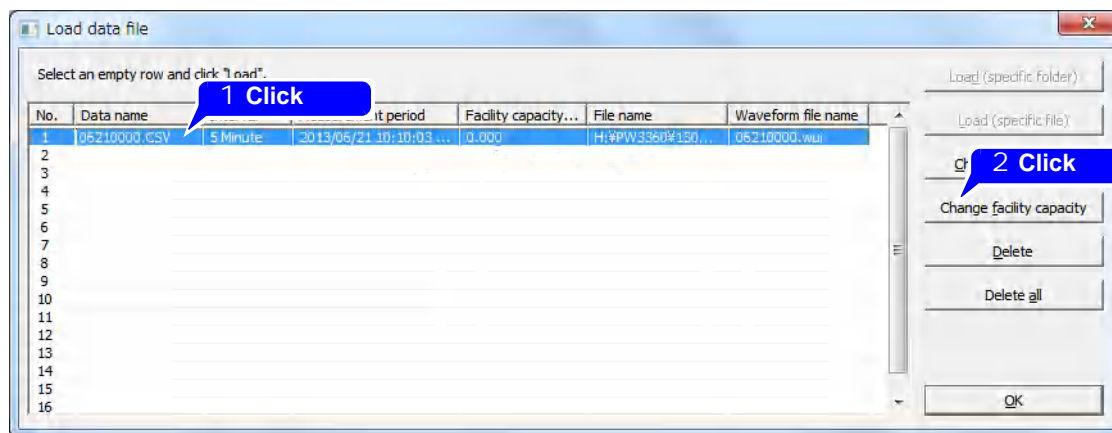

3 Enter a capacity for each circuit, and click **[OK]**.

You will only be able to change the setting for the measurement data circuits.

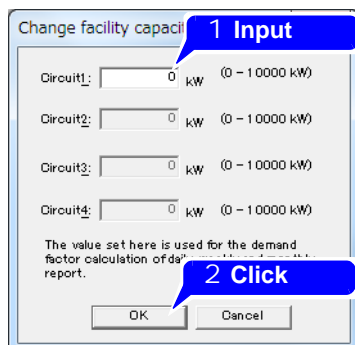

Deleting a Data File from the List

- 1 Click the  button on the tool bar.

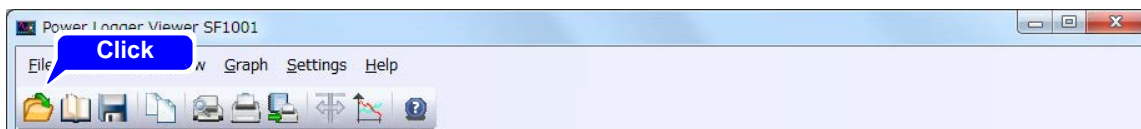

The "Load data file" dialog will appear.

- 2 Select the number of the data file you wish to delete from the list and click **[Delete]**.

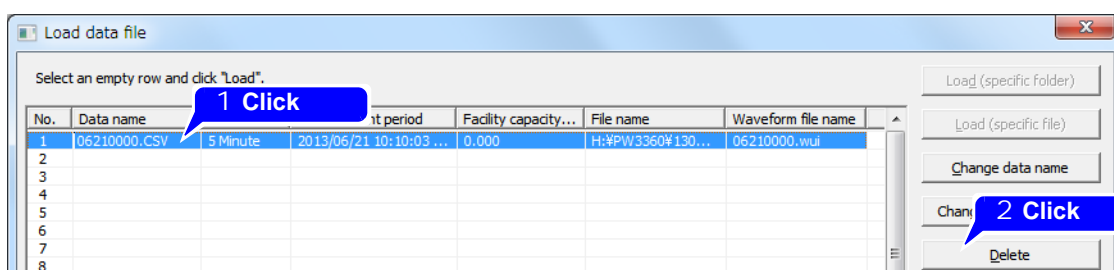

A confirmation message will appear.

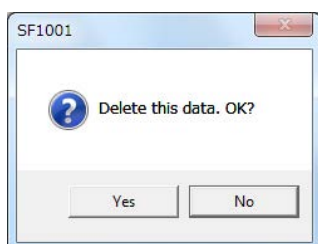

- 3 Click **[Yes]**.
The selected data file from the list will be deleted.

NOTE Loaded data will not be deleted when data files on the list are deleted.

Deleting All Data Files on the Llist

- 1 Click the  button on the tool bar.



The "Load data file" dialog will appear.

- 2 Click **[Delete all]**.

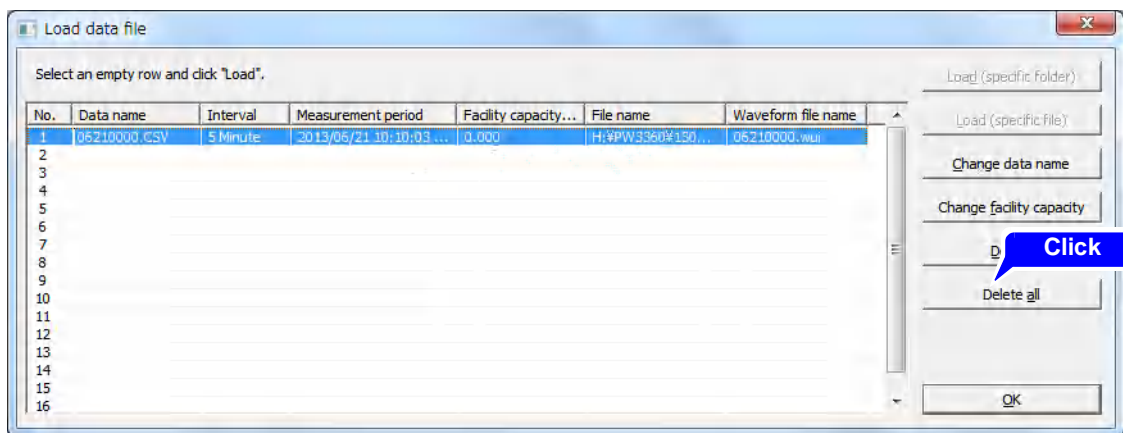

A confirmation message will appear.

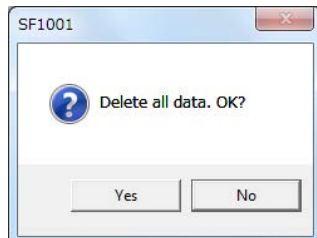

- 3 Click **[Yes]**.
All data files from the list will be deleted.

NOTE Loaded data will not be deleted when data files on the list are deleted.

Loading data logger recorded data

To load data recorded by a data logger with the SF1001 application, it must be opened with the LR5000 utility software and converted.

- 1** Select **[Settings]-[Convert data loggers recorded data]** on the menu bar.

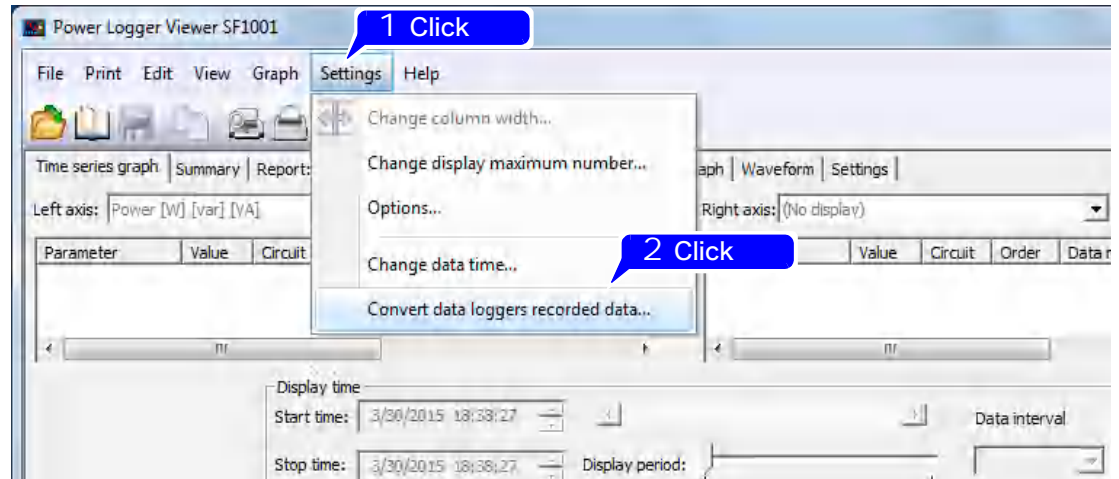

The "Open" dialog will appear.

- 2** Select a data file to be loaded, and click **[Open]**.

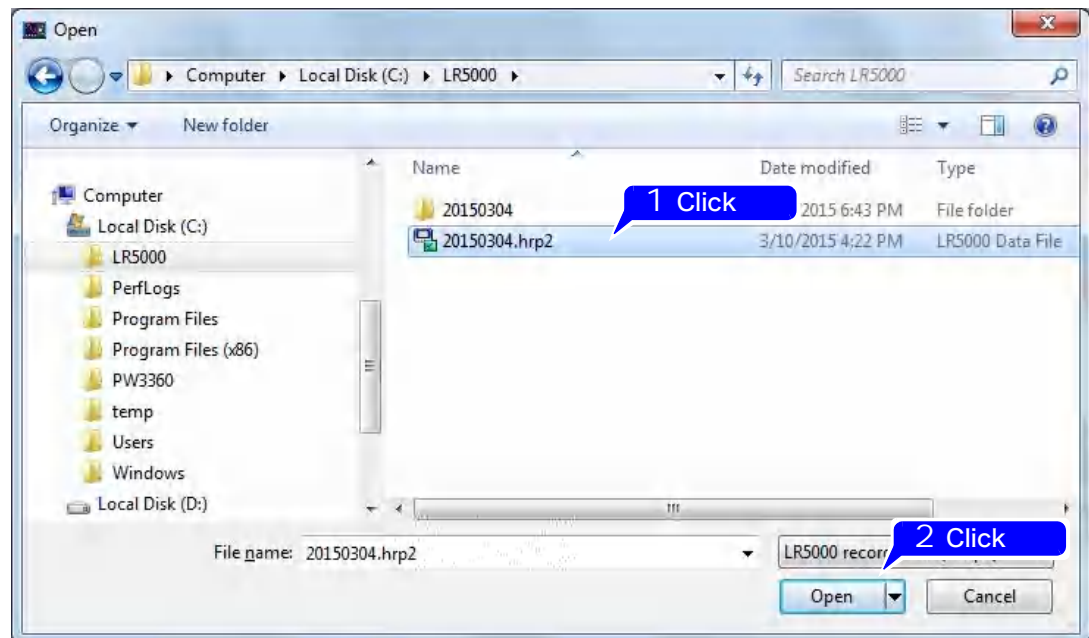

Specify the LR5000 representative file (.hrp2).

- 3 A message will be displayed when the conversion is complete. Click [OK].

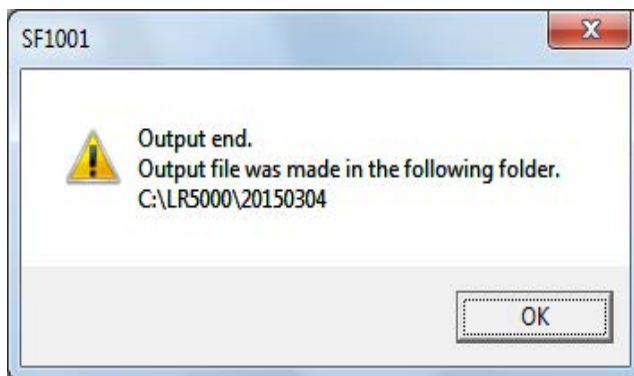

The converted file will be output into a folder with the same name as the LR5000 representative file (.hrp2) located one level lower in the file hierarchy than the original file.

- 4 Load the output file.

For more information about how to load the file, see "Loading Files" (p.12).

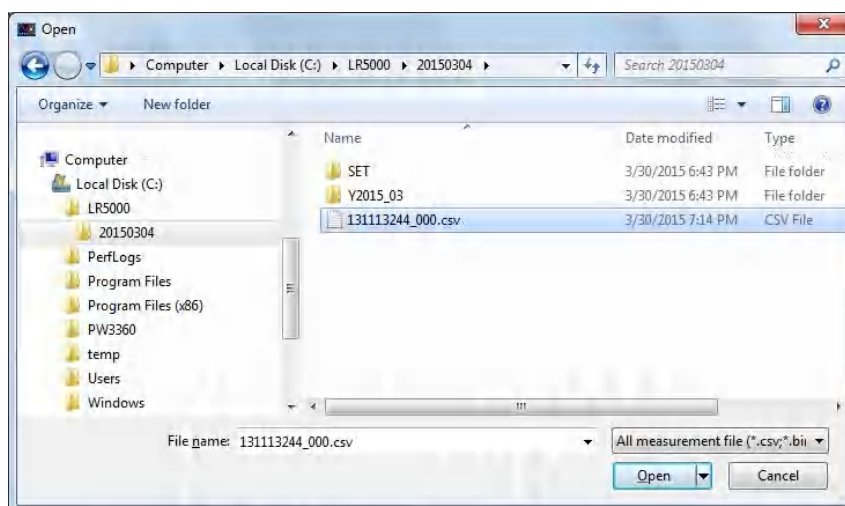

- NOTE** • "If the software is unable to convert the file (for example if the necessary files are not available), an error message will be displayed.

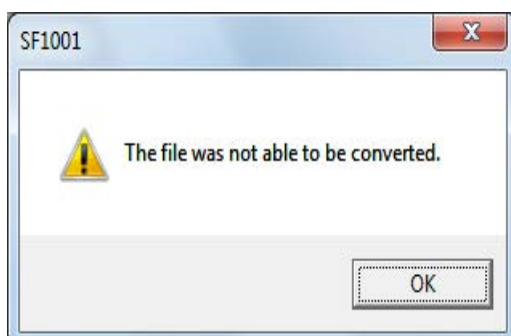

- If the specified LR5000 representative file (.hrp2) contains multiple sets of data recorded by the data logger, each set of data will be output into its own converted file.

2.5 Saving Data in CSV Format

Parameters displayed on the Time-series Graph screen, Summary screen, Daily/Weekly/Monthly Report screen, and Waveform screen as well as data for the displayed time period can be saved as a CSV-format file. Harmonic graph screen, Harmonic list screen, and Settings screen content cannot be saved. Saved CSV files can be used to create reports using commonly available computer spreadsheet programs.

1 Display the screen from which to save data in CSV format.

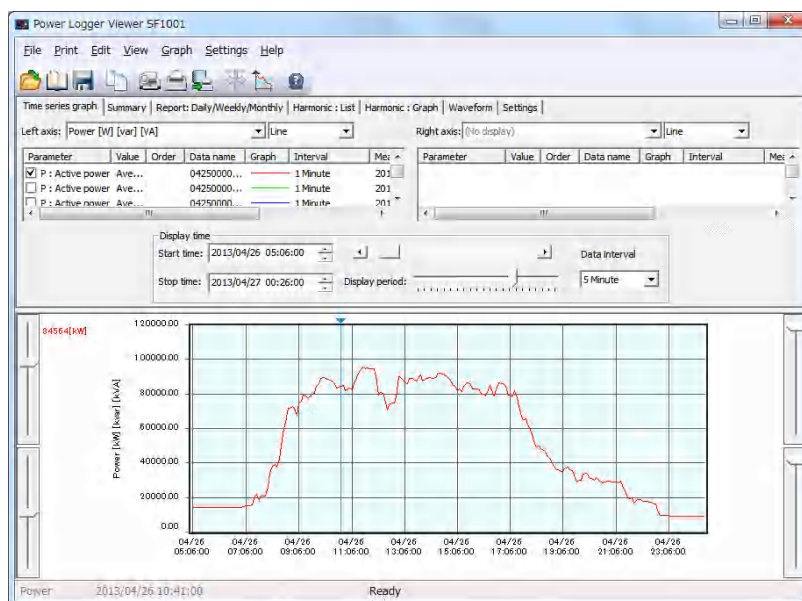

2 Select [File]-[Save csv file] on the menu bar.

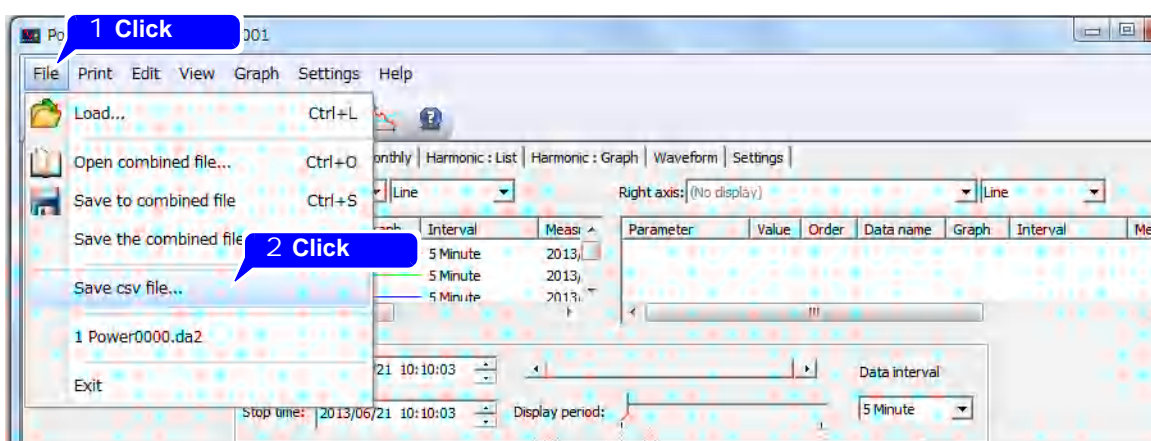

The "Save as CSV file" dialog appears.

3 Enter a filename, and click [Save].

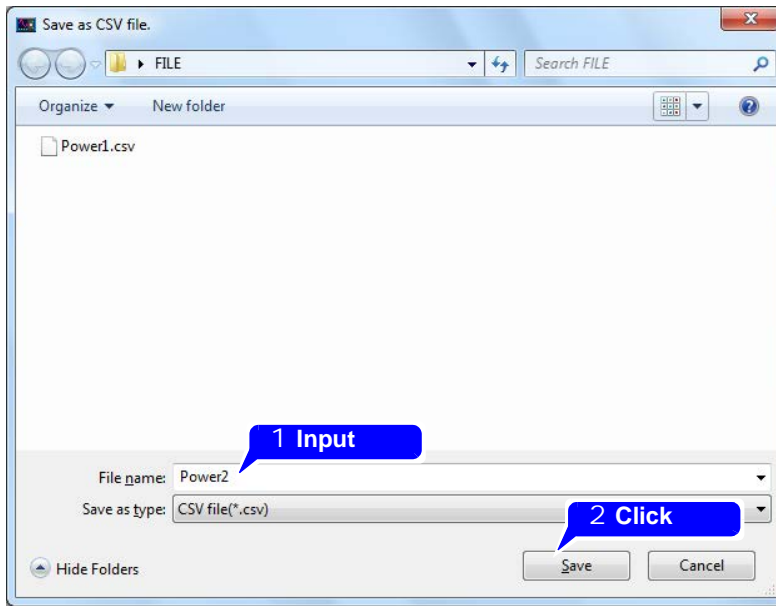

NOTE Data saved as a CSV-format file cannot be loaded by the SF1001 application.

2.6 Saving in a Combined File Under a New File Name

Combine loaded data files into one file, and save the file as a new combined file. (Extension: da2)

What is a combined file?

A combined file is a single file that contains up to 16 sets of PW3360, PW3365, or 3169 measurement data. Data handling can be simplified by combining multiple data files into a single data set stored as a combined file. Additionally, since the size of the data is reduced when it is converted into a combined file, data loading times can be reduced.

1 Select [File]-[Save the combined file as] on the menu bar.

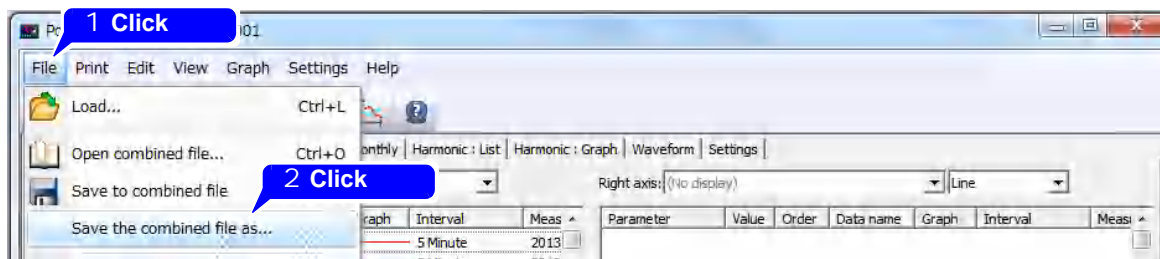

The "Save As" dialog will appear.

2 Enter a filename, and click [Save].

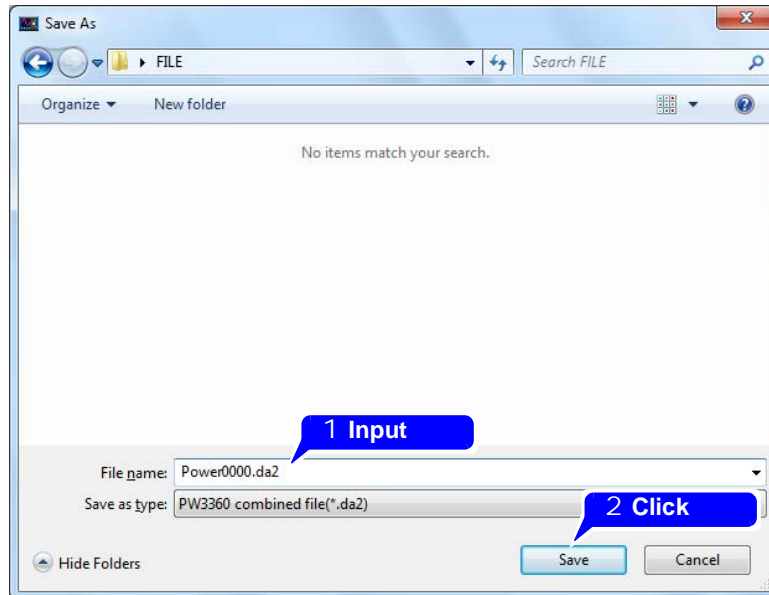

NOTE Maximum data capacity that can be stored in the integrated file is 2GB.

Loading a Combined File

- 1 Click the  on the tool bar.
The “Open” dialog will appear.

- 2 Select a combined file to be loaded, and click [Open].

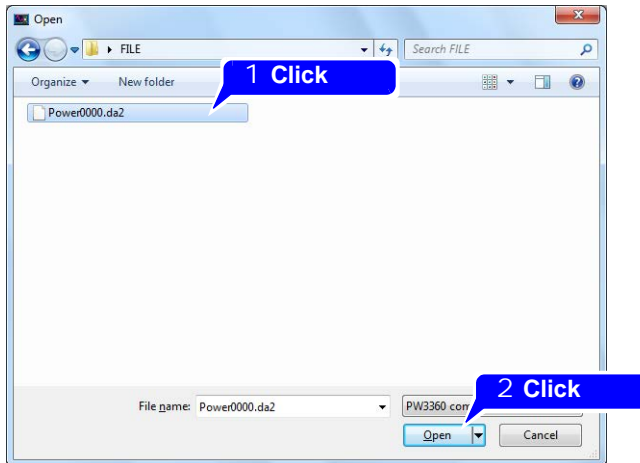

- NOTE**
- When a combined file is loaded, the previously loaded data will be deleted.
 - Multiple combined files cannot be loaded at the same time. To load multiple files, you must load one combined file and then load the remaining data as CSV files.

Saving a Combined File

Click  on the tool bar to save the combined file (by overwriting).

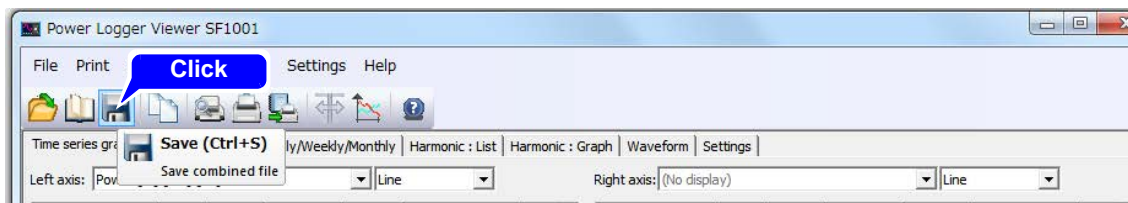

2.7 Settings at Startup of the SF1001

This section describes how to set whether to load the last files in use or revert the application to its default state when launched. By default, neither option is checked. Please set as necessary.

1 Select **[Settings]-[Options]** on the menu bar.

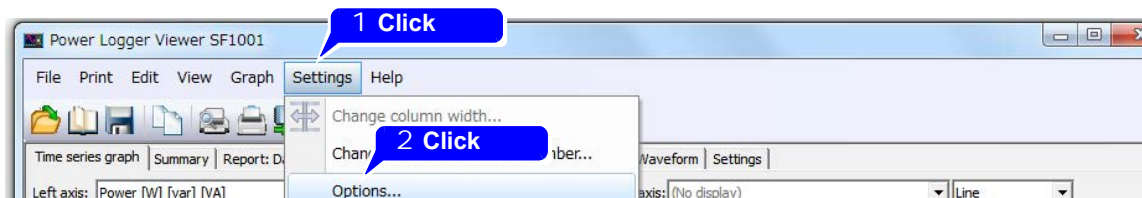

The “Open” dialog will appear.

2 Display the **[Other]** tab and select one of the checkboxes.

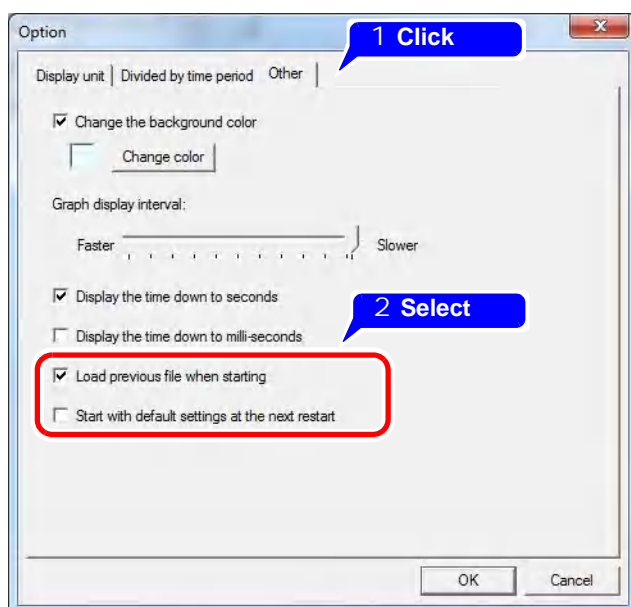

3 Click **[OK]**.

To discard changes, click **[Cancel]**.

- NOTE**
- If “Start with default settings at the next restart” is checked, “Load previous file when starting” is ignored.
 - The “Load previous file when starting” will take effect the next time the application is launched. If the location of the files has changed, nothing will be loaded.
 - The “Start with default settings at the next restart” will only take effect the next time the application is launched.
 - Reverting the application to its default state will have the effect of deselecting both checkboxes.

2.8 Changing the Date of Measurement Data

This section describes how to change the measurement date and time for data saved by the PW3360 or PW3365.

NOTE

- The measurement date and time cannot be changed for measurement data saved by the 3168 or 3169.
- The measurement date and time can be changed for measurement data files and harmonic data files. The measurement date and time cannot be changed for waveform data files.

1

Select **[Settings]-[Change data time]** on the menu bar.

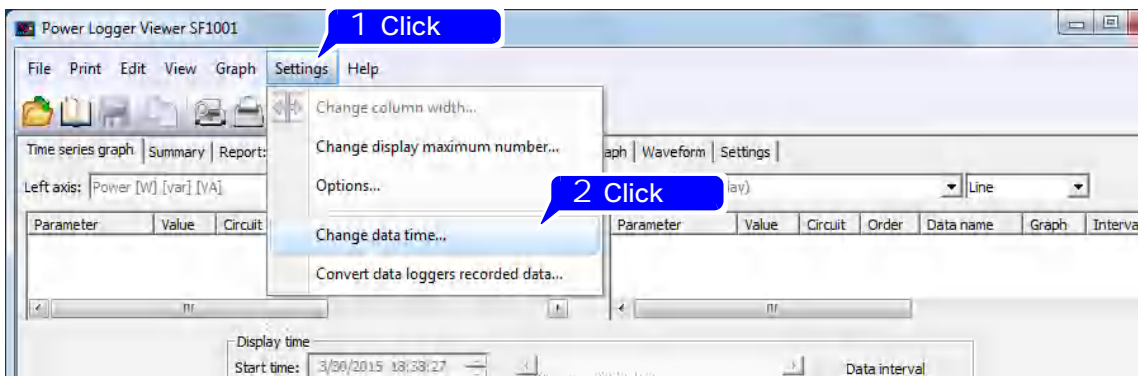

The "Change data time" dialog appears.

2

Click **[Select file]**.

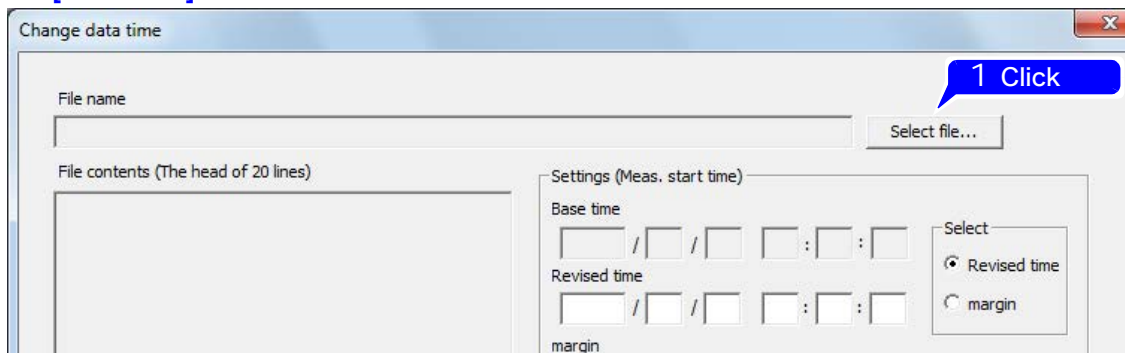

The "Open" dialog appears.

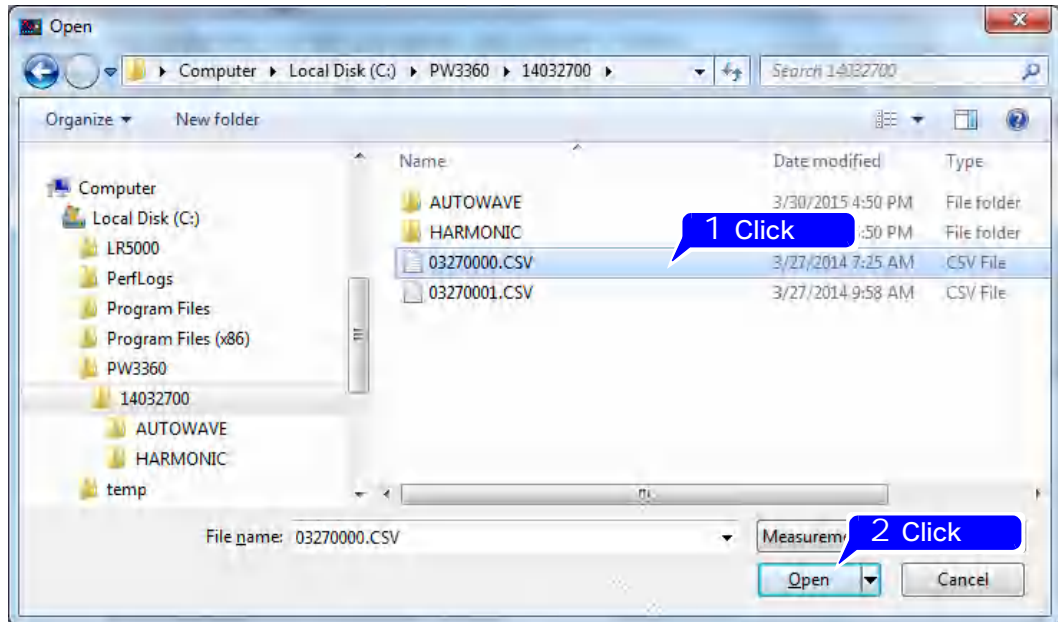
3 Enter a filename, and click [Open].

Specify a measurement data file (.csv).

2.8 Changing the Date of Measurement Data

4 Enter the desired change basis and click **[Make file]**.

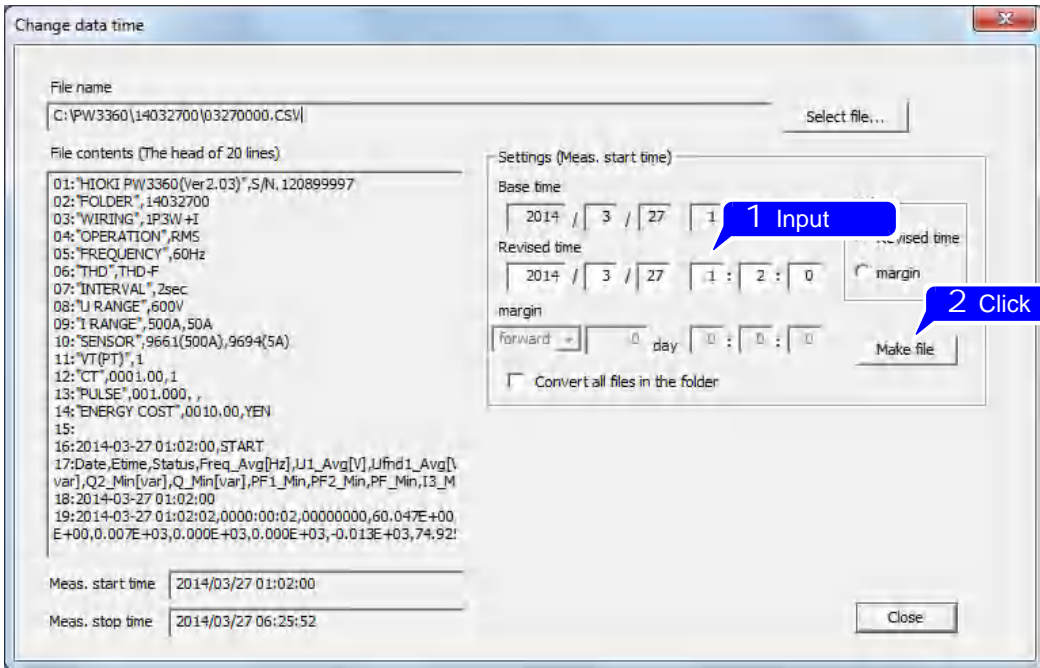

A confirmation message will be displayed.

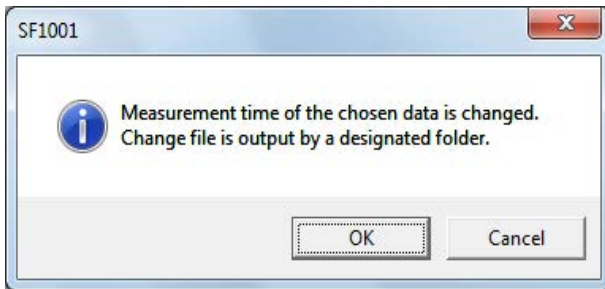

5 Click **[OK]** to start converting the file.

A message will be displayed while the file is being converted.

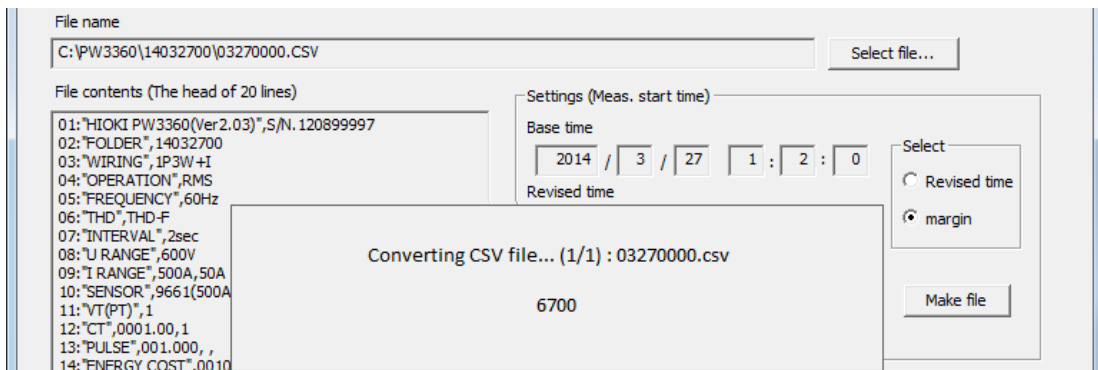

If there is a harmonic data file (.hrm) corresponding to the measurement data file (.csv) that you selected, it will be converted as well.

6

A message will be displayed when the conversion is complete. Click **[OK]**.

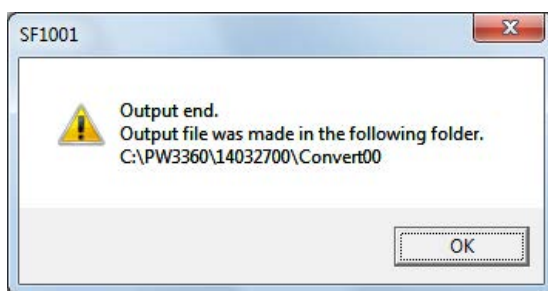

The converted file will be output into a new folder created with the name "ConvertXX" (where XX indicates an automatically allocated value from 00 to 99) in the same folder as the specified measurement data file (.csv).

NOTE • A warning message will be displayed if you attempt to load a file other than a measurement data file from the PW3360 or PW3365.

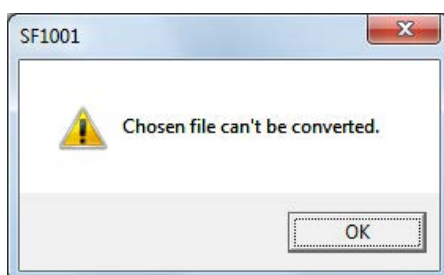

• Specify either "Revised time" or "margin" as the change basis.

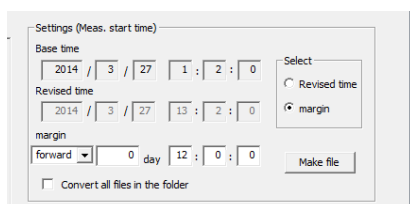
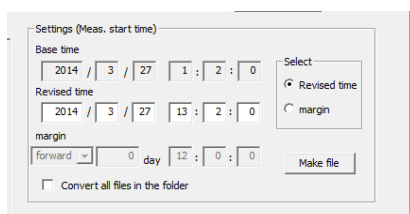

• To convert all measurement data files in the folder in which the specified measurement data file is located, select the **[Convert files in folder]** checkbox and click **[Make file]**.

Convert all files in the folder

Screen Configuration Chapter 3

3.1 Screens

The SF1001 application consists of seven screens. Click the tabs on the main screen to switch among the screens.

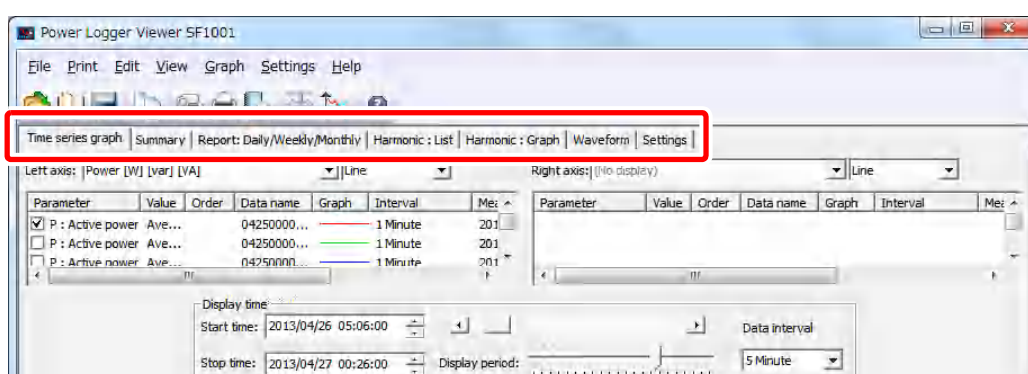

Screen name	Contents	For more information
Time-series Graph Screen	Displays a time-series graph of selected data	"Chapter 4 Displaying a Time-series Graph" (p.35)
Summary Screen	Displays a list of selected data	"Chapter 5 Displaying Summary" (p.49)
Daily, Weekly, and Monthly report Screen	Displays a daily, weekly, or monthly report of demand data	"Chapter 6 Displaying the Report: Daily/ Weekly/ Monthly" (p.59)
Harmonic List Screen	Displays a list of harmonic measurement data	"Chapter 7 Displaying a Harmonic List" (p.73)
Harmonic Graphic Screen	Displays a graph of harmonic measurement data	"Chapter 8 Displaying a Harmonic Graph" (p.79)
Waveform Screen	Displays a graph of waveform data	"Chapter 9 Displaying Measurement Data Waveforms" (p.87)
Setting Screen	Displays major setting information	"Chapter 10 Displaying Settings for Measurement Data" (p.95)

3.2 Common Interface Elements and Functionality

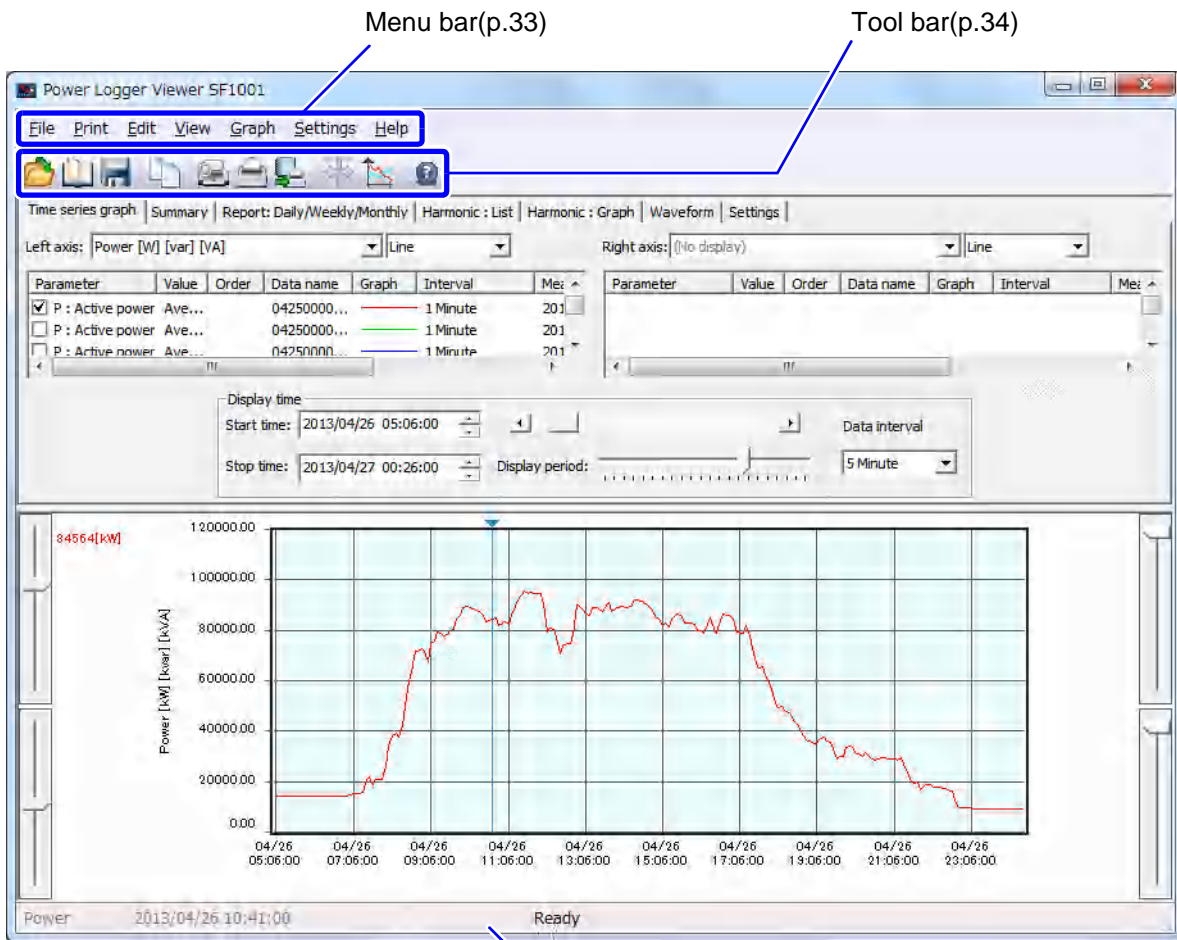

Menu bar(p.33)

Tool bar(p.34)

Status bar

Displays the time during cursor measurement, explanations of the menu bar or tool bar, and the "Loading" message.

Menu Bar

The menu bar has the following menu options.

	Menu	Contents
File	Load	Load a data file.
	Open combined file	Open a combined file.
	Save to combined file	Save a combined file.
	Save the combined file as	Save in a combined file under a new filename.
	Save csv file	Save the data of the displayed measurement item in CSV format.
	Recently opened combined file	Display a list of the combined files worked on last.
	Exit	Exit the SF1001.
Print	Print	Print the currently displayed screen.
	Print preview	Display a print preview of the currently displayed screen.
	Report printing	Print a report for the set period of time.
	Header settings	Set the logo and title to use when printing reports as well as the comments to display.
	Printer settings	Configure printer settings.
Edit	Copy	Copy the currently displayed screen to the clipboard.
View	Toolbars	Set whether to display the tool bar.
	Tool button	Change the button size and set whether to display button labels.
Graph	Change vertical axis settings	Display the "Vertical axis setting" dialog for a graph.
Settings	Change column width	Change the column width in the list display.
	Change display maximum number	Change the maximum number of display items.
	Options	Display the "Options" dialog box for setting the display units, and other parameters (background color for graphs, rendering interval, and startup state).
	Change data time	Change the data's measurement date and time.
	Convert data logger recorded data	Convert and output data recorded by a data logger so that it can be opened by the SF1001 application.
Help	About	Display version information.
	Open help file	Open the user manual.

Toolbar

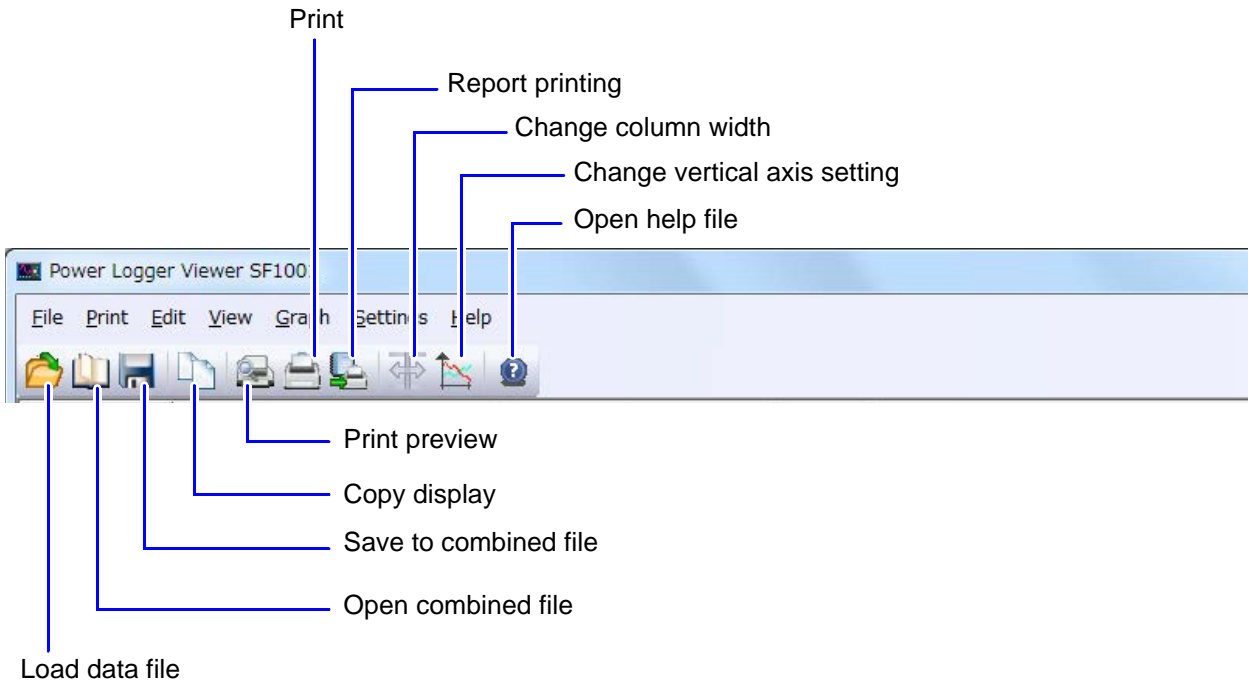

Pasting to the Clipboard

Click the  button, or select **[Edit]-[Copy]** on the menu bar.

The currently displayed screen can be pasted to the clipboard and worked on using another program, such as a word-processing program.

Displaying a Time-series Graph

Chapter 4

Display a time-series graph of selected data. Click the “Time-series graph” tab to display.

Selection of data parameter shown on left axis of graph (p.36)

Selection of data parameter shown on right axis of graph (p.36)

Graph type selection (p.36)

Graph type selection (p.36)

Click

Detail item selection (p.37)

Display start/stop time setting (p.40)

Vertical-axis upper-limit slider (left)

Vertical-axis lower-limit slider (left)

Cursor measurement value(p.43)

Cursor-indicated time

Cursor (p.43)

Display-range scrolling(p.41)

Display-period setting(p.42)

Data-interval setting(p.39)

Vertical-axis upper-limit slider (right)

Cursor measurement value(p.43)

Vertical-axis lower-limit slider (right)

Parameter	Value	Order	Data name	Graph	Interval	Meas
P : Active power	Ave...	04250000...	1 Minute	201		
P : Active power	Ave...	04250000...	1 Minute	201		
P : Active power	Ave...	04250000...	1 Minute	201		

Parameter	Value	Order	Data name	Graph	Interval	Meas
U1 : Voltage	Ave...	04250000...	1 Minute	2013...		
U1 : Voltage	Ave...	04250000...	1 Minute	2013...		
U1 : Voltage	Ave...	04250000...	1 Minute	2013...		

4.1 Select Data Items and Graph type to Display

Select a data item for each of the left and right axes of the graph.
 Select a graph type (line, bar, and stacked bar graphs) for each axis.
 Stacked bar graphs are available for demand and demand value (excluding the power factor) only.

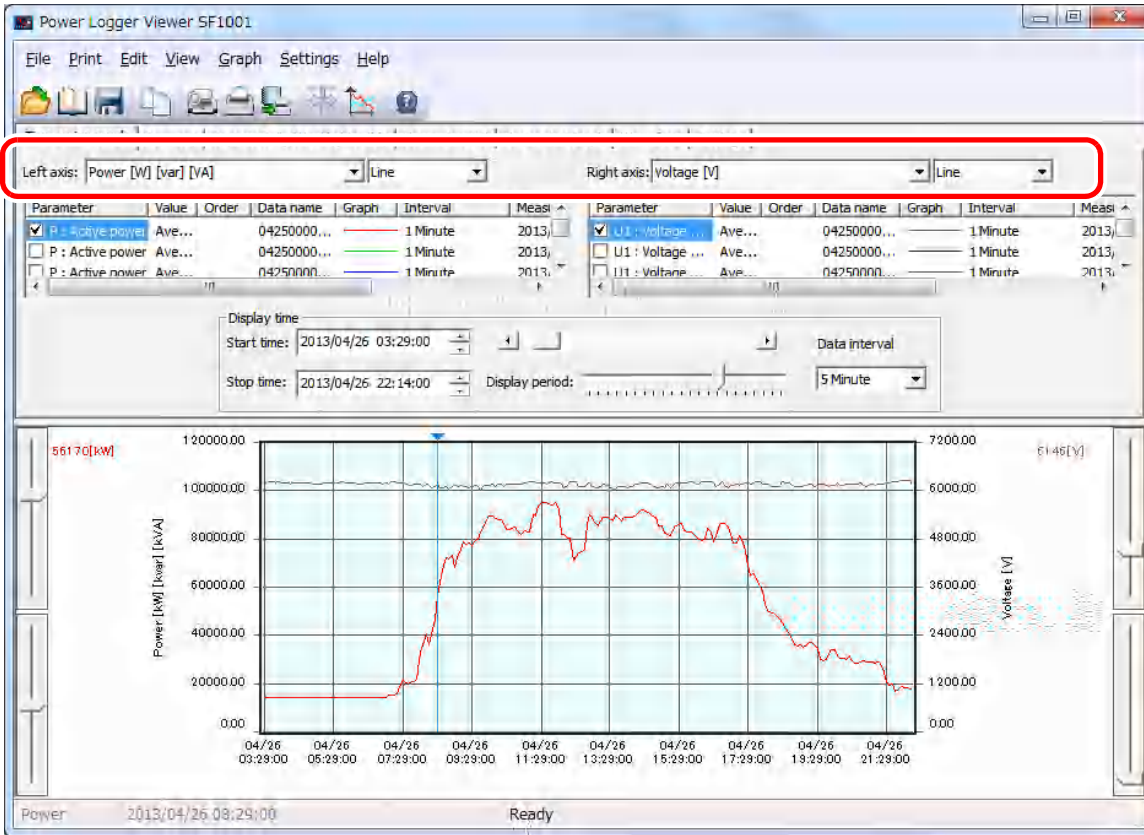

4.2 Select Detail Items

Select the checkbox for the items you wish to graph.

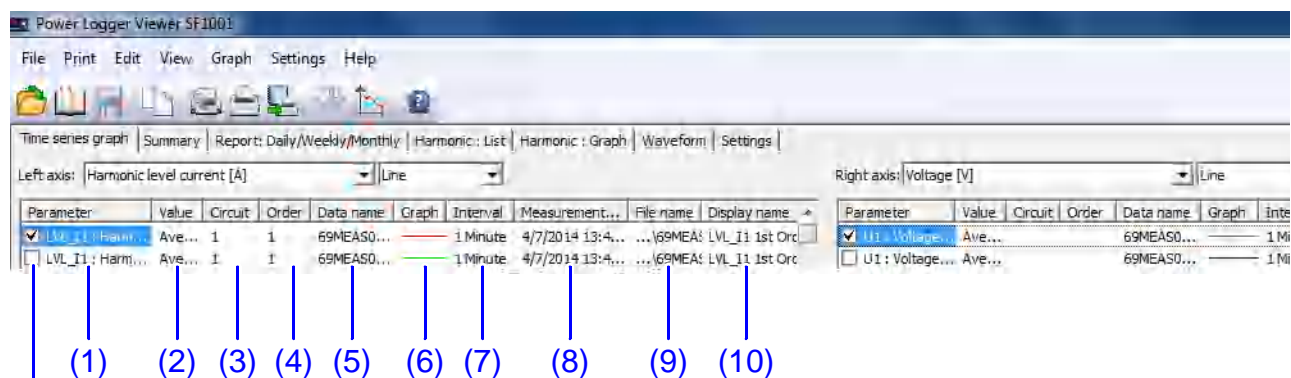

Check boxes

(1) Parameter

Check the box of each item to be displayed.

Click (1) on the parameter of an item, and a list of selectable parameters will appear. Select an item to display from the list.

(2) Value

Click (2) on the value of an item, and a list of selectable data types (instantaneous, average, maximum, and minimum) will appear. Select a data type from the list.

If the loaded data contains only average values, you will only be able to select average values as the data type. You will not be able to select electrical energy, demand quantity, demand value, pulse input value, or electricity charges.

(3) Circuit

Click (3), and the selectable circuit numbers will be displayed. Select a circuit number to be displayed.

(4) Order

Click (4) on the value of an item, and a list of selectable harmonic data degree will appear. Select the order to display.

(5) Data name

Click (5) on the data name, and a list of selectable data names will appear. Select the name of the data to be displayed.

4.2 Select Detail Items

(6) Graph

Click (6) on the graph, and the “Change graph format” dialog will appear. This box allows the line color, line style, line width, frame of bar graph, marker color, marker type, and marker size to be set. Line styles can be changed only when line width is set to 1.

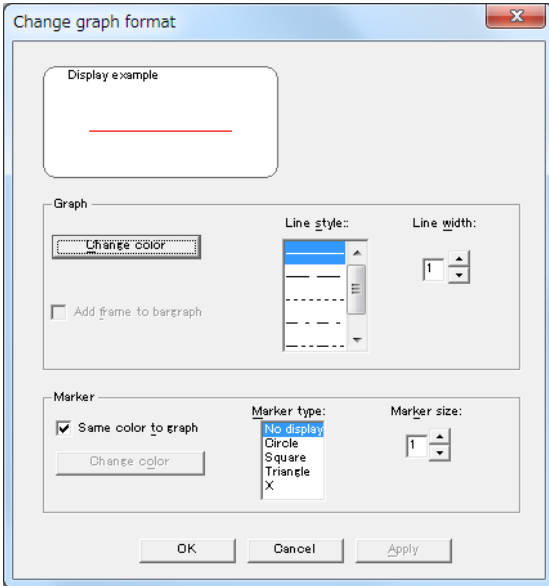

(7) Interval

Display the measurement interval of the data to be loaded.

(8) Measurement period

Display the measurement period of the data to be loaded.

(9) File name

Display the file name of the data to be loaded.

(10) Display name

Set the name of each display item to be used in printout. Click (10) on the display name, and the “Display name” dialog will appear. The display name setting applies to time-series graph screen copies and when printing.

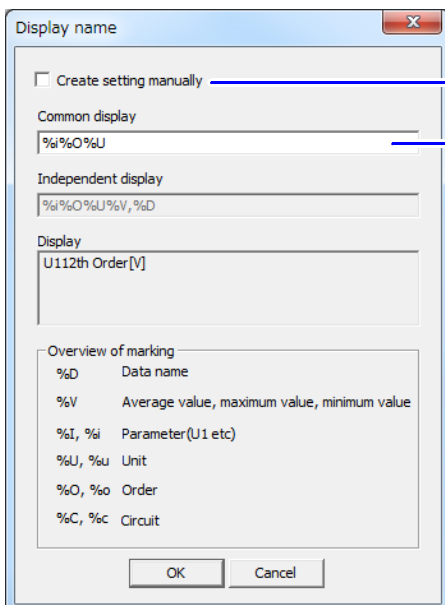

Check to set the display name of each item separately.

Select and enter a symbol from the symbol list. You may also enter any desired character.

4.3 Set Data Interval for the Displayed Data

This section describes how to set the data interval to determine the interval time for the data being displayed.

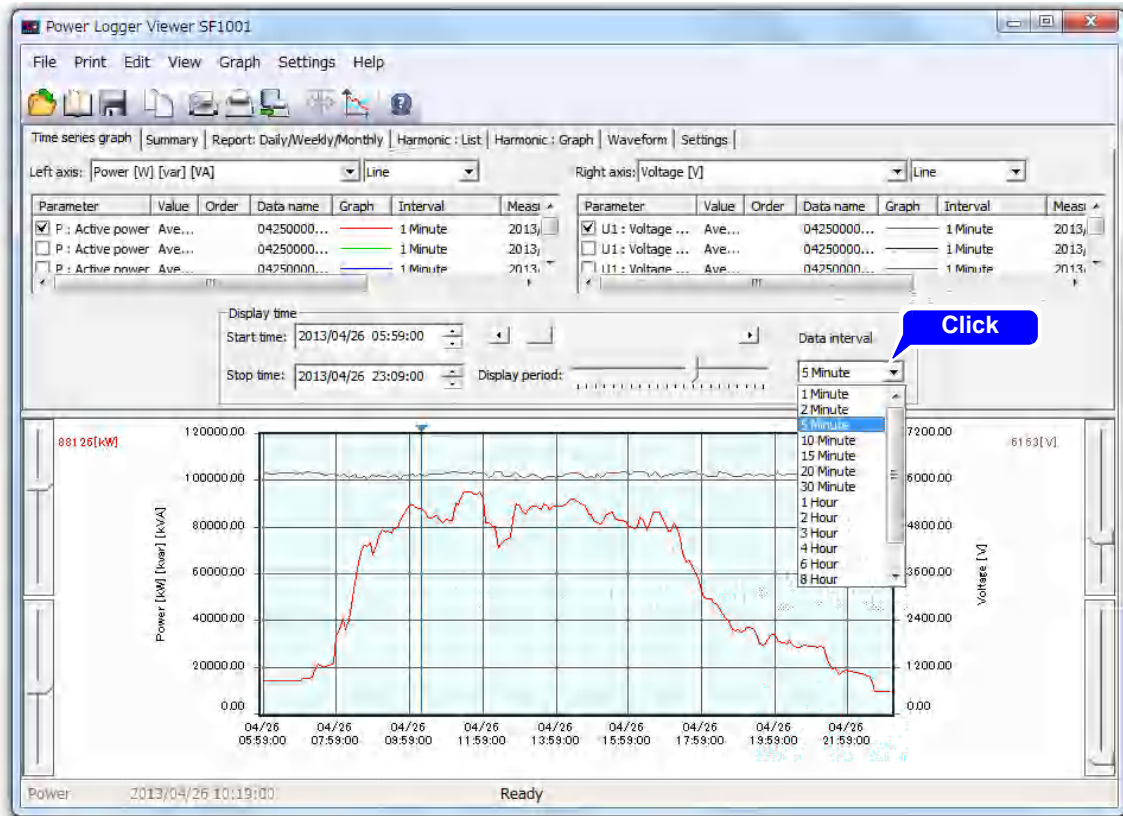

NOTE

- An interval smaller than the interval of the loaded data cannot be set.
- When multiple pieces of data have been loaded, a larger interval will be used.
- If the data interval is set to other than an integral multiple of the measurement interval, the display may not show the actual data.

4.4 Setting the Graph Display Start and End Time and Date

This section describes how to set the start and end times for the graph display.

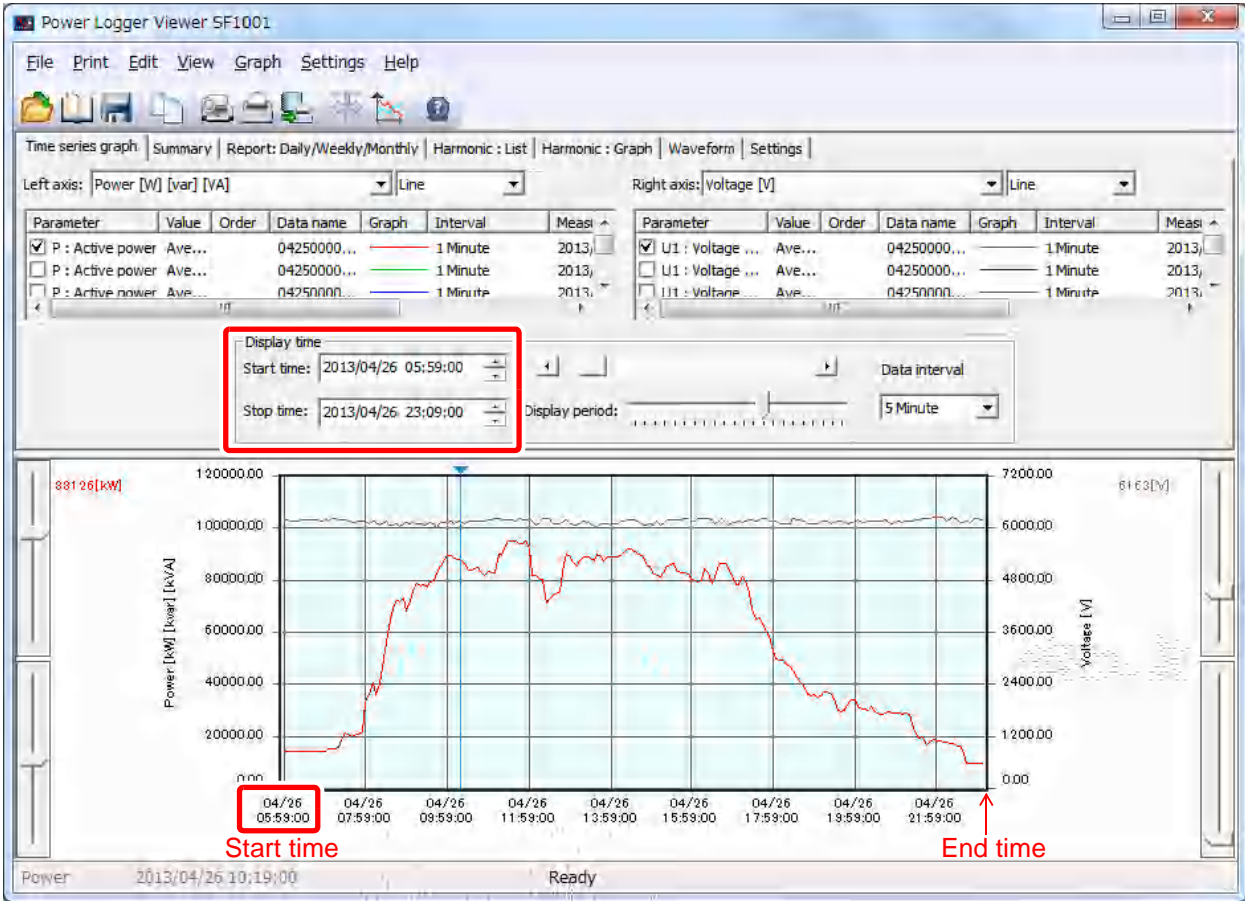

NOTE If the display start time is set to a time other than (measurement start time + the displayed time) will differ from the actual time. Thus, measurements made immediately before the displayed time of each interval will be displayed as made at the actual time.

4.5 Move Display Range

The display range may be changed by moving the scroll bar.

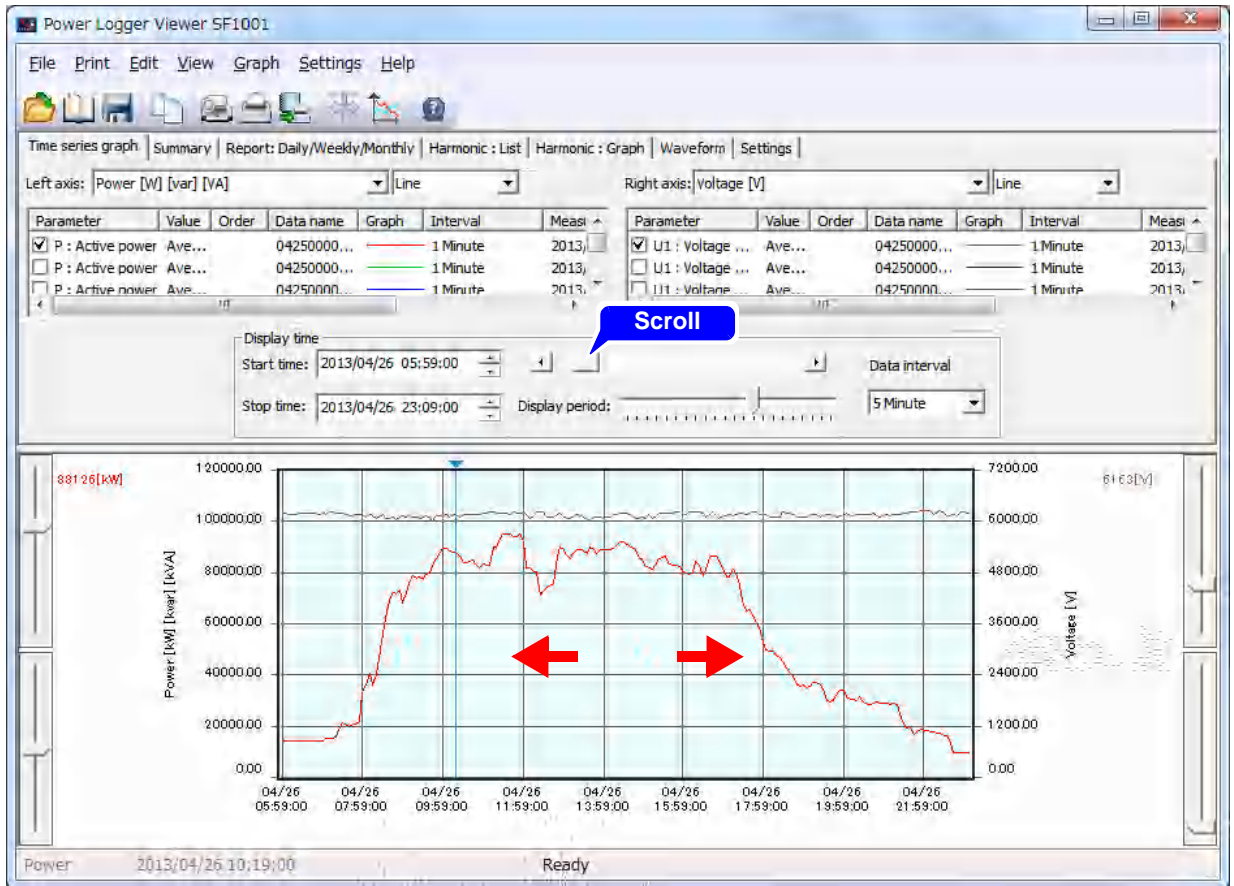

NOTE If the graph renders slowly, change the graph rendering interval under **[Option]-[Other]-[Graph display interval]**.

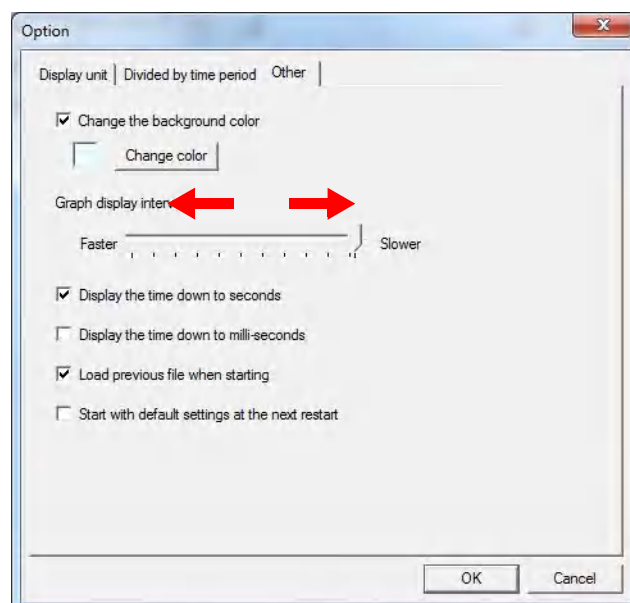

4.6 Set Display Period

The display period may be changed by moving the slider.

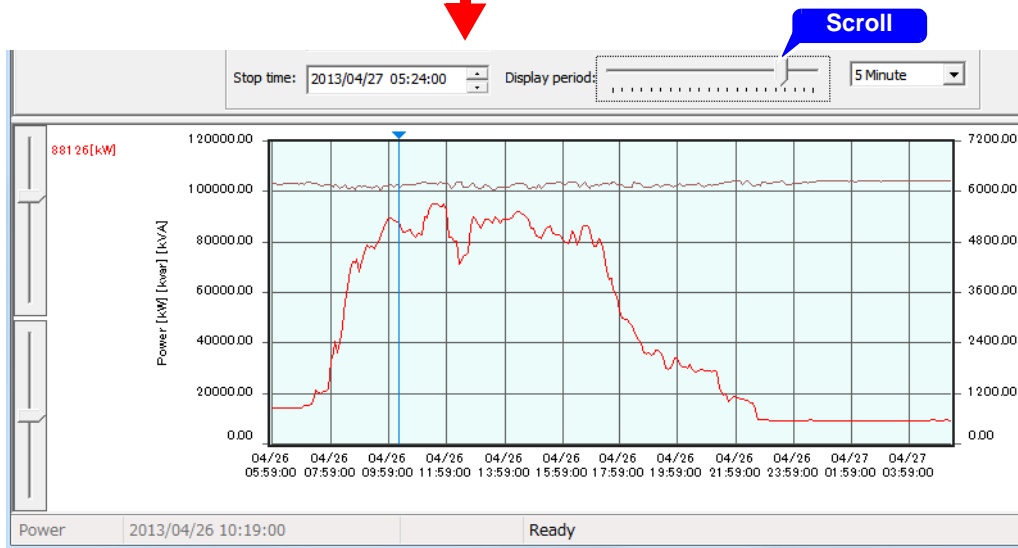
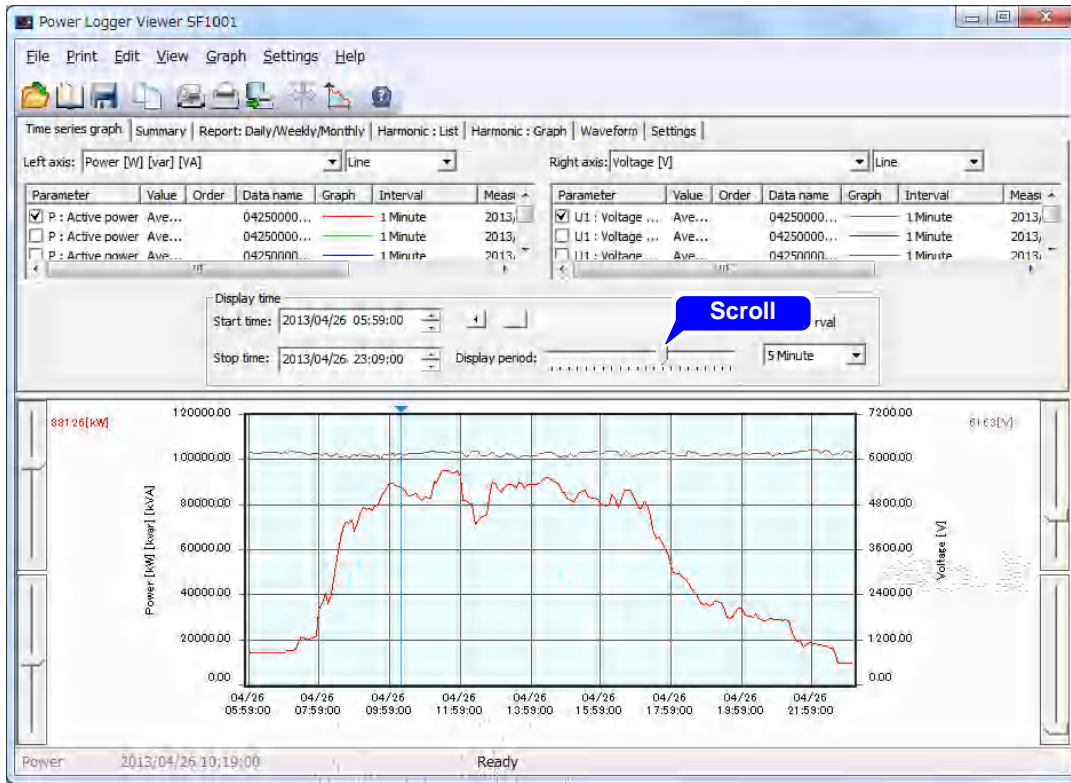

NOTE

- The maximum number of graph data points that can be displayed on a single screen can be changed under [\[Settings\]-\[Change display maximum number\]](#). See: "4.9 Changing the Maximum Number of Display Items" (p.45)
- The data interval, display times, and display period are linked to the Summary screen settings.
- Up to 10,000 data points can be displayed on the graph. Depending on the maximum number of display items and data interval settings, it may not be possible to simultaneously display the graph start and end times.

4.7 Displaying the Value at the Cursor Position

Click in the graph display area, and the cursor will appear. The measurement of the point at which the cursor is located will be displayed. The cursor can also be moved using the ← and → keys on the keyboard. To hide the cursor, click anywhere outside the graph display area.

Measured value
at cursor position
(left axis)

Measured value
at cursor position
(right axis)

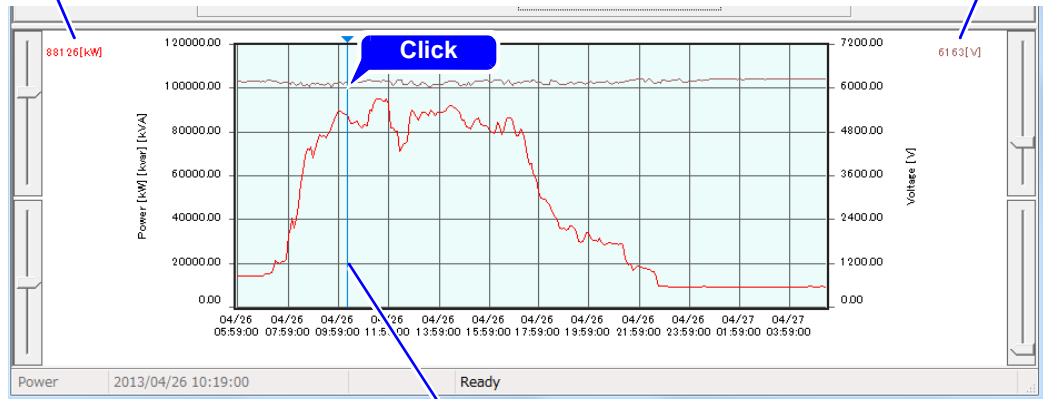

Cursor

4.8 Set Vertical Axis

- 1 Click the  on the tool bar.

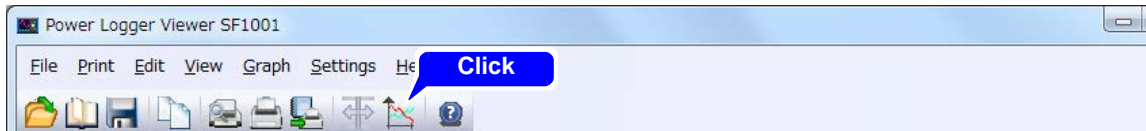

The “Vertical axis settings” dialog will appear.

- 2 Set the vertical axis.

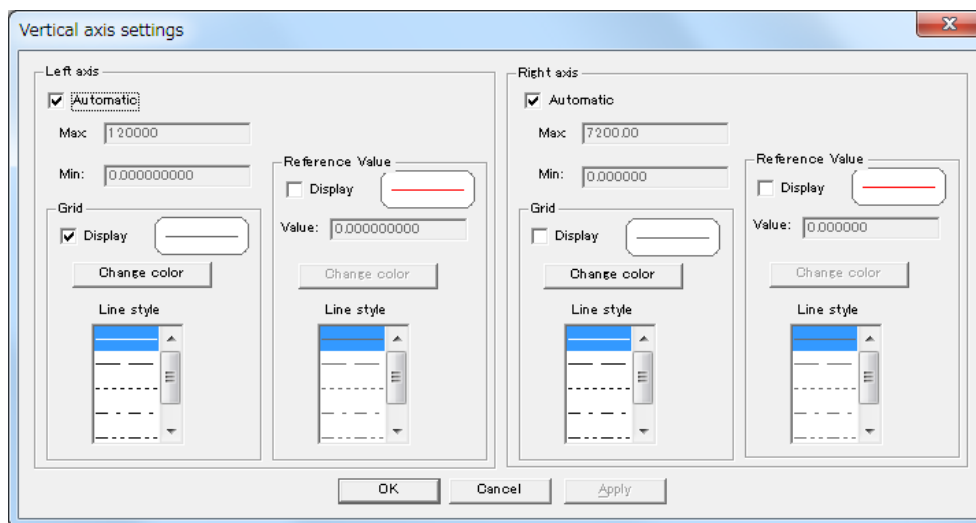

- 3 Click the [OK].

Parameters	Description
Left axis, Right axis	Changes the upper limit value (Max) and lower limit value (Min) for the vertical axis. (These values are usually set automatically.) The values can also be changed using the vertical slider.
Grid	Show or hide the grid line. Set the color and line style.
Reference Value	Show or hide the reference value. Set the value, color, and line style.

NOTE The grid color of the time axis is determined by the grid color of the left axis.

4.9 Changing the Maximum Number of Display Items

Set the maximum displayable number of items along the time axis.

- 1 Select **[Settings]-[Change display maximum number]** on the menu bar.

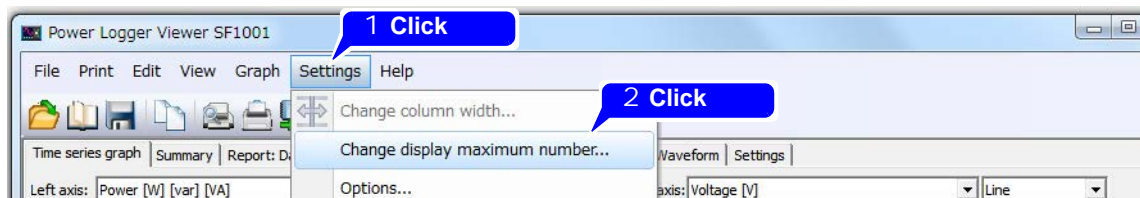

The “Display maximum number” dialog will appear.

- 2 Set the maximum number of display items on the graph as necessary.

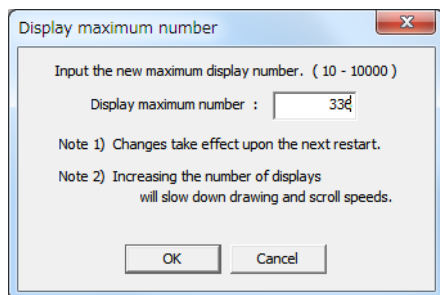

This setting will also be applied to the number of Summary display items.

- 3 Click the **[OK]**.

NOTE

- The setting will take effect the next time the application is launched.
- By default, 336 data points (7 days' of data with a 30 min. recording interval) are shown.

4.10 Change Display Unit

- 1 Select **[Settings]-[Options]** on the menu bar.



- 2 Deselect the **[Display by the number of digits in default setting.]** checkbox on the “Display unit” tab.

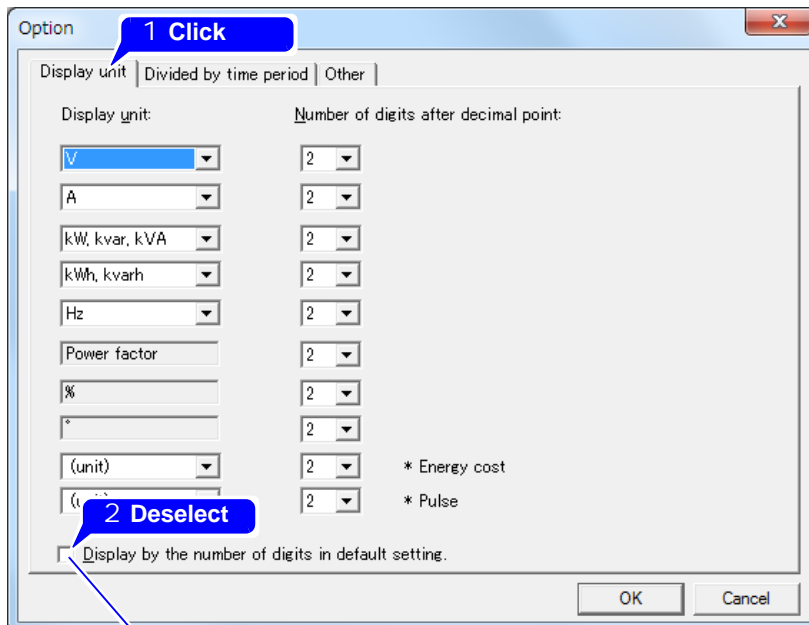

Selecting this checkbox causes data to be displayed using the number of measurement data digits, without regard to the number of decimal places setting.

- 3 Set the display unit for measurement value, and the number of decimals

- 4 Click the **[OK]**.

4.11 Change Background Color

- 1 Select **[Settings]-[Options]** on the menu bar.



- 2 Check the “Change the background color” box and click the **[Change color]**.

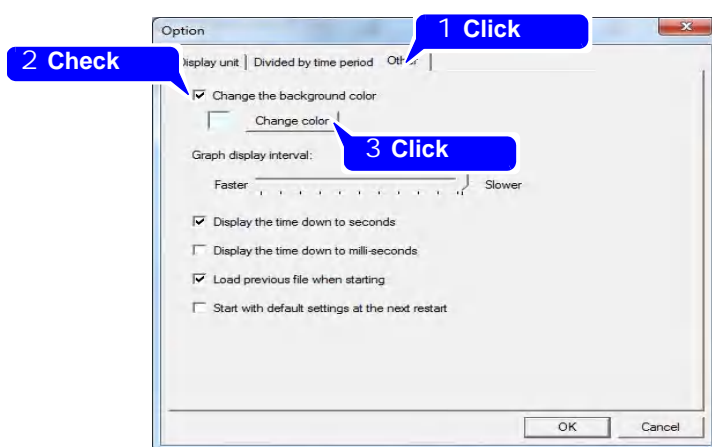

The “Color” dialog will appear.

- 3 Select a background color.

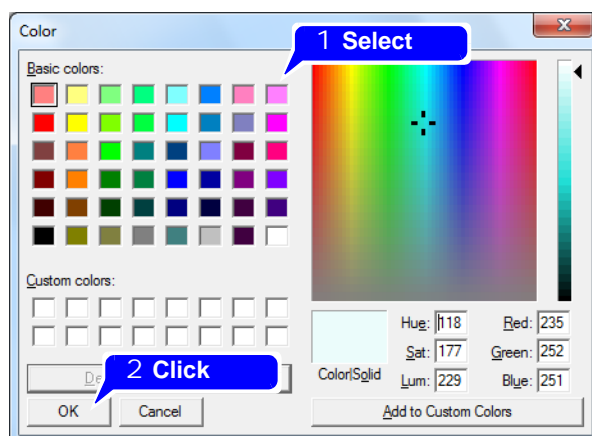

- 4 Click the **[OK]**.

- NOTE**
- The graph background color applies only to the SF1001 graph display and screen copies.
 - White is used as the graph background color during screen and report printing.

4.12 Set time display down to seconds or lower digit

Set whether to display the time down to seconds and milliseconds.
 Configure this setting as appropriate.
 The setting also applies to the time displays in the daily, weekly, and monthly reports.

1 Select [Settings]-[Options] on the menu bar.



2 Display the [Other] tab and select the [Display the time down to seconds] checkbox.

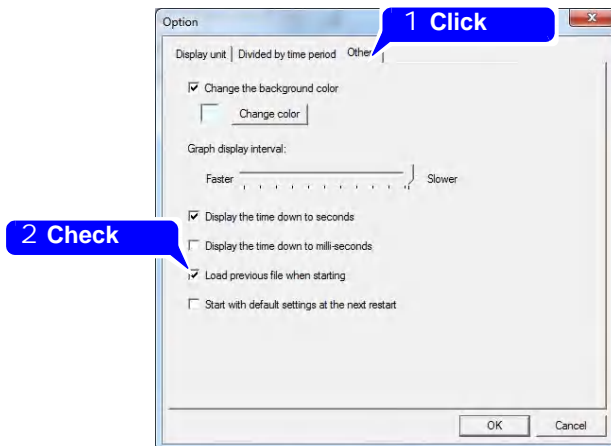

3 Click [OK]. To discard changes, click [Cancel].

NOTE When the data saved with Model 3196 with the short-term interval set to “Full wave” are displayed with the data interval set to “Full wave”, they are displayed down to not milliseconds but seconds.

Displaying Summary

Chapter 5

Display a list of numerical values of selected data. Click the “Summary” tab to display.

Click

Detail item selection (p.50)

Display date and time setting (p.53)

Display-range scrolling (p.54)

Display-period setting (p.55)

Data-interval setting (p.52)

Screen scrolling (p.56)

Screen scrolling(p.56)

Date	Time	LVL_P 1st Order[kW]	LVL_P 3rd Order[kW]	LVL[V]	I1[A]	I2[A]	I1[A]	I2[A]	P[kW]	Q[kvar]	S[kVA]
Average value in this period											
		1.6616	-0.0143	110016	13.716	13.715	274.217	275.817	1.6243	0.0001	1.6243
Maximum value in this period											
		1.7306	-0.0131	110183	14.345	14.344	286.200	286.200	1.7081	0.0002	1.7081
Time of maximum value											
	4/15/2014	4/15/2014	4/15/2014	4/15/2014	4/15/2014	4/15/2014	4/15/2014	4/15/2014	4/15/2014	4/15/2014	4/15/2014
	16:47:00	16:47:00	17:17:00	16:47:00	16:47:00	16:47:00	16:47:00	16:47:00	16:47:00	16:47:00	16:47:00
Minimum value in this period											
		1.6133	-0.0158	99.51	13.161	13.160	263.100	263.500	1.5765	0.0000	1.5765
Time of minimum value											
	4/15/2014	4/15/2014	4/15/2014	4/15/2014	4/15/2014	4/15/2014	4/15/2014	4/15/2014	4/15/2014	4/15/2014	4/15/2014
	17:47:00	16:47:00	16:47:00	16:47:00	17:17:00	17:17:00	17:17:00	17:17:00	17:47:00	16:47:00	17:47:00
4/15/2014	14:47:00										
	15:17:00	1.7070	-0.0137	110033	14.145	14.144	282.800	282.200	1.6715	0.0009	1.6715
	16:47:00	1.6140	-0.0131	99.50	13.338	13.337	266.200	266.100	1.5751	0.0001	1.5751
	15:17:00	1.6575	-0.0133	99.51	13.357	13.356	277.300	278.500	1.6310	0.0001	1.6310
	16:47:00	1.7505	-0.0158	100115	14.345	14.344	286.200	286.200	1.7081	0.0000	1.7081
	17:17:00	1.6174	-0.0143	10153	13.161	13.160	263.100	263.500	1.5788	0.0002	1.5788
	17:47:00	1.6133	-0.0148	99.58	13.340	13.341	266.200	266.100	1.5765	0.0001	1.5765

NOTE Invalid data is displayed as a blank.

5.1 Select Data Items to Display

Choose up to 16 data items to display and select their checkboxes.

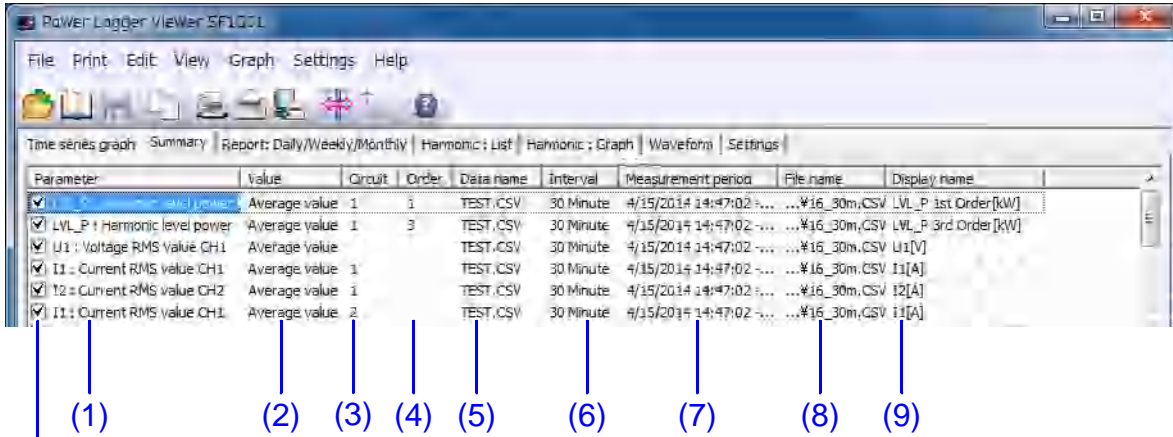

Check boxes

(1) Parameters

Check the box of each item to be displayed.

Click (1) on the parameter of an item, and a list of selectable parameters will appear. Select an item to display from the list.

(2) Value

Click (2) on the value of an item, and a list of selectable data types (instantaneous, average, maximum, and minimum) will appear. Select a data type from the list.

If the loaded data contains only average values, you will only be able to select average values as the data type. You will not be able to select electrical energy, demand quantity, demand value, pulse input value, or electricity charges.

(3) Circuit

Click (3), and the selectable circuit numbers will be displayed. Select a circuit number to be displayed.

(4) Order

Click (4) on the value of an item, and a list of selectable harmonic data degree will appear. Select the order to display.

(5) Data name

Click (5) on the data name, and a list of selectable data names will appear. Select the name of the data to be displayed.

(6) Interval

Display the measurement interval of the data to be loaded.

(7) Measurement period

Display the measurement period of the data to be loaded.

(8) File name

Display the file name of the data to be loaded.

(9) Display name

Set the name of each display item to be used in printout.

Click (9) on the display name, and the "Display name" dialog will appear.

The display name setting applies to time-series graph screen copies and when printing.

Display name

Create setting manually

Common display
%d%u

Independent display
%d%u%v,%d

Display
U112th Order[V]

Overview of marking

%d	Data name
%v	Average value, maximum value, minimum value
%t, %i	Parameter (U1 etc)
%u, %u	Unit
%o, %o	Order
%c, %c	Circuit

OK Cancel

Check to set the display name of each item separately.

Select and enter a symbol from the symbol list.
You may also enter any desired character.

5.2 Set Data Interval for the Displayed Data

Set a data interval for the displayed data.

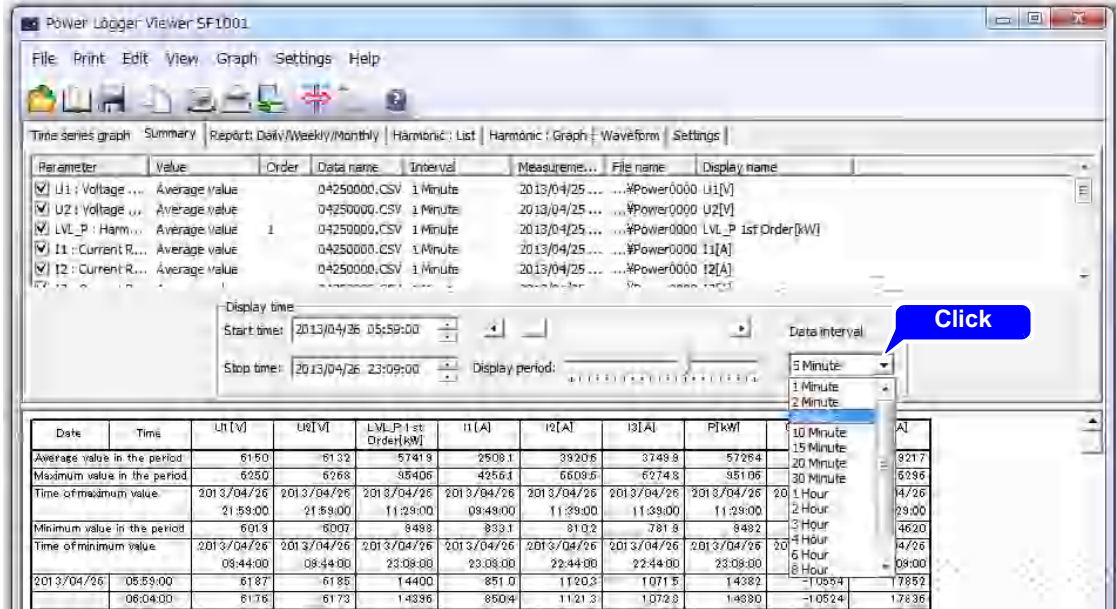

NOTE

- An interval smaller than the interval of the loaded data cannot be set. When multiple pieces of data have been loaded, a larger interval will be used.
- If the start time is changed, the end time will be automatically changed accordingly.

5.3 Set Display Time

Set the start time and stop time of data to be displayed as a summary.

The screenshot shows the 'Power Logger Viewer 5F1001' application window. The 'Display time' section is highlighted with a red box, showing 'Start time: 2013/04/25 17:24:00' and 'Stop time: 2013/04/26 00:24:00'. Below this, a table displays various power parameters over time. The 'Time' column is highlighted with a red box, showing '17:24:00' and '00:24:00' with red arrows pointing to 'Start time' and 'End time' respectively.

Date	Time	U1[V]	U2[V]	LVL_P 1st Order[kW]	I1[A]	I2[A]	I3[A]	P[kW]	Q[kvar]	S[kVA]
Average value in the period		6185	6179	3841.1	1705.5	2685.7	2608.4	38308	-11527	40451
Maximum value in the period		6245	6248	75125	2776.3	5311.2	5134.0	74811	-10486	76139
Time of maximum value		2013/04/25 22:24:00	2013/04/25 22:24:00	2013/04/25 18:24:00	2013/04/25 18:24:00	2013/04/25 18:24:00	2013/04/25 18:24:00	2013/04/25 18:24:00	2013/04/25 00:24:00	2013/04/25 18:24:00
Minimum value in the period		6127	6093	1551.6	891.3	1116.8	1058.3	15484	-1951.5	18737
Time of minimum value		2013/04/25 13:24:00	2013/04/25 13:24:00	2013/04/25 00:24:00	2013/04/25 00:24:00	2013/04/25 00:24:00	2013/04/25 00:24:00	2013/04/25 00:24:00	2013/04/25 13:24:00	2013/04/25 00:24:00
2013/04/25	17:24:00	6150	6114	75125	2776.3	5311.2	5134.0	74811	-12185	76139
	18:24:00	6127	6093	5381.1	1873.0	3994.2	3808.7	53665	-1951.5	55259
	20:24:00	6179	6156	3845.1	1428.8	2351.7	2853.6	39318	-11896	41137
	21:24:00	6208	6204	3831.4	1954.4	2495.2	2486.9	38204	-19003	40165
	22:24:00	6245	6248	2681.6	1801.3	1763.7	1715.5	28754	-11271	30368
	23:24:00	6193	6201	17841	1115.0	1931.4	1181.9	17807	-10580	20763
2013/04/26	00:24:00	6185	6185	1551.6	891.3	1116.8	1058.3	15494	-10486	18737

NOTE

- If the display start time is set to a time other than (measurement start time + an integral multiple of the measurement interval), the displayed time will differ from the actual time. Thus, measurements made immediately before the displayed time of each interval will be displayed as made at the actual time.
- Since the number of display items is fixed, changing either the start time or the end time causes the other parameter to be shifted by the same amount.

5.4 Move Display Range

The display range may be changed by moving the scroll bar.

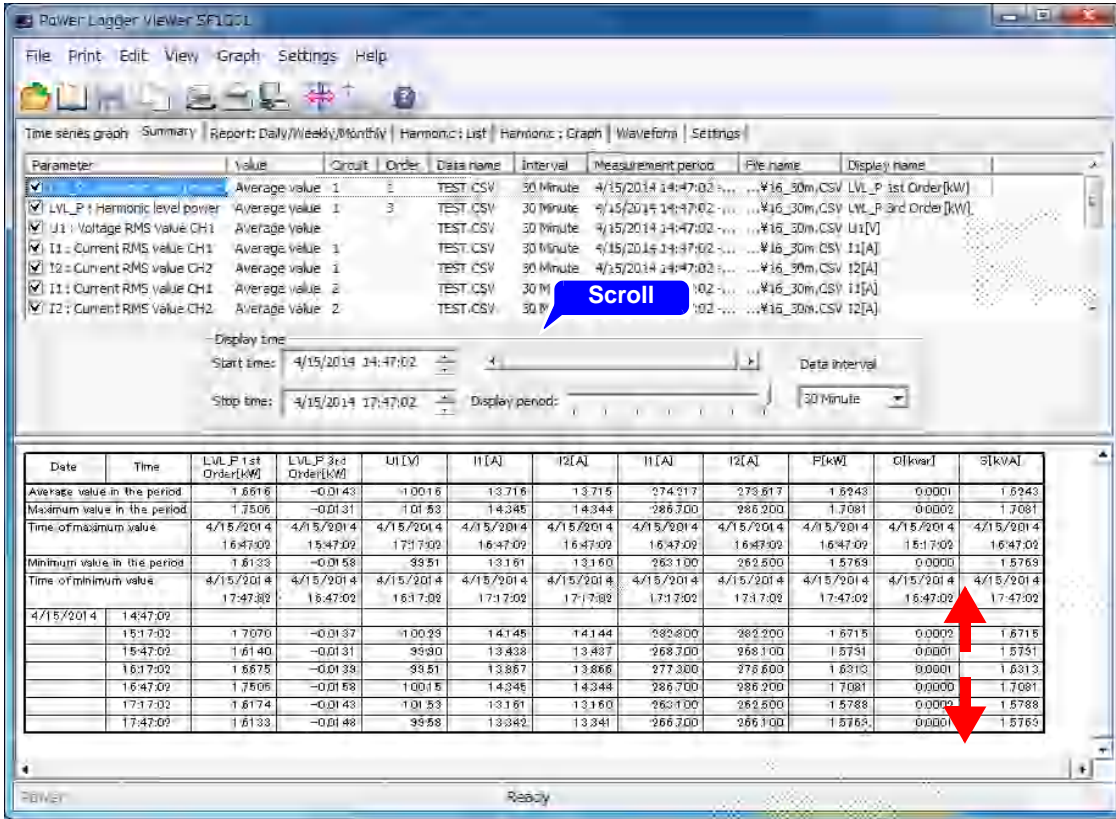

5.5 Set Display Period

The display period may be changed by moving the slider.

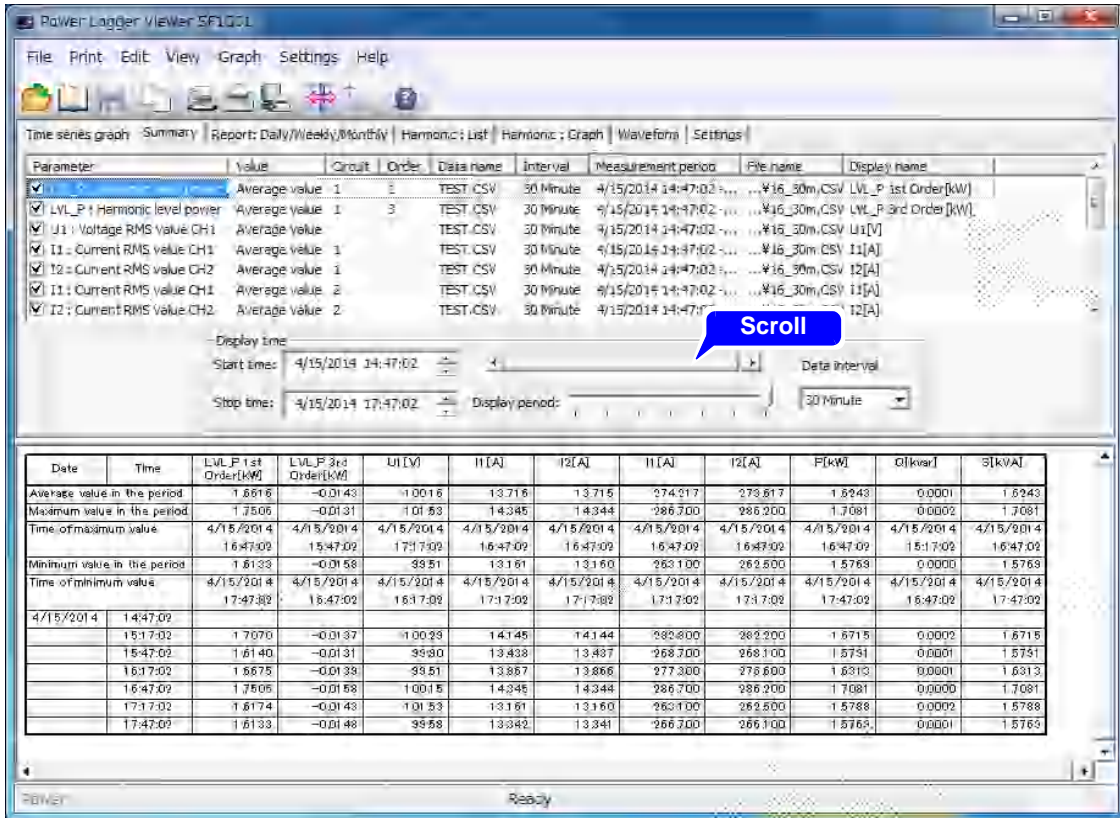

NOTE The data interval, display times, and display period are linked to the Time series graph screen settings.

5.6 Scroll Screen

The screen can be scrolled up and down and right and left using the vertical and horizontal scroll bars.

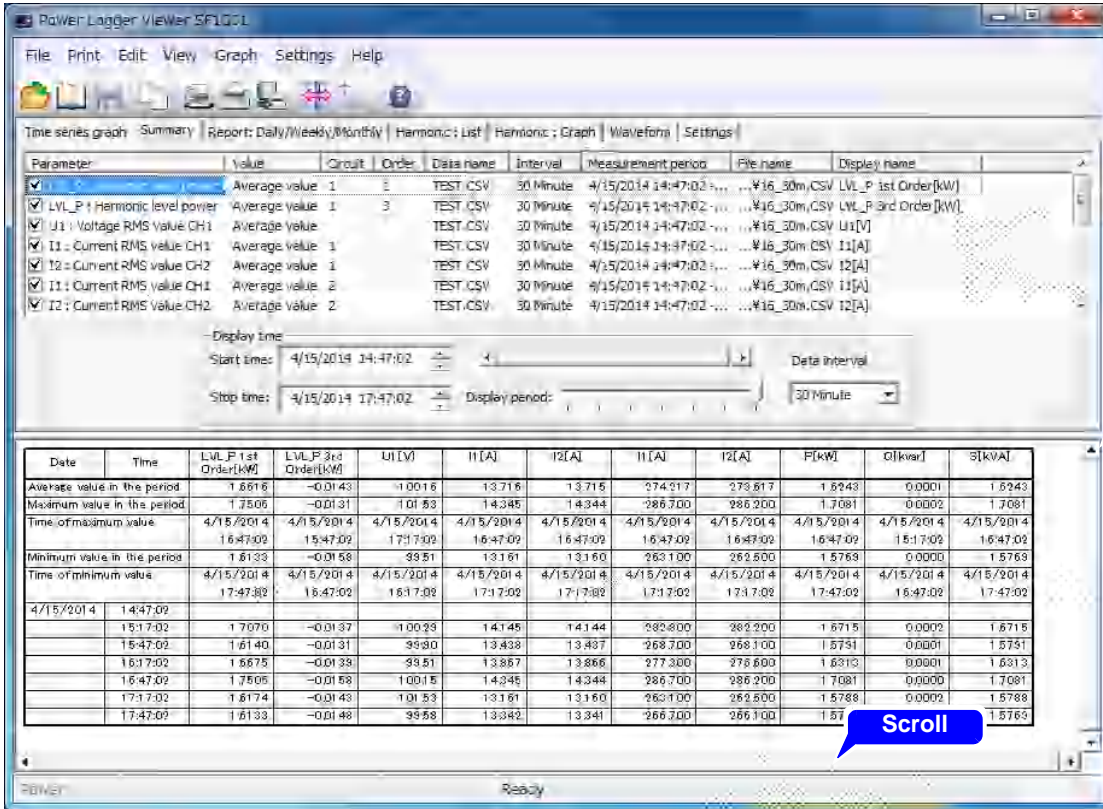

5.7 Change Display Unit

- 1 Select **[Settings]-[Options]** on the menu bar.



- 2 Deselect the **[Display by the number of digits in default setting.]** checkbox on the “Display unit” tab.

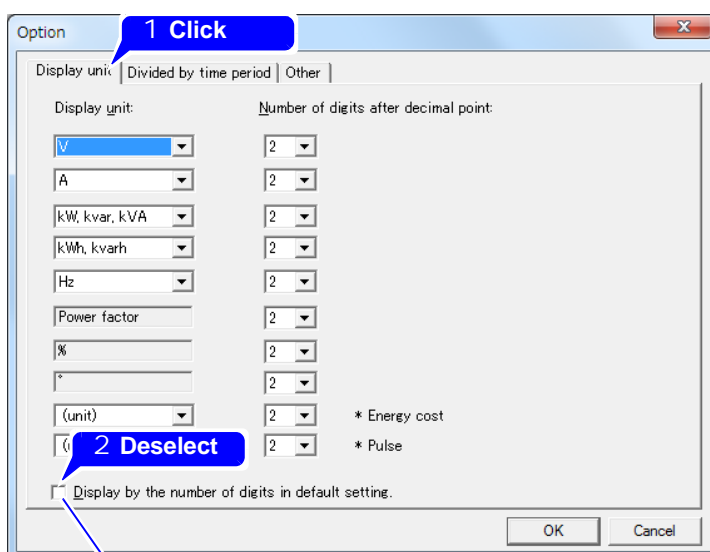

Selecting this checkbox causes data to be displayed using the number of measurement data digits, without regard to the number of decimal places setting.

- 3 Set the display unit for measurement value, and the number of decimals.

5.8 Change Column width

- 1 Click the  button on the tool bar.

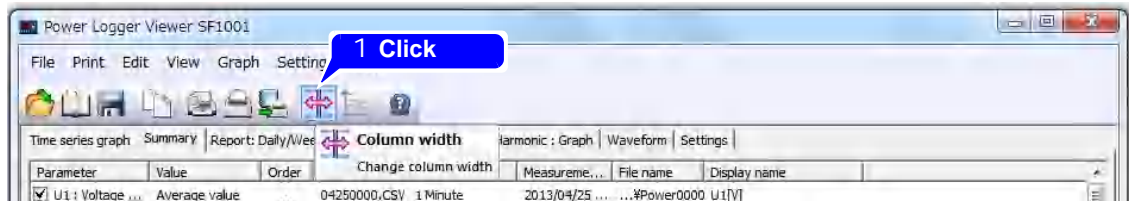

The "Column width" dialog will appear.

- 2 Enter the table column width and click [OK].

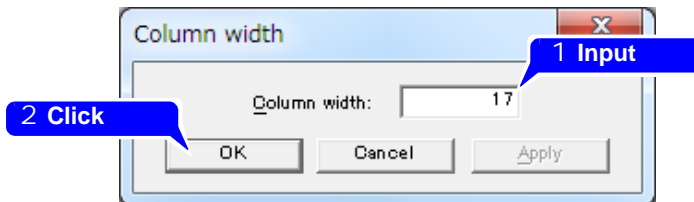

Displaying the Report: Daily/ Weekly/ Monthly

Chapter 6

Display the daily, weekly, or monthly report of selected data.

Click the [\[Report:Daily/Weekly/Monthly\]](#) to display.

The daily report shows numerically the sum of measurements taken at intervals of 30 minutes or 1 hour for a day.

The weekly report shows numerically the sum of measurements taken at intervals of one day for a week.

The monthly report shows numerically the sum of measurements taken at intervals of one day for a month.

Average values are shown for all values except energy, demand quantity, demand value, pulse input value, and electricity charges.

The screenshot shows the 'Power Logger Viewer 5F1001' application window. The 'Reports' menu is open, showing options for 'Daily report', 'Weekly report', and 'Monthly report'. The 'Daily report' is selected. The 'Display time' section shows 'Start time: 2013/04/27' and 'Stop time: 2013/04/27'. The 'Demand period' is set to '30 Minute'. The 'Parameter' list includes 'Pdem+ Demand active power (consumption)', 'U1 Voltage RMS value CH1', 'U2 Voltage RMS value CH2', and 'I2 Current RMS value CH2'. The 'Display name' column shows 'Pdem+ [kW]', 'U1[V]', 'U2[V]', and 'I2[A]'. The 'Value' column shows 'Average value'. The 'Table' section shows a table with columns for 'Division', 'Date', 'Time', 'Pdem+ [kW]', 'U1[V]', 'U2[V]', 'I1[A]', 'I2[A]', 'I3[A]', 'P[kW]', 'Q[kvar]', and 'S[kVA]'. The 'Summary' section shows 'Total', 'Average', 'Maximum demand', 'Time of maximum demand', 'Load factor', 'Demand factor', 'Facility capacity', 'Time division 1 (00:00:00 - 00:00:00)', and 'Time division 2 (00:00:00 - 00:00:00)'. The 'Policy' section shows 'Policy' and 'Rel'.

Callouts in the image point to the following elements:

- Click**: Points to the 'Report: Daily/Weekly/Monthly' menu item.
- Detail item selection (p.60)**: Points to the 'Parameter' list.
- Start time setting (p.63)**: Points to the 'Start time' field.
- Display-range scrolling (p.64)**: Points to the 'Display name' column.
- Demand period selection (p.62)**: Points to the 'Demand period' dropdown.
- Screen scrolling (p.66)**: Points to the table area.
- Report selection (p.65)**: Points to the 'Daily report', 'Weekly report', and 'Monthly report' buttons.

When the **[Pdem+ demand active power]** parameter is selected, the active power demand value (consumption) total, average, maximum demand, maximum demand time, load rate, demand rate, and Facility capacity will be displayed.

NOTE To calculate the demand factor, you must set the equipment capacity. Selecting **[File]-[Load]** on the menu bar will display the "Load data file" dialog box, allowing you to set the equipment capacity for each load.

6.1 Select Data Items to Display

Select items to display and select their checkboxes.

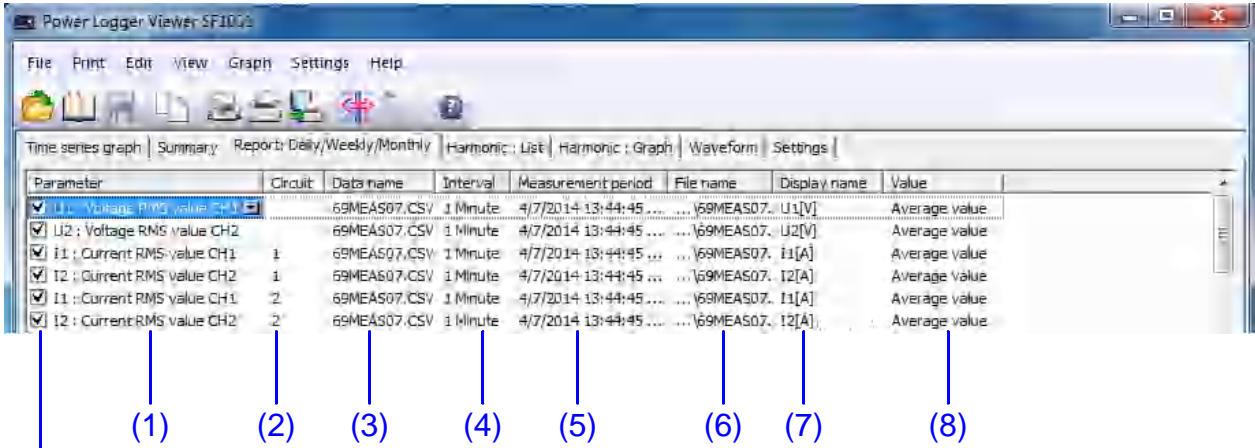

Check boxes

(1) Parameters

Check the box of each item to be displayed.

Click (1) on the parameter of an item, and a list of selectable parameters will appear. Select an item to display from the list.

(2) Circuit

Click (2), and the selectable circuit numbers will be displayed. Select a circuit number to be displayed.

(3) Data name

Click (3) on the data name, and a list of selectable data names will appear. Select the name of the data to be displayed.

(4) Interval

Display the measurement interval of the data.

(5) Measurement period

Display the measurement period of the data.

(6) File name

Display the file name of the data.

(7) Display name

Set the name of each display item to be used in printout.

Click (7) on the display name, and the "Display name" dialog will appear.

The display names are also used as form item names.

Overview of marking	
%D	Data name
%V	Average value, maximum value, minimum value
%I, %i	Parameter(U1 etc)
%U, %u	Unit
%O, %o	Order
%C, %c	Circuit

Check to set the display name of each item separately.

Select and enter a symbol from the symbol list.
You may also enter any desired character.

(8) Value

Display the data type.

Voltage waveform peak values and current waveform peak values display the maximum value and energy, demand quantity, demand value, pulse input value, and electricity charges display a blank and others display the average value.

6.2 Select Demand Period

Select a demand period for the data to be displayed at either 30 minutes or 1 hour.

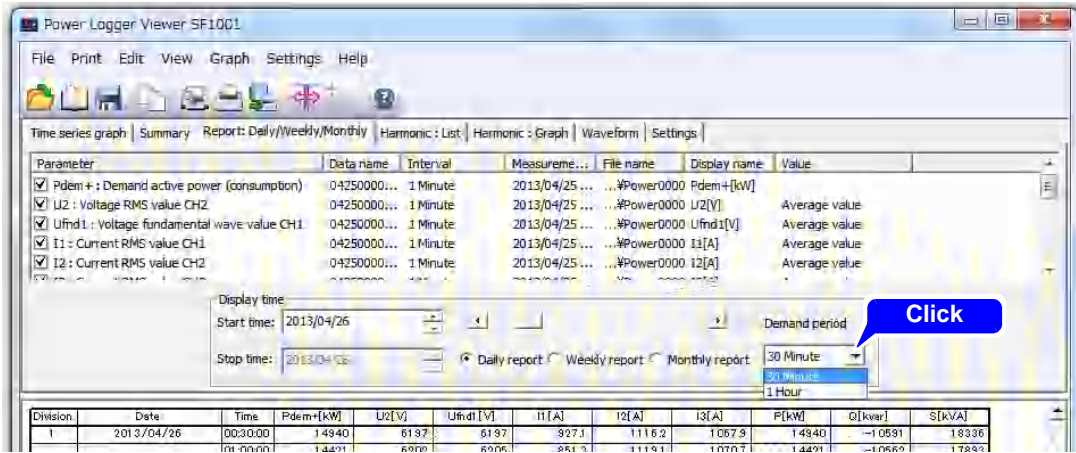

NOTE An interval smaller than the measurement interval of the loaded data cannot be set.

6.4 Move Display Range

The display range may be changed by moving the scroll bar.

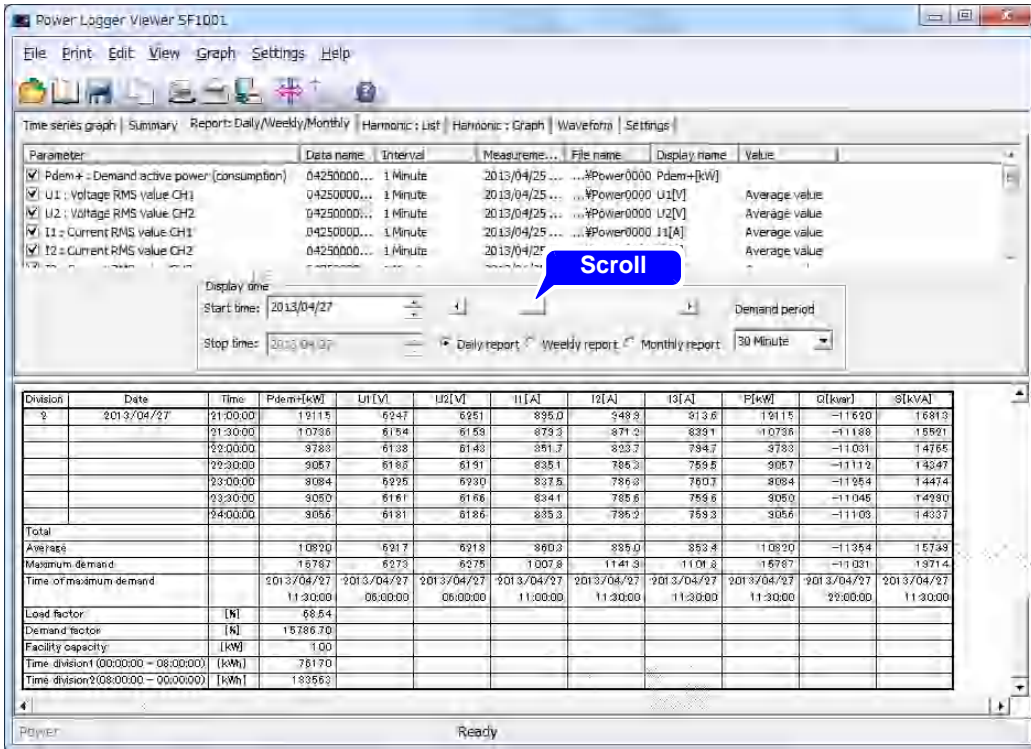

6.7 Change Display Unit

- 1 Select **[Settings]-[Options]** on the menu bar.



- 2 Deselect the **[Display by the number of digits in default setting.]** checkbox on the “Display unit” tab.

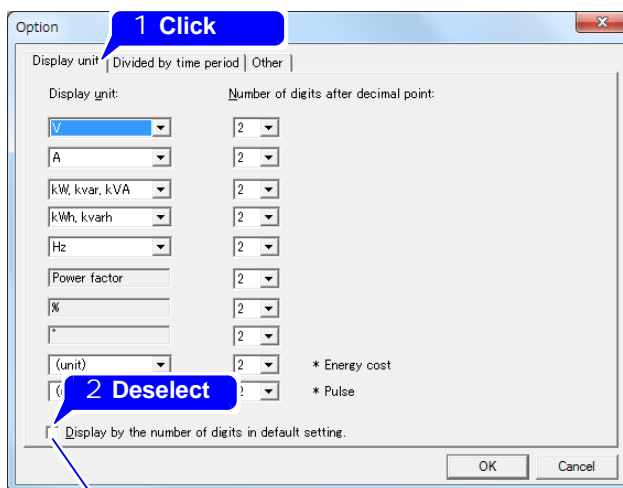

Selecting this checkbox causes data to be displayed using the number of measurement data digits, without regard to the number of decimal places setting.

- 3 Set the display unit for measurement value, and the number of decimals

6.8 Changing the Report Column Width

- 1 Click the  button on the tool bar.

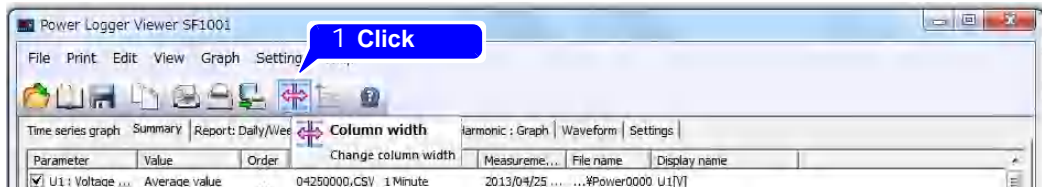

The "Column width" dialog will appear.

- 2 Enter the table column width and click [OK].

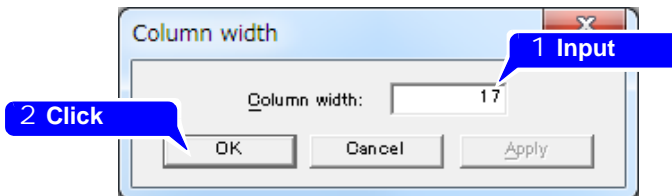

6.9 Displaying the Load Factor and Demand Factor

The load factor and demand factor can be calculated and displayed in the last row of the form for the **[Pdem+ Demand active power (consumption)]** parameter. The load factor indicates the extent of fluctuations in power demand over the tabulation interval, while the demand factor indicates the maximum power used as a percentage of the installed load equipment capacity.

If you select **[Pdem+ Demand active power (consumption)]** for multiple parameters, the total **[Pdem+ Demand active power (consumption)]** will be displayed in the last column.

The screenshot shows the Power Logger Viewer SF1001 interface. The main window displays a table of power consumption data for a specific time period. The table includes columns for Division, Date, Time, Pdem+ : Demand active power (consumption) [kW], and Sum of Pdem+ : demand value of active power (consumption) [kW]. The 'Load factor' and 'Demand factor' rows are highlighted with a red box.

Division	Date	Time	Pdem+ : Demand active power (consumption) [kW]	Pdem+ : Demand active power (consumption) [kW]	Sum of Pdem+ : demand value of active power (consumption) [kW]
1	9/13/2014	22:00:00	2.225	2.222	4.447
		23:00:00	2.271	2.270	4.541
		24:00:00	2.874	2.872	5.746
Total					
Average			2.842	2.837	5.679
Maximum demand			4.283	4.272	
Time of maximum demand		9/13/2014		9/13/2014	
Load factor		[%]	66.35	66.41	
Demand factor		[%]	4.28	4.27	
Time division1(00:00:00 - 00:00:00)		[kWh]	68.21	68.09	136.30
Power cost 1(0.1000\$/kWh)	Reference value		6.8206	6.8091	13.6297

- NOTE**
- The calculation formula is given in "12.3 Calculation Formulas" (p.110).
 - In order to calculate demand factor, you must first set the equipment capacity. For more information about how to do so, see "Loading Folders (Model PW3360, Model PW3365)" (p.9) to "Changing the Facility Capacity Setting" (p.16).
 - Only Pdem+ parameters are added to calculate the total demand active power (consumption). Pdem+1, Pdem+2, and Pdem+3 parameters are not included.

6.10 Displaying Active Energy by Time of Day

This section describes how to set operating hours and calculate active energy by time of day. This information is displayed in the last line of the form under the **[Pdem+ Demand active power (consumption)]** item.

7 Select **[Settings]-[Options]** on the menu bar.



2

Set the operating hours and time divisions on the **[Divided by time period]** tab.

Operating hours are set in 30-minute blocks. You cannot set hours that span multiple dates.

Selecting this checkbox displays active energy values by time.

Selecting this checkbox displays electric charges.

Set the currency unit for electric charges.

Up to four time divisions can be set.

Example display

Division	Date	Time	Pdem+ [kW]	U1 [V]	U2 [V]	I1 [A]	I2 [A]	P [kW]
1	4/27/2013	21:00:00	5.171	104.79	104.49	42.19	43.17	
		22:00:00	5.163	103.22	102.92	42.61	43.61	
2	4/27/2013	23:00:00	5.162	104.24	103.94	42.98	43.99	
		24:00:00	5.162	103.66	103.36	43.09	44.10	
Total								
Average			5.185	104.34	104.05	43.22	44.24	
Maximum demand			5.213	105.19	104.89	44.02	45.08	
Time of maximum demand			4/27/2013 12:00:00	4/27/2013 06:00:00	4/27/2013 06:00:00	4/27/2013 12:00:00	4/27/2013 12:00:00	4/27/2013 12
Load factor			[%]	99.48				
Demand factor			[%]	5.21				
Facility capacity			[kW]	100.000				
Time division1(00:00:00 - 22:00:00)			[kWh]	114.08				
Time division2(22:00:00 - 00:00:00)			[kWh]	10.37				
Power cost1(0.1000\$/kWh)			Reference value	11.4079				
Power cost2(0.1000\$/kWh)			Reference value	1.0368				

NOTE

- Electric charges are displayed for reference purposes only. (Displayed values cannot be used for billing or to establish power use.)
- Electric charges are calculated by multiplying the active power by the electric charge rate. This value differs from the "electric charges" parameter output by the PW3360 and PW3365.
- The operating system's currency symbol setting is used as the default value for the electric charge currency unit.
- The default electric charge rate is \$0.1/kWh. Change the setting as necessary.

3

Click **[OK]**.

To discard changes, click **[Cancel]**.

6.11 Displaying Active Energy Converted into CO2 Amount

The active energy can be converted into CO2 Amount and displayed.

1 Select **[Settings]-[Options]** on the menu bar.

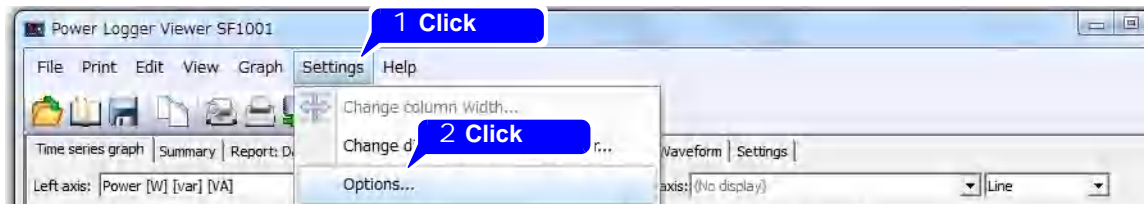

2 Select the Display CO2 conversion values on the **[Divided by time period]** tab.

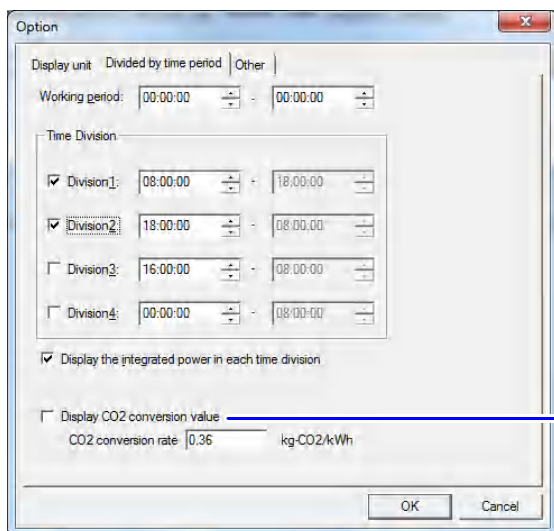

Selecting this checkbox displays CO2 conversion value.

3 Click **[OK]**.

To discard changes, click **[Cancel]**.

NOTE

- The CO2 converted value is equivalent to the integrated active power [kWh] value multiplied by the CO2 conversion rate.
- The initial setting of the CO2 conversion rate is "0.36 kg-CO2/kWh" so that change the rate by yourself accordingly.

Displaying a Harmonic List Chapter 7

This chapter describes how to display harmonic data for a user-specified time as a list of values. The level, content percentage, and phase angle will be shown at the same time. If the loaded data does not include harmonic data, this information cannot be displayed.

Click the [Harmonic:List] tab to display the screen.

Selection of display channel (p.74)

Display time setting (p.76)

Order	Active power (sum)			Voltage			Current		
	LVL_PCircuit1 [kW]	[N]	[-]	LVL_U1 [V]	[N]	[-]	LVL_I1 (Circuit) [A]	[N]	[-]
1	18.801	100.00	0.00	100.38	100.00	0.00	84.42	100.00	-3.41
2	0.000	0.00	0.00	0.01	0.01	-144.57	0.28	0.31	-131.08
3	-0.108	-0.57	111.11	2.88	2.88	44.53	88.87	85.18	146.58
4	-0.000	-0.00	110.90	0.02	0.02	-39.30	0.28	0.31	3.65
5	-0.004	-0.02	3.82	2.88	2.84	-147.28	78.42	83.05	-56.80
6	-0.000	-0.00	180.00	0.02	0.02	-42.17	0.56	0.57	138.47
7	-0.036	-0.18	111.47	1.36	1.34	-21.0	62.33	65.57	100.11
8	0.000	0.00	0.00	0.04	0.04	-22.16	0.23	0.24	-77.85
9	-0.052	-0.27	180.00	0.62	0.61	37.60	44.56	47.20	-102.43
10	0.000	0.00	0.00	0.04	0.04	37.36	0.22	0.23	-67.88
11	-0.027	-0.14	180.00	0.58	0.55	-154.10	27.85	28.49	56.76
12	-0.000	-0.00	122.76	0.06	0.06	89.03	0.21	0.22	-163.84
13	-0.011	-0.06	180.00	0.48	0.48	4.52	14.26	15.08	-133.01
14	-0.000	-0.00	180.00	0.07	0.07	106.56	0.06	0.06	-61.37
15	0.007	0.04	0.00	0.58	0.57	53.54	5.79	6.13	58.18
16	0.000	0.00	40.78	0.07	0.07	130.18	0.07	0.08	-167.05
17	-0.002	-0.01	147.88	0.30	0.30	155.12	5.60	5.93	-85.69

NOTE

When the display time is the time of the beginning of the data, a blank is displayed because there is no value.

7.1 Select Data Channel to Display

Select a data channel.

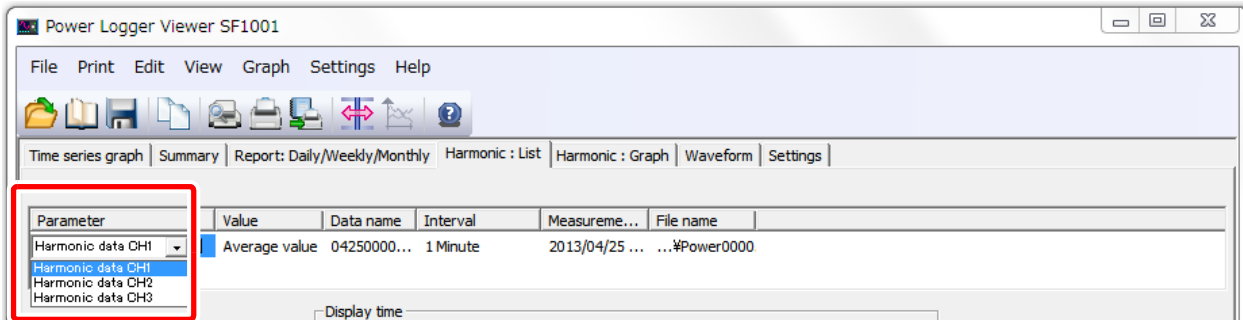

7.2 Select Detail Items

Select items to display.

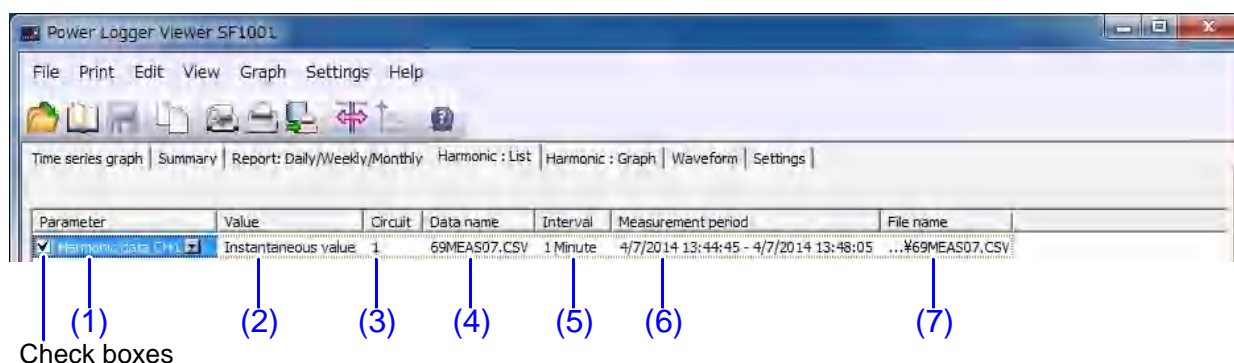

Check boxes

(1) Parameter

Check the box of each CH to be displayed.
Select a CH to display from the list.

(2) Value

Click (2) on the value of an item, and a list of selectable data types (instantaneous, average, maximum, and minimum) will appear. Select a data type from the list.
If the loaded data contains only average values, you will only be able to select average values as the data type.

(3) Circuit

Click (3), and the selectable circuit numbers will be displayed. Select a circuit number to be displayed.

(4) Data name

Click (4) on the data name, and a list of selectable data names will appear. Select the name of the data to be displayed.

(5) Interval

Display the measurement interval of the data to be loaded.

(6) Measurement period

Display the measurement period of the data to be loaded.

(7) File name

Display the file name of the data to be loaded.

7.3 Setting the Display Time

Set the display time using the display time text box or scroll bar.

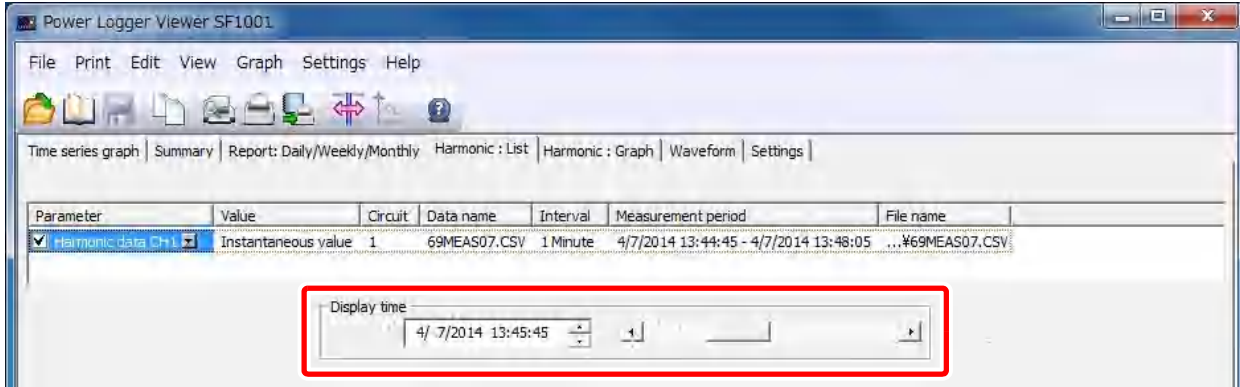

7.4 Change Display Unit

- 1 Select **[Settings]-[Options]** on the menu bar.

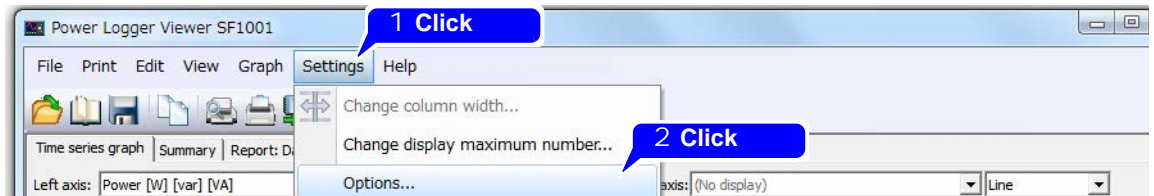

- 2 Deselect the **[Display the number of digits in default setting.]** checkbox on the “Display unit” tab.

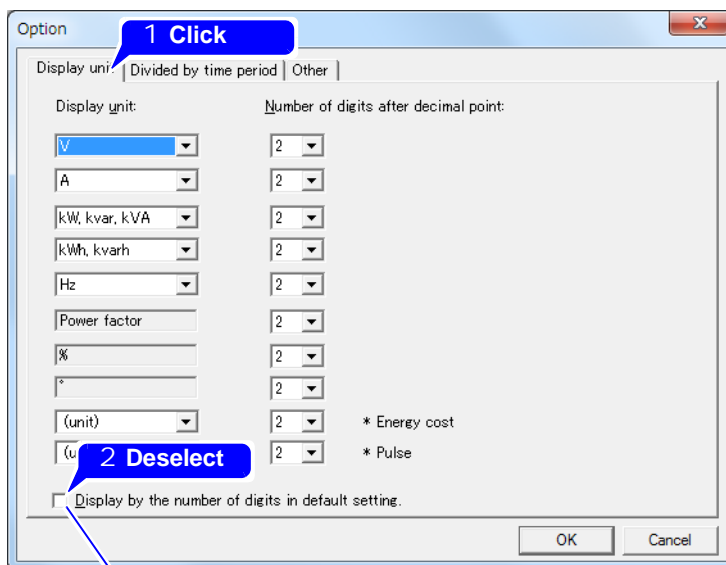

Selecting this checkbox causes data to be displayed using the number of measurement data digits, without regard to the number of decimal places setting.

- 3 Set the display unit for measurement value, and the number of decimals

- 4 Click the **[OK]**.

Displaying a Harmonic Graph

Chapter 8

This chapter describes how to display harmonic data for a user-specified time as a graph. A vector graph will be shown for [\[Harmonic phase angle power\]](#) data only. If the loaded data does not include harmonic data, this information cannot be displayed. Click the [\[Harmonic:Graph\]](#) tab to display the screen.

Selection of data parameter (p.80)

Detail item selection (p.80)

Display start time setting (p.82)

Cursor measured value (p.82)

Cursor (p.82)

Setting the Axis to a Linear Axis or LOG Axis (p.82)

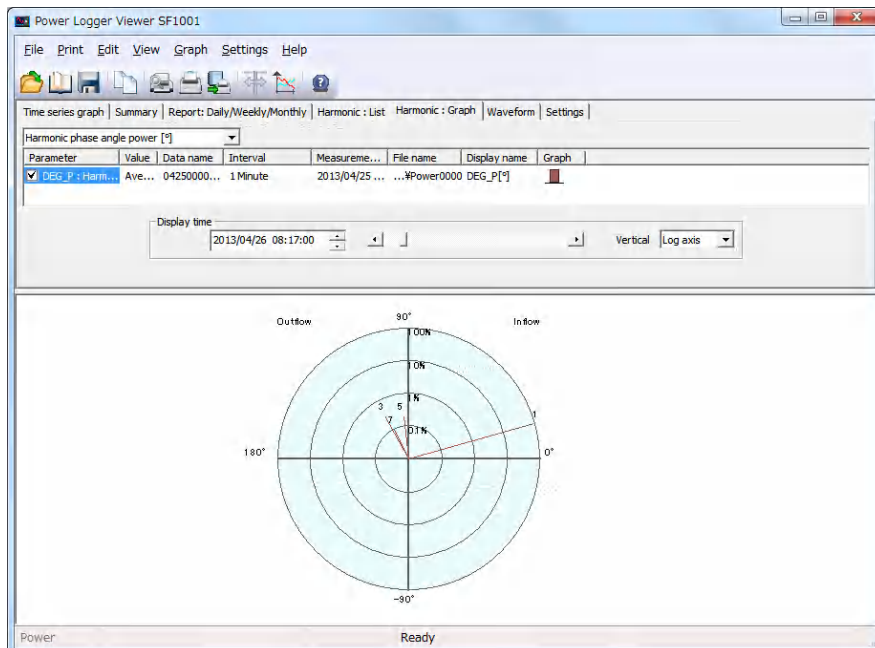
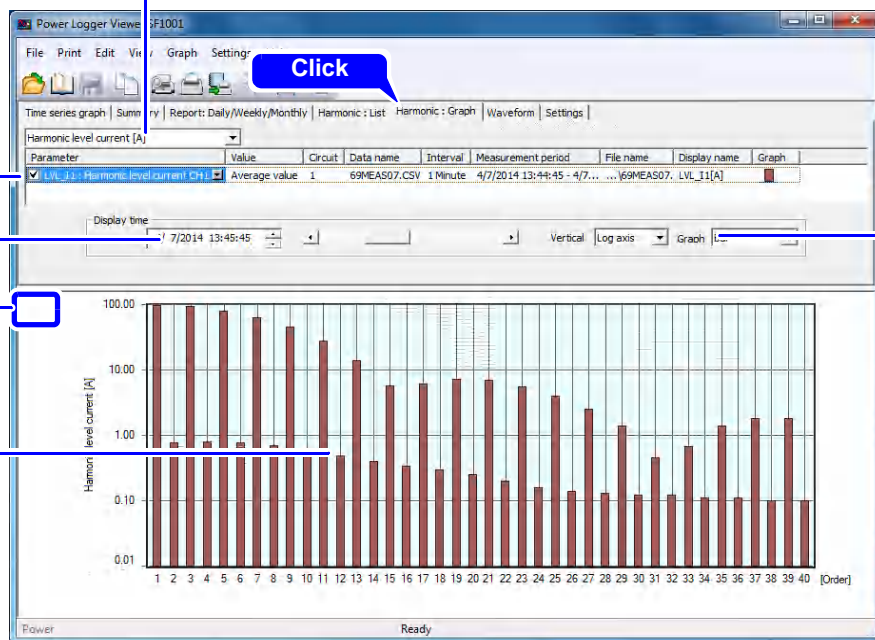

8.1 Select Data Items to Display

Select a data item.

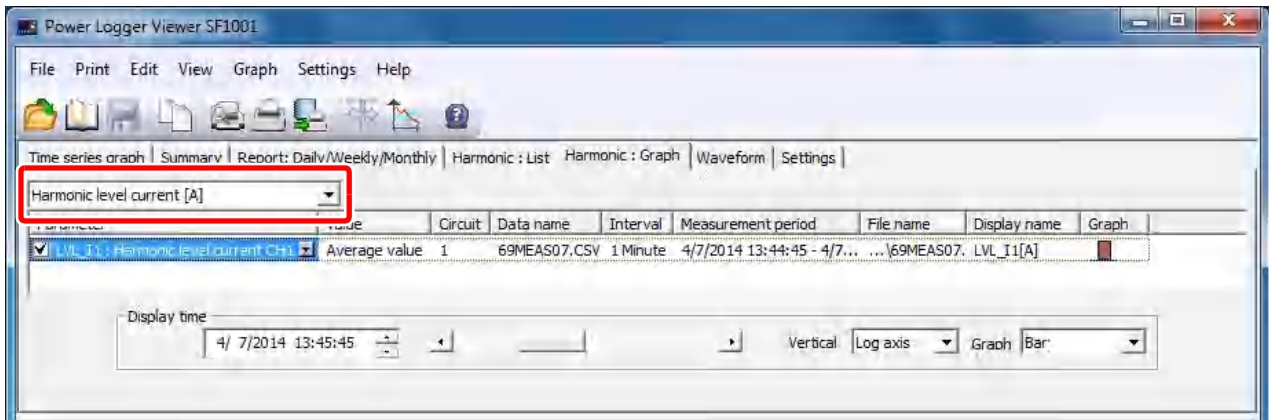

8.2 Select Detail Items

Select items to display.

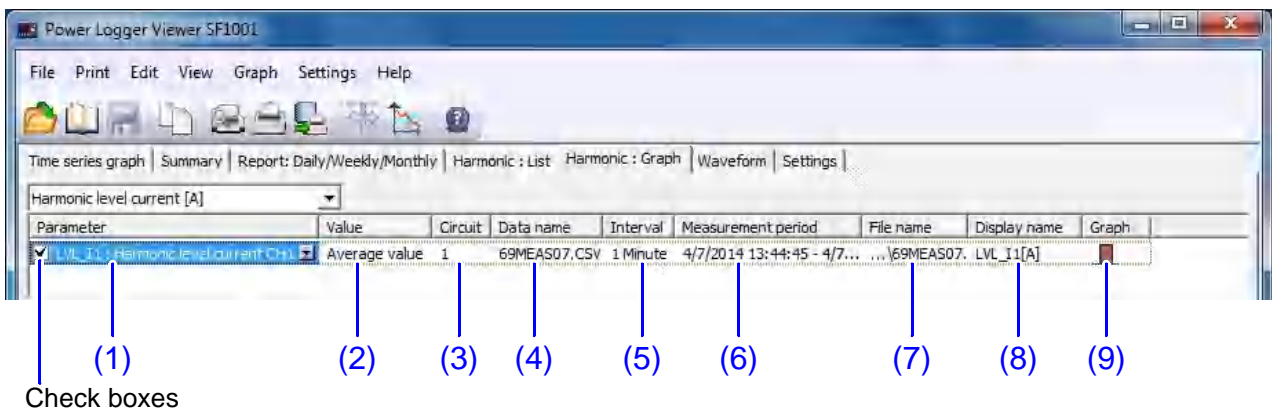

(1) Parameter

Check the box of each item to be displayed.

Click (1) on the parameter of an item, and a list of selectable parameters will appear. Select an item to display from the list.

(2) Value

Click (2) on the value of an item, and a list of selectable data types (instantaneous, average, maximum, and minimum) will appear. Select a data type from the list.

(3) Circuit

Click (3), and the selectable circuit numbers will be displayed. Select a circuit number to be displayed.

(4) Data name

Click (4) on the data name, and a list of selectable data names will appear. Select the name of the data to be displayed.

(5) Interval

Display the measurement interval of the data to be loaded.

(6) Measurement period

Display the measurement period of the data to be loaded.

(7) File name

Display the file name of the data to be loaded.

(8) Display name

Set the name of each display item to be used in printout.

Click (8) on the display name, and the "Display name" dialog will appear.

The display name setting applies to time-series graph screen copies and when printing.

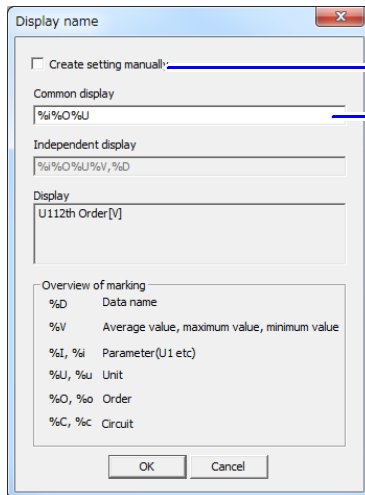

Check to set the display name of each item separately.

Select and enter a symbol from the symbol list.
You may also enter any desired character.

(9) Graph

Click (9) on the graph, and the "Change graph format" dialog will appear.

This box allows the line color to be set.

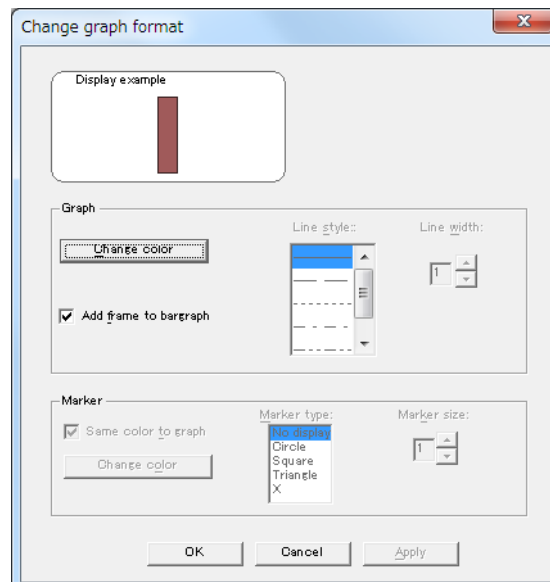

8.3 Setting the Display Time

Set the display time using the display time text box or scroll bar.

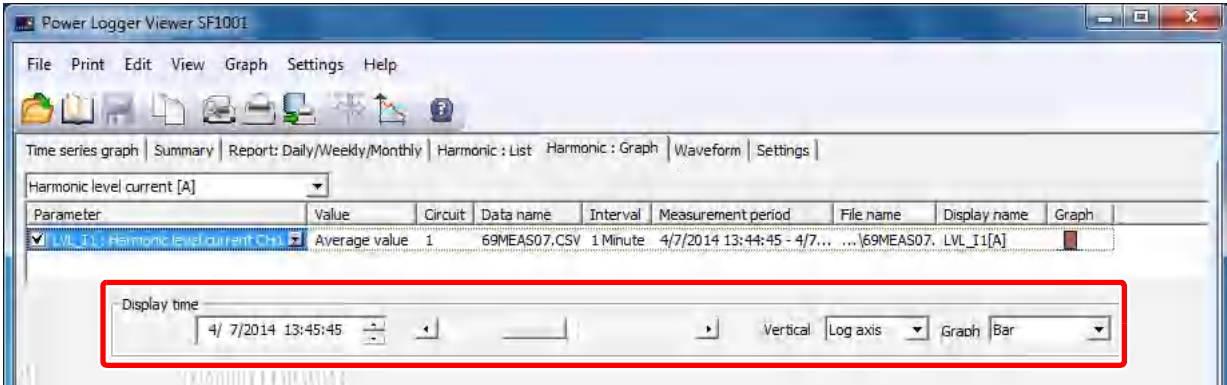

8.4 Setting the Axis to a Linear Axis or LOG Axis

Set the horizontal axis to use either a linear axis or LOG axis when displaying harmonic levels or content percentage.

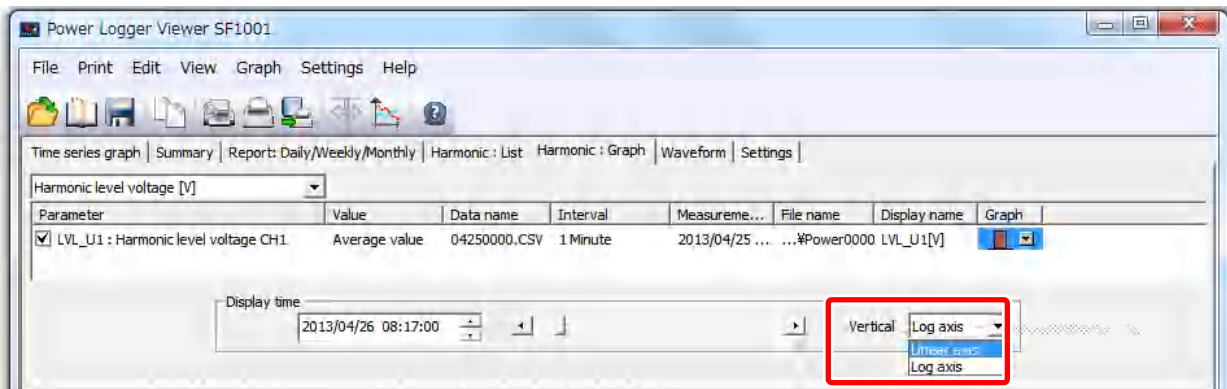

8.5 Displaying the Value at the Cursor Position

Click in the graph display area, and the cursor will appear. The measurement of the point at which the cursor is located will be displayed. The cursor can also be moved using the ← and → keys on the keyboard. To hide the cursor, click anywhere outside the graph display area.

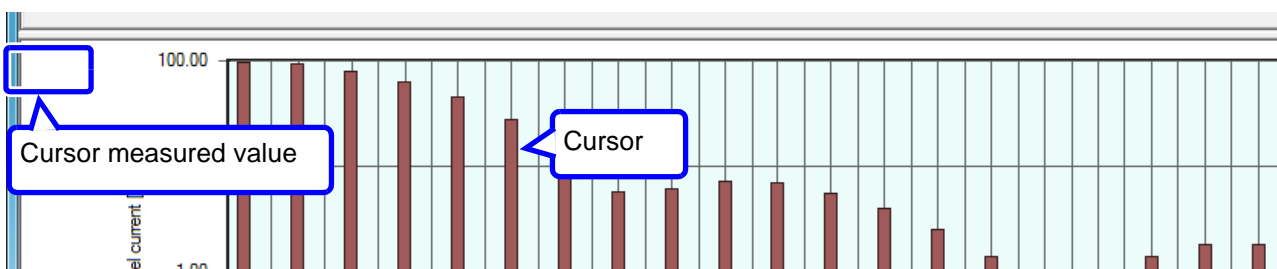

8.6 Set Vertical Axis

- 1 Click the  on the tool bar.

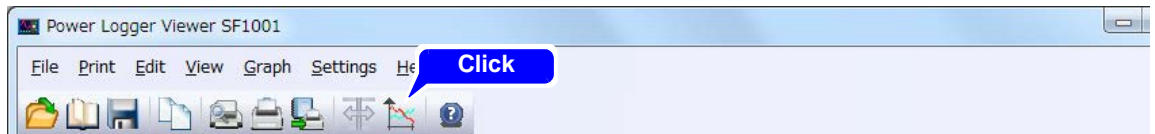

The "Vertical axis settings" dialog will appear.

- 2 Set the vertical axis.

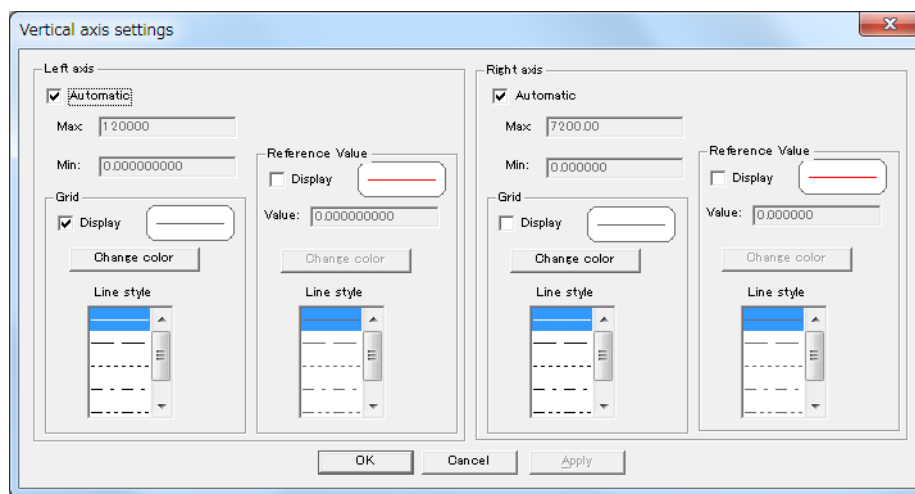

- 3 Click the [OK].

Parameters

Description

Left axis, Right axis	Changes the upper limit value (Max) and lower limit value (Min) for the vertical axis. (These values are usually set automatically.) The values can also be changed using the vertical slider.
Grid	Show or hide the grid line. Set the color and line style.
Reference Value	Show or hide the reference value. Set the value, color, and line style.

NOTE The grid color of the time axis is determined by the grid color of the left axis.

8.7 Change Display Unit

- 1 Select **[Settings]-[Options]** on the menu bar.



- 2 Deselect the **[Display by the number of digits in default setting.]** checkbox on the “Display unit” tab.

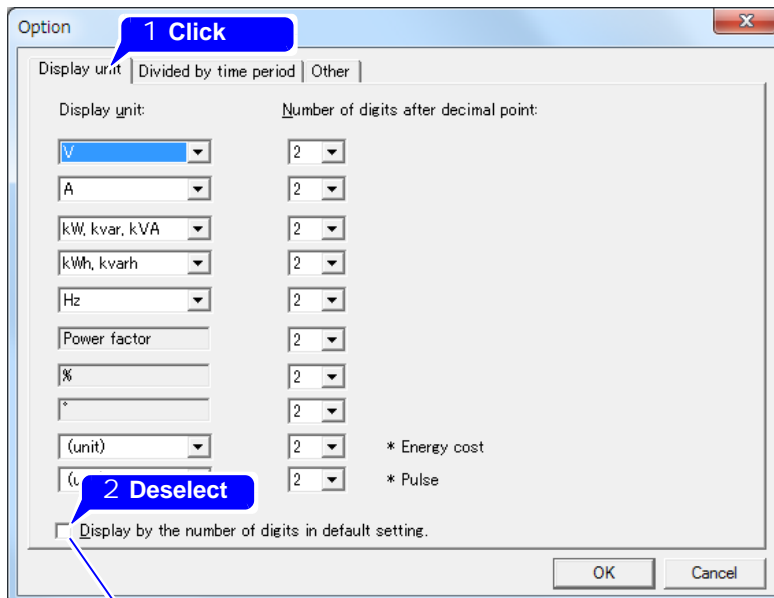

Selecting this checkbox causes data to be displayed using the number of measurement data digits, without regard to the number of decimal places setting.

- 3 Set the display unit for measurement value, and the number of decimals

- 4 Click the **[OK]**.

NOTE When using the LOG axis, the setting for the number of digits after the decimal point is invalid.

8.8 Change Background Color

1 Select **[Settings]-[Options]** on the menu bar.

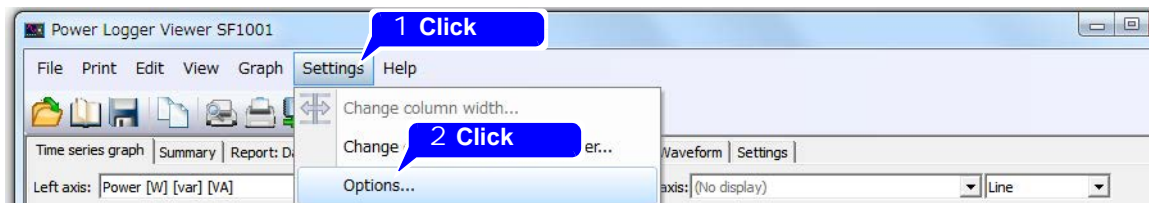

2 Check the “Change the background color” box and click the **[Change color]**.

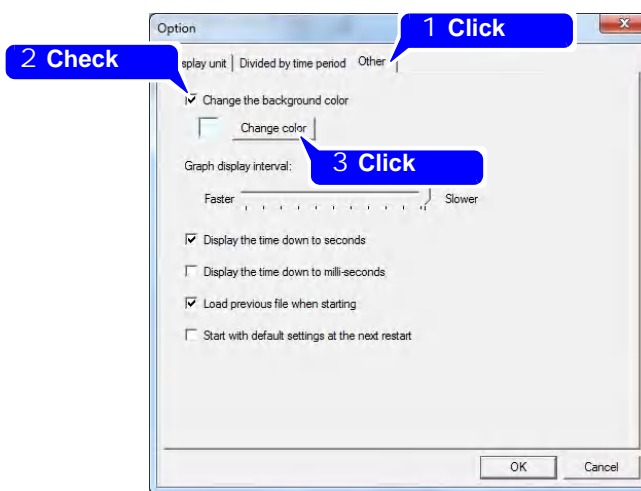

The “Color” dialog will appear.

3 Select a background color.

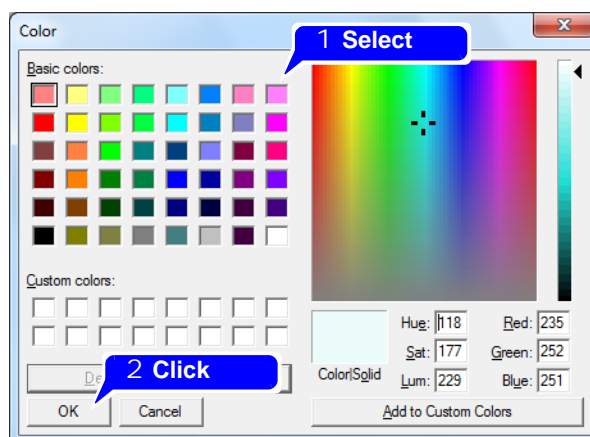

4 Click the **[OK]**.

- NOTE**
- The graph background color applies only to the SF1001 graph display and screen copies.
 - White is used as the graph background color during screen and report printing.

Displaying Measurement Data Waveforms

Chapter 9

This chapter describes how to display the voltage and current waveforms for a user-specified time. If the loaded data does not include waveform data, this information cannot be displayed. Click the [Waveform] tab to display the screen.

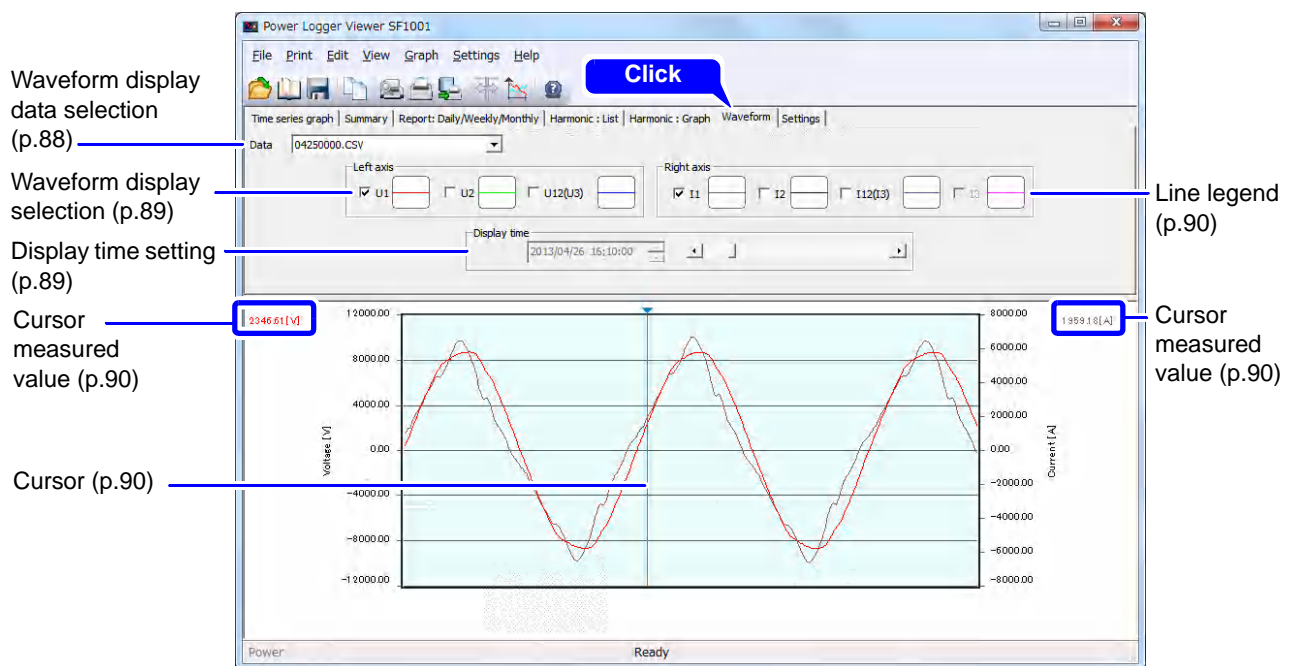

9.1 Selecting the Waveform Display Data

Select the data name for which to display a waveform.

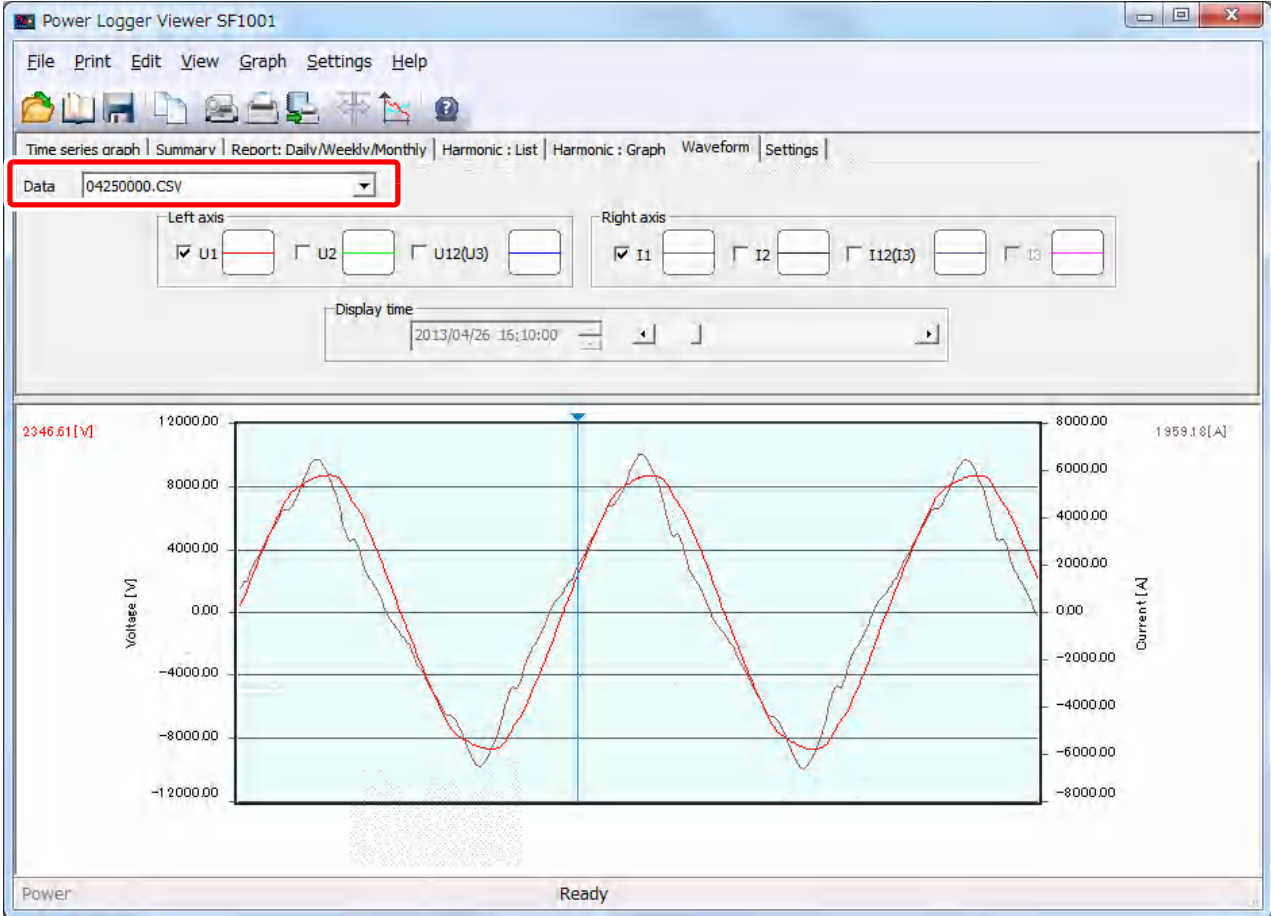

9.2 Toggleing the Waveform Display On and Off

Selecting the checkbox for the parameter you wish to display causes that waveform to be displayed. Checkboxes for waveforms whose parameters were not saved cannot be checked.

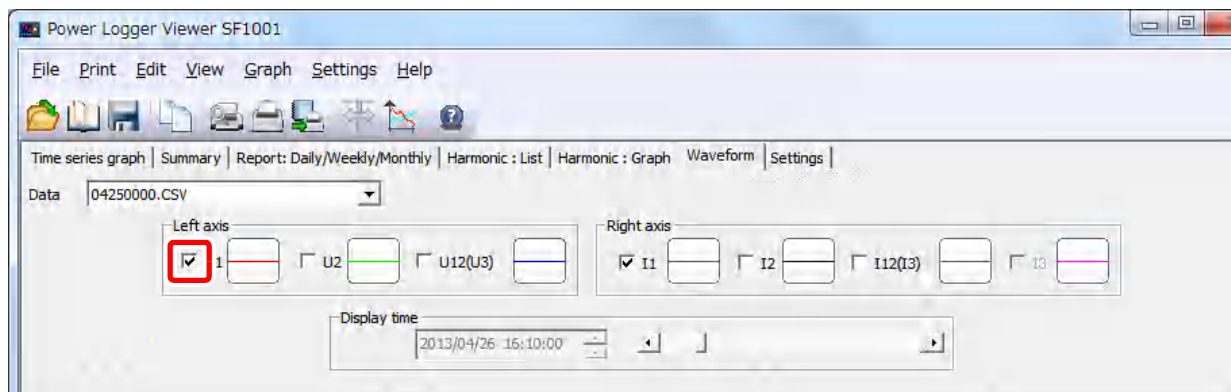

9.3 Setting the Start Time

Set the display time with the display time scroll bar.

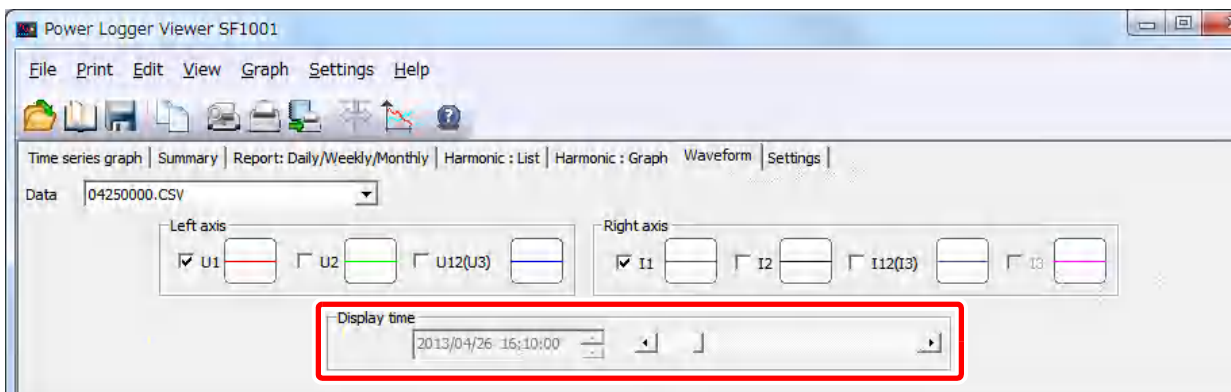

NOTE You cannot set the display time by entering a value directly.

9.4 Displaying the Value at the Cursor Position

Click in the graph display area, and the cursor will appear. The measurement of the point at which the cursor is located will be displayed. The cursor can also be moved using the ← and → keys on the keyboard. To hide the cursor, click anywhere outside the graph display area.

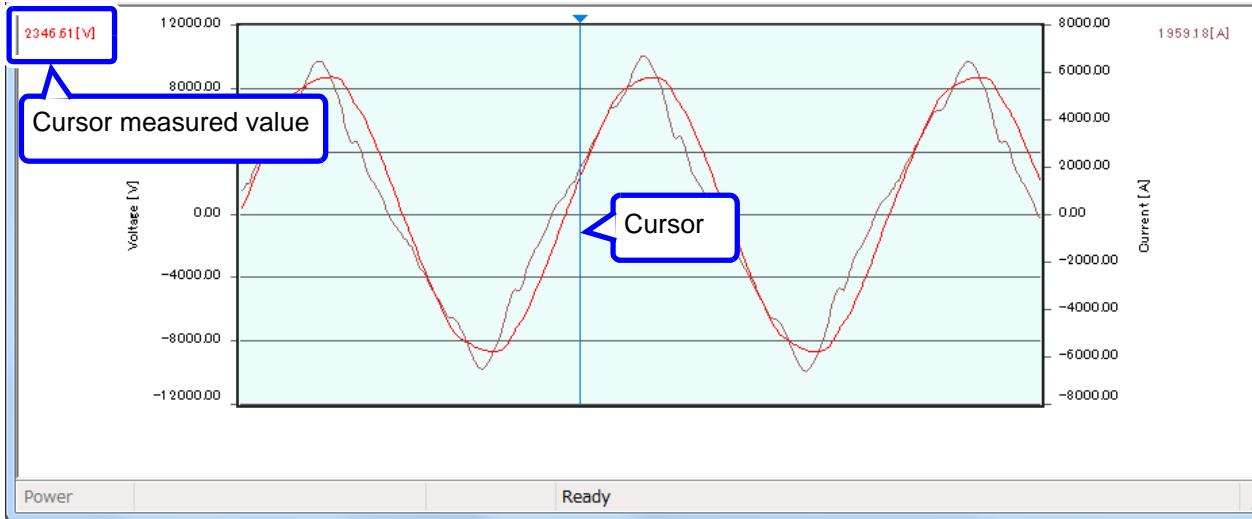

9.5 Changing the Graph Display

Click the legend for each parameter's line and set the color, style, and thickness of the graph line and the color, type, and size of the marker on the "Change graph format" dialog box. The line style can only be changed when the line thickness is set to 1.

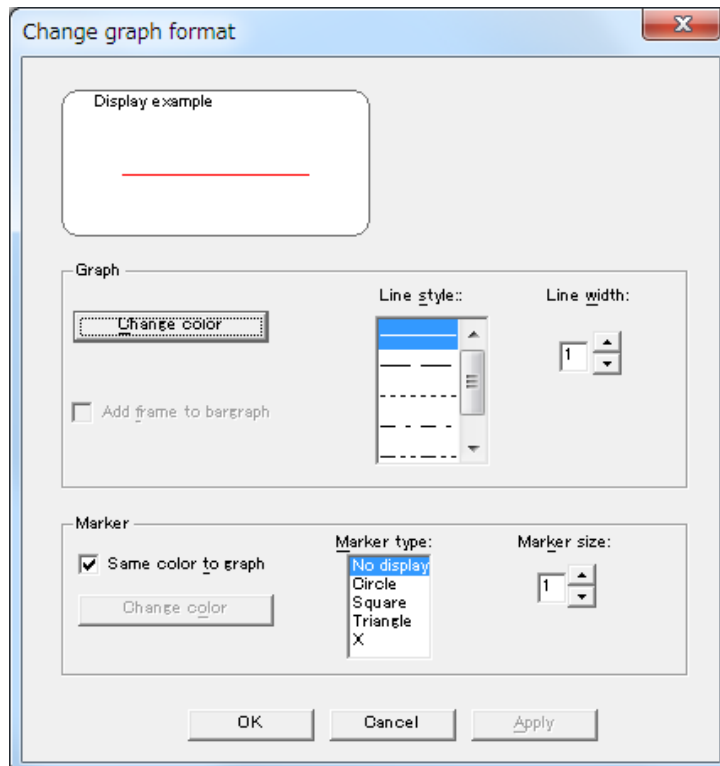

9.6 Set Vertical Axis

- 1 Click the  on the tool bar.

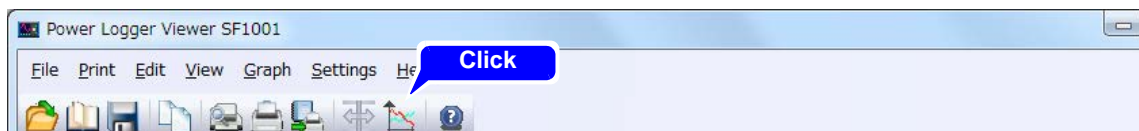

The “Vertical axis settings” dialog will appear.

- 2 Set the vertical axis.

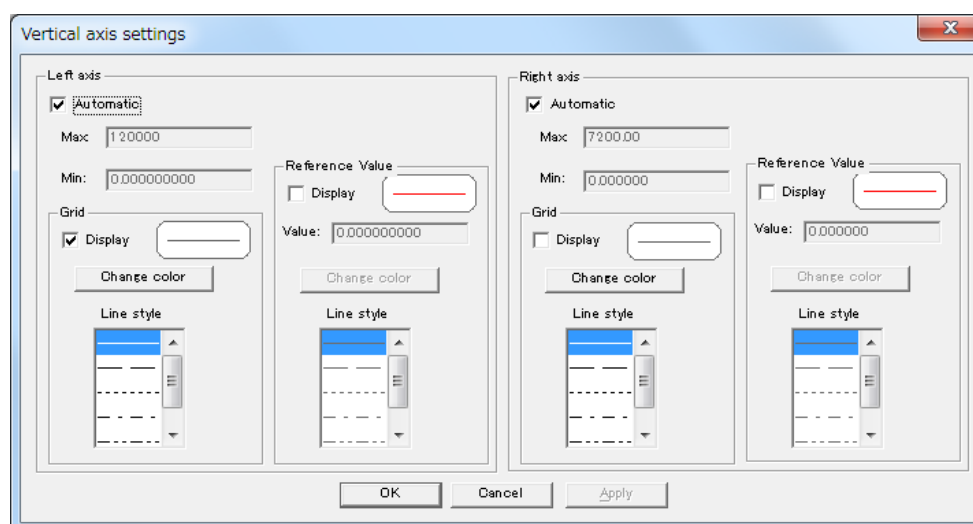

- 3 Click the [OK].

Parameters

Description

Left axis, Right axis

Changes the upper limit value (Max) and lower limit value (Min) for the vertical axis. (These values are usually set automatically.) The values can also be changed using the vertical slider.

Grid

Show or hide the grid line. Set the color and line style.

Reference Value

Show or hide the reference value. Set the value, color, and line style.

NOTE The grid color of the time axis is determined by the grid color of the left axis.

9.7 Change Display Unit

- 1 Select **[Settings]-[Options]** on the menu bar.



- 2 Set the display unit for measurement value, and the number of decimals

- 3 Click the **[OK]**.

9.8 Change Background Color

1 Select **[Settings]-[Options]** on the menu bar.

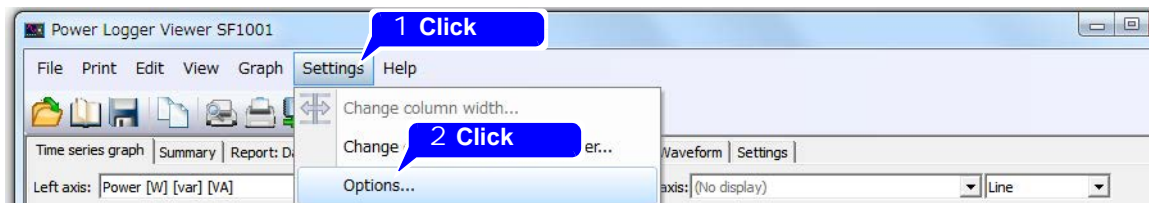

2 Check the “Change the background color” box and click the **[Change color]**.

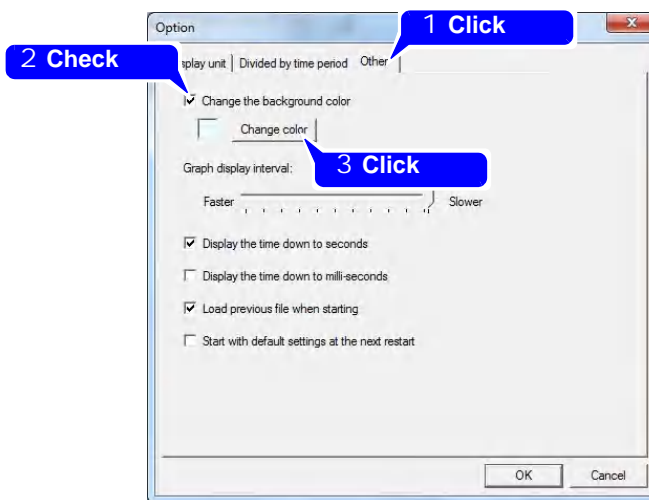

The "Color" dialog will appear.

3 Select a background color.

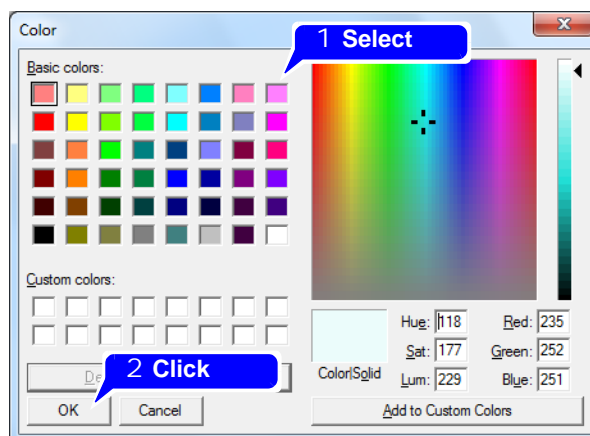

4 Click the **[OK]**.

- NOTE**
- The graph background color applies only to the SF1001 graph display and screen copies.
 - White is used as the graph background color during screen and report printing.

Displaying Settings for Measurement Data

Chapter 10

Click the “Settings” tab to display.

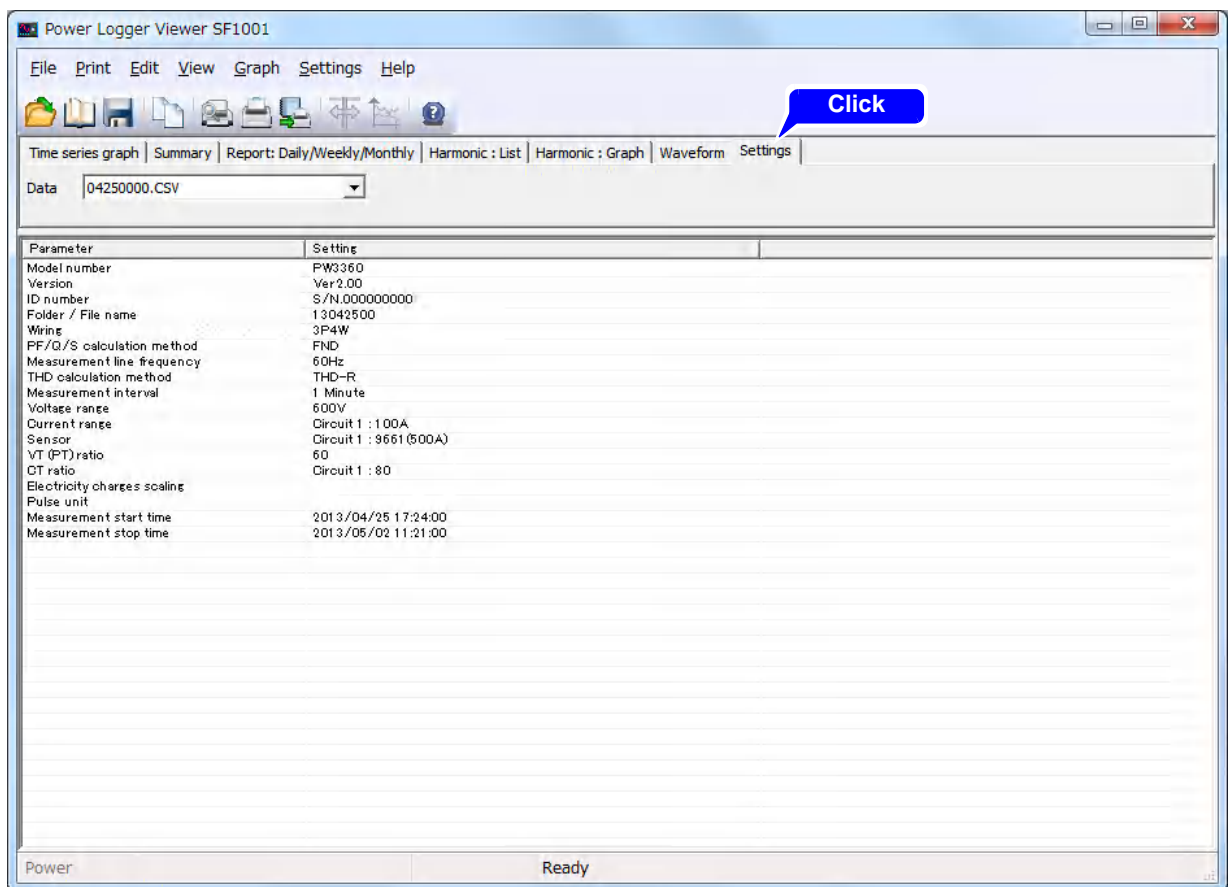

10.1 Select Measurement Data

Select the name of data to be displayed from the loaded data files.

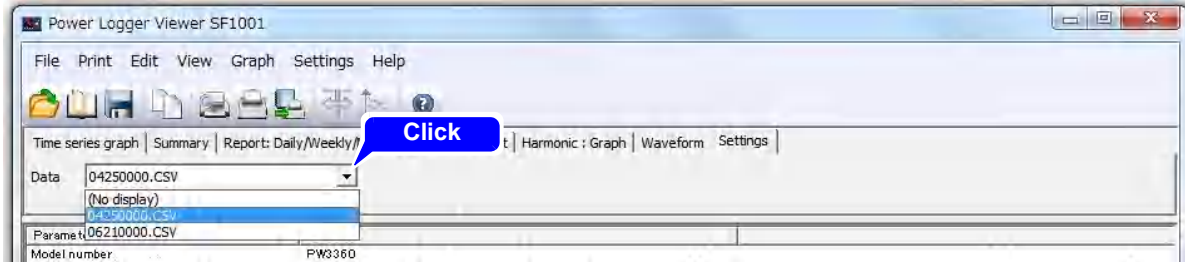

10.2 Set Column Width

Place the cursor on the right edge of the column to be adjusted; the cursor will change to a cross. Double-click to adjust the column width automatically, or click and drag the edge of the column to adjust the width manually.

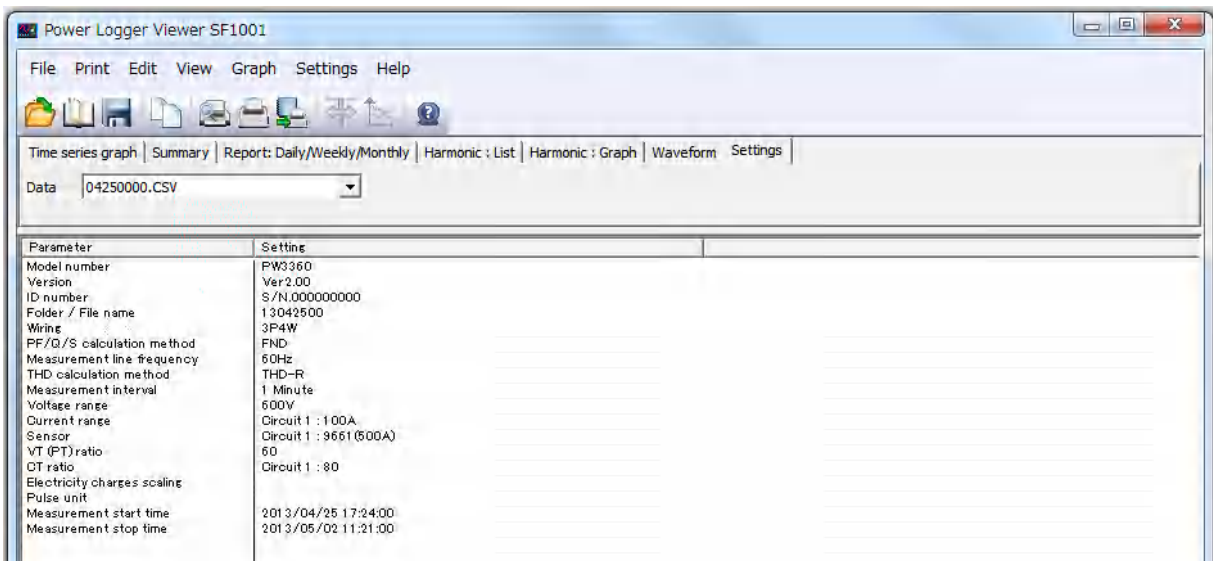

Printing Chapter 11

11.1 Printing Screens

This section describes how to print Time-series Graph, Summary, Daily/Weekly/Monthly Report, Harmonic list, Harmonic graph, waveform, and Settings screens.

1 Display the screen you wish to print.

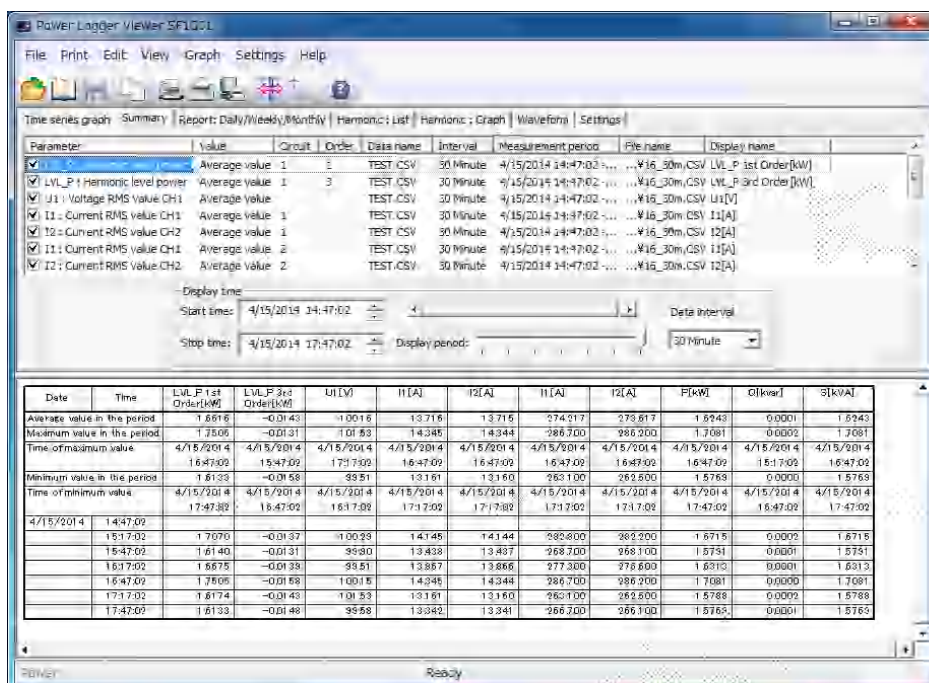

2 Select [Print]-[Header settings] on the menu bar.

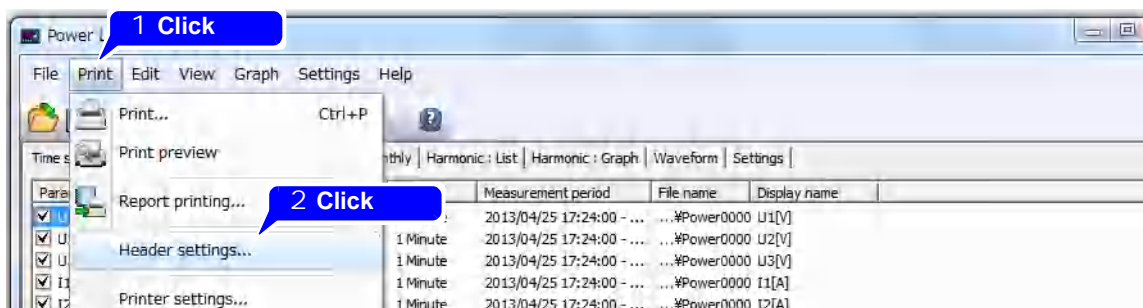

The "Header settings on the printed page" dialog will appear.

3 Enter a logo, title, and comment as necessary and click [OK].

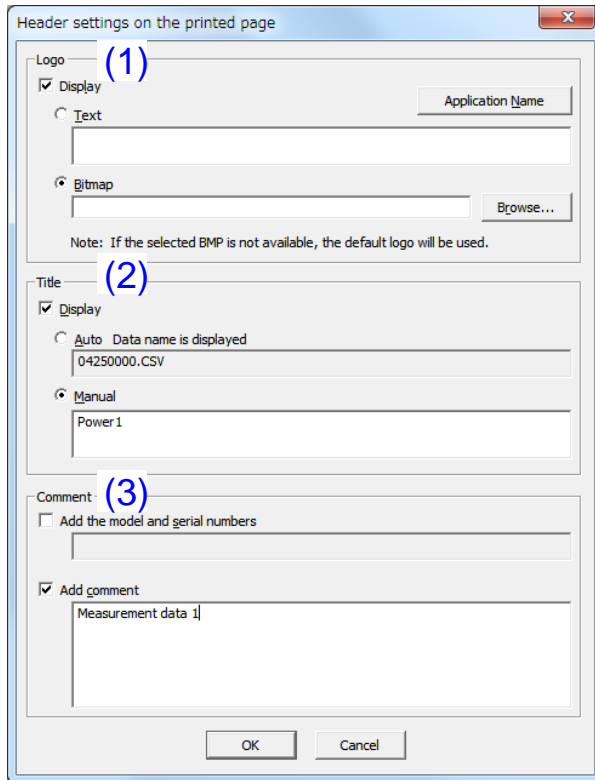

Example printout

 Time series data	Title	Power1		
	Measurement period	2013/04/25 17:24:00 - 2013/05/02 11:21:00		
	Display period	2013/04/25 17:24:00 - 2013/04/25 22:59:00		
	Measurement interval	1 Minute	Data interval	1 Minute
	Comment	Measurement data 1		

NOTE

- If [Bitmap] has been selected under [Logo] but the referenced file does not exist, the HIOKI logo will be output.
- Some characters may not be displayed if you enter four or more lines under [Comment].
- "Power Logger Viewer SF1001" will be entered in the text space when the "Application Name" button is clicked.

4 Select [Print]-[Printer settings] on the menu bar.

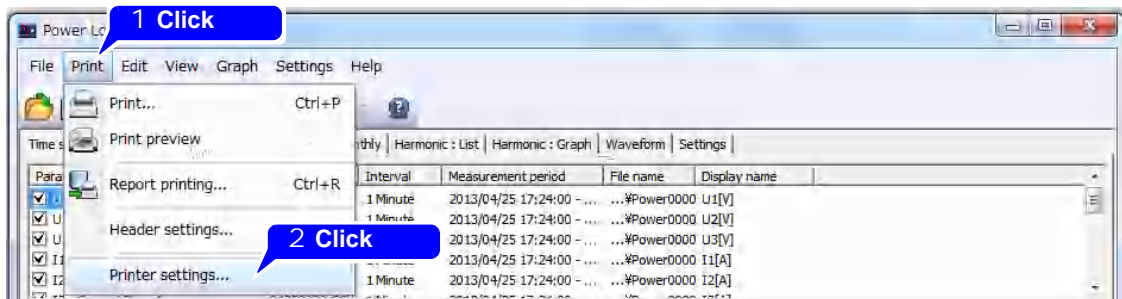

The "Print Setup" dialog will appear.

5 Set the printer name, paper size, and orientation and click [OK].

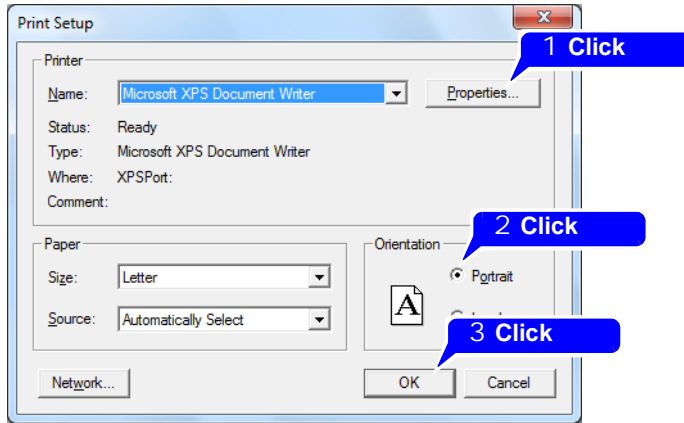

When using grayscale printing, screens may not print properly depending on the set color.

6 Click the  button. The print preview will appear.

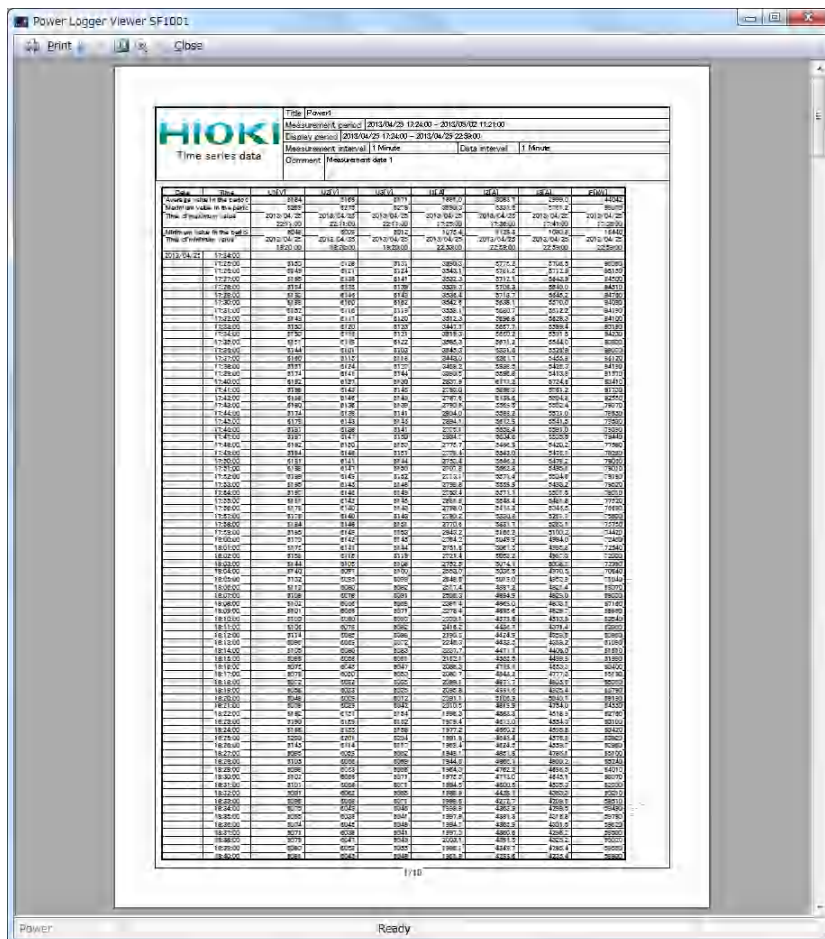

7 Check the print preview and click [Print].

11.2 Printing Reports

This section describes how to create and print reports consisting of loaded measurement data. Time-series data, daily reports, and time-series graphs based on the loaded files will be printed.

1 Select [Print]-[Header settings] on the menu bar.

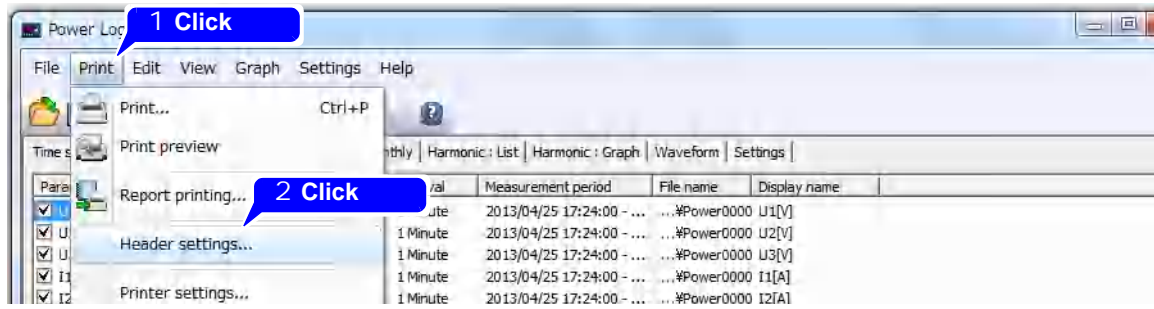

The "Header settings on the printed page" dialog will appear.

2 Enter a logo, title, and comment as necessary and click [OK].

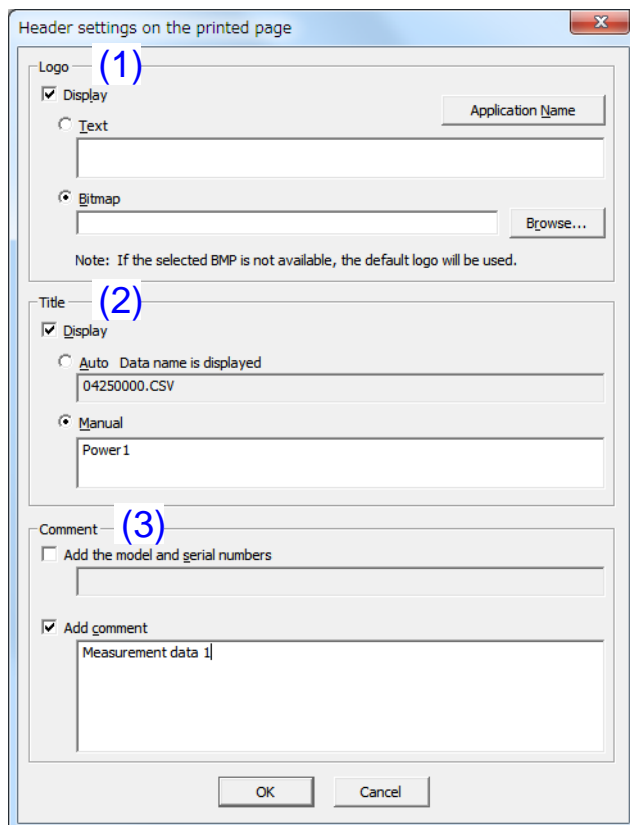

NOTE

- If [Bitmap] has been selected under [Logo] but the referenced file does not exist, the HIOKI logo will be output.
- Some characters may not be displayed if you enter four or more lines under [Comment].

Example printout

 Time series data	(1)	Title Power1
	(2)	Measurement period 2013/04/25 17:24:00 - 2013/05/02 11:21:00
	(3)	Display period 2013/04/25 17:24:00 - 2013/04/25 22:59:00
		Measurement interval 1 minute Data interval 1 Minute
		Comment Measurement data 1

3 Select [Print]-[Printer settings] on the menu bar.

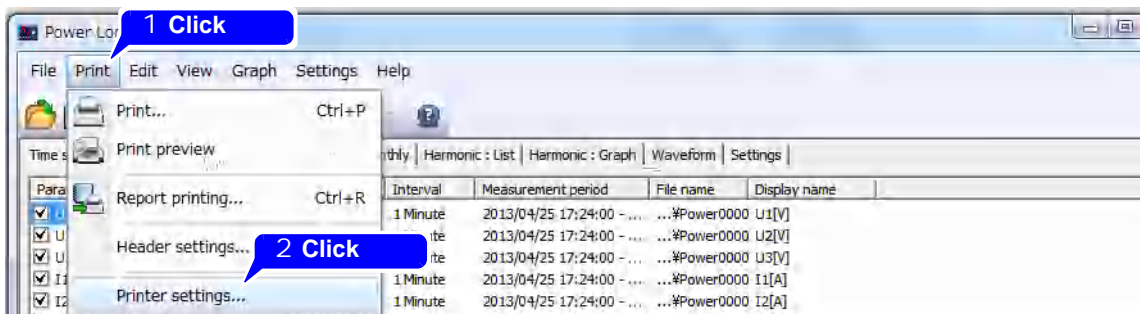

The "Print Setup" dialog will appear.

4 Set the printer name, paper size, and orientation and click [OK].

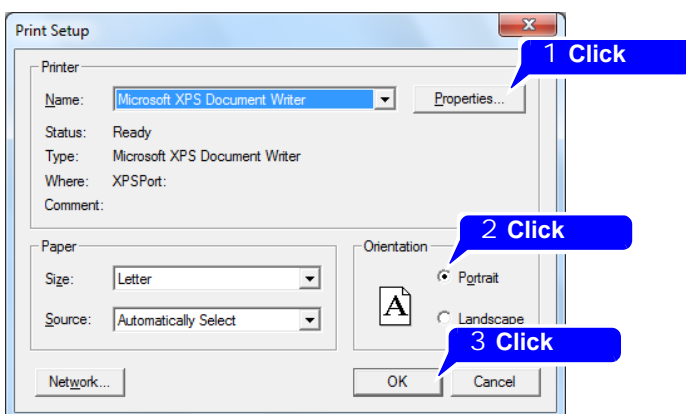

When using grayscale printing, screens may not print properly depending on the set color.

5 Click the button on the tool bar.

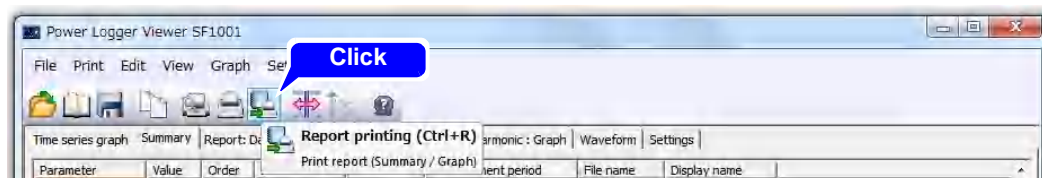

The "Report printing" dialog will appear.

6 Select the measurement mode you wish to print as the print parameter.

[Power]

Prints a summary, daily report, and time-series graph.

[Harmonic one interval]

Prints a harmonic list and harmonic graph.

Outputs the average value for the first time interval after the specified time and date. Example: If you specify 12:00:00 on 2013/07/01 with a measurement data interval of 5 minutes, the software will output the average value for the period of time from 12:00:00 on 2013/07/01 to 12:05:00 on 2013/07/01.

[Harmonic fixed period]

Prints a summary and time-series graph.

Outputs the values of the order selected with [\[Order selection\]](#).

7 Enter the print period and click [\[Next\]](#).

NOTE

When you have selected [\[Harmonic one interval\]](#) in Format, please specify a date and a time other than the beginning of the data in [\[Date / Period\]](#) because there is no value at the beginning time of the data.

8

Click the [Print].

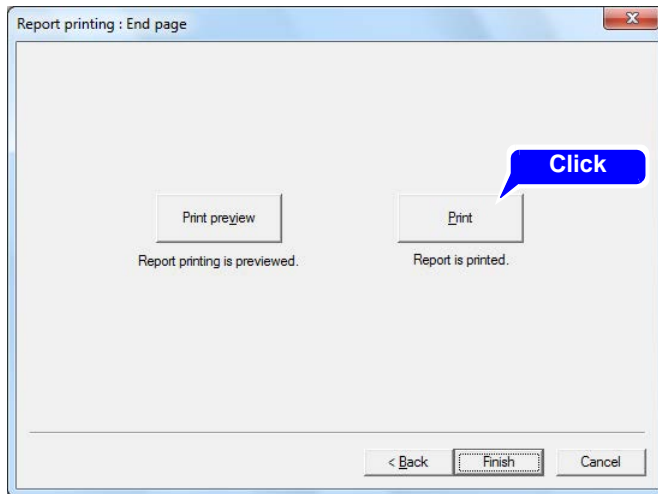

Alternately, click [Print] on the top left of the preview screen after checking it under [Print preview].

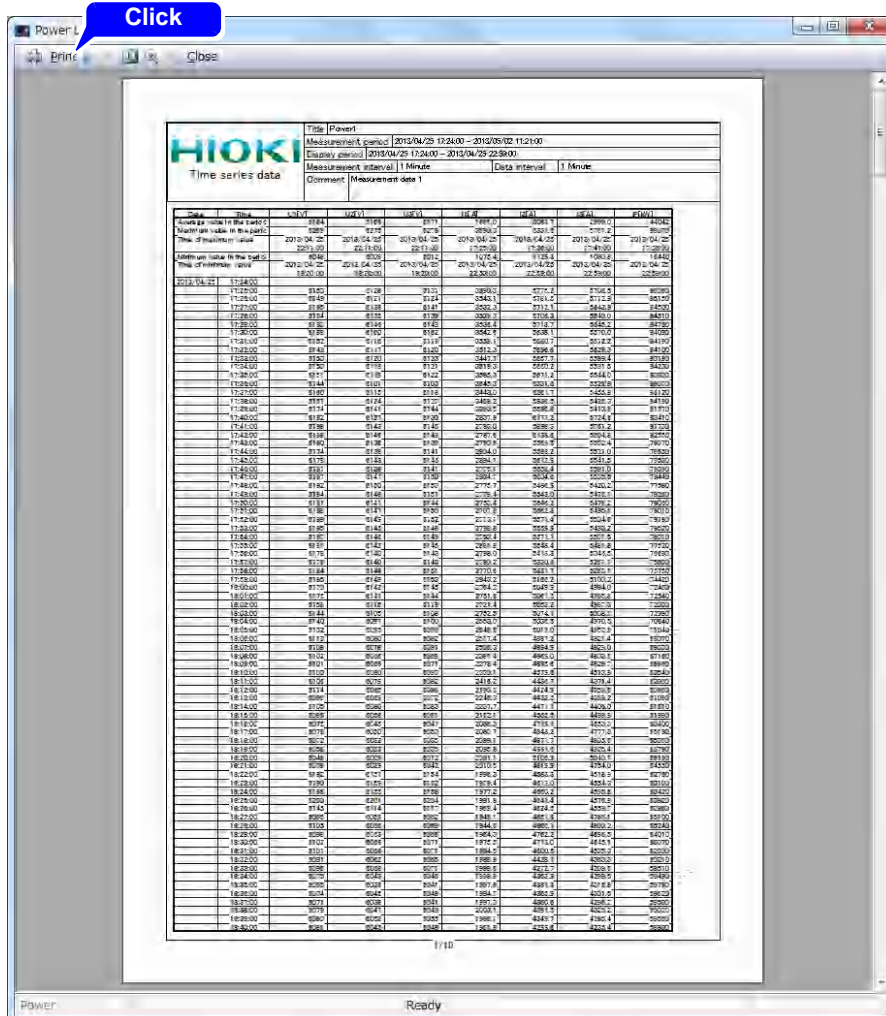

The report will be printed.

Specifications Chapter 12

12.1 General Specifications

Supported model	Model PW3360 Clamp on Power Logger Model PW3365 Clamp on Power Logger Model 3169 Clamp on Power HiTester Model 9625 Power Meas. Support Software Data Logger series
System requirements	Personal computer satisfying the following requirements: OS : English version, Japanese version, or Chinese version : WindowsXP SP3 or more (32bit version) : WindowsVista SP2 or more (32bit version) : Windows7 SP1 or more (32/64bit version) : Windows8/8.1 (32/64bit version) CPU : 1.0 GHz or more (2.0 GHz or more recommended) Memory : 1.0 GHz or more (2.0 GHz or more recommended) *For Windows 7 (64-bit version) or Windows 8/8.1 (64-bit version), 2.0 GB or more Hard-disk space : Free disk space of 128 MB or more (at launch) Display : Resolution 1024 x 768 dots or more, 65536 colors or more Disk drive : CD-ROM drive (used for installation)
Supplied media	One application disc

12.2 Functional Specifications

Load/Save function

Loadable data formats	Model PW3360	: Measurement data file (Extension .CSV, CSV format) Harmonic-measurement data file (Extension .HRM, binary format) Waveform data file (Extension .WUI, binary format)
	Model PW3365	: Measurement data file (Extension .CSV, CSV format) Waveform data file (Extension .WUI, binary format)
	Model 3169	: Measurement data file (Extension .CSV, CSV format) Waveform data file (Extension .WUI, binary format) Short-term-interval data file (Extension .bin, binary format)
	Data Logger	: Recorded data file (Extension .hrp2, .ini, .bin)
	Model 9625	: Combined file (Extension .dat, binary format)
	Model SF1001	: Combined file (Extension .da2, binary format)
	Savable data formats	Model SF1001
Maximum loadable data size	For files consisting of only data in CSV format and not including those in binary format: 4 GB For files including data in binary format: 2GB	
Maximum number of data sets that can be loaded	16	

Time-Series graph display

Graphic display item	Voltage RMS value/ current RMS value/ voltage fundamental wave value/ current fundamental wave value/ voltage waveform peak/ current waveform peak/ voltage fundamental wave phase angle/ current fundamental wave phase angle/ voltage unbalance factor/ active power/ reactive power/apparent power/power factor or displacement power factor/ frequency/ active energy (consumption, regeneration)/ reactive energy (lag, lead)/ active power demand value (consumption, regeneration)/ reactive power demand value (lag, lead)/ active power demand value (consumption, regeneration)/ reactive power demand value (lag, lead)/ power factor demand value/ electricity charges/pulse input value/ harmonic level (voltage, current, and power)/ harmonic content percentage (voltage, current, and power)/ harmonic phase angle (voltage, current, and power)/ total harmonic distortion (voltage, current) (THD-F, THD-R)	
Y-axis upper/lower-limit setting	Automatic calculation/user specification of graph vertical axis (Y-axis) display	
Interval setting	Selectable from 1 cycle/0.1 sec/0.2 sec/0.5 sec/1 sec/2 sec/5 sec/10 sec/15 sec/30 sec/1 min/2 min/5 min/10 min/15 min/20 min/30 min/1 hour/2 hour/3 hour/4 hour/6 hour/8 hour/12 hour/1 day	
Display-period setting	The analysis start date and stop date are selectable during the overall period of the measurement data. <ul style="list-style-type: none"> Analysis start date (year/month/day/hour/min/sec): Enter appropriate numbers. Analysis stop date (year/month/day/hour/min/sec): Enter appropriate numbers. Period of measurement data (from the measurement start date to the stop date) may be displayed.	
Reference-value setting	The set reference value is displayed.	
Graph type selection	Line graph, bar graph and Stacked bar graphs	
Line style/color setting	Line style and line color are selectable separately for each piece of data. Marker display is available.	

Time-Series graph display

±1 center power factor display	Graph center is ±1, upper limit value +0, lower limit value -0.
Stacked bar graph display	Displays a stacked bar graph of up to 16 pieces of data (demand quantity and demand value only)
Cursor measurement	Displays the measurement of a point selected using the cursor
Data-display unit setting	The SI prefix (m, k, M, G, etc.) is set, and values are displayed accordingly.

Summary function

Display-item selection	Select items to be displayed on the summary *Display parameters are same as graph display parameters.
Daily, weekly, and monthly report	Sums up the data of a selected period and displays a daily, weekly, or monthly report *Excluding harmonic wave (level/content percentage/phase angle) and total harmonic distortion.
Load-factor calculation	Calculates the load factor/demand factor of a daily, weekly or monthly report, and displays the result.
Total per time segment	Divides one day into a maximum of four segments, and sums up the data of each segment.
Conversion and display of electric charges	Converts power readings to electric charges using the specified coefficient and displays the result. (as a reference value)
CO ₂ conversion display	Display the integrated active power (kWh) in CO ₂ according to the conversion rate. (as a reference value)

Harmonic Display function

List display	Displays a list of the harmonic data for a selected date
Graphic display	Displays a graph of the harmonic data for a selected date
Cursor measurement	Cursor measurement is available in the graphic display

Waveform display function

Waveform display	Displays a waveform data for a selected date
Cursor measurement	Cursor measurement is available

Setting display function

Setting display	Displays a list of the current settings Reads the settings from the data file
-----------------	--

Copy function

Copying to the clipboard	Screen images can be copied to the clipboard.
--------------------------	---

Print function

Time-series graphic print	Prints the data shown by the time-series graphic display, and displays the preview
Summary print	Prints the data shown by the summary display, and displays the preview
Harmonic list print	Prints the data shown by the harmonic list display, and displays the preview
Harmonic graph print	Prints the data shown by the harmonic graph display, and displays the preview
Waveform print	Prints the data shown by the waveform display, and displays the preview
Setting print	Prints the data shown by the setting display, and displays the preview.
Comment input	Text comments can be inserted as desired during printing.
Header/footer settings	Headers and footers can be set during printing.
Printer	Any printer compatible with the OS used Any color or monochrome printer compatible with the OS used

Report printing function

Report print	Prints the selected print format.
Print format	Power/ harmonic one interval/ harmonic fixed period
[Power] output parameters	Summary/ daily report/ time-series graph
[Harmonic one interval] output parameters	Harmonic list/ harmonic graph
[Harmonic fixed period] output parameters	Summary/ time-series graph
[Power] output parameters	Voltage/ current/ active power/ reactive power/ apparent power/ power factor/ active energy (consumption)/ active power demand value (consumption)
[Harmonic one interval] harmonic list print parameters	Harmonic level/ harmonic content percentage/ harmonic phase angle
[Harmonic one interval] harmonic graph print parameters	Harmonic level/ harmonic content percentage * Axis type: LOG
[Harmonic one interval] waveform print parameters	Voltage/ current
[Harmonic fixed period] ledger print parameters	Active power/ harmonic level (power)/ total harmonic distortion (voltage)/ harmonic content percentage (voltage)/ current RMS value/ harmonic level (current)/ harmonic phase angle (power)
[Harmonic fixed period] time-series graph print parameters	Active power/ harmonic level (power)/ total harmonic distortion, content percentage (voltage)/ current RMS value/ harmonic level (current)
Summary data interval	Automatic

Other function

Application assistance	Tool tips (tool hints), etc.
Display language	Japanese/ English/ simplified Chinese

12.3 Calculation Formulas

Load Factor [%]

(Displayed by using summing results from a daily, weekly, or monthly report screen)

$$\text{Load factor} = \frac{\text{Average active power [kW]}}{\text{Maximum demand value [kW]}} \times 100 [\%]$$

- Average active power is the average of all active power measurements during the summing period.
- The maximum demand value is the largest among all demand values during the period.
- The summing period is one day for a daily report, seven days for a weekly report, and one month for a monthly report.
- The load factor above represents the degree of fluctuations of electricity demand during summing period.

Demand Factor [%]

(Displayed by using summing results from a daily, weekly, or monthly report screen)

$$\text{Demand factor} = \frac{\text{Maximum demand value [kW]}}{\text{Facility capacity [kW]}} \times 100 [\%]$$

- The maximum demand value is the largest among all demand values during the summing period.
- The summing period is one day for a daily report, seven days for a weekly report, and one month for a monthly report.
- The facility capacity is set in the Load data file dialog. Click "File" on the menu bar, and then select "Load" file to open the dialog.
- This demand factor shows how much power is used at maximum in terms of the percentage of facility capacity.

Voltage Unbalance Factor [%]

$$\text{Voltage unbalance factor} \quad U_{unb} = \frac{U_b}{U_a} \times 100 [\%]$$

$$U_a = \sqrt{\frac{1}{6}(U1^2 + U2^2 + U3^2) + \frac{2}{\sqrt{3}}\sqrt{U_s(U_s - U1)(U_s - U2)(U_s - U3)}}$$

$$U_b = \sqrt{\frac{1}{6}(U1^2 + U2^2 + U3^2) - \frac{2}{\sqrt{3}}\sqrt{U_s(U_s - U1)(U_s - U2)(U_s - U3)}}$$

$$U_s = \frac{U1 + U2 + U3}{2} \quad U1, U2, U3: \text{Line to line voltage (instantaneous or average values)}$$

- This voltage unbalance factor represents the degree of voltage unbalance between three phase lines.
- Only 3-phase/3-wire measurement data is displayed.

- Please visit our website at www.hioki.com for the following:
 - Regional contact information
 - The latest revisions of instruction manuals and manuals in other languages.
 - Declarations of Conformity for instruments that comply with CE mark requirements.
- All reasonable care has been taken in the production of this manual, but if you find any points which are unclear or in error, please contact your supplier or the International Sales and Marketing Department at Hioki headquarters.
- In the interests of product development, the contents of this manual are subject to revision without prior notice.
- The content of this manual is protected by copyright.
No reproduction, duplication or modification of the content is permitted without the authorization of Hioki E.E. Corporation.

HIOKI

HIOKI E. E. CORPORATION

HEADQUARTERS

81 Koizumi, Ueda, Nagano 386-1192, Japan
TEL +81-268-28-0562 FAX +81-268-28-0568
os-com@hioki.co.jp
(International Sales Department)

www.hioki.com

HIOKI USA CORPORATION

hioki@hiokiusa.com www.hiokiusa.com

HIOKI (Shanghai) SALES & TRADING CO., LTD.

info@hioki.com.cn www.hioki.cn

HIOKI INDIA PRIVATE LIMITED

hioki@hioki.in www.hioki.in

HIOKI SINGAPORE PTE. LTD.

info@hioki.com.sg

1502EN