

IM9100

SMD TEST FIXTURE

Instruction Manual

EN

Aug. 2018 Revised edition 3
IM9100A981-03 18-08H



HIOKI

<http://www.hioki.com>

HEADQUARTERS
81 Koizumi
Ueda, Nagano 386-1192 Japan

HIOKI EUROPE GmbH
Rudolf-Diesel-Strasse 5
65760 Eschborn, Germany
hioki@hioki.eu



Our regional
contact
information

1808EN

Edited and published by HIOKI E.E. CORPORATION

Printed in Japan

- CE declarations of conformity can be downloaded from our website.
- Contents subject to change without notice.
- This document contains copyrighted content.
- It is prohibited to copy, reproduce, or modify the content of this document without permission.
- Company names, product names, etc. mentioned in this document are trademarks or registered trademarks of their respective companies.

Warranty Certificate

HIOKI

Model	Serial number	Warranty period
		Three (3) years from date of purchase (___ / ___)

Customer name: _____
Customer address: _____

Important

- Please retain this warranty certificate. Duplicates cannot be reissued.
- Complete the certificate with the model number, serial number, and date of purchase, along with your name and address. The personal information you provide on this form will only be used to provide repair service and information about Hioki products and services.

This document certifies that the product has been inspected and verified to conform to Hioki's standards. Please contact the place of purchase in the event of a malfunction and provide this document, in which case Hioki will repair or replace the product subject to the warranty terms described below.

Warranty terms

- The product is guaranteed to operate properly during the warranty period (three [3] years from the date of purchase). If the date of purchase is unknown, the warranty period is defined as three (3) years from the date (month and year) of manufacture (as indicated by the first four digits of the serial number in YYMM format).
- If the product came with an AC adapter, the adapter is warranted for one (1) year from the date of purchase.
- The accuracy of measured values and other data generated by the product is guaranteed as described in the product specifications.
- In the event that the product or AC adapter malfunctions during its respective warranty period due to a defect of workmanship or materials, Hioki will repair or replace the product or AC adapter free of charge.
- The following malfunctions and issues are not covered by the warranty and as such are not subject to free repair or replacement:
 - Malfunctions or damage of consumables, parts with a defined service life, etc.
 - Malfunctions or damage of connectors, cables, etc.
 - Malfunctions or damage caused by shipment, dropping, relocation, etc., after purchase of the product
 - Malfunctions or damage caused by inappropriate handling that violates information found in the instruction manual or on precautionary labeling on the product itself
 - Malfunctions or damage caused by a failure to perform maintenance or inspections as required by law or recommended in the instruction manual
 - Malfunctions or damage caused by fire, storms or flooding, earthquakes, lightning, power anomalies (involving voltage, frequency, etc.), war or unrest, contamination with radiation, or other acts of God
 - Damage that is limited to the product's appearance (cosmetic blemishes, deformation of enclosure shape, fading of color, etc.)
 - Other malfunctions or damage for which Hioki is not responsible
- The warranty will be considered invalidated in the following circumstances, in which case Hioki will be unable to perform service such as repair or calibration:
 - If the product has been repaired or modified by a company, entity, or individual other than Hioki
 - If the product has been embedded in another piece of equipment for use in a special application (aerospace, nuclear power, medical use, vehicle control, etc.) without Hioki's having received prior notice
- If you experience a loss caused by use of the product and Hioki determines that it is responsible for the underlying issue, Hioki will provide compensation in an amount not to exceed the purchase price, with the following exceptions:
 - Secondary damage arising from damage to a measured device or component that was caused by use of the product
 - Damage arising from measurement results provided by the product
 - Damage to a device other than the product that was sustained when connecting the device to the product (including via network connections)
- Hioki reserves the right to decline to perform repair, calibration, or other service for products for which a certain amount of time has passed since their manufacture, products whose parts have been discontinued, and products that cannot be repaired due to unforeseen circumstances.

HIOKI E.E. CORPORATION
<http://www.hioki.com>

18-07 EN-3

Introduction

Thank you for purchasing the HIOKI IM9100 SMD Test Fixture. To obtain maximum performance from the device, please read this manual first, and keep it handy for future reference.

Verifying Package Contents

When you receive the device, inspect it carefully to ensure that no damage occurred during shipping. In particular, check the accessories and connectors. If damage is evident, or if it fails to operate according to the specifications, contact your authorized Hioki distributor or reseller.

Cleaning

To clean the device, wipe it gently with a soft cloth moistened with water or mild detergent.

IMPORTANT

Never use solvents such as benzene, alcohol, acetone, ether, ketones, thinners or gasoline, as they can deform and discolor the case.

Repair

If the device seems to be malfunctioning, contact your authorized Hioki distributor or reseller.

Disposal

Handle and dispose of the instrument in accordance with local regulations.

Safety Notes

Before using the instrument, be certain to carefully read the following safety notes.

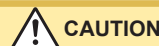

- Mishandling during use could damage to the device. Be certain that you understand the instructions and precautions in the manual before use.
- If persons unfamiliar with electricity measuring device are to use the device, another person familiar with such instruments must supervise operations.

Notation

In this manual, the risk seriousness and the hazard levels are classified as follows.

	WARNING	Indicates a potentially hazardous situation that may result in death or serious injury to the operator.
	CAUTION	Indicates a potentially hazardous situation that may result in minor or moderate injury to the operator or damage to the device or malfunction.
	IMPORTANT	Indicates information related to the operation of the device or maintenance tasks with which the operators must be fully familiar.
		Indicates cautions and hazards. When the symbol is printed on the device, refer to a corresponding topic in the Instruction Manual.
		Indicates prohibited actions.
		Indicates the action which must be performed.

Connection Method

Inspection Before Use

Before using the device, verify that it operates normally to ensure that no damage occurred during storage or shipping. If you find any damage, contact your authorized Hioki distributor or reseller.

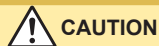

CAUTION

When disconnecting the BNC connector, be sure to release the lock before pulling off the connector. Forcibly pulling the connector without releasing the lock, can damage the BNC connector.

You will need: Phillips-head screwdriver

- 1 Align the device's BNC connectors with the instrument's BNC connectors, insert them, and lock the device in place with the lock lever.

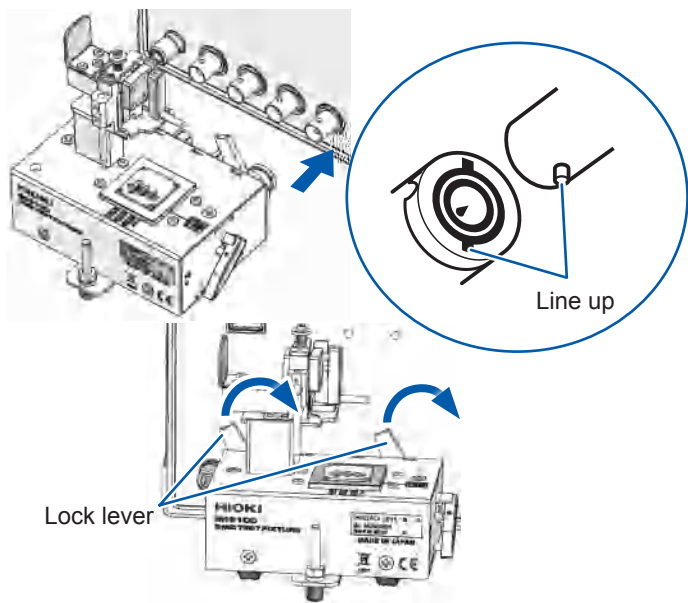

- 2 Adjust the adjustor so that the connector is not subject to excessive force.

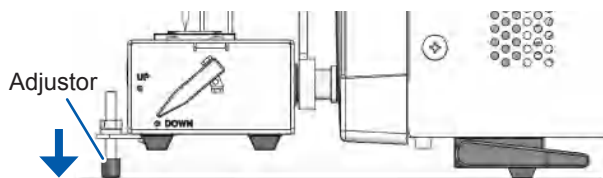

- 3 If you need to fine-tune the sample and pusher tip position, loosen the pusher fixing screws and adjust as necessary.

Retighten the fixing screws after adjustment.

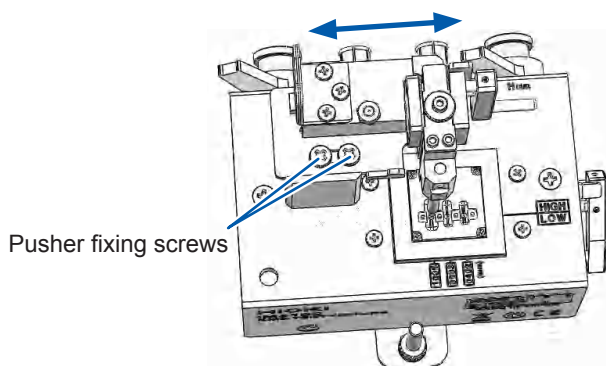

Parts Names

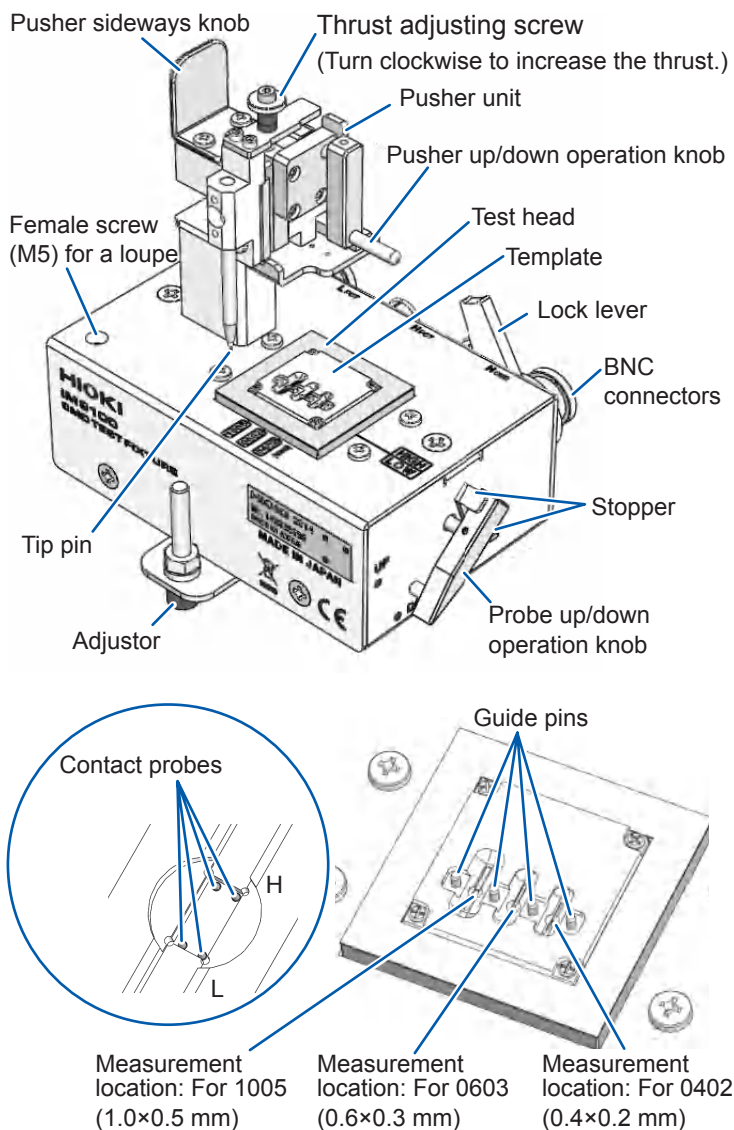

Open Correction

To reduce measurement error, open correction is performed. The correction method varies with the instrument to which the device is to be connected. See the user manual that came with the instrument.

You will need: Open correction jig, tweezers

- 1 Using the pair of tweezers, attach the open correction jig to the 1005 measurement position on the test head.

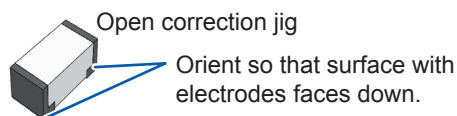

- 2 Gradually apply the tip pin to the open correction jig.
- 3 Perform correction with the instrument. For more information, see "Measurement Method" in the user manual.

IMPORTANT

Even if you will be measuring 0402- and 0603-size samples, perform open correction using the 1005 measurement position.

Symbols for various standards



This symbol indicates that the product conforms to regulations set out by the EC Directive.



WEEE marking: This symbol indicates that the electrical and electronic appliance is put on the EU market after August 13, 2005, and producers of the Member States are required to display it on the appliance under Article 11.2 of Directive 2002/96/EC (WEEE).

Usage Notes

Follow these precautions to ensure safe operation and to obtain the full benefits of the various functions.

WARNING

- Installing the instrument in inappropriate locations may cause a malfunction of instrument or may give rise to an accident. Avoid the following locations.
- Exposed to direct sunlight or high temperature
- Exposed to corrosive or combustible gases
- Exposed to water, oil, chemicals, or solvents
- Exposed to high humidity or condensation
- Exposed to a strong electromagnetic field or electrostatic charge
- Exposed to high quantities of dust particles
- Near induction heating systems (such as high-frequency induction heating systems and IH cooking equipment)
- Subject to vibration

CAUTION

- To avoid damage to the device, protect it from physical shock when transporting and handling. Be especially careful to avoid physical shock from dropping.
- Do not slant the device or place it on top of an uneven surface. Dropping or knocking down the device can cause injury or damage to the device.
- When using the IM9100 with the 9268-10 DC Bias Voltage Unit, to prevent damage to the IM9100 and the connected measuring instrument, do not short the contact probes of the test head while a DC voltage (DC bias) is being input.

IMPORTANT

- The template which fixes a sample becomes dirty and there is a possibility that a function may fall by deformation etc. When dirt adheres, please remove with soft brush, cloth, etc.
- The template, short correction jig, and open correction jig are expendable items. If there are signs of deterioration due to deformation of or other damage, contact your dealer or Hioki representative to order a new one.

Precautions during shipment

Use the original packing materials when transporting the device, if possible. Pack the device so that it will not sustain damage during shipping, and include a description of existing damage. We do not take any responsibility for damage incurred during shipping.

Overview

The IM9100 SMD Test Fixture is a test fixture for SMD components that connects directly to the measurement terminal (UNKNOWN terminal) on a HIOKI LCR meter. It allows you to perform 4-terminal measurement of three types of compact chip component (0.4 mm × 0.2 mm, 0.6 mm × 0.3 mm, and 1.0 mm × 0.5 mm).

Specifications

Operating environment	Indoors, altitude up to 2,000 m (6,562-ft.)
Operating temperature and humidity	0°C to 40°C/ 32°F to 104°F, 80% RH or less (non-condensating)
Storage temperature and humidity	-10°C to 55°C/ 14°F to 131°F, 80% RH or less (non-condensating)
Dimensions	Approx. 94W×62H×99D mm / 3.7"W×2.44"H×3.9"D (Outer dimensions with pusher on the far left. Excluding protruding parts such as the pusher up/down operation knob, BNC connectors, adjustor, and rubber legs.)
Mass	Approx. 300 g/ 10.6 oz.
Product warranty period	3 years This warranty does not apply to template, contact probes, and movable parts.
Connection to measuring instrument	4-terminal pair design Connectors: BNC (connector spacing: 22 mm/ 0.87")
Contact with sample	4-terminal design
Measurement sample size	JIS (EIA): L×W mm 0402 (01005): 0.4×0.2 mm 0603 (0201): 0.6×0.3 mm 1005 (0402): 1.0×0.5 mm
Maximum input voltage	±42 V peak (AC+DC)
Maximum input current	0.15 A rms (±0.15 ADC)
Usable frequency range	DC to 8 MHz
Residual parameter values (reference values)	Capacitance: 1.5 pF or less Inductance: 100 nH or less Resistance: 50 mΩ or less
Accessories	• Instruction Manual ×1 • Short correction jig ×1 (used for all component sizes) • Open correction jig ×2 (1005 size: The 1005 size is used for all sizes.) Residual parameter values (reference values) : Less than 50 fF

Short Correction

To reduce measurement error, short correction is performed. The correction method varies with the instrument to which the device is to be connected. See the user manual that came with the instrument.

CAUTION

- To prevent damage to contact probes, lower the contact probe with the probe up/down operation knob when attaching or removing the template.
- When attaching the template, insert it so that the fixing screws pass straight through the screw holes and tighten it in place using an appropriate amount of force. Over-tightening may damage the screw holes.
- Screw tightening torque: Max. 0.015 N·m

You will need: No. 0 precision Phillips-head screwdriver, short correction jig

Removing the template

- 1 Remove the screws holding the template in place.
- 2 Lift off the template to remove it.

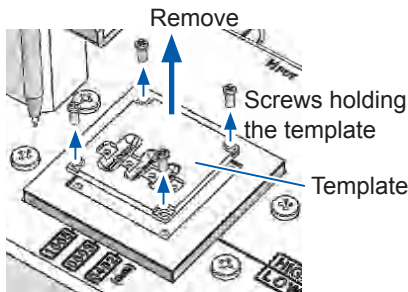

Attaching the short correction jig and performing correction

- 1 Pass the guide pins through the holes in the short correction jig and attach it at the position corresponding to the size of sample to be measured.

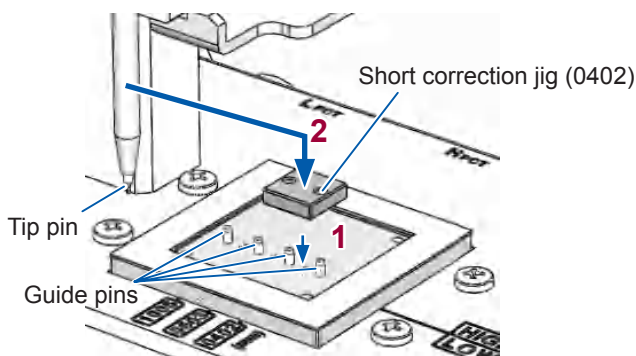

- 2 Move the pusher unit to the short correction jig's position.
- 3 Turn the pusher up/down operation knob in the "down" direction to gradually lower the tip pin until it comes into contact with the short jig.
- 4 Turn the probe up/down operation knob in the "up" direction to raise the contact probe.
- 5 Perform correction with the instrument.

Attaching the template

After performing short correction, reattach the template as it was attached before.

Measurement Method

CAUTION

- To prevent damage to the device and samples, lower the contact probe with the probe up/down operation knob when attaching samples. Additionally, apply the tip pin to samples gradually so as not to subject them to excessive force.
- Do not apply the tip pin to the contact probe without first attaching a sample.
- To avoid damaging the tip pin, do not move the pusher unit horizontally while the pusher is in the lowered position.

You will need: Tweezers

Preparing for Measurement

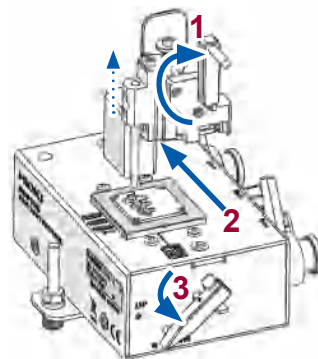

- 1 Turn the pusher up/down operation knob in the "up" direction to raise the tip pin.
- 2 Using the pusher sideways knob, move the pusher unit in the direction of the arrow.
- 3 Lower the probe up/down operation knob to lower the contact probe.
(This step can also be performed before Step 1 above.)

Attaching the sample

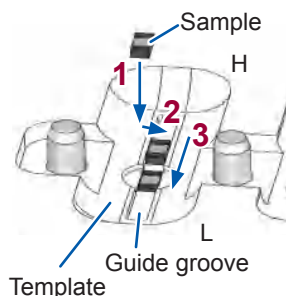

- 1 Place the sample on the template using a pair of tweezers. Align the sample's electrodes with the H and L contacts on the template and be sure that it is placed right side up, etc.
- 2 Move the sample to the guide groove.
- 3 Place the sample in the measurement location's square hole.

IMPORTANT

To ensure accurate measurement, remove samples from other measurement locations before performing measurement.

Securing and measuring the sample

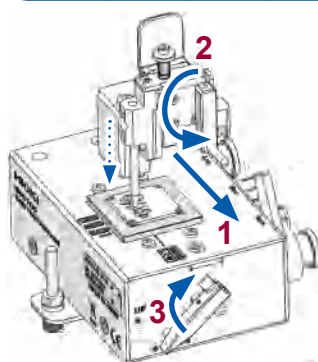

- 1 Using the pusher sideways knob, move the pusher unit to the location of the sample.
- 2 Turn the pusher up/down operation knob to gradually lower the tip pin until it comes into contact with the sample.
- 3 Raise the probe up/down operation knob to raise the contact probe.
- 4 Perform measurement with the instrument.

Completing measurement

After measurement is complete, remove the sample by reversing the steps used to secure it in place. Raise the pusher up/down operation knob until it comes into contact with the stopper before moving the pusher unit horizontally.