



# Transpector<sup>®</sup> XPR 3+

## Gas Analysis System

PN 074-687-P1A





**EU DECLARATION  
OF  
CONFORMITY**

This declaration is issued under the sole responsibility of the manufacturer INFICON. The object of the declaration is to certify that this equipment, designed and manufactured by:

**INFICON Inc.  
Two Technology Place  
East Syracuse, NY 13057  
USA**

is in conformity with the relevant Community harmonization legislation. It has been constructed in accordance with good engineering practice in safety matters in force in the Community and does not endanger the safety of persons, domestic animals or property when properly installed and maintained and used in applications for which it was made.

Equipment Description:	Transpector® XPR 3+ Gas Analysis System
Applicable Directives:	2014/35/EU (LVD) 2014/30/EU (EMC) 2011/65/EU (RoHS)
Applicable Standards:	
Safety:	EN 61010-1:2010 Safety Requirements for Electrical Equipment For Measurement, Control, and Laboratory Use. Part 1: General Requirements
Emissions:	EN 61326-1:2013 (Radiated & Conducted Emissions) (EMC – Measurement, Control & Laboratory Equipment) EN 55011:2009/A1:2010 Group 2, Class A ICES-001 Issue 4 ISM emissions requirements (Canada) FCC 47 CFR Part 18 Class A emission requirement (USA)
Immunity:	EN 61326-1:2013 (General EMC) Class A: Immunity (EMC – Measurement, Control & Laboratory Equipment)
RoHS:	Fully compliant

CE Implementation Date: June 21, 2017

Authorized Representative:

Stephen Chabot  
VP of Operations & Quality  
INFICON Inc.

ANY QUESTIONS RELATIVE TO THIS DECLARATION OR TO THE SAFETY OF INFICON'S PRODUCTS SHOULD BE DIRECTED, IN WRITING, TO THE AUTHORIZED REPRESENTATIVE AT THE ABOVE ADDRESS.

## **Trademarks**

The trademarks of the products mentioned in this manual are held by the companies that produce them.

INFICON<sup>®</sup>, Transpector<sup>®</sup> and FabGuard<sup>®</sup> are registered trademarks of INFICON GmbH.

Windows<sup>®</sup>, and Microsoft<sup>®</sup> are registered trademarks of Microsoft Corporation.

All other brand names, product names or trademarks belong to their respective holders.

## **Software Copyrights**

This product contains embedded software protected under the following copyrights:

Copyright INFICON Inc.

## **Disclaimer**

The information contained in this Operating Manual is believed to be accurate and reliable. However, INFICON assumes no responsibility for its use and shall not be liable for any special, incidental, or consequential damages related to the use of this product.

Due to our continuing program of product improvements, specifications are subject to change without notice.

## **Copyright**

©2017 All rights reserved.

Reproduction or adaptation of any part of this document without permission is unlawful.

# Table Of Contents

- Trademarks
- Software Copyrights
- Disclaimer
- Copyright

## Chapter 1

### Getting Started

- 1.1 Introduction . . . . . 1-1
- 1.2 Using This Manual . . . . . 1-1
  - 1.2.1 Note and Hint Paragraphs . . . . . 1-1
  - 1.2.2 Warning and Caution Paragraphs . . . . . 1-2
- 1.3 How To Contact Customer Support . . . . . 1-2
  - 1.3.1 Returning Transpector XPR 3+ to INFICON . . . . . 1-3
- 1.4 Quick Start . . . . . 1-3
- 1.5 Purpose of Transpector XPR 3+ Gas Analysis System . . . . . 1-3
- 1.6 General Description of Transpector XPR 3+ Gas Analysis System . . . . . 1-4
- 1.7 Specifications for Transpector XPR 3+ Gas Analysis System . . . . . 1-4
- 1.8 Supplied Items . . . . . 1-4
- 1.9 Physical Requirements . . . . . 1-5
  - 1.9.1 Physical Dimensions . . . . . 1-5
  - 1.9.2 Weight . . . . . 1-6
  - 1.9.3 Mounting Requirements . . . . . 1-6
  - 1.9.4 Ventilation Requirements . . . . . 1-6
  - 1.9.5 Maintenance Access . . . . . 1-6
- 1.10 Electrical Power Requirements . . . . . 1-6
  - 1.10.1 Required Supply Voltage . . . . . 1-6
  - 1.10.2 Current Rating . . . . . 1-6
  - 1.10.3 Electrical Connection . . . . . 1-6
- 1.11 Overvoltage Category . . . . . 1-7
- 1.12 Required Vacuum . . . . . 1-7
- 1.13 Environmental Requirements . . . . . 1-7
  - 1.13.1 Use . . . . . 1-7
  - 1.13.2 Altitude Range . . . . . 1-7
  - 1.13.3 Pollution Degree . . . . . 1-7
  - 1.13.4 Operating Temperature . . . . . 1-8

1.13.5	Humidity . . . . .	1-8
1.14	Computer System Requirements . . . . .	1-8
1.15	Software Installation . . . . .	1-8
1.16	Hardware Installation . . . . .	1-8
1.16.1	Avoiding Process Metal Deposition . . . . .	1-9
1.16.2	Installing the Isolation Valve . . . . .	1-11
1.16.3	Mounting the Pirani Interlock Weldment Assembly . . . . .	1-17
1.16.4	Mounting the Pirani Gauge . . . . .	1-18
1.16.5	Sensor Installation . . . . .	1-19
1.16.6	Electronics Module Installation . . . . .	1-22
1.16.7	Initial Start-up Procedure . . . . .	1-23
1.16.8	Installing Ethernet Communications . . . . .	1-23
1.16.9	Connecting the 24 V(dc) Power Supply . . . . .	1-24
1.16.10	Connecting the Pirani Interlock Cable . . . . .	1-24
1.16.11	Attaching Heating Jackets . . . . .	1-25
1.17	Input/Output (I/O) . . . . .	1-25
1.17.1	Two Digital Inputs . . . . .	1-26
1.17.2	One Status Relay Output . . . . .	1-26
1.17.3	One Analog Input . . . . .	1-28

## **Chapter 2**

### **Connecting Transpector XPR 3+**

2.1	Introduction . . . . .	2-1
2.2	General Networking Information . . . . .	2-1
2.2.1	IP Addresses . . . . .	2-1
2.2.2	Subnetworking . . . . .	2-3
2.3	Transpector XPR 3+ IP Address . . . . .	2-3
2.3.1	Changing Transpector XPR 3+ IP Address . . . . .	2-3
2.4	Connecting Transpector XPR 3+ . . . . .	2-10
2.4.1	Connecting a Single Transpector XPR 3+ . . . . .	2-11
2.4.2	Installing Multiple Transpector XPR 3+ Sensors . . . . .	2-11

## **Chapter 3**

### **How The Instrument Works**

3.1	Introduction . . . . .	3-1
3.2	Overview . . . . .	3-1
3.3	Patents . . . . .	3-1
3.4	Sensor . . . . .	3-3
3.4.1	The Ion Source . . . . .	3-5
3.4.2	The Quadrupole Mass Filter . . . . .	3-6
3.4.3	The Ion Detector . . . . .	3-8

3.5	Scanning Characteristics . . . . .	3-10
3.6	The Zero Blast . . . . .	3-11
3.7	High Pressure Effects. . . . .	3-11

## Chapter 4

### Applications Guide

4.1	How to Interpret the Result. . . . .	4-1
4.1.1	Qualitative Interpretation of Mass Spectra . . . . .	4-1
4.1.2	Quantitative Interpretation of Mass Spectra (Calculating Partial Pressures). . . . .	4-9
4.1.3	Additional Information for Interpreting Mass Spectra . . . . .	4-15

## Chapter 5

### Transpector XPR 3+ Operation and Best Known Methods

5.1	Introduction. . . . .	5-1
5.2	Precautions for Operation . . . . .	5-2
5.3	Pirani Interlock Protection . . . . .	5-2
5.4	FabGuard Control. . . . .	5-2
5.4.1	Transpector XPR 3+ Configuration— I/O Tab. . . . .	5-2
5.4.2	Transpector XPR 3+ BKM for Pirani Interlock Operation. . . . .	5-6
5.5	Using Transpector XPR 3+ . . . . .	5-7
5.5.1	Leak Detection . . . . .	5-7
5.5.2	Recipe Generation . . . . .	5-7
5.5.3	Mass Scale Tuning. . . . .	5-8
5.5.4	Transpector XPR 3+ Filament . . . . .	5-8
5.5.5	High Pressure Electron Multiplier. . . . .	5-8

## Chapter 6

### Transpector XPR 3+ Low Pressure EM

6.1	Introduction. . . . .	6-1
6.2	Transpector XPR 3+ Filament Caution . . . . .	6-1
6.3	Electron Multiplier Caution . . . . .	6-1
6.4	Quick Start . . . . .	6-2
6.5	Purpose of the Transpector XPR 3+ Low Pressure EM Option Gas Analysis System . . . . .	6-2
6.6	General Description of Transpector XPR 3+ Low Pressure EM Option Gas Analysis System . . . . .	6-3
6.7	Specifications for Transpector XPR 3+ Low Pressure EM Option Gas Analysis System . . . . .	6-4
6.8	Supplied Items . . . . .	6-5
6.9	XPR 3+ Low Pressure EM Installation . . . . .	6-5
6.10	XPR 3+ Low Pressure EM Operation. . . . .	6-5

## Chapter 7

### Maintenance

7.1	Introduction . . . . .	7-1
7.2	Safety Considerations . . . . .	7-1
7.2.1	Toxic Material . . . . .	7-1
7.2.2	Radiation . . . . .	7-1
7.2.3	Electrical Voltages . . . . .	7-2
7.3	General Instructions For All Repair Procedures . . . . .	7-2
7.4	Maintenance Procedures . . . . .	7-3
7.4.1	Bakeout of Quadrupole . . . . .	7-3
7.4.2	Spare Heating Jacket Part Numbers . . . . .	7-3
7.5	Repair Procedures . . . . .	7-4
7.5.1	Tools Required . . . . .	7-4
7.5.2	How to Determine if a Filament Kit Replacement is Required . . . . .	7-5
7.5.3	Filament Kit Replacement . . . . .	7-5
7.5.4	How to Determine the Condition of the Ion Source . . . . .	7-7
7.6	Mass Calibration . . . . .	7-9
7.6.1	Mass Alignment . . . . .	7-9
7.7	Pirani Interlock Adjustment Procedures . . . . .	7-10
7.7.1	INFICON PSG500 Adjustment Instructions . . . . .	7-10

## Chapter 8

### Diagnosing Problems

8.1	Introduction . . . . .	8-1
8.2	Symptom-Cause-Remedy Chart . . . . .	8-1
8.3	Communication Problems . . . . .	8-6

## Chapter 9

### Bibliography

## Chapter 10

### Glossary

## Chapter 11

### Transpector XPR 3+ Accessories and Spare Parts

11.1	Introduction . . . . .	11-1
11.2	Transpector XPR 3+ Accessories . . . . .	11-1
11.3	Transpector XPR 3+ Spare Parts . . . . .	11-2
11.3.1	Preventative Maintenance Parts . . . . .	11-2
11.3.2	Replacement Spare Parts . . . . .	11-2

## Chapter 12

### Specifications

12.1	Introduction . . . . .	12-1
12.2	Mass Range . . . . .	12-1
12.3	Detector Type . . . . .	12-1
12.4	Resolution . . . . .	12-1
12.5	Temperature Coefficient . . . . .	12-1
12.6	Sensitivity . . . . .	12-2
12.7	Minimum Detectable Partial Pressure . . . . .	12-2
12.8	Maximum Operating Pressure . . . . .	12-2
12.9	Maximum Sensor Operating Temperature . . . . .	12-2
12.10	Maximum Bakeout Temperature . . . . .	12-3
12.11	Operating Temperature . . . . .	12-3
12.12	Power Input . . . . .	12-3
12.13	Ethernet Communication Interface . . . . .	12-3
12.14	Relay Outputs . . . . .	12-3
12.15	Inputs . . . . .	12-3
12.16	Indicators (Green) . . . . .	12-3

## Chapter 13

### Supplied Items

13.1	Introduction . . . . .	13-1
13.1.1	Ship Kit . . . . .	13-1
13.1.2	Electronics Module . . . . .	13-2
13.1.3	Power Supply . . . . .	13-2
13.1.4	Sensor . . . . .	13-3
13.1.5	Software . . . . .	13-3
13.1.6	Heating Jacket System (Optional) . . . . .	13-3
13.1.7	Interlock Kit (Optional) . . . . .	13-3
13.1.8	Angle Valve (Optional) . . . . .	13-4

## Index



# Chapter 1

## Getting Started

---

### 1.1 Introduction

Transpector XPR 3+ Gas Analysis System is a quadrupole-based mass spectrometer Residual Gas Analysis (RGA) instrument designed for use in high vacuum environments, up to 20 mTorr, for monitoring trace contaminants and process gases. Transpector XPR 3+ runs with the Windows® operating system using a member of the FabGuard® suite of programs.

This chapter provides an overview of Transpector XPR 3+ Gas Analysis System. Topics include:

- ◆ the purpose of Transpector XPR 3+
- ◆ specifications
- ◆ a list of supplied items
- ◆ installation instructions
- ◆ customer support contact information.

Software information can be found either in the FabGuard Explorer Operating Manual (PN 074-528-P1) or in the FabGuard help files (for all other FabGuard programs).

### 1.2 Using This Manual

Please read this Operating Manual before operating Transpector XPR 3+.

#### 1.2.1 Note and Hint Paragraphs

**NOTE:** This is a note paragraph. Notes provide additional information about the current topic.

**HINT:** This is a hint paragraph. Hints provide insight into product usage.

### 1.2.2 Warning and Caution Paragraphs

The following Caution and Warning paragraphs are used to alert the reader of actions which may cause either damage to the instrument or bodily injury.



#### **CAUTION**

---

**This is an example of a Caution paragraph. It cautions against actions which may cause an instrument malfunction or the loss of data.**

---



#### **WARNING**

---

**This is an example of a General Warning paragraph. It warns against actions which may cause bodily injury.**

---



#### **WARNING - Risk Of Electric Shock**

---

**This is an example of a Electrical Warning paragraph. It warns of the presence of electrical voltages which may cause bodily injury.**

---

### 1.3 How To Contact Customer Support

Worldwide customer support information is available under **Contact >> Support Worldwide** at [www.inficon.com](http://www.inficon.com):

- ◆ Sales and Customer Service
- ◆ Technical Support
- ◆ Repair Service

If you are experiencing a problem with Transpector XPR 3+, please have the following information readily available:

- ◆ the Transpector XPR 3+ serial number
- ◆ a description of the problem
- ◆ an explanation of any corrective action already attempted
- ◆ the exact wording of any error messages

### 1.3.1 Returning Transpector XPR 3+ to INFICON

Do not return any component of Transpector XPR 3+ to INFICON before speaking with a Customer Support Representative and obtaining a Return Material Authorization (RMA) number. Transpector XPR 3+ will not be serviced without an RMA number.

Prior to being given an RMA number, a Declaration Of Contamination (DOC) form may need to be completed if the sensor has been exposed to process materials. DOC forms must be approved by INFICON before an RMA number is issued. INFICON may require that the sensor be sent to a designated decontamination facility, not to the factory.

## 1.4 Quick Start

Read this Operating Manual in full prior to operating Transpector XPR 3+. Then, follow the steps below to quickly start using Transpector XPR 3+.

- 1 Ensure that all supplied items have been received. See [Chapter 13, Supplied Items](#).
- 2 Install the hardware. See [section 1.16, Hardware Installation, on page 1-8](#).
- 3 Install the communication cable. See [section 1.16.8, Installing Ethernet Communications, on page 1-23](#).
- 4 Install the software. Refer to the FabGuard Explorer Operating Manual for information on installing the software.

**NOTE:** Transpector XPR 3+ requires FabGuard version 17.04.00 or higher for operation.

## 1.5 Purpose of Transpector XPR 3+ Gas Analysis System

Transpector XPR 3+ Gas Analysis System is a quadrupole-based residual gas analyzer that operates at Physical Vapor Deposition (PVD) process pressures and has an Electron Multiplier that can operate at 20 mTorr operating pressures. The miniature quadrupole sensor analyzes gases by:

- ♦ ionizing some of the gas molecules
- ♦ separating the ions by their mass-to-charge ratio
- ♦ measuring the quantity of ions at each mass

The masses, unique for each substance, allow the identification of the gas molecules from which the ions were created. The magnitudes of these signals are used to determine the partial pressures (amounts) of the respective gases. Transpector XPR 3+ measures major components and impurities in a process with a 10 ppm detection limit.

Transpector XPR 3+ is an important aid in the efficient use of a high-vacuum system, detecting leaks, and contaminants. It can indicate the partial pressures of gases in processes occurring within a vacuum or other vessel, and therefore, can be used to investigate the nature of a process or monitor process conditions.

## **1.6 General Description of Transpector XPR 3+ Gas Analysis System**

Transpector XPR 3+ Gas Analysis System is comprised of three parts:

### **Sensor**

The sensor, which functions only in a high-vacuum environment with pressures below  $2 \times 10^{-2}$  Torr ( $2.66 \times 10^{-2}$  mbar) [2.66 Pascals].

The sensor itself is comprised of three components:

- ◆ the ion source (ionizer)
- ◆ the quadrupole mass filter
- ◆ the ion detector

The sensor is mounted on an electrical feedthrough flange, which is bolted to the vacuum chamber where the gas analysis measurements are made.

### **Electronics Module**

The electronics module controls the sensor and communicates to the operating computer. The electronics module and sensor are sold matched in sets. The electronics module attaches to and is supported by the sensor.

### **Software**

The software controls the electronics module and displays the data from the sensor.

## **1.7 Specifications for Transpector XPR 3+ Gas Analysis System**

See [Chapter 12](#) for Transpector XPR 3+ Gas Analysis System specifications.

## **1.8 Supplied Items**

See [Chapter 13](#) for items that are packaged with Transpector XPR 3+ Gas Analysis System.

## 1.9 Physical Requirements

The following sections show the physical dimensions, weight, mounting requirements, ventilation requirements, and the perimeter required for maintenance access for Transpector XPR 3+.

### 1.9.1 Physical Dimensions

Figure 1-2 shows the overall physical dimensions of Transpector XPR 3+ in inches [millimeters].

Figure 1-1 Sensor dimensions

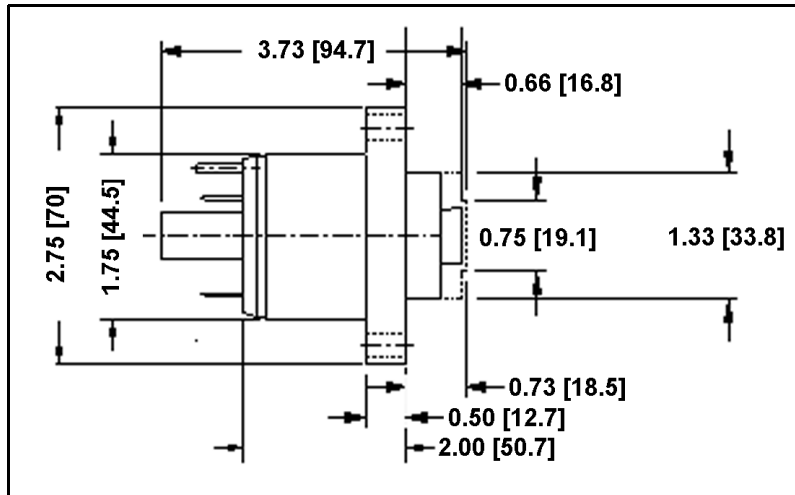
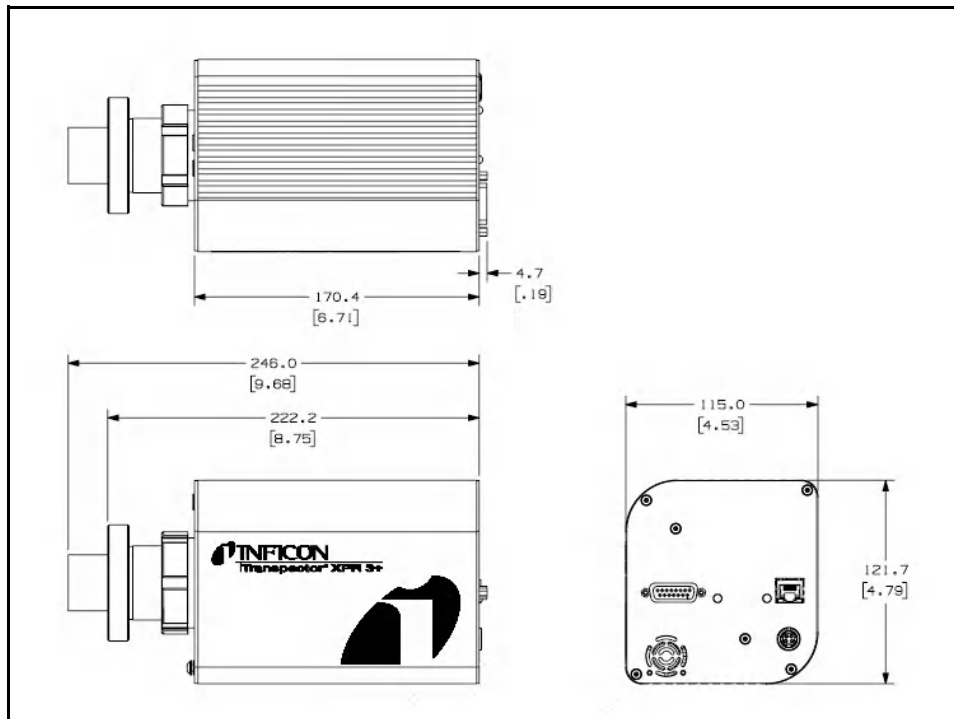


Figure 1-2 Physical dimensions of Transpector XPR 3+



### **1.9.2 Weight**

Transpector XPR 3+ electronics module weighs 1.62 kg (3.58 lbs).

### **1.9.3 Mounting Requirements**

The sensor is mounted to a high-vacuum chamber with a standard 2.75 in. (69.9 mm) O.D. ConFlat flange.

The electronics module attaches to and is supported by the sensor.

Transpector XPR 3+ can be mounted in any position. See [section 1.16.5, Sensor Installation, on page 1-19](#) for information on installing Transpector XPR 3+ system.

### **1.9.4 Ventilation Requirements**

At least 25.4 mm (1 in.) of open space around the Transpector XPR 3+ electronics module must be maintained for proper ventilation.

### **1.9.5 Maintenance Access**

Easy access to Transpector XPR 3+ should be maintained for installation and maintenance activities.

## **1.10 Electrical Power Requirements**

Transpector XPR 3+ must be connected to a source of power as specified in the following sections.

### **1.10.1 Required Supply Voltage**

20 to 30 V(dc), 24 V(dc) typical

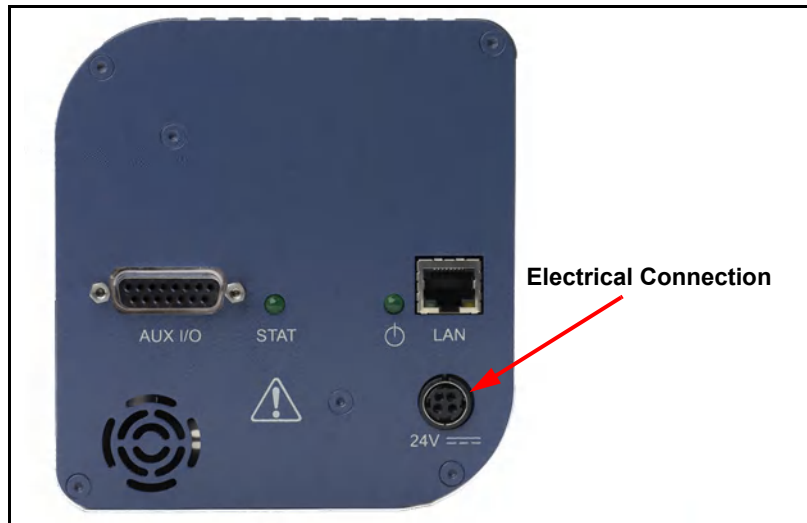
### **1.10.2 Current Rating**

1.25 A maximum

### **1.10.3 Electrical Connection**

Latching, 4-pin DIN connector, internally isolated from system ground.  
See [Figure 1-3](#).

Figure 1-3 Transpector XPR 3+ connections



## 1.11 Overvoltage Category

Overvoltage Category II (per EN61010-1)

## 1.12 Required Vacuum

Transpector XPR 3+:  $< 2.0 \times 10^{-2}$  Torr ( $2.66 \times 10^{-2}$  mbar) [2.66 Pascals]

## 1.13 Environmental Requirements

The following paragraphs explain the use, altitude range, humidity, pollution degree, and operating temperature for Transpector XPR 3+.

### 1.13.1 Use

Transpector XPR 3+ is designed for indoor use only.

### 1.13.2 Altitude Range

Transpector XPR 3+ can be used up to a maximum altitude range of 2000 m (6561 ft.).

### 1.13.3 Pollution Degree

Pollution Degree 2 (per EN61010-1)

### **1.13.4 Operating Temperature**

Transpector XPR 3+ is designed to operate within a temperature range of 5°C to 50°C (41°F to 122°F).

### **1.13.5 Humidity**

Transpector XPR 3+ is designed to operate in an environment with up to 98% relative humidity.

## **1.14 Computer System Requirements**

Refer to the FabGuard Explorer Operating Manual (PN 074-528-P1) for computer system requirements.

## **1.15 Software Installation**

Refer to the FabGuard Explorer Operating Manual (PN 074-528-P1) for information on installing the software and setting up the protocols necessary to ensure proper software operation.

## **1.16 Hardware Installation**

The following steps must be performed to install Transpector XPR 3+ Gas Analysis System.

- 1** If the optional Isolation Valve option was purchased with the Transpector XPR 3+ install the Isolation Valve, see [section 1.16.2 on page 1-11](#).
- 2** If the optional Pirani Gauge Interlock was purchased with the Transpector XPR 3+ mount the Pirani Interlock Weldment Assembly, see [section 1.16.3 on page 1-17](#).
- 3** If the optional Pirani Gauge Interlock was purchased with the Transpector XPR 3+ mount the Pirani Gauge, see [section 1.16.4 on page 1-18](#).
- 4** Install the Transpector XPR 3+ Sensor, see [section 1.16.5 on page 1-19](#).
- 5** Install the Transpector Electronics Module, see [section 1.16.6 on page 1-22](#).
- 6** Install the Communications cables, see [section 1.16.8 on page 1-23](#).
- 7** Install the 24 V DC Power Supply, see [section 1.16.9 on page 1-24](#).
- 8** If the optional Pirani Gauge Interlock was purchased with the Transpector XPR 3+ install the Transpector XPR 3+ Interlock Cable, see [section 1.16.10 on page 1-24](#).



- 9 If the optional Pirani Gauge Interlock and/or the optional Isolation Valve were purchased with the Transpector XPR 3+ attach the Heating Jackets, see [section 1.16.11 on page 1-25](#)
- 10 Install the Software.

### 1.16.1 Avoiding Process Metal Deposition



#### CAUTION

**Conductive deposits on the ceramic ion source plate from the process can cause electrical short circuits and a general failure of Transpector XPR 3+. The use of a 90° valve between the process and the sensor will alleviate this condition. The installation of a 90° valve is described in ConFlat Flanges.**

The sensor is installed on a vacuum system with a 2.75 in. DN40 ConFlat flange. ConFlat flanges, and similar compatible types made by other manufacturers, are used for attaching devices to ports on high vacuum systems. If there are no concerns with the installation of this type of flange, proceed to [section 1.16.5.1, Attaching the Sensor to the Vacuum Chamber, on page 1-19](#).

**NOTE:** If the system does not have a port with a compatible mating flange, an adapter will be necessary.

To install these flanges without leaks, follow proper operating procedures. These flanges are sealed with a metal gasket and can be heated for bakeout to temperatures of up to 200°C. For bakeout temperatures when a sensor is installed, see [Table 1-1 on page 1-21](#).

#### 1.16.1.1 Assembling ConFlat Flanges

To assemble a pair of ConFlat flanges:

- 1 Wipe the sealing areas of the flanges with a laboratory towel using a clean solvent, such as water free alcohol. These areas must be clean and free of particulate matter.

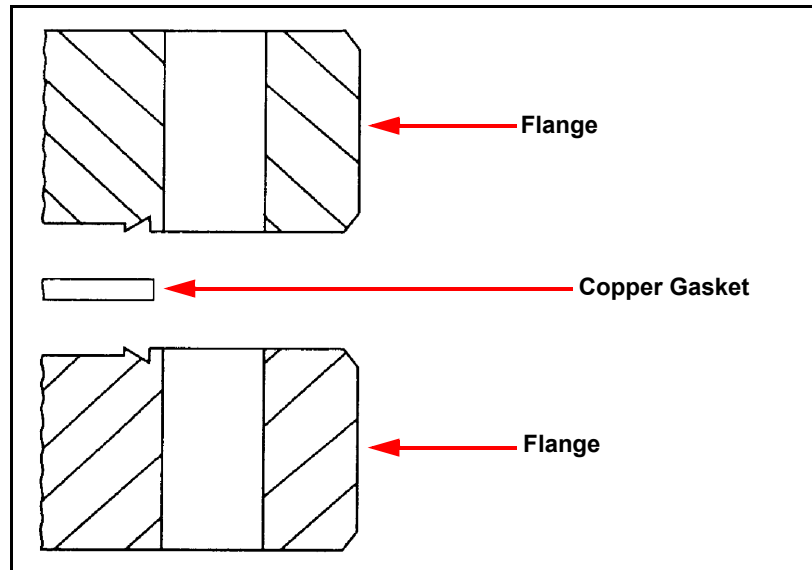


#### CAUTION

**Do not touch any surface on the gasket and flange faces with bare fingers. If it is necessary to touch any of these parts, always wear clean linen, nylon, powder free latex or vinyl laboratory gloves.**

- 2 Install the copper gasket between the two flanges. (See Figure 1-4.) Always use a new gasket. *Do not attempt to use gaskets more than once.*

Figure 1-4 Gasket and flange assembly



- 3 Bring the two flanges together making sure that the gasket fits in the recess in both flanges. Flange faces should be parallel. If the gasket is properly seated, it should not be possible to slide the two flanges laterally with respect to each other.
- 4 Install supplied silver-coated stainless steel bolts in the bolt holes of the flanges and finger-tighten.

**NOTE:** If the factory-supplied silver-coated stainless steel hardware is not used and the flanges are going to be baked, coat the bolt threads with an anti-seize compound (FelPro<sup>®</sup> C 100 or equivalent).



### CAUTION

**Do not get any of the anti-seize compound on the gaskets or vacuum parts of the flange.**

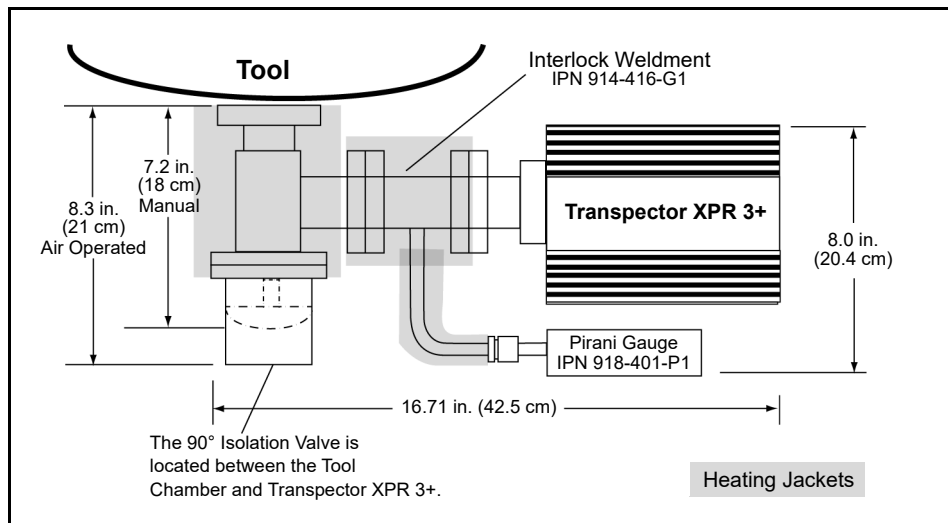
- 5 After the bolts have been finger-tightened and the flange faces are parallel, tighten the bolts gradually and evenly in a star pattern until the flange faces are brought into even contact with each other.

### 1.16.2 Installing the Isolation Valve

Transpector XPR 3+ should be installed on a 90° high-conductance isolation valve (1.5 in. [38 mm] outer diameter) mounted on the process chamber. This prevents line-of-sight deposits, from the plasma, from reaching the Transpector XPR 3+ Sensor. (See [Figure 1-5](#).) The isolation valve may be provided by the user, or purchased from INFICON (see below). The isolation valve must be bakeable and needs to be fitted with a heating jacket designed for baking the valve.

- ◆ 1½" Right Angle Valve Hand Operated with Heating Jacket:  
IPN 914-024-G1
- ◆ 1½" Right Angle Valve Air Operated with 24 V(dc) Solenoid and Heating Jacket: IPN 961-025-G1
- ◆ Valve Heating Jacket (150 °C; 120/230 V(ac) Operation):  
IPN 914-407-P1

Figure 1-5 Typical Connection of a Transpector XPR 3+ to the process chamber



#### 1.16.2.1 Notes for Air Operated Valve

The INFICON supplied air operated valve is a 1/8 in. ported, 3-way, single solenoid, 2-position spring return, Normally Open (NO) or Normally Closed (NC), general purpose air valve. It is configured for 2-way, NC use, whereby the EXH port is plugged and the air supply (60 - 100 psig) must be connected to the port labeled IN. (See [Figure 1-6](#).)



#### **WARNING**

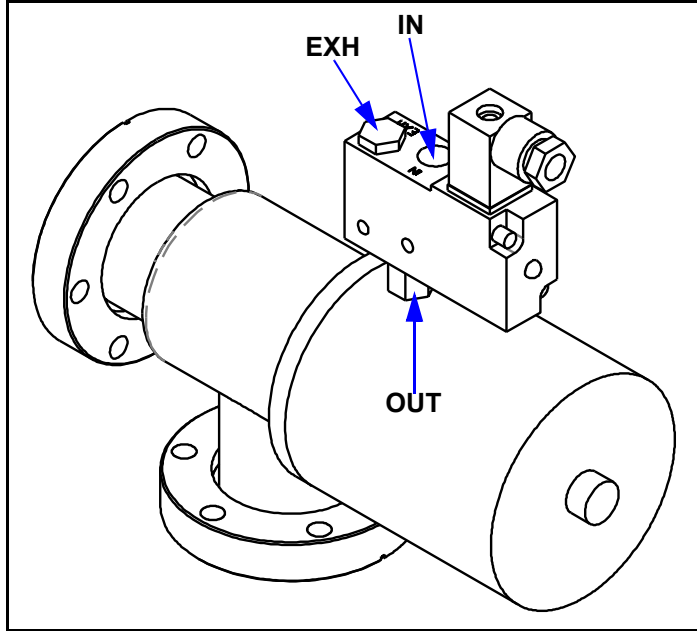
**The air pressure supplied to the valve must not exceed 100 psig.**



**CAUTION**

The air pressure supplied to the valve must be at least 60 psig.

Figure 1-6 INFICON supplied air valve

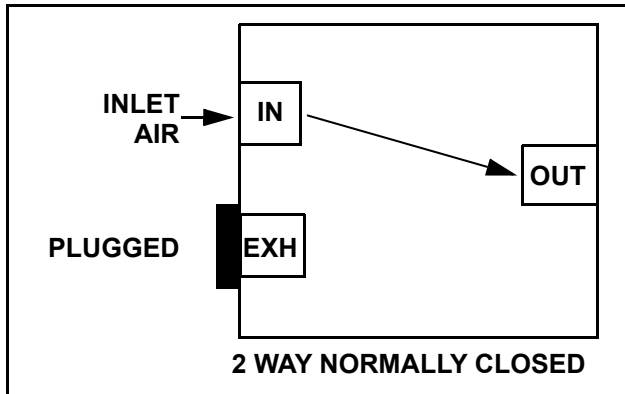


**1.16.2.2 Port Identification for 2-Way, Normally Closed Use**

See Figure 1-7.

- IN ..... Pressure supply port
- OUT ..... Delivery port to valve
- EXH ..... Exhaust port, plugged

Figure 1-7 Port identification



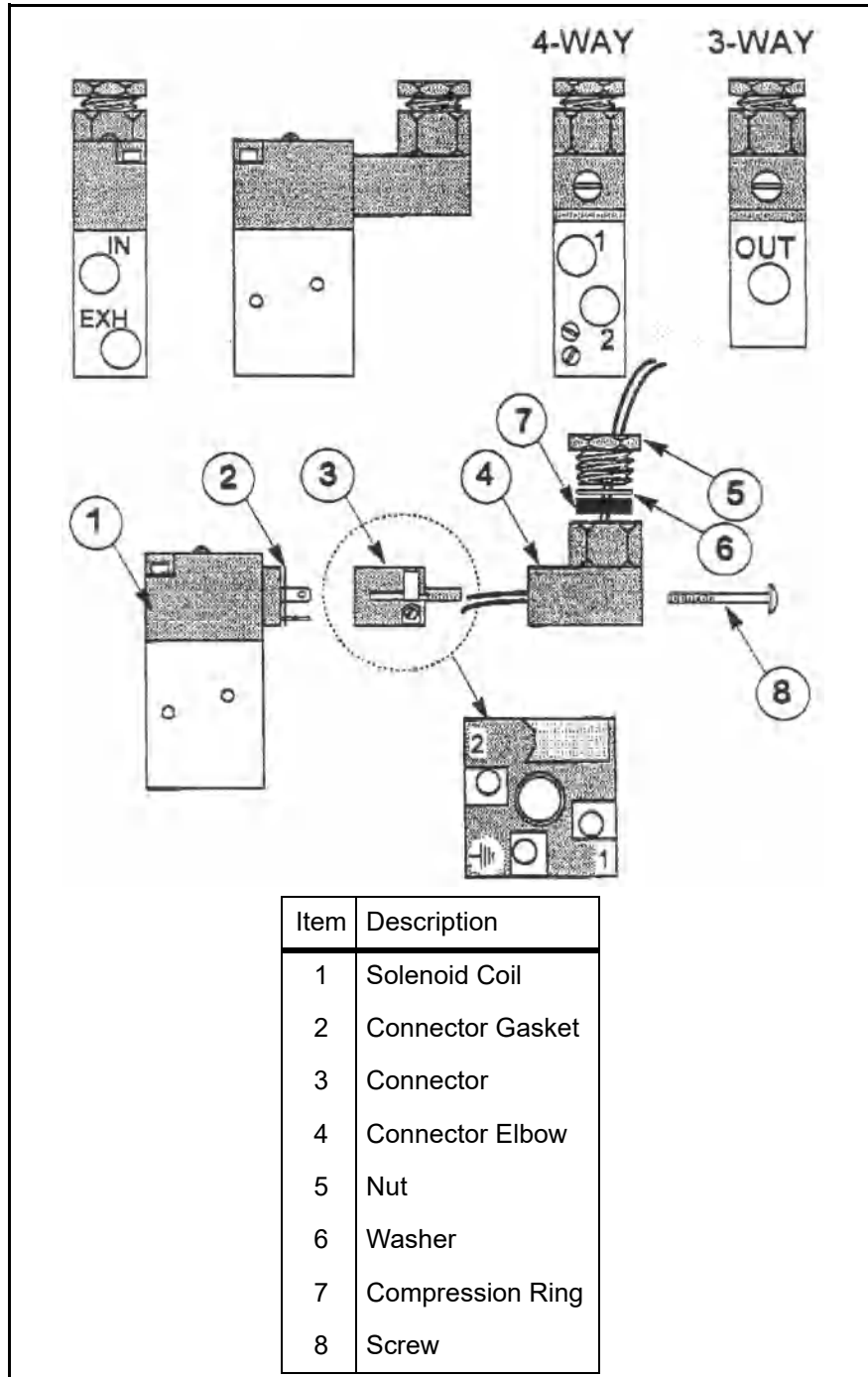
1.16.2.3 Valve Parts List



**WARNING**

This valve has an operational voltage rating of 24 V(dc) +10% to -15%.

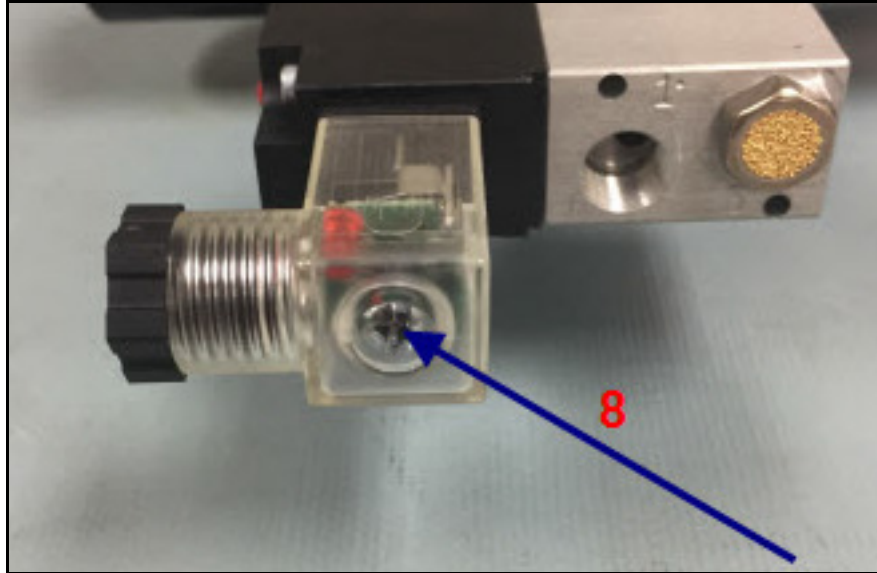
Figure 1-8 Valve parts list



### 1.16.2.4 Wiring Instructions

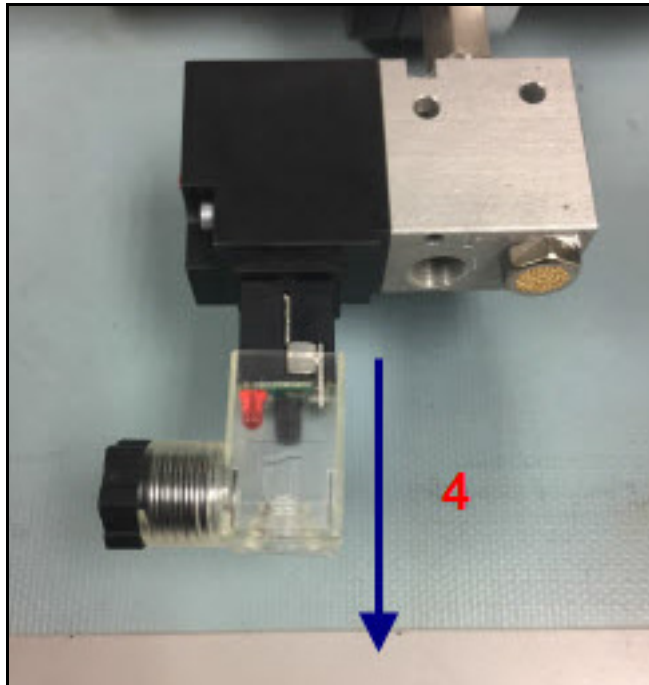
- 1 Remove the screw (8).

Figure 1-9 Removing connector assembly



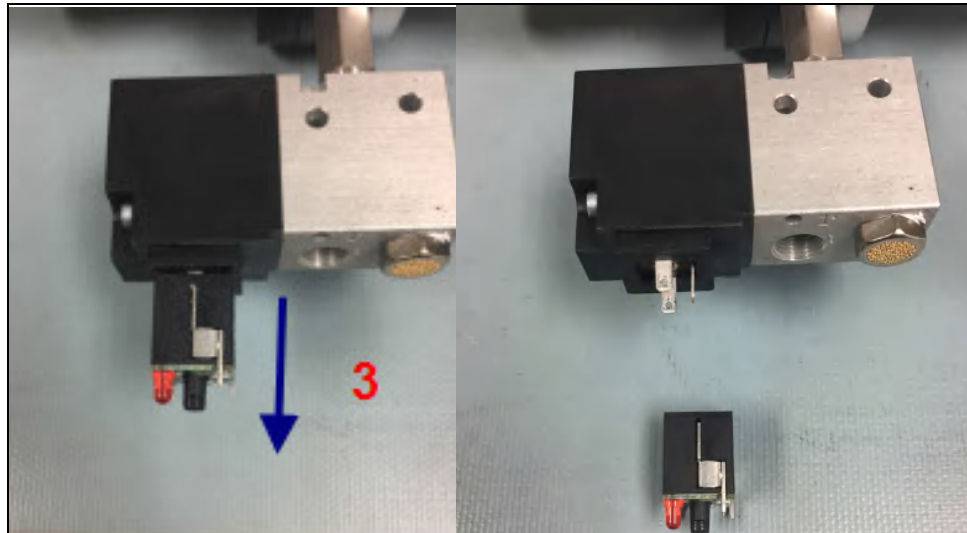
- 2 Remove the clear plastic connector elbow (4).

Figure 1-10 Removing connector elbow



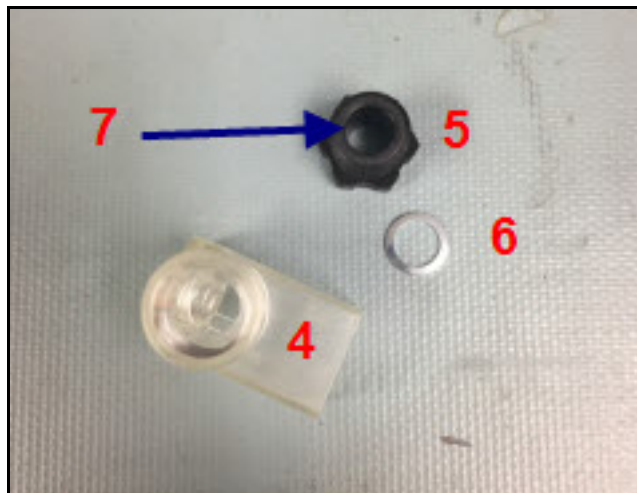
- 3 Remove the connector (3) from the solenoid assembly, be careful to not remove the connector gasket (2).

Figure 1-11 Removing connector terminal



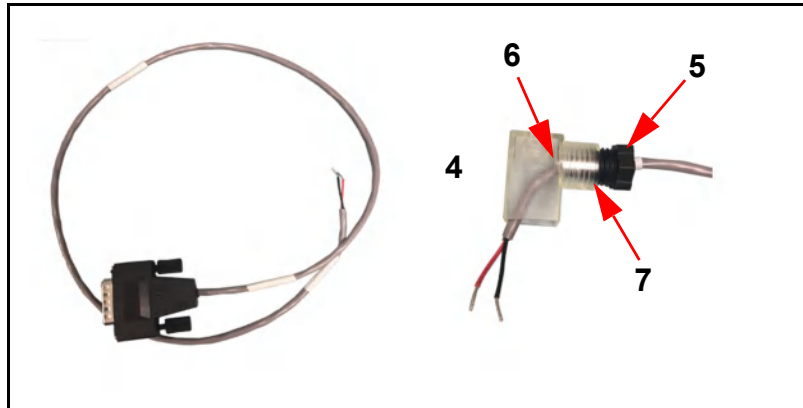
- 4** Remove the black plastic nut (5) from the connector elbow (4), the washer (6) and the compression ring (7) can stay in place.

Figure 1-12 Connect elbow assembly



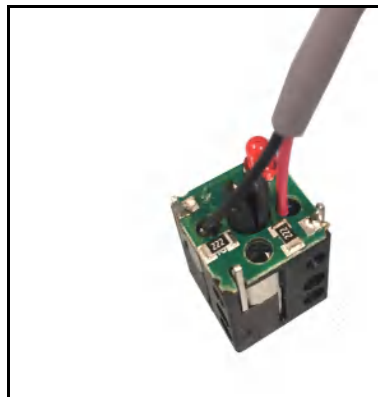
- 5** Take the MMSP Valve/Relay Interface Cable (IPN 600-1450-P2) and run the cables through the nut (5), washer (6), compression ring (7) and the connector elbow (4).

Figure 1-13 Cable and connector elbow feed



- 6 Connect the red and black wires to terminals 1 and 2 in either order. This can be done by soldering the wires in place or using the appropriate screw terminals on the connector (3) assembly.

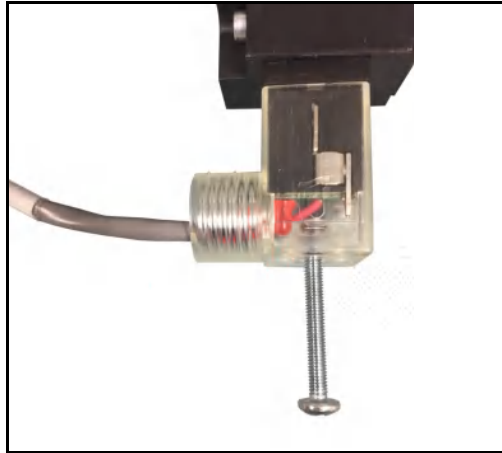
Figure 1-14 Connecting the red and black wires to the terminal



- 7 Press the connector (3) back into the connector elbow (4) screw the nut (5) securely into place. Connect the connector (3) to the solenoid coil (1) noting the connection scheme NOTE: When fitting the connector (3) into the connector elbow (4) note the orientation of the connection to the solenoid coil (1). Ideally the elbow should be facing away from the inlet air connection point as it can interfere with the connection of the inlet air.

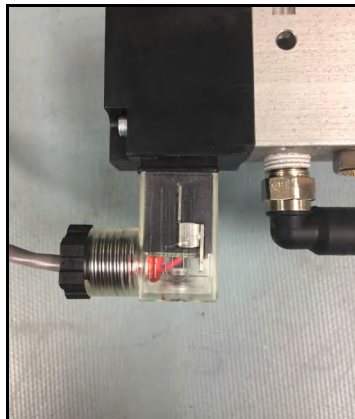


Figure 1-15 Connecting the connector



- 8 Screw the assembly back into the solenoid coil using the screw (8) removed in step 1.

Figure 1-16 Screw the assembly back into the solenoid coil



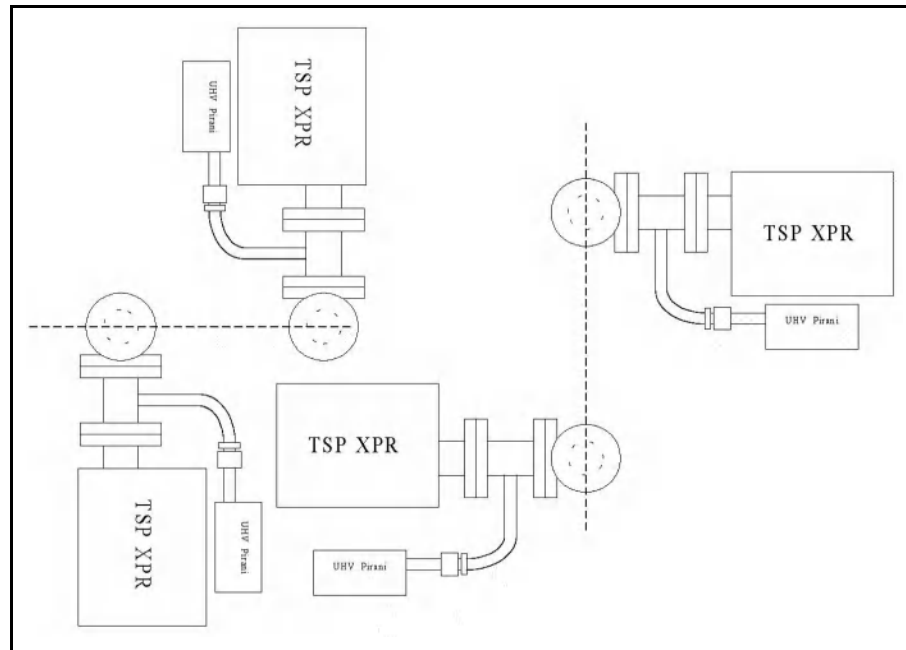
### 1.16.3 Mounting the Pirani Interlock Weldment Assembly

Transpector XPR 3+ Interlock Weldment Assembly with a Pirani gauge port has a 1.5 in. (38 mm) inner diameter for the Transpector XPR 3+ sensor. Both CF-40 flanges rotate to provide flexibility in orientation of the Pirani gauge with respect to the Transpector electronics module, the isolation valve, and the tool.

- 1 Evaluate, or pre-fit, Transpector XPR 3+ on the tool port to determine the orientation of the Transpector electronics module with respect to the tool, and the Pirani gauge with respect to a side of the Transpector electronics module. Typically, the Pirani gauge is placed under the Transpector electronics module if the axis of Transpector XPR 3+ is horizontal, as shown in [Figure 1-17](#).

**NOTE:** For measurements of  $2 \times 10^{-2}$  Torr or less, that are involved in protection of the Transpector XPR 3+ filament, the Pirani gauge retains its accuracy in any orientation.

Figure 1-17 Orientations for mounting an Transpector XPR 3+ on a tool



- 2 Attach the Interlock Weldment Assembly to the 1½ in. Right Angle Valve with a Cu gasket using ¼-28 x 1¼ in. 12 pt SS silver plated bolts, with the nut plates on the Valve side. Tighten the bolts finger tight.
- 3 Check for orientation and alignment: the Pirani gauge tube should be oriented so that the VCR fitting is facing away from the valve.
- 4 Tighten all the bolts evenly and gradually in a star pattern until the flange faces come into contact.

#### 1.16.4 Mounting the Pirani Gauge

The Pirani gauge is UHV compatible with a SS body, ceramic electrical feed-through and a 8-VCR female mounting flange.

- 1 Connect the Pirani gauge flange to the port on the Interlock Weldment Assembly using a Ni-8-VCR -2 silver plated Ni gasket.
- 2 Adjust the orientation of the Pirani gauge and tighten the gland finger tight. Use a 1-1/16 in. open end wrench for the female nut and a 15/16 in. open end for the male nut.

**NOTE:** For Ni gaskets, tighten an additional 1/8 turn (45 degrees) beyond finger tight with the wrenches to seal the Pirani gauge fitting. Rotation of the Pirani gauge can be inhibited by rotating the male nut and keeping the female nut wrench fixed.

### 1.16.5 Sensor Installation



#### CAUTION

---

**Do not touch any surface on the vacuum side of the sensor with bare fingers. If it is necessary to touch any of these parts, always wear clean linen, nylon, powder free latex or vinyl laboratory gloves.**

**Before installing the sensor on your system, check for any signs of loose or broken parts.**

**Do not attempt to clean the sensor in any kind of solvent. Cleaning the sensor requires its disassembly. If the sensor is contaminated and needs cleaning, contact INFICON.**

---

#### 1.16.5.1 Attaching the Sensor to the Vacuum Chamber

The sensor may be mounted in any position when attaching it to the vacuum vessel or chamber.

- 1** Attach the Transpector XPR 3+ Sensor Flange to the Pirani Interlock Weldment Assembly CF-40 Flange with a Cu gasket using  $\frac{1}{4}$ -28 x  $1\frac{1}{4}$  in. 12pt SS silver plated bolts, with the nut plates on the Transpector XPR 3+ side of the Flange. Tighten the bolts finger tight.
- 2** Tighten all the bolts evenly and gradually in a star pattern until the flange faces come into contact.

**CAUTION**

Avoid mounting the sensor near any magnetic fields greater than two gauss.

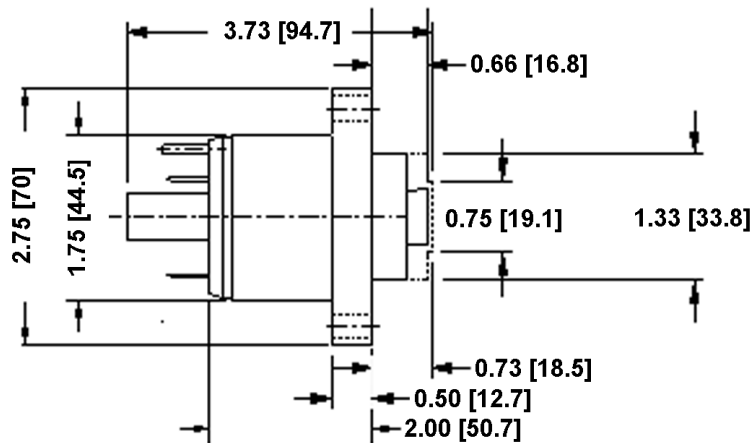
It is important that the connection between the sensor and the vacuum chamber does not interfere with gas exchange to ensure that the gas composition accurately reflects that existing in the vacuum chamber.

If materials are evaporated or coatings are deposited in the vacuum chamber, the sensor must be protected against the deposition of these materials on its surfaces by installing a baffle or deflector.

In systems which are baked, include the sensor in the bakeout zone or provide it with separate heaters.

Dimensions of the quadrupole sensors are shown in [Figure 1-18](#).

Figure 1-18 Sensor dimensions





**CAUTION**

The silver-plated bolts used for mounting the sensor to the vacuum system must be oriented such that the bolt heads are on the same side of the sensor as the electronics box. Otherwise, there may be interference between the black INFICON Transpector mounting nut and sensor mounting hardware.



**CAUTION**

Maximum bakeout temperature for sensors is shown in [Table 1-1](#).

Table 1-1 Sensor maximum bakeout temperature

Sensor	Maximum Operating Temperature	Maximum Bakeout Temperature Electronics Removed
Transpector XPR 3+	150°C	200°C



**CAUTION**

Transpector XPR 3+ electronics module must be removed prior to bakeout at temperatures greater than 150°C (FC).

Do not turn on the Electron Multiplier (EM) at sensor temperatures above 150°C. Turning on the EM at elevated temperature could result in permanent damage to the detector.



**WARNING**

During or immediately after bakeout, the heating jacket and metal surfaces in the vicinity of the heating jacket may be extremely hot. These surfaces may exceed 100°C at the maximum ambient operating temperature (50°C), which will cause burns if touched directly without using the proper personal protection equipment.

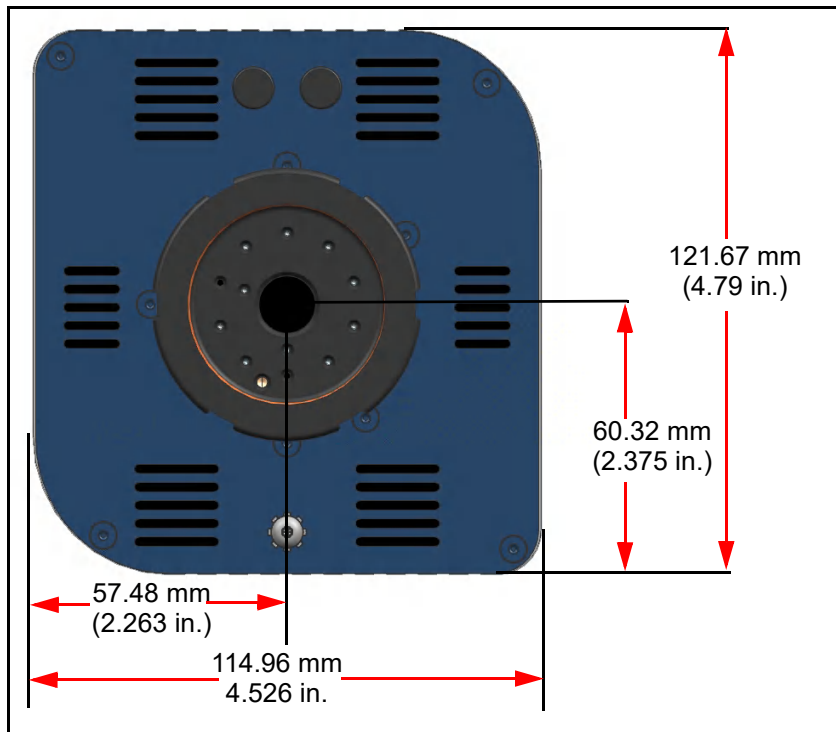
### 1.16.6 Electronics Module Installation

Transpector XPR 3+ electronics module must be mounted in an area where the ambient temperature does not exceed 50°C and there is free air circulation around the electronics module. Best performance will be achieved if the electronics module is not located close to major heat sources where it is subjected to wide temperature variations. (See [Figure 1-19](#).)

After the sensor has been installed on the vacuum system, the Transpector XPR 3+ electronics module must be mounted on the sensor:

- 1 The Transpector XPR 3+ sensor mounting connector assembly includes a mounting nut, a flat teflon ring, and an O-ring. When the mounting nut is tightened, the O-ring compresses making a tight fit on the sensor housing. For proper installation, place the nut over the end of the sensor and roll the O-ring back to the groove on the sensor.
- 2 Note the alignment pin or key pin and match the sensor feedthrough to the electronics module and carefully slide the Transpector XPR 3+ module onto the sensor. Ensure the Transpector XPR 3+ electronics module slides on fully.
- 3 Hand tighten the mounting nut on the Transpector XPR 3+ sensor.
- 4 Continue to [section 1.16.8](#) and install the communications cable.

Figure 1-19 Electronics module dimensions



### 1.16.7 Initial Start-up Procedure

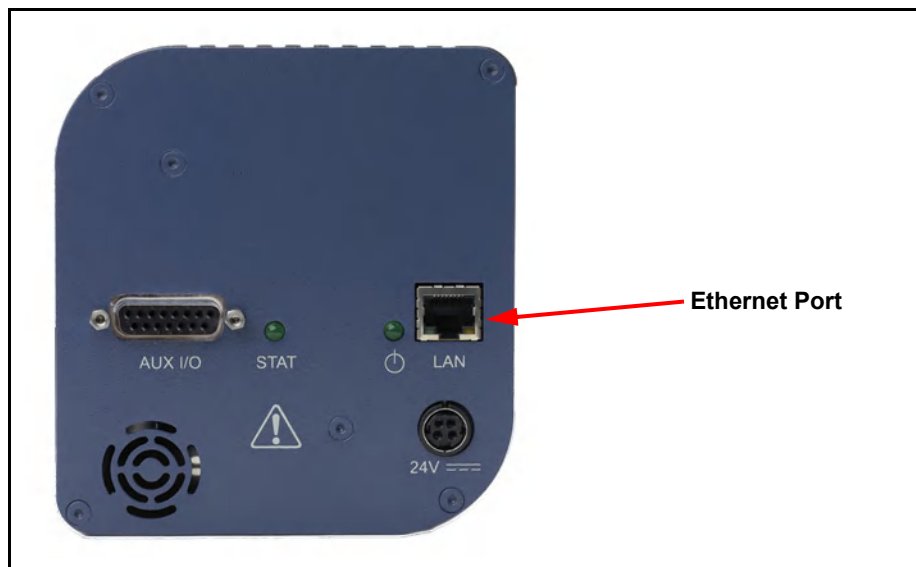
Once the Transpector XPR 3+ sensor, electronics, valve and Pirani are installed, the valve should be opened to allow Transpector XPR 3+ to obtain high vacuum. It is strongly recommended that Transpector XPR 3+ be kept under high vacuum conditions for at least eight hours before the filament is turned on. It is also strongly recommended that Transpector XPR 3+ be baked out with the supplied heating jacket (which operates at 150 °C), for a period of at least eight hours. This eight hour minimum bakeout reduces residual water vapor levels that may be higher due to local surface outgassing effects. These recommendations should be followed whenever the Transpector XPR 3+ sensor is exposed to atmosphere for long periods of time and will serve to increase sensor life.

### 1.16.8 Installing Ethernet Communications

Communication cables are required to connect Transpector XPR 3+ to the computer. Ethernet communication is the default communication method for Transpector XPR 3+. Communication cables are required to connect Ethernet communication uses standard RJ45, Cat5e Ethernet cables. To use Ethernet communications, attach the supplied Cat5e Ethernet cable to the LAN port on the back of the Transpector XPR 3+ electronics module. (See [Figure 1-20](#).)

For networking information, see [section 2.2](#).

Figure 1-20 Ethernet port



### 1.16.9 Connecting the 24 V(dc) Power Supply

- 1 Connect the +24 V (dc) power supply cable to the **24V** connector on the Transpector XPR 3+ electronics module by sliding back the latch, installing the cable, and then releasing the latch.

**NOTE:** The latch locks the connector to the electronics module, and must be slid back to detach the cable from the Transpector XPR 3+ electronics module.

- 2 Plug the AC line cord into the mating IEC320 connector on the power supply module.

**NOTE:** The AC Line Input for the +24 V(dc) Power Supply must be rated: 90-260 V(ac), 40 W maximum, 47-63 Hz.

- 3 Plug the AC line cord into an appropriate AC outlet.
- 4 Verify that the green power indicator on the Transpector XPR 3+ back panel is illuminated. If the green indicator is not illuminated, check the power connections.

### 1.16.10 Connecting the Pirani Interlock Cable

The Pirani gauge is fully powered by the Transpector XPR 3+ Auxilliary I/O connection. Install the RJ-45 connection of the interlock cable into the gauge and connect the 15-pin D-Sub connection to the Auxilliary I/O port of Transpector XPR 3+. See [Figure 1-21](#).

Figure 1-21 Assembled interlock





### 1.16.11 Attaching Heating Jackets

Heating Jackets for the Transpector XPR 3+ Pirani Interlock Weldment and the Isolation Valve are installed separately but share a common power cord.

The dual element heater can be operated with 120/230 V(ac) by choosing the power cord with the appropriate power source connector. Part numbers for the heaters and power cords are:

- ◆ Dual element heater for Interlock Weldment  
IPN 914-415-P1
- ◆ Dual element heater for Isolation Valve  
IPN 914-407-P1
- ◆ Power cord for 120 V(AC) operation  
IPN 600-1487-P1 and 068-0433
- ◆ Power cord for 230 V(AC) operation  
IPN 600-1487-P2 and 068-0434

The operating temperature of the heater is nominally 150 °C. Thermal over-temperature protection is built into the heater.



#### **WARNING**

**During or immediately after bakeout, the heating jacket and metal surfaces in the vicinity of the heating jacket may be hot. These surfaces may exceed 100 °C at the maximum ambient operating temperature (i.e., 50 °C), which will cause burns if touched directly without using the proper personal protection equipment.**

### 1.17 Input/Output (I/O)

This section describes the input and output (I/O) for Transpector XPR 3+.

The Transpector XPR 3+ electronics module supports the following I/O functions through the AUX I/O connector located on the back panel. See [Figure 1-22](#).

### 1.17.1 Two Digital Inputs

Logic Inputs 1 and 2 are by default set to remotely control emission status. Connecting Pin 14 (Logic Input 1) to Pin 15 (Ground) will turn on the emission. Connecting Pin 13 (Logic Input 2) to Pin 15 will turn off the emission. See [Table 1-2](#).

Table 1-2 Digital inputs

Emission ON	PIN 14
Emission OFF	PIN 13
GND	PIN 15



#### CAUTION

Controlling emission through the digital inputs bypasses all software or hardware interlocks. When using digital inputs for controlling Transpector XPR 3+ emission, develop an interlock that will not allow the emission to turn on if the pressure is too high for operation of Transpector XPR 3+.

### 1.17.2 One Status Relay Output

One status relay output is active (closed) when the emission is on. See [Table 1-3](#).

Table 1-3 Status relay output

EMISSION ON	Relay closed. PIN 2 and PIN 1 connected
EMISSION OFF	Relay open
CONTACT RATING	24 V(dc) at 0.5 A

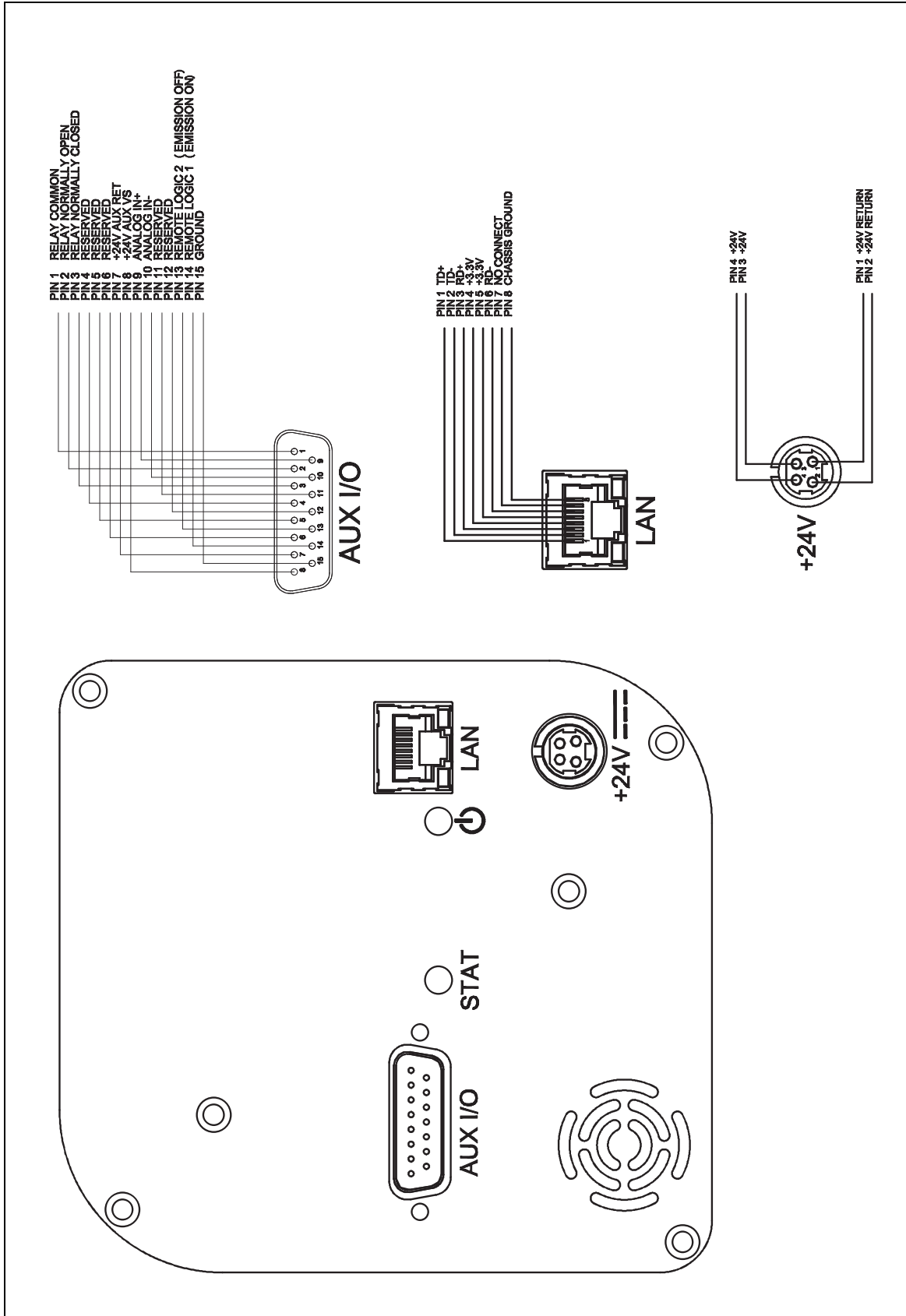


Figure 1-22 Pinout connectors

### 1.17.3 One Analog Input

One analog input is differential and can handle inputs between 0 to +10 volts and common mode voltages of 100 volts. See [Table 1-4](#).

*Table 1-4 Analog inputs*

ANALOG INPUT 1	(+)	PIN 9
ANALOG INPUT 1	(-)	PIN 10

**NOTE:** The analog input is supported through FabGuard software. If the Pirani interlock option is configured the Pirani gauge reading will use analog input 1.

---

## Chapter 2

# Connecting Transpector XPR 3+

---

### 2.1 Introduction

Transpector XPR 3+ uses Ethernet as its default communications method.

Transpector XPR 3+ has an IP address and a MAC address.

IP addresses are used as a means of identifying individual devices on a network. IP addresses are unique on a network but not universally, that is, meaning that only one device on a network can have a specific IP address but two devices on separate networks can have the same IP address.

MAC addresses are another identifier that are unique for each device. MAC addresses are never duplicated. FabGuard uses IP addresses to locate and identify sensors on a network.

### 2.2 General Networking Information

This section will discuss some of the general networking variables that can affect the connection of Transpector XPR 3+.

#### 2.2.1 IP Addresses

IP addresses can be set either manually or automatically:

- ♦ Static (manual) IP addresses are set by the user and are manually changeable by the user
- ♦ Dynamic (automatic) IP addresses are automatically set by a Host

INFICON recommends using Static IP addresses for Transpector XPR 3+ but allows for Dynamic IP addresses set through DHCP (Dynamic Host Communication Protocol).

**NOTE:** When using Static IP addresses, a block of addresses should be reserved for Static use and prohibited from being assigned by the DHCP server (Host). This will avoid duplicate IP address conflicts from occurring.

**CAUTION**

---

**Since FabGuard uses the IP address to identify each connected Transpector XPR 3+, the IP address must not change during operation of Transpector XPR 3+.**

**Using DHCP, the host may generate a new IP address every time Transpector XPR 3+ is taken offline and then returns online.**

**DHCP may also change the IP address automatically if there is an IP address conflict on the network.**

**If the Transpector XPR 3+ IP address is randomly changed during data acquisition, FabGuard will not automatically reconnect to the Transpector XPR 3+ sensor because it does not know the newly assigned IP address. This will lead to loss of communication and loss of data.**

**Static IP addresses do not change unless the IP address is manually changed. Static IP addresses help protect Transpector XPR 3+ from losing communication and data.**

---

Transpector XPR 3+ uses IPv4 IP addresses. IPv4 IP addresses consist of 32 bits that are traditionally displayed in dot-decimal notation which consists of four decimal numbers each ranging from 0 to 255 separated by dots. An example of an IP address in dot-decimal notation would be 192.168.1.100. Each part represents an octet. Normally, the IP address consists of a Network Prefix and a Host Protocol.

## 2.2.2 Subnetworking

A subnetwork (or subnet) is a logically visible subdivision of an IP (Internet Protocol) network. Splitting an IP network into multiple subnets is referred to as subnetting. Subnetting sets the region of the IP address that will be used as a Network Prefix for all IP addresses inside of a subnet. This is accomplished through a subnet mask. Different types of subnet masks and their implications to IP addresses are shown in [Table 2-1](#).

Table 2-1 Subnetting

	Example 1	Example 2	Example 3
<b>IP address</b>	192.168.1.104	192.168.1.105	192.168.1.150
<b>Subnet mask</b>	255.255.255.0	255.255.0.0	255.255.255.192
<b>Network prefix</b>	192.168.1.0	192.168.0.0	192.168.1.128
<b>Host Protocol</b>	0.0.0.104	0.0.1.105	0.0.0.22

As seen in [Table 2-1](#), the subnet masks determine which octets of the IP address are used as the network prefix.

In order for two network devices to communicate, they must be on the same subnet. This means that they must not only be connected to the same internet network, but must also have the same network prefix. If two devices have two different network prefixes, this means that the two devices are on different subnets.

## 2.3 Transpector XPR 3+ IP Address

By default, Transpector XPR 3+ ships with an IP address of 192.168.1.100 with a subnet mask of 255.255.0.0.

**NOTE:** When connecting Transpector XPR 3+ to an existing local network, there must be a static IP address for each Transpector XPR 3+ being installed. Contact the network administrator for IP address assignments.

### 2.3.1 Changing Transpector XPR 3+ IP Address

There are two different methods of changing the Transpector XPR 3+ IP address.

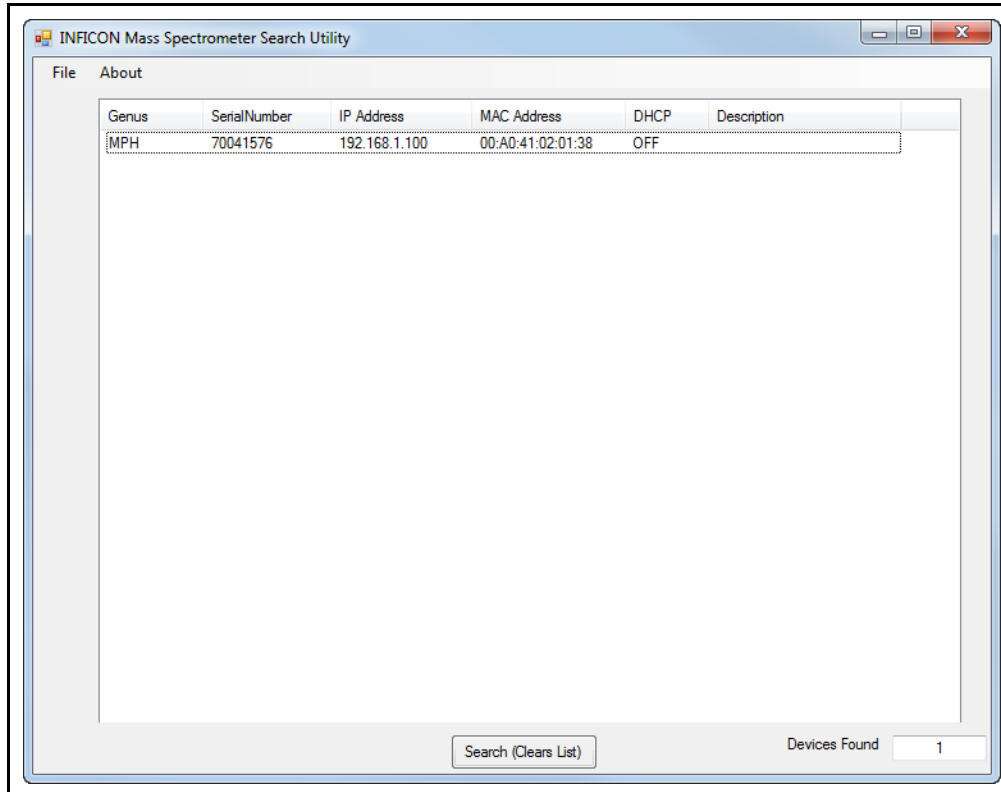
The first method utilizes the onboard Transpector Web UI to change the IP address. Instructions for changing the IP address via Transpector Web UI can be found in [section 2.3.1.1.1 on page 2-5](#).

Alternatively, the IP address can be changed through a standalone executable as discussed next in [section 2.3.1.1 on page 2-4](#).

### 2.3.1.1 Using the INFICON Mass Spectrometer Search Utility to Change the IP Address

The alternative method of changing the Transpector XPR 3+ IP address employs the INFICON Mass Spectrometer Search Utility (IMSSU), a standalone executable found on the software installation disk and the RGA Manuals CD that ships with each Transpector XPR 3+. To use the IMSSU, locate and double-click **INFICONMassSpecSearch.exe**. The program does not need to be installed to work. Upon double-clicking, the IMSSU will display as shown in [Figure 2-1](#).

Figure 2-1 INFICON Mass Spectrometer Search Utility



When the IMSSU first opens, nothing will be displayed. The IMSSU detects all Transpector XPR 3+ installed on the network regardless of IP address. The IMSSU will start automatically, or it can be manually started by clicking **Search (Clears List)**. The IMSSU will then display the:

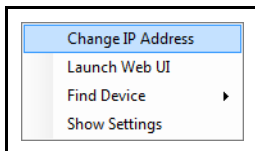
- ◆ Genus (which will display XPR 3+ for Transpector XPR 3+ sensors)
- ◆ Transpector XPR 3+ Serial Number
- ◆ Current IP address of Transpector XPR 3+
- ◆ MAC address of Transpector XPR 3+
- ◆ DHCP status of Transpector XPR 3+ (On or Off)
- ◆ Description (which is user editable)



### 2.3.1.1.1 IMSSU Capabilities

The IMSSU has multiple built-in functions. All of these functions are available by right-clicking on the sensor inside of the IMSSU. The right-click menu can be seen in [Figure 2-2](#), and the different functions are described in the following sections.

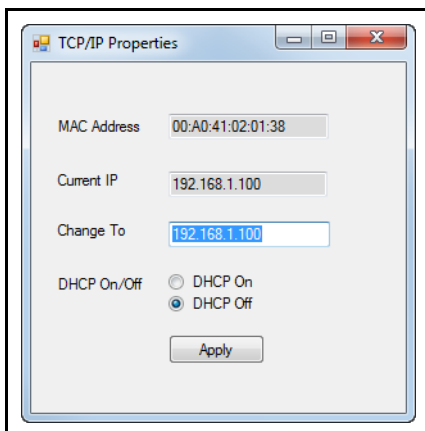
Figure 2-2 IMSSU right-click menu



#### **Changing Transpector XPR 3+ IP Address**

To change the IP address, right-click on the sensor and select **Change IP Address**. The **TCP/IP Properties** window will display, see [Figure 2-3](#).

Figure 2-3 IMSSU TCP/IP Properties window



The **TCP/IP Properties** window will display:

- ◆ Transpector XPR 3+ MAC Address
- ◆ the current Transpector XPR 3+ IP address
- ◆ a **Change To** text box, to enter the new Transpector XPR 3+ IP address
- ◆ a selection of either **DHCP On** or **DHCP Off**

To change the IP address, type the new IP address in the **Change To** box and click **Apply**. Transpector XPR 3+ will automatically reboot and will return online with the new IP address.

Alternatively, the IP address can be automatically assigned to Transpector XPR 3+ by selecting **DHCP On** (*this is not recommended*).

#### **Launching Transpector Web UI**

Transpector Web UI can be launched from inside of the IMSSU.

**Find Device**

**Find Device On** will flash the power LED so that the device can be located. The LED will flash for up to 60 seconds and then return to the fully On state.

**Find Device Off** will stop the flashing if executed within 60 seconds of turning the **Find Device On**.

**Show Settings**

Click **Show Settings** to open a display on the right-side of the IMSSU that will display multiple settings of Transpector XPR 3+. This is an excellent tool for troubleshooting. The following settings are displayed:

- ◆ Serial Number
- ◆ Gateway
- ◆ IP Address
- ◆ DHCP Status
- ◆ MAC Address
- ◆ Description
- ◆ Subnet Mask
- ◆ Name
- ◆ Description
- ◆ Structure Version
- ◆ Name
- ◆ Box Type
- ◆ Port
- ◆ Firmware Version
- ◆ TCP/IP Source

### 2.3.1.2 Changing the Computer IP Address

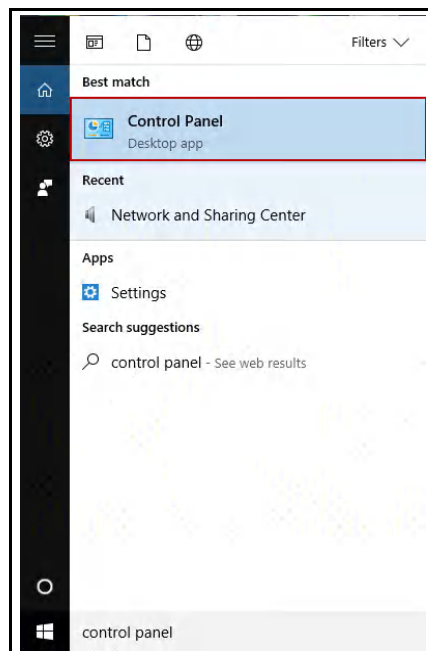
An alternative to changing the Transpector XPR 3+ IP address is to change the host computer's IP address to allow for communication between the host computer and Transpector XPR 3+. To change the computer's IP address, follow these instructions:

#### 2.3.1.2.1 Windows 7 Instructions

**NOTE:** Changing the IP address of the host computer requires administrator rights. You will need to use an administrator account to change the IP address.

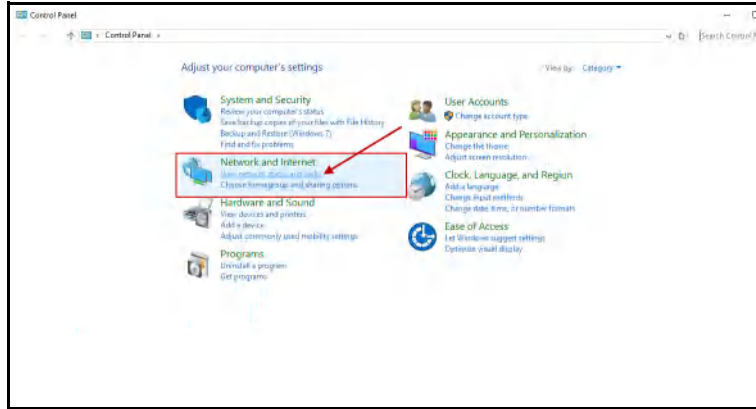
- 1 Click **Start** to display the **Start** menu, then click **Control Panel**. **Start** is located on the taskbar on the Windows 7 desktop. See [Figure 2-4](#).

Figure 2-4 Start menu



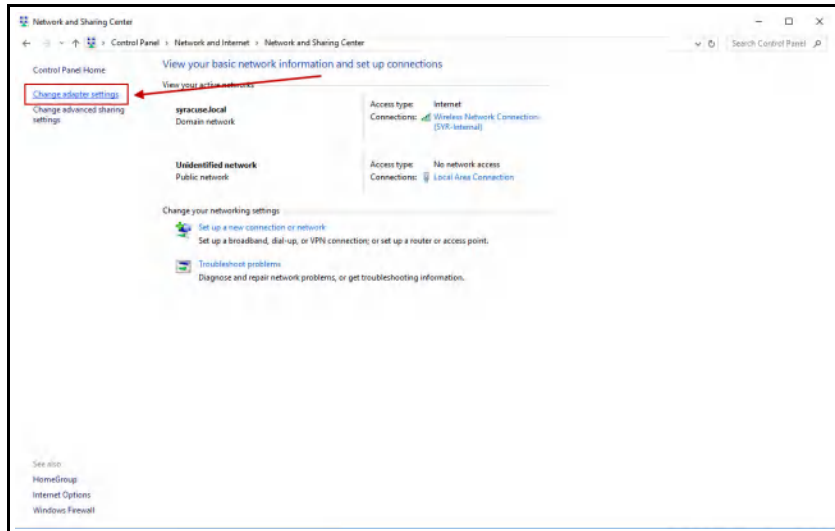
- In the **Network and Internet** group, click **View network status and tasks**. See [Figure 2-5](#).

Figure 2-5 View network status and tasks



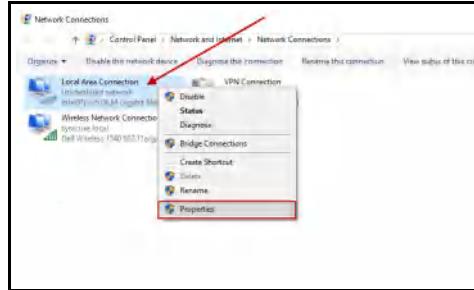
- On the network status and tasks window, click **Change adapter settings**. See [Figure 2-6](#).

Figure 2-6 Change adapter settings



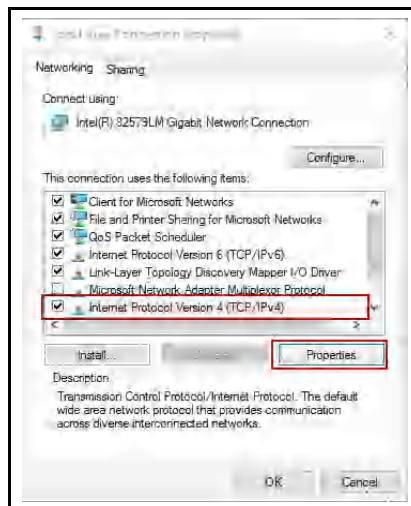
- 4 If the host computer is connected to Transpector XPR 3+ through the Ethernet port of the computer, right-click **Local Area Connection** and select **Properties**. See Figure 2-7.

Figure 2-7 Changing adapter settings



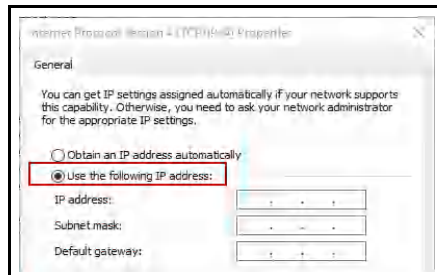
- 5 Select **Internet Protocol Version 4 (TCP/IPv4)**, then click **Properties**. See Figure 2-8.

Figure 2-8 TCP/IPv4



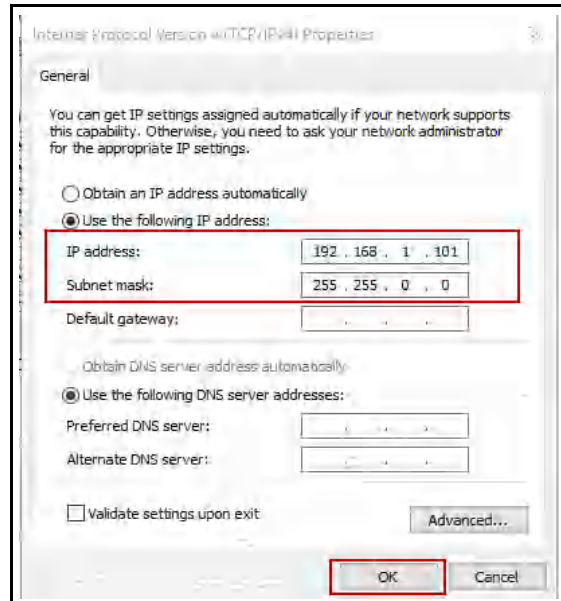
- 6 In the TCP/IPv4 properties menu, select **Use the following IP address**. See Figure 2-9.

Figure 2-9 Use the following IP address



- 7 In **IP address**: type **192.168.1.XXX**. The last octet can be any number as long as it is unique to the network. See [Figure 2-10](#).
- 8 In **Subnet mask**: type **255.255.0.0**.
- 9 Click **OK**.

Figure 2-10 Changing the computer IP address



- 10 The IP address will now be set to the manual IP address chosen in step 7. Exit all of the menus and then connect to Transpector XPR 3+.
- 11 To change the IP address back to its default settings, follow steps 1 through 6 and return the IPv4 properties to their original settings.

## 2.4 Connecting Transpector XPR 3+

Before connecting Transpector XPR 3+, decide:

- 1 Is Transpector XPR 3+ going to be set up on:
  - ♦ a private network (installed directly on to either a computer or a router that is not hooked up to the internet), or
  - ♦ an internal network where multiple computers are connected with access to the internet?
- 2 Is more than one Transpector XPR 3+ sensor being installed at the same time?

## 2.4.1 Connecting a Single Transpector XPR 3+

### 2.4.1.1 Single Transpector XPR 3+ Direct Connection Installation

When installing a single Transpector XPR 3+ on a private network or directly connected to a computer, changing the IP address of Transpector XPR 3+ is only necessary if the computer being used to connect to Transpector XPR 3+ has a different network prefix than Transpector XPR 3+.

The network prefix of Transpector XPR 3+ is **192.168.x.x**. The IP address of the host computer used to control Transpector XPR 3+ must have a subnet mask of **255.255.0.0** and a network prefix of **192.168.x.x**.

If this is not the case, change the computer IP address to match the network prefix of Transpector XPR 3+. For example, giving the computer an IP address of **192.168.1.101** will allow Transpector XPR 3+ to communicate directly with the computer. Refer to [section 2.3.1.2, Changing the Computer IP Address, on page 2-7](#).

### 2.4.1.2 Installing a Single Transpector XPR 3+ on an Existing Local Network

When installing a single Transpector XPR 3+ on an existing local network, the default IP address of Transpector XPR 3+ may not be compatible with the network.

Transpector XPR 3+ can have either a Static IP address (*recommended*) or a Dynamic IP address set by DHCP (*not recommended*).

Contact your network administrator for information regarding valid IP addresses and have them assign an IP address for Transpector XPR 3+. See [section 2.3.1, Changing Transpector XPR 3+ IP Address, on page 2-3](#).

## 2.4.2 Installing Multiple Transpector XPR 3+ Sensors

Since each Transpector XPR 3+ is shipped with the same default IP address, the IP address of each Transpector XPR 3+ must be changed one at a time so that each sensor has a unique IP address. See [section 2.3.1, Changing Transpector XPR 3+ IP Address, on page 2-3](#).



### CAUTION

---

**Do not connect multiple Transpector XPR 3+ to a network at the same time without first changing the IP addresses. Since the IP addresses are not unique, connecting multiple units at the same time will cause IP address conflicts on the network.**

---

#### **2.4.2.1 Installing Multiple Transpector XPR 3+ Directly to a Host Computer**

If multiple Transpector XPR 3+ sensors are to be connected to a single host computer and not to an existing local area network, a private local network must be created. Transpector XPR 3+ will have to be installed on either a router or Ethernet switch. The router or switch is then connected to the host computer through the LAN port of the router/switch.

#### **2.4.2.2 Installing Multiple Transpector XPR 3+ on an Existing Local Network**

If multiple Transpector XPR 3+ sensors are to be connected to an existing local network, use an Ethernet switch instead of a router.

**NOTE:** Routers can cause conflicts with local networks because the router will attempt to set IP addresses for all network connected devices.

Since Transpector XPR 3+ sensors will be network connected devices, each sensor must have an IP address assigned to it by a network administrator. After changing each IP address manually, connect all of the sensors to the Ethernet switch and connect the switch to the local network.



---

## Chapter 3

### How The Instrument Works

---

#### 3.1 Introduction

This section explains how Transpector XPR 3+ produces its measurements.

#### 3.2 Overview

Transpector XPR 3+ Gas Analysis System is a miniature quadrupole partial pressure analyzer which measures the partial pressures of gases in a mixture. It is controlled by an external computer. Transpector XPR 3+ Gas Analysis System consists of these parts: a sensor that functions only in a high-vacuum environment, an electronics module which operates the sensor, and the software which resides on an external computer and controls the electronics module.

**NOTE:** The high-vacuum environment means pressures below 2.6 Pascals, or approximately  $2 \times 10^{-2}$  Torr [approx.  $2.6 \times 10^{-2}$  mbar].

#### 3.3 Patents

The following patents are applicable to the design and operation of Transpector XPR 3+ system.

**"Method of manufacturing a miniature quadrupole using electrode-discharge machining" [US 5,852,270]**

Abstract

A method for manufacturing a miniature quadrupole from a single blank includes fastening four lengthwise insulating strips into parallel slots formed in the blank. A lengthwise axial hole is cut through the blank for the guide wire used in the EDM process. The blank is machined lengthwise into four electrodes using the EDM process so that the electrodes are spaced apart in a width-wise direction and each electrode is connected to an adjacent electrode by one of the insulating strips. During the cutting, the electrodes are held in place by the insulating strips.

**"Method for linearization of ion currents in a quadrupole mass analyzer"  
[US 5,889,281]**Abstract

A method of linearizing the sensitivity of a quadrupole mass spectrometric system to allow the sensor to more accurately report partial pressures of a gas in high pressure areas in which the reported data is effected by a number of loss mechanisms. According to the invention, correction factors can be applied empirically or software in a quadrupole mass analyzer system can be equipped with correcting software to expand the useful range of the mass spectrometer.

**"Ion collector assembly" [US 6,091,068]**Abstract

An ion collector includes a Faraday Cup collector having a conductive surface disposed substantially parallel to and spaced from the axis of an entering particle beam containing charged and uncharged particles. A grounded plate disposed in the path of the particle beam allows incoming uncharged particles to impinge thereupon. Preferably, the application of a suitable potential to the conductive plate manipulates incoming charged ions to impinge upon either the electron multiplier or the Faraday collector. The ion collector can further include an electron multiplier used in conjunction with the Faraday collector to allow separate modes of operations. Application of a suitable first potential to the electron multiplier can cause charged particles to be deflected directly to the Faraday collector in one mode, and application of a second potential can cause deflection of charged particles to the electron multiplier, with the effects of the uncharged particles on the output of the detector being minimized.

**"Apparatus of measuring total pressure and partial pressure with common electron beam" [US Patent Application 20020153820]**Abstract

An apparatus for determining both total and partial pressures of a gas using one common electron beam includes a partial pressure ionization region and a total pressure ionization region separated by a grid or aperture. A filament produces a plurality of electrons which are focused into an electron beam by a repeller and an aperture or an anode. The interactions between the electron beam and molecules of said gas within the partial pressure and total pressure regions produces first and second ion streams. A focus plate is biased such that the first ion stream is directed to an analyzer which calculates the partial pressure of the gas. An ion collector collects the ions from the second ion stream, where the resulting reference current is used to determine the total pressure of the gas.

### 3.4 Sensor

The Transpector XPR 3+ sensor (see [Figure 3-2](#)) analyzes gases by ionizing some of the gas molecules (in the ion source), separating the ions by mass (in the mass filter), and measuring the quantity of ions at each mass (in the detector). The masses, unique for each substance, identify the gas molecules from which the ions were created. The magnitudes of these signals are used to determine the partial pressures (amounts) of the respective gases.

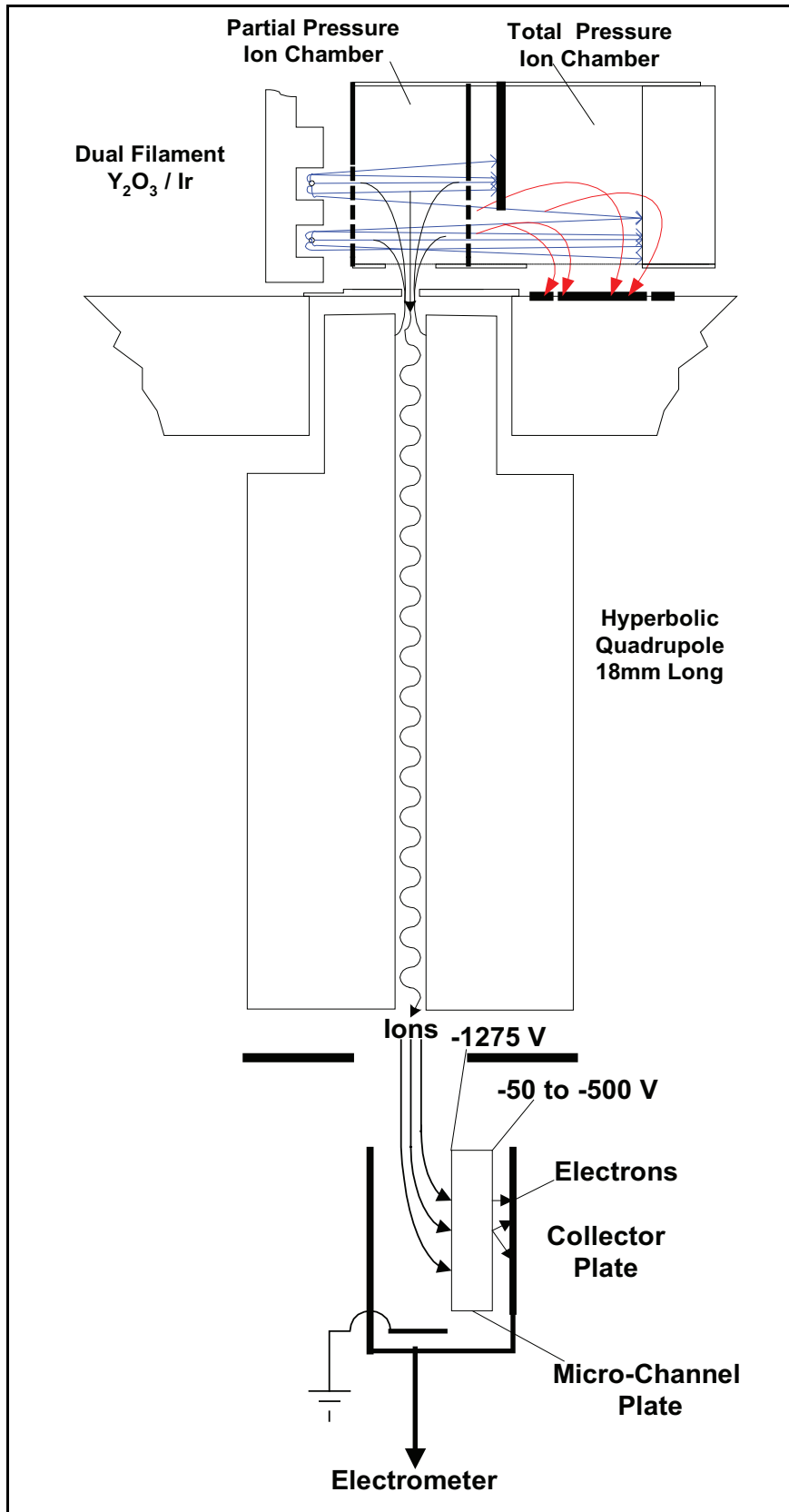
The Sensor consists of three main parts:

- ◆ ion source (ionizer)
- ◆ quadrupole mass filter
- ◆ ion detector

All of these parts are mounted on an electrical feed-through flange, which is bolted to the vacuum chamber where the gas analysis measurements are made.

The sensor works only in a high-vacuum environment because the ions, once created, must not collide with other gas molecules as they move through the sensor; otherwise, they might not be detected. The miniature design of Transpector XPR 3+ allows it to operate at pressures higher than those necessary for traditional RGA sensors.

Figure 3-1 Transpector XPR 3+ sensor



### 3.4.1 The Ion Source

The Transpector XPR 3+ sensor's ion source, optimized for detecting residual gases in a vacuum system, has a fairly open construction that facilitates the flow of gas molecules into the ionizing region.

The ion source of Transpector XPR 3+ operates on the same principles as the larger ion sources of standard open ion source sensors. However, Transpector XPR 3+ is built with a dual ion source which supplies one ion stream to the quadrupole filter and a second ion stream to a total pressure collector. This design allows the total pressure collector to be well isolated from other electrodes in the ion source so that the small ion currents from the Transpector XPR 3+ source can be measured accurately.

Inside the ion source, a heated filament emits electrons, which bombard the gas molecules, giving them an electrical charge. While this charge may be either positive or negative, Transpector XPR 3+ detects only positive ions. Once a molecule is charged, or ionized, electric fields can be used to manipulate it.

The filament is an iridium wire with yttrium-oxide coating. The Transpector XPR 3+ filament can be protected by the Pirani Interlock, which controls emission within safe operating parameters.

The term "emission current" refers to the stream of electrons emitted by the filament. The filament is heated with a DC current from the emission regulator circuit, with the resulting temperature of the filament used as the means of controlling the emission current.

The potential (voltage) on the anode is positive with respect to the potential on the filament. The potential difference between the filament and the anode determines the kinetic energy (usually called the electron energy) of the emitted electrons. The electron energy in turn determines how gas molecules will ionize when struck by the electrons.

A three-sided repeller is centered around the filament and is connected to the low voltage side of the filament. This geometry and potential focuses the electrons through the partial pressure region and on into the total pressure ion region as shown in [Figure 3-2](#). The ions formed within the cage on the anode are pulled away by the potential on the focus lens and formed into a beam. (The focus lens is sometimes called an extractor, since it extracts the ions from the region in which they are created.) The focus lens also serves to focus the ion beam into the quadrupole. To attract positive ions, the focus lens is biased negatively with respect to the anode.

The ion beam generated in the partial pressure chamber passes through the hole in the focus lens and is injected into the mass filter. The ion beam generated in the total pressure chamber strikes the exit lens and is neutralized, resulting in a current flow. The magnitude of this current is related to the pressure in the ion source, and

can therefore, be used as a measure of the total pressure. When this current exceeds a preset level, the voltages operating the sensor are turned off, thus helping to protect the sensor from damage due to an over-pressure condition.



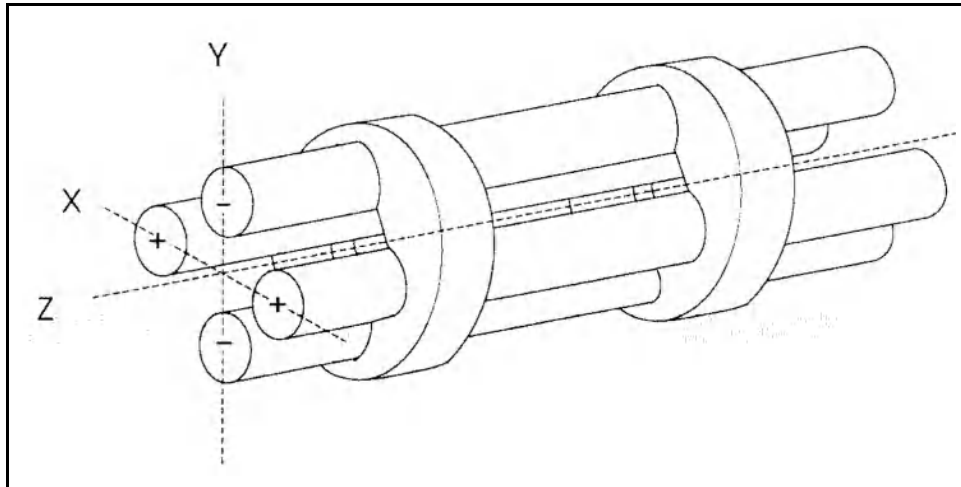
### CAUTION

**Although this over-pressure protection feature using the internally measured total pressure is available in Transpector XPR 3+, it is recommended to use only the Pirani Interlock for controlling emission to the sensor. Exposing the Transpector XPR 3+ sensor to over-pressure or trying to turn the emission on at high pressures exceeding the Transpector XPR 3+ operating specifications will cause the filaments to prematurely fail.**

### 3.4.2 The Quadrupole Mass Filter

The ions produced in the ion source are injected into the mass filter, which rejects all ions except those of a specific mass-to-charge ratio. Most ions contain only one unit of charge. In Transpector XPR 3+, the mass filter is a quadrupole type, to which is applied a combination of RF and DC potentials. The RF frequency and amplitude determine the mass, and the RF/DC ratio determines the filter selectivity. See [Figure 3-2](#).

Figure 3-2 Sensor's Quadrupole Mass Filter



The mass filter's four rods (hence the term "quadrupole") are alternately charged to direct ions of specific masses down through the center, deflecting all larger, and smaller masses (hence the term "mass filter").

The mass filter consists of four parallel rods, or poles, in a square array. The rods, and the insulators in which they are mounted, form an extremely precise mechanical assembly. The distance between the center of the square array and the

closest rod surface is known as the quadrupole radius, with the symbol  $r_0$ . Ideally, the rod should have a hyperbolic shape (towards the center of the assembly) rather than round. The Transpector XPR 3+ quadrupole is machined to have the hyperbolic shape and thus has an optimum electric field for mass filtering ions.

Opposite rods are electrically connected together. The ions are directed into the space between the poles, in a direction nominally parallel to the length of the rods. There the ions are separated according to their mass-to-charge ratios by the lateral forces resulting from the potentials applied to the poles.

The applied potentials consist of an RF component and a DC component. The RF potential on one set of rods is out of phase by  $180^\circ$  with respect to the RF potential on the other set of rods, but of the same amplitude. For one pair of rods, the “X” pair, the DC potential is positive. For the other, the “Y” pair, the DC potential is of the same magnitude but negative. The DC and RF potentials are referenced to a “center voltage” (sometimes called the “pole zero”). The following equations summarize the potentials applied to the rods:

$$X = V \cos(2\pi ft) + U + PZ \quad [1]$$

$$Y = V \cos(2\pi ft + \pi) - U + PZ \quad [2]$$

where:

V is the RF amplitude,

f is the RF frequency,

t is time,

U is the DC potential,

PZ is the pole zero.

The RF component removes the low-mass ions from the beam. Ions of sufficiently low mass have their motions remain in phase with that of the applied RF. These ions will gain energy from the field and oscillate with increasingly large amplitudes. Eventually, as they travel along the length of the rods, they will strike one of the rods and be neutralized. On the other hand, high-mass ions are focused by the RF component to an area close to the quadrupole’s long axis, the “Z” axis.

The DC component is superimposed on the RF to remove high-mass ions from the beam. The DC field deflects the high-mass ions toward the negative poles, opposing the focusing effects of the RF field. Eventually, these high-mass ions strike the negative rods and are neutralized. By a suitable choice of DC-to-RF ratio, the mass filter can be made to discriminate against both high and low-mass ions to the desired degree.

The kinetic energy directed along the Z axis of the mass filter (usually called the ion energy) is primarily dependent on the difference between the potential at which the ions were formed (approximately the anode voltage), and the pole zero. The ion energy is usually only slightly modified by the electric field (the “fringing” field)

between the source exit aperture and the quadrupole. Imbalances in the amplitude of the two phases of RF applied to the rod pairs, and of the DC voltages also applied, result in a further modification of the ion energy.

The mass of the ions passed by the filter is determined by the RF amplitude, the RF frequency, and the quadrupole radius, as shown by the following equation:

$$V = 14.438Mf^2r_0^2 \quad [3]$$

where:

V is the peak-to-peak RF amplitude in Volts,

M the mass of the ion in atomic mass units (AMU) per electron charge,

f the RF frequency in megahertz,

$r_0$  the quadrupole radius in centimeters.

The mass of ions transmitted (M) is directly proportional to the RF amplitude (provided f is constant). As the RF amplitude is increased, progressively higher mass ions will be made to oscillate in phase with the RF field and thus gain sufficient energy to strike the poles. Of course, the DC voltage must also be increased to maintain the high-mass rejection properties of the filter. A mass spectrum can therefore be obtained by sweeping the RF amplitude, along with the DC voltage.

The variation in the efficiency of transmission of ions through the filter with mass is discussed in [section 3.5 on page 3-10](#). Following that, [section 3.6 on page 3-10](#) discusses the behavior of the filter at very low masses where the applied voltages approach zero.

### 3.4.3 The Ion Detector

The ion detector region of the sensor consists of the quadrupole exit lens and the detector itself. Often, the quadrupole exit aperture is biased negatively with respect to the anode, focusing ions that have been transmitted through the quadrupole into the detector element. The detector can be a simple Faraday Cup (FC), an Electron Multiplier (EM), or a combination of both. Transpector XPR 3+ is a combination of Faraday Cup and Electron Multiplier.

#### 3.4.3.1 The Faraday Cup Detector

The Faraday Cup detector is typically a metal plate or a cup-shaped electrode, on which the ion beam impinges. Ions strike the detector and are neutralized, thus drawing a current from the circuitry connected to the electrode. Usually, the current flow that results is exactly equal to the incident ion current. In the Transpector family of instruments, the Faraday Cup is at ground potential.



The sensitivity for Transpector XPR 3+ instruments operating in Faraday Cup mode is typically  $> 4 \times 10^{-7}$  amps per Torr. The minimum detectable partial pressures, therefore, can be as small as  $1 \times 10^{-9}$  Torr in Faraday Cup mode.

#### **3.4.3.2 The Electron Multiplier (EM) Detector**

The Electron Multiplier (EM) acts as an in situ preamplifier for improved sensitivity. Although there are several different types of EM, their operating principals are the same. Incoming ions are accelerated into the input of the EM by a high negative voltage. When an ion strikes the surface of the EM, one or more secondary electrons are emitted. These electrons are accelerated to a second surface which is at a more positive potential, where additional electrons are generated.

This process repeats itself until a pulse of electrons emerges from the output of the EM and is collected on a Faraday Cup. The result is that as many as a million electrons or more can be produced by each incident ion. The current from a Faraday detector is positive (for positive ions) while an EM detector puts out a negative signal.

The ratio of the electron output current to the incident ion current is known as the EM gain. The gain primarily depends on the EM type, the voltage applied to the EM input, the voltage applied across the EM, the condition of the EM, and, to a lesser extent, the mass and chemical nature of the incident ion. In general, the EM gain decreases as the ion mass increases.

The advantage of the EM Sensor is its higher sensitivity, thus making it possible to measure lower partial pressures. A typical Transpector XPR 3+ has an FC sensitivity of about  $4 \times 10^{-7}$  amps/Torr, resulting in a minimum detectable partial pressure of  $1 \times 10^{-9}$  Torr. Operating in EM mode, the Transpector XPR 3+ Sensor has a sensitivity of greater than  $4 \times 10^{-3}$  amps/Torr, resulting in a minimum detectable partial pressure of  $6 \times 10^{-12}$  Torr.

The main disadvantage of the EM Sensor is that the EM gain is less stable and is less precisely known for quantitative measurements.

#### **3.4.3.3 The Transpector XPR 3+ Microchannel Plate, High Pressure Electron Multiplier**

Transpector XPR 3+ uses a Microchannel plate (MCP) High Pressure Electron Multiplier (HPEM)/Faraday Cup detector. The MCP is a small plate (approximately 1/2" (12.7 mm) square by 1/16" (1.6 mm) thick) consisting of an array of over 10,000 very small continuous dynode multipliers, each with a 0.001" (0.03 mm) inside diameter. Refer to [Figure 3-2 on page 3-6](#).

The main advantage of the MCP over other multiplier designs is its smaller size. Also, the required operating voltage is lower.

The MCP does not have to be kept under a vacuum. However, because of the large surface area, the MCP can absorb water vapor and should be protected from exposure to high levels of moisture over extended periods.

When the MCP is grounded, the ions exiting the quadrupole through the exit lens are collected on the Faraday Cup. The resulting current is conducted through the signal output to the detection amplifier. When -1275 V is applied to the front of the MCP, and between -500 and -50 V is applied to the back of the MCP, the ions impinge on the front side of the MCP. The resulting electron current is collected by the same Faraday electrode.

The front of the MCP is fixed at -1275 V in the EM mode for two reasons. First, the ion beam exiting the quadrupole can be strongly divergent, -1275 V ensures that the entire ion beam is deflected into the MCP. Second, if the ion's kinetic energy as it strikes the entrance of the EM is too low, severe mass discrimination effects can occur. The -1275 V avoids both issues.

Use the minimum MCP voltage required to obtain the necessary peak amplitudes and/or signal-to-noise ratio—a gain of 300 is recommended. Operating at higher voltages than necessary will result in premature aging of the Electron Multiplier, requiring early replacement. As the MCP ages, the voltage needed to get a specific EM gain will increase.

### 3.5 Scanning Characteristics

As described above, the quadrupole acts as a mass filter for a mixed beam of ions, rejecting those of both high and low mass, while passing those of an intermediate mass. The selectivity of the mass filter is expressed in terms of resolution,  $R$ , which is numerically given by the ratio of the center mass,  $M$ , to the width,  $\Delta M$  (both in AMU), of the pass band. Since the number of the ions passed by the filter falls off gradually as the edge of the pass band is approached, the width is defined at the point where the ion current falls to some specified fraction (usually 1/2 or 1/10) of the maximum value. The width of the pass band is determined by the DC-to-RF ratio.

While the quadrupole drive circuits can be designed so that  $R$  varies in any desired manner with  $M$ , it is usually most convenient to keep  $\Delta M$  constant at a value, which ensures adequate separation of masses that are 1 AMU apart. This mode of scanning is called Constant  $\Delta M$ . As a result,  $R$  is proportional to  $M$ , and therefore the efficiency with which ions of mass  $M$  are transmitted through the quadrupole decreases with  $M$ . Thus, the sensitivity of the sensor decreases as  $M$  increases.

### 3.6 The Zero Blast

When the mass filter is tuned to very low masses, the RF and DC voltages applied to the rods approach zero. The quadrupole then ceases to act as a filter, and a large current of unseparated ions is detected. This current is called the "zero blast."

The zero blast, present in all quadrupole-based sensors, can interfere with the observation of masses 1 and 2 when significant quantities of higher-mass ions are present. In some instruments, the magnitude of the zero blast is concealed by preventing the voltages from reaching zero.

### 3.7 High Pressure Effects

Since Transpector XPR 3+ is designed to operate at pressures in the milli Torr range, it has some special operating features. The principal difference is that the interaction of ions with the neutral gas molecules in the sensor cannot be neglected.

The interaction of ions with ambient gas molecules is described by the mean-free-path property of the gas environment. The mean-free-path is the average distance that an ion travels before interacting with a gas molecule. The numerical value of the mean-free-path is dependent on the type of ion, the type of gas atmosphere and the gas pressure (i.e. the concentration of gas molecules).

$$\lambda = \frac{K}{P} \quad [1]$$

where:

$\lambda$  is the mean-free-path,

$K$  is a constant depending on the ion and gas species,

$P$  is the pressure of the gas

The mean-free-path grows proportionally shorter as the gas pressure in the sensor increases. The effect of collisions of ions with the gas molecules is to prevent the ions from reaching the collector and being measured. Thus the sensor output is no longer directly proportional to the concentration of the gas species being measured.

The fraction of ions that are able to travel a distance X in a gas is given as:

$$\frac{n}{n_0} = \exp\left(-\frac{X}{\lambda}\right) \quad [2]$$

where:

n is the remaining number of ions after travelling distance X,

n<sub>0</sub> is the original number of ions.

Therefore:

$$\frac{n}{n_0} = \exp\left(-P\left(\frac{X}{K}\right)\right) \quad [3]$$

That is, the fraction of ions in the beam traveling from the ion source decreases with increasing pressure, P, and increasing length, X, of the ion path. This relationship indicates that a high pressure sensor must be made small in order to avoid the loss of ions.

Since the fraction of ion current that is lost is predictable, the data can be linearized by mathematically compensating for the current loss, provided that the current output I of the ion source is proportional to the partial pressure of the ion of interest. An additional linearization term, (1+AP), is used to compensate for the effects of ion space charge in the ion source. Transpector XPR 3+ is equipped to make this linearizing calculation using the total pressure reading of the ion source. The linearization factors F=X/K and A, the ionizer constant, are empirically determined for each Transpector XPR 3+ Sensor for the gas being measured and the electron energy used. The linearized ion current (I<sub>0</sub>) is proportional to the original ions in the source, n<sub>0</sub>, is displayed using the equation:

$$I_0 = I \exp(FP) \times (1 + AP) \quad [4]$$

where:

I is the measured raw ion current,

P is the Transpector XPR 3+ total pressure,

A is the ionizer constant,

F is the linearization factor.

---

## Chapter 4

# Applications Guide

---

### 4.1 How to Interpret the Result

This section explains how to interpret the measurements Transpector XPR 3+ produces. It is divided into three main parts:

- ◆ [Section 4.1.1, Qualitative Interpretation of Mass Spectra, on page 4-1](#), explains how to determine which substances are present in the gas sample being analyzed.
- ◆ [Section 4.1.2, Quantitative Interpretation of Mass Spectra \(Calculating Partial Pressures\), on page 4-9](#), shows how to estimate how much of each substance is present.
- ◆ [Section 4.1.3, Additional Information for Interpreting Mass Spectra, on page 4-15](#), provides additional information that may help you interpret mass spectra.

For a discussion of how Transpector XPR 3+ produces its measurements, refer to [Chapter 3, How The Instrument Works](#).

#### 4.1.1 Qualitative Interpretation of Mass Spectra

The basic graphical output of a residual gas analyzer is the mass spectrum. A mass spectrum is a pattern of peaks on a plot of ion intensity as a function of ion mass-to-charge ratio. Each chemical substance has a characteristic mass spectrum. Different instruments will give slightly different spectra for the same substance. The particular characteristics of the ionizer, mass filter, and detector, not to mention the manner in which the sample is introduced into the mass spectrometer, all influence the spectrum that is produced.

Rarely will a mass spectrum be obtained for a pure substance. Most of the time (especially for residual gas analyzers), the spectrum obtained will be a composite of the individual substances which together comprise the actual sample present. (See [Figure 4-1](#).)

Figure 4-1 Mass spectrum

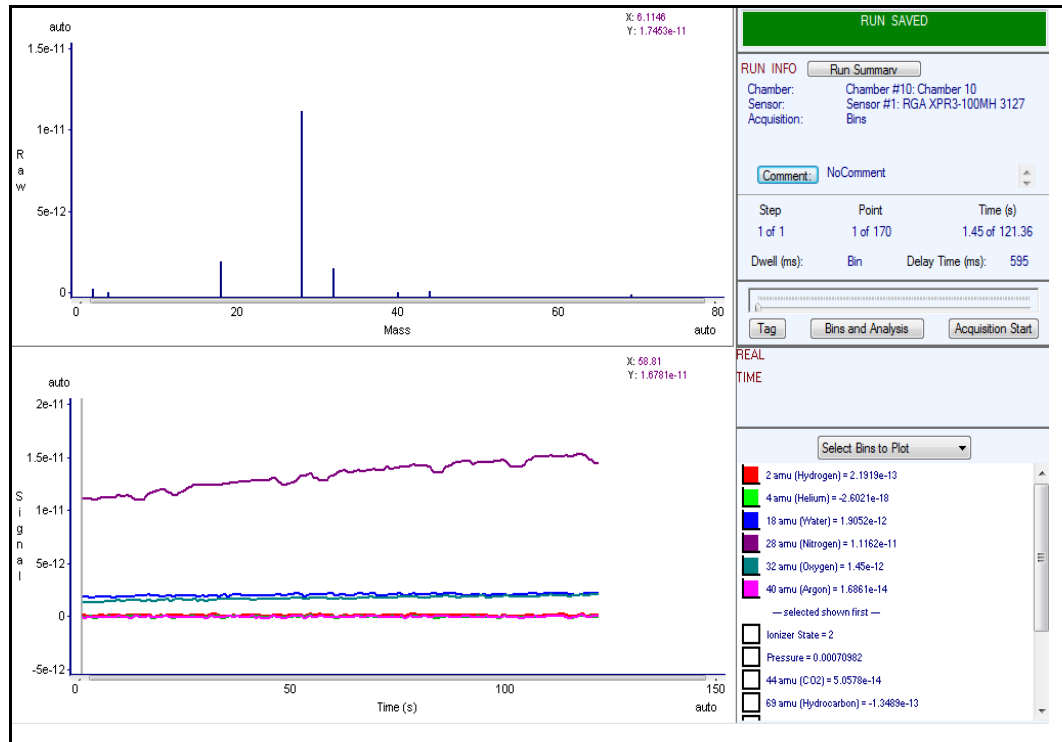


Figure 4-1 is an example of a mass spectrum with an arbitrarily selected number of 170 scans. The top graph shows the data taken during the 170 scans and the selected mass peaks. The bottom graph is a trend analysis showing the most important masses versus time. The prominent peaks for air are mass 28 from Nitrogen, mass 32 from Oxygen, mass 40 from Argon, and mass 18 from water vapor.

### 4.1.1.1 Ionization Process

When a sufficiently energetic electron strikes a gas molecule, there are many processes that can occur, just some of which are summarized in Table 4-1.

Table 4-1 Electron impact ionization processes

$XYZ + e^- \rightarrow$	
$XYZ^+ + 2e^-$	(1)
$XYZ^{2+} + 3e^-$	(2)
$XY + Z^+ + 2e^-$	(3)
$XY^+ + Z + 2e^-$	(4)
$X^+ + YZ + 2e^-$	(5)
$X + YZ^+ + 2e^-$	(6)
$XZ + Y^+ + 2e^-$	(7)
$XZ^+ + Y + 2e^-$	(8)

In all cases, the reactants are a high energy electron,  $e^-$ , and a gas molecule, XYZ. The products of the first reaction are the molecule with a single electron removed (the so-called parent ion) and two low energy electrons. In the second reaction, two electrons are removed from the gas molecule, resulting a doubly charged ion. Triply (or even more highly) charged ions are also possible, provided the incident electron has enough energy.

Reactions 3 through 8 are all examples where the original molecule is broken into fragments, at least one of which is positively charged (negative ions can also be produced in this manner). Only the positive ion fragments are observed; the neutral (i.e., uncharged) fragments are not detected. The mass spectrum obtained when the parent molecule breaks apart under electron impact is commonly referred to as the fragmentation pattern (or, sometimes, the cracking pattern). For example, a fragmentation pattern for Nitrogen shows  $^{14}\text{N}^+$  (14 AMU),  $^{14}\text{N}_2^+$  (28 AMU), and  $^{14}\text{N}^{15}\text{N}^+$  (29 AMU).

In general, peaks from multiply charged species will be less intense than those for the corresponding singly charged ion. For example, the doubly charged peak for argon is typically less than one fifth as intense as the singly charged peak (it should be noted that this intensity ratio is sensitive to the incident electron energy).

There are some situations when it is difficult to determine whether the ion is singly or multiply charged. When a molecule is composed of two atoms of the same element the typical partial pressure analyzer cannot distinguish between the singly charged one-atom fragment ion and the doubly charged two-atom molecular ion, which will both have the same mass-to-charge ratio. Refer to [Figure 4-2 on page 4-6](#); the peak at 28 AMU is the parent ion,  $\text{N}_2^+$ . It is not discernible from this spectrum if the peak at 14 AMU is from  $\text{N}^+$  or  $\text{N}_2^{2+}$ . It has been demonstrated, by other means, that the 14 AMU peak in the nitrogen spectrum is from the singly charged fragment ion.

Most ions (with the important exception of complex hydrocarbons) have masses very close to integer values. When the mass of an ion is not evenly divisible by the number of charges on it, the mass-to-charge ratio will not be an integer. Thus,  $\text{Ar}^{3+}$  will appear at 13.33 AMU, while  $\text{F}^{2+}$  will show up at 9.5 AMU.

#### 4.1.1.2 Isotope Ratios

An additional cause of multiple peaks in the mass spectrum of a pure substance is that most (but not all) elements are composed of more than one isotope. For example, 99.63% of all nitrogen atoms in nature have a mass of 14 AMU; only 0.37% have a mass of 15 AMU. Carefully examine the nitrogen spectrum in [Figure 4-2 on page 4-6](#). The largest peak at 28 AMU is the parent ion,  $N_2^+$ . The peak at 29 AMU is the isotope peak,  $^{14}N^{15}N^+$ , and is 0.74% (two times 0.37%) as high as the parent peak since there are two nitrogen atoms in the ion, each one of which has a 0.37% chance of being 15 AMU.

Some elements have many intense isotopes (e.g., xenon is 0.096% mass 124, 0.090% mass 126, 1.92% mass 128, 26.44% mass 129, 4.08% mass 130, 21.18% mass 131, 26.89% mass 132, 10.44% mass 134, and 8.87% mass 136).

Isotope ratios, like fragmentation patterns, are a very useful aid in recognizing specific materials. Under normal partial pressure analyzer ionization conditions, the peak height ratios for the various isotopes of an element will be the same as the ratios of their natural abundance's. That is, the probability of ionizing, for example, the mass 35 isotope of chlorine ( $^{35}Cl$ ) is the same as the probability of ionizing the mass 37 isotope ( $^{37}Cl$ ). Thus, the peak height ratio of mass 35 to 37 from HCl will be 3.07 to 1 (75.4% / 24.6%).

For a listing of the isotopic ratios for the lighter elements, see [Table 4-2](#). For a complete listing of the natural abundances for the isotopes of all the elements, see the *Handbook of Chemistry and Physics* from CRC Press.



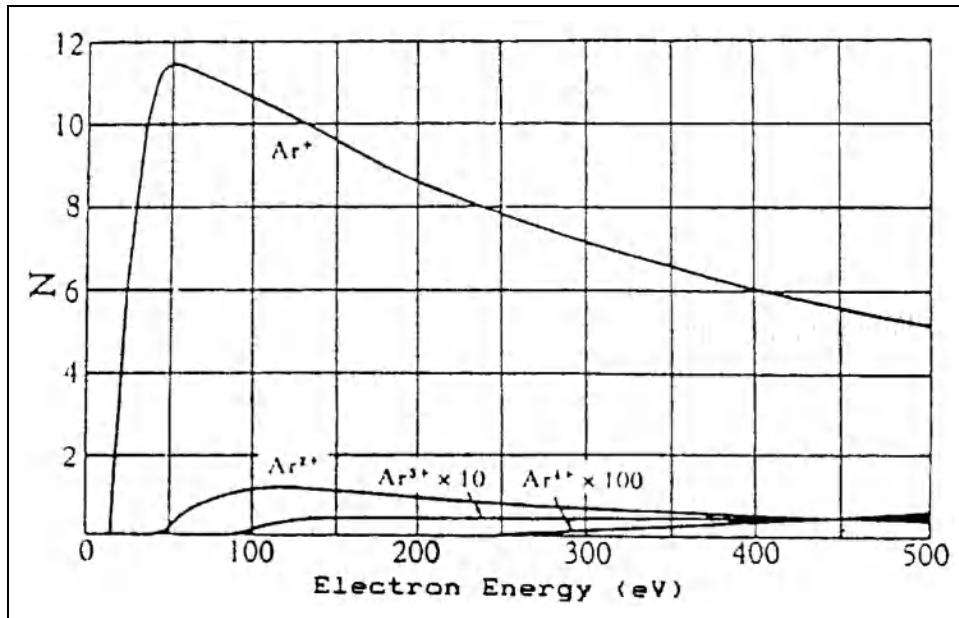
Table 4-2 Isotope ratios

Isotope Ratios		
Element	Mass No.	Relative Abundance
H	1	99.985
	2	0.015
He	3	0.00013
	4	~100.0
B	10	19.78
	11	80.22
C	12	98.892
	13	1.108
N	14	99.63
	15	0.37
O	16	99.759
	17	0.0374
	18	0.2039
F	19	100.0
Ne	20	90.92
	21	0.257
	22	8.82
Na	23	100.0
Al	27	100.0
Si	28	92.27
	29	4.68
	30	3.05
P	31	100.0
S	32	95.06
	33	0.74
	34	4.18
	36	0.016
Cl	35	75.4
	37	24.6
Ar	36	0.337
	38	0.063
	40	99.600

### 4.1.1.3 Electron Energy Effects

As was previously mentioned, the exact fragmentation pattern observed will depend on the energy of the bombarding electrons. Figure 4-2 (from a paper by W. Bleakney, *Physical Review*, 36, p. 1303, published in 1930) graphs the number of argon ions (of different charge states) produced per incident electron per Torr of gas pressure as a function of electron energy.

Figure 4-2 Electron energy effects



This graph shows the number of argon ions, N, formed per electron per Torr at 0 °C versus electron energy.

The appearance potential (i.e., the minimum electron energy required to produce a specific ion) for Ar<sup>+</sup> is 15.7 eV. The number of argon ions produced rises steeply with energy until a maximum is reached at about 55 eV. As the electron energy rises above this level, the rate of Ar<sup>+</sup> production slowly decreases.

The appearance potential for Ar<sup>2+</sup> is 43.5 eV, and the ion production rate does not maximize until the electron energy exceeds 100 eV. The appearance potential for Ar<sup>3+</sup> is approximately 85 eV, while the appearance potential for Ar<sup>4+</sup> is over 200 eV. Transpector XPR 3+ normally is set for 40 eV (Low Emission) setting to produce Ar<sup>+</sup> ions. The low electron energy (40 eV) model of Transpector XPR 3+ operation suppresses production of <sup>36</sup>Ar<sup>2+</sup> ions at mass 18, resulting in the mass 18 current being principally a measure of H<sub>2</sub>O.

#### 4.1.1.4 A Qualitative Interpretation Guide

To use a partial pressure analyzer to identify unknown substances, you must recognize three characteristics: fragmentation patterns, multiply charged ions, and isotope ratios. Simple spectra are, in general, relatively easy to interpret and will yield useful identifications. The analysis of complicated mixtures of substances is much more difficult.

Table 4-3 is intended as a spectrum interpretation guide which may be of use when first examining an unknown spectrum. The guide lists the masses of peaks, possible ion identities for each of these masses, and common sources for each of these ions.

**NOTE:** This list is by no means all-inclusive.

Table 4-3 Spectrum Interpretation Guide

Spectrum Interpretation Guide		
AMU #	Chemical Symbol	Sources
1	H	Water F or Hydrogen F
2	H <sub>2</sub> , D	Hydrogen, Deuterium ( <sup>2</sup> H)
3	HD, <sup>3</sup> H	Hydrogen-Deuterium, Tritium ( <sup>3</sup> H)
4	He	Helium
5	No known elements	
6	C	Doubly Ionized <sup>12</sup> C (Rare)
7	N	DI <sup>14</sup> N (Rare)
8	O	DI <sup>16</sup> O (Rare)
9	No known elements	
10	Ne, <sup>10</sup> B	DI <sup>20</sup> Ne (Rare), BF <sub>3</sub> , BCl <sub>3</sub>
11	Ne, <sup>11</sup> B	DI <sup>22</sup> Ne (Rare), <sup>11</sup> BF <sub>3</sub> , BCl <sub>3</sub>
12	C	Carbon, Carbon Monoxide F, Carbon Dioxide F
13	CH, <sup>13</sup> C	Methane F, Carbon Isotope
14	N, CH <sub>2</sub>	Nitrogen, Methane F or Note 1
15	CH <sub>3</sub>	Methane F or Note 1
16	O, CH <sub>4</sub> , NH <sub>2</sub>	Oxygen or Carbon Monoxide F, Ammonia
17	OH, NH <sub>3</sub>	Water F, Ammonia F
18	H <sub>2</sub> O	Water
19	F	Fluorine or Freon F
20	Ar <sup>2+</sup> , Ne, HF	Argon DI, Neon, Hydrofluoric Acid

Table 4-3 Spectrum Interpretation Guide (continued)

Spectrum Interpretation Guide		
AMU #	Chemical Symbol	Sources
21		
22	<sup>22</sup> Ne, CO <sub>2</sub>	Neon, DI CO <sub>2</sub>
23		
24	C <sub>2</sub>	See Note 1
25	C <sub>2</sub> H	See Note 1
26	C <sub>2</sub> H <sub>2</sub> CN	See Note 1, Hydrogen Cyanide F
27	C <sub>2</sub> H <sub>3</sub> , Al, HCN	See Note 1, Aluminum, Hydrogen Cyanide
28	N <sub>2</sub> , CO, C <sub>2</sub> H <sub>4</sub> , Si	Nitrogen, Carbon Monoxide, Ethylene P, Silicon
29	CH <sub>3</sub> CH <sub>2</sub>	Ethane F or Ethanol F or Isopropyl Alcohol
30	C <sub>2</sub> H <sub>6</sub> , NO	Ethane P, Nitric Oxide
31	P, CH <sub>2</sub> OH,	Oxygen, Methanol F,
32	O <sub>2</sub> , S	Oxygen, Sulfur, Methanol P
33	HS	Hydrogen Sulfide F
34	H <sub>2</sub> S, <sup>34</sup> S, O <sub>2</sub>	Hydrogen Sulfide P, Sulfur Isotope, Oxygen Isotope
35	Cl	Chlorine Isotope, See Note 2
36	HCl, <sup>36</sup> Ar, C <sub>3</sub>	Hydrochloric Acid, Argon Isotope, Hydrocarbons
37	<sup>37</sup> Cl, C <sub>3</sub> H	Chlorine Isotope, See Note 2, Hydrocarbons
38	<sup>37</sup> HCl, C <sub>3</sub> H <sub>2</sub>	Hydrochloric Acid or See Note 2, Hydrocarbons
39	C <sub>3</sub> H <sub>3</sub>	See Note 3, Hydrocarbons
40	Ar, C <sub>3</sub> H <sub>4</sub>	Argon, See Note 1, Hydrocarbons
41	C <sub>3</sub> H <sub>5</sub>	See Note 1, Hydrocarbons
42	C <sub>3</sub> H <sub>6</sub>	See Note 1, Hydrocarbons
43	C <sub>3</sub> H <sub>7</sub> , CH <sub>3</sub> CO	Note 1, Acetone F or Methyl Ethyl Ketone F
44	CO <sub>2</sub> , C <sub>3</sub> H <sub>8</sub>	Carbon Dioxide, See Note 3
45	CH <sub>3</sub> CH <sub>2</sub> O	Ethanol F or Isopropyl Alcohol F
46	CH <sub>3</sub> CH <sub>2</sub> OH	Ethanol P
47	C <sup>35</sup> Cl	See Note 2
48	HC <sup>35</sup> Cl, SO	See Note 2, Sulfur Dioxide F

Table 4-3 Spectrum Interpretation Guide (continued)

Spectrum Interpretation Guide		
AMU #	Chemical Symbol	Sources
49	C <sup>37</sup> Cl	See Note 2
50	C <sup>37</sup> Cl, CF <sub>2</sub> , C <sub>4</sub> H <sub>2</sub>	See Note 2, Freon F, Note 3
<p><b>NOTES:</b> (1) Fragments of several hydrocarbons, such as mechanical pump oil, diffusion pump oil, vacuum grease, cutting oil, and organic solvents.  (2) Fragments of several chlorinated hydrocarbons, such as carbon tetrachloride, tichloroethylene, and many freons.  (3) Fragments from both straight chain hydrocarbons and benzene ring hydrocarbons.  (4) F = Fragment ion; P = Parent ion; DI = Doubly ionized</p>		

#### 4.1.2 Quantitative Interpretation of Mass Spectra (Calculating Partial Pressures)

Partial pressure is defined as the pressure of a designated component in a gas mixture. By Dalton's Law, the sum of all the partial pressures is the total pressure. The partial pressure analyzer is designed so that the height of a peak in a mass spectrum is proportional to the number of ions giving rise to that peak. Also by design, the number of ions is more or less proportional to the partial pressure of the substance giving rise to that peak (over some specified operating pressure range). Therefore, the height of a peak is proportional to the partial pressure of the substance giving rise to that peak.

The following equation shows the relationship between the partial pressure of substance determined by measuring the ion current at mass b:

$$PP_a = K_{ab} \times I_{ab} \quad [1]$$

The partial pressure of substance a is symbolized by  $PP_a$ , while  $K_{ab}$  is the proportionality constant for the peak at mass b from substance a, and  $I_{ab}$  is the ion current at mass b from substance a.

The proportionality constant,  $K_{ab}$ , depends on the nature of the substance being detected and on the characteristics of the partial pressure analyzer. The substance-dependent part is called the material factor,  $M_{ab}$ . The instrument-dependent part is called the analyzer factor,  $A_b$ , and depends primarily on the ion mass, b. Therefore, the original equation [1] can therefore be rewritten as follows:

$$PP_a = (M_{ab} \times A_b) \times I_{ab} \quad [2]$$

The material factor,  $M_{ab}$ , depends on the fragmentation pattern for the particular substance, the fragmentation pattern for a reference gas (usually nitrogen), and the ease with which the substance can be ionized relative to the same reference gas. The relationship involved is shown in [equation \[3\]](#):

$$M_{ab} = \frac{1}{FF_{ab} \times XF_a} \quad [3]$$

The term  $FF_{ab}$  is the fragmentation factor for substance a at mass b. It is equal to the fraction of the total current of all ions from substance a which have a mass b. Finally,  $XF_a$  is the ionization probability of substance a, relative to nitrogen (i.e.,  $XF_N=1$ ). That is, it is the ratio of total ion current (for all masses) from substance a to the total ion current from nitrogen, both measured at the same true partial pressure. Both fragmentation factors and ionization probabilities depend strongly on the energy of the ionizing electrons. If the correct values of these factors are not known for the exact conditions of the particular analyzer being used, they can be approximated using published values for other conditions with, generally, only a small loss in accuracy.

Fragmentation factors can be calculated from fragmentation patterns given in the general references cited in [Chapter 9](#). Other valuable references include the Index of Mass Spectral Data from ASTM, and EPA/NIH Mass Spectral Data Base by Heller and Milne and an extensive library of spectra is available from the National Institute of Standards and Technology (formerly the National Bureau of Standards).

[Table 4-4](#) lists the fragmentation factors (FF) for the major peaks for selected substances.

**NOTE:** Actual fragmentation factors vary significantly depending especially on the ionizer, electron energy, and mass filter turning. For best accuracy, measure fragmentation factors with the same instrument used for the analysis, under the same tuning conditions.

Table 4-4 Typical fragmentation factors for the major peaks of some common substances

Mass	FF	Mass	FF	Mass	FF
Acetone (CH <sub>3</sub> ) <sub>2</sub> CO		Helium He		Oxygen O <sub>2</sub>	
43	.63	4	1.00	32	.95
58	.23			16	.05
42	.04	Hydrogen H <sub>2</sub>			
27	.03	2	1.00	Toulene C <sub>2</sub> H <sub>5</sub> CH <sub>3</sub>	
				91	.46
Argon Ar				92	.34
40	.83	Krypton Kr		60	.07
20	.17	84	.45	65	.05
		86	.13		
Benzene C <sub>6</sub> H <sub>6</sub>		82	.10	Trichlorethylene C <sub>2</sub> HCl <sub>3</sub>	
78	.53	83	.10	95	.22
51	.11			130	.22
52	.11	Methane CH <sub>4</sub>		132	.21
50	.10	16	.46	97	.14
		15	.40	60	.13
Carbon Dioxide CO <sub>2</sub>		14	.07		
44	.70	13	.04	Water H <sub>2</sub> O	
28	.11			18	.75
16	.06	Methanol CH <sub>3</sub> OH		17	.19
12	.01	31	.43	1	.05
		32	.23	16	.02
Carbon Monoxide CO		29	.18		
28	.91	28	.03	Xenon Xe	
12	.05			132	.26
16	.03	Neon Ne		129	.26
		20	.90	131	.22
Ethanol C <sub>2</sub> H <sub>5</sub> OH		22	.10	134	.11
31	.49			136	.09
45	.21	Nitrogen N <sub>2</sub>			
27	.09	28	1.00		
29	.07	14	.12		
		29	.01		

Ionization probability factors can be approximated by substituting the relative ion gauge sensitivities for various gases. [Table 4-5](#) gives relative ion gauge sensitivities for some common gases.

**NOTE:** This table lists relative ionization gauge sensitivities for selected molecules. The data was compiled from *Empirical Observations on the Sensitivity of Hot Cathode Ionization Type Vacuum Gauges* by R. L. Summers (NASA Technical Note NASA TN D5285, published in 1969). Similar, although more limited, lists of ionization sensitivities can be found in the books by O'Hanlon (Chapter 8, Section 1.1) and Drinkwine and Lichtman (Table I, page 5).

**HINT:** Actual ionization probabilities vary significantly depending especially on the ionizer and the electron energy. For best accuracy, measure the relative ionization probability using a hot cathode ionization gauge (calibrated for nitrogen) to monitor a known pressure of the substance of interest. The ratio of the gauge reading to the known true pressure is the relative ionization probability. To determine the true pressure, use a gauge which is gas species independent (for example, a capacitance manometer) or a gauge with a known sensitivity factor (for example, a spinning rotor gauge).



Table 4-5 Ionization probabilities for some common substances

Substance	Formula	Relative Ionization Gauge Sensitivity	Substance	Formula	Relative Ionization Gauge Sensitivity
Acetone	$(\text{CH}_3)_2\text{CO}$	3.6	Hydrogen chloride	HCl	1.6
Air		1.0	Hydrogen fluoride	HF	1.4
Ammonia	$\text{NH}_3$	1.3	Hydrogen iodide	HI	3.1
Argon	Ar	1.2	Hydrogen sulfide	$\text{H}_2\text{S}$	2.2
Benzene	$\text{C}_6\text{H}_6$	5.9	Krypton	Kr	1.7
Benzoic acid	$\text{C}_6\text{H}_5\text{COOH}$	5.5	Lithium	Li	1.9
Bromine	$\text{Br}_2$	3.8	Methane	$\text{CH}_4$	1.6
Butane	$\text{C}_4\text{H}_{10}$	4.9	Methanol	$\text{CH}_3\text{OH}$	1.8
Carbon dioxide	$\text{CO}_2$	1.4	Neon	Ne	0.23
Carbon disulfide	$\text{CS}_2$	4.8	Nitrogen	$\text{N}_2$	1.0
Carbon monoxide	CO	1.05	Nitric oxide	NO	1.2
Carbon tetrachloride	$\text{CCl}_4$	6.0	Nitrous oxide	$\text{N}_2\text{O}$	1.7
Chlorobenzene	$\text{C}_6\text{H}_5\text{Cl}$	7.0	Oxygen	$\text{O}_2$	1.0
Chloroethane	$\text{C}_2\text{H}_5\text{Cl}$	4.0	n-Pentane	$\text{C}_5\text{H}_{12}$	6.0
Chloroform	$\text{CHCl}_3$	4.8	Phenol	$\text{C}_6\text{H}_5\text{OH}$	6.2
Chloromethane	$\text{CH}_3\text{Cl}$	3.1	Phosphine	$\text{PH}_3$	2.6
Cyclohexane	$\text{C}_6\text{H}_{12}$	6.4	Propane	$\text{C}_3\text{H}_8$	3.7
Deuterium	$\text{D}_2$	0.35	Silver perchlorate	$\text{AgClO}_4$	3.6
Dichlorodifluoromethane	$\text{CCl}_2\text{F}_2$	2.7	Stannic iodide	$\text{SnI}_4$	6.7
Dichloromethane	$\text{CH}_2\text{Cl}_2$	7.8	Sulfur dioxide	$\text{SO}_2$	2.1
Dinitrobenzene	$\text{C}_6\text{H}_4(\text{NO}_2)_2$	7.8	Sulfur hexafluoride	$\text{SF}_6$	2.3
Ethane	$\text{C}_2\text{H}_6$	2.6	Toluene	$\text{C}_6\text{H}_5\text{CH}_3$	6.8
Ethanol	$\text{C}_2\text{H}_5\text{OH}$	3.6	Trinitrobenzene	$\text{C}_6\text{H}_3(\text{NO}_2)_3$	9.0
Ethylene oxide	$(\text{CH}_2)_2\text{O}$	2.5	Water	$\text{H}_2\text{O}$	1.0
Helium	He	0.14	Xenon	Xe	3.0
Hexane	$\text{C}_6\text{H}_{14}$	6.6	Xylene	$\text{C}_6\text{H}_4(\text{CH}_3)_2$	7.8
Hydrogen	$\text{H}_2$	0.44			

The analyzer factor,  $A_b$ , depends on the transmission and detection characteristics of the analyzer, the Electron Multiplier gain (if the analyzer is so equipped), and the basic sensitivity, as indicated in [equation \[4\]](#):

$$A_a = \frac{1}{TF_b \times DF_{ab} \times G \times S} \tag{4}$$

Here,  $TF_b$  is the transmission factor of the mass filter at mass  $b$ . The transmission factor is the fraction of ions at mass  $b$  which pass through the mass filter, relative to nitrogen ions at mass 28. Nominally, the transmission factor is equal to 28 divided by the mass of the ion,  $b$ .

The detection factor,  $DF_{ab}$ , is equal to 1 for a Faraday Cup detector. For an Electron Multiplier, the detection factor is a function of the mass of the ion and its chemical nature, and is measured relative to that of a reference gas, typically nitrogen. In general, as the mass ion increases, the Electron Multiplier detection factor decreases.

The gain of the Electron Multiplier,  $G$ , measured at mass 28 for nitrogen, is the Electron Multiplier output current divided by the Faraday mode output current, under otherwise identical conditions. The multiplier gain is a strong function of the high voltage applied.

The sensitivity of the instrument,  $S$ , is the ratio of Faraday mode ion current for a given pressure of pure nitrogen measured at mass 28, and is typically expressed in amps/Torr.

The overall relation between partial pressure and ion current, given in [equation \[5\]](#), is quite general. The constants for this equation can be obtained from various tables, but for the best accuracy, they should be measured for each instrument.

$$PP_a = \left\{ \frac{FF_{N28}}{FF_{ab} \times XF_{ab} \times TF_b \times DF_{ab} \times G \times S} \right\} \times I_{ab} \tag{5}$$

A brief discussion of each of the terms follows:

- $PP_a$  ..... Partial pressure of substance  $a$  (usually in Torr).
- $FF_{ab}$  ..... Fragmentation factor, or fraction of total ion current from substance  $a$  having mass  $b$  (dimensionless; see [Table 4-4 on page 4-11](#)).
- $FF_{N28}$  ..... Fragmentation factor for  $N_{2+}$  ions at 28 AMU from nitrogen (dimensionless; typically around 0.9).

$X_{F_a}$ . . . . .	Ionization probability of substance a relative to nitrogen; approximately the same as the relative ion gauge sensitivity as shown in (dimensionless).
$T_{F_b}$ . . . . .	Transmission factor, the fraction of total ions at mass b which pass through the mass filter, relative to ions with a mass of 28 AMU; nominally, $T_{FM} = 28 / M$ (dimensionless).
$D_{F_{ab}}$ . . . . .	Detection factor for mass b ions from substance a, relative to nitrogen at 28 AMU; assumed to be 1.00 for Faraday detectors, but varies for Electron Multiplier detectors (dimensionless).
$G$ . . . . .	Electron Multiplier gain for nitrogen ions at 28 AMU (dimensionless; set equal to 1 for a Faraday Cup detector).
$S$ . . . . .	Sensitivity of instrument to nitrogen, the ion current at 28 AMU per unit of nitrogen partial pressure (usually in amps/Torr).
$I_{ab}$ . . . . .	Ion current of mass peak b resulting from substance a (in amps; assumes that there are no other substances present which contribute significantly to the total current at mass peak b).

### 4.1.3 Additional Information for Interpreting Mass Spectra

The following paragraphs contain additional information which may be of use when interpreting mass spectra.

#### 4.1.3.1 Ion source Characteristics

It is important to recognize that the partial pressure analyzer (especially the ion source) and the vacuum system configuration can both have an effect on the relative concentrations of the gases detected. In order to minimize these effects, it is necessary to have the right type of ionizer, the right type of filament, and the right configuration of the vacuum system. This is particularly true when a differential pumping arrangement is used because the pressure of the gas to be sampled is too high for the Sensor to operate. J. O'Hanlon's book, *A User's Guide to Vacuum Technology*, has a brief discussion (in Chapter 8, Section 2) of some of these concerns.

There are four classes of interactions between the sensor and the immediate vacuum environment which can have a significant effect on the detected gas composition.

First, the analyzer itself is a source of gas molecules because of outgassing from its surfaces. Usually, the outgassing levels can be reduced by baking the analyzer in vacuum. When operating in the ultrahigh vacuum (UHV) region, it is best to bake the sensor overnight at the maximum permissible temperature with the electronics removed. See the bakeout temperature specifications for the Transpector XPR 3+ sensor. A second overnight bakeout should be performed at the maximum sensor operating temperature. (It can take more than three hours for all parts of the sensor to reach maximum temperature during a bakeout, and more than six hours to cool back down.)



### CAUTION

**Make sure that the Electron Multiplier high voltage is turned off for this (second) bakeout temperature, otherwise, permanent damage to the EM may result.**

Second, it is possible that the opposite of outgassing can occur; that is, gas molecules can be captured by the surfaces of the sensor. This effect is called “pumping.” In such cases, the magnitude of the signals of the gases pumped will be lower than is properly representative of the composition of the gas in the vacuum chamber.

Third, reactions involving gas molecules on surfaces of the analyzer can result in a change of composition. Gases can either be consumed by the surfaces, or produced by the surfaces. One example of gas consumption is the reaction of oxygen with a hot filament, particularly when tungsten filaments are used. The typical result is an anomalously low concentration of oxygen detected. See O’Hanlon’s book (Chapter 8, Section 2) for more information on filament materials and their interactions with the gas being analyzed. An example of gases being produced from surfaces is the liberation of carbon monoxide molecules from a thorium oxide coated iridium filament by a sputtering mechanism in the presence of significant quantities of argon. This latter mechanism makes the combination of a pressure reduction system and an RGA Sensor unsuitable for measuring nitrogen contamination in argon at the low parts-per-million (PPM) level from a sputter deposition process. A special type of inlet system and ion source (often referred to as a Closed Ion Source [CIS]) should be used for this type of application.

Fourth, there are cases where at least some of the ions detected are emitted from surfaces in the ion source under electron bombardment, and are not generated in the gas phase from neutral molecules. This process is known as electron stimulated desorption (ESD), or sometimes as electron induced desorption (EID).

When the sensor has been exposed to fluorine containing substances (such as sulfur hexafluoride, chlorofluorocarbons, perfluorotributylamine, or perfluorokerosene) for extended periods of time, it is not uncommon for a strong  $F^+$  peak at 19 AMU to remain even after the fluorine containing substance has been removed. When operating in the UHV region, EID/ESD of  $H^+$ ,  $C^+$ ,  $O^+$ , and  $CO^+$  (and other ions) is not uncommon. The clue to diagnosing this problem is that the observed fragmentation patterns do not match known gas phase patterns. See pages five and six, and typical spectra TS2 through 5, 16, 28, and 30 of *Partial Pressure Analyzers and Analysis* by Drinkwine and Lichtman for more information on EID/ESD.

Partial pressure analyzers are also characterized by varying degrees of mass discrimination; that is, the sensitivity of the instrument is a function of mass. Ion sources show mass discrimination because various substances offer different degrees of difficulty of ionization. Generally, heavy, large molecules are ionized more readily than light, small molecules. There is a rough correlation between the number of electrons in a molecule and its ease of ionization. Although the total ion yield (i.e., the sum of ions of all masses) is electron energy and ionizer dependent, a reasonable estimate for the number of ions produced (relative to some standard, usually nitrogen) in a partial pressure analyzer is the relative ionization gauge sensitivity.

#### 4.1.3.2 Scanning Characteristics

Quadrupole mass filters can also exhibit mass discrimination characteristics depending on how the control voltages are varied during the sweep through the mass range. Most instruments are designed to operate with a constant peak width (constant  $\Delta M$ ) which results in a resolution which is proportional to the mass. This characteristic provides a good degree of peak separation throughout the mass spectrum, but results in an ion transmission efficiency (i.e., the fraction of all ions of the selected mass entering the mass filter which are transmitted through it) that decreases as mass increases.

The way the mass scale is “calibrated” or “tuned” (i.e., the way the peak positions and widths are adjusted) can have a significant effect on the transmission efficiency of the mass filter across the mass spectrum. If the adjustments are not made properly, the ratios of peak heights across the mass range will not be correct.

#### 4.1.3.3 Fragmentation Factors

The fragmentation factor is the fraction of the total ion current contributed by ions of the chosen mass. Only peaks contributing at least one percent to the total ion current are included in the list. The sum of the factors for all the peaks in a mass spectrum cannot exceed 1.00. The sum can be less than 1.00 if only some of the peaks are listed (either there are many peaks, or some of the ions produced lie outside the mass range of the particular instrument used).

The data presented earlier in [Table 4-4 on page 4-11](#), [Typical fragmentation factors for the major peaks of some common substances](#), is compiled from more than one source and is for illustrative purposes only. For maximum accuracy in determining partial pressures, the fragmentation factors for the substances of interest should be measured with the same instrument, and the same adjustments, as the samples to be analyzed.

#### 4.1.3.4 High Pressure Effects

As described in [Section 3.7, High Pressure Effects, on page 3-11](#), when approaching the high pressure limit of operation the ion current does not increase linearly with pressure because of ion losses that are pressure dependent. The degree of ion loss depends on the nature of the ion in question and the nature of the total gas environment in the sensor. If conditions are sufficiently defined, i.e. the type of major gases and the interaction with the ion of interest, it is possible to compensate mathematically for the non-linear behavior at the high pressure end of the range. Transpector XPR 3+ permits the user to make such a compensation using the total pressure sensed by the ion source and an empirically determined factor for specific gases. Even when the exact factor is not known, the compensated results are typically more nearly accurate than the raw data.

## Chapter 5

# Transpector XPR 3+ Operation and Best Known Methods

### 5.1 Introduction

Once the Transpector XPR 3+ Sensor, Electronics Module, Isolation Valve, and Pirani Interlock are installed, the isolation valve should be opened to allow Transpector XPR 3+ to obtain high vacuum. It is strongly recommended that Transpector XPR 3+ be kept under high vacuum conditions for at least eight hours before the filament is turned on. It is also recommended that Transpector XPR 3+ be baked out with the supplied heating jacket (which operates at 150 °C), for a period of at least eight hours. This eight hour minimum bakeout is required to reduce residual water vapor levels that may be higher due to local surface outgassing effects. These recommendations should be followed whenever Transpector XPR 3+ Sensor is exposed to atmosphere for long periods of time and will serve to increase sensor life.

Table 5-1 Transpector XPR 3+ Sensor maximum bakeout temperature

Sensor	Maximum Operating Temperature	Maximum Bakeout Temperature Electronics Removed
Transpector XPR 3+	150 °C	200 °C



#### CAUTION

Do not turn on electron multiplier high voltage at sensor temperatures above 150 °C. Permanent damage to the electron multiplier could result.



#### WARNING

During or immediately after bakeout, the heating jacket and metal surfaces in the vicinity of the heating jacket may be hot. These surfaces may exceed 100 °C at the maximum ambient operating temperature (i.e., 50 °C), which will cause burns if touched directly without using the proper personal protection equipment.

## 5.2 Precautions for Operation

There are some precautions that the operator should take to maintain sensor performance and extend filament life. It is recommended that the Transpector XPR 3+ filament emission be turned off manually, before maintenance, to allow cooling before exposure to the vent gas. If manual shutdown does not happen, the interlock will turn off the filament when the vent gas is introduced.

The point of greatest risk to air exposure is after maintenance where the process chamber has been exposed to air. Recommended operation after maintenance is to pump down the chamber and Transpector XPR 3+ Sensor followed by a bakeout with the Transpector XPR 3+ Sensor heater (and isolation valve heater, if present). Following bakeout and cool down, the base pressure should be  $< 10^{-6}$  Torr for safe turn on of the filament.

See [Chapter 7](#) for specific Maintenance Procedures.

## 5.3 Pirani Interlock Protection

Filament interlock protection for Transpector XPR 3+ allows the XPR 3+ filament emission to operate at safe pressures ( $< 2 \times 10^{-2}$  Torr) by action of the Pirani Emission OFF Interlock function. Protection is provided by a Pirani gauge, which directly monitors pressure at the XPR 3+. Interlock protection turns off the XPR 3+ filament if the pressure increases above a maximum operating limit ( $< 2 \times 10^{-2}$  Torr) and does not allow the filament to be turned on when pressures exceed this limit. This chapter describes the interlock apparatus and its operation.

Interlock Protection:

- ◆ prevents inadvertent turn on of the XPR 3+ emission at high pressures,
- ◆ safely turns off the XPR 3+ filament when process pressures exceed a selected pressure (the default / maximum value is 20 mTorr), and
- ◆ (optionally) turns the XPR 3+ emission on at a different safe pressure (the default for this option is OFF).

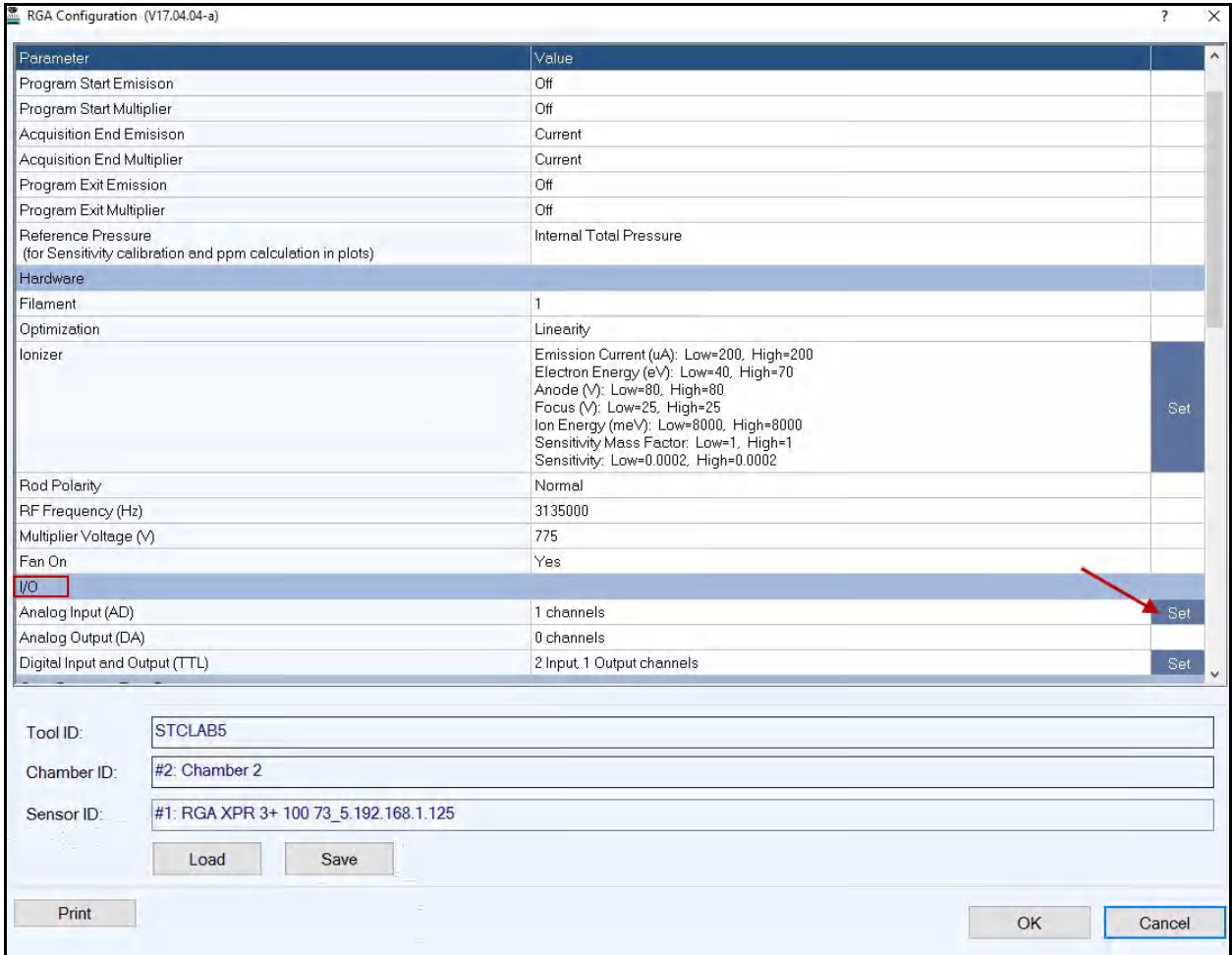
## 5.4 FabGuard Control

### 5.4.1 Transpector XPR 3+ Configuration— I/O Tab

Transpector XPR 3+ RGAs have one analog input for bringing in data from devices such as external pressure gauges. The **I/O** section configures the analog input.



Figure 5-1 RGA Configuration - External I/O tab



**Name**

In the **Name** box, enter a name for the analog input. (See Figure 5-2.)

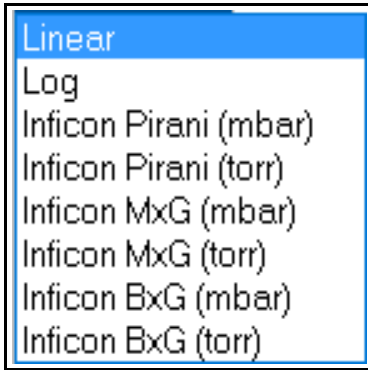
Figure 5-2 Name



**Signal Type**

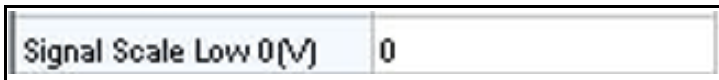
In the item list, click the signal type.

Figure 5-3 Signal type



**0 Volt Input**

Figure 5-4 0 volt input =



Defines what an input of 0 volts means in user units. If the **Signal Type** is **INFICON Pirani**, **MxG**, or **BxG**, the **0 volt input =** value cannot be changed.

**10 Volt Input**

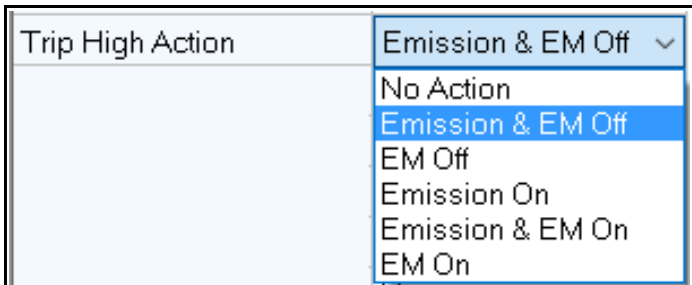
Figure 5-5 10 volt input



Defines what an input of 10 volts means in user units. If the **Signal Type** is **INFICON Pirani**, **MxG**, or **BxG**, the **10 volt input =** value cannot be changed.

**High Trip Action**

Figure 5-6 High Trip Action



**High Trip Action** is typically used to stop emission from turning on at pressures too high for safe operation.

**NOTE:** **High Trip Action** offers protection in addition to the Total Pressure Interlock in Transpector firmware if Emission and EM Off are selected.

**High Trip Level**

Figure 5-7 High trip level

Trip High Level	4
-----------------	---

Defines the **High Trip Level**. If **INFICON Pirani, MxG, or BxG** option is selected as the **Signal Type**, the value will be in Torr or millibar depending upon the units selected in the **Signal Type** list.

**Low Trip Action**

Figure 5-8 Low trip action

Trip Low Action	Emission & EM Off
	No Action
	Emission & EM Off
	EM Off
	Emission On
	Emission & EM On
	EM On

Defines the action that occurs when the **Low Trip Level** is reached. **Low Trip Action** is typically used to protect the sensor in case the pressure gauge fails, or the pressure gauge cable becomes disconnected.

**NOTE: Low Trip Action** will act as an emission interlock when set to a pressure value below the minimum value possible for the pressure gauge, and Emission and EM Off are selected.

**Low Trip Level**

Figure 5-9 Low Trip Level

Trip Low Level	0.5
----------------	-----

Defines the **Low Trip Level**. If **INFICON Pirani, MxG, or BxG** option is chosen as the **Signal Type**, the value will be in units of Torr or millibar depending upon the units selected in **Signal Type**.

**Flex Trip Action**

Figure 5-10 Flex Trip Action

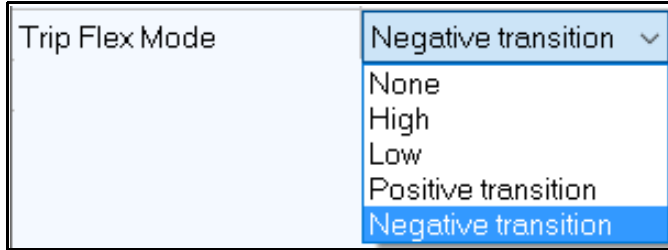
Trip Flex Action	Emission & EM On
	No Action
	Emission & EM Off
	EM Off
	Emission On
	Emission & EM On
	EM On

Defines the action that occurs when the **Flex Trip Level** is reached. **Flex Trip Level** is typically used in FabGuard to turn the Emission and Electron Multiplier back on after safe vacuum conditions are achieved.

**NOTE:** **Flex Trip Action** can turn the Emission or Electron Multiplier, or both, back on during a process that cycles between base vacuum and higher pressures.

**Flex Trip Mode**

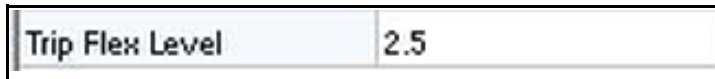
Figure 5-11 Flex trip mode



Defines the Flex Trip mode.

**Flex Trip Level**

Figure 5-12 Flex trip level



Defines the level of the Flex Trip. If **INFICON Pirani, MxG, or BxG** option is chosen as the **Signal Type**, the value entered here will be in units of Torr or millibar depending upon the units selected in **Signal Type**.

**5.5 Using Transpector XPR 3+**

Once the sensor has been conditioned, by baking it out and then keeping it under vacuum, the emission can be turned on.

**5.5.1 Leak Detection**

Using FabGuard Explorer, there is no recipe required for operating in Leak Mode. Select the Leak Mode button to default to sampling Helium (mass 4) over time. When leak checking a vacuum system that has a pressure of  $1 \times 10^{-5}$  Torr or lower, the High Pressure Electron Multiplier should be used. The HPEM voltage that is necessary is based on the level of the leak that you are searching for. Adjust the HPEM voltage so that the Helium (Mass 4) signal can be observed, but do not exceed an intensity of 1E-7 amps. Refer to the FabGuard Explorer Operating Manual for complete information on Leak Detection Mode.

### 5.5.2 Recipe Generation

Using Transpector XPR 3+ for background monitoring or process monitoring is accomplished by creating and running a recipe. Refer to the FabGuard Explorer operating manual for complete information on Recipe Generation.

### 5.5.3 Mass Scale Tuning

Another part of preventive maintenance is checking the functional operation of Transpector XPR 3+. This includes the mass position and mass resolution of the instrument.

Refer to [section 7.6, Mass Calibration](#), on page 7-9 for information on tuning Transpector XPR 3+.

### 5.5.4 Transpector XPR 3+ Filament

The Transpector XPR 3+ filaments should last a minimum of 4000 hours when following these Best Known Methods. It is strongly recommended that the filaments be replaced after 4000 hours of operation (approximately six months of continuous operation).



#### **CAUTION**

**If the filaments are not replaced and are allowed to burn out, coating from the filament could contaminate the ion source plate and create electrical shorts preventing operation with a new set of filaments.**

The yttria-coated filament (part number 914-022-G2) is field replaceable. Replacement instructions are included in the filament kit and are also found at **Section 6.5.3** in this manual.

### 5.5.5 High Pressure Electron Multiplier

Since the HPEM is used at background and process pressure, the EM hours will mirror those of the emission hours. The HPEM gain may degrade over time and it is recommended to replace the EM when the EM voltage can no longer be adjusted to achieve a 300 gain. It is expected that the HPEM will last greater than 1 year, when used continuously.

**CAUTION**

---

**The HPEM degrades from monitoring high ion currents.  
Avoid measuring ion currents above 1E-7 Amps while  
operating with the HPEM on.**

---

---

## Chapter 6

# Transpector XPR 3+ Low Pressure EM

---

### 6.1 Introduction

This chapter provides information concerning the Transpector XPR 3+ Low Pressure EM option. Information concerning the software is located in the *FabGuard Explorer Operating Manual* or the FabGuard help files, included with your Transpector XPR 3+ Gas Analysis System.

### 6.2 Transpector XPR 3+ Filament Caution

Sampling atmosphere or oxygen above  $1 \times 10^{-4}$  Torr using Transpector XPR 3+ is not recommended. To obtain maximum useful life from the Transpector XPR 3+ filaments observe the following caution.



---

#### CAUTION

**Attempting to turn on the emission above 10 mTorr (20 mTorr with Pirani Interlock option) may result in premature failure of filaments.**

**Utilize the Pirani Interlock option or other measures to operate the Transpector XPR 3+ within a safe pressure range.**

---

Failure to observe this caution will result in premature failure of filaments. Filament replacement is not covered by warranty under these conditions.

Please read [Chapter 3, How The Instrument Works](#), before using the Transpector XPR 3+ filament and follow the recommendations in the *Transpector XPR 3+ Operating Manual, Chapter 6, Best Known Methods*.

### 6.3 Electron Multiplier Caution



---

#### CAUTION

**Operating the Electron Multiplier at a total pressure greater than  $1 \times 10^{-4}$  Torr, or with an output current greater than  $5 \times 10^{-7}$  Amps, will damage the Electron Multiplier and reduce its lifetime.**

---

## 6.4 Quick Start

To quickly put Transpector XPR 3+ Low Pressure EM Gas Analysis System to work, perform the following tasks.

- 1 Check to ensure that everything has been received.  
See [section 6.8, Supplied Items, on page 6-5](#).
- 2 Install the Hardware. See Chapter 1 Getting Started.
- 3 Install the Software. See Chapter 1 Getting Started.
- 4 Review the *Transpector XPR 3+ Operating Manual, Chapter 5, Operation*, before using Transpector XPR 3+ Low Pressure EM.

## 6.5 Purpose of the Transpector XPR 3+ Low Pressure EM Option Gas Analysis System

Transpector XPR 3+ Low Pressure EM Gas Analysis System is a quadrupole-based residual gas analyzer that operates at process pressures up to 10 mTorr (20 mTorr with the Pirani Interlock option). It has an Electron Multiplier that can operate at pressures up to  $1 \times 10^{-4}$  Torr. The miniature quadrupole sensor analyzes gases by:

- ♦ ionizing some of the gas molecules
- ♦ separating the ions by mass
- ♦ measuring the quantity of ions at each mass

The masses allow the identification of the gas molecules from which the ions were created. The magnitudes of these signals are used to determine the partial pressures (amounts) of the respective gases.

Transpector XPR 3+ is an important aid in the efficient use of a high-vacuum system, detecting leaks and contaminants. It can indicate the partial pressures of gases characteristic of processes occurring within a vacuum or other vessel, and therefore, can be used to investigate the nature of a process or to monitor process conditions.



## 6.6 General Description of Transpector XPR 3+ Low Pressure EM Option Gas Analysis System

Transpector XPR 3+ Low Pressure EM Gas Analysis System is comprised of:

### **Sensor**

The sensor, which functions only in a vacuum environment with pressures below  $1 \times 10^{-2}$  Torr ( $2 \times 10^{-2}$  Torr with Pirani Interlock option).

The sensor itself is comprised of three parts:

- ◆ ion source (ionizer)
- ◆ quadrupole mass filter
- ◆ ion detector

Transpector XPR 3+ Low Pressure EM detector includes a continuous dynode electron multiplier (CDEM) that can operate at a total pressure up to  $1 \times 10^{-4}$  Torr. The CDEM voltage range is 775 to 1,225 volts.

The sensor is mounted on an electrical feed-through flange, which is bolted to the vacuum space where the gas analysis measurements are made.

### **Electronics Module**

The electronics module controls the sensor. The electronics module and sensor are matched, sold, and operated as a set. The electronics module attaches to and is supported by the sensor.

### **Pirani Interlock (Optional)**

The optional Pirani Interlock controls sensor emission.

### **Software**

The software controls the electronics module.

## 6.7 Specifications for Transpector XPR 3+ Low Pressure EM Option Gas Analysis System

Table 6-1 details the specifications for Transpector XPR 3+ Low Pressure EM.

Table 6-1 Transpector XPR 3+ Low Pressure EM specifications

<b>Mass Range (amu)</b>	1-100
<b>Resolution (per 1993 AVS Recommended Practice)</b>	< 1 @ 10% measured at mass 4, 20, 28 and 40
<b>Mass Filter Type</b>	Quadrupole
<b>Detector Type</b>	Faraday Cup and Electron Multiplier
<b>Temperature Coefficient (as FC, 1E-4 Torr of Ar)</b>	< 1% of peak height per °C
<b>Mass Position Stability (as FC 1E-4 Torr of Ar, Constant Temperature)</b>	< 0.1 amu over 24 hours**
<b>Peak Ratio Stability (28/40) as FC</b>	Better than 2% over 24 hours
<b>Sensitivity (nominal) As FC at 40 eV / 200 µA Emission As EM at 70 eV / 400 µA</b>	≥ 4E-7 amps/Torr ≥ 8E-3 amps/Torr
<b>Minimum Detectable Partial Pressure* As FC at 40 eV / 200 µA As EM at 70 eV / 400 µA</b>	≤ 1E-9 Torr ≤ 6E-12 Torr
<b>Minimum Detectable Concentration</b>	50 ppm
<b>Maximum Operating Pressure With Pirani Interlock Option Without Pirani Interlock Linear Operation</b>	20 mTorr 10 mTorr 10 mTorr
<b>Maximum Sensor Operating Temperature</b>	150 °C
<b>Maximum Bakeout Temperature (Electronics Removed)</b>	200 °C
<b>Operating Temperature (Ambient)</b>	5-50 °C
<b>Power Input</b>	20-30 V(dc), 24 V(dc) Typical, Latching, 4-pin Din connector, internally isolated from system ground
<b>Ethernet Communication Interface</b>	Standard: Cat5e Ethernet Cable Connection

Table 6-1 Transpector XPR 3+ Low Pressure EM specifications (continued)

<b>Relay Outputs</b>	1 relay, 24 V at 0.5 amps
<b>Inputs</b>	1 Analog Input, 2 Digital Inputs
<p><b>NOTE:</b> All specifications after a 30 minute warm up.</p> <p>* MDPP (Minimum Detectable Partial Pressure) is calculated as the standard deviation of the noise (minimum detectable signal) divided by the sensitivity of the Sensor measured at a four-second dwell time.</p> <p>** Peak Lock active for 24-hour mass position stability.</p>	

## 6.8 Supplied Items

See Chapter 12, Supplied Items for a what should be included with the Transpector XPR 3+ system.

## 6.9 XPR 3+ Low Pressure EM Installation

See Chapter 1 Getting Started for instructions on how to install the Transpector XPR 3+ system.

## 6.10 XPR 3+ Low Pressure EM Operation

For proper operation of the Transpector XPR 3+ system please refer to Chapter 5 Transpector XPR 3+ Operation.



### CAUTION

---

**Transpector XPR 3+ Low Pressure EM Gas Analysis System has an Electron Multiplier that can operate at pressures up to  $1 \times 10^{-4}$  Torr.**

---

---

## Chapter 7

# Maintenance

---

### 7.1 Introduction

The Transpector XPR 3+ sensor is subject to aging in normal use and some of its components will eventually require repair or replacement.

The Transpector XPR 3+ electronics module does not normally require repair or maintenance.



#### **WARNING - Risk Of Electric Shock**

---

**Opening the Transpector XPR 3+ Electronic Module should only be done by qualified service personnel. There are no user-serviceable parts inside the Electronic Module.**

---

INFICON provides complete maintenance service for both sensors and Electronic Modules. Refer to [section 1.3, How To Contact Customer Support, on page 1-2](#).

### 7.2 Safety Considerations

If Transpector XPR 3+ is used in a manner not specified by INFICON, protection provided by the equipment may be impaired.

#### 7.2.1 Toxic Material

The Transpector XPR 3+ sensor does not contain any toxic material. However, if the Transpector XPR 3+ sensor is used in an application wherein toxic material is used or generated, residue of the toxic material will likely be present on the surface of the Transpector XPR 3+ sensor. Appropriate safety precautions must be taken when handling contaminated sensors in order to assure safety of maintenance personnel.

To return the sensor to INFICON for repair, refer to [section 1.3.1, Returning Transpector XPR 3+ to INFICON, on page 1-3](#).

The Transpector XPR 3+ electronics module is RoHS compliant.

#### 7.2.2 Radiation

Transpector XPR 3+ Gas Analysis systems are not known to produce harmful radiation.

### 7.2.3 Electrical Voltages

Transpector XPR 3+ does not present electrical hazards when enclosed and grounded according to the specifications given in the installation instructions.



#### **WARNING - Risk Of Electric Shock**

---

If the Transpector XPR 3+ electronics module is operated while open, hazardous electrical voltages may be present. Such operation should not be attempted except by qualified service personnel.

---

### 7.3 General Instructions For All Repair Procedures



#### **CAUTION**

---

Perform any servicing in a clean, well illuminated area.

Wear clean, nylon, lint free lab gloves or finger cots.

Do not touch the vacuum side of the sensor with unprotected fingers.

Use clean tools.

---

## 7.4 Maintenance Procedures

### 7.4.1 Bakeout of Quadrupole

If the symptoms in [section 8.2, Symptom-Cause-Remedy Chart, on page 8-1](#), suggest that the sensor is contaminated, try first to restore normal performance by baking the sensor under a high vacuum—at least  $1 \times 10^{-5}$  Torr ( $1.333 \times 10^{-5}$  mbar) [ $1.333 \times 10^{-3}$  Pa]—for several hours, preferably overnight. [Table 7-1](#) represents the maximum bakeout temperatures.

If baking the sensor doesn't increase the sensor performance, it may be necessary to perform the tasks described in [section 7.5.3, Filament Kit Replacement, on page 7-5](#).

If the procedures explained above do not solve the problem, contact INFICON. Refer to [section 1.3, How To Contact Customer Support, on page 1-2](#).

Table 7-1 Maximum bakeout temperatures

		While Operating	With Electronics Removed
Transpector XPR 3+			
Electron Multiplier	EM Mode	150°C	200°C
Faraday Cup	FC Mode	150°C	200°C
Combination			



#### CAUTION

**When heating the sensor above 150 °C, the electronics module and the signal contact must be removed from the sensor.**

### 7.4.2 Spare Heating Jacket Part Numbers

INFICON offers several heating jackets to help in baking a sensor. These heating jackets operate at a maximum temperature of 150°C.

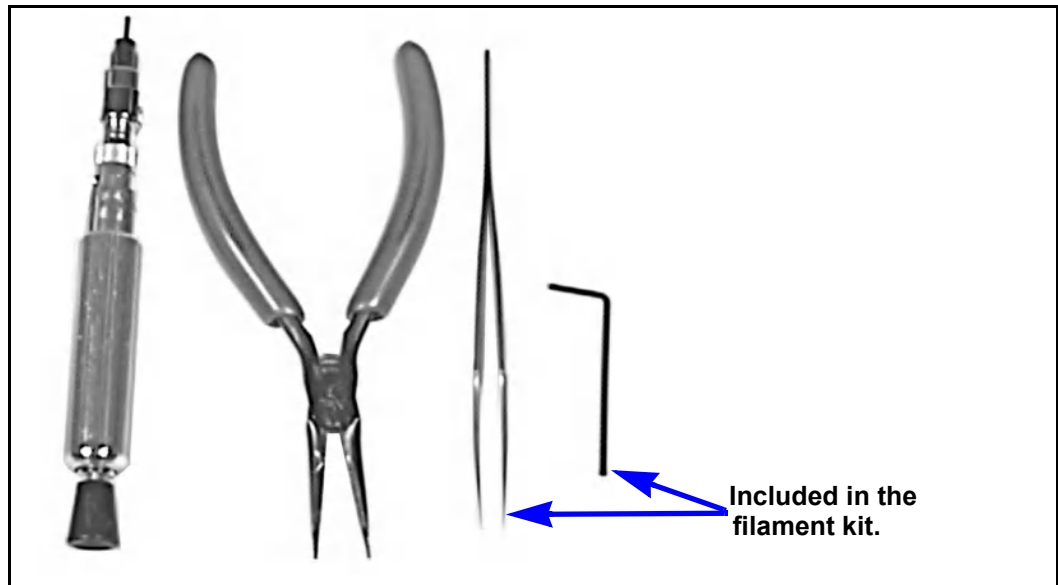
Heating jacket part numbers are shown in [Table 11-1 on page 11-1](#).

## 7.5 Repair Procedures

### 7.5.1 Tools Required

- ◆ The hand tools shown in [Figure 7-1](#).
- ◆ A DMM capable of measuring 30M $\Omega$  or above.

Figure 7-1 Tools required

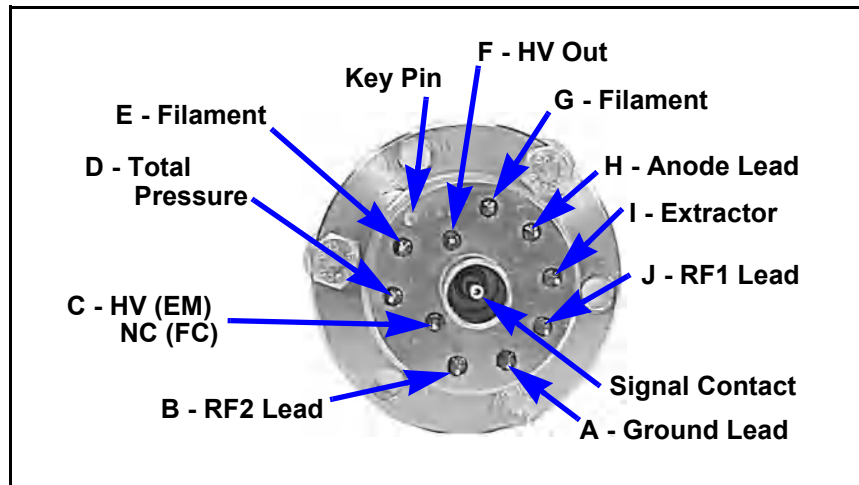


## 7.5.2 How to Determine if a Filament Kit Replacement is Required

Follow these steps to determine if a filament replacement is required.

- 1 Measure the filament resistance. This can be accomplished while the sensor is under vacuum by measuring the resistance between pins **G** and **E**. (See [Figure 7-2](#).) A failed filament will measure open. An intact filament assembly will read approximately  $0.5 \Omega$

Figure 7-2 Transpector XPR 3+ sensor pin location



**NOTE:** Although the following measurements may measure below  $30 M\Omega$  with the filament assembly and ceramic shield in place, they must be above  $30 M\Omega$  when measured with the filament assembly and ceramic shield removed.

- 2 Measure the resistance of each of the pins with respect to ground (pin **A**). These measurements should be above  $30M\Omega$ .
- 3 Measure the resistance of each of the pins with respect to each other. All of these measurements should also be above  $30M\Omega$ , with the exception of across the filament if the filament has not failed.

## 7.5.3 Filament Kit Replacement

A filament replacement kit can be purchased from INFICON. This kit contains a new filament assembly mounted on a shipping fixture and a small Allen wrench. Perform the following steps to replace the filament.

**NOTE:** Refer to [section 7.5.1, Tools Required](#), on [page 7-4](#), before continuing.



**CAUTION**

Do not, under any circumstances, remove the quadrupole assembly from the ion source base plate. Doing so will require factory realignment.

Use finger cots or talc free latex gloves when changing the filament assembly. Do not use nylon gloves when handling a Transpector XPR 3+ Sensor.

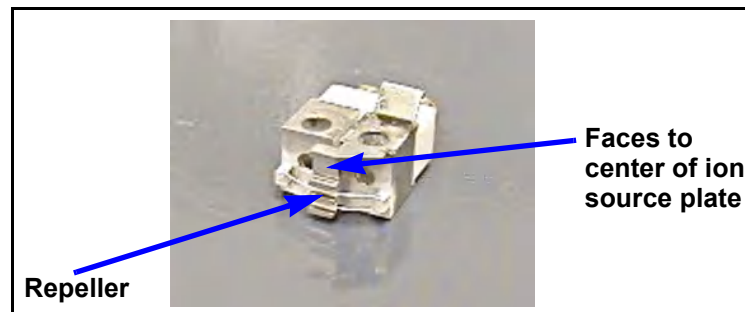
The Total Pressure circuit must be recalibrated after changing the filament.

**CAUTION**

Neither the filament assembly or the ion source can be cleaned. When dirty, they must be replaced.

- 1 Install the filament so that the face of the repeller is parallel to the face of the anode and the filament is approximately centered to the two mounting screws (per steps 2 and 3 below). See [Figure 7-3](#).

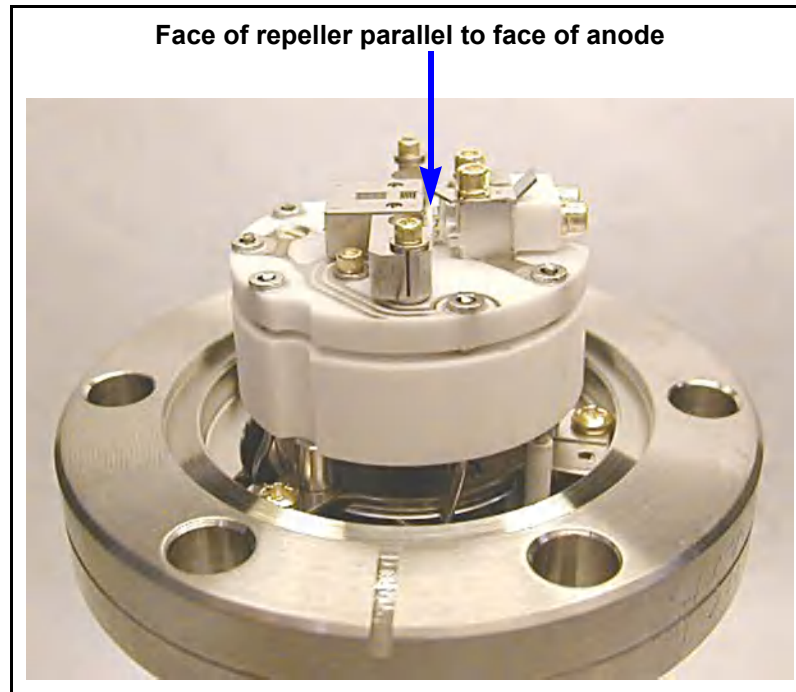
Figure 7-3 Filament assembly



- 2 Align the holes in the filament blocks with those on the base plate.
- 3 Place the lock washers on the screws, and then insert the screws through the filament assembly and into the holes in the ion source base plate. Alternately tighten the screws until the screw heads just touch the lock washers. See [Figure 7-4](#).

**NOTE:** Both screws must have lock washers to maintain mechanical connection and therefore electrical connection from the traces to the filament assembly.

Figure 7-4 Filament in place on sensor



- 4 While holding the short end of the hex wrench, alternately tighten the screws until the hex wrench begins to flex. Alternately use a torque-limiting screwdriver (IPN 02-389-P1 or equivalent), torque the screws to 10-12 oz In. (0.0384 Nm to 0.0461 Nm).

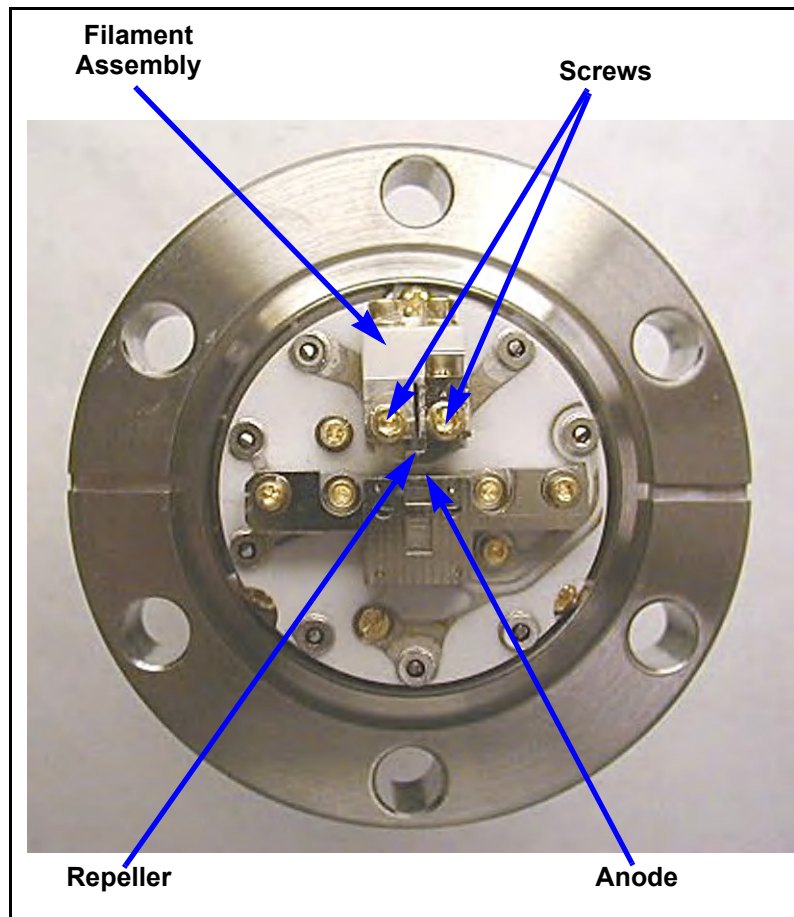
**CAUTION**

Do not touch the filament wires.

#### 7.5.4 How to Determine the Condition of the Ion Source

- 1 Remove the Transpector XPR 3+ sensor from the vacuum system.
- 2 Completely loosen the two 1-72 x 0.31 in. long gold plated cap head screws that hold the filament assembly to the ion source plate. Remove the filament assembly and screws. See [Figure 7-5](#).

Figure 7-5 Top view of the Transpector XPR 3+ sensor



- 3** Measure the resistance of each of the pins with respect to ground (refer to pin **A** in [Figure 7-2](#)). These measurements should be above  $30\text{M}\Omega$ .
- 4** Measure the resistance of each of the pins with respect to each other. All of these measurements should also be above  $30\text{M}\Omega$ .
- ◆ If any of the measurements in steps 3 and 4 are less than  $30\text{M}\Omega$  the ion source is contaminated and requires cleaning or replacement before the new filament is installed. Contact the nearest INFICON Service Center for assistance with returning the unit to the factory for repair. Refer to [section 1.3, How To Contact Customer Support](#), on page 1-2.

If the resistance measurements in steps 3 and 4 above are greater than  $30\text{M}\Omega$  refer to [section 7.5.3, Filament Kit Replacement](#).

## 7.6 Mass Calibration

### 7.6.1 Mass Alignment

Transpector XPR 3+ is tuned such that it generates a known RF/DC ratio that allows one mass to exit the quadrupole at a time. When tuning the mass scale of Transpector XPR 3+, the RF/DC ratio is fine tuned to each tune mass.

Another part of preventive maintenance is checking the functional operation of Transpector XPR 3+. This includes the mass position and mass resolution of the instrument. While this mass scale tuning is accomplished in a similar fashion to any other Transpector, Transpector XPR 3+ does have some slightly different values for peak width adjustment.

For more detailed information regarding mass tuning using FabGuard, please refer to the FabGuard Explorer operating manual

#### 7.6.1.1 Factory Tuning

The gases that are used for factory tuning of these masses are:

- ◆ Hydrogen (mass 1 and 2)
- ◆ Helium (mass 4)
- ◆ Nitrogen (mass 28)
- ◆ Argon (mass 40)
- ◆ Krypton (mass 86)

#### 7.6.1.2 Mass Scale Tuning at Base Pressure

Mass scale tuning can be done at base pressure using the background peaks of water vapor (18 AMU) and nitrogen (28 AMU). The following procedure should be used to check peak location and peak widths at mass 18 and mass 28 and to make adjustments as needed.



#### **CAUTION**

**Do not attempt to remove masses 1, 2, 4, or 86 AMU from the Tune Table or adjust the resolution at these masses.**

### 7.6.1.3 Mass Scale Tuning with Process Gas

For mass scale tuning at process pressures, the following procedure should be used to adjust the argon (40 AMU) and/or nitrogen (28 AMU). This tuning procedure can be used for argon, argon-nitrogen, or argon-oxygen processes.

**NOTE:** For this mass scale tuning procedure, the Tune Mass Table should be the default Tune list, which is masses 1, 2, 4, 28, 40, and 86. If this list is not present when the Tune window is opened, modify the Tune Mass Table as necessary to show only masses 1, 2, 4, 28, 40, and 86.



#### **CAUTION**

**Do not attempt to remove masses 1, 2, 4, or 86 AMU from the Tune Table or adjust the resolution at these masses.**

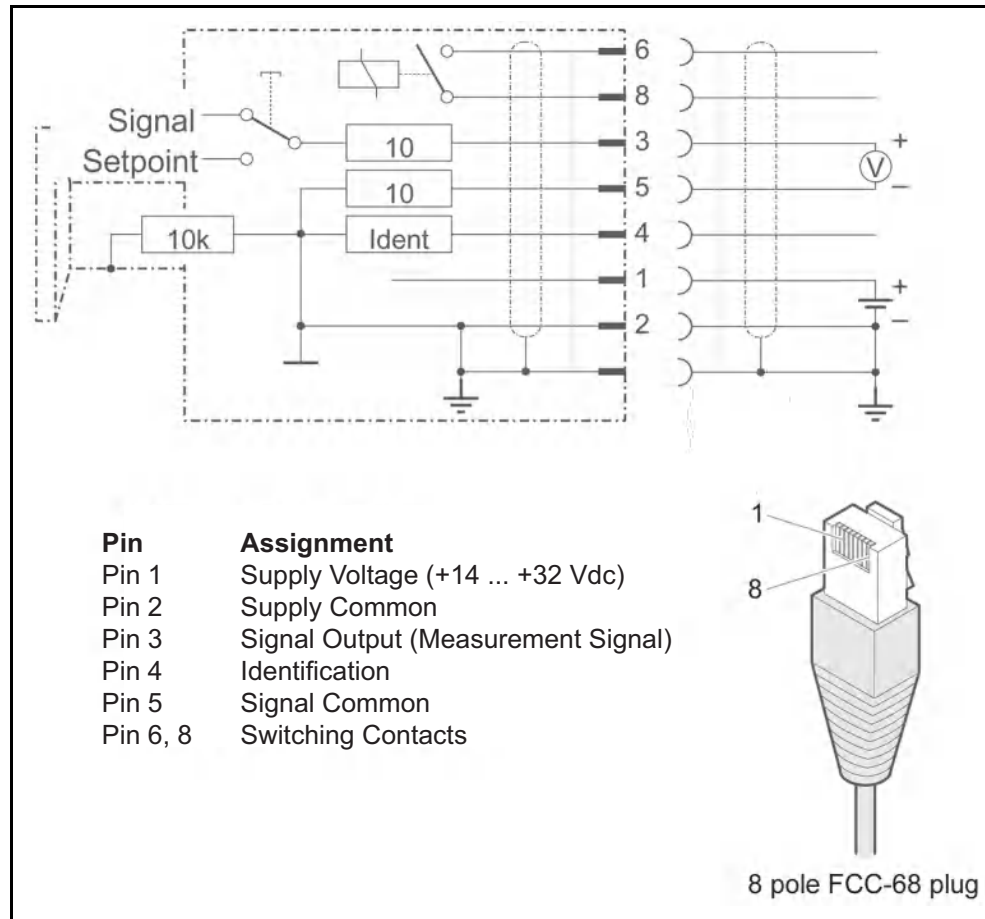
## 7.7 Pirani Interlock Adjustment Procedures

Follow these procedures for adjusting the Pirani Interlock on XPR 3+.

### 7.7.1 INFICON PSG500 Adjustment Instructions

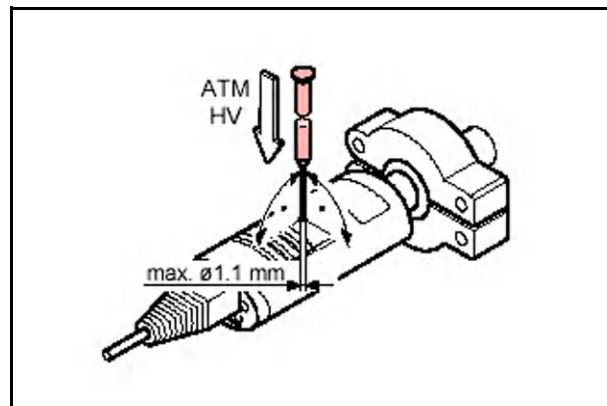
- 1 Mount the Pirani gauge on the vacuum system.
- 2 Apply power to the gauge, 24 V(dc). See [Figure 7-6](#).

Figure 7-6 PSG500 electrical connections



- 3 Allow the Pirani gauge to warm-up for a minimum of 10 minutes.
- 4 While at atmosphere (air or nitrogen), press the button on the back of the gauge (see Figure 7-7) with the supplied tool to make the ATM (atmosphere) adjustment. The gauge is automatically adjusted to 750 Torr (1000 mbar) [99,991.78 Pa], which is a Pirani voltage of 10 V(dc) ( $\pm 0.1V$ ).

Figure 7-7 PSG500 adjustment button



- 5** Evacuate the vacuum system to a pressure of less than  $7.5 \times 10^{-6}$  Torr ( $1 \times 10^{-5}$  mbar) [ $1 \times 10^{-3}$  Pa] and wait at least 2 minutes.
- 6** While at high vacuum, press the button on the back of the gauge to adjust the HV (high vacuum) setting. The gauge is automatically set to 1.0 V(dc) by default. Press the button for > 5 seconds until the voltage increases to  $1.9 \pm 0.1$  V(dc).
- 7** Vent the system to atmosphere (air or nitrogen) and verify that the Pirani voltage is  $10.0 \pm 0.1$  V(dc). Repeat the ATM adjustment if the setting at atmosphere has changed.
- 8** Evacuate the system to a pressure of less than  $7.5 \times 10^{-6}$  Torr ( $1 \times 10^{-5}$  mbar) [ $1 \times 10^{-3}$  Pa] and wait at least 2 minutes.
- 9** Verify that the Pirani voltage at high vacuum is still  $1.9 \pm 0.1$  V(dc). If the Pirani voltage has changed, repeat the HV adjustment to read  $1.9 \pm 0.1$  V(dc).
- 10** If a readjustment of the HV setting was done in step 9, repeat steps 7-10 of this procedure until valid readings are obtained at atmosphere and high vacuum.

## Chapter 8

### Diagnosing Problems

#### 8.1 Introduction

If you are experiencing trouble with your Transpector XPR 3+, first look at [Table 8-1](#) and see if your problem is listed there. If not, contact INFICON (refer to [section 1.3, How To Contact Customer Support, on page 1-2](#)).

#### 8.2 Symptom-Cause-Remedy Chart

Make sure that the insulation on all cables is intact and there is no damage on the insulating material before using [Table 8-1](#).

Table 8-1 Symptom—Cause—Remedy chart

SYMPTOM	CAUSE	REMEDY
<b>Power LED does not turn on</b>	+24 V external power supply	Check input AC line voltage to external power supply.
		Check +24 V input, verify input between 20 - 30 V.
		Replace power supply.
	Electronics failure	Return to INFICON for repair.
<b>No communication to HOST computer</b>	Sensor IP address not compatible with network	Refer to <a href="#">Chapter 2, Connecting Transpector XPR 3+</a> .
	Transpector communications port (port 80) is not open on the host computer	Either open port 80 on the host computer or change the communications port of Transpector XPR 3+.
	Cable connections	Make sure cables are connected to proper connectors.
	Host computer Ethernet card malfunctioning	Replace Ethernet Card on host computer.



Table 8-1 Symptom—Cause—Remedy chart (continued)

SYMPTOM	CAUSE	REMEDY
<b>EMISSION error</b> (Cold Start, Warm Start)	Defective sensor filament open, shorted	Check sensor with OHM meter.
		Replace sensor or filament.
	Electronics failure	Return to INFICON for repair.
	Insufficient vacuum	Verify pressure is less than 2E-2 Torr.
	Sensor operating voltages incorrect	Verify correct settings Contact INFICON for assistance.
	Transpector XPR 3+ electronics box not fully engaged on sensor	Make sure that the Transpector XPR 3+ electronics module is pushed all the way on sensor.
<b>ANODE error</b>	Defective sensor, anode shorted	Check sensor with OHM meter for shorts. See sensor pin-out diagram.
		Fix or replace sensor.
	Electronics failure	Return to INFICON for repair.
<b>RF error</b>	Defective sensor, RF leads open RF/DC card fault	Fix or replace sensor.
	Electronics failure	Return to INFICON for repair.
<b>Electron Multiplier error</b>	Defective sensor, EM shorted	Check sensor with Ohm meter. See sensor pin-out diagram.
		Fix or replace sensor.
	Electronics failure	Return to INFICON for repair.

Table 8-1 Symptom—Cause—Remedy chart (continued)

SYMPTOM	CAUSE	REMEDY
<b>Temperature error</b>	Transpector XPR 3+ internal ambient temp >70°C	Verify unit is installed properly, ambient temp <50°C.
		Verify that there are no heat sources in local proximity.
		Verify that internal fan is running.
	Electronics failure	Return to INFICON for repair.
<b>Overpressure</b>	Total pressure plate current exceeded trip threshold	Reduce pressure.
	Total pressure plate is contaminated	Return to INFICON for repair.
<b>Electrometer Error</b>	Excessive current (>2E-6 Amps)	Reduce pressure.
		Reduce EM voltage.
	Electronics failure	Return to INFICON for repair.
<b>Mass Filter Error</b>	Bad tune file	Retune RGA.
	Contaminated quadrupole	Return to INFICON for repair.
<b>Ion Source Error</b>	Incorrect Ion source settings	Load original configuration file.
	Ion source contaminated	Return to INFICON for repair.
<b>Detector Error</b>	EM voltage set too high	Reduce EM voltage.
	Detector not working correctly	Replace EM detector.
<b>DSP Communications Error</b>	Incorrect DSP response detected	Reset electronics box.
		Return electronics box to INFICON for repair.
<b>DEC Communications Error</b>	Incorrect DEC response detected	Reset electronics box.
		Return electronics box to INFICON for repair.

Table 8-1 Symptom—Cause—Remedy chart (continued)

SYMPTOM	CAUSE	REMEDY
<b>Peakfind Error</b>	No peak at target mass	Upload original configuration file.
		Return electronics box to INFICON for repair.
<b>Filament Potential Error</b>	Insufficient vacuum	Verify pressure is less than 2E-2 Torr.
	Filament broken	Verify integrity of filament.
	Filament shorted	Verify that filament is not shorted to ground.
<b>Filament Current Error</b>	Insufficient vacuum	Verify pressure is less than 2E-2 Torr.
	Filament broken	Verify integrity of filament.
	Filament shorted	Verify that filament is not shorted to ground.
<b>Focus Error</b>	Unable to start or maintain Focus voltage	Reset electronics box.
		Return electronics box to INFICON for repair.
<b>No spectra</b>	Emission is OFF	Turn Emission ON.
	EM is ON, when operating	Turn EM OFF.
	Contaminated sensor	Degas, or service sensor.
		Replace sensor.
	Electronics failure	Return to INFICON for repair.
	Pressure too low for FC	Use EM detector.
	EM voltage too low	Increase voltage.
	Transpector XPR 3+ electronics box not fully engaged on sensor	Push Transpector XPR 3+ electronics module completely onto sensor.
Mass calibration	Adjust mass calibration.	

Table 8-1 Symptom—Cause—Remedy chart (continued)

SYMPTOM	CAUSE	REMEDY
<b>Poor sensitivity</b>	Sensor contaminated	Degas sensor.
		Bake-out sensor.
		Service sensor.
	System pressure too low	Increase sample pressure, if possible.
	Mass calibration (resolution)	Adjust Mass Calibration, increase peak width.
	Sensor operating parameters set wrong	Check settings of: electron energy, ion energy, focus emission current.
	Improper calibration	Ensure that the total pressure gauge used for sensitivity calibration was properly calibrated.
	Electronics failure	Return to INFICON for repair.
<b>Poor peak shape</b>	Sensor contaminated	Bake-out sensor.
		Replace sensor.
		Degas sensor.
	System pressure too high	Verify pressure less than 2E-2 Torr for Transpector XPR 3+.
	Mass calibration required	Perform mass calibration.
	Electronics failure	Return to INFICON for repair.

Table 8-1 Symptom—Cause—Remedy chart (continued)

SYMPTOM	CAUSE	REMEDY
<b>High noise level</b>	System grounding	Verify that vacuum system is grounded.
	Electronics failure	Return to INFICON for repair.
	Transpector XPR 3+ electronics box not mounted properly on sensor	Push Transpector XPR 3+ electronics box all the way on to the sensor.
	EM defective	Replace sensor or Return to INFICON for repair.
	Scan speed too fast for gain setting	Increase dwell time.

### 8.3 Communication Problems

To correct communication problems, check the following:

- ♦ Is the Ethernet cable connected to Transpector XPR 3+ and the host computer (either directly or through a router/switch)?
- ♦ Does the Transpector XPR 3+ IP address have the same network prefix as the host computer?
- ♦ Is Port 80 open on the host computer?
- ♦ Is there an IP address conflict between Transpector XPR 3+ and another network device?
- ♦ Refer to [Chapter 2, Connecting Transpector XPR 3+](#) for more information on communications problems.

## **Chapter 9**

### **Bibliography**

---

For further information on partial pressure analyzers, see *Partial Pressure Analyzers and Analysis*, M. J. Drinkwine and D. Lichtman, American Vacuum Society Monograph Series, or *A User's Guide to Vacuum Technology*, J. F. O'Hanlon, John Wiley and Sons (1989). The latter book also contains a wealth of information on related topics including gas flow, pressure gauges, pumps, materials, and the design of vacuum systems.

---

## Chapter 10

### Glossary

---

**Anode**

The anode is the structure in the ion source in which ions are created by electron impact. It can be formed from a mesh, such as in the open ion source, or from a solid tube, such as in the closed ion source. Its electrical potential is positive with respect to the filament, focus lens, total pressure plate, pole zero, exit aperture and Faraday cup.

**Appearance Potential**

The minimum electron energy required to produce, by electron bombardment, a given ion in its lowest energy state.

**Atomic Mass Unit (AMU)**

An atomic mass unit is a unit of measurement for the mass of a molecule or ion. It is based on the definition that the mass of an atom of the carbon-12 isotope is exactly 12.

**Background**

The background is the residual atmosphere in a vacuum apparatus when no gases are being deliberately introduced.

**Bakeout**

A bakeout is the process of heating a vacuum chamber above the ambient temperature in order to accelerate the desorption of species such as water vapor and hydrocarbons which are adsorbed onto the inner surfaces of the vacuum chamber.

**Center Voltage**

The center voltage is the DC potential to which the quadrupole rod RF and differential DC potentials are referenced.

**Closed Ion Source (CIS)**

The closed ion source is an ion source in which the pressure in the ionization region is higher than in the rest of the analyzer sensor. This is usually accomplished by fabricating the anode from a solid walled tube instead of an open mesh. This type of source is usually employed to measure trace contaminant levels in a process gas.

**Conductance**

The conductance of a gas flow channel is the ratio of the gas quantity flowing through the channel to the pressure drop across that channel.

**Cracking Pattern**

See **Fragmentation Pattern**.

**Detection Factor**

The detection factor is the ratio of the detected signal for a given ion current from a certain substance to the detected signal for the same ion current of nitrogen ions as measured at mass 28. For Faraday cup detectors, the detection factor is usually 1. For electron multiplier detectors, this factor depends on the mass and chemical nature of the ion.

**Detector**

The detector is that part of the mass spectrometer sensor which converts a beam of ions into an electrical signal.

**Doubly Charged Ion**

For positive ions, a doubly charged ion is a parent or fragment ion where two electrons have been removed.

**Electron Energy**

The electron energy is the kinetic energy of the ionizing electrons in an electron bombardment ion source and is typically measured in units of electron volts (eV). The electron energy is approximately equal to the difference between the bias voltage on the filament and the anode potential, times the electron charge.

**Electron Multiplier**

An electron multiplier is a *in situ* amplifier which is used to increase the sensitivity of a mass spectrometer. When a high voltage is applied to an electron multiplier, positive ions are accelerated into the multiplier, causing the release of a large number of electrons per incident ion at the output.

**Emission Current**

The emission current is the current of electrons leaving the surface of a heated filament.

**Exit Aperture (Quadrupole)**

The exit aperture is a focus lens at the ion exit (detector) end of a quadrupole mass spectrometer. This lens is often biased by a potential that is negative with respect to the quadrupole center voltage such that ions are extracted from the exit end of the quadrupole and focused into the detector.

**Extractor**

See **Focus Lens**.

**Faraday Cup**

The Faraday Cup is a detector for ions and/or electrons consisting of a cup shaped, conductive electrode.

**Filament**

The filament is a fine wire or ribbon, which, when heated by means of electrical current, emits electrons. The filament typically made of iridium with a thorium or yttrium oxide coating, or of tungsten or a tungsten alloy.



**Focus Lens**

The focus lens is a conductive aperture located next to, and usually biased negatively with respect to, the anode. Its purpose is to draw the ions out of the anode, form them into a beam, and focus them into the next lens element.

**Fragment Ion**

A fragment ion is an ion with fewer atoms than the parent gas molecule from which the ion is produced. The mass of the fragment ion is always less than that of the parent ion.

**Fragmentation Factor**

The fragmentation factor is the fraction of the total ions produced from a specified substance which have a given mass. The sum of the fragmentation factors for all of the ions produced from a specified substance is equal to one.

**Fragmentation Pattern**

The fragmentation pattern is the pattern of ion masses and intensities produced by electron bombardment of a specified gas species as transmitted by the mass filter, detected and recorded.

**Gain (Electron Multiplier)**

The gain of an electron multiplier is the ratio of incident ion current to electron current output. The gain of the multiplier is a strong function of the bias potential applied across it.

**Ion**

An ion is a molecule or atom which has either lost or added one or more electrons. Those molecules which have lost electrons are positive ions. Those molecules which have added electrons are negative ions.

**Ion Current**

An ion current is the rate of flow of electrical charge associated with the flow of ions.

**Ion Energy**

The ion energy is the kinetic energy associated with a beam of ions. It is equal to the potential difference across which the ion beam is accelerated (or decelerated) times the charge on the ion, and is typically measured in electron volts (eV). Specifically, in a quadrupole mass spectrometer, it is the kinetic energy, along the axis, of the ions as they pass through the mass filter. The ion energy is approximately equal to the anode potential minus the quadrupole center voltage time the ionic charge.

**Ion Source**

The ion source is that part of a mass spectrometer in which neutral gas molecules or atoms are ionized by electron bombardment.

**Ionization Probability**

The ionization probability for a chemical substance is the ratio of the total ion current (at all masses) produced from a given partial pressure of that substance, to the total ion current produced from nitrogen at the same partial pressure.

**Isotope**

The atom is composed of nucleus protons and neutrons surrounded by an electron cloud. The chemical properties of an element are determined by the number and arrangement of electrons (with -1 charge) in an atom. The number of electrons in a neutral atom in turn depends on the number of protons (with +1 charge) within the nucleus of that atom. Atomic nuclei also contain neutrons which, being uncharged, do not affect the chemistry of an element. Protons and neutrons have approximately the same mass, which is approximately 1,800 times the mass of an electron. All atoms of a given element have the same number of protons but not necessarily the same number of neutrons. Atoms of the same element which have a different number of neutrons are called isotopes. See also **Natural Abundance**.

**Linearity**

Linearity is the mathematical relationship between an ion current and the total or partial pressure giving rise to that current. A mass spectrometer is said to have good linearity when the ion current is proportional to the pressure over a specified pressure range within a specified tolerance. Typically (but not always), the ion current will be linear with pressure at the low end of an instrument's pressure range. At some pressure near the high pressure end of an instrument's range, the ion current will be less than proportional to the pressure.

**Mass to Charge Ratio**

The mass to charge ratio is ratio of the mass of an ion to its charge, usually expressed in atomic mass units per unit electron charge.

**Mass Filter**

The mass filter is that part of the mass spectrometer which separates a beam of ions by their mass to charge ratios.

**Mass Spectrometer**

A mass spectrometer is an instrument which ionizes a gas sample, separates the resulting beam of ions by mass to charge ratio, and detects the filtered ions as an electrical signal.

**Mass Spectrum**

A mass spectrum is a record of ion current as a function of mass to charge ratio obtained with a mass spectrometer. The spectrum can be presented as a graph with mass to charge ratio on the X-axis and ion current on the Y-axis, or as a tabular listing of ion currents and the associated mass to charge ratios.

**Material Factor**

The material factor for a chemical substance is that part of the proportionality constant between the partial pressure of that substance and the resulting mass filtered ion current which depends on the chemical nature of that substance but not the particular instrument used for that measurement. The material factor is a function of the ionization probability and fragmentation factor for the specified substance.

**Mean-Free-Path**

The mean-free-path is the average distance an ion, electron, atom, or molecule can travel before colliding with an ambient gas molecule. The mean free path is inversely proportional to the pressure.

**Molecular Flow**

Molecular flow is that motion of gas molecules wherein the collisional mean free path is greater than the critical dimension of a flow constraining element such as an orifice of tube diameter. The gas flow characteristics are dominated by collisions between the gas molecules and the appropriate surfaces of the vacuum system.

**Natural Abundance**

The natural abundance of an isotope is the average percentage of all atoms of a given element which have the same number of neutrons. For example, 99.985% of all naturally occurring hydrogen atoms have no neutrons, giving an atomic mass of approximately 1, while 0.015% have one neutron, giving an atomic mass of approximately 2. There is a third isotope of hydrogen which contains two neutrons, giving an atomic mass of 3, but this isotope is unstable with such a short radioactive half life that it is not normally naturally occurring in any significant quantity on earth.

There are occasions when an observed isotopic abundance will not reflect the natural abundance. For instance, in semiconductor processing tools known as ion implanters, it is not unusual for the  $\text{BF}_3$  boron dopant source to be isotopically enriched to 99%+ of the boron-11 isotope (instead of the naturally occurring 80.22%).

**Open Ion Source (OIS)**

An open ion source is an ion source constructed with an open grid structure with high conductance between the ionization region and the vacuum region surrounding it. Residual gas analyzers are typically equipped with this type of ion source.

**Outgassing**

Outgassing is the evolution of gas which was dissolved in or adsorbed on solid surfaces inside a vacuum chamber.

**Parent Ion**

A parent ion is an ion made by removing a single electron from the original, or parent, gas molecule, and therefore has the same mass.

**Partial Pressure**

The partial pressure is the pressure of a specific chemical component of a gas mixture. The sum of all the partial pressures is the total pressure.

**Pole Zero**

See **Center Voltage**.

**Quadrupole**

A quadrupole is a mass filter consisting of four parallel electrodes or poles (hence quadrupole) arranged in a square array. Opposite poles are connected together electrically such that an electric field of hyperbolic geometry is produced. The potentials applied to these poles are a superposition of variable DC and RF voltages, generally of fixed RF frequency.

**Repeller (Electron)**

The electron repeller is an electrode located on the opposite side of the filament than the anode. The repeller is usually biased at the same potential as the negative side of the filament, or a more negative potential.

**Residual Gas Analyzer**

A residual gas analyzer is an instrument which is used to determine the quantities and chemical nature of gases present in a vacuum system. The instrument is typically a mass spectrometer equipped with an open ion source.

**Resolution**

Resolution is the ability of a mass filter to select between nearby masses. It is typically measured as the mass of the peak divided by the width of a given mass peak at 10% or 50% of the peak maximum intensity.

**Secondary Electron**

A secondary electron is an electron emitted from a surface when that surface is struck by a sufficiently energetic ion, electron, neutral molecule or photon.

**Sensitivity**

The sensitivity of a mass spectrometer is the ratio of ion current at a specified mass from a specified gas to the partial pressure of that gas, suitably corrected for background. The specified gas is typically nitrogen, measured at 28 AMU, although argon at 40 AMU is sometimes used instead, depending on the instrument.

**Total Pressure**

The total pressure is the force per unit area exerted by a gas on the walls of its container. It is equal to the sum of all the partial pressures of the different chemical species which comprise that gas.

**Total Pressure Plate**

The total pressure plate, or collector, is an electrode in the ion source on which at least a part of the ion beam impinges. The current striking this plate is a function of the total pressure in the ion source.

**Transition Flow**

Transition flow is that motion of gas molecules wherein the collisional mean free path is approximately the same as the critical dimension of a flow constraining element such as an orifice of tube diameter.

**Transmission Factor**

The transmission factor is the ratio of ion current detected at the exit end of the mass filter (set to transmit a given mass) to the current of ions of the same mass entering the filter from the ion source. Typically, the transmission factor for nitrogen ions at 28 AMU is set equal to 1. The transmission factor at other masses is given relative to that for nitrogen.

**Viscous Flow**

Viscous flow is that motion of gas molecules wherein the collisional mean free path is less than the critical dimension of a flow constraining element such as an orifice of tube diameter. The gas flow characteristics are dominated by collisions between gas molecules.

**Zero Blast**

Zero blast is the ion current which is not mass filtered and is detected when the mass spectrometer is scanning near mass zero.

# Chapter 11

## Transpector XPR 3+ Accessories and Spare Parts

### 11.1 Introduction

Transpector XPR 3+ has several accessories and spare parts for purchase. This section lists these parts and provides their INFICON part numbers.

### 11.2 Transpector XPR 3+ Accessories

*Table 11-1 Transpector XPR 3+ accessories*

<b>Part Number</b>	<b>Description</b>
600-1428-P1	Power Supply Extension Cable 4.5 m (15 ft.)
600-1429-P1	Power Supply Extension Cable 9 m (30 ft.)
961-417-G1	4-Port Ethernet Router w/ Push Button Wi-Fi
961-418-G1	8-Port Ethernet Switch
961-702-G1	Sensor Hardware Kit
914-024-G1	Angle Valve Kit, Manual (includes heater)
961-0250-G1	Angle Valve Kit, Air Operated, 24 V(dc) (includes heater)
914-410-P1	Spare Angle Valve, Manual
914-220-G1	Spare Angle Valve, Electropneumatic
914-415-P1	XPR 3+ Heater Kit 120 V(ac)
918-401-P1	Pirani Gauge
914-416-G1	Pirani Interlock Weldment
600-1449-P1	Pirani Interlock Cable

## 11.3 Transpector XPR 3+ Spare Parts

### 11.3.1 Preventative Maintenance Parts

Table 11-2 Transpector XPR 3+ preventative maintenance parts

Part Number	Description
914-022-G2	Transpector XPR 3+ Filament kit - Yttria-Coated Iridium Filaments

### 11.3.2 Replacement Spare Parts

Table 11-3 Transpector XPR 3+ replacement spare parts

Part Number	Description
961-022-G1	Spare O-ring and Nut Kit (for connection between box and sensor)
600-1190-P8	Communications Cable Ethernet 7 m
600-1190-P15	Communications Cable Ethernet 15 m
961-021-G1	Power Supply Kit: 80-250 V(ac), 1.2 m (4 ft.) US Plug
961-021-G2	Power Supply Kit: 80-250 V(ac), 1.2 m (4 ft.) US Plug, 4.57 m (15 ft.) Extension
961-021-G3	Power Supply Kit: 80-250 V(ac) 4 ft. (1.2 m) US Plug, 9.14 m (30 ft.) Extension
961-021-G4	Power Supply Kit: 80-250 V(ac) 1.2 m (4 ft.) DE Plug
961-021-G5	Power Supply Kit: 80-250 V(ac) 1.2 m (4 ft.) DE 4.57 m (15 ft.) Extension
961-021-G6	Power Supply Kit: 80-250 V(ac) 1.2 m (4 ft.) DE 30 ft. Extension
961-021-G7	Power Supply Kit: 80-250 V(ac) 1.2 m (4 ft.) UK Plug
961-021-G8	Power Supply Kit: 80-250 V(ac) 1.2 m (4 ft.) UK 4.57 m (15 ft.) Extension
961-021-G9	Power Supply Kit: 80-250 V(ac) 1.2 m (4 ft.) UK 30 ft. Extension
961-021-G10	Power Supply Kit: 80-250 V(ac) 1.2 m (4 ft.) IL Plug
961-021-G11	Power Supply Kit: 80-250 V(ac) 1.2 m (4 ft.) IL 4.57 m (15 ft.) Extension
961-021-G12	Power Supply Kit: 80-250 V(ac) 1.2 m (4 ft.) IL30 ft. Extension
914-415-P1	Spare XPR 3+ Heating Jacket (requires heater power cable)
914-407-P1	Spare Valve Heating Jacket (requires heater power cable)
961-0200-G1	Heater Power Cable Kit, US Plug

*Table 11-3 Transpector XPR 3+ replacement spare parts*

<b>Part Number</b>	<b>Description</b>
961-0200-G2	Heater Power Cable Kit, DE Plug
961-0200-G3	Heater Power Cable Kit, UK Plug
961-0200-G4	Heater Power Cable Kit, IL Plug



# Chapter 12

## Specifications

### 12.1 Introduction

The following sections detail the specifications for Transpector XPR 3+ Gas Analysis System. As a result of INFICON continuing product improvement and quality assurance programs, these specifications are subject to change without notice or obligation.

**NOTE:** All specifications are measured after a 30 minute warm-up period at constant STP unless specified.

### 12.2 Mass Range

Transpector XPR 3+	Transpector XPR 3+ Low Pressure EM
1 to 100 AMU	

### 12.3 Detector Type

Transpector XPR 3+	Transpector XPR 3+ Low Pressure EM
Microchannel Plate Electron Multiplier/ Faraday Cup	Continuous Dynode Electron Multiplier / Faraday Cup

### 12.4 Resolution

Peak Width (AMU) at 10% of peak height	
Transpector XPR 3+	Transpector XPR 3+ Low Pressure EM
1.0 AMU	

### 12.5 Temperature Coefficient

During an eight hour period, after thirty minutes of warm up	
Transpector XPR 3+	Transpector XPR 3+ LP
For FC Only—Less than 1% of peak height per °C	

## 12.6 Sensitivity

Amps/Torr [mbar] (Pa)		
	Transpector XPR 3+	Transpector XPR 3+ Low Pressure EM
FC	$4 \times 10^{-7}$ $[3 \times 10^{-7}]$ $(3 \times 10^{-5})$	$4 \times 10^{-7}$ $[3 \times 10^{-7}]$ $(3 \times 10^{-5})$

## 12.7 Minimum Detectable Partial Pressure

Torr [mbar] (Pa)		
	Transpector XPR 3+	Transpector XPR 3+ Low Pressure EM
FC	$1 \times 10^{-9}$ $[1.3 \times 10^{-9}]$ $(1.3 \times 10^{-7})$	$1 \times 10^{-9}$ $[1.3 \times 10^{-9}]$ $(1.3 \times 10^{-7})$
EM	$6 \times 10^{-12}$ $[8 \times 10^{-12}]$ $(8 \times 10^{-10})$	$6 \times 10^{-12}$ $[8 \times 10^{-12}]$ $(8 \times 10^{-10})$

## 12.8 Maximum Operating Pressure

Torr [mbar] (Pa)		
	Transpector XPR 3+	Transpector XPR 3+ Low Pressure EM
FC only	20 mTorr $[2.6 \times 10^{-2}]$ (2.6)	20 mTorr $[2.6 \times 10^{-2}]$ (2.6)
FC/EM	20 mTorr $[2.6 \times 10^{-2}]$ (2.6)	$1 \times 10^{-4}$ Torr $[1.3 \times 10^{-4}]$ $(1.3 \times 10^{-2})$

## 12.9 Maximum Sensor Operating Temperature

Degrees C		
	Transpector XPR 3+	Transpector XPR 3+ Low Pressure EM
FC/EM	150°C	150°C

### 12.10 Maximum Bakeout Temperature

Degrees C — with electronics removed	
Transpector XPR 3+	Transpector XPR 3+ Low Pressure EM
200°C	

### 12.11 Operating Temperature

Transpector XPR 3+	Transpector XPR 3+ Low Pressure EM
5 to 50°C ambient	

### 12.12 Power Input

Transpector XPR 3+	Transpector XPR 3+ Low Pressure EM
20-30 V (dc), 24 V (dc) Typical, Latching, 4-pin Din connector, internally isolated from system ground	

### 12.13 Ethernet Communication Interface

Transpector XPR 3+	Transpector XPR 3+ Low Pressure EM
Standard: Cat5e Ethernet Cable Connection	

### 12.14 Relay Outputs

Transpector XPR 3+	Transpector XPR 3+ Low Pressure EM
1 relay, 24 V at 0.5 amps	

### 12.15 Inputs

Transpector XPR 3+	Transpector XPR 3+ Low Pressure EM
1 Analog Input, 2 Digital Inputs	

### 12.16 Indicators (Green)

Transpector XPR 3+	Transpector XPR 3+ Low Pressure EM
1 for power status, 1 for emission status	

# Chapter 13

## Supplied Items

### 13.1 Introduction

You will receive the following:

- ◆ A Ship Kit, see [section 13.1.1 on page 13-1](#).
- ◆ An Electronics Module, see [section 13.1.2 on page 13-2](#).
- ◆ An Electronics Module Power Supply
- ◆ A Sensor, see [section 13.1.4 on page 13-3](#).
- ◆ Software (Optional), see [section 13.1.5 on page 13-3](#).
- ◆ Heating Jacket System (Optional)
- ◆ Interlock Kit (Optional)
- ◆ Angle Valve (Optional)

#### 13.1.1 Ship Kit

Table 13-1 Ship kit

Part Number	Description
961-020-G1	Ship Kit
includes:	
600-1198-P8	7 m Ethernet Cable
961-702-G1	Mounting Hardware
961-022-G1	O-ring and Mounting Nut
961-370-P1	O-ring Removal Tool
051-032	D Connector
051-1082	Cable Clamp for D connector
074-5007-G1	Gas Analysis Manuals CD

### 13.1.2 Electronics Module

Table 13-2 Electronics module

<b>(one of the following)</b>	
<b>Part Number</b>	<b>Description</b>
MP-X10P	Transpector XPR 3+ 100 AMU Electronics Box Standard I/O
MP-X13P	Transpector XPR 3+ 100 AMU Electronics Box Extended I/O
MP-X15P	Transpector XPR 3+ 100 AMU Electronics Box Extended I/O with cable break-out box
MP-C10P	Transpector XPR 3+ Advanced 100 AMU Electronics Box Standard I/O
MP-C30P	Transpector XPR 3+ Advanced 100 AMU Electronics Box Extended I/O
MP-C50P	Transpector XPR 3+ Advanced 100 AMU Electronics Box Extended I/O with cable break-out box

### 13.1.3 Power Supply

Table 13-3 Power supply

<b>Part Number</b>	<b>Description</b>
961-021-G1	Power Supply Kit - 85-250 V(ac) 1.2 m (4 ft.) US Plug
961-021-G2	Power Supply Kit - 85-250 V(ac) 1.2 m (4 ft.) US Plug with 4.5 m (15 ft.) Extension
961-021-G3	Power Supply Kit - 85-250 V(ac) 1.2 m (4 ft.) US Plug with 9 m (30 ft.) Extension
961-021-G4	Power Supply Kit - 85-250 V(ac) 1.2 m (4 ft.) DE Plug
961-021-G5	Power Supply Kit - 85-250 V(ac) 1.2 m (4 ft.) DE Plug with 4.5 m (15 ft.) Extension
961-021-G6	Power Supply Kit - 85-250 V(ac) 1.2 m (4 ft.) DE Plug w/ 9 m (30 ft.) Extension
961-021-G7	Power Supply Kit - 85-250 V(ac) 1.2 m (4 ft.) UK Plug
961-021-G8	Power Supply Kit - 85-250 V(ac) 1.2 m (4 ft.) UK Plug with 4.5 m (15 ft.) Extension
961-021-G9	Power Supply Kit - 85-250 V(ac) 1.2 m (4 ft.) UK Plug w/ 9 m (30 ft.) Extension
961-021-G10	Power Supply Kit - 85-250 V(ac) 1.2 m (4 ft.) IL Plug
961-021-G11	Power Supply Kit - 85-250 V(ac) 1.2 m (4 ft.) IL Plug with 4.5 m (15 ft.) Extension
961-021-G12	Power Supply Kit - 85-250 V(ac) 1.2 m (4 ft.) IL Plug w/ 9 m (30 ft.) Extension

### 13.1.4 Sensor

Table 13-4 Sensor

<b>(one of the following):</b>	
<b>Part Number</b>	<b>Description</b>
961-X1HAP	Transpector XPR 3+ HPEM Y <sub>2</sub> O <sub>3</sub> /Ir Filaments
961-X1LAP	Transpector XPR 3+ LPEM Y <sub>2</sub> O <sub>3</sub> /Ir Filaments

### 13.1.5 Software

Software packages are optional and available for Windows only.

Table 13-5 Software

<b>(optional)</b>	
<b>Part Number</b>	<b>Description</b>
921-039-G1	FabGuard Explorer Single Sensor Version - CD
921-039-G2	FabGuard Explorer Multi Sensor Version - CD

### 13.1.6 Heating Jacket System (Optional)

Table 13-6 Heating jacket system (optional)

<b>(one of the following) (optional)</b>	
<b>Part Number</b>	<b>Description</b>
914-415-P1	Interlock Weldment Heating Jacket
600-1487-PX	Heater Power Cable
068-XXXX	Country Specific Power Cord

### 13.1.7 Interlock Kit (Optional)

Table 13-7 Interlock Kit (Optional)

<b>(optional)</b>	
<b>Part Number</b>	<b>Description</b>
914-416-G1	Interlock Weldment
918-401-P1	Pirani Gauge
600-1449-P1	Pirani Interlock Cable

### 13.1.8 Angle Valve (Optional)

Table 13-8 Angle valve (optional)

<b>(optional)</b>	
<b>Part Number</b>	<b>Description</b>
914-024-G1	Angle Valve Kit, Manual (includes Heater, Y-Cable)
961-0250-G1	Angle Valve Kit, Air Operated, 24 V(dc)(includes Heater, Y-Cable)

---

# Index

---

## A

altitude range 1-8  
analyzer factor 4-9, 4-12  
anode 9-1  
    error 7-2  
    voltage 3-7  
anti-seize compound 1-11  
appearance potential 9-1  
atomic mass unit 9-1

## B

background 9-1  
bakeout 9-1, 11-3  
    temperature 6-3

## C

calibrated 4-16  
capacitance manometer 4-11  
center voltage 9-1  
closed ion source 4-15, 9-1  
communication  
    none to host 7-1  
    problems 7-6  
computer  
    cables 12-4  
conductance 9-1  
ConFlat flange  
    assembly 1-10  
constant peak width 4-15  
contamination  
    prevention 3-13  
continuous dynode element 3-12  
control voltages 4-15  
CPU LED 7-1  
cracking pattern 4-3, 9-1  
current rating 1-7  
Customer Support  
    Return Material Authorization 1-3

## D

Dalton's Law 4-8  
DC  
    component 3-7  
    potential 3-7  
DC-to-RF ratio 3-7  
Declaration Of Contamination 1-3  
detection factor 4-12, 4-13, 9-2  
detector 3-1, 9-2  
detector type 11-1

doubly charged ion 9-2

## E

electron energy 3-4, 9-2  
electron multiplier 9-2  
electron stimulated desorption 4-15  
electronics enclosure 11-4  
electronics module 1-5, 12-2  
    physical dimensions 1-6  
EM gain 3-11  
emission current 3-4, 9-2  
emission error 7-2  
emult error 7-2  
energy of the bombarding electrons 4-5  
exit aperture 9-2  
extension kit 12-3  
extractor 3-4, 9-2

## F

faraday  
    cup 3-10, 9-2  
filament 4-14, 9-2  
    kit 10-2  
    replacement 6-6  
focus lens 9-3  
fragment ion 9-3  
fragmentation factor 4-9, 4-13, 4-16, 9-3  
fragmentation pattern 4-3, 4-5, 4-6, 4-15, 9-3

## G

gain of the electron multiplier 4-12, 9-3  
gas consumption 4-15  
gas phase patterns 4-15

## H

heating jacket 6-3  
high-vacuum environment 3-1  
humidity 1-8  
hydrogen fluoride 3-13

## I

I/O 1-23  
    analog inputs 1-24  
    AUX I/O connector 1-23  
    setpoint relays 1-23  
in situ preamplifier 3-11  
inputs 11-4  
integer values 4-3  
ion 9-3



- beam focus 3-4
- cage 3-4
- current 3-10, 9-3
- detector 3-10
- doubly charged 4-3
- energy 3-7, 9-3
- intensity 4-1
- low mass 3-7
- mass-to-charge ratio 4-1
- multiply charged 4-6
- parent 4-3, 9-5
- remove high mass 3-7
- source 1-5, 3-1, 3-2, 4-14, 9-3
- source assembly kit 10-2
- source removal 6-9, 6-11
- total yield 4-15
- ion detector 1-5
- ionization probability 4-9, 4-11, 4-13, 9-4
- ionizer 4-14
- isotope 9-4
- isotope ratios 4-4, 4-6

## **L**

- LED indicators 11-4
- lighter elements 4-4
- linearity 9-4

## **M**

- mass discrimination 4-15
- mass filter 3-1, 3-6, 9-4
- mass range 11-1
- mass spectrometer 9-4
- mass spectrum 3-8, 4-1, 9-4
- mass to charge ratio 9-4
- material factor 4-9, 9-5
- mean-free-path 9-5
- molecular flow 9-5
- mounting requirements 1-7
- multiple peaks 4-3

## **N**

- natural abundance 9-5
- nitrogen trifluoride 3-13
- noise level 7-6

## **O**

- open ion source 9-5
- outgassing 4-14, 9-5
- overvoltage category 1-8

## **P**

- parent ion 9-5
- partial pressure 4-13, 4-16, 9-6

- analyzer 4-8
- pass band width 3-8
- peak height 4-8
- peak shape, poor 7-5
- perimeter for maintenance access 1-7
- pole zero 3-7, 9-6
- pollution degree 1-8
- power
  - input 11-3
  - supply 1-15, 12-2
- pressure maximum 11-2
- pumping 4-14

## **Q**

- quadrupole 9-6
  - exit aperture 3-10
  - exit lens 3-10
  - mass filter 1-5
  - partial pressure analyzer 1-4
  - radius 3-6, 3-7

## **R**

- reactive fluorides 3-13
- relay outputs 11-4
- repeller (electron) 9-6
- required vacuum 1-8
- residual gas analyzer 9-6
- resolution 3-8, 9-6, 11-2
- RF
  - amplitude 3-7
  - error 7-2
  - frequency 3-7
  - potential 3-7

## **RS232**

- setting up 1-15
- specifications 11-4

## **RS485**

- specifications 11-4

## **S**

- secondary electron 9-6
- sensitivity 4-12, 4-15, 9-6, 11-2
  - poor 7-5
- sensor 1-5, 12-2
  - bakeout temperature 1-13
  - cleaning 1-9
  - contaminated 6-1
  - length 11-1
  - max operating temp 11-3
  - mounting near magnetic fields 1-11
- ship kit 12-1
- software 12-4
- spectra 4-1

none 7-4  
spinning rotor gauge 4-11  
supply voltage 1-7  
surface film 3-13

**T**

temperature  
    bakeout 11-3  
    coefficient 11-2  
    error 7-3  
    max operating 11-3  
    operating 11-3  
    operating range 1-8  
total pressure 9-6  
total pressure plate 9-7  
transition flow 9-7  
transmission factor 4-12, 4-13, 9-7  
tuned 4-16  
tungsten hexafluoride 3-13

**U**

ultrahigh vacuum 4-14  
user configured switches 11-4

**V**

vacuum region 4-14  
vacuum system 4-14  
ventilation requirements 1-7  
viscous flow 9-7

**W**

weight 1-6

**Z**

zero blast 9-7