

Measuring viscosity inline and controlling processes

Brabender: Convimeter II





Convimeter II

Measuring viscosity inline and controlling processes – accuracy and method diversity and laboratory level

The Convimeter II enables viscosity measurement and process control in the production and development of liquids and pastes. The innovative measurement concept also opens the way for many measurement methods previously reserved for offline rheology to be used in production environments. This supports the development of manufacturing processes and enables large-volume testing on a production scale.

The Convimeter II can be used both within a control station system and in stand-alone operation. Operation is effortless browser-based via the network or the integrated touch screen.

Brabender has incorporated the experience gained from the Convimeter, which has proven itself for almost 60 years, into the development. Thus, the latest evaluation technology meets solid material and manufacturing quality.

Why Convimeter II as inline- and process viscometer?

- Process viscometers – thanks to adjustable shear rates and large measuring range
- Innovation – functional scope supports the development of new products and processes
- Wide measuring range – 30 - 2,000,000 mPas Newtonian and non-Newtonian liquids
- Hygiene – No bearings or dynamic seals in contact with product
- Mature measurement technology – Recognized in the industry for almost 60 years, tried and tested a thousand times



Control unit with integrated touch screen





Advantages

- Wide range of applications – thanks to adjustable shear rates and large measuring range
- Automation – measurement and control in the ongoing production process
- Rapid substance exchange – through pump effect
- Low shear rates – macroscopic shear at small shear gradients
- Measurement of the overall structure – behavior is not only recorded at an interface, but determined over a macroscopic range
- Precise measurements – viscosity is measured at real prevailing conditions
- CIP – „Clean In Place“

What's new?

- Create viscosity profiles – characterization function
- Shear rate matching – correlation to other viscometers
- Clarity – temporal display of the viscosity curve
- Easy operation – through browser-based operating concept and via the control unit with integrated touch screen
- Easy installation – simple integration via milk pipe fitting or flange and electrical installation via push-pull cable plug
- Platform independent

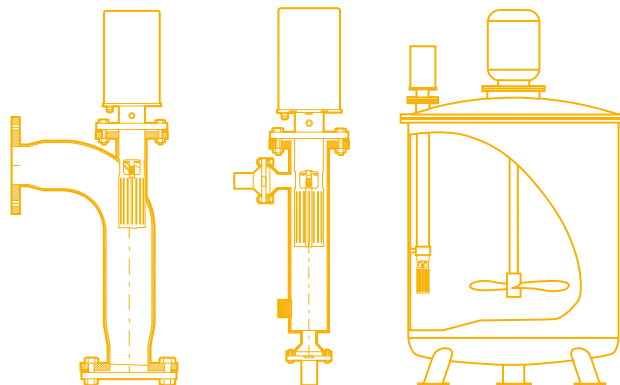

Mounting position examples



Technical Data

- Measurable viscosities: For purely viscous Newtonian and non-Newtonian substances
- Measuring range: 30 to 2,000,000 mPas
- Accuracy: $\pm 0,5\%$ of measured value
- Display: Viscosity in mPas, Pas and cP, viscosity curve t - 20 min., torque in %, speed in min^{-1} , optional: temperature in $^{\circ}\text{C}$
- Operation: Browser-based and/or via the control unit-TS (7" / 17.8 cm touch screen)
- Installation position: any
- Installation options: Flange or milk pipe fitting
- Pressure range: Max. 10 bar / 145 psi
- Measuring temperature range: Max. 130 $^{\circ}\text{C}$ / 266 $^{\circ}\text{F}$
- Ambiente temperature: Max. +5 to +50 $^{\circ}\text{C}$ / 41 to 122 $^{\circ}\text{F}$
- Materials: Wetted parts: stainless steel DIN EN 10088 - 1.4307 - AISI/SAE 304L
- Interfaces: 4 - 20mA, TCP
- Power supply: 100V - 240V, -15% / +10%, 50-60Hz, max. 250W
- Protection class: Measuring head: IP67 / Control unit: IP64
- Dimensions (W x D x H):
Measuring head: 185 x 514 x 162 mm / 7.28 x 20.24 x 6.38 in
Control unit: 483 x 178 x 265 mm / 19 x 7 x 10.43 in (19"-4 HE)

Fields of application

The CONVIMETER II is designed for industrial food production. Through decades of experience with the CONVIMETER I, further areas of application are possible within the working range, for example in the bodycare or paper segments.



Measuring method

The measuring method is based on the further development of the rotational viscometer principle. The Convimeter I already worked here with a tumbling motion, which ensures good substance exchange and macroscopic shear at small shear gradients.

With the Convimeter II, the measurement is now fully digitalized, resulting in a reduction of moving parts and thus in particular ease of maintenance and robustness. The fully digital signal processing is the basis for the innovative measurement functions available with the Convimeter II.

For product and process development, the Convimeter II has special measurement programs:

Create viscosity profiles - Characterization
In food production, ingredient blends with non-Newtonian behavior are regularly encountered. With the

„Characterization“ measuring program, the rheological behavior can be analyzed using a precisely definable speed profile. The results support the planning or adaptation of production processes. New or modified formulations can thus be tested on a large scale under real conditions. The measurement results are available directly on the operating unit or on any browser-capable device in the same network.

Shear rate matching - measured value matching
In the case of prescribed quality controls in the laboratory, the conditions in production can only be reproduced to a limited extent. This is due to the fact that shear rate-dependent viscosities from a laboratory environment cannot be easily transferred to a process section. With the help of shear rate matching, the measured values can be matched (within the speed range).es) angleichen.

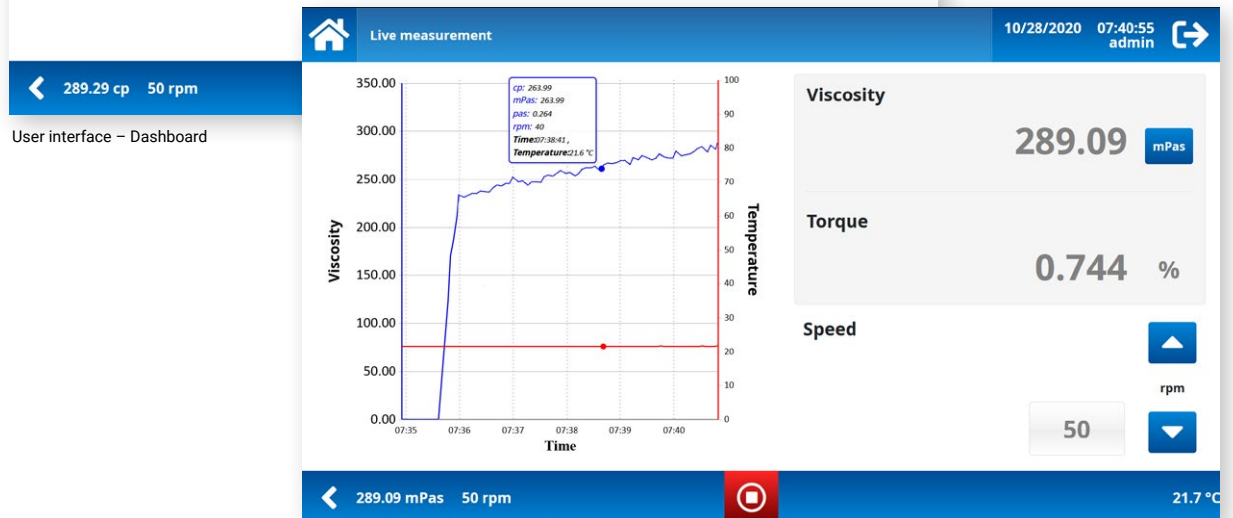
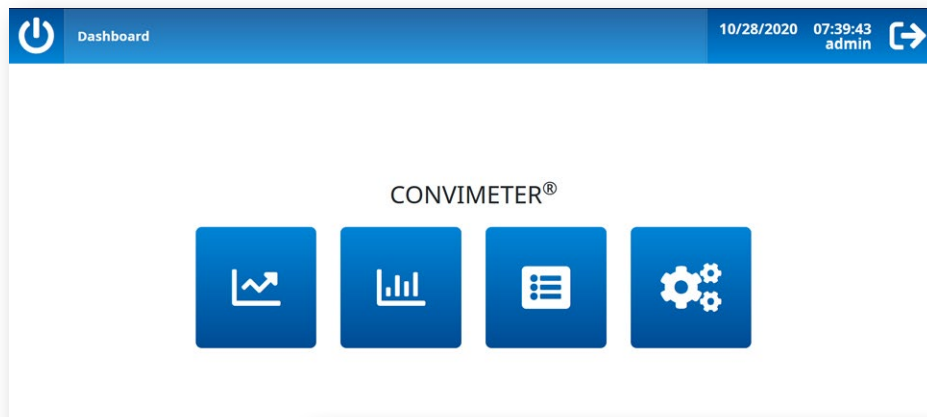

User interface – Dashboard

User interface – Live measurement

