

Features

Frequency range of 150 kHz to 30 MHz

100 Amp_(AC) (forced air cooling)

Fully compliant with CISPR 16-1-2 / ANSI C63.4

“Air-core” inductors to prevent saturation

Individual Calibration Included

Three-Year Warranty

Description

The LI-1100C Line Impedance Stabilization Network (LISN) provides the necessary measurement platform for performing power line conducted emissions compliance testing as required by most worldwide standards for commercial products. The LI-1100C is compliant with both CISPR 16-1-2 and ANSI C63.4.

The LISN provides defined stable impedance and isolates the EUT from power source influences, thereby providing accurate and repeatable results.

The LI-1100C includes one pair of, separately housed, single-conductor networks, to be installed in series with each current-carrying conductor in a single-phase, dual-phase or DC power system. A second LI-1100C pair can be used to accommodate 3-phase power systems (Wye or Delta configurations).

The LI-1100C is equipped with Superior Electric SUPERCON® shrouded sockets at the mains (power input) and EUT (power output) ports. The matching color-coded plugs for connection to the mains and EUT wiring are included.

This LISN uses air-core inductors to prevent saturation and permeability variation. The mounting plate of the LI-1100C is left unpainted in order to facilitate connection to earth ground in its installation, which is essential due to high leakage current.



Use of a Transient Limiter for impedance matching, reduction of out-of-band emissions and transient protection for your measurement instrument is highly recommended and available from Com-Power.

All Com-Power LISNs are individually calibrated in compliance with the relevant requirements of CISPR 16-1-2 and ANSI C63.4. Impedance, Phase, Isolation, and Insertion Loss data is supplied with each unit, along with the calibration certificate.

Typical Connection Diagrams

Single Phase connection with one set of LISN

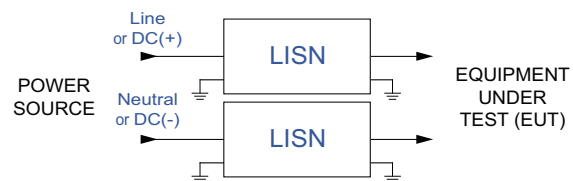

Three Phase connection with two sets of LISNs

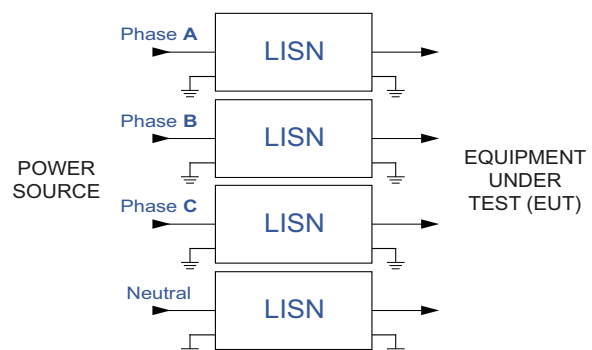

Application

Product Name	Line Impedance Stabilization Network (LISN)
Specification	CISPR 16-1-2 / ANSI C63.4
Application	Power line conducted emissions tests
Frequency Range	150 kHz to 30 MHz
RF Connector	50Ω N-type (female)
Current Rating	100 Amperes _(AC) , 70 Amperes _(DC)
Voltage Rating	440 VAC (Line to Ground), 620 VDC
Inductors	50 μH (air-core)
Mains & EUT Connections	Superior Electric SUPERCON ® shrouded sockets
Dimensions (each network)	10 x 10 x 21 inches / 25.4 x 25.4 x 53.3 cm
Weight (each network)	17 lbs. / 7.7 kg
Insertion Loss	< 0.5 dB (150 kHz to 30 MHz)
Isolation	> 40 dB (150 kHz to 30 MHz)
Fan Power Adapter	Input: 120/230 VAC 60/50Hz, Output: 6 VDC 0.5 Amperes

All specifications are subject to change without notice.
All values are typical, unless specified.

