

LDS® Vibration Test Solutions

LDS V8800 Shaker

The LDS® V8800 shaker system takes the long-standing reliability of the LDS V8 and enhances its capability, with outstanding shock performance, energy consumption savings (COOL mode), intuitive user interface, preventative maintenance system diagnostics and increased reliability with the inductive centring system (ICS). The V8800 shaker is available in various configurations: base mount, lin-e-air trunnion-mounted and combo slip table. Additional options include air glides, thermal management systems and head expanders.

V8800 Base Mount Shaker

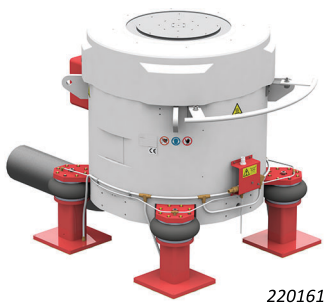

220161

Lin-E-Air Trunnion-Mounted V8800 Shaker

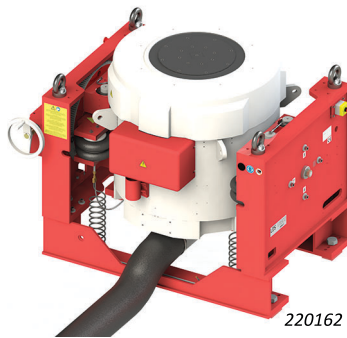

220162

V8800 Combo-Mounted Shaker
with HBT Slip Table

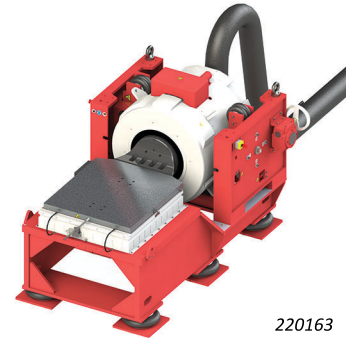

220163

Key Performance Parameters

Armature Diameter	440 mm (17.3 in)	
Sine Force (peak)	59.0 kN (13,250 lbf)	
Random Force (rms)*	66.0 kN (14,837 lbf)	
Max. ½-Sine Shock Force (peak)*	with XPA64K Amplifier	130.0 kN (29,225 lbf)
	with XPA88K Amplifier	175.0 kN (39,340 lbf)
Sine Acceleration (peak)	1,370 m/s ² (140.0 g _n)	
Random Acceleration (rms)	980 m/s ² (100.0 g _n)	
Sine Velocity – full field (peak)	2.0 m/s (78.7 in/s)	
Sine Velocity – reduced field (peak)	2.5 m/s (98.4 in/s)	
Shock Velocity (peak)	4.2 m/s (165.4 in/s)	
Displacement (peak - peak)†	76.2 mm (3.0 in)	
Required Amplifier	LDS XPA64K, LDS XPA88K	

* Random and shock ratings assume an m40 payload as specified by ISO 5344; shock pulse 2 ms

† Displacement can vary with payload and shaker orientation. Please contact HBK for advice on specific test requirements

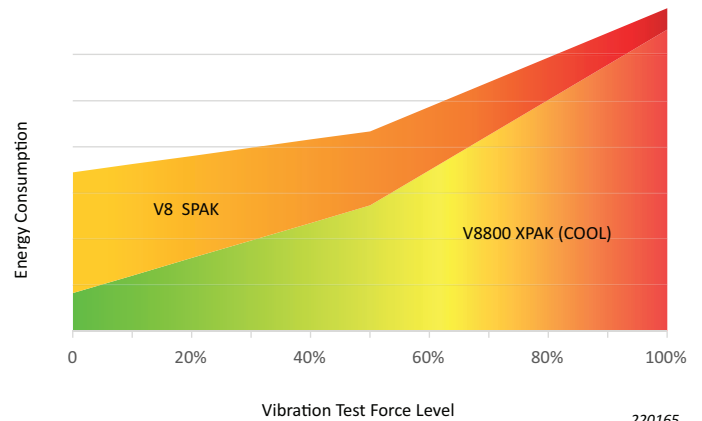

220165

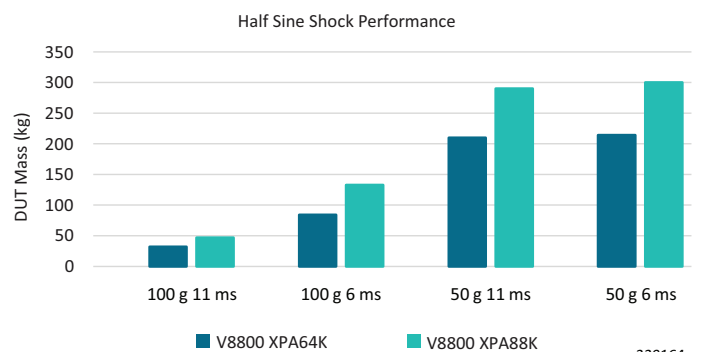

220164

Shaker Specifications

Performance Parameters

Armature Diameter	440 mm (17.3 in)
Usable Frequency Range*	5 Hz to 3,000 Hz
Effective Moving Mass	43.0 kg (94.8 lb)
Armature Resonance (f_n)	1,900 Hz (nominal)
Body Suspension Resonance	Lin-E-Air Suspension: < 5 Hz Air Isolation Mounts: < 10 Hz
Overturning Moment Restraint	1,300 Nm (11,506 lbf in)
Internal Load Support Capacity	700 kg (1,540 lb)
Shaker Body Mass	Base Mount: 3,050 kg (6724 lb) Trunnion Mount: 3,250 kg (7165 lb)
Shaker Total Mass	Base Mount: 3,200 kg (7,055 lb) Trunnion Mount: 4,400 kg (9,700 lb)
Stray Magnetic Field† (Standard)	Base Mount: < 1.6 mT (16 gauss) Trunnion Mount: < 1.5 mT (15 gauss)

* Force will be reduced above 2200 Hz dependant upon payload and payload fixture dynamic response.

† Theoretic maximum, measured 150 mm (6 in) above table, full-field, at normal operating temperature.

V8800 Armature Inserts

Raised insert options available, stainless steel, M8, M10, or 3/8 UNC

- 1 insert at centre of armature
- 8 inserts on 203.2 mm (8 in) PCD
- 8 inserts on 406.4 mm (16 in) PCD

* PCD = pitch circle diameter

Ancillaries

Cooling Fan

The V8800 fan is supplied with an inverter that enables the fan speed to be controlled automatically (COOL mode) or manually, to reduce power consumption and acoustic noise for lower level tests. The acoustic noise level can be further reduced by attaching a silencer to the fan outlet, or by placing the fan in an acoustic enclosure.

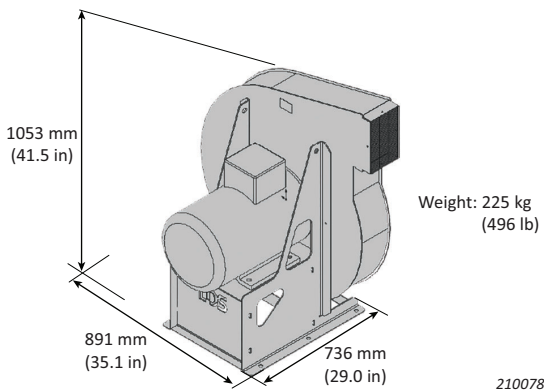

Shaker Physical Characteristics

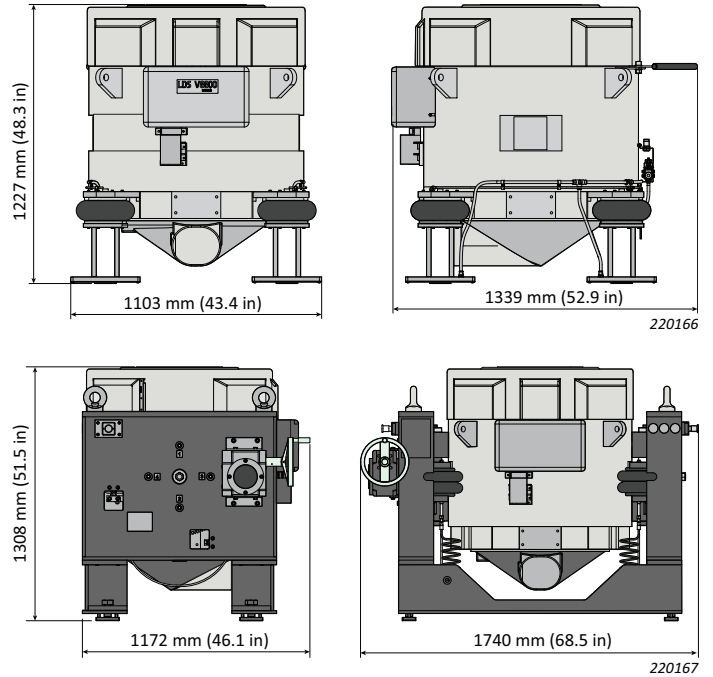

Combo slip tables are available with low-pressure bearings (LPT) for compact test loads, and hydrostatic bearings (HBT) for larger test loads with higher overturning moments. The following slip table sizes are available as standard: LPT600, 750, 900 and 1220; and HBT600, 750, 900 and 1220.

HBT Slip Table Hydraulic Unit

HBT slip tables use a stand-alone hydraulic pump for the bearings. With LPT slip tables, the hydraulic pump supply is installed inside the table.

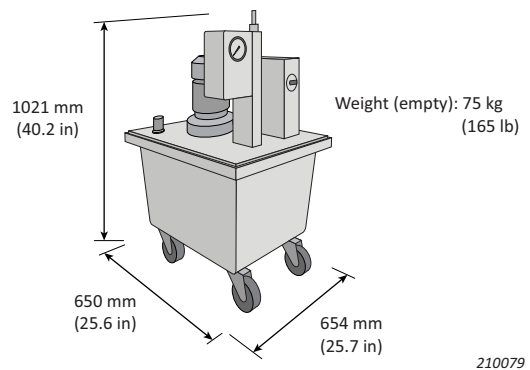

The Amplifier

The LDS XPAK Amplifier is available as 64 kVA for maximum sine and random performance, and as 88 kVA for enhanced shock performance.

It has an intuitive touchscreen user interface displaying system performance characteristics such as interlocks, temperatures, voltage and current readings, power consumption and power savings – depending upon the mode selected either: Standard, Quiet or COOL.

Fig. 1 XPAK Amplifier intuitive touch screen user interface

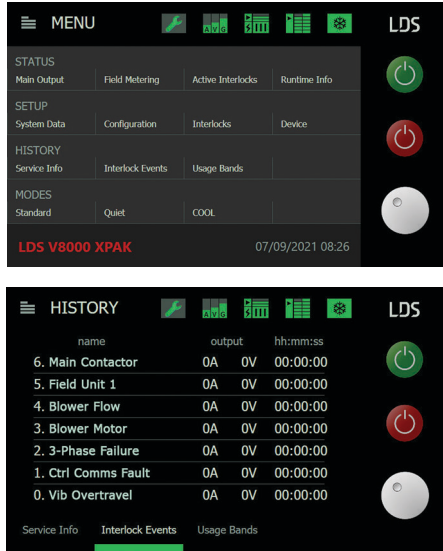

In Quiet mode, the system can be run with the fan switched off for short periods at low force to minimise acoustic noise. This is particularly useful for squeak and rattle test applications.

In COOL mode, the amplifier actively monitors the system parameters to reduce the power consumption required for a particular test. This can significantly reduce running costs.

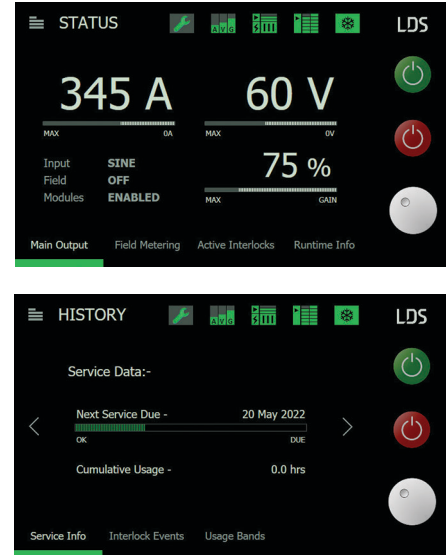

The XPAK amplifier uses CAN bus communications from the shaker via the pneumatics control unit to provide continuous monitoring of the system performance. This data is available to you in real time via the amplifier's touchscreen interface. To support preventive maintenance and fault detection, the data is also stored in the amplifier for subsequent analysis.

Fig. 2 Internal diagnostics within the XPAK Amplifier

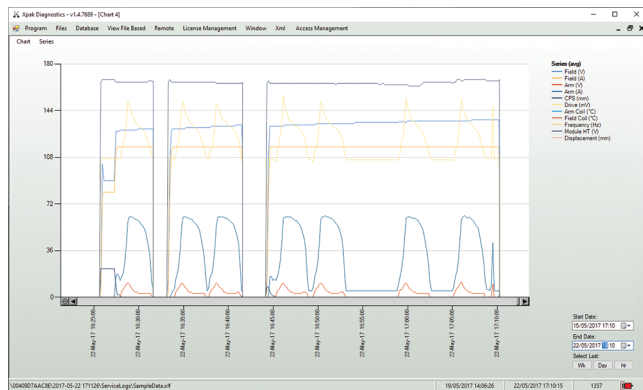
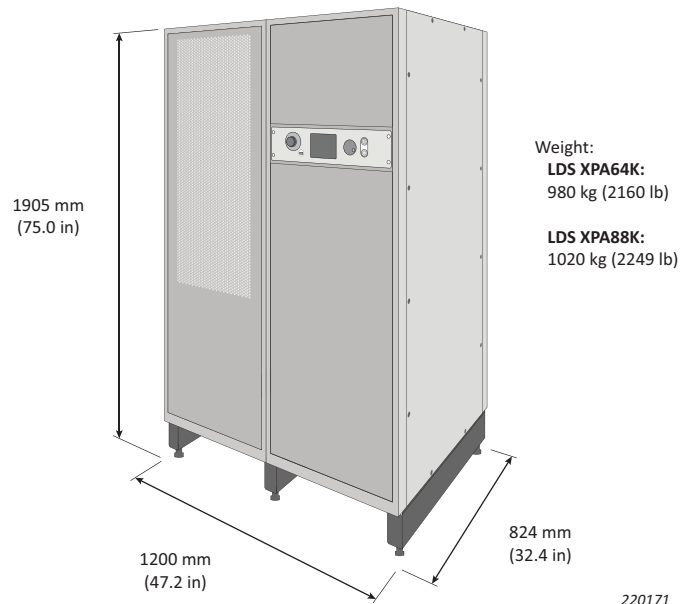

Fig. 3 Physical characteristics of the XPAK Amplifier



Pneumatics Control Unit

The pneumatics control unit also includes an emergency stop, pneumatics controls for lin-e-air and internal load support, and indicators for armature position and internal load support pressure.

Fig. 4 Physical characteristics of the pneumatics control unit

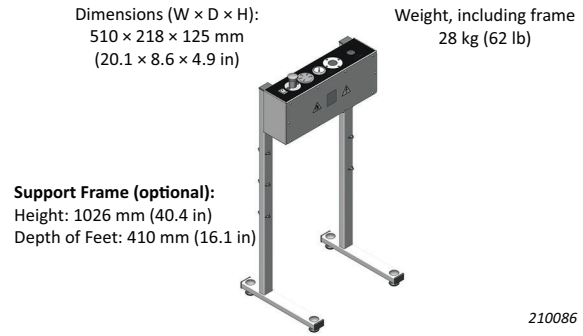

System Specifications

Environmental Data

WORKING AMBIENT TEMPERATURE RANGE	
Shaker	+7 to 30 °C (+45 to 86 °F)
XPAK Amplifier	+5 to 30 °C (+41 to 86 °F)
MAXIMUM ACOUSTIC NOISE AT 1 m (3.3 ft) DISTANCE*	
Shaker	108 dBA
XPAK Amplifier	74 dBA
Cooling Fan	102 dBA
Cooling Fan with Silencer	99 dBA
Cooling Fan in Acoustic Enclosure	<80 dBA
TOTAL HEAT DISSIPATION	
Shaker to Air (from body)	2.4 kW
XPA64K Amplifier	8.7 kW
XPA88K Amplifier	10.5 kW
Cooling Fan	57.0 kW
COOLING AIRFLOW	
Shaker via Cooling Fan	1.1 m ³ /s (2331 ft ³ /min)
XPA64K Amplifier	0.9 m ³ /s (1907 ft ³ /min)
XPA88K Amplifier	1.1 m ³ /s (2331 ft ³ /min)

* Maximum acoustic noise levels do not take into account any noise that may be generated due to payloads attached to the vibration testing system

Electrical and Compressed Air Supply

GENERAL	
Voltage 3-phase (standard)	380 to 480 V, 50/60 Hz
Compressed Air Supply	6.9 bar (100 lbf/in ²)
TOTAL ELECTRICAL REQUIREMENTS AMPLIFIER AND FAN (STEADY STATE)	
XPA64K Amplifier	80 kVA (Type B MCB) 75 kVA (Type C MCB)
XPA88K Amplifier	95 kVA (Type B MCB) 75 kVA (Type C MCB)
TOTAL ELECTRICAL REQUIREMENTS ANCILLARIES (STEADY STATE)	
HBT Hydraulic Unit (3-phase)	1.5 kVA
LPT Hydraulic Unit (single phase)	180 VA
Pneumatics Control Unit (single phase)	32 VA

Safety

Complies with the following EU directives:

- Machinery: 2006/42/EC
- Low Voltage: 2014/35/EU
- EMC: 2014/30/EU
- Designed in accordance with EN 61010-1:2010

Complies with the following UK directives:

- Supply of Machinery (Safety) Regulations 2008
- Electrical Equipment (Safety) Regulations 2016
- Electromagnetic Compatibility Regulations 2016
- Designed in accordance with BS EN 61010-1:2010

Jarman Way · Royston, Hertfordshire · SG8 5BQ United Kingdom
Telephone: +44 1223 389800
www.bksv.com/LDS · info@bksv.com
Local representatives and service organizations worldwide

To learn more about all HBK offerings, please visit hbkworld.com

Although reasonable care has been taken to ensure the information in this document is accurate, nothing herein can be construed to imply representation or warranty as to its accuracy, currency or completeness, nor is it intended to form the basis of any contract. Content is subject to change without notice – contact HBK for the latest version of this document.

LDS and all other trademarks, service marks, trade names, logos and product names are the property of Hottinger Brüel & Kjær or a third-party company.

