

Tap Changer Analyzer & Winding Ohmmeter

RMO-TD Series

- On-load tap changer (OLTC) dynamic resistance measurement DVtest
- Three measurement channels
- One temperature measurement channel
- Tap changer motor current monitoring channel
- Built-in tap changer control unit
- Automatic resistance measurement for the Heat Run test
- Rapid automatic demagnetization
- Automatic discharge circuit



Description

The Winding Resistance Ohmmeter of the RMO-TD series is designed for winding resistance measurement of inductive objects. The RMO-TD instrument is based on the state of the art technology, using the most advanced switch mode technology available today. The RMO-TD instrument is accurate (0,1% rdg + 0,1% F.S.), powerful (up to 60 A). It generates a true DC ripple free current with automatically regulated measurement and discharging circuit.

RMO-TD series can perform simple, quick and reliable transformer on-load tap changer condition assessment. This series enables

measurements of a winding resistance in every tap position, current ripple values and transition times during the tap changes. Problems with the connection, contacts, and selector/diverter switch operation can be detected with these measurements.

RMO-TD instruments are equipped with thermal and overcurrent protection. They have a very high ability to cancel electrostatic and electromagnetic interference that exists in HV electric fields. It is achieved by a proprietary filtration solution applied to both the hardware construction and the application software implementation

Application

The list of the instrument application includes:

- Winding resistance measurement of inductive test objects, such as transformers and rotating machines, resistance measurement for non-inductive test objects (circuit breaker, bus bars, etc.)
- Dynamic resistance measurement (DVtest) of on-load tap changers, performed on a single phase
- A measurement of on-load tap changer motor current by using a dedicated channel
- Heat Run test, which enables obtaining the Hot Spot temperature along with resistance graph during the cooling process
- A single-phase automatic transformer demagnetization

Connecting RMO-TD to Test Object

Three-phase Transformer

RMO-TD is a single-phase device, which means it can be connected to one phase of a transformer at a time. It has 3 resistance measurement

channels, which allows simultaneous testing of up to 3 windings. Those windings need to be externally connected in series.

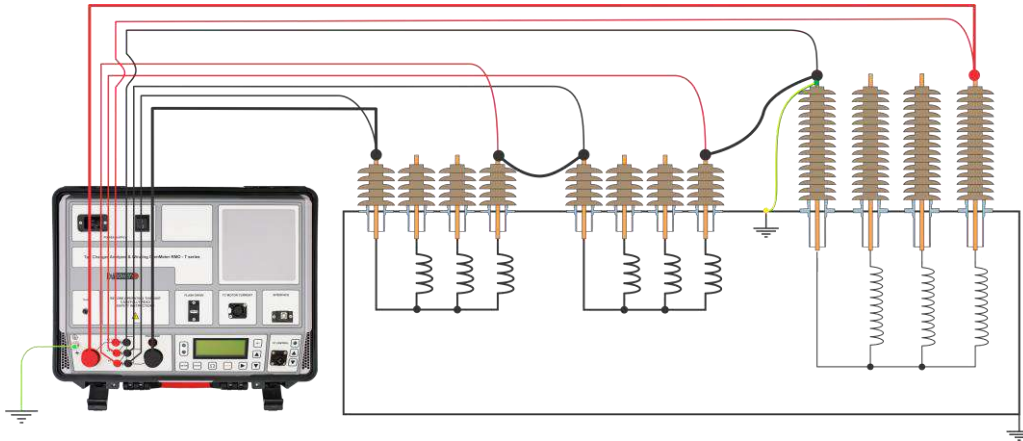

RMO-TD is a single-phase device capable of performing quick and reliable transformer OLTC

condition assessment. It is connected to one phase of a transformer at a time.

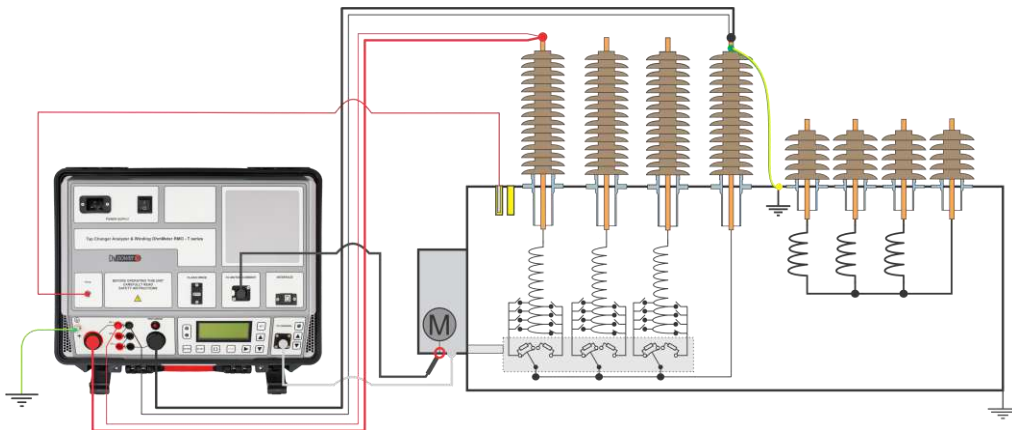

Three-phase Motor/Generator

Using three separate resistance measurement channels available in RMO-TD, it is possible to simultaneously measure all 3 phases of a

motor/generator stator windings. To do this, all 3 phases need to be externally connected in series.

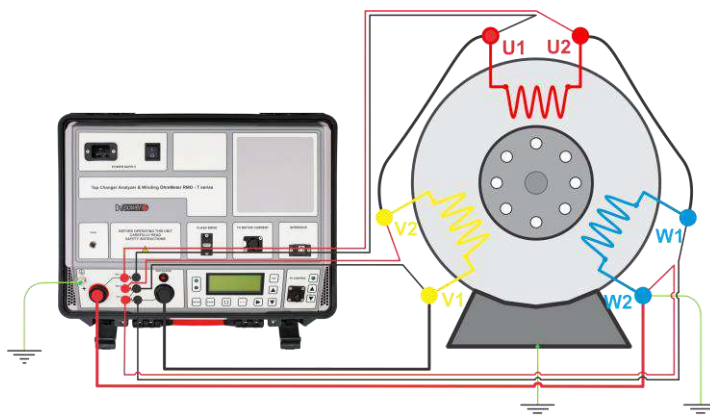

Benefits and Features

Test Voltage up to 55 V DC

RMO-TD injects the current with a voltage value as high as 55 V. This ensures that the magnetic core is saturated quickly, and duration of the test is as short as possible.

Simultaneous Three-Channel Winding Resistance Measurement

Three independent resistance measurement channels enable simultaneous testing of up to 3 windings connected in series – a primary, a secondary, and a tertiary transformer winding. This significantly speeds up the measurement and reduces the total transformer testing time. At the same time, by saturating the magnetic core through the primary winding, which has the higher number of turns, the stabilization time and subsequently the total testing time is further reduced.

DVtest On Load Tap Changer Dynamic Resistance Measurement (DRM)

RMO-TD can be used for measuring winding resistance of individual taps of a power transformer with OLTC without test current interruption between the tests. If interruption is detected (test current drops to zero) during tap change, the instrument produces a warning message to the operator. The unit also checks whether OLTC switches without an interruption. The moment a tap position is changed from one tap to another, the device detects a sudden, very short drop of the test current. These drops called "Ripple". Tap changer malfunctions can be detected by analyzing the measurements of transition ripple, transition time, and visualizing DRM graphs. In addition, the tap changer motor current is recorded, and displayed on the same graph.

Transformer Demagnetization

After a DC current test, such as a winding resistance measurement, the magnetic core of

a power or a measurement transformer may be magnetized. Also, when disconnecting a transformer from a service, some amount of magnetic flux trapped in the core could be present. Demagnetizing the magnetic core of a transformer requires alternating current applied with decreasing magnitude down to zero. RMO-TD instruments provide this alternating current by internally changing the polarity of a controlled DC current. During the demagnetization process the test current is supplied with decreasing magnitude for each step, following the proprietary developed program.

DV-TR Software

The DV-TR application software enables control and observation of the test process, as well as saving and analyzing the results on a PC. It provides a test report, arranged in a selectable form as an Excel spreadsheet, PDF, or Word. The software provides additional OLTC verification option by recording the test current during the transition. The standard interface is USB. RS232 is optional.

Heat Run Test Application

The DV-TR application software has an additional Heat Run temperature/resistance extrapolation feature. After the transformer heating is switched off, the RMO-TD is immediately connected to up to three transformer windings and the timer is started. The winding resistance is measured at regular time intervals. This information is used to automatically extrapolate the values of temperature and resistance at the moment when the transformer was switched off.

Built-in Printer

Built-in thermal printer, 58 mm (2.3 in) wide, is an optional accessory. All numerical results can be printed either right after the test or later from any previously saved result.

Technical Data

Mains Power Supply

- Connection according to IEC/EN60320-1; UL498, CSA 22.2
- Mains supply: 90 – 264 V AC, 50/60 Hz
- Input power:
 - 1 800 VA (RMO25TD)
 - 2 250 VA (RMO25TD and RMO60TD)

Winding Resistance Measurement

- Test currents:
 - RMO25TD: 5 mA – 25 A DC
 - RMO40TD: 5 mA – 40 A DC
 - RMO60TD: 5 mA – 60 A DC
- Output voltage: up to 55 V DC
- Measurement range: 0,1 $\mu\Omega$ - 100 k Ω
- Measurement range / Typical accuracy:
 - 0.1 $\mu\Omega$ – 1.999 k Ω : \pm (0.1% rdg + 0.1% F.S.)
 - 2 k Ω – 9.999 k Ω : \pm (0.2% rdg + 0.1% F.S.)
 - 10 k Ω – 100 k Ω : \pm (1.0% rdg + 1.0% F.S.)
- Measurement range / Resolution:

0.1 $\mu\Omega$ – 999.9 $\mu\Omega$:	0.1 $\mu\Omega$
1.000 m Ω – 9.999 m Ω :	1 $\mu\Omega$
10.00 m Ω – 99.99 m Ω :	10 $\mu\Omega$
100.0 m Ω – 999.9 m Ω :	0.1 m Ω
1.000 Ω – 9.999 Ω :	1 m Ω
10.00 Ω – 99.99 Ω :	10 m Ω
100.0 Ω – 999.9 Ω :	0.1 Ω
1.000 k Ω – 9.999 k Ω :	1 Ω
10.00 k Ω – 99.99 k Ω :	10 Ω

OLTC DVtest (DRM)

- Sampling rate: 0,1 ms

Temperature Measurement

- Measurement range
 - 50 °C – +180 °C / -58 °F – +356 °F
- Thermometer Pt100 class B
- Resolution 0,1 °C

Data Storage

- 1000 memory positions (standard)
- 5000 memory positions (optional)

Display

- LCD screen 20 characters by 4 lines, with backlight, visible in bright sunlight

Computer Interface

- USB (standard)
- RS232 (optional)
- Bluetooth (optional)

Printer (optional)

- Built-in thermal printer
- Paper width 58 mm / 2.3 in
- Printer operating temperature:
 - 20 °C – +70 °C / -4 °F – +158 °F

Environmental Protection

- Ingress protection rating: IP67 (with closed lid)

Environmental Conditions

- Operating temperature:
 - 20 °C – +60 °C / -4 °F – +140 °F
- Storage & transportation temperature:
 - 40 °C – +70 °C / -40 °F – +158 °F
- Humidity: 0 – 95% relative humidity, non-condensing

Dimensions and Weight

Device	Weight	Dimensions (WxHxD)
RMO25TD	13 kg / 28.6 lbs	478 x 194 x 389 mm 18.82 x 7.64 x 15.33 in
RMO40TD	13 kg / 28.6 lbs	478 x 194 x 389 mm 18.82 x 7.64 x 15.33 in
RMO60TD	13.2 kg / 29.1 lbs	478 x 194 x 389 mm 18.82 x 7.64 x 15.33 in

Warranty

- 3 years + 1 additional year upon registration on [DV Power official website](#)

Applicable Standards

- Installation/Overvoltage category: II
- Pollution degree: 2
- Safety: LVD 2014/35/EU (CE Conform)
 - Standard EN 61010-1:2010
 - CAN/CSA-C22.2 No. 61010-1, 2nd edition, including Amendment 1
- EMC: Directive 2014/30/EU (CE Conform)
 - Standard EN 61326-1:2010

All specifications herein are valid at ambient temperature of +25 °C / +77 °F and standard accessories.
 Specifications are subject to change without notice.
 Specifications are valid if the instrument is used with the standard set of accessories.

Current and sense cables with TTA clamps	Voltage sense cables with TTA clamps	Current connection cable with TTA clamps	Mains power cable
Plastic transport case	Cable plastic case – large size	Cable plastic case – medium size	Cable bag
Bluetooth communication module	Test shunt	Temperature sensor with cable	Tap changer control cable

RMO-TD Series – Models

RMO60TD

	<p>Test current: 5 mA – 60 A</p> <p>Open voltage: Up to 55 V</p> <p>OLCT DVtest (DRM): 0,1 ms</p> <p>Output power: 1000 W</p>	<p>Dimensions (W x H x D): 478 x 194 x 389 mm 18.82 x 7.64 x 15.33 in</p> <p>Weight: 13,2 kg 29.1 lbs</p>
---	---	---

RMO40TD

	<p>Test current: 5 mA – 40 A</p> <p>Open voltage: Up to 55 V</p> <p>OLCT DVtest (DRM): 0,1 ms</p> <p>Output power: 900 W</p>	<p>Dimensions (W x H x D): 478 x 194 x 389 mm 18.82 x 7.64 x 15.33 in</p> <p>Weight: 13,0 kg 28.6 lbs</p>
--	--	---

RMO25TD

	<p>Test current: 5 mA – 25 A</p> <p>Open voltage: Up to 55 V</p> <p>OLCT DVtest (DRM): 0,1 ms</p> <p>Output power: 700 W</p>	<p>Dimensions (W x H x D): 478 x 194 x 389 mm 18.82 x 7.64 x 15.33 in</p> <p>Weight: 13,0 kg 28.6 lbs</p>
---	--	---

Order Info

Instrument with included accessories	Article No
Tap Changer Analyzers & Winding Ohmmeters RMO-TD	RMO25TD-L-03 RMO40TD-L-03 RMO60TD-N-03
DV-TR PC software including USB cable	
Built-in Tap Changer Control Unit	
Tap Changer Control cable 5 m (16.4 ft)	
Mains Power cable	
Ground (PE) cable	
Plastic transport case	

Standard accessories	Article No
Current cables 2 x 10 m 10 mm ² (32.8 ft, 7 AWG) and Sense cables 2 x 10 m (32.8 ft) with TTA clamps	CS-10-10LMWC
Sense cables 2 x 10 m (32.8 ft) with TTA clamps	S2-10-02BPWC
Current connection cable 1 x 5 m 10 mm ² (16.4 ft, 7 AWG) with TTA clamps	CX-05-102XWC
Current clamp 30/300 A supply from the instrument with extension 5 m (16.4 ft)	CACL-0300-06
Cable bag	CABLE-BAG-00

Optional accessories	Article No
Current cables 2 x 5 m 10 mm ² (16.4 ft, 7 AWG) with TTA clamps	C2-05-10LMWC
Current cables 2 x 10 m 10 mm ² (32.8 ft, 7 AWG) with TTA clamps	C2-10-10LMWC
Current cables 2 x 10 m 16 mm ² (32.8 ft, 5 AWG) with TTA clamps	C2-10-16LMWC
Current cables 2 x 15 m 10 mm ² (49.2 ft, 7 AWG) with TTA clamps	C2-15-10LMWC
Current cables 2 x 15 m 16 mm ² (49.2 ft, 5 AWG) with TTA clamps	C2-15-16LMWC
Current cables 2 x 20 m 10 mm ² (65.6 ft, 7 AWG) with TTA clamps	C2-20-10LMWC
Current cables 2 x 20 m 16 mm ² (65.6 ft, 7 AWG) with TTA clamps	C2-20-16LMWC
Current cables 2 x 10 m 10 mm ² (32.8 ft, 7 AWG) and Sense cables 2 x 10 m (32.8 ft) with TTA clamps	CS-10-10LMWC
Current cables 2 x 10 m 16 mm ² (32.8 ft, 5 AWG) and Sense cables 2 x 10 m (32.8 ft) with TTA clamps	CS-10-16LMWC
Current cables 2 x 15 m 10 mm ² (49.2 ft, 7 AWG) and Sense cables 2 x 15 m (49.2 ft) with TTA clamps	CS-15-10LMWC
Current cables 2 x 15 m 16 mm ² (49.2 ft, 5 AWG) and Sense cables 2 x 15 m (49.2 ft) with TTA clamps	CS-15-16LMWC
Current cables 2 x 15 m 25 mm ² (49.2 ft, 3 AWG) and Sense cables 2 x 15 m (49.2 ft) with TTA clamps	CS-15-25LMWC
Current cables 2 x 20 m 10 mm ² (65.6 ft, 7 AWG) and Sense cables 2 x 20 m (65.6 ft) with TTA clamps	CS-20-10LMWC
Current cables 2 x 20 m 16 mm ² (65.6 ft, 5 AWG) and Sense cables 2 x 20 m (65.6 ft) with TTA clamps	CS-20-16LMWC
Current cables 2 x 20 m 35 mm ² (65.6 ft, 2 AWG) and Sense cables 2 x 20 m (65.6 ft) with TTA clamps	CS-20-35LMWC

Sense cables 2 x 5 m (16.4 ft) with TTA clamps	S2-05-02BPWC
Sense cables 2 x 10 m (32.8 ft) with TTA clamps	S2-10-02BPWC
Sense cables 2 x 15 m (49.2 ft) with TTA clamps	S2-15-02BPWC
Sense cables 2 x 20 m (65.6 ft) with TTA clamps	S2-20-02BPWC
Current connection cable 1 x 5 m 10 mm ² (16.4 ft, 7 AWG) with TTA clamps	CX-05-102XWC
Current connection cable 1 x 5 m 16 mm ² (16.4 ft, 5 AWG) with TTA clamps	CX-05-162XWC
Current connection cable 1 x 12 m 10 mm ² (39.4 ft, 7 AWG) with TTA clamps	CX-12-102XWC
Current connection cable 1 x 12 m 16 mm ² (39.4 ft, 5 AWG) with TTA clamps	CX-12-162XWC
Current clamp 30/300 A supplied from the instrument with extension 5 m (16,4 ft)	CACL-0300-06
Temperature sensor 1 x 50 mm (1,97 in) + 5 m (16,4 ft) cable	TEMP1-050-05
Temperature sensor 1 x 50 mm (1,97 in) + 10 m (32,8 ft) cable	TEMP1-050-10
Temperature sensor 1 x 50 mm (1,97 in) + 15 m (49,2 ft) cable	TEMP1-050-15
Temperature sensor 1 x 50 mm (1,97 in) + 20 m (65,6 ft) cable	TEMP1-050-20
Test Shunt 150 A / 150 mV	SHUNT-150-MK
Plastic transport case – medium size	PLCAS-P00-02
Plastic transport case with wheels– medium size	PLCAS-P00-W2
Cable bag	CABLE-BAG-00
Cable plastic case - small size	CABLE-CAS-01
Cable plastic case - medium size	CABLE-CAS-02
Cable plastic case with wheels - medium size	CABLE-CAS-W2
Cable plastic case - large size	CABLE-CAS-03
Cable plastic case with wheels - large size	CABLE-CAS-W3
Built in thermal printer 58 mm (2.28 in)	PRINT-058-01
Thermal paper roll 58 mm (2.28 in)	PRINT-058-RO
Bluetooth communication module	BLUET-MOD-01
Tap Changer Simulator with cable set	TAPC-SIM-000