

Operating Instructions
BB 200 Jaw Crusher

Retsch[®]

Information on these operating instructions

The present operating instructions for the Model BB 200 jaw crusher provides all the required information on the topics mentioned in the table of contents.

These guidelines are provided for the use of the groups specified in each chapter and will ensure safe operation of the BB 200, for the purpose for which it was intended. Familiarity with the pertinent chapters is a prerequisite for confident, proper utilization by the various persons who deal with the machine.

The present technical manual is designed for use both as a reference work and as a learning guide. Each of the individual chapters is a self-contained unit.

These operating instructions do not contain any information on repairs. If repairs should ever become necessary, kindly get in touch with your supplier or contact directly the Retsch GmbH.

Information on these operating instructions	2
Safety	4
Safety note	4
Warnings	5
Repairs	5
Confirmation.....	5
Technical specifications	6
Utilization in accordance with the intended purpose.....	6
Gap width adjustment range	6
Throughput rate and ultimate fineness	6
Receiver drawer volume	6
Electrical protection class	6
Mains connection.....	6
Rated power.....	6
Pre-fuse	6
Electromagnetic Compatibility (EMC)	6
Noise emissions.....	7
Equipment dimensions (approximate).....	7
Footprint.....	7
Shipping and installation.....	8
Packing	8
Shipping	8
Intermediate storage.....	8
Intermediate storage.....	8
Requirements for the installation site	8
Installation.....	9
Electrical connection	9
Operation.....	10
Control elements and their use	10
Schematic view of the operating controls , part 1:	10
Control elements and their use	11
Schematic view of the operating controls, part 2:	11
The operating controls and their functions.....	12
Summary table	12
Starting the BB 200	13
Stopping the BB 200	13
Emptying the receiver drawer	13
Dust extraction.....	14
Adjust the gap width	14
Adjusting the zero setting for the gap width	14
Fill product to be ground	14
Working instructions.....	15
General	15
Grain size of feedstock product	15
Properties of the product being ground.....	15
Fill volume.....	15
General	16
Cleaning	16
Functional inspections	17
Replacing the breaker jaws	17
Copyright	18
Modifications	18
Safety instructions (table)	19

Safety

Target group: Anyone who deals with the machine in any capacity whatsoever.

The BB 200 is a modern, high-performance product manufactured by the Retsch GmbH, incorporating engineering representing the state of the art. It is entirely safe in operation, provided that the operator is familiar with the present technical manual and uses the machine for the purpose for which it was intended.

Safety note

You as the owner/operator must ensure that the persons entrusted with the use of the BB 200:

- * have read and understand all the regulations given in the section dealing with safety,
- * have made themselves familiar with all the operating instructions and rules for the particular target group, prior to commencing any work,
- * have complete, immediate and unrestricted access to the technical manuals for this machine.
- * New personnel shall have been familiarized with the safe and correct use of the BB 200, prior to beginning the work, by way of instruction given by a qualified person and/or on the basis of the present technical documentation.
- * Incorrect operation can result in personal injury and property damage. You are responsible for your own safety and for that of your employees.
- * Ensure that no unauthorized persons have access to the BB 200.

For your own protection, have your coworkers certify in writing the fact that they have received instruction in the operation of the BB 200. A suggestion for a printed form which can be used for this purpose will be found at the end of the chapter on safety.

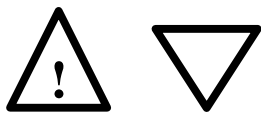

We reject herewith any and all claims in conjunction with personal injury or property damage resulting from failure to observe the following safety instructions.

Warnings

The following symbols are used to identify specific hazard potentials:



Personal injury

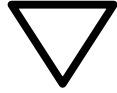

Property damage

Repairs

These operating instructions do not include any repair instructions. In the interest of your own safety, have repairs made only by the Retsch GmbH or an authorized representative (service technician).

In this case, please notify the following:

Local Retsch representative

Your supplier

The Retsch GmbH

Your address for service:

Confirmation

I have familiarized myself with the foreword to the operating instructions and the chapter on safety.

Owner/operator signature

Service technician's signature

Technical specifications

Machine designation: BB 200

Utilization in accordance with the intended purpose

NOTICE This device is not designed as a production machine and for continuous operation, but as a laboratory device, intended for single-shift intermittent periodic operation of 8 hours per day.

The BB 200 is suitable for reducing medium-hard to very-hard substances as well as for brittle and tough materials.

The ultimate fineness can be as little as 2 mm and, depending on the material being processed, may be even less.

The following is a list of some of the materials which can be ground using the BB 200:

Bakelite // bauxite // concrete // dolomite // ores // feldspar // granite // graywacke // glass // limestone // gravel // coal // coke // corundum // quartz // salts // refractory clay // slag // silicates // silicon // sintered materials // cement clinker, etc.



Do not make any modifications to the machine and use only RETSCH approved spares and accessories.

Failure to comply will invalidate the CE declaration and guarantee.

Gap width adjustment range

From 0 to about 30 mm using a threaded spindle

Throughput rate and ultimate fineness

The performance data, through-put rate and attainable ultimate fineness are dependent on the fracturing properties and the hardness of the product being ground. These values can only be determined empirically.

Receiver drawer volume

approx. 5 dm³

Electrical protection class

IP54

Mains connection

200 V, 50 Hz

230 V, 50 Hz

400 V, 50 Hz

200 V, 60 Hz

220 V, 60 Hz

Rated power

2000 VA, 1~, 3~

Pre-fuse

16 A

Electromagnetic Compatibility (EMC)

EMC class in accordance with DIN EN 55011: A

Noise emissions

Noise measurements according to DIN 45635-31-01-KL3

Characteristic noise values are dependent on the fracturing properties of the product being ground.

Examples:

Workplace-related emission value $L_{pAeq} = 84 \text{ dB(A)}$

Operating conditions:

Sample material: marble, grain size 40 - 80 mm

Adjusted gap width: < 1 mm

Final grain size: < 5 mm

Filling ratio of grinding chamber: approx. 65 %

or

Sound power level $L_{WA} = 101 \text{ dB(A)}$

Workplace-related emission value $L_{pAeq} = 92 \text{ dB(A)}$

Operating conditions:

Sample material: marble, grain size 40 - 80 mm

Adjusted gap width: < 1 mm

Final grain size: < 5 mm

Filling ratio of grinding chamber: approx. 65 %



Damage to hearing

The level of noise can be high depending on the type of material the duration of the grinding process.

- Noise that is excessive in terms of level and duration can cause impaired or permanently damaged hearing.
- **Ensure suitable sound-proofing measures or wear hearing protection.**

Equipment dimensions (approximate)

Height:	1160 mm	Width:	450 mm
Depth:	900 mm	Weight:	300 kg net

Footprint

450 mm x 900 mm; no safety clearances required!

Shipping and installation

Packing

The type of packaging used has been selected in accordance with the shipping mode. It complies with generally accepted packaging guidelines.

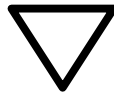

Please retain the packaging for the duration of the guarantee since, in case of a claim, returning in unsuitable packaging can jeopardize your guarantee entitlements.

Shipping

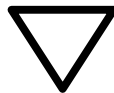

The BB 200 shall not be subjected to impact or vibration during transportation; it shall not be thrown. The electronic and mechanical components could otherwise be damaged.

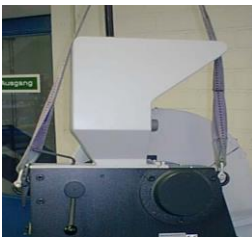

Fig.1

In order to be able to transport the BB 200 with a crane (capable of lifting at least 500 kg), it should be fixed with ties as in figure 1.

Intermediate storage

Please pay attention to the fact that the BB 200 must also be kept dry when in intermediate storage.

Temperature fluctuations



In case of wide temperature fluctuations (during shipment by air, for instance) the BB 200 will have to be protected against condensation; the electronic components could otherwise be damaged.

Intermediate storage

Also ensure that the BB 200 is stored in a dry place.

Requirements for the installation site

Ambient temperature:

5°C to 40°C



When the ambient temperature exceeds or falls below that specified, the electronic and mechanical components may be damaged, and performance data changed to an unknown extent.

Humidity:

Maximum relative humidity 80% at temperatures up to 31°C; linear decline down to 50% relative humidity at 40°C.



At higher humidity, the electronic and mechanical components may be damaged, and performance data changed to an unknown extent.

Installation site – altitude
max. 2000 m above mean sea level

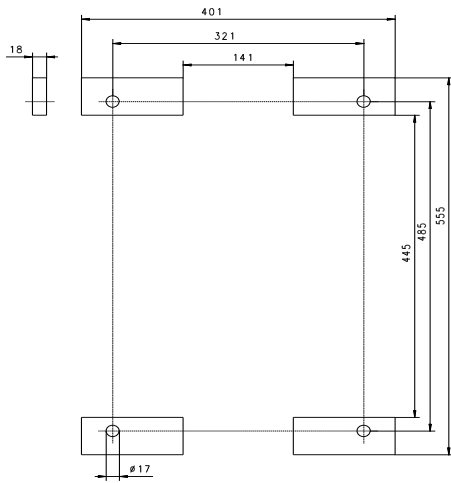

Fig. 2

Installation

Set up the BB 200 only on a flat and solid surface. Anchoring is not absolutely necessary since the vibrations transmitted to the environment by the free mass moments will be only barely perceptible. The machine may, if desired, be anchored using the holes in the feet as shown in **Fig.2**.

Electrical connection



WARNING When connecting the power cable to the mains supply, use an external fuse that complies with the regulations applicable to the place of installation.

- * Information about the required voltage and frequency of the device can be found on the type plate.
- * The listed values must agree with the existing mains supply.
- * The device may only be connected to the power supply using the connection cable supplied.
- * The circuit breaker at the installation site for connecting the mains cable to the mains should be suitable for higher inrush currents. It is recommended to use a type C circuit breaker or a Neozed or NH type fuse. The rated current of the fuse can be found on the rating plate or in the technical data.

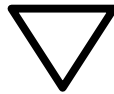

Failure to observe the values on the data plate can cause damage to either the electrical or the mechanical components or both.

Operation

Target group: Operators

Control elements and their use

Schematic view of the operating controls , part 1:

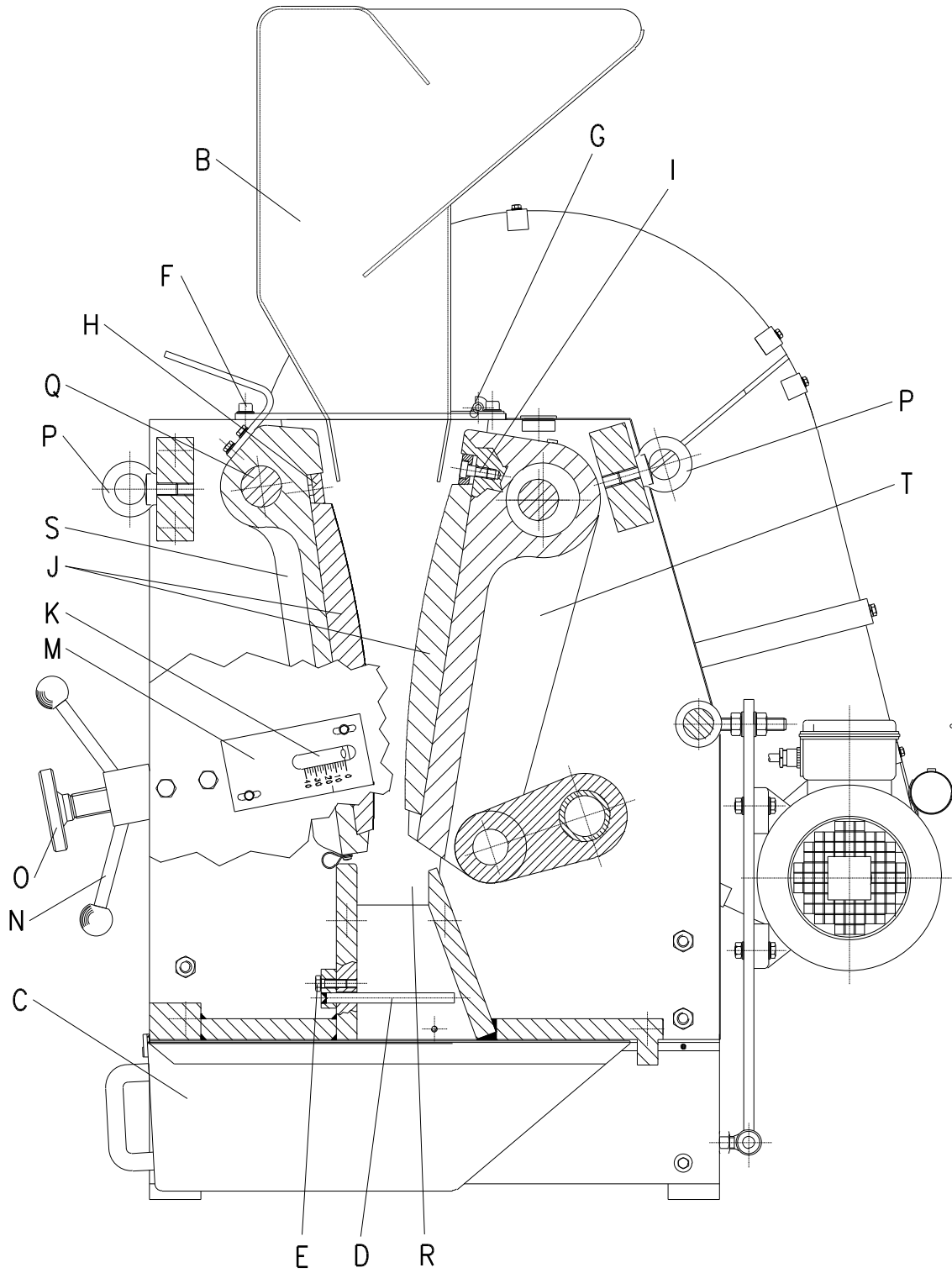

Side view

Control elements and their use

Schematic view of the operating controls, part 2:

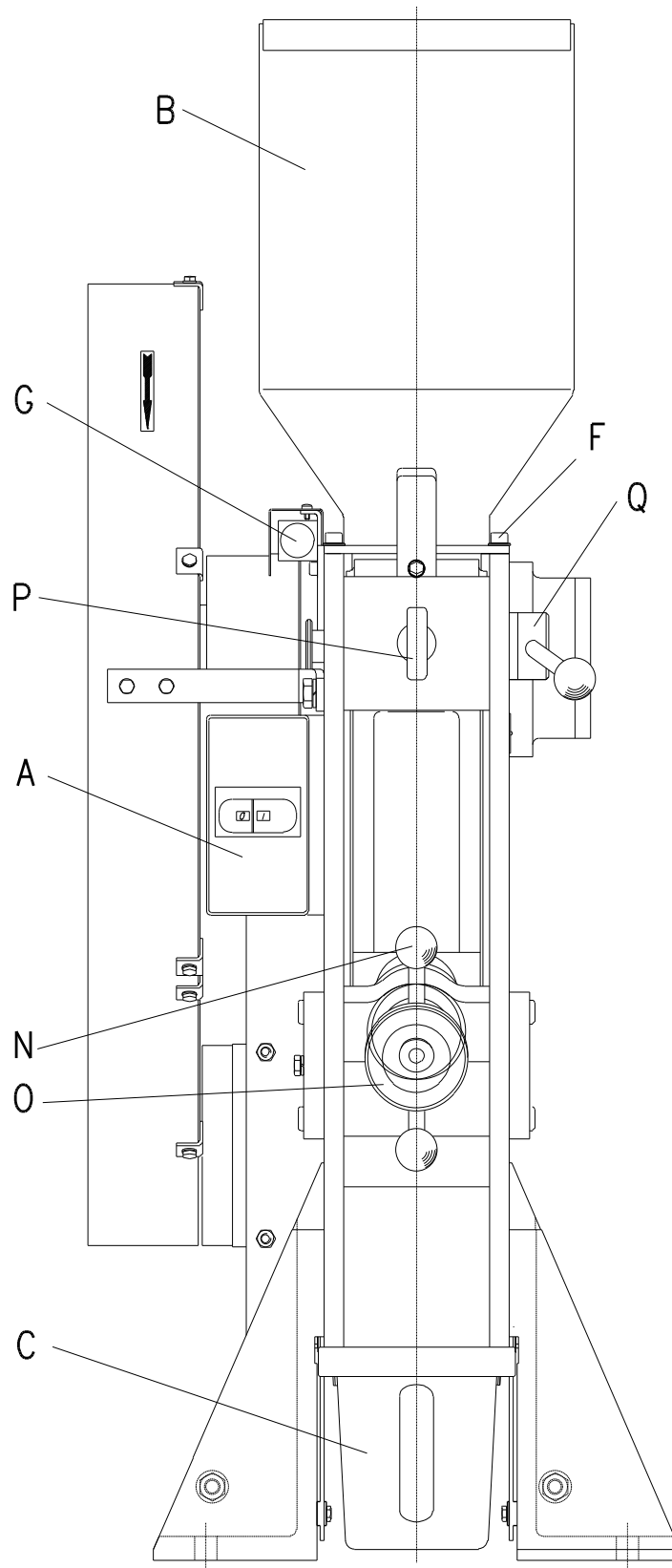

Front view

The operating controls and their functions
Summary table

Element	Description	Function
A	ON/OFF switch and motor protection switch	Starts and stops the jaw crusher drive; isolates the motor from the power supply in case of overloading
B	Fill hopper	Provides for the feed of material; prevents unintentionally reaching into the grinding chamber; prevents ejection of the material being processed
C	Receiver drawer $V = 5 \text{ dm}^3$	Accepts the ground sample material
D	Hand barrier	Prevents unintentionally reaching into the grinding chamber
E	Hex-head bolt	Affixes the hand barrier
F	Two machine screws	The fill hopper B can be swung to the rear once these screws have been removed.
G	Limit switch	Disables the drive (motor) when the fill hopper B is not in its normal operating position
H	Clamping shim	Secures the breaker jaws J on the breaker arms S and T .
I	Machine screw	Secure the clamping shim H
J	Breaker jaws	The size reduction components proper
K	Pointer	Indicates at scale M the width of the gap, at a tolerance of $\pm 1\text{mm}$
M	Scale	Indicates, in conjunction with the pointer K , the width of the gap; used to zero the gap width adjustment to accommodate for breaker jaw wear.
N	Lock nut	Locks the threaded spindle O
O	Threaded spindle	Increases the gap width when turned to the left, decreases when turned to the right
P	Screw eyes	Lifting points when using lifting tackle to move the device
Q	Pin	When the pointer K is removed and the fill hopper B swung to the rear, the pin can be pulled out and the breaker arm S removed.
R	Wearing plate	Prevents damage to the side panels
S	Breaker arm, stationary	The breaker jaw J is mounted here; the gap width can be modified by adjusting the threaded spindle O .
T	Breaker arm, moving	The breaker jaw J is mounted here; executes the grinding motion required for size reduction without manual effort

Starting the BB 200

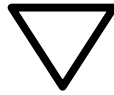

The BB 200 may be started only in the idling mode, *i.e.* without product in the hopper or grinding chamber. The presence of product before starting will cause the machine to block and can cause damage to mechanical components.

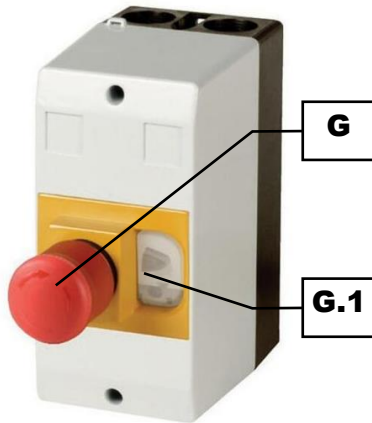

Fig. 3

In order to switch on the device, please proceed as follows:
The ON/OFF and motor protection switch is located on the left, at the front of the machine, at the left. **Fig.3**

- * Check whether the device is correctly connected to the power supply.
- * Release emergency stop switch (G) by turning it clockwise.
- * Start the device by pressing the adjacent ON-switch (G.1).
- * The device has been switched on and immediately starts with the grinding process.

The grinding operation can now be started, once the feed hopper is in place.

Stopping the BB 200

In order to switch off the device, please proceed as follows:
The ON/OFF and motor protection switch is located on the left, at the front of the machine **Fig.3**

- * Switch off the device by pressing the emergency stop switch (G) which is located on the front side of the device.
- * The switch engages. The device has been switched off. The motor is separated from the power supply and the movable breaker arm comes to a stop.

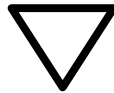

Stop the BB 200 only when all the grinding chamber has been cleared of product.
Mechanical components could be damaged by blockage.

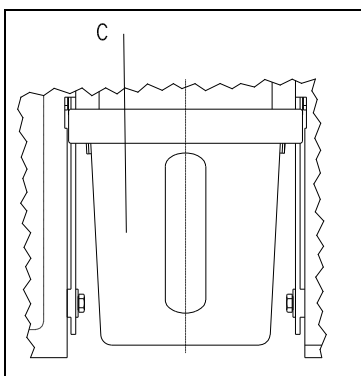

Fig. 4

Emptying the receiver drawer

Since the volume fed through the hopper can be greater than the capacity of the drawer ($V=5 \text{ dm}^3$), it will be necessary to empty the drawer **C** from time to time.

To achieve the maximum fill level in the drawer, it is necessary to shake it back and forth occasionally, without displacing the drawer by more than 30 mm.

Fig. 4

Dust extraction

Dust can be extracted externally via an industrial vacuum cleaner or an extractor as required. The nozzle for the dust extraction on the BB 200 has an external diameter of 38 mm (internal 36 mm).

⇒ Connect a suitable extraction tube (not supplied) to the nozzle of the dust extractor (**Fig. 5**).

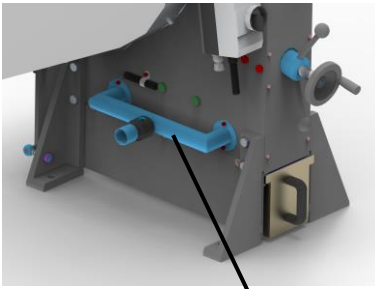

Fig. 5

1

Adjust the gap width

- * Start the BB 200 (idling, without product).
- * Loosen the lock nut **N** (turn to the left).
- * Turn the spindle **O** to the right to reduce the gap.
- * Turn the spindle **O** to the left to enlarge the gap.
- * The pointer **K** shows the approximate gap width at the scale **M**.
- * Re-tighten the lock nut **N** (turn to the right).

Fig. 6

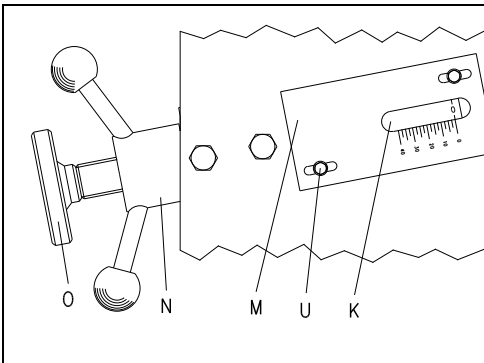

Fig. 6

Adjusting the zero setting for the gap width

- * Start the BB 200 (idling, without product).
- * Loosen the lock nut **N** (turn to the left).
- Carefully turn spindle **O** inwards (clockwise) until the two crusher arms just audibly meet.
- * Loosen the machine screws **U** (turn to the right).
- * Slide the **0** mark at the scale **M** to align with the tip of the pointer **K**.
- * Re-tighten the machine screws (turn to the right).

Fig. 6

Fill product to be ground

The fill hopper **B** can accept product up to grain sizes of 90 mm.

This hopper is not intended, however, to store a reserve of product; its function is exclusively to feed material to the grinding chamber and to keep ground product from being ejected.

Fig. 7

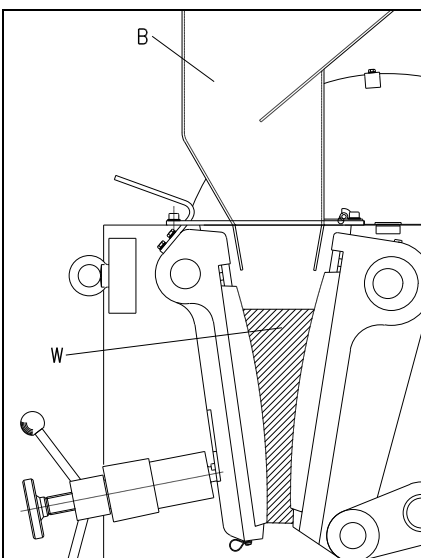

Fig. 7



If the grinding chamber **W** is filled more than 2/3 full, then the guide plates of the fill hopper could be damaged; the moving breaker arm would force the product into the crusher housing, behind the breaker arm.

Working instructions

Target group: Laboratory technicians

General

The BB 200 is a rugged, floor-mounted unit which is used primarily for preliminary grinding in preparation for final size reduction.

Its continuous operating concept also makes the BB 200 suitable for integration into fully automatic and semi-automatic processing lines.

The performance data, throughput rates and ultimate fineness which can be reached will depend on the breaking properties and hardness of the product and on the gap width which is selected.

Grain size of feedstock product

The maximum grain size is determined by the size of the fill hopper opening and in the BB 200 is a maximum of 90 mm.

Properties of the product being ground

Every hard and brittle product, exhibiting a hardness of greater than 3 on the Mohs scale, can as a rule be reduced with the BB 200.

Wet and oily product and that with a hardness index below 3 (Mohs scale) tend to be compressed and clump in the grinding chamber, this being due to the pressure exerted by the breaker jaws. It is for this reason that pre-grinding such material is hardly possible.

Fill volume

If the grinding chamber **W** is filled more than $2/3=800\text{ml}$ full, then the guide plates of the fill hopper could be damaged and the moving breaker would force the product into the crusher housing, behind the breaker arm. **Fig. 8**

The fill level will also influence the proportion of fine material in the product or specimen after preliminary grinding; the fuller the grinding chamber, the greater the share of fines.

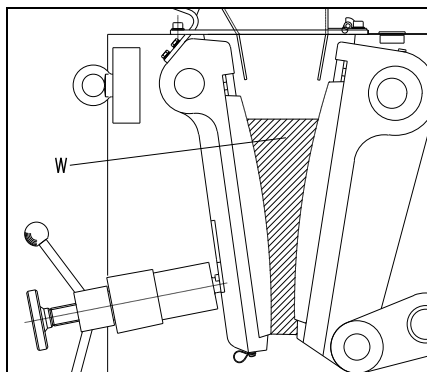

Fig. 8



If the grinding chamber **W** is filled more than $2/3=800\text{ml}$ full, then the fill hopper guide plates could be damaged; the moving breaker arm would force product into the crusher housing, behind the breaker arm.

General

Cleaning

An industrial vacuum cleaner and a stable, long-handled brush are best suited for cleaning the BB 200.

The stationary breaker arm **S** can also be removed to allow for sufficient cleaning of the grinding chamber. See **Fig. 9**

- * Unscrew the machine screws **F**.
- * Swing back the fill hopper **B**.
- * Grasp the breaker arm **S** at the grip and pull out the pin **Q**.
- * Lift out the breaker arm **S**.

The grinding chamber is now accessible.

Assemble in reverse order.

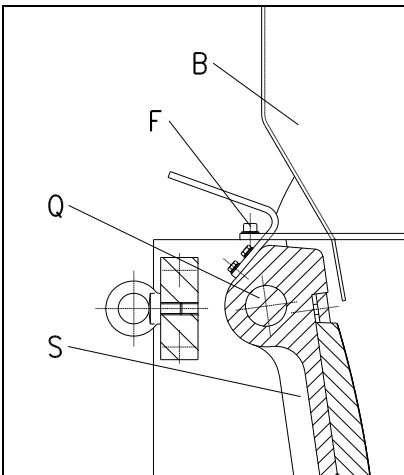

Fig. 9



The fill hopper may be swung back (by unscrewing the two machine screws) only by trained personnel and only for cleaning purposes. Operating the BB 200 without these machine screws in place and tightened down properly is absolutely prohibited.

Hazard of pinching fingers and hands!



Do not use running water to clean the BB 200.

Hazard of fatal electrical shock.

Using solvents is prohibited since the felt seals at the sides of the breaker arms could be damaged and/or grease packings could be washed out.

Functional inspections

The limit switch at the fill hopper is to be checked semiannually for proper functioning. **Fig. 10**

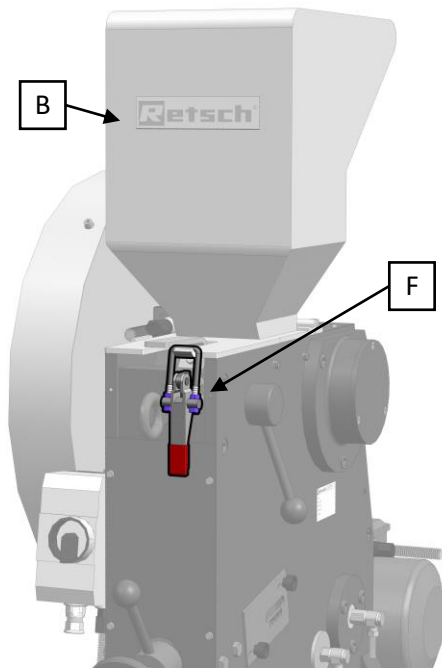

Fig. 10

- * Open the toggle clamp F on the filling hopper B.
- * Pull back the filling hopper.
- * The BB 200 stops completely.
- * Pull down and close the filling hopper B.

The BB 200 must not start up again.

- * Close the toggle clamp F on the filling hopper B.
- * Start the BB 200.

Replacing the breaker jaws

The stationary breaker arm S can be removed to provide sufficient space for dismantling the machine. **Fig. 11**

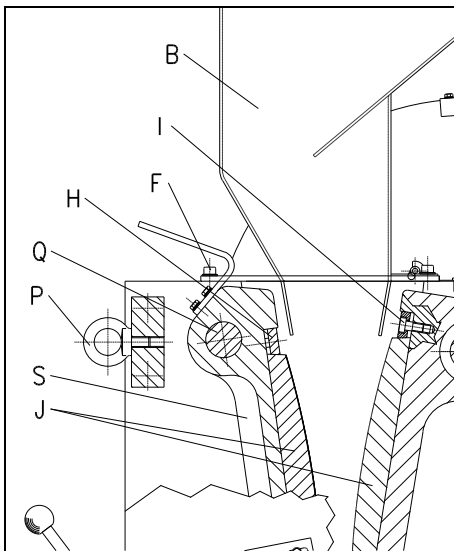

Fig. 11

- * Unscrew the machine screws F.
- * Swing back the fill hopper B.
- * Grasp the breaker arm S at the grip and pull out the pin Q.
- * Lift out the breaker arm S.
- * Unscrew the machine screws I.
- * Remove the clamping shims H.
- * Replace the breaker jaws J.
- * Assemble in reverse order.
- * Set the gap width as described in this instruction manual.



The fill hopper may be swung back (by unscrewing the two machine screws) only by trained personnel and only for cleaning purposes. Operating the BB 200 without these machine screws in place and tightened down properly is absolutely prohibited.

Hazard of pinching fingers and hands!

Copyright

Reproducing or distributing this documentation, utilizing or distributing the contents is permitted only with the express consent of Retsch GmbH.

Non-compliance will subject violators to claims for damages.

Modifications

Subject to modification without prior notice.

Safety instructions (table)

for the BB 200 taken from the chapters

Procedure	Action	Dangers
Safety	Not paying attention to the safety instructions can lead to damage to people and property.	Claims for damage are excluded in whatever form.
Packaging	Please retain the packaging for the duration of the guarantee period.	In the case of complaint your warranty rights can be endangered if the item is returned insufficiently packaged.
Transport	During transportation the BB 200 should not be knocked, shaken or thrown.	Electronic and mechanical components can become damaged.
Temperature variations	With severe variations in temperature, the BB 200 must be protected from condensation.	Electronic components can become damaged.
Scope of delivery	In the case of the delivery being incomplete and/or transport damage, you must inform the carrier and Retsch GmbH immediately (within 24 h).	Later complaints can under certain circumstances no longer be considered.
Environmental temperature	Drops below 5°C Rises above 40°C	Electronic and mechanical components can become damaged. Performance data change by an unknown extent.
Air humidity	Rises above 80% at temperatures up to 31%	Electronic and mechanical components can become damaged. Performance data change by an unknown extent.
Electrical connection	Mains supply does not match the values given on the type plate.	Electronic components can become damaged.
Operation	During starting, stopping and disconnection , there must be no material for grinding in the crushing chamber or in the feed hopper. The crushing chamber is not be filled by more than 2/3.	Mechanical components can possibly become damaged via a blockage. Otherwise the guide plates of the feed hopper can becoming damaged and the material for grinding will be delivered by the breaking arm into the crusher housing behind the arm.
Cleaning	Each time before cleaning, pull out the mains plug.	Danger of death by electrocution.
	Do not clean with running water.	Danger of death by electrocution.
	Solvents are not permitted.	Since they would damage the felt seals on the side of the breaking arms or wash out the grease filling.
	The filling hopper may be swung back for cleaning, by unscrewing the two socket screws, only by assigned, trained personnel. Operation of the BB 200 without screwed-in socket screws and without the filling hopper is not permitted.	Danger of crushing for fingers and hands.

JAW CRUSHER

BB 200 | 20.053.xxxx

EU DECLARATION OF CONFORMITY

We, represented by the undersigned, hereby declare that the above device complies with the following directives and harmonised standards:

Machinery Directive 2006/42/EC

Applied standards, in particular:

DIN EN ISO 12100 Machine Safety - General Design Principles

Electromagnetic compatibility 2014/30/EU (tested at 400 V, 50 Hz)

Applied standards, in particular:

EN 55011 Industrial, scientific and medical equipment - Radio-frequency disturbance characteristics - Limits and methods of measurement
DIN EN 61326-1 Electrical equipment for measurement, control and laboratory use - EMC requirements

Restriction of hazardous substances (RoHS) 2011/65/EU

Authorised person for compilation of the technical documentation:

Julia Kürten (Technical Documentation)

Furthermore, we declare that the relevant technical documentation for the above device has been prepared in accordance with Annex VII Part A of the Machinery Directive and we undertake to submit the documentation to the market surveillance authorities on request.

In the event of a modification of the device not agreed on by Retsch GmbH, as well as the use of non-approved spare parts or accessories, this declaration loses its validity.

Retsch GmbH

Haan, 09/2023



Dr. Stefan Mähler, Technical Manager





Copyright

© Copyright by
Retsch GmbH
Haan, Retsch-Allee 1-5
D-42781 Haan
Federal Republic of Germany